

**SECTION II**  
MATERIALS

2025

ASME Boiler and  
Pressure Vessel Code  
An International Code

**Part B**  
Nonferrous Material  
Specifications

Markings such as “ASME,” “ASME Standard,” or any other marking including “ASME,” ASME logos, or the ASME Single Certification Mark shall not be used on any item that is not constructed in accordance with all of the applicable requirements of the Code or Standard. Use of the ASME Single Certification Mark requires formal ASME certification; if no certification program is available, such ASME markings may not be used. (For Certification and Accreditation Programs, see <https://www.asme.org/certification-accreditation>.)

Items produced by parties not formally possessing an ASME Certificate may not be described, either explicitly or implicitly, as ASME certified or approved in any code forms or other document.

AN INTERNATIONAL CODE

# 2025 ASME Boiler & Pressure Vessel Code

2025 Edition

July 1, 2025

## II MATERIALS

### Part B

---

## Nonferrous Material Specifications

ASME Boiler and Pressure Vessel Committee  
on Materials



The American Society of  
Mechanical Engineers

Two Park Avenue • New York, NY • 10016 USA

Date of Issuance: July 1, 2025

This international code or standard was developed under procedures accredited as meeting the criteria for American National Standards and it is an American National Standard. The standards committee that approved the code or standard was balanced to ensure that individuals from competent and concerned interests had an opportunity to participate. The proposed code or standard was made available for public review and comment, which provided an opportunity for additional public input from industry, academia, regulatory agencies, and the public-at-large.

ASME does not “approve,” “certify,” “rate,” or “endorse” any item, construction, proprietary device, or activity. ASME does not take any position with respect to the validity of any patent rights asserted in connection with any items mentioned in this document, and does not undertake to insure anyone utilizing a standard against liability for infringement of any applicable letters patent, nor does ASME assume any such liability. Users of a code or standard are expressly advised that determination of the validity of any such patent rights, and the risk of infringement of such rights, is entirely their own responsibility.

Participation by federal agency representatives or persons affiliated with industry is not to be interpreted as government or industry endorsement of this code or standard.

ASME accepts responsibility for only those interpretations of this document issued in accordance with the established ASME procedures and policies, which precludes the issuance of interpretations by individuals.

The endnotes and preamble in this document (if any) are part of this American National Standard.



ASME Collective Membership Mark



ASME Single Certification Mark

The ASTM standards included within this ASME publication have been reproduced through a license agreement with ASTM International.

All rights reserved. “ASME” and the above ASME symbols are registered trademarks of The American Society of Mechanical Engineers. No part of this document may be copied, modified, distributed, published, displayed, or otherwise reproduced in any form or by any means, electronic, digital, or mechanical, now known or hereafter invented, without the express written permission of ASME. No works derived from this document or any content therein may be created without the express written permission of ASME. Using this document or any content therein to train, create, or improve any artificial intelligence and/or machine learning platform, system, application, model, or algorithm is strictly prohibited.

Library of Congress Catalog Card Number: 56-3934

Adopted by the Council of The American Society of Mechanical Engineers, 1914; latest edition 2025.

The American Society of Mechanical Engineers  
Two Park Avenue, New York, NY 10016-5990

Copyright © 2025 by  
THE AMERICAN SOCIETY OF MECHANICAL ENGINEERS  
All rights reserved  
Printed in U.S.A.

# TABLE OF CONTENTS

List of Sections .....	ix
Foreword .....	x
Statement of Policy on the Use of the ASME Single Certification Mark and Code Authorization in Advertising .....	xii
Statement of Policy on the Use of ASME Marking to Identify Manufactured Items .....	xii
Personnel .....	xiii
Correspondence With the Committee .....	xxxvi
Preface .....	xxxviii
Specifications Listed by Materials .....	xxxix
Specification Removal .....	xliv
Summary of Changes .....	xlv
Cross-Referencing in the ASME BPVC .....	xlvii
Statement of Policy on the Use of ASME Material Specifications .....	1
SB-26/SB-26M Specification for Aluminum-Alloy Sand Castings .....	3
SB-42 Specification for Seamless Copper Pipe, Standard Sizes .....	17
SB-43 Specification for Seamless Red Brass Pipe, Standard Sizes .....	25
SB-61 Specification for Steam or Valve Bronze Castings .....	33
SB-62 Specification for Composition Bronze or Ounce Metal Castings .....	37
SB-75/SB-75M Specification for Seamless Copper Tube .....	41
SB-96/SB-96M Specification for Copper-Silicon Alloy Plate, Sheet, Strip, and Rolled Bar for General Purposes and Pressure Vessels .....	51
SB-98/SB-98M Specification for Copper-Silicon Alloy Rod, Bar and Shapes .....	57
SB-108/SB-108M Specification for Aluminum-Alloy Permanent Mold Castings .....	63
SB-111/SB-111M Specification for Copper and Copper-Alloy Seamless Condenser Tubes and Ferrule Stock .....	81
SB-127 Specification for Nickel-Copper Alloy (UNS N04400) Plate, Sheet, and Strip .....	95
SB-135/SB-135M Specification for Seamless Brass Tube .....	105
SB-148 Specification for Aluminum-Bronze Sand Castings .....	115
SB-150/SB-150M Specification for Aluminum Bronze Rod, Bar, and Shapes .....	123
SB-151/SB-151M Specification for Copper-Nickel-Zinc Alloy (Nickel Silver) and Copper-Nickel Rod and Bar .....	131
SB-152/SB-152M Specification for Copper Sheet, Strip, Plate, and Rolled Bar .....	137
SB-160 Specification for Nickel Rod and Bar .....	145
SB-161 Specification for Nickel Seamless Pipe and Tube .....	155
SB-162 Specification for Nickel Plate, Sheet, and Strip .....	161
SB-163 Specification for Seamless Nickel and Nickel Alloy Condenser and Heat-Exchanger Tubes .....	177
SB-164 Specification for Nickel-Copper Alloy Rod, Bar, and Wire .....	191
SB-165 Specification for Nickel-Copper Alloy Seamless Pipe and Tube .....	205
SB-166 Specification for Nickel-Chromium-Aluminum Alloy, Nickel-Chromium-Iron Alloys, Nickel-Chromium-Cobalt-Molybdenum Alloy, Nickel-Iron- Chromium-Tungsten Alloy, and Nickel-Chromium-Molybdenum-Copper Alloy, Rod, Bar, and Wire .....	213
SB-167 Specification For Nickel-Chromium-Aluminum Alloys (UNS N06699), Nickel- Chromium-Iron Alloys (UNS N06600, N06601, N06603, N06690, N06693, N06025, N06045, and N06696), and Nickel-Chromium-Cobalt- Molybdenum Alloy (UNS N06617), Nickel-Iron-Chromium-Tungsten Alloy (UNS N06674), and Nickel-Chromium-Molybdenum-Copper Alloy (UNS N06235) Seamless Pipe and Tube .....	223

SB-168	Specification For Nickel-Chromium-Aluminum Alloys (UNS N06699), Nickel-Chromium-Iron Alloys (UNS N06600, N06601, N06603, N06690, N06693, N06025, N06045, and N06696), Nickel-Chromium-Cobalt-Molybdenum Alloy (UNS N06617), Nickel-Iron-Chromium-Tungsten Alloy (UNS N06674), and Nickel-Chromium-Molybdenum-Copper Alloy (UNS N06235) Plate, Sheet, and Strip	233
SB-169/SB-169M	Specification for Aluminum Bronze Sheet, Strip, and Rolled Bar	247
SB-171/SB-171M	Specification for Copper-Alloy Plate and Sheet for Pressure Vessels, Condensers, and Heat Exchangers	253
SB-187/SB-187M	Specification for Copper, Bus Bar, Rod, and Shapes and General Purpose Rod, Bar, and Shapes	261
SB-209/SB-209M	Specification for Aluminum and Aluminum-Alloy Sheet and Plate	271
SB-210	Specification for Aluminum and Aluminum-Alloy Drawn Seamless Tubes	315
SB-211/SB-211M	Specification for Aluminum and Aluminum-Alloy Rolled or Cold-Finished Bar, Rod, and Wire	327
SB-221	Specification for Aluminum and Aluminum-Alloy Extruded Bars, Rods, Wire, Profiles, and Tubes	341
SB-221M	Specification for Aluminum and Aluminum-Alloy Extruded Bars, Rods, Wire, Profiles, and Tubes (Metric)	359
SB-234	Specification for Aluminum and Aluminum-Alloy Drawn Seamless Tubes for Condensers and Heat Exchangers	379
SB-241/SB-241M	Specification for Aluminum and Aluminum-Alloy Seamless Pipe and Seamless Extruded Tube	387
SB-247	Specification for Aluminum and Aluminum-Alloy Die Forgings, Hand Forgings, and Rolled Ring Forgings	409
SB-248	Specification for General Requirements for Wrought Copper and Copper-Alloy Plate, Sheet, Strip, and Rolled Bar	427
SB-249/SB-249M	Specification for General Requirements for Wrought Copper and Copper-Alloy Rod, Bar, Shapes, and Forgings	441
SB-251/SB-251M	Specification for General Requirements for Wrought Seamless Copper and Copper-Alloy Tube	455
SB-265	Specification for Titanium and Titanium Alloy Strip, Sheet, and Plate	465
SB-271/SB-271M	Specification for Copper-Base Alloy Centrifugal Castings	479
SB-283/SB-283M	Specification for Copper and Copper-Alloy Die Forgings (Hot-Pressed)	487
SB-308/SB-308M	Specification for Aluminum-Alloy 6061-T6 Standard Structural Profiles	505
SB-315	Specification for Seamless Copper Alloy Pipe and Tube	511
SB-333	Specification for Nickel-Molybdenum Alloy Plate, Sheet, and Strip	523
SB-335	Specification for Nickel-Molybdenum Alloy Rod	527
SB-338	Specification for Seamless and Welded Titanium and Titanium Alloy Tubes for Condensers and Heat Exchangers	533
SB-348/SB-348M	Specification for Titanium and Titanium Alloy Bars and Billets	543
SB-359/SB-359M	Specification for Copper and Copper-Alloy Seamless Condenser and Heat Exchanger Tubes with Integral Fins	553
SB-363	Specification for Seamless and Welded Unalloyed Titanium and Titanium Alloy Welding Fittings	565
SB-366/SB-366M	Specification for Factory-Made Wrought Nickel and Nickel Alloy Fittings	571
SB-367	Specification for Titanium and Titanium Alloy Castings	581
SB-369	Specification for Copper-Nickel Alloy Castings	589
SB-381	Specification for Titanium and Titanium Alloy Forgings	595
SB-395/SB-395M	Specification for U-Bend Seamless Copper and Copper Alloy Heat Exchanger and Condenser Tubes	605
SB-407	Specification for Nickel-Iron-Chromium Alloy Seamless Pipe and Tube	619
SB-408	Specification for Nickel-Iron-Chromium Alloy Rod and Bar	625
SB-409	Specification for Nickel-Iron-Chromium Alloy Plate, Sheet, and Strip	631
SB-423	Specification for Nickel-Iron-Chromium-Molybdenum-Copper Alloy (UNS N08825 and N08221) Seamless Pipe and Tube	637

SB-424	Specification for Ni-Fe-Cr-Mo-Cu Alloy (UNS N08825, UNS N08221, and UNS N06845) Plate, Sheet, and Strip .....	643
SB-425	Specification for Ni-Fe-Cr-Mo-Cu Alloy (UNS N08825 and UNS N08221) Rod and Bar .....	649
SB-434	Specification for Nickel-Molybdenum-Chromium-Iron Alloys (UNS N10003, UNS N10242) Plate, Sheet, and Strip .....	657
SB-435	Specification for UNS N06002, UNS N06230, UNS N12160, and UNS R30556 Plate, Sheet, and Strip .....	661
SB-443	Specification for Nickel-Chromium-Molybdenum-Columbium Alloy (UNS N06625) and Nickel-Chromium-Molybdenum-Silicon Alloy (UNS N06219) Plate, Sheet, and Strip .....	665
SB-444	Specification for Nickel-Chromium-Molybdenum-Columbium Alloys (UNS N06625 and UNS N06852) and Nickel-Chromium-Molybdenum-Silicon Alloy (UNS N06219) Pipe and Tube .....	677
SB-446	Specification for Nickel-Chromium-Molybdenum-Columbium Alloy (UNS N06625), Nickel-Chromium-Molybdenum-Silicon Alloy (UNS N06219), and Nickel-Chromium-Molybdenum-Tungsten Alloy (UNS N06650) Rod and Bar .....	681
SB-462	Specification for Forged or Rolled Nickel Alloy Pipe Flanges, Forged Fittings, and Valves and Parts for Corrosive High-Temperature Service .....	687
SB-463	Specification for UNS N08020 Alloy Plate, Sheet, and Strip .....	693
SB-464	Specification for Welded UNS N08020, N08024, and N08026 Alloy Pipe ..	697
SB-466/SB-466M	Specification for Seamless Copper-Nickel Pipe and Tube .....	701
SB-467	Specification for Welded Copper-Nickel Pipe .....	709
SB-468	Specification for Welded UNS N08020, N08024, and N08026 Alloy Tubes .	719
SB-473	Specification for UNS N08020, UNS N08024, and UNS N08026 Nickel Alloy Bar and Wire .....	723
SB-493/SB-493M	Specification for Zirconium and Zirconium Alloy Forgings .....	733
SA-494/SA-494M	Specification for Castings, Nickel and Nickel Alloy .....	737
SB-505/SB-505M	Specification for Copper Alloy Continuous Castings .....	745
SB-511	Specification for Nickel-Iron-Chromium-Silicon Alloy Bars and Shapes ....	757
SB-514	Specification for Welded Nickel-Iron-Chromium Alloy Pipe .....	767
SB-515	Specification for Welded UNS N08120, UNS N08800, UNS N08810, and UNS N08811 Alloy Tubes .....	771
SB-516	Specification for Welded Nickel-Chromium-Aluminum Alloy (UNS N06699) and Nickel-Chromium-Iron Alloy (UNS N06600, UNS N06601, UNS N06603, UNS N06025, UNS N06045, UNS N06690, AND UNS N06693) Tubes .....	775
SB-517	Specification for Welded Nickel-Chromium-Iron Alloy (UNS N06600, UNS N06603, UNS N06025, and UNS N06045) Pipe .....	779
SB-523/SB-523M	Specification for Seamless and Welded Zirconium and Zirconium Alloy Tubes .....	783
SB-535	Specification for Nickel-Iron-Chromium-Silicon Alloys (UNS N08330 and N08332) Seamless Pipe and Tube .....	789
SB-536	Specification for Nickel-Iron-Chromium-Silicon Alloys (UNS N08330 and N08332) Plate, Sheet, and Strip .....	793
SB-543/SB-543M	Specification for Welded Copper and Copper-Alloy Heat Exchanger Tube .	805
SB-548	Test Method for Ultrasonic Inspection of Aluminum-Alloy Plate for Pressure Vessels .....	819
SB-550/SB-550M	Specification for Zirconium and Zirconium Alloy Bar and Wire .....	825
SB-551/SB-551M	Specification for Zirconium and Zirconium Alloy Strip, Sheet, and Plate ...	831
SB-564	Specification for Nickel Alloy Forgings .....	843
SB-572	Specification for UNS N06002, UNS N06230, UNS N12160, and UNS R30556 Rod .....	855
SB-573	Specification for Nickel-Molybdenum-Chromium-Iron Alloys (UNS N10003, N10242) Rod .....	861

SB-574	Specification for Low-Carbon Nickel-Chromium-Molybdenum, Low-Carbon Nickel-Molybdenum-Chromium, Low-Carbon Nickel-Molybdenum-Chromium-Tantalum, Low-Carbon Nickel-Chromium-Molybdenum-Copper, and Low-Carbon Nickel-Chromium-Molybdenum-Tungsten Alloy Rod .....	865
SB-575	Specification for Low-Carbon Nickel-Chromium-Molybdenum, Low-Carbon Nickel-Chromium-Molybdenum-Copper, Low-Carbon Nickel-Chromium-Molybdenum-Tantalum, Low-Carbon Nickel-Chromium-Molybdenum-Tungsten, and Low-Carbon Nickel-Molybdenum-Chromium Alloy Plate, Sheet, and Strip .....	871
SB-581	Specification for Nickel-Chromium-Iron-Molybdenum-Copper Alloy Rod ..	877
SB-582	Specification for Nickel-Chromium-Iron-Molybdenum-Copper Alloy Plate, Sheet, and Strip .....	883
SB-584	Specification for Copper Alloy Sand Castings for General Applications .....	887
SB-599	Specification for Nickel-Iron-Chromium-Molybdenum-Columbium Stabilized Alloy (UNS N08700) Plate, Sheet, and Strip .....	897
SB-619/SB-619M	Specification for Welded Nickel and Nickel-Cobalt Alloy Pipe .....	911
SB-620	Specification for Nickel-Iron-Chromium-Molybdenum Alloy (UNS N08320) Plate, Sheet, and Strip .....	919
SB-621	Specification for Nickel-Iron-Chromium-Molybdenum Alloy (UNS N08320) Rod .....	923
SB-622	Specification for Seamless Nickel and Nickel-Cobalt Alloy Pipe and Tube ..	927
SB-625	Specification for UNS N08925, UNS N08031, UNS N08034, UNS N08932, UNS N08926, UNS N08354, UNS N08830, and UNS R20033 Plate, Sheet, and Strip .....	935
SB-626	Specification for Welded Nickel and Nickel-Cobalt Alloy Tube .....	941
SB-637	Specification for Precipitation-Hardening and Cold Worked Nickel Alloy Bars, Forgings, and Forging Stock for Moderate or High-Temperature Service .....	947
SB-649	Specification for Ni-Fe-Cr-Mo-Cu-N Low-Carbon Alloys (UNS N08925, UNS N08031, UNS N08034, UNS N08354, and UNS N08926), and Cr-Ni-Fe-N Low-Carbon Alloy (UNS R20033) Bar and Wire, and Ni-Cr-Fe-Mo-N Alloy (UNS N08936) Wire .....	955
SB-653/SB-653M	Specification for Seamless and Welded Zirconium and Zirconium Alloy Welding Fittings .....	965
SB-658/SB-658M	Specification for Seamless and Welded Zirconium and Zirconium Alloy Pipe .....	969
SB-666/SB-666M	Practice for Identification Marking of Aluminum and Magnesium Products .....	975
SB-668	Specification for UNS N08028 Seamless Tubes .....	983
SB-672	Specification for Nickel-Iron-Chromium-Molybdenum-Columbium Stabilized Alloy (UNS N08700) Bar and Wire .....	987
SB-673	Specification for UNS N08925, UNS N08354, and UNS N08926 Welded Pipe .....	995
SB-674	Specification for UNS N08925, UNS N08354, and UNS N08926 Welded Tube .....	999
SB-675	Specification for UNS N08367 Welded Pipe .....	1003
SB-676	Standard Specification for UNS N08367 Welded Tube .....	1007
SB-677	Specification for Nickel-Iron-Chromium-Molybdenum and Iron-Nickel-Chromium-Molybdenum-Copper Seamless Pipe and Tube .....	1011
SB-688	Specification for Chromium-Nickel-Molybdenum-Iron (UNS N08366 and UNS N08367) Plate, Sheet, and Strip .....	1015
SB-690	Specification for Iron-Nickel-Chromium-Molybdenum Alloys (UNS N08366 and UNS N08367) Seamless Pipe and Tube .....	1025
SB-691	Specification for Iron-Nickel-Chromium-Molybdenum Alloys (UNS N08366 and UNS N08367) Rod, Bar, and Wire .....	1033
SB-704	Specification for Welded UNS N06625, UNS N06219, and UNS N08825 Alloy Tubes .....	1041
SB-705	Specification for Nickel-Alloy (UNS N06625, N06219 and N08825) Welded Pipe .....	1045
SB-706	Specification for Seamless Copper Alloy (UNS NO. C69100) Pipe and Tube .....	1049

SB-709	Specification for Iron-Nickel-Chromium-Molybdenum Alloy (UNS N08028) Plate, Sheet, and Strip	1057
SB-710	Specification for Nickel-Iron-Chromium-Silicon Alloy Welded Pipe	1063
SB-729	Specification for Seamless Nickel-Iron-Chromium-Molybdenum-Copper Nickel Alloy Pipe and Tube	1067
SB-751	Specification for General Requirements for Nickel and Nickel-Alloy Welded Tube	1071
SB-752/SB-752M	Specification for Castings, Zirconium-Base, Corrosion Resistant, for General Application	1079
SB-775	Specification for General Requirements for Nickel and Nickel-Alloy Welded Pipe	1085
SB-804	Specification for UNS N08367 and UNS N08926 Welded Pipe	1091
SB-815	Specification for Cobalt-Chromium-Nickel-Molybdenum-Tungsten Alloy (UNS R31233) Rod	1099
SB-818	Specification for Cobalt-Chromium-Nickel-Molybdenum-Tungsten Alloy (UNS R31233) Plate, Sheet, and Strip	1103
SB-824	Specification for General Requirements for Copper Alloy Castings	1107
SB-829	Specification for General Requirements for Nickel and Nickel Alloys Seamless Pipe and Tube	1115
SB-834	Specification for Pressure Consolidated Powder Metallurgy Iron-Nickel-Chromium-Molybdenum (UNS N08367), Nickel-Chromium-Molybdenum-Columbium (Nb) (UNS N06625), Nickel-Chromium-Iron Alloys (UNS N06600 and N06690), and Nickel-Chromium-Iron-Columbium-Molybdenum (UNS N07718) Alloy Pipe Flanges, Fittings, Valves, and Parts	1123
SB-861	Specification for Titanium and Titanium Alloy Seamless Pipe	1129
SB-862	Specification for Titanium and Titanium Alloy Welded Pipe	1139
SB-906	Specification for General Requirements for Flat-Rolled Nickel and Nickel Alloys Plate, Sheet, and Strip	1151
SB-928/SB-928M	Specification for High Magnesium Aluminum-Alloy Sheet and Plate for Marine Service and Similar Environments	1169
SB-956	Specification for Welded Copper and Copper-Alloy Condenser and Heat Exchanger Tubes with Integral Fins	1183
SF-467	Specification for Nonferrous Nuts for General Use	1195
SF-467M	Specification for Nonferrous Nuts for General Use [Metric]	1205
SF-468	Specification for Nonferrous Bolts, Hex Cap Screws, Socket Head Cap Screws, and Studs for General Use	1215
SF-468M	Specification for Nonferrous Bolts, Hex Cap Screws, and Studs for General Use [Metric]	1231
SB/EN 1706	Aluminum and Aluminum Alloys — Castings — Chemical Composition and Mechanical Properties	1243
<b>Mandatory Appendix I</b>	<b>Standard Units for Use in Equations</b>	1245
<b>Mandatory Appendix II</b>	<b>ASME Material Specifications</b>	1246
II-100	General	1246
II-200	Source Standards	1246
II-300	Permissibility of Superseded Editions for ASME Construction	1246
II-400	Structure of ASME Material Specifications	1246
<b>Mandatory Appendix III</b>	<b>Guidelines on Multiple Marking of Materials</b>	1255
III-100	Background	1255
III-200	Guidelines	1255
<b>Mandatory Appendix IV</b>	<b>Guidelines on the Approval of New Materials Under the ASME Boiler and Pressure Vessel Code</b>	1257
IV-100	Code Policy	1257
IV-200	Application	1257
IV-300	Chemical Composition	1259

IV-400	Metallurgical Structure and Heat Treatment .....	1259
IV-500	Mechanical Properties .....	1259
IV-600	Definitions for Data Collection Purposes .....	1259
IV-700	Required Sampling .....	1260
IV-800	Time-Independent Properties .....	1260
IV-900	Time-Dependent Properties .....	1260
IV-1000	Low-Temperature Properties .....	1262
IV-1100	Toughness Data .....	1262
IV-1200	Stress-Strain Curves .....	1262
IV-1300	Fatigue Data .....	1263
IV-1400	Physical Properties .....	1263
IV-1500	Data Requirements for Welds, Weldments, and Weldability .....	1263
IV-1600	Long-Term Properties Stability .....	1265
IV-1700	Requests for Additional Data .....	1265
IV-1800	New Materials Checklist .....	1265
IV-1900	Requirements for Recognized National or International Specifications .....	1266
IV-2000	Publication of Recognized National or International Specifications .....	1266
IV-2100	CEN Specifications .....	1266
<b>Nonmandatory Appendix A</b>	<b>Sources of Standards .....</b>	<b>1267</b>

**FIGURES**

II-400-1	Illustrative Table of ASME Material Specifications (for II-400 Explanation Purposes Only) .....	1254
----------	---	------

**TABLES**

I-1	Standard Units for Use in Equations .....	1245
II-200-1	Nonferrous Material Specifications Acceptable for BPVC Construction (Including Acceptable ASTM Editions) .....	1248
II-200-2	Nonferrous Material Specifications Acceptable for BPVC Construction .....	1254
IV-100-1	Hot Isostatically Pressed Component Requirements for Austenitic Stainless Steels, Austenitic- Ferritic (Duplex) Stainless Steels, Martensitic Stainless Steels, Ferritic Steels, and Nickel Alloys .....	1258
IV-800-1	ASTM Test Methods and Units for Reporting .....	1261
IV-1500-1	Example of a Comparison of Allowable Stresses of Base Metals With Compositions Similar to Those of Selected Welding Consumables and the Proposed New Base Metal .....	1264

# LIST OF SECTIONS

(25)

## SECTIONS

- I Rules for Construction of Power Boilers
  
- II Materials
  - Part A — Ferrous Material Specifications
  - Part B — Nonferrous Material Specifications
  - Part C — Specifications for Welding Rods, Electrodes, and Filler Metals
  - Part D — Properties (Customary)
  - Part D — Properties (Metric)
  
- III Rules for Construction of Nuclear Facility Components
  - Subsection NCA — General Requirements for Division 1 and Division 2
  - Appendices
  - Division 1
    - Subsection NB — Class 1 Components
    - Subsection NCD — Class 2 and Class 3 Components
    - Subsection NE — Class MC Components
    - Subsection NF — Supports
    - Subsection NG — Core Support Structures
  - Division 2 — Code for Concrete Containments
  - Division 3 — Containment Systems for Transportation and Storage of Spent Nuclear Fuel and High-Level Radioactive Material
  - Division 4 — Fusion Energy Devices
  - Division 5 — High Temperature Reactors
  
- IV Rules for Construction of Heating Boilers
  
- V Nondestructive Examination
  
- VI Recommended Rules for the Care and Operation of Heating Boilers
  
- VII Recommended Guidelines for the Care of Power Boilers
  
- VIII Rules for Construction of Pressure Vessels
  - Division 1
  - Division 2 — Alternative Rules
  - Division 3 — Alternative Rules for Construction of High Pressure Vessels
  
- IX Welding, Brazing, and Fusing Qualifications
  
- X Fiber Reinforced Plastic Pressure Vessels
  
- XI Rules for Inservice Inspection of Nuclear Reactor Facility Components
  - Division 1 — Rules for Inservice Inspection of Nuclear Power Plant Components
  - Division 2 — Requirements for Reliability and Integrity Management (RIM) Programs for Nuclear Reactor Facilities
  
- XII Rules for Construction and Continued Service of Transport Tanks
  
- XIII Rules for Overpressure Protection

## FOREWORD\*

(25)

In 1911, The American Society of Mechanical Engineers established the Boiler and Pressure Vessel Committee to formulate standard rules for the construction of steam boilers and other pressure vessels. In 2009, the Boiler and Pressure Vessel Committee was superseded by the following committees:

- (a) Committee on Power Boilers (I)
- (b) Committee on Materials (II)
- (c) Committee on Construction of Nuclear Facility Components (III)
- (d) Committee on Heating Boilers (IV)
- (e) Committee on Nondestructive Examination (V)
- (f) Committee on Pressure Vessels (VIII)
- (g) Committee on Welding, Brazing, and Fusing (IX)
- (h) Committee on Fiber-Reinforced Plastic Pressure Vessels (X)
- (i) Committee on Nuclear Inservice Inspection (XI)
- (j) Committee on Transport Tanks (XII)
- (k) Committee on Overpressure Protection (XIII)
- (l) Technical Oversight Management Committee (TOMC)

Where reference is made to “the Committee” in this Foreword, each of these committees is included individually and collectively.

The Committee’s function is to establish rules of safety relating to pressure integrity. The rules govern the construction\*\* of boilers, pressure vessels, transport tanks, and nuclear components, and the inservice inspection of nuclear components and transport tanks. For nuclear items other than pressure-retaining components, the Committee also establishes rules of safety related to structural integrity. The Committee also interprets these rules when questions arise regarding their intent. The technical consistency of the Sections of the Code and coordination of standards development activities of the Committees is supported and guided by the Technical Oversight Management Committee. The Code does not address other safety issues relating to the construction of boilers, pressure vessels, transport tanks, or nuclear components, or the inservice inspection of nuclear components or transport tanks. Users of the Code should refer to the pertinent codes, standards, laws, regulations, or other relevant documents for safety issues other than those relating to pressure integrity and, for nuclear items other than pressure-retaining components, structural integrity. Except for Sections XI and XII, and with a few other exceptions, the rules do not, of practical necessity, reflect the likelihood and consequences of deterioration in service related to specific service fluids or external operating environments. In formulating the rules, the Committee considers the needs of users, manufacturers, and inspectors of components addressed by the Code. The objective of the rules is to afford reasonably certain protection of life and property, and to provide a margin for deterioration in service to give a reasonably long, safe period of usefulness. Advancements in design and materials and evidence of experience have been recognized.

The Code contains mandatory requirements, specific prohibitions, and nonmandatory guidance for construction activities and inservice inspection and testing activities. The Code does not address all aspects of these activities and those aspects that are not specifically addressed should not be considered prohibited. The Code is not a handbook and cannot replace education, experience, and the use of engineering judgment. The phrase *engineering judgment* refers to technical judgments made by knowledgeable engineers experienced in the application of the Code. Engineering judgments must be consistent with Code philosophy, and such judgments must never be used to overrule mandatory requirements or specific prohibitions of the Code.

The Committee recognizes that tools and techniques used for design and analysis change as technology progresses and expects engineers to use good judgment in the application of these tools. The designer is responsible for complying with Code rules and demonstrating compliance with Code equations when such equations are mandatory. The Code

\* The information contained in this Foreword is not part of this American National Standard (ANS) and has not been processed in accordance with ANSI’s requirements for an ANS. Therefore, this Foreword may contain material that has not been subjected to public review or a consensus process. In addition, it does not contain requirements necessary for conformance to the Code.

\*\* *Construction*, as used in this Foreword, is an all-inclusive term comprising materials, design, fabrication, examination, inspection, testing, certification, and overpressure protection.

neither requires nor prohibits the use of computers for the design or analysis of components constructed to the requirements of the Code. However, designers and engineers using computer programs for design or analysis are cautioned that they are responsible for all technical assumptions inherent in the programs they use and the application of these programs to their design.

The rules established by the Committee are not to be interpreted as approving, recommending, or endorsing any proprietary or specific design, or as limiting in any way the manufacturer's freedom to choose any method of design or any form of construction that conforms to the Code rules.

The Committee meets regularly to consider revisions of the rules, new rules as dictated by technological development, Code cases, and requests for interpretations. Only the Committee has the authority to provide official interpretations of the Code. Requests for revisions, new rules, Code cases, or interpretations shall be addressed to the staff secretary in writing and shall give full particulars in order to receive consideration and action (see the Correspondence With the Committee page). Proposed revisions to the Code resulting from inquiries will be presented to the Committee for appropriate action. The action of the Committee becomes effective only after confirmation by ballot of the Committee and approval by ASME. Proposed revisions to the Code approved by the Committee are submitted to the American National Standards Institute (ANSI) and published at <http://go.asme.org/BPVCPublicReview> to invite comments from all interested persons. After public review and final approval by ASME, revisions are published at regular intervals in Editions of the Code.

The Committee does not rule on whether a component shall or shall not be constructed to the provisions of the Code. The scope of each Section has been established to identify the components and parameters considered by the Committee in formulating the Code rules.

Questions or issues regarding compliance of a specific component with the Code rules are to be directed to the ASME Certificate Holder (Manufacturer). Inquiries concerning the interpretation of the Code are to be directed to the Committee. ASME is to be notified should questions arise concerning improper use of the ASME Single Certification Mark.

When required by context in the Code, the singular shall be interpreted as the plural, and vice versa.

The words "shall," "should," and "may" are used in the Code as follows:

- *Shall* is used to denote a requirement.
- *Should* is used to denote a recommendation.
- *May* is used to denote permission, neither a requirement nor a recommendation.

# STATEMENT OF POLICY ON THE USE OF THE ASME SINGLE CERTIFICATION MARK AND CODE AUTHORIZATION IN ADVERTISING

ASME has established procedures to authorize qualified organizations to perform various activities in accordance with the requirements of the ASME Boiler and Pressure Vessel Code. It is the aim of the Society to provide recognition of organizations so authorized. An organization holding authorization to perform various activities in accordance with the requirements of the Code may state this capability in its advertising literature.

Organizations that are authorized to use the ASME Single Certification Mark for marking items or constructions that have been constructed and inspected in compliance with the ASME Boiler and Pressure Vessel Code are issued Certificates of Authorization. It is the aim of the Society to maintain the standing of the ASME Single Certification Mark for the benefit of the users, the enforcement jurisdictions, and the holders of the ASME Single Certification Mark who comply with all requirements.

Based on these objectives, the following policy has been established on the usage in advertising of facsimiles of the ASME Single Certification Mark, Certificates of Authorization, and reference to Code construction. The American Society of Mechanical Engineers does not “approve,” “certify,” “rate,” or “endorse” any item, construction, or activity and there shall be no statements or implications that might so indicate. An organization holding the ASME Single Certification Mark and/or a Certificate of Authorization may state in advertising literature that items, constructions, or activities “are built (produced or performed) or activities conducted in accordance with the requirements of the ASME Boiler and Pressure Vessel Code,” or “meet the requirements of the ASME Boiler and Pressure Vessel Code.” An ASME corporate logo shall not be used by any organization other than ASME.

The ASME Single Certification Mark shall be used only for stamping and nameplates as specifically provided in the Code. However, facsimiles may be used for the purpose of fostering the use of such construction. Such usage may be by an association or a society, or by a holder of the ASME Single Certification Mark who may also use the facsimile in advertising to show that clearly specified items will carry the ASME Single Certification Mark.

## STATEMENT OF POLICY ON THE USE OF ASME MARKING TO IDENTIFY MANUFACTURED ITEMS

The ASME Boiler and Pressure Vessel Code provides rules for the construction of boilers, pressure vessels, and nuclear components. This includes requirements for materials, design, fabrication, examination, inspection, and stamping. Items constructed in accordance with all of the applicable rules of the Code are identified with the ASME Single Certification Mark described in the governing Section of the Code.

Markings such as “ASME,” “ASME Standard,” or any other marking including “ASME” or the ASME Single Certification Mark shall not be used on any item that is not constructed in accordance with all of the applicable requirements of the Code.

Items shall not be described on ASME Data Report Forms nor on similar forms referring to ASME that tend to imply that all Code requirements have been met when, in fact, they have not been. Data Report Forms covering items not fully complying with ASME requirements should not refer to ASME or they should clearly identify all exceptions to the ASME requirements.

# PERSONNEL

## ASME Boiler and Pressure Vessel Standards Committees, Subgroups, and Working Groups

(25)

January 1, 2025

### TECHNICAL OVERSIGHT MANAGEMENT COMMITTEE (TOMC)

R. E. McLaughlin, <i>Chair</i>	M. D. Rana
N. A. Finney, <i>Vice Chair</i>	S. C. Roberts
S. J. Rossi, <i>Staff Secretary</i>	F. J. Schaaf, Jr.
R. W. Barnes	G. Scribner
T. L. Bedeaux	W. J. Sperko
C. T. Brown	D. Srnic
R. P. Deubler	R. W. Swayne
G. W. Galanes	J. Vattappilly
J. A. Hall	M. Wadkinson
T. E. Hansen	D. W. Lamond, <i>Ex-Officio Member</i>
G. W. Hembree	B. K. Nutter, <i>Ex-Officio Member</i>
R. B. Keating	E. M. Ortman, <i>Ex-Officio Member</i>
B. Linnemann	M. J. Pischke, <i>Ex-Officio Member</i>
W. M. Lundy	J. F. Henry, <i>Honorary Member</i>
D. I. Morris	

### Task Group on Remote Inspection and Examination (SI-TOMC)

S. C. Roberts, <i>Chair</i>	C. Stevens
M. Frediani, <i>Staff Secretary</i>	M. Tannenbaum
P. J. Coco	J. Cameron, <i>Alternate</i>
N. A. Finney	A. Byk, <i>Contributing Member</i>
S. A. Marks	S. J. Rossi, <i>Contributing Member</i>
R. Rockwood	C. A. Sanna, <i>Contributing Member</i>

### Special Working Group on High Temperature Technology (TOMC)

D. Dewees, <i>Chair</i>	B. F. Hantz
F. W. Brust	R. I. Jetter
T. D. Burchell	P. Smith
P. R. Donavin	

### Subgroup on Research and Development (TOMC)

S. C. Roberts, <i>Chair</i>	R. B. Keating
S. J. Rossi, <i>Staff Secretary</i>	R. E. McLaughlin
R. W. Barnes	E. M. Ortman
N. A. Finney	D. Andrei, <i>Contributing Member</i>
G. W. Galanes	

### Honors and Awards Committee (TOMC)

E. M. Ortman,	B. K. Nutter
G. W. Galanes	R. E. McLaughlin
D. W. Lamond	

### Subgroup on Strategic Initiatives (TOMC)

N. A. Finney, <i>Chair</i>	R. B. Keating
S. J. Rossi, <i>Staff Secretary</i>	R. E. McLaughlin
R. W. Barnes	E. M. Ortman
G. W. Galanes	S. C. Roberts
G. W. Hembree	M. Wadkinson

### ADMINISTRATIVE COMMITTEE

R. E. McLaughlin, <i>Chair</i>	B. K. Nutter
N. A. Finney, <i>Vice Chair</i>	E. M. Ortman
S. J. Rossi, <i>Staff Secretary</i>	M. J. Pischke
G. W. Galanes	M. D. Rana
R. B. Keating	S. C. Roberts
D. W. Lamond	R. R. Stevenson
B. Linnemann	M. Wadkinson

### Task Group on Field Sites (TOMC)

R. V. Wielgoszinski, <i>Chair</i>	J. Hoskinson
M. Vazquez, <i>Staff Secretary</i>	D. T. Peters
P. Becker	G. Scribner
T. Bedeaux	

### MARINE CONFERENCE GROUP

J. Oh, <i>Staff Secretary</i>	H. N. Patel
J. G. Hungerbuhler, Jr.	N. Prokopuk
G. Nair	J. D. Reynolds

**CONFERENCE COMMITTEE**

R. D. Troutt — Texas, *Chair*  
 J. T. Amato — Ohio, *Secretary*  
 M. O. Amuzie — New Jersey  
 R. Becker — Colorado  
 H. Berny — Minnesota  
 T. D. Boggs — Missouri  
 R. A. Boillard — Indiana  
 D. P. Brockerville —  
 Newfoundland and Labrador,  
 Canada  
 R. J. Bunte — Iowa  
 A. Buquis — Arizona  
 J. H. Burpee — Maine  
 M. Carlson — Washington  
 T. Carter — Mississippi  
 N. Chiasson — Prince Edward  
 Island, Canada  
 T. G. Clark — Oregon  
 B. J. Crawford — Georgia  
 E. L. Creaser — New Brunswick,  
 Canada  
 J. J. Dacanay — Hawaii  
 M. Davidian — California  
 R. DeLury — Manitoba, Canada  
 A. Denham — Michigan  
 C. Derks — Wisconsin  
 C. Dinic — Ontario, Canada  
 D. A. Ehler — Nova Scotia, Canada  
 S. D. Frazier — Washington  
 A. Gibbs — Wisconsin  
 T. J. Granneman II — Oklahoma  
 M. L. Jordan — Kentucky  
 R. Kamboj — British Columbia,  
 Canada

E. Kawa — Massachusetts  
 A. Khssassi — Quebec, Canada  
 D. Kinney — North Carolina  
 K. S. Lane — Alaska  
 A. M. Lorimor — South Dakota  
 T. Maher — Illinois  
 M. Mailman — Northwest  
 Territories, Canada  
 W. McGivney — City of New York,  
 New York  
 S. F. Noonan — Maryland  
 B. S. Oliver — New Hampshire  
 J. L. Oliver — Nevada  
 P. B. Polick — Illinois  
 B. Ricks — Montana  
 W. J. Ross — Pennsylvania  
 M. H. Sansone — New York  
 T. S. Seime — North Dakota  
 C. S. Selinger — Saskatchewan,  
 Canada  
 J. E. Sharier — Ohio  
 R. Spiker — North Carolina  
 D. Srnic — Alberta, Canada  
 D. J. Stenrose — Michigan  
 R. J. Stimson II — Kansas  
 R. K. Sturm — Utah  
 D. K. Sullivan — Arkansas  
 J. Taveras — Rhode Island  
 R. Termini — Louisiana  
 S. Van Slavens — Delaware  
 D. M. Warburton — Florida  
 E. Wiggins — Alabama

**INTERNATIONAL INTEREST REVIEW GROUP**

V. Felix  
 Y.-G. Kim  
 S. H. Leong  
 W. Lin  
 O. F. Manafa

C. Minu  
 Y.-W. Park  
 A. R. Reynaga Nogales  
 P. Williamson

**COMMITTEE ON POWER BOILERS (BPV I)**

E. M. Ortman, *Chair*  
 D. E. Tompkins, *Vice Chair*  
 U. D'Urso, *Staff Secretary*  
 D. I. Anderson  
 R. Antoniuk  
 J. L. Arnold  
 K. K. Coleman  
 S. Fincher  
 G. W. Galanes  
 P. F. Gilston  
 T. E. Hansen  
 J. S. Hunter  
 M. Ishikawa  
 M. Lemmons  
 M. Lewis  
 C. T. McDaris  
 R. E. McLaughlin  
 L. Moedinger  
 Y. Oishi  
 M. Ortolani

A. Spangenberg  
 D. E. Tuttle  
 J. Vattappilly  
 M. Wadkinson  
 F. Zeller  
 H. Michael, *Contributing Member*  
 D. Berger, *Honorary Member*  
 P. D. Edwards, *Honorary Member*  
 J. G. Feldstein, *Honorary Member*  
 D. N. French, *Honorary Member*  
 J. Hainsworth, *Honorary Member*  
 J. F. Henry, *Honorary Member*  
 P. A. Molvie, *Honorary Member*  
 J. T. Pillow, *Honorary Member*  
 B. W. Roberts, *Honorary Member*  
 J. M. Tanzosh, *Honorary Member*  
 R. V. Wielgoszinski, *Honorary  
 Member*  
 R. L. Williams, *Honorary Member*

**Executive Committee (BPV I)**

D. E. Tompkins, *Chair*  
 E. M. Ortman, *Vice Chair*  
 P. Becker  
 J. R. Braun  
 P. F. Gilston  
 A. Hantodkar

M. Lewis  
 C. T. McDaris  
 L. S. Nicol  
 A. Spangenberg  
 K. Thanupillai  
 M. Wadkinson

**Subgroup on Design (BPV I)**

C. T. McDaris, *Chair*  
 L. S. Tsai, *Secretary*  
 T. K. Acharya  
 D. I. Anderson  
 P. Becker  
 T. Huynh

L. Krupp  
 N. S. Ranck  
 J. Vattappilly  
 M. Wadkinson  
 C. Welles

**Subgroup on Fabrication and Examination (BPV I)**

P. F. Gilston, *Chair*  
 P. Becker, *Vice Chair*  
 J. L. Arnold  
 K. K. Coleman  
 S. Fincher  
 G. W. Galanes

T. E. Hansen  
 M. Lewis  
 S. J. Lombardo  
 C. T. McDaris  
 R. E. McLaughlin  
 Y. Oishi

**Subgroup on General Requirements and Piping (BPV I)**

D. E. Tompkins, *Chair*  
 M. Wadkinson, *Vice Chair*  
 M. Lemmons, *Secretary*  
 R. Antoniuk  
 T. E. Hansen  
 M. Ishikawa

S. J. Lombardo  
 R. E. McLaughlin  
 L. Moedinger  
 E. M. Ortman  
 D. E. Tuttle  
 J. Vattappilly

**Subgroup on Locomotive Boilers (BPV I)**

J. R. Braun, *Chair*  
 S. M. Butler, *Secretary*  
 G. W. Galanes  
 S. A. Lee

L. Moedinger  
 G. M. Ray  
 M. W. Westland

**Subgroup on Materials (BPV I)**

M. Lewis, *Chair*  
 L. S. Nicol, *Vice Chair*  
 S. H. Bowes  
 K. K. Coleman  
 G. W. Galanes  
 P. F. Gilston  
 K. Hayes  
 J. S. Hunter  
 E. Liebl

F. Masuyama  
 M. Ortolani  
 D. W. Rahoi  
 F. Zeller  
 B. W. Roberts, *Contributing  
 Member*  
 J. M. Tanzosh, *Contributing  
 Member*

**Subgroup on Solar Boilers (BPV I)**

R. E. Hearne, *Secretary*  
 S. Fincher

J. S. Hunter  
 P. Swarnkar

**Task Group on Additive Manufacturing (BPV I)**

K. K. Coleman, *Chair*  
 P. Becker, *Secretary*  
 J. L. Arnold  
 G. W. Galanes

P. F. Gilston  
 L. Moedinger  
 J. Vattappilly

**Task Group on Modernization (BPV I)**

S. J. Lombardo, <i>Chair</i>	G. W. Galanes
U. D'Urso, <i>Staff Secretary</i>	R. E. McLaughlin
D. I. Anderson	E. M. Ortman
J. L. Arnold	D. E. Tuttle

**European International Working Group (BPV I)**

A. Spangenberg, <i>Chair</i>	H. Michael
B. Daume	F. Miunske
J. Fleischfresser	M. Sykora
C. Jaekel	P. Chavdarov, <i>Contributing Member</i>
R. Kauer	J. Henrichsmeyer, <i>Contributing Member</i>
D. Koelbl	B. Müller, <i>Contributing Member</i>
S. Krebs	
T. Ludwig	
R. A. Meyers	

**India International Working Group (BPV I)**

K. Thanupillai, <i>Chair</i>	R. Madnani
A. Hantodkar, <i>Vice Chair</i>	S. Purkait
A. Ghosh, <i>Secretary</i>	A. Relekar
P. Brahma	M. Shiroya
H. Dalal	D. K. Shrivastava
T. Dhanraj	K. Singha
A. S. Ganesh	R. Sundararaj
S. Gopalakrishnan	S. Velu
A. Jain	S. Venkataramana

**COMMITTEE ON MATERIALS (BPV II)**

G. W. Galanes, <i>Chair</i>	F. Zeller
M. Ortolani, <i>Vice Chair</i>	J. Cameron, <i>Contributing Member</i>
C. E. Rodrigues, <i>Staff Secretary</i>	A. Chaudouet, <i>Contributing Member</i>
A. Appleton	K. K. Coleman, <i>Contributing Member</i>
P. Chavdarov	D. W. Gandy, <i>Contributing Member</i>
J. F. Grubb	K. L. Hayes, <i>Contributing Member</i>
J. A. Hall	W. Hoffelner, <i>Contributing Member</i>
D. O. Henry	K. E. Orie, <i>Contributing Member</i>
K. M. Hottle	D. T. Peters, <i>Contributing Member</i>
M. Ishikawa	B. W. Roberts, <i>Contributing Member</i>
M. Kowalczyk	J. M. Tanzosh, <i>Contributing Member</i>
D. L. Kurle	E. Uptis, <i>Contributing Member</i>
F. Masuyama	T. M. Cullen, <i>Honorary Member</i>
S. Neilsen	G. C. Hsu, <i>Honorary Member</i>
L. S. Nicol	
D. W. Rahoi	
W. Ren	
E. Shapiro	
R. C. Sutherlin	

**Executive Committee (BPV II)**

G. W. Galanes, <i>Chair</i>	K. L. Hayes
C. E. Rodrigues, <i>Staff Secretary</i>	K. M. Hottle
E. Alexis	W. MacDonald
A. Appleton	M. Ortolani
J. Cameron	P. K. Rai
P. Chavdarov	J. Robertson
J. F. Grubb	E. Shapiro
S. Guzey	

**Subgroup on External Pressure (BPV II)**

E. Alexis, <i>Chair</i>	J. F. Grubb
S. Guzey, <i>Vice Chair</i>	S. Krishnamurthy
J. A. A. Morrow, <i>Secretary</i>	D. L. Kurle
L. F. Campbell	R. W. Mikitka
H. Chen	P. K. Rai
M. Ghorashi	M. Wadkinson
D. S. Griffin	

**Subgroup on Ferrous Specifications (BPV II)**

K. M. Hottle, <i>Chair</i>	Y.-J. Kim
A. Appleton, <i>Vice Chair</i>	W. C. Mack
C. Hyde, <i>Secretary</i>	J. Nickel
D. Amire-Brahimi	D. Powelleit
G. Cuccio	R. Rezaeifar
O. Elkadim	F. Schmidt
D. Fialkowski	E. Uptis
J. Grimm	L. Watzke
J. F. Grubb	C. Meloy, <i>Contributing Member</i>
D. S. Janikowski	

**Subgroup on International Material Specifications (BPV II)**

P. Chavdarov, <i>Chair</i>	D. O. Henry
M. Ishikawa, <i>Vice Chair</i>	W. M. Lundy
C. Zhou, <i>Secretary</i>	F. Zeller
A. Chaudouet	T. F. Miskell, <i>Contributing Member</i>
H. Chen	E. Uptis, <i>Contributing Member</i>
A. F. Garbolevsky	

**Subgroup on Nonferrous Alloys (BPV II)**

J. Robertson, <i>Chair</i>	R. Rezaeifar
W. MacDonald, <i>Vice Chair</i>	E. Shapiro
R. M. Beldyk	J. Shubilla
J. M. Downs	R. C. Sutherlin
H. Dutta	R. Wright
J. F. Grubb	S. Yem
J. A. Hall	D. B. Denis, <i>Contributing Member</i>
D. Maitra	D. T. Peters, <i>Contributing Member</i>
D. W. Rahoi	

**Subgroup on Physical Properties (BPV II)**

P. K. Rai, <i>Chair</i>	P. K. Lam
S. Neilsen, <i>Vice Chair</i>	D. W. Rahoi
D. Chandiramani	E. Shapiro
H. Eshraghi	D. K. Verma
J. F. Grubb	S. Yem
B. F. Hantz	D. B. Denis, <i>Contributing Member</i>
R. D. Jones	

**Subgroup on Strength, Ferrous Alloys (BPV II)**

M. Ortolani, <i>Chair</i>	F. Masuyama
S. Rosinski, <i>Vice Chair</i>	M. Osterfoss
L. S. Nicol, <i>Secretary</i>	D. W. Rahoi
G. W. Galanes	M. Ueyama
J. A. Hall	F. Zeller
M. Ishikawa	F. Abe, <i>Contributing Member</i>
S. W. Knowles	

**Subgroup on Strength of Weldments (BPV II & BPV IX)**

K. L. Hayes, <i>Chair</i>	W. F. Newell, Jr.
G. W. Galanes, <i>Vice Chair</i>	J. A. Penso
S. H. Bowes, <i>Secretary</i>	D. W. Rahoi
K. K. Coleman, <i>Chair</i>	W. J. Sperko
M. Denault	J. P. Swezy, Jr.
D. W. Gandy	B. W. Roberts, <i>Contributing Member</i>
M. Ghahremani	

**China International Working Group (BPV II)**

Sanjiang Liu, <i>Chair</i>	C. Wang
H. Zhang, <i>Vice Chair</i>	Jinguang Wang
T. Xu, <i>Secretary</i>	Jiongxiang Wang
W. Cai	Q.-J. Wang
W. Fang	H.-C. Yang
F. Kong	J. Yang
H. Li	L. Yin
J. Li	X.-H. Zhang
Z. Rongcan	Y. Zhang
S. Tan	

**Working Group on Creep Strength Enhanced Ferritic Steels (BPV II)**

M. Ortolani, <i>Chair</i>	J. J. Sanchez-Hanton
G. W. Galanes, <i>Vice Chair</i>	J. A. Siefert
P. Becker, <i>Secretary</i>	W. J. Sperko
S. H. Bowes	F. Zeller
K. Kimura	F. Abe, <i>Contributing Member</i>
M. Lang	K. K. Coleman, <i>Contributing Member</i>
S. Luke	J. M. Tanzosh, <i>Contributing Member</i>
F. Masuyama	
T. Melfi	
W. F. Newell, Jr.	

**Working Group on Data Analysis and the Materials Properties Database (BPV II)**

W. MacDonald, <i>Chair</i>	D. Andrei, <i>Contributing Member</i>
C. E. Rodrigues, <i>Staff Secretary</i>	J. Cameron, <i>Contributing Member</i>
J. F. Grubb	G. W. Galanes, <i>Contributing Member</i>
F. Masuyama	W. C. Mack, <i>Contributing Member</i>
S. Neilsen	D. T. Peters, <i>Contributing Member</i>
M. Ortolani	W. Ren, <i>Contributing Member</i>
R. C. Sutherlin	E. Shapiro, <i>Contributing Member</i>
M. J. Swindeman	
F. Abe, <i>Contributing Member</i>	

**Task Group on Modernization of Materials Data (BPV II)**

C. E. Rodrigues, <i>Staff Secretary</i>	S. Neilsen
E. Alexis	L. S. Nicol
M. Brijlani	W. Ren
D. B. Denis	J. C. Sowinski
G. W. Galanes	M. Wadkinson
J. A. Hall	J. Cameron, <i>Contributing Member</i>
B. F. Hantz	J. F. Grubb, <i>Contributing Member</i>
A. Hassan	W. Hoffelner, <i>Contributing Member</i>
W. MacDonald	

**COMMITTEE ON CONSTRUCTION OF NUCLEAR FACILITY COMPONENTS (BPV III)**

R. B. Keating, <i>Chair</i>	K. Matsunaga
T. M. Adams, <i>Vice Chair</i>	B. McClone
D. E. Matthews, <i>Vice Chair</i>	S. McKillop
A. Maslowski, <i>Staff Secretary</i>	J. B. McLean
A. Appleton	J. C. Minichiello
S. Asada	M. N. Mitchell
R. W. Barnes	T. Nagata
W. H. Borter	J. B. Ossmann
M. E. Cohen	S. Pellet
R. P. Deubler	E. L. Pleins
P. R. Donavin	W. J. Sperko
A. C. Eberhardt	Y. J. Wang
J. V. Gardiner	W. Windes
W. J. Gerlinger	C. Basavaraju, <i>Alternate</i>
J. Grimm	T. P. Davis, <i>Contributing Member</i>
S. Hunter	T.-L. Sham, <i>Contributing Member</i>
R. I. Jetter	C. T. Smith, <i>Contributing Member</i>
J. I. Kim	R. M. Jesse, <i>Honorary Member</i>
G. H. Koo	E. B. Branch, <i>Honorary Member</i>
D. W. Lewis	M. N. Bressler, <i>Honorary Member</i>
M. A. Lockwood	G. D. Cooper, <i>Honorary Member</i>
D. W. Mann	D. F. Landers, <i>Honorary Member</i>
K. A. Manoly	C. Pieper, <i>Honorary Member</i>

**Executive Committee (BPV III)**

R. B. Keating, <i>Chair</i>	K. A. Manoly
A. Maslowski, <i>Secretary</i>	D. E. Matthews
T. M. Adams	B. McClone
T. P. Davis	S. McKillop
P. R. Donavin	J. B. McLean
D. W. Lewis	Yanli Wang
D. Mann	K. A. Kavanagh, <i>Alternate</i>

**Latin America International Working Group (BPV III)**

M. F. Liendo, <i>Chair</i>	A. J. Dall'Osto
J. Fernández, <i>Vice Chair</i>	J. I. Duo
O. Martinez, <i>Staff Secretary</i>	M. M. Gamizo
P. Yamamoto, <i>Secretary</i>	I. M. Guerreiro
E. H. Aldaz	I. A. Knorr
G. O. Anteri	D. E. Matthews
A. P. Antipasti	A. E. Pastor
D. O. Bordato	M. Rivero
G. Bourguigne	R. Taboada
M. Brusa	O. A. Verastegui
A. Claus	M. D. Vigliano
R. G. Cocco	M. Zunino

**China International Working Group (BPV III)**

Yong Wang, <i>Chair</i>	C. Peiyin
J. Gu, <i>Vice Chair</i>	Z. Sun
C. Jiang, <i>Vice Chair</i>	G. Tang
H. Yu, <i>Secretary</i>	L. Ting
L. Feng	J. Wen
L. Guo	F. Wu
D. Kang	C. Yang
Y. Li	P. Yang
H. Lin	W. Yang
Shenghua Liu	H. Yin
W. Liu	D. Yuangang
J. Ma	D. Zhao
K. Mao	Z. Zhong
D. E. Matthews	Q. Zhou
J. Ming	H. Zhu
W. Pei	

**Korea International Working Group (BPV III)**

G. H. Koo, <i>Chair</i>	B. Lee
O.-S. Kim, <i>Secretary</i>	D. Lee
H. Ahn	D. W. Lee
S. Cho	Sanghoon Lee
G.-S. Choi	Sungjae Lee
M. Choi	S.-G. Lee
M.-J. Choi	H. Lim
S. Choi	I.-K. Nam
J. Y. Hong	C.-K. Oh
N.-S. Huh	C.-Y. Oh
S. S. Hwang	E.-J. Oh
C. Jang	C. Park
I.-S. Jeong	H. Park
S. H. Kang	Y.-H. Park
J. Kim	Y. S. Pyun
J. I. Kim	J. H. Seo
J.-S. Kim	T. Shin
M.-W. Kim	S. Song
S.-S. Kim	T.-K. Song
Y.-B. Kim	W. J. Sperko
Y.-S. Kim	J. S. Yang
D. Kwon	O. Yoo

**European International Working Group (BPV III)**

J. Wendt, <i>Chair</i>	F. Juettemann
D. Koelbl, <i>Vice Chair</i>	M. H. Koeppen
R. Gersinska, <i>Secretary</i>	C. Kuschke
P. Ancion	H.-W. Lange
P. R. Donavin	T. Ludwig
R. Döring	M. Reichert
C. G. Frantescu	G. Roos
T. Hantzka	J. Rudolph
A. Huber	L. Sybertz
R. E. Hueggenberg	I. Tewes
E. Iacopetta	R. Tiete
A. Juengert	F. Wille

**Seismic Design Steering Committee (BPV III)**

T. M. Adams, <i>Chair</i>	R. M. Pace
K. Gresh, <i>Secretary</i>	M. Pérès
C. Basavaraju	K. Shibukuwa
D. Chowdhury	F. G. Abatt, <i>Contributing Member</i>
R. Döring	M. Arcaro, <i>Contributing Member</i>
G. H. Koo	P. R. Donavin, <i>Contributing Member</i>
A. Maekawa	
J. B. McLean	R. W. Haupt, <i>Contributing Member</i>

**Task Group on Alternate Requirements (BPV III)**

J. Wen, <i>Chair</i>	K. A. Manoly
R. R. Romano, <i>Secretary</i>	D. E. Matthews
T. Basso	S. McKillop
P. J. Coco	B. P. Nolan
P. R. Donavin	J. B. Ossmann
J. V. Gardiner	E. C. Renaud
F. Grant	M. A. Richter
J. Grimm	R. Summitt
R. S. Hill III	K. Voelsing
M. Kris	Yanli Wang
M. A. Lockwood	I. H. Tseng, <i>Alternate</i>

**India International Working Group (BPV III)**

S. B. Parkash, <i>Chair</i>	T. Mukherjee
V. Sehgal, <i>Vice Chair</i>	D. Narain
M. Brijlani, <i>Secretary</i>	A. D. Paranjpe
S. Aithal	J. R. Patel
A. D. Bagdare	E. L. Pleins
H. Dalal	S. Ponnappan
S. K. Goyal	T. J. P. Rao
D. Kulkarni	S. Singh
Raj Kumar	B. K. Sreedhar
Ritesh Kumar	N. Mistry, <i>Alternate</i>
S. Kumar	

**United Kingdom International Working Group (BPV III)**

P. M. James, <i>Chair</i>	S. A. Jones
J. Emslie, <i>Vice Chair</i>	B. McGlone
C. B. Carpenter, <i>Secretary</i>	B. Pellereau
T. Bann	E. I. S. Pendry
M. J. Chevalier	J. Randles
A. J. Cole-Baker	C. R. Schneider
M. Consonni	J. W. Stairmand
M. J. Crathorne	J. Sulley
P. Gill	J. Talamantes-Silva
G. Innes	A. J. Holt, <i>Contributing Member</i>

**Special Working Group on New Plant Construction Issues (BPV III)**

J. B. Ossmann, *Chair*  
 A. Maslowski, *Staff Secretary*  
 M. C. Buckley, *Secretary*  
 M. Arcaro  
 K. Burnett  
 A. Cardillo  
 P. J. Coco  
 K. Harris  
 E. Henry  
 J. Honcharik  
 M. Kris  
 R. E. McLaughlin  
 A. McLendon

Z. McLucas  
 N. J. McTiernan  
 K. Pigg  
 E. L. Pleins  
 J. Pollak  
 D. W. Sandusky  
 M. C. Scott  
 R. R. Stevenson  
 H. Xu  
 J. Yan  
 J. C. Minichiello, *Contributing Member*

**Special Working Group on Editing and Review (BPV III)**

D. E. Matthews, *Chair*  
 R. P. Deubler  
 A. C. Eberhardt  
 S. Hunter  
 B. McGlone

J. C. Minichiello  
 J. F. Strunk  
 Yanli Wang  
 C. Wilson

**Special Working Group on HDPE Stakeholders (BPV III)**

S. Patterson, *Secretary*  
 M. Kuntz

J. E. O'Sullivan

**Special Working Group on Honors and Awards (BPV III)**

R. W. Barnes, *Chair*  
 A. Appleton  
 R. M. Jessee

D. E. Matthews  
 J. C. Minichiello

**Special Working Group on International Meetings and IWG Liaisons (BPV III)**

D. E. Matthews, *Chair*  
 A. Maslowski, *Staff Secretary*  
 R. W. Barnes

P. R. Donavin  
 E. L. Pleins  
 W. J. Sperko

**Joint ACI-ASME Committee on Concrete Components for Nuclear Service (BPV III)**

J. B. McLean, *Chair*  
 L. J. Colarusso, *Vice Chair*  
 A. Dinizulu, *Staff Secretary*  
 S. Bae  
 C. J. Bang  
 A. C. Eberhardt  
 B. D. Hovis  
 T. C. Inman  
 C. Jones  
 T. Kang  
 N.-H. Lee  
 S. Malushte  
 J. A. Munshi  
 T. Muraki

J. S. Saini  
 J. F. Strunk  
 G. Thomas  
 A. Varma  
 S. Wang  
 A. Istar, *Alternate*  
 A. Adediran, *Contributing Member*  
 J.-B. Domage, *Contributing Member*  
 P. S. Ghosal, *Contributing Member*  
 M. R. Senecal, *Contributing Member*  
 Z. Shang, *Contributing Member*  
 M. Sircar, *Contributing Member*  
 C. T. Smith, *Contributing Member*

**Special Working Group on Modernization (SG Div 2) (BPV III)**

A. Varma, *Chair*  
 J. B. McLean, *Vice Chair*  
 J. S. Saini, *Vice Chair*  
 A. Adediran  
 S. Malushte

S. Wang  
 I. Zivanovic  
 R. Janowiak, *Contributing Member*  
 F. Lin, *Contributing Member*  
 J. A. Pires, *Contributing Member*

**Task Group on Steel-Concrete Composite Containments (SG Div 2) (BPV III)**

A. Varma, *Chair*  
 R. Janowiak  
 S. Malushte

J. B. McLean  
 J. A. Pires  
 J. S. Saini

**Working Group on Design (SG Div 2) (BPV III)**

N.-H. Lee, *Chair*  
 S. Bae  
 L. J. Colarusso  
 A. C. Eberhardt  
 B. D. Hovis  
 T. C. Inman  
 C. Jones  
 J. A. Munshi  
 T. Muraki  
 J. S. Saini  
 G. Thomas

S. Wang  
 A. Istar, *Alternate*  
 P. S. Ghosal, *Contributing Member*  
 S.-Y. Kim, *Contributing Member*  
 J. Kwon, *Contributing Member*  
 S. E. Ohler-Schmitz, *Contributing Member*  
 B. B. Scott, *Contributing Member*  
 Z. Shang, *Contributing Member*  
 M. Shin, *Contributing Member*  
 M. Sircar, *Contributing Member*

**Working Group on Materials, Fabrication, and Examination (SG Div 2) (BPV III)**

C. Jones, *Chair*  
 A. Eberhardt, *Vice Chair*  
 C. J. Bang  
 B. Birch  
 J.-B. Domage  
 T. Kang  
 N.-H. Lee

Z. Shang  
 J. F. Strunk  
 I. Zivanovic  
 A. A. Aboelmagd, *Contributing Member*  
 P. S. Ghosal, *Contributing Member*

**Subcommittee on Design (BPV III)**

P. R. Donavin, *Chair*  
 S. McKillop, *Vice Chair*  
 R. P. Deubler, *Secretary*  
 T. P. Davis  
 M. A. Gray  
 R. I. Jetter  
 R. B. Keating  
 J. I. Kim  
 K. A. Manoly  
 D. E. Matthews

M. N. Mitchell  
 B. Pellereau  
 Yanli Wang  
 W. F. Weitzel  
 C. Basavaraju, *Alternate*  
 G. L. Hollinger, *Contributing Member*  
 W. J. O'Donnell, Sr., *Contributing Member*  
 K. Wright, *Contributing Member*

**Subgroup on Component Design (SC-D) (BPV III)**

D. E. Matthews, <i>Chair</i>	J. C. Minichiello
P. Vock, <i>Vice Chair</i>	T. Mitsuhashi
D. Chowdhury, <i>Secretary</i>	D. Murphy
D. J. Ammerman	T. M. Musto
G. A. Antaki	T. Nagata
J. J. Arthur	S. Pellet
S. Asada	S. Willoughby-Braun
C. Basavaraju	C. Wilson
N. A. Costanzo	T. M. Adams, <i>Contributing Member</i>
R. P. Deubler	R. B. Keating, <i>Contributing Member</i>
P. Hirschberg	O.-S. Kim, <i>Contributing Member</i>
M. Kassir	R. J. Masterson, <i>Contributing Member</i>
D. Keck	H. S. Mehta, <i>Contributing Member</i>
T. R. Liszkai	G. Z. Tokarski, <i>Contributing Member</i>
K. A. Manoly	J. P. Tucker, <i>Contributing Member</i>
R. Martin	
K. R. May	

**Task Group on Pressurized Heavy Water Reactor (SG-CD) (BPV III)**

R. W. Barnes, <i>Chair</i>	E. L. Pleins
M. Brijlani	W. D. Reinhardt
D. E. Matthews	C. A. Sanna
B. McGlone	V. Sehgal
J. B. Ossmann	S. Singh
S. B. Parkash	

**Task Group to Improve Section III/XI Interface (SG-CD) (BPV III)**

P. Vock, <i>Chair</i>	C. A. Nove
E. Henry, <i>Secretary</i>	T. Nuoffer
G. A. Antaki	J. B. Ossmann
A. Cardillo	A. T. Roberts III
D. Chowdhury	J. Sciulli
J. Honcharik	A. Udyawar
J. Hurst	S. Willoughby-Braun
J. Lambin	

**Working Group on Core Support Structures (SG-CD) (BPV III)**

R. Martin, <i>Chair</i>	M. D. Snyder
R. Z. Ziegler, <i>Secretary</i>	R. O. Vollmer
G. W. Delpert	T. M. Wiger
L. C. Hartless	C. Wilson
D. Keck	Y. Wong
T. R. Liszkai	K. Hsu, <i>Alternate</i>
M. Nakajima	H. S. Mehta, <i>Contributing Member</i>

**Working Group on Design of Division 3 Containment Systems (SG-CD) (BPV III)**

D. J. Ammerman, <i>Chair</i>	D. Siromani
S. Klein, <i>Secretary</i>	C. R. Sydnor
J. Bignell	R. Sypulski
G. Bjorkman	R. Williamson
V. Broz	X. Zhai
D. D. Imholte	X. Zhang
D. W. Lewis	J. Smith, <i>Alternate</i>
A. Rigato	J. C. Minichiello, <i>Contributing Member</i>
P. Sakalaukus, Jr.	

**Working Group on HDPE Design of Components (SG-CD) (BPV III)**

M. Brandes	K. A. Manoly
J. R. Hebeisen	D. P. Munson
P. Krishnaswamy	R. Stakenborghs
M. Kuntz	B. Lin, <i>Alternate</i>

**Working Group on Piping (SG-CD) (BPV III)**

G. A. Antaki, <i>Chair</i>	W. F. Weitze
S. Weindorf, <i>Secretary</i>	K. Hsu, <i>Alternate</i>
C. Basavaraju	R. B. Keating, <i>Contributing Member</i>
J. Catalano	T. B. Littleton, <i>Contributing Member</i>
C. M. Faidy	Y. Liu, <i>Contributing Member</i>
R. G. Gilada	J. F. McCabe, <i>Contributing Member</i>
M. A. Gray	J. C. Minichiello, <i>Contributing Member</i>
R. J. Gurdal	A. N. Nguyen, <i>Contributing Member</i>
R. W. Haupt	M. S. Sills, <i>Contributing Member</i>
A. Hirano	N. C. Sutherland, <i>Contributing Member</i>
P. Hirschberg	G. Z. Tokarski, <i>Contributing Member</i>
M. Kassir	E. A. Wais, <i>Contributing Member</i>
D. Lieb	C.-I. Wu, <i>Contributing Member</i>
M. Moenssens	
I.-K. Nam	
K. E. Reid II	
B. Still	
D. Vlaicu	

**Working Group on Pressure Relief (SG-CD) (BPV III)**

K. R. May, <i>Chair</i>	B. J. Yonsky
J. F. Ball, <i>Vice Chair</i>	Y. Wong, <i>Alternate</i>
R. Krithivasan, <i>Secretary</i>	J. Yu, <i>Alternate</i>
J. W. Dickson	M. Brown, <i>Contributing Member</i>
N. Hansing	S. T. French, <i>Contributing Member</i>
S. Jones	S. Ruesenberg, <i>Contributing Member</i>
D. Miller	
T. Patel	

**Working Group on Pumps (SG-CD) (BPV III)**

D. Chowdhury, <i>Chair</i>	K. J. Noel
J. V. Gregg, Jr., <i>Secretary</i>	D. Skidmore
B. Busse	J. Sulley
R. Ibrahim	Y. Wong
T. Johnson	N. Chandran, <i>Alternate</i>

**Working Group on Supports (SG-CD) (BPV III)**

N. A. Costanzo, <i>Chair</i>	G. Z. Tokarski
U. S. Bandyopadhyay, <i>Secretary</i>	L. Vandersip
K. Avrithi	P. Wiseman
N. M. Bisceglia	J. Bozga, <i>Alternate</i>
R. P. Deubler	R. J. Masterson, <i>Contributing Member</i>
N. M. Graham	R. Roche-Rivera, <i>Contributing Member</i>
Y. Matsubara	J. R. Stinson, <i>Contributing Member</i>
S. Pellet	
G. Thomas	

**Working Group on Valves (SG-CD) (BPV III)**

P. Vock, <i>Chair</i>	C. A. Mizer
S. Jones, <i>Secretary</i>	H. O'Brien
M. C. Buckley	J. O'Callaghan
N. Hansing	M. Rain
G. A. Jolly	K. E. Reid II
J. Lambin	J. Sulley
T. Lippucci	Y. Wong, <i>Alternate</i>

**Working Group on Vessels (SG-CD) (BPV III)**

D. Murphy, <i>Chair</i>	M. C. Scott
S. Willoughby-Braun, <i>Secretary</i>	J. Shupert
J. J. Arthur	D. Vlaicu
C. Basavaraju	C. Wilson
M. Brijlani	R. Z. Ziegler
L. Constantinescu	M. R. Breach, <i>Alternate</i>
J. I. Kim	B. Basu, <i>Contributing Member</i>
D. E. Matthews	R. B. Keating, <i>Contributing Member</i>
T. Mitsuhashi	W. F. Weitze, <i>Contributing Member</i>
T. J. Schriefer	

**Subgroup on Design Methods (SC-D) (BPV III)**

S. McKillop, <i>Chair</i>	W. D. Reinhardt
P. R. Donavin, <i>Vice Chair</i>	P. Smith
J. Wen, <i>Secretary</i>	R. O. Vollmer
K. Avrithi	W. F. Weitze
M. A. Gray	Y. Wong, <i>Alternate</i>
J. V. Gregg, Jr.	S. R. Gosselin, <i>Contributing Member</i>
K. Hsu	H. T. Harrison III, <i>Contributing Member</i>
E. Isom	W. J. O'Donnell, Sr., <i>Contributing Member</i>
R. Kalnas	J. I. Kim
D. Keck	B. Pellereau
J. I. Kim	
B. Pellereau	K. Wright, <i>Contributing Member</i>

**Special Working Group on Computational Modeling for Explicit Dynamics (SG-DM) (BPV III)**

G. Bjorkman, <i>Chair</i>	P. Sakalaukus, Jr.
D. J. Ammerman, <i>Vice Chair</i>	D. Siromani
V. Broz, <i>Secretary</i>	C.-F. Tso
J. Bignell	M. C. Yaksh
S. Kuehner	U. Zencker
D. Molitoris	X. Zhang
W. D. Reinhardt	M. R. Breach, <i>Contributing Member</i>
E. Rosvall	Y. Wong, <i>Contributing Member</i>

**Working Group on Design Methodology (SG-DM) (BPV III)**

B. Pellereau, <i>Chair</i>	W. F. Weitze
R. O. Vollmer, <i>Secretary</i>	J. Wen
K. Avrithi	T. M. Wiger
C. Basavaraju	J. Wu
F. Berkepile	K. Hsu, <i>Alternate</i>
M. Cho	G. Banyay, <i>Contributing Member</i>
D. Clarkson	D. S. Bartran, <i>Contributing Member</i>
C. M. Faigy	R. D. Blevins, <i>Contributing Member</i>
Y.-J. Gao	M. R. Breach, <i>Contributing Member</i>
M. Kassir	H. T. Harrison III, <i>Contributing Member</i>
J. I. Kim	P. Hirschberg, <i>Contributing Member</i>
T. R. Liszkai	S. McKillop, <i>Contributing Member</i>
D. Lytle	A. Walker, <i>Contributing Member</i>
K. Matsunaga	K. Wright, <i>Contributing Member</i>
S. Ranganath	
W. D. Reinhardt	
S. Wang	

**Working Group on Environmental Fatigue Evaluation Methods (SG-DM) (BPV III)**

M. A. Gray, <i>Chair</i>	B. Pellereau
W. F. Weitze, <i>Secretary</i>	T. Seppanen
S. Asada	D. Vlaicu
K. Avrithi	K. Wang
R. C. Cipolla	K. A. Manoly, <i>Alternate</i>
T. M. Damiani	S. Cuvilliez, <i>Contributing Member</i>
C. M. Faigy	T. D. Gilman, <i>Contributing Member</i>
A. Hirano	S. R. Gosselin, <i>Contributing Member</i>
P. Hirschberg	Y. He, <i>Contributing Member</i>
K. Hsu	H. S. Mehta, <i>Contributing Member</i>
A. Morley	K. Wright, <i>Contributing Member</i>
J.-S. Park	

**Working Group on Fatigue Strength (SG-DM) (BPV III)**

P. R. Donavin, <i>Chair</i>	Y. Zou
T. M. Damiani	C. E. Hinnant, <i>Contributing Member</i>
D. W. DeJohn	P. Hirschberg, <i>Contributing Member</i>
C. M. Faigy	S. H. Kleinsmith, <i>Contributing Member</i>
P. Gill	S. Majumdar, <i>Contributing Member</i>
R. J. Gurdal	H. S. Mehta, <i>Contributing Member</i>
K. Hsu	W. J. O'Donnell, Sr., <i>Contributing Member</i>
J. I. Kim	S. Ranganath, <i>Contributing Member</i>
A. Morley	K. Wright, <i>Contributing Member</i>
B. Pellereau	
M. S. Shelton	
I. Viscarra	
Yanli Wang	
W. F. Weitze	

**Working Group on Probabilistic Methods in Design (SG-DM) (BPV III)**

M. Golliet, <i>Chair</i>	K. A. Manoly
R. Kalnas, <i>Vice Chair</i>	A. Morley
G. Brouette	B. Pellereau
R. Fougousse	A. Weaver
J. Hakii	M. Yagodich
E. Hanson	I. H. Tseng, <i>Alternate</i>
D. O. Henry	K. Avrithi, <i>Contributing Member</i>
A. Hirano	R. S. Hill III, <i>Contributing Member</i>

**Subgroup on Containment Systems for Spent Nuclear Fuel and High-Level Radioactive Material (BPV III)**

D. W. Lewis, *Chair*  
D. J. Ammerman, *Vice Chair*  
S. Klein, *Secretary*  
J. Bignell  
G. Bjorkman  
V. Broz  
D. D. Imholte  
A. Rigato  
P. Sakalaukus, Jr.  
D. Siromani

C. R. Sydnor  
R. Sypulski  
J. Wellwood  
X. J. Zhai  
X. Zhang  
J. Smith, *Alternate*  
W. H. Borter, *Contributing Member*  
E. L. Pleins, *Contributing Member*  
N. M. Simpson, *Contributing Member*

**Subgroup on Fusion Energy Devices (BPV III)**

T. P. Davis, *Chair*  
A. Maslowski, *Staff Secretary*  
M. Ellis, *Secretary*  
L. Babu  
M. Bashir  
J. P. Blanchard  
B. R. Doshi  
L. El-Guebaly  
R. Holmes  
D. Johnson

I. Kimihiro  
P. Mokaria  
F. J. Schaaf, Jr.  
P. Smith  
Y. Song  
D. White  
R. W. Barnes, *Contributing Member*  
W. K. Sowder, Jr., *Contributing Member*

**Special Working Group on Fusion Stakeholders (SG-FED) (BPV III)**

R. Holmes, *Chair*  
C. Barnes  
R. W. Barnes  
J. Brister  
A. A. Campbell  
V. Chugh  
T. P. Davis

S. S. Desai  
F. Deschamps  
M. Hua  
S. Krishnan  
W. K. Sowder, Jr.  
N. Young

**Working Group on General Requirements (SG-FED) (BPV III)**

P. Smith, *Chair*  
L. Babu  
T. P. Davis  
M. Ellis

B. McGlone  
P. Mokaria  
W. K. Sowder, Jr.  
D. White, *Contributing Member*

**Working Group on In-Vessel Components (SG-FED) (BPV III)**

M. Bashir, *Chair*  
T. P. Davis

S. T. Madabusi

**Working Group on Magnets (SG-FED) (BPV III)**

D. S. Barttan  
W. K. Sowder, Jr., *Contributing Member*

**Working Group on Materials (SG-FED) (BPV III)**

T. P. Davis

**Working Group on Vacuum Vessels (SG-FED) (BPV III)**

I. Kimihiro, *Chair*  
B. R. Doshi  
D. Johnson

**Subgroup on General Requirements (BPV III)**

B. McGlone, *Chair*  
A. McLendon, *Secretary*  
V. Apostolescu  
A. Appleton  
S. Bell  
G. Brouette  
P. J. Coco  
G. C. Deleanu  
N. DeSantis  
O. Elkadim  
J. V. Gardiner  
J. Grimm  
J. Harris  
J. W. Highlands  
E. V. Imbro  
K. A. Kavanagh  
Y.-S. Kim  
D. T. Meisch

L. Noyes  
E. C. Renaud  
T. N. Rezk  
J. Rogers  
B. S. Sandhu  
R. Spuhl  
J. L. Williams  
Y. Diaz-Castillo, *Alternate*  
J. DeKleine, *Contributing Member*  
S. F. Harrison, Jr., *Contributing Member*  
H. Michael, *Contributing Member*  
D. J. Roszman, *Contributing Member*  
C. T. Smith, *Contributing Member*  
G. E. Szabatura, *Contributing Member*

**Working Group on General Requirements for Graphite and Ceramic Composite Core Components and Assemblies (SG-GR) (BPV III)**

W. J. Geringer, *Chair*  
A. Appleton  
J. R. Berry  
A. A. Campbell  
C. Cruz  
Y. Diaz-Castillo  
J. Lang

M. N. Mitchell  
J. Potgieter  
E. C. Renaud  
S. Sekar  
R. Spuhl  
W. Windes  
B. Lin, *Alternate*

**Subgroup on High Temperature Reactors (BPV III)**

Yanli Wang, *Chair*  
N. Broom  
F. W. Brust  
M. E. Cohen  
W. J. Geringer  
B. F. Hantz  
M. Hiser  
R. I. Jetter  
K. Kimura  
G. H. Koo  
W. Li  
M. C. Messner

X. Wei  
W. Windes  
R. Wright  
G. L. Zeng  
J. Bass, *Alternate*  
P. Carter, *Contributing Member*  
W. O'Donnell, Sr., *Contributing Member*  
T.-L. Sham  
L. Shi, *Contributing Member*  
R. W. Swindeman, *Contributing Member*

**Special Working Group on High Temperature Reactor Stakeholders (SG-HTR) (BPV III)**

M. E. Cohen, *Chair*  
M. C. Albert  
M. Arcaro  
R. W. Barnes  
R. Bass  
N. Broom  
K. Burnett  
A. A. Campbell  
V. Chugh  
W. Corwin  
G. C. Deleanu  
R. A. Fleming  
K. Harris

R. I. Jetter  
G. H. Koo  
N. J. McTiernan  
M. N. Mitchell  
K. J. Noel  
J. Roll  
B. Song  
Yanli Wang  
X. Wei  
G. L. Zeng  
R. M. Iyengar, *Alternate*  
T. Asayama, *Contributing Member*

**Task Group on Alloy 709 Code Case (SG-HTR) (BPV III)**

Yanli Wang, <i>Chair</i>	W. J. Sperko
H. Mahajan, <i>Secretary</i>	R. Wright
R. I. Jetter	T.-L. Sham, <i>Contributing Member</i>
M. C. Messner	

**Working Group on Allowable Stress Criteria (SG-HTR) (BPV III)**

R. Wright, <i>Chair</i>	M. C. Messner
M. McMurtrey, <i>Secretary</i>	T. Patterson
R. W. Barnes	Yanli Wang
R. Bass	X. Wei
K. Kimura	R. M. Iyengar, <i>Alternate</i>
W. Li	R. W. Swindeman, <i>Contributing Member</i>
D. Maitra	
R. J. McReynolds	

**Task Group on Class A Rewrite (SG-HTR) (BPV III)**

Yanli Wang, <i>Chair</i>	N. J. McTiernan
R. W. Barnes	M. C. Messner
M. E. Cohen	T. Nguyen
R. I. Jetter	D. Pease
H. Mahajan	X. Wei
S. McKillop	J. Young

**Working Group on Analysis Methods (SG-HTR) (BPV III)**

M. C. Messner, <i>Chair</i>	X. Song
H. Mahajan, <i>Secretary</i>	Yanli Wang
R. Adibi-Asl	X. Wei
R. W. Barnes	S. X. Xu
J. A. Blanco	J. Young
P. Carter	J. Bass, <i>Alternate</i>
R. I. Jetter	M. R. Breach, <i>Contributing Member</i>
G. H. Koo	Y.-J. Gao, <i>Contributing Member</i>
T. Nguyen	T. Hassan, <i>Contributing Member</i>
M. Petkov	S. Krishnamurthy, <i>Contributing Member</i>
K. Pigg	M. J. Swindeman, <i>Contributing Member</i>
H. Qian	
T. Riordan	

**Task Group on Division 5 AM Components (SG-HTR) (BPV III)**

R. Wright, <i>Chair</i>	T. Patterson
R. W. Barnes	E. C. Renaud
F. W. Brust	D. Rudland
Z. Feng	B. Sutton
S. Lawler	I. J. Van Rooyen
X. Lou	Yanli Wang
M. McMurtrey	X. Wei
M. C. Messner	R. Bass, <i>Alternate</i>

**Working Group on Creep-Fatigue and Negligible Creep (SG-HTR) (BPV III)**

W. Li, <i>Chair</i>	M. McMurtrey
J. Bass	M. C. Messner
C. M. Brusconi	H. Qian
P. Carter	R. Rajasekaran
M. E. Cohen	M. Shah
J. I. Duo	Yanli Wang
R. I. Jetter	X. Wei
G. H. Koo	J. Young
H. Mahajan	R. Bass, <i>Alternate</i>

**Task Group on Graphite Design Analysis (SG-HTR) (BPV III)**

A. Mack, <i>Chair</i>	P.-A. Juan
J. Bass	J. Potgieter
S. Baylis	J. Quick
G. Beirnaert	M. Saitta
O. Booler	A. Walker

**Working Group on Nonmetallic Design and Materials (SG-HTR) (BPV III)**

W. Windes, <i>Chair</i>	J. Parks
W. J. Geringer, <i>Vice Chair</i>	K. Pigg
J. Potgieter, <i>Secretary</i>	J. Podhiny
G. Beirnaert	J. Roll
A. A. Campbell	A. Tzelepi
C. Chen	A. Walker
A. N. Chereskin	Yanli Wang
V. Chugh	G. L. Zeng
C. Contescu	J. Bass, <i>Alternate</i>
N. Gallego	A. Appleton, <i>Contributing Member</i>
S. T. Gonczy	R. W. Barnes, <i>Contributing Member</i>
K. Harris	S.-H. Chi, <i>Contributing Member</i>
M. G. Jenkins	Y. Katoh, <i>Contributing Member</i>
P.-A. Juan	J. B. Ossmann, <i>Contributing Member</i>
J. Lang	M. P. Metcalfe
A. Mack	M. N. Mitchell
M. P. Metcalfe	J. Quick, <i>Contributing Member</i>
M. N. Mitchell	M. Saitta, <i>Contributing Member</i>

**Task Group on High Temperature Piping Design (SG-HTR) (BPV-III)**

G. A. Antaki, <i>Chair</i>	H. Mahajan
S. Weindorf, <i>Secretary</i>	J. C. Minichiello
R. Adibi-Asl	D. Pease
T. D. Al-Shawaf	Yanli Wang
D. Bankston, Jr.	C. D. Weary
R. P. Deubler	T.-L. Sham, <i>Contributing Member</i>
R. I. Jetter	

**Subgroup on Materials, Fabrication, and Examination (BPV III)**

D. W. Mann, <i>Chair</i>	M. Kris
J. Grimm, <i>Vice Chair</i>	T. Melfi
J. B. Ossmann, <i>Vice Chair</i>	I.-K. Nam
S. Hunter, <i>Secretary</i>	J. E. O'Sullivan
W. H. Borter	M. C. Scott
M. Brijlani	W. J. Sperko
G. R. Cannell	J. F. Strunk
A. Cardillo	W. Windes
S. Cho	R. Wright
P. J. Coco	H. Xu
R. H. Davis	S. Yee
D. B. Denis	J. Wise, Jr., <i>Alternate</i>
B. D. Frew	S. Wolbert, Jr., <i>Alternate</i>
D. W. Gandy	R. W. Barnes, <i>Contributing Member</i>
S. E. Gingrich	S. Levitus, <i>Contributing Member</i>
M. Golliet	H. Michael, <i>Contributing Member</i>
L. S. Harbison	

**Working Group on Advanced Manufacturing (SG-MFE) (BPV III)**

D. W. Mann, <i>Chair</i>	E. C. Renaud
D. W. Gandy, <i>Secretary</i>	W. J. Sperko
D. Chowdhury	J. F. Strunk
P. J. Coco	J. Sulley
B. D. Frew	S. Tate
J. Grimm	J. Wise
J. Lambin	S. Wolbert
T. Lippucci	H. Xu
T. Melfi	R. H. Davis, <i>Alternate</i>
A. Mori	S. Malik, <i>Contributing Member</i>

**Joint Working Group on HDPE (SG-MFE) (BPV III)**

M. Brandes, <i>Chair</i>	K. Manoly
T. M. Musto, <i>Chair</i>	D. P. Munson
J. B. Ossmann, <i>Secretary</i>	J. O'Sullivan
G. Brouette	V. Rohatgi
M. C. Buckley	F. Schaaf, Jr.
S. Choi	S. Schuessler
M. Golliet	R. Stakenborghs
J. Hebeisen	M. Troughton
J. Johnston, Jr.	P. Vibien
P. Krishnaswamy	J. Wright
M. Kuntz	T. Adams, <i>Contributing Member</i>
B. Lin	

**COMMITTEE ON HEATING BOILERS (BPV IV)**

M. Wadkinson, <i>Chair</i>	J. A. Hall
J. L. Kleiss, <i>Vice Chair</i>	M. Mengon
C. R. Ramcharran, <i>Staff Secretary</i>	Y. Teng
B. Ahee	D. Picart, <i>Delegate</i>
L. Badziagowski	Y. R. Cho, <i>Alternate</i>
T. L. Bedeaux	B. J. Iske, <i>Alternate</i>
B. Calderon	T. Wagner, <i>Alternate</i>
J. P. Chicoine	H. Michael, <i>Contributing Member</i>
C. Dinic	P. A. Molvie, <i>Contributing Member</i>
J. M. Downs	

**Executive Committee (BPV IV)**

M. Wadkinson, <i>Chair</i>	J. P. Chicoine
C. R. Ramcharran, <i>Staff Secretary</i>	J. A. Hall
T. L. Bedeaux	J. L. Kleiss

**Subgroup on Cast Boilers (BPV IV)**

J. P. Chicoine, <i>Chair</i>	J. L. Kleiss
J. M. Downs, <i>Vice Chair</i>	M. Mengon
C. R. Ramcharran, <i>Staff Secretary</i>	B. J. Iske, <i>Alternate</i>
T. L. Bedeaux	T. Wagner, <i>Alternate</i>
J. A. Hall	

**Subgroup on Materials (BPV IV)**

J. A. Hall, <i>Chair</i>	T. L. Bedeaux
J. M. Downs, <i>Vice Chair</i>	Y. Teng
C. R. Ramcharran, <i>Staff Secretary</i>	M. Wadkinson
L. Badziagowski	

**Subgroup on Water Heaters (BPV IV)**

J. L. Kleiss, <i>Chair</i>	C. Dinic
L. Badziagowski, <i>Vice Chair</i>	M. Mengon
C. R. Ramcharran, <i>Staff Secretary</i>	Y. Teng
B. Ahee	B. J. Iske, <i>Alternate</i>
M. Carlson	T. Wagner, <i>Alternate</i>
J. P. Chicoine	P. A. Molvie, <i>Contributing Member</i>

**Subgroup on Welded Boilers (BPV IV)**

T. L. Bedeaux, <i>Chair</i>	J. L. Kleiss
J. P. Chicoine, <i>Vice Chair</i>	M. Mengon
C. R. Ramcharran, <i>Staff Secretary</i>	M. Wadkinson
B. Ahee	M. Washington
E. Alexis	B. J. Iske, <i>Alternate</i>
L. Badziagowski	M. J. Melita, <i>Alternate</i>
B. Calderon	T. J. Wagner, <i>Alternate</i>
M. Carlson	P. A. Molvie, <i>Contributing Member</i>
C. Dinic	

**COMMITTEE ON NONDESTRUCTIVE EXAMINATION (BPV V)**

N. A. Finney, <i>Chair</i>	P. Lang
C. May, <i>Vice Chair</i>	T. R. Lerohl
C. R. Ramcharran, <i>Staff Secretary</i>	J. Schoneweis
D. Bajula	P. B. Shaw
P. L. Brown	C. Vorwald
M. A. Burns	M. Carlson, <i>Alternate</i>
N. Carter	J. E. Batey, <i>Contributing Member</i>
C. Emslander	T. Clausing, <i>Contributing Member</i>
A. F. Garbolevsky	J. F. Halley, <i>Contributing Member</i>
P. T. Hayes	R. W. Kruzic, <i>Contributing Member</i>
G. W. Hembree	L. E. Mullins, <i>Contributing Member</i>
F. B. Kovacs	H. C. Graber, <i>Honorary Member</i>
K. Krueger	T. G. McCarty, <i>Honorary Member</i>
B. D. Laite	

**Executive Committee (BPV V)**

C. May, <i>Chair</i>	F. B. Kovacs
N. A. Finney, <i>Vice Chair</i>	K. Krueger
C. R. Ramcharran, <i>Staff Secretary</i>	B. D. Laite
V. F. Godinez-Azcuaga	E. Peloquin
P. T. Hayes	C. Vorwald
G. W. Hembree	

**Subgroup on General Requirements/Personnel Qualifications and Inquiries (BPV V)**

C. Vorwald, <i>Chair</i>	P. Lang
K. Krueger, <i>Vice Chair</i>	T. R. Lerohl
D. Bajula	C. May
N. Carter	J. Schoneweis
P. Chavdarov	T. Clausing, <i>Contributing Member</i>
C. Emslander	J. F. Halley, <i>Contributing Member</i>
N. A. Finney	D. I. Morris, <i>Contributing Member</i>
G. W. Hembree	J. P. Swezy, Jr., <i>Contributing Member</i>
F. B. Kovacs	

**Subgroup on Volumetric Methods (BPV V)**

C. May, <i>Chair</i>	K. Krueger
P. T. Hayes, <i>Vice Chair</i>	N. Pasemko
P. L. Brown	E. Peloquin
N. A. Finney	J. Schoneweis
A. F. Garbolevsky	C. Vorwald
V. F. Godinez-Azcuaga	J. F. Halley, <i>Contributing Member</i>
C. Hansen	R. W. Kruzic, <i>Contributing Member</i>
R. W. Hardy	L. E. Mullins, <i>Contributing Member</i>
G. W. Hembree	C. Wassink, <i>Contributing Member</i>
F. B. Kovacs	

**Working Group on Radiography (SG-VM) (BPV V)**

C. Vorwald, <i>Chair</i>	B. D. Laite
D. M. Woodward, <i>Vice Chair</i>	T. R. Lerohl
D. Bajula	C. May
P. L. Brown	R. J. Mills
C. Emslander	J. F. Molinaro
A. F. Garbolevsky	N. Pasemko
R. W. Hardy	J. Schoneweis
G. W. Hembree	T. L. Clifford, <i>Contributing Member</i>
P. Howie	R. W. Kruzic, <i>Contributing Member</i>
F. B. Kovacs	

**Working Group on Ultrasonics (SG-VM) (BPV V)**

K. Krueger, <i>Chair</i>	C. May
D. Bajula, <i>Vice Chair</i>	E. Peloquin
D. Adkins	J. Schoneweis
C. T. Brown	D. Van Allen
C. Emslander	C. Vorwald
N. A. Finney	J. F. Halley, <i>Contributing Member</i>
P. Furr	R. W. Kruzic, <i>Contributing Member</i>
C. Hansen	P. Mudge, <i>Contributing Member</i>
P. T. Hayes	L. E. Mullins, <i>Contributing Member</i>
G. W. Hembree	M. J. Quarry, <i>Contributing Member</i>
B. D. Laite	J. Vanvelsor, <i>Contributing Member</i>
T. R. Lerohl	

**Special Working Group for Advance UT Techniques (WG-UT) (BPV V)**

K. Krueger, <i>Chair</i>	P. Hayes
J. Schoneweis, <i>Vice Chair</i>	B. D. Laite
D. Bajula	T. R. Lerohl
C. David	E. Peloquin
N. A. Finney	D. Tompkins
P. Furr	D. Van Allen
J. Garner	C. Wassink
C. Hansen	

**Working Group on Acoustic Emissions (SG-VM) (BPV V)**

V. F. Godinez-Azcuaga, <i>Chair</i>	S. R. Doctor
J. Catty, <i>Vice Chair</i>	N. F. Douglas, Jr.

**Working Group on Full Matrix Capture (SG-VM) (BPV V)**

E. Peloquin, <i>Chair</i>	M. Lozev
P. T. Hayes, <i>Vice Chair</i>	R. Nogueira
D. Bajula	D. Richard
J. Catty	M. Sens
N. A. Finney	D. Tompkins
J. L. Garner	J. F. Halley, <i>Contributing Member</i>
R. T. Grotenhuis	L. E. Mullins, <i>Contributing Member</i>
G. W. Hembree	C. Wassink, <i>Contributing Member</i>
K. Krueger	

**Subgroup on Inservice Examination Methods and Techniques (BPV V)**

P. T. Hayes, <i>Chair</i>	V. F. Godinez-Azcuaga
E. Peloquin, <i>Vice Chair</i>	C. Hansen
D. Bajula	G. W. Hembree
R. Barker	K. Krueger
R. J. Bunte	C. May
M. A. Burns	N. Pasemko
M. Carlson	D. D. Raimander
T. Demmer	B. Ray
N. Douglas, Jr.	J. Schoneweis
N. A. Finney	C. Vorwald

**Working Group on Assisted Analysis (SG-ISI) (BPV V)**

T. Demmer, <i>Chair</i>	G. W. Hembree
C. Hansen, <i>Vice Chair</i>	G. I. Kraljic
J. Aldrin	G. M. Lozev
J. Chen	R. S. F. Orozco
M. Elen	E. Peloquin
N. A. Finney	T. Thulien
V. F. Godinez-Azcuaga	J. Williams
R. T. Grotenhuis	S. Zafar
K. Hayes	

**Working Group on Methods and Techniques (SG-ISI) (BPV V)**

C. May, <i>Chair</i>	P. T. Hayes
R. J. Bunte, <i>Vice Chair</i>	K. Krueger
D. Bajula	B. D. Laite
R. Barker	G. Morais
M. A. Burns	N. Pasemko
M. Carlson	J. Schoneweis
J. Catty	

**Working Group on Supplemental Requirements for Corrosion and Other Damage Mechanisms (SG-ISI) (BPV V)**

J. Schoneweis, <i>Chair</i>	C. Hansen
N. Pasemko, <i>Vice Chair</i>	P. T. Hayes
D. Bajula	K. Krueger
R. Barker	E. Peloquin
N. A. Finney	I. Roux

**Subgroup on Surface Examination Methods (BPV V)**

B. D. Laite, <i>Chair</i>	C. May
D. Bajula	G. Morais
R. Behe	J. Schoneweis
R. M. Beldyk	P. B. Shaw
P. L. Brown	R. Tedder
N. Carter	C. Vorwald
C. Emslander	D. M. Woodward
N. Farenbaugh	T. Clausing, <i>Contributing Member</i>
N. A. Finney	J. F. Halley, <i>Contributing Member</i>
A. F. Garbolevsky	K. Hayes, <i>Contributing Member</i>
G. W. Hembree	R. W. Kruzic, <i>Contributing Member</i>
K. Krueger	L. E. Mullins, <i>Contributing Member</i>
T. R. Lerohl	C. Wassink, <i>Contributing Member</i>

**Germany International Working Group (BPV V)**

P. Chavdarov, <i>Chair</i>	C. Kringe
V. Pohl, <i>Vice Chair</i>	S. Mann
H.-P. Schmitz, <i>Secretary</i>	V. Reusch
D. Kaiser	P. Van IJS

**India International Working Group (BPV V)**

P. Kumar, <i>Chair</i>	J. V. Muthukumaraswamy
A. V. Bhagwat, <i>Vice Chair</i>	A. Relekar
V. Ligade, <i>Secretary</i>	V. J. Sonawane
S. Jobanputra	N. Suryawanshi
D. Joshi	D. B. Tanpure
G. R. Joshi	

**Italy International Working Group (BPV V)**

D. D. Raimander, <i>Chair</i>	E. Ferrari
O. Oldani, <i>Vice Chair</i>	M. A. Grimoldi
C. R. Ramcharran, <i>Staff Secretary</i>	G. Luoni
P. Campli, <i>Secretary</i>	U. Papponetti
M. Agostini	P. Pedersoli
T. Aldo	A. Veroni
F. Bresciani	M. Zambon
N. Caputo	G. Gobbi, <i>Contributing Member</i>
M. Colombo	A. Gusmaroli, <i>Contributing Member</i>
P. L. Dinelli	G. Pontiggia, <i>Contributing Member</i>
F. Ferrarese	

**COMMITTEE ON PRESSURE VESSELS (BPV VIII)**

S. C. Roberts, <i>Chair</i>	J. P. Swezy, Jr.
M. D. Lower, <i>Vice Chair</i>	S. Terada
J. Oh, <i>Staff Secretary</i>	E. Upitis
S. J. Rossi, <i>Staff Secretary</i>	A. Viet
S. R. Babka	K. Xu
L. Bower	K. Oyamada, <i>Delegate</i>
P. Chavdarov	M. E. Papponetti, <i>Delegate</i>
B. F. Hantz	G. Auriolles, Sr., <i>Contributing Member</i>
C. S. Hinson	R. J. Basile
J. Hoskinson	A. Chaudouet, <i>Contributing Member</i>
M. Kowalczyk	D. B. DeMichael, <i>Contributing Member</i>
D. L. Kurle	K. T. Lau, <i>Contributing Member</i>
R. Mahadeen	H. Michael, <i>Contributing Member</i>
S. A. Marks	R. W. Mikitka, <i>Contributing Member</i>
P. Matkovic	D. A. Swanson, <i>Contributing Member</i>
D. T. Peters	G. G. Karcher, <i>Honorary Member</i>
M. J. Pischke	U. R. Miller, <i>Honorary Member</i>
M. D. Rana	T. P. Pastor, <i>Honorary Member</i>
G. B. Rawls, Jr.	K. K. Tam, <i>Honorary Member</i>
F. L. Richter	
C. D. Rodery	
J. C. Sowinski	
D. Srnic	
P. L. Sturgill	
K. Subramanian	

**Executive Committee (BPV VIII)**

M. D. Lower, <i>Chair</i>	J. Hoskinson
S. J. Rossi, <i>Staff Secretary</i>	P. Matkovic
G. Auriolles, Sr.	S. C. Roberts
C. W. Cary	J. C. Sowinski
P. Chavdarov	K. Subramanian
T. Halligan	K. Xu

**Subgroup on Design (BPV VIII)**

J. C. Sowinski, <i>Chair</i>	S. Terada
C. S. Hinson, <i>Vice Chair</i>	K. Xu
S. R. Babka	K. Oyamada, <i>Delegate</i>
O. A. Barsky	M. E. Papponetti, <i>Delegate</i>
M. Faulkner	G. Auriolles, Sr., <i>Contributing Member</i>
D. Francis	R. J. Basile, <i>Contributing Member</i>
B. F. Hantz	D. Chandiramani, <i>Contributing Member</i>
C. E. Hinnant	M. H. Jawad, <i>Contributing Member</i>
S. Krishnamurthy	P. K. Lam, <i>Contributing Member</i>
D. L. Kurle	K. Mokhtarian, <i>Contributing Member</i>
K. Kescu	C. D. Rodery, <i>Contributing Member</i>
M. D. Lower	D. A. Swanson, <i>Contributing Member</i>
R. W. Mikitka	K. K. Tam, <i>Contributing Member</i>
B. Millet	E. Upitis, <i>Contributing Member</i>
M. D. Rana	
G. B. Rawls, Jr.	
S. C. Roberts	
T. G. Seipp	
D. Srnic	

**Working Group on Design-by-Analysis (BPV VIII)**

B. F. Hantz, *Chair*  
T. W. Norton, *Secretary*  
J. Bedoya  
A. Feller  
S. Guzey  
C. E. Hinnant  
S. Kataoka  
S. Kilambi  
K. D. Kirkpatrick

S. Krishnamurthy  
C. Nadarajah  
T. G. Seipp  
M. Shah  
S. Terada  
D. A. Arnett, *Contributing Member*  
A. Mann, *Contributing Member*  
K. Saboda, *Contributing Member*

**Working Group on Elevated Temperature Design (BPV I and VIII)**

C. Nadarajah, *Chair*  
L. S. Tsai, *Secretary*  
D. Anderson  
D. Dewees  
B. F. Hantz  
R. I. Jetter  
S. Kataoka  
S. Krishnamurthy  
S. R. Kummari  
T. Le  
B.-L. Lyow

C. T. McDaris  
M. C. Messner  
M. N. Mitchell  
P. Prueter  
A. Ramos  
M. Rathinasabapathy  
M. J. Swindeman  
A. Mann, *Contributing Member*  
N. McMurray, *Contributing Member*  
B. J. Mollitor, *Contributing Member*

**Subgroup on Fabrication and Examination (BPV VIII)**

T. Halligan, *Chair*  
D. I. Morris, *Vice Chair*  
D. Smith, *Secretary*  
J. Lu  
S. A. Marks  
O. Mulet  
M. J. Pischke  
M. J. Rice  
J. Roberts  
C. D. Rodery

B. F. Shelley  
P. L. Sturgill  
J. P. Swezy, Jr.  
E. Uptis  
C. Violand  
K. Oyamada, *Delegate*  
W. J. Bees, *Contributing Member*  
L. F. Campbell, *Contributing Member*  
N. Carter, *Contributing Member*

**Subgroup on General Requirements (BPV VIII)**

J. Hoskinson, *Chair*  
M. Faulkner, *Vice Chair*  
N. Barkley  
T. P. Beirne  
R. Darby  
Z. Jakovljevic  
M. D. Lower  
T. Newman  
I. A. Powell  
J. Qu  
G. B. Rawls, Jr.  
F. L. Richter  
S. C. Roberts

J. Rust  
P. T. Shanks  
J. C. Sowinski  
P. Speranza  
D. Srnic  
D. B. Stewart  
D. B. DeMichael, *Contributing Member*  
T. P. Pastor, *Contributing Member*  
R. Robles, *Contributing Member*  
D. A. Swanson, *Contributing Member*  
Y. Yang, *Contributing Member*

**Task Group on Electrochemical Cell Stacks (TG-ECS) (BPV VIII)**

K. Xu, *Chair*  
K. Quackenbush, *Vice Chair*  
N. Barkley  
E. Gadsby  
S. Goyette  
T. Halligan  
R. Kauer  
P. Matkovic  
L. Moulthrop  
J. Panicker  
E. Prause  
P. T. Shanks  
S. Ulemek  
E. Andrade, *Contributing Member*  
B. D. Carter, *Contributing Member*

K. Choi, *Contributing Member*  
L. T. Dalton, *Contributing Member*  
M. Duda, *Contributing Member*  
R. Fournier, *Contributing Member*  
E. Gernot, *Contributing Member*  
S. Grimm, *Contributing Member*  
N. Hart, *Contributing Member*  
R. Müller, *Contributing Member*  
P. K. Panigrahy, *Contributing Member*  
R. Robles, *Contributing Member*  
M. Stelzel, *Contributing Member*  
M. Sweetland, *Contributing Member*

**Task Group on Fired Heater Pressure Vessels (BPV VIII)**

J. Hoskinson, *Chair*  
D. Nelson  
R. Robles  
J. Rust

P. T. Shanks  
E. Smith  
D. Srnic

**Subgroup on Heat Transfer Equipment (BPV VIII)**

P. Matkovic, *Chair*  
L. Bower, *Vice Chair*  
T. Bunyarattaphantu, *Secretary*  
S. R. Babka  
J. H. Barbee  
O. A. Barsky  
A. Chaudouet  
D. L. Kurle  
R. Mahadeen  
S. Mayeux  
S. Neilsen

E. Smith  
A. M. Voytko  
R. P. Wiberg  
G. Auriolles, Sr., *Contributing Member*  
K. M. Chikhaliya, *Contributing Member*  
J. Pasek, *Contributing Member*  
D. Srnic, *Contributing Member*  
Z. Tong, *Contributing Member*

**Working Group on Plate Heat Exchangers (BPV VIII)**

D. I. Morris, *Chair*  
S. R. Babka  
V. Gudge  
T. Halligan  
Z. Jakovljevic

P. Matkovic  
M. J. Pischke  
P. T. Shanks  
E. Smith  
D. Srnic

**Subgroup on High Pressure Vessels (BPV VIII)**

K. Subramanian, <i>Chair</i>	F. W. Tatar
M. Sarzynski, <i>Vice Chair</i>	S. Terada
A. Dinizulu, <i>Staff Secretary</i>	Y. Xu
L. P. Antalffy	A. M. Clayton, <i>Contributing Member</i>
N. Barkley	R. Cordes, <i>Contributing Member</i>
J. Barlow	R. D. Dixon, <i>Contributing Member</i>
R. C. Biel	J. Hademenos, <i>Contributing Member</i>
P. N. Chaku	R. M. Hoshman, <i>Contributing Member</i>
L. Fridlund	F. Kirkemo, <i>Contributing Member</i>
D. Fuenmayor	G. M. Mital, <i>Contributing Member</i>
J. Gibson	M. Parr, <i>Contributing Member</i>
R. T. Hallman	M. D. Rana, <i>Contributing Member</i>
K. Karpanan	C. Tipple, <i>Contributing Member</i>
A. K. Khare	K.-J. Young, <i>Contributing Member</i>
G. T. Nelson	D. J. Burns, <i>Honorary Member</i>
D. T. Peters	G. J. Mraz, <i>Honorary Member</i>
E. D. Roll	
J. R. Sims	
E. Smith	

**Subgroup on Materials (BPV VIII)**

P. Chavdarov, <i>Chair</i>	D. Pugh
M. Kowalczyk, <i>Vice Chair</i>	D. W. Rahoi
S. Kilambi, <i>Secretary</i>	E. Uptis
J. Cameron	K. Xu
H. Dutta	M. Katcher, <i>Contributing Member</i>
J. F. Grubb	R. C. Sutherlin, <i>Contributing Member</i>
D. Maitra	
R. K. Patadia	

**Subgroup on Toughness (BPV VIII)**

K. Xu, <i>Chair</i>	J. P. Swezy, Jr.
T. Halligan, <i>Vice Chair</i>	S. Terada
T. Finn	E. Uptis
C. S. Hinson	J. Vattappilly
S. Kilambi	K. Oyamada, <i>Delegate</i>
D. L. Kurle	L. Dong, <i>Contributing Member</i>
T. Newman	S. Krishnamurthy, <i>Contributing Member</i>
J. Qu	D. A. Swanson, <i>Contributing Member</i>
M. D. Rana	
F. L. Richter	
K. Subramanian	

**Subgroup on Graphite Pressure Equipment (BPV VIII)**

C. W. Cary, <i>Chair</i>	H. Lee, Jr.
A. Viet, <i>Vice Chair</i>	S. Mehrez
G. C. Becherer	T. Rudy
F. L. Brown	A. A. Stupica
J. D. Clements	J. Wince

**Argentina International Working Group (BPV VIII)**

A. Dominguez, <i>Chair</i>	M. A. Mendez
R. Robles, <i>Vice Chair</i>	J. J. Monaco
G. Glissent, <i>Secretary</i>	C. Parente
A. Antipasti	M. A. A. Pipponzi
D. A. Bardelli	L. C. Rigoli
R. A. Barey	A. Rivas
O. S. Bretones	D. Rizzo
A. Burgueno	M. A. Sena
G. Casanas	G. Telleria
D. A. Del Teglia	C. Alderetes, <i>Contributing Member</i>
M. Favareto	D. H. Da Rold, <i>Contributing Member</i>
J. A. Labastidas	J. C. Rubeo, <i>Contributing Member</i>
F. P. Larrosa	

**China International Working Group (BPV VIII)**

X. Chen, <i>Chair</i>	C. Miao
B. Shou, <i>Vice Chair</i>	L. Sun
Z. Fan, <i>Secretary</i>	C. Wu
Y. Chen	J. Xiaobin
J. Cui	F. Xu
R. Duan	G. Xu
J.-G. Gong	F. Yang
B. Han	Y. Yang
J. Hu	Y. Yuan
Q. Hu	Yanfeng Zhang
H. Hui	Yijun Zhang
K. Li	S. Zhao
D. Luo	J. Zheng
Y. Luo	G. Zhu

**Germany International Working Group (BPV VIII)**

R. Kauer, <i>Chair</i>	S. Krebs
M. Sykora, <i>Vice Chair</i>	T. Ludwig
A. Aloui	R. A. Meyers
P. Chavdarov	H. Michael
M. Delzeit	R. Müller
A. Emrich	S. Reich
C. Jaekel	A. Spangenberg
S. Jetzlsperger	C. Stobbe
D. Koelbl	

**India International Working Group (BPV VIII)**

D. Chandiramani, <i>Chair</i>	T. Mukherjee
D. Kulkarni, <i>Vice Chair</i>	P. C. Pathak
A. D. Dalal, <i>Secretary</i>	D. Prabhu
P. Arulkumar	A. Sadasivam
P. Gandhi	M. P. Shah
U. Ganesan	Y. Z. Shaikh
S. K. Goyal	R. Tiru
V. Jayabalan	V. T. Valavan
V. K. Joshi	M. Sharma, <i>Contributing Member</i>
A. Kakumanu	

**Italy International Working Group (BPV VIII)**

M. Millefanti, *Chair*  
P. Campli, *Secretary*  
P. Aliprandi  
A. Avogadri  
A. Camanni  
M. Camposaragna  
N. Caputo  
M. Colombo  
P. Conti  
D. Cortassa  
A. Fabiano  
F. Finco  
M. Guglielmetti

A. F. Magri  
L. Moracchioli  
P. Pacor  
S. Sarti  
A. Teli  
N. Wagner  
V. Calo, *Contributing Member*  
G. Gobbi, *Contributing Member*  
A. Gusmaroli, *Contributing Member*  
G. Pontiggia, *Contributing Member*  
D. D. Raimander, *Contributing Member*

**Special Working Group on Bolted Flanged Joints (BPV VIII)**

W. Brown, *Chair*  
M. Osterfoss, *Vice Chair*  
D. Bankston, Jr.  
C. W. Cary  
A. Chaudouet  
H. Chen  
D. Francis  
H. Lejeune  
A. Mann  
W. McDaniel

R. W. Mikitka  
D. Nash  
M. Ruffin  
M. Siddiqui  
E. Jamalyaria, *Contributing Member*  
G. Van Zyl, *Contributing Member*  
J. Veiga, *Contributing Member*  
R. Wacker, *Contributing Member*

**Subgroup on Interpretations (BPV VIII)**

P. Matkovic, *Chair*  
J. Oh, *Staff Secretary*  
S. R. Babka  
L. Bower  
T. Bunyarattaphantu  
J. Cameron  
C. W. Cary  
P. Chavdarov  
M. Faulkner  
T. Halligan  
B. F. Hantz  
J. Hoskinson  
M. Kowalczyk  
D. L. Kurle  
K. Kusu  
M. D. Lower  
S. A. Marks  
D. I. Morris

D. T. Peters  
J. Qu  
F. L. Richter  
S. C. Roberts  
C. D. Rodery  
T. G. Seipp  
E. Smith  
J. C. Sowinski  
K. Subramanian  
J. P. Swezy, Jr.  
A. Viet  
K. Xu  
G. Auriolos, Sr., *Contributing Member*  
R. J. Basile, *Contributing Member*  
D. A. Swanson, *Contributing Member*

**COMMITTEE ON WELDING, BRAZING, AND FUSING (BPV IX)**

M. J. Pischke, *Chair*  
P. L. Sturgill, *Vice Chair*  
R. Rahaman, *Staff Secretary*  
D. Barborak  
M. Bernasek  
M. A. Boring  
D. A. Bowers  
N. Carter  
J. G. Feldstein  
P. Gilston  
S. E. Gingrich  
K. L. Hayes  
J. S. Lee  
W. M. Lundy  
D. W. Mann  
S. A. Marks  
T. Melfi  
W. F. Newell, Jr.

E. G. Reichelt  
M. J. Rice  
W. J. Sperko  
J. P. Swezy, Jr.  
A. D. Wilson  
L. Costa, *Delegate*  
D. Pojatar, *Delegate*  
D. D. Raimander, *Delegate*  
A. Roza, *Delegate*  
M. Consonni, *Contributing Member*  
R. M. Jessee, *Contributing Member*  
P. L. Van Fosson, *Contributing Member*  
R. K. Brown, Jr., *Honorary Member*  
M. L. Carpenter, *Honorary Member*  
B. R. Newmark, *Honorary Member*  
S. D. Reynolds, Jr., *Honorary Member*

**Subgroup on Brazing (BPV IX)**

S. A. Marks, *Chair*  
E. W. Beckman  
A. F. Garbolevsky  
N. Mohr

M. J. Pischke  
P. L. Sturgill  
J. P. Swezy, Jr.

**Subgroup on General Requirements (BPV IX)**

N. Carter, *Chair*  
P. Gilston, *Vice Chair*  
S. A. Marks, *Secretary*  
J. P. Bell  
D. A. Bowers  
T. Bunyarattaphantu  
M. Cox  
M. Heinrichs  
R. M. Jessee  
P. Matkovic  
W. May

K. Meszaros  
H. B. Porter  
D. Smith  
P. L. Sturgill  
J. P. Swezy, Jr.  
E. W. Woelfel  
L. Costa, *Delegate*  
E. W. Beckman, *Contributing Member*  
A. Davis, *Contributing Member*  
B. R. Newmark, *Honorary Member*

**Subgroup on Materials (BPV IX)**

M. Bernasek, *Chair*  
T. Anderson  
L. Constantinescu  
E. Cutlip  
S. E. Gingrich  
L. S. Harbison  
M. James  
R. M. Jessee  
T. Melfi  
S. D. Nelson  
M. J. Pischke

D. D. Raimander  
A. Roza  
C. E. Sainz  
P. L. Sturgill  
C. Zafir  
L. Costa, *Delegate*  
V. G. V. Giunto, *Delegate*  
D. J. Kotecki, *Contributing Member*  
B. Krueger, *Contributing Member*  
W. J. Sperko, *Contributing Member*  
M. J. Stanko, *Contributing Member*

**Subgroup on Plastic Fusing (BPV IX)**

K. L. Hayes, *Chair*  
M. Brandes  
R. M. Jessee  
J. Johnston, Jr.  
J. E. O'Sullivan  
E. G. Reichelt

M. J. Rice  
S. Schuessler  
M. Troughton  
C. Violand  
E. W. Woelfel  
J. Wright

**Subgroup on Welding Qualifications (BPV IX)**

T. Melfi, <i>Chair</i>	M. J. Rice
A. D. Wilson, <i>Vice Chair</i>	M. B. Sims
K. L. Hayes, <i>Secretary</i>	A. Spangenberg
M. Bernasek	W. J. Sperko
M. A. Boring	P. L. Sturgill
D. A. Bowers	J. P. Swezy, Jr.
R. Campbell	C. Violand
R. B. Corbit	L. Costa, <i>Delegate</i>
L. S. Harbison	D. D. Raimander, <i>Delegate</i>
M. Heinrichs	D. Chandiramani, <i>Contributing Member</i>
J. S. Lee	M. Consonni, <i>Contributing Member</i>
W. M. Lundy	M. Dehghan, <i>Contributing Member</i>
D. W. Mann	T. C. Wiesner, <i>Contributing Member</i>
K. Meszaros	
W. F. Newell, Jr.	
E. G. Reichelt	

**Argentina International Working Group (BPV IX)**

A. Burgueno, <i>Chair</i>	J. Caprarulo
A. R. G. Frinchaboy, <i>Vice Chair</i>	M. Favareto
R. Rahaman, <i>Staff Secretary</i>	J. A. Gandola
M. D. Kuhn, <i>Secretary</i>	M. A. Mendez
P. J. Cabot	A. E. Pastor

**Germany International Working Group (BPV IX)**

P. Chavadarov, <i>Chair</i>	P. Müller
R. Rahaman, <i>Staff Secretary</i>	S. Wegener
P. Khwaja, <i>Secretary</i>	J. Daldrup, <i>Contributing Member</i>
B. Daume	E. Floer, <i>Contributing Member</i>
D. Haase	A. Scherpenisse, <i>Contributing Member</i>
S. Krebs	K.-G. Toelle, <i>Contributing Member</i>
T. Ludwig	

**Italy International Working Group (BPV IX)**

D. D. Raimander, <i>Chair</i>	P. Pacor
F. Ferrarese, <i>Vice Chair</i>	G. Signoretta
R. Rahaman, <i>Staff Secretary</i>	V. Calo, <i>Contributing Member</i>
P. Campli, <i>Secretary</i>	G. Gobbi, <i>Contributing Member</i>
M. Bernasek	A. Gusmaroli, <i>Contributing Member</i>
A. Camanni	G. Pontiggia, <i>Contributing Member</i>
M. Mandina	P. Siboni, <i>Contributing Member</i>
A. S. Monastra	
L. Moracchioli	

**Spain International Working Group (BPV IX)**

F. J. Q. Pandelo, <i>Chair</i>	B. B. Miguel
F. Manas, <i>Vice Chair</i>	A. D. G. Munoz
R. Rahaman, <i>Staff Secretary</i>	A. B. Pascual
F. R. Hermidia, <i>Secretary</i>	G. Gobbi, <i>Contributing Member</i>
C. A. Celimendiz	R. G. Garcia, <i>Contributing Member</i>
M. A. F. Garcia	

**COMMITTEE ON FIBER-REINFORCED PLASTIC PRESSURE VESSELS (BPV X)**

J. L. Bustillos, <i>Chair</i>	D. H. McCauley
D. Eisberg, <i>Vice Chair</i>	N. L. Newhouse
C. R. Ramcharran, <i>Staff Secretary</i>	G. Ramirez
A. L. Beckwith	J. R. Richter
B. R. Colley	B. F. Shelley
T. W. Cowley	G. A. Van Beek
I. L. Dinovo	S. L. Wagner
J. Eihusen	D. O. Yancey, Jr.
K. L. Gilmore	P. H. Ziehl
M. R. Gorman	D. H. Hodgkinson, <i>Contributing Member</i>
B. Hebb	D. L. Keeler, <i>Contributing Member</i>
L. E. Hunt	
B. Linnemann	

**COMMITTEE ON NUCLEAR INSERVICE INSPECTION (BPV XI)**

D. W. Lamond, <i>Chair</i>	G. C. Park
S. D. Kulat, <i>Vice Chair</i>	D. A. Scarth
A. T. Roberts III, <i>Vice Chair</i>	F. J. Schaaf, Jr.
D. Miro-Quesada, <i>Staff Secretary</i>	R. W. Swayne
M. L. Benson	S. Takaya
C. T. Brown	A. Udyawar
S. B. Brown	D. Vetter
T. L. Chan	J. G. Weicks
R. C. Cipolla	M. Weis
R. Clow	B. K. Welch
D. R. Cordes	Y.-K. Chung, <i>Delegate</i>
H. Do	C. Ye, <i>Delegate</i>
E. V. Farrell, Jr.	M. Homiack, <i>Alternate</i>
M. J. Ferlisi	C. Latiolais, <i>Alternate</i>
J. Hakii	R. O. McGill, <i>Alternate</i>
M. L. Hall	T. J. Griesbach, <i>Contributing Member</i>
P. J. Hennessey	J. T. Lindberg, <i>Contributing Member</i>
D. O. Henry	T. V. Vo, <i>Contributing Member</i>
R. Hinkle	C. D. Cowfer, <i>Honorary Member</i>
K. Hojo	E. B. Gerlach, <i>Honorary Member</i>
A. E. Keyser	R. E. Gimple, <i>Honorary Member</i>
H. Malikowski	F. E. Gregor, <i>Honorary Member</i>
S. L. McCracken	R. D. Kerr, <i>Honorary Member</i>
L. A. Melder	P. C. Riccardella, <i>Honorary Member</i>
S. A. Norman	R. A. West, <i>Honorary Member</i>
T. Nuoffer	C. J. Wirtz, <i>Honorary Member</i>
J. Nygaard	R. A. Yonekawa, <i>Honorary Member</i>
J. E. O'Sullivan	
N. A. Palm	

**Executive Committee (BPV XI)**

S. D. Kulat, <i>Chair</i>	N. A. Palm
D. W. Lamond, <i>Vice Chair</i>	G. C. Park
D. Miro-Quesada, <i>Staff Secretary</i>	A. T. Roberts III
M. L. Benson	R. W. Swayne
M. J. Ferlisi	D. Vetter
D. O. Henry	M. Homiack, <i>Alternate</i>
S. L. McCracken	

**Latin American International Working Group (BPV XI)**

O. Martinez, <i>Staff Secretary</i>	F. J. Schaaf, Jr.
A. Claus	F. M. Schroeter
I. M. Guerreiro	P. Yamamoto
L. R. Miño	

**China International Working Group (BPV XI)**

T. Yuchun, <i>Chair</i>	W. N. Pei
J. F. Cai, <i>Vice Chair</i>	L. Shiwei
C. Ye, <i>Vice Chair</i>	S. Shuo
M. W. Zhou, <i>Secretary</i>	Y. Sixin
M. Chao	Y. X. Sun
H. D. Chen	Z. Wan
Y. Cheng	Q. Wang
C. Gao	Q. W. Wang
Y. Guanghua	Z. S. Wang
Y. B. Guo	L. Xing
Y. Hongqi	F. Xu
D. R. Horn	S. X. Xu
Y. Hou	Q. Yin
Y. S. Li	Y. Zhe
Shangyuan Liu	Z. M. Zhong
Y. Nie	

**Working Group on Spent Nuclear Fuel Storage and Transportation Containment Systems (BPV XI)**

K. Hunter, <i>Chair</i>	K. Mauskar
M. Orihuela, <i>Secretary</i>	R. M. Meyer
D. J. Ammerman	R. M. Pace
J. Broussard	M. A. Richter
C. R. Bryan	B. Sarno
T. Carraher	R. Sindelar
D. Dunn	M. Staley
N. Fales	J. Tatman
R. C. Folley	J. Wellwood
A. Gonzalez	K. A. Whitney
G. Grant	X. J. Zhai
B. Gutherman	P.-S. Lam, <i>Alternate</i>
M. W. Joseph	G. White, <i>Alternate</i>
M. Keene	H. Smith, <i>Contributing Member</i>
M. Liu	

**European International Working Group (BPV XI)**

R. Döring, <i>Chair</i>	H.-W. Lange
M. Hagenbruch, <i>Vice Chair</i>	N. Legl
R. Piel, <i>Secretary</i>	T. Ludwig
P. Ancion	M. Reichert
A. Casse	L. Sybertz
C. G. Frantescu	I. Tewes
T. Hantzka	R. Tiete
E. Iacopetta	Yixing Wang
A. Juengert	J. Wendt
S. D. Kulat	

**Task Group on Mitigation and Repair of Spent Nuclear Fuel Canisters (WG-SNFS & TCS) (BPV XI)**

J. Tatman, <i>Chair</i>	M. Kris
D. J. Ammerman	M. Liu
J. Broussard	K. Mauskar
C. R. Bryan	S. L. McCracken
G. R. Cannell	M. Orihuela
K. Dietrich	M. Richter
D. Dunn	K. E. Ross
N. Fales	B. Sarno
R. C. Folley	R. Sindelar
D. Jacobs	J. Wellwood
N. Klymyshyn	A. Williams

**India International Working Group (BPV XI)**

S. B. Parkash, <i>Chair</i>	K. K. Rai
D. Narain, <i>Vice Chair</i>	D. Rawal
Z. M. Mansuri	R. Sahai
M. R. Nadgouda	R. K. Sharma
N. Palm	

**Subgroup on Evaluation Standards (BPV XI)**

N. A. Palm, <i>Chair</i>	R. O. McGill
S. X. Xu, <i>Secretary</i>	R. M. Pace
M. L. Benson	S. Ranganath
R. C. Cipolla	C. J. Sallaberry
C. M. Faigy	D. A. Scarth
M. M. Farooq	D. J. Shim
T. J. Griesbach	A. Udyawar
K. Hojo	T. V. Vo
M. Kirk	G. M. Wilkowski
D. R. Lee	K. Hasegawa, <i>Contributing Member</i>
Y. S. Li	H. S. Mehta, <i>Contributing Member</i>

**Special Working Group on Editing and Review (BPV XI)**

R. W. Swayne, <i>Chair</i>	M. Orihuela
R. C. Cipolla	D. A. Scarth
D. O. Henry	A. Udyawar

**Task Group on Inspectability (BPV XI)**

E. Henry, <i>Chair</i>	J. Honcharik
B. Langston, <i>Secretary</i>	C. Latiolais
D. Brown	J. T. Lindberg
A. Bushmire	L. Loomis
A. Cardillo	S. Matsumoto
K. Caver	D. E. Matthews
D. R. Cordes	P. J. O'Regan
D. O. Henry	J. B. Ossmann

**Task Group on Evaluation of Beyond Design Basis Events (SG-ES) (BPV XI)**

R. M. Pace, <i>Chair</i>	S. A. Kleinsmith
S. X. Xu, <i>Secretary</i>	M. Moenssens
G. A. Antaki	T. V. Vo
P. R. Donavin	K. Voelsing
R. G. Gilada	G. M. Wilkowski
T. J. Griesbach	F. G. Abatt, <i>Contributing Member</i>
M. Hayashi	H. S. Mehta, <i>Contributing Member</i>
K. Hojo	

**Working Group on Flaw Evaluation  
(SG-ES) (BPV XI)**

R. C. Cipolla, <i>Chair</i>	C. Liu
S. X. Xu, <i>Secretary</i>	M. Liu
M. L. Benson	G. A. Miessi
H. D. Chung	S. Noronha
N. G. Cofie	R. K. Qashu
M. A. Erickson	D. A. Scarth
C. M. Faidy	W. L. Server
M. M. Farooq	D. J. Shim
B. R. Ganta	S. Smith
R. G. Gilada	M. Uddin
C. Guzman-Leong	A. Udyawar
K. Hojo	T. V. Vo
F. Iwamatsu	M. Walter
S. Kalyanam	K. Wang
Y. Kim	B. Wasiluk
V. Lacroix	G. M. Wilkowski
D. R. Lee	H. S. Mehta, <i>Contributing Member</i>
Y. S. Li	

**Working Group on Flaw Evaluation Reference Curves  
(SG-ES) (BPV XI)**

A. Udyawar, <i>Chair</i>	A. Morley
D. A. Scarth, <i>Secretary</i>	B. Pellereau
M. L. Benson	S. Ranganath
F. W. Brust	D. J. Shim
R. C. Cipolla	S. Smith
M. M. Farooq	M. Uddin
A. E. Freed	T. V. Vo
K. Hasegawa	G. White
K. Hojo	S. X. Xu
F. Iwamatsu	H. S. Mehta, <i>Contributing Member</i>
V. Lacroix	

**Working Group on High Temperature Flaw Evaluation  
(SG-ES) (BPV XI)**

C. J. Sallaberry, <i>Chair</i>	M. Petkov
F. W. Brust	H. Qian
P. Carter	D. A. Scarth
K. Gresh	D. J. Shim
S. Kalyanam	A. Udyawar
B. Lin	X. Wei
B.-L. Lyow	S. X. Xu
M. C. Messner	J. Bass, <i>Alternate</i>

**Working Group on Operating Plant Criteria (SG-ES) (BPV XI)**

M. Kirk, <i>Chair</i>	R. M. Pace
D. Rudland, <i>Secretary</i>	N. A. Palm
D. B. Denis	S. Ranganath
M. A. Erickson	W. L. Server
A. E. Freed	C. A. Tomes
T. J. Griesbach	A. Udyawar
B. Hall	T. V. Vo
M. Hayashi	H. Q. Xu
R. Janowiak	M. Yamamoto
S. A. Kleinsmith	E. Haywood, <i>Alternate</i>
H. Kobayashi	H. S. Mehta, <i>Contributing Member</i>
A. D. Odell	

**Task Group on Appendix L (WG-OPC) (SG-ES) (BPV XI)**

N. Glunt, <i>Chair</i>	A. D. Odell
R. M. Pace, <i>Secretary</i>	C.-S. Oh
C. Coleman	H. Park
J. I. Duo	S. Ranganath
A. E. Freed	A. Scott
M. A. Gray	D. J. Shim
T. J. Griesbach	S. Smith
H. Nam	A. Udyawar
A. Nana	T. V. Vo

**Working Group on Pipe Flaw Evaluation (SG-ES) (BPV XI)**

D. A. Scarth, <i>Chair</i>	Y. S. Li
S. Kalyanam, <i>Secretary</i>	R. O. McGill
K. Azuma	G. A. Miessi
F. W. Brust	S. M. Parker
H. D. Chung	S. H. Pellet
R. C. Cipolla	D. Rudland
N. G. Cofie	C. J. Sallaberry
C. M. Faidy	W. L. Server
M. M. Farooq	D. J. Shim
B. R. Ganta	S. Smith
R. G. Gilada	M. F. Uddin
S. R. Gosselin	A. Udyawar
C. E. Guzman-Leong	T. V. Vo
K. Hasegawa	K. Wang
K. Hojo	B. Wasiluk
D. N. Hopkins	G. M. Wilkowski
E. J. Houston	S. X. Xu
F. Iwamatsu	Y. Zou
R. Janowiak	K. Gresh, <i>Alternate</i>
Y. Kim	H. S. Mehta, <i>Contributing Member</i>
V. Lacroix	

**Task Group on Code Case N-513 (WG-PFE) (SG-ES) (BPV XI)**

R. O. McGill, <i>Chair</i>	R. Janowiak
S. M. Parker, <i>Secretary</i>	M. Kassir
G. A. Antaki	S. H. Pellet
R. C. Cipolla	D. Rudland
M. M. Farooq	D. A. Scarth
K. Gresh	S. X. Xu
E. J. Houston	

**Task Group on Evaluation Procedures for Degraded Buried Pipe  
(WG-PFE) (SG-ES) (BPV XI)**

R. O. McGill, <i>Chair</i>	M. Kassir
S. X. Xu, <i>Secretary</i>	M. Moenssens
F. G. Abatt	R. M. Pace
G. A. Antaki	S. H. Pellet
R. C. Cipolla	D. Rudland
R. G. Gilada	D. A. Scarth
R. Janowiak	

**Task Group on Flaw Evaluation for HDPE Pipe  
(WG-PFE) (SG-ES) (BPV XI)**

S. Kalyanam, <i>Chair</i>	D. J. Shim
P. Krishnaswamy	M. Troughton
C. Liu	R. Wolfe
M. Moenssens	J. Wright
D. P. Munson	S. X. Xu
D. A. Scarth	

**Subgroup on Nondestructive Examination (BPV XI)**

D. O. Henry, <i>Chair</i>	J. Harrison
T. Cinson, <i>Secretary</i>	D. A. Kull
C. T. Brown	C. Latiolais
A. Bushmire	J. T. Lindberg
T. L. Chan	F. J. Schaaf, Jr.
D. R. Cordes	D. R. Slivon
S. E. Cumblidge	R. V. Swain
K. J. Hacker	C. A. Nove, <i>Alternate</i>

**Task Group on Nonmetallic Component Degradation and Failure Monitoring (SG-RIM) (BPV XI)**

M. P. Metcalfe, <i>Chair</i>	N. Craft
A. Tzelepi, <i>Secretary</i>	W. J. Geringer
M. T. Audrain	K. Harris
S. Baylis	P.-A. Juan
G. Beirnaert	J. Lang
A. A. Campbell	C. Marks
C. Chen	J. Potgieter

**Working Group on Personnel Qualification and Surface Visual and Eddy Current Examination (SG-NDE) (BPV XI)**

C. T. Brown, <i>Chair</i>	D. O. Henry
M. Orihuela, <i>Secretary</i>	B. Langston
D. Brown	C. Shinsky
T. Cinson	R. Tedder
S. E. Cumblidge	T. Thulien
N. Farenbaugh	J. T. Timm
J. Harrison	

**ASME/JSME Joint Working Group on RIM Processes and System-Based Code (SG-RIM) (BPV XI)**

S. Takaya, <i>Chair</i>	R. Meyer
C. Wax, <i>Vice Chair</i>	T. Muraki
M. T. Audrain	S. Okajima
K. Dozaki	A. T. Roberts III
J. T. Fong	C. J. Sallaberry
J. Hakii	F. J. Schaaf, Jr.
K. Harris	R. Vayda
M. Hayashi	D. Watanabe
S. Kalyanam	H. Yada
D. R. Lee	K. Yamada
H. Machida	T. Asayama, <i>Contributing Member</i>
M. Mallet	T. Lupold, <i>Contributing Member</i>
R. J. McReynolds	

**Working Group on Procedure Qualification and Volumetric Examination (SG-NDE) (BPV XI)**

J. Harrison, <i>Chair</i>	C. Latiolais
D. A. Kull, <i>Secretary</i>	C. A. Nove
A. Bushmire	D. R. Slivon
D. R. Cordes	R. V. Swain
K. J. Hacker	D. Van Allen
R. E. Jacob	J. Williams
W. A. Jensen	B. Lin, <i>Alternate</i>

**Subgroup on Repair/Replacement Activities (BPV XI)**

S. L. McCracken, <i>Chair</i>	L. A. Melder
E. V. Farrell, Jr., <i>Secretary</i>	G. T. Olson
M. Brandes	J. E. O'Sullivan
S. B. Brown	G. C. Park
R. Clow	A. Patel
S. J. Findlan	R. A. Patel
M. L. Hall	R. R. Stevenson
R. Hinkle	R. W. Swayne
J. Honcharik	J. G. Weicks
A. B. Meichler	

**Subgroup on Reliability and Integrity Management Program (BPV XI)**

A. T. Roberts III, <i>Chair</i>	M. P. Metcalfe
D. Vetter, <i>Secretary</i>	R. Meyer
T. Anselmi	M. Orihuela
M. T. Audrain	C. J. Sallaberry
N. Broom	F. J. Schaaf, Jr.
F. W. Brust	H. M. Stephens, Jr.
S. R. Doctor	R. W. Swayne
J. D. Fletcher	S. Takaya
J. T. Fong	C. Wax
K. Harris	B. K. Welch
P. J. Hennessey	R. W. Youngblood
S. Kalyanam	B. Lin, <i>Alternate</i>
D. R. Lee	V. Chugh, <i>Contributing Member</i>
C. Mallet	R. Grantom, <i>Contributing Member</i>
R. J. McReynolds	T. Lupold, <i>Contributing Member</i>

**Working Group on Design and Programs (SG-RRR) (BPV XI)**

S. B. Brown, <i>Chair</i>	A. B. Meichler
R. A. Patel, <i>Secretary</i>	G. C. Park
O. Bhatti	M. A. Pyne
R. Clow	A. Rezaei
R. R. Croft	R. R. Stevenson
E. V. Farrell, Jr.	K. Sullivan
K. Harris	R. W. Swayne
H. Malikowski	

**Working Group on MANDE (SG-RIM) (BPV XI)**

H. M. Stephens, Jr., <i>Chair</i>	J. T. Fong
M. Orihuela, <i>Vice Chair</i>	D. O. Henry
M. Turnbow, <i>Secretary</i>	R. J. McReynolds
T. Anselmi	R. Meyer
M. T. Audrain	K. Yamada
S. R. Doctor	T. Lupold, <i>Contributing Member</i>
N. A. Finney	

**Task Group on Repair and Replacement Optimization (WG-D&P) (SG-RRR) (BPV XI)**

S. L. McCracken, <i>Chair</i>	M. L. Hall
S. J. Findlan, <i>Secretary</i>	D. Jacobs
T. Basso	H. Malikowski
R. Clow	G. C. Park
K. Dietrich	A. Patel
E. V. Farrell, Jr.	R. R. Stevenson
M. J. Ferlisi	J. G. Weicks
R. C. Folley	

**Working Group on Nonmetals Repair/Replacement Activities  
(SG-RRR) (BPV XI)**

J. E. O'Sullivan, <i>Chair</i>	A. Rezaei
S. Schuessler, <i>Secretary</i>	S. Rios
M. Brandes	F. J. Schaaf, Jr.
S. W. Choi	R. Stakenborghs
M. Golliet	P. Vibien
J. Johnston, Jr.	M. P. Marohl, <i>Contributing Member</i>
T. M. Musto	A. Pridmore, <i>Contributing Member</i>

**Task Group on Repair by Carbon Fiber Composites  
(WG-NMRRR) (SG-RRR) (BPV XI)**

S. W. Choi, <i>Chair</i>	R. P. Ojdrovic
W. Bushika	J. E. O'Sullivan
D. Cimock	N. Otten
M. J. Constable	A. Pridmore
M. Elen	S. Rios
M. Golliet	J. Sealey
P. Krishnaswamy	R. Stakenborghs
M. Kuntz	D. J. Swaim
H. Lu	M. Tatkowski
L. Nadeau	M. F. Uddin
C. A. Nove	J. Wen

**Working Group on Welding and Special Repair Processes  
(SG-RRR) (BPV XI)**

J. G. Weicks, <i>Chair</i>	D. Jacobs
G. T. Olson, <i>Secretary</i>	M. Kris
D. Barborak	S. E. Marlette
K. Dietrich	S. L. McCracken
S. J. Findlan	L. A. Melder
R. C. Folley	J. E. O'Sullivan
M. L. Hall	A. Patel
J. Honcharik	

**Task Group on Temper Bead Welding  
(WG-W&SRP) (SG-RRR) (BPV XI)**

S. J. Findlan, <i>Chair</i>	H. Kobayashi
J. Tatman, <i>Secretary</i>	S. L. McCracken
D. Barborak	N. Mohr
D. Barton	G. T. Olson
R. C. Folley	J. E. O'Sullivan
J. Graham	A. Patel
M. L. Hall	J. G. Weicks
D. Jacobs	

**Task Group on Weld Overlay (WG-W&SRP) (SG-RRR) (BPV XI)**

S. L. McCracken, <i>Chair</i>	S. E. Marlette
S. Hunter, <i>Secretary</i>	S. K. Min
D. Barborak	G. T. Olson
D. Barton	A. Patel
S. J. Findlan	D. W. Sandusky
J. Graham	J. Tatman
M. L. Hall	J. G. Weicks
D. Jacobs	

**Subgroup on Water-Cooled Systems (BPV XI)**

M. J. Ferlisi, <i>Chair</i>	D. W. Lamond
J. Nygaard, <i>Secretary</i>	T. Nomura
S. T. Chesworth	S. A. Norman
J. Collins	M. A. Pyne
H. Q. Do	H. M. Stephens, Jr.
K. W. Hall	M. Weis
P. J. Hennessey	B. K. Welch
A. Keller	I. A. Anchondo-Lopez, <i>Alternate</i>
A. E. Keyser	Y.-K. Chung, <i>Contributing Member</i>
S. D. Kulat	

**Task Group on High Strength Nickel Alloys Issues (SG-WCS) (BPV XI)**

H. Malinkowski, <i>Chair</i>	H. Kobayashi
C. Waskey, <i>Secretary</i>	S. E. Marlette
T. Cinson	J. Robinson
J. Collins	D. Van Allen
O. Cruz	G. White
K. Dietrich	K. A. Whitney

**Working Group on Containment (SG-WCS) (BPV XI)**

M. J. Ferlisi, <i>Chair</i>	M. Sircar
S. Walden, <i>Secretary</i>	P. C. Smith
H. T. Hill	R. S. Spencer
S. Johnson	A. Staller
A. E. Keyser	J. Swan
P. Leininger	C. Tillotson
J. A. Munshi	G. Z. Wang
S. Richter	M. Weis

**Working Group on Inspection of Systems and Components  
(SG-WCS) (BPV XI)**

H. Q. Do, <i>Chair</i>	A. Keller
M. Weis, <i>Secretary</i>	E. E. Keyser
R. W. Blyde	S. D. Kulat
J. Collins	E. Lantz
M. J. Ferlisi	J. C. Nygaard
M. L. Garcia Heras	S. Orita
K. W. Hall	R. S. Spencer
E. Henry	M. Walter
J. Howard	A. W. Wilkens

**Working Group on Pressure Testing (SG-WCS) (BPV XI)**

S. A. Norman, <i>Chair</i>	S. Levitus
M. Moenssens, <i>Secretary</i>	R. A. Nettles
T. Anselmi	J. Swan
A. Knighton	K. Whitney
D. W. Lamond	

**Working Group on Risk-Informed Activities (SG-WCS) (BPV XI)**

M. A. Pyne, <i>Chair</i>	J. T. Jewell
S. T. Chesworth, <i>Secretary</i>	S. D. Kulat
G. Brouette	D. W. Lamond
R. Fougousse	E. Lantz
J. Hakii	P. J. O'Regan
K. W. Hall	N. A. Palm
M. J. Homiack	S. E. Woolf

**Working Group on General Requirements (BPV XI)**

D. Vetter, <i>Chair</i>	A. Mills
S. E. Woolf, <i>Secretary</i>	G. Ramaraj
T. L. Chan	T. N. Rezk
P. J. Hennessey	A. T. Roberts III
R. Hinkle	B. K. Welch
K. A. Kavanagh	B. Harris, <i>Alternate</i>

**Subgroup on Nonmandatory Appendices (BPV XII)**

T. A. Rogers, <i>Chair</i>	T. J. Rishel
S. Staniszewski, <i>Secretary</i>	R. C. Sallash
P. Chilukuri	D. G. Shelton
N. J. Paulick	Y. Doron, <i>Contributing Member</i>
M. Pitts	

**COMMITTEE ON TRANSPORT TANKS (BPV XII)**

N. J. Paulick, <i>Chair</i>	J. Roberts
M. D. Rana, <i>Vice Chair</i>	T. A. Rogers
J. Oh, <i>Staff Secretary</i>	R. C. Sallash
A. N. Antoniou	M. Shah
K. W. A. Cheng	S. Staniszewski
P. Chilukuri	A. P. Varghese
O. Mulet	R. Meyers, <i>Contributing Member</i>
M. Pitts	

**Executive Committee (BPV XII)**

M. D. Rana, <i>Chair</i>	M. Pitts
N. J. Paulick, <i>Vice Chair</i>	T. A. Rogers
J. Oh, <i>Staff Secretary</i>	S. Staniszewski
P. Chilukuri	

**Subgroup on Design and Materials (BPV XII)**

P. Chilukuri, <i>Chair</i>	A. P. Varghese
K. W. A. Cheng	K. Xu
S. L. McWilliams	D. K. Chandiramani, <i>Contributing Member</i>
N. J. Paulick	Y. Doron, <i>Contributing Member</i>
M. D. Rana	M. Pitts, <i>Contributing Member</i>
T. J. Rishel	D. G. Shelton, <i>Contributing Member</i>
T. A. Rogers	B. E. Spencer, <i>Contributing Member</i>
R. C. Sallash	J. Zheng, <i>Contributing Member</i>
M. Shah	
S. Staniszewski	

**Subgroup on Fabrication, Inspection, and Continued Service (BPV XII)**

M. Pitts, <i>Chair</i>	J. Roberts
P. Chilukuri, <i>Secretary</i>	R. C. Sallash
K. W. A. Cheng	S. Staniszewski
Y. Doron	K. Mansker, <i>Contributing Member</i>
M. Koprivnak	G. McRae, <i>Contributing Member</i>
O. Mulet	T. A. Rogers, <i>Contributing Member</i>
T. J. Rishel	

**Subgroup on General Requirements (BPV XII)**

S. Staniszewski, <i>Chair</i>	T. J. Rishel
A. N. Antoniou	R. C. Sallash
P. Chilukuri	Y. Doron, <i>Contributing Member</i>
J. L. Freiler	S. L. McWilliams, <i>Contributing Member</i>
O. Mulet	
B. F. Pittel	T. A. Rogers, <i>Contributing Member</i>
M. Pitts	D. G. Shelton, <i>Contributing Member</i>

**COMMITTEE ON OVERPRESSURE PROTECTION (BPV XIII)**

B. K. Nutter, <i>Chair</i>	J. F. Ball, <i>Contributing Member</i>
A. Donaldson, <i>Vice Chair</i>	R. W. Barnes, <i>Contributing Member</i>
C. E. Rodrigues, <i>Staff Secretary</i>	R. D. Danzy, <i>Contributing Member</i>
R. Antoniuk	J. Grace, <i>Contributing Member</i>
T. P. Beirne	S. F. Harrison, Jr., <i>Contributing Member</i>
Joey Burgess	A. Hassan, <i>Contributing Member</i>
D. B. DeMichael	P. K. Lam, <i>Contributing Member</i>
J. W. Dickson	M. Mengon, <i>Contributing Member</i>
B. Engman	J. Mize, <i>Contributing Member</i>
K. R. May	M. Mullavey, <i>Contributing Member</i>
D. Miller	J. Phillips, <i>Contributing Member</i>
T. Patel	S. Ruesenberg, <i>Contributing Member</i>
B. F. Pittel	
T. R. Tarbay	K. Shores, <i>Contributing Member</i>
D. E. Tompkins	D. E. Tezzo, <i>Contributing Member</i>
J. A. West	A. Wilson, <i>Contributing Member</i>
M. Edwards, <i>Alternate</i>	

**Executive Committee (BPV XIII)**

A. Donaldson, <i>Chair</i>	K. R. May
B. K. Nutter, <i>Vice Chair</i>	T. Patel
C. E. Rodrigues, <i>Staff Secretary</i>	B. F. Pittel
T. Beirne	

**Subgroup on Design and Materials (BPV XIII)**

T. Patel, <i>Chair</i>	D. Miller
V. Kalyanasundaram, <i>Vice Chair</i>	T. R. Tarbay
A. Williams, <i>Secretary</i>	J. A. West
T. K. Acharya	D. J. Azukas, <i>Contributing Member</i>
W. E. Chapin	R. D. Danzy, <i>Contributing Member</i>
B. Joergensen	M. Mullavey, <i>Contributing Member</i>
R. Krithivasan	G. Ramirez, <i>Contributing Member</i>
J. Latshaw	S. Zalar, <i>Contributing Member</i>

**Subgroup on General Requirements (BPV XIII)**

B. F. Pittel, <i>Chair</i>	D. E. Tezzo
J. Grace, <i>Secretary</i>	D. E. Tompkins
R. Antoniuk	J. F. White
J. F. Ball	M. Edwards, <i>Alternate</i>
Joey Burgess	P. Chavdarov, <i>Contributing Member</i>
John Burgess	J. L. Freiler, <i>Contributing Member</i>
D. B. DeMichael	G. D. Goodson, <i>Contributing Member</i>
A. Donaldson	
S. T. French	B. Joergensen, <i>Contributing Member</i>
J. Horne	P. K. Lam, <i>Contributing Member</i>
R. Klimas, Jr.	E. Pearson, <i>Contributing Member</i>
Z. E. Kumana	J. Phillips, <i>Contributing Member</i>
D. Mainiero-Cessna	S. Ruesenberg, <i>Contributing Member</i>
K. R. May	
J. Mize	M. Mullavey
L. Moedinger	A. Peck
M. Mullavey	
A. Peck	S. Zalar, <i>Contributing Member</i>

**Subgroup on Nuclear (BPV XIII)**

K. R. May, <i>Chair</i>	S. Jones
J. F. Ball, <i>Vice Chair</i>	D. Miller
R. Krithivasan, <i>Secretary</i>	T. Patel
M. Brown	B. J. Yonsky
J. W. Dickson	J. Yu, <i>Alternate</i>
N. Hansing	S. T. French, <i>Contributing Member</i>

**Subgroup on Testing (BPV XIII)**

T. P. Beirne, <i>Chair</i>	R. Lack, <i>Alternate</i>
J. W. Dickson, <i>Vice Chair</i>	M. Brown, <i>Contributing Member</i>
C. Hofmeister, <i>Secretary</i>	J. Mize, <i>Contributing Member</i>
V. Chicola III	M. Mullavey, <i>Contributing Member</i>
B. Engman	S. Ruesenberg, <i>Contributing Member</i>
R. J. Garnett	C. Sharpe, <i>Contributing Member</i>
R. Houk	K. Shores, <i>Contributing Member</i>
N. Jump	A. Strecker, <i>Contributing Member</i>
B. K. Nutter	A. Wilson, <i>Contributing Member</i>
J. R. Thomas, Jr.	
C. Bauer, <i>Alternate</i>	

**COMMITTEE ON BOILER AND PRESSURE VESSEL CONFORMITY ASSESSMENT (CBPVCA)**

L. E. McDonald, <i>Chair</i>	P. Williams
E. Whittle, <i>Vice Chair</i>	T. P. Beirne, <i>Alternate</i>
G. Moino, <i>Staff Secretary</i>	N. Caputo, <i>Alternate</i>
P. Chavdarov	J. M. Downs, <i>Alternate</i>
J. P. Chicoine	Y.-S. Kim, <i>Alternate</i>
A. Donaldson	B. L. Krasiun, <i>Alternate</i>
T. E. Hansen	K. Roewe, <i>Alternate</i>
W. Hibdon	B. C. Turczynski, <i>Alternate</i>
M. Prefumo	R. Underwood, <i>Alternate</i>
R. Rockwood	J. Yu, <i>Alternate</i>
G. Scribner	D. Cheetham, <i>Contributing Member</i>
D. E. Tuttle	A. J. Spencer, <i>Honorary Member</i>
R. V. Wielgoszinski	

**COMMITTEE ON NUCLEAR CERTIFICATION (CNC)**

R. R. Stevenson, <i>Chair</i>	T. N. Rezk
M. A. Lockwood, <i>Vice Chair</i>	E. A. Whittle
H. Ruan, <i>Secretary</i>	T. Aldo, <i>Alternate</i>
S. Andrews	M. Blankinship, <i>Alternate</i>
A. Appleton	G. Brouette, <i>Alternate</i>
G. Claffey	Y. Diaz-Castillo, <i>Alternate</i>
N. DeSantis	P. D. Edwards, <i>Alternate</i>
C. Dinic	R. Hinkle, <i>Alternate</i>
G. Gobbi	K. M. Hottle, <i>Alternate</i>
J. Grimm	J. Kiefer, <i>Alternate</i>
J. W. Highlands	S. J. Montano, <i>Alternate</i>
K. A. Kavanagh	R. Spuhl, <i>Alternate</i>
J. C. Krane	M. Wilson, <i>Alternate</i>
B. McGlone	S. Yang, <i>Alternate</i>
I. Olson	M. Burke, <i>Contributing Member</i>
E. L. Pleins	S. F. Harrison, Jr., <i>Contributing Member</i>
L. Ponce	
T. E. Quaka	

# CORRESPONDENCE WITH THE COMMITTEE

## General

ASME codes and standards are developed and maintained by committees with the intent to represent the consensus of concerned interests. Users of ASME codes and standards may correspond with the committees to propose revisions or cases, report errata, or request interpretations. Correspondence for this Section of the ASME Boiler and Pressure Vessel Code (BPVC) should be sent to the staff secretary noted on the Section's committee web page, accessible at <https://go.asme.org/CSCcommittees>.

NOTE: See ASME BPVC Section II, Part D for guidelines on requesting approval of new materials. See Section II, Part C for guidelines on requesting approval of new welding and brazing materials ("consumables").

## Revisions and Errata

The committee processes revisions to this Code on a continuous basis to incorporate changes that appear necessary or desirable as demonstrated by the experience gained from the application of the Code. Approved revisions will be published in the next edition of the Code.

In addition, the committee may post errata and Special Notices at <http://go.asme.org/BPVCerrata>. Errata and Special Notices become effective on the date posted. Users can register on the committee web page to receive email notifications of posted errata and Special Notices.

This Code is always open for comment, and the committee welcomes proposals for revisions. Such proposals should be as specific as possible, citing the paragraph number, the proposed wording, and a detailed description of the reasons for the proposal, including any pertinent background information and supporting documentation.

## Cases

- (a) The most common applications for cases are
- (1) to permit early implementation of a revision based on an urgent need
  - (2) to provide alternative requirements
  - (3) to allow users to gain experience with alternative or potential additional requirements prior to incorporation directly into the Code
  - (4) to permit use of a new material or process
- (b) Users are cautioned that not all jurisdictions or owners automatically accept cases. Cases are not to be considered as approving, recommending, certifying, or endorsing any proprietary or specific design, or as limiting in any way the freedom of manufacturers, constructors, or owners to choose any method of design or any form of construction that conforms to the Code.
- (c) The committee will consider proposed cases concerning the following topics only:
- (1) equipment to be marked with the ASME Single Certification Mark, or
  - (2) equipment to be constructed as a repair/replacement activity under the requirements of Section XI
- (d) A proposed case shall be written as a question and reply in the same format as existing cases. The proposal shall also include the following information:
- (1) a statement of need and background information
  - (2) the urgency of the case (e.g., the case concerns a project that is underway or imminent)
  - (3) the Code Section and the paragraph, figure, or table number to which the proposed case applies
  - (4) the editions of the Code to which the proposed case applies
- (e) A case is effective for use when the public review process has been completed and it is approved by the cognizant supervisory board. Cases that have been approved will appear in the next edition or supplement of the Code Cases books, "Boilers and Pressure Vessels" or "Nuclear Components." Each Code Cases book is updated with seven Supplements. Supplements will be sent or made available automatically to the purchasers of the Code Cases books until the next edition of the Code. Annulments of Code Cases become effective six months after the first announcement of the annulment in a Code Case Supplement or Edition of the appropriate Code Case book. The status of any case is available at <http://go.asme.org/BPVCCDatabase>. An index of the complete list of Boiler and Pressure Vessel Code Cases and Nuclear Code Cases is available at <http://go.asme.org/BPVCC>.

## Interpretations

(a) Interpretations clarify existing Code requirements and are written as a question and reply. Interpretations do not introduce new requirements. If a revision to resolve conflicting or incorrect wording is required to support the interpretation, the committee will issue an intent interpretation in parallel with a revision to the Code.

(b) Upon request, the committee will render an interpretation of any requirement of the Code. An interpretation can be rendered only in response to a request submitted through the online Inquiry Submittal Form at <http://go.asme.org/InterpretationRequest>. Upon submitting the form, the inquirer will receive an automatic email confirming receipt.

(c) ASME does not act as a consultant for specific engineering problems or for the general application or understanding of the Code requirements. If, based on the information submitted, it is the opinion of the committee that the inquirer should seek assistance, the request will be returned with the recommendation that such assistance be obtained. Inquirers may track the status of their requests at <http://go.asme.org/Interpretations>.

(d) ASME procedures provide for reconsideration of any interpretation when or if additional information that might affect an interpretation is available. Further, persons aggrieved by an interpretation may appeal to the cognizant ASME committee or subcommittee. ASME does not “approve,” “certify,” “rate,” or “endorse” any item, construction, proprietary device, or activity.

(e) Interpretations are published in the ASME Interpretations Database at <http://go.asme.org/Interpretations> as they are issued.

## Committee Meetings

The ASME BPVC committees regularly hold meetings that are open to the public. Persons wishing to attend any meeting should contact the secretary of the applicable committee. Information on future committee meetings can be found at <http://go.asme.org/BCW>.

## PREFACE

(25)

The American Society of Mechanical Engineers (ASME) and the American Society for Testing and Materials (ASTM) have cooperated for more than fifty years in the preparation of material specifications adequate for safety in the field of pressure equipment for ferrous and nonferrous materials, contained in Section II (Part A — Ferrous and Part B — Nonferrous) of the ASME Boiler and Pressure Vessel Code.

The evolution of this cooperative effort is contained in Professor A. M. Greene's "History of the ASME Boiler Code," which was published as a series of articles in *Mechanical Engineering* from July 1952 through August 1953 and is now available from ASME in a special bound edition. The following quotations from this history, which was based upon the minutes of the ASME Boiler and Pressure Vessel Committee, will help focus on the cooperative nature of the specifications found in Section II, Material Specifications.

*"General discussion of material specifications comprising Paragraphs 1 to 112 of Part 2 and the advisability of having them agree with ASTM specifications," (1914).*

*"ASME Subcommittee appointed to confer with ASTM," (1916).*

*"Because of this cooperation the specifications of the 1918 Edition of the ASME Boiler Code were more nearly in agreement with ASTM specifications. In the 1924 Edition of the Code, 10 specifications were in complete agreement with ASTM specifications, 4 in substantial agreement and 2 covered materials for which ASTM had no corresponding specifications."*

*"In Section II, Material Specifications, the paragraphs were given new numbers beginning with S-1 and extending to S-213," (1925).*

*"Section II was brought into agreement with changes made in the latest ASTM specifications since 1921," (1932).*

*"The Subcommittee on Material Specifications arranged for the introduction of the revisions of many of the specifications so that they would agree with the latest form of the earlier ASTM specifications...," (1935).*

From the preceding, it is evident that many of the material specifications were prepared by the Boiler and Pressure Vessel Code Committees, then subsequently, by cooperative action, modified and identified as ASTM specifications. Section II, Parts A and B, currently contain many material specifications that are identical with the corresponding ASTM specifications and some that have been modified for Code usage. Many of these specifications are published in dual format. That is, they contain both U.S. Customary units and SI units. The metrication protocols followed in the specifications are those adopted by ASTM, and are usually to the rules of IEEE/ASTM SI 10-1997, Standard for the Use of the International System of Units (SI): The Modern Metric System.

In 1969, the American Welding Society began publication of specifications for welding rods, electrodes, and filler metals, hitherto issued by ASTM. The Boiler and Pressure Vessel Committee has recognized this new arrangement, and is now working with AWS on these specifications. Section II, Part C, contains the welding material specifications approved for Code use.

In 1992, the ASME Board of Pressure Technology Codes and Standards endorsed the use of non-ASTM material for Boiler and Pressure Vessel Code applications. It is the intent to follow the procedures and practices currently in use to implement the adoption of non-ASTM materials.

The specifications prepared and copyrighted by ASTM, AWS, and other originating organizations are reproduced in the Code with the permission of the respective Society. The ASME Boiler and Pressure Vessel Committee has given careful consideration to each new and revised specification, and has made such changes as they deemed necessary to make the specification adaptable for Code usage. In addition, ASME has furnished ASTM with the basic requirements that should govern many proposed new specifications. Joint action will continue an effort to make the ASTM, AWS, and ASME specifications identical.

To assure that there will be a clear understanding on the part of the users of Section II, ASME publishes both the identical specifications and those amended for Code usage every 2 years.

The ASME Boiler and Pressure Vessel Code has been adopted into law by 50 states and many municipalities in the United States and by all of the Canadian provinces.

# SPECIFICATIONS LISTED BY MATERIALS

(25)

## Aluminum and Aluminum Alloys

SB-26/SB-26M	Specification for Aluminum-Alloy Sand Castings .....	3
SB-108/SB-108M	Specification for Aluminum-Alloy Permanent Mold Castings .....	63
SB-209/SB-209M	Specification for Aluminum and Aluminum-Alloy Sheet and Plate .....	271
SB-210	Specification for Aluminum and Aluminum-Alloy Drawn Seamless Tubes .....	315
SB-211/SB-211M	Specification for Aluminum and Aluminum-Alloy Rolled or Cold-Finished Bar, Rod, and Wire .....	327
SB-221	Specification for Aluminum and Aluminum-Alloy Extruded Bars, Rods, Wire, Profiles, and Tubes .....	341
SB-221M	Specification for Aluminum and Aluminum-Alloy Extruded Bars, Rods, Wire, Profiles, and Tubes (Metric) .....	359
SB-234	Specification for Aluminum and Aluminum-Alloy Drawn Seamless Tubes for Condensers and Heat Exchangers .....	379
SB-241/SB-241M	Specification for Aluminum and Aluminum-Alloy Seamless Pipe and Seamless Extruded Tube .....	387
SB-247	Specification for Aluminum and Aluminum-Alloy Die Forgings, Hand Forgings, and Rolled Ring Forgings .....	409
SB-308/SB-308M	Specification for Aluminum-Alloy 6061-T6 Standard Structural Profiles .....	505
SB-548	Test Method for Ultrasonic Inspection of Aluminum-Alloy Plate for Pressure Vessels .....	819
SB-666/SB-666M	Practice for Identification Marking of Aluminum and Magnesium Products .....	975
SB-928/SB-928M	Specification for High Magnesium Aluminum-Alloy Sheet and Plate for Marine Service and Similar Environments .....	1169
SB/EN 1706	Aluminum and Aluminum Alloys — Castings — Chemical Composition and Mechanical Properties .....	1243

## Cobalt Alloys

SB-815	Specification for Cobalt-Chromium-Nickel-Molybdenum-Tungsten Alloy (UNS R31233) Rod	1099
SB-818	Specification for Cobalt-Chromium-Nickel-Molybdenum-Tungsten Alloy (UNS R31233) Plate, Sheet, and Strip .....	1103

## Copper Alloy Castings

SB-61	Specification for Steam or Valve Bronze Castings .....	33
SB-62	Specification for Composition Bronze or Ounce Metal Castings .....	37
SB-148	Specification for Aluminum-Bronze Sand Castings .....	115
SB-271/SB-271M	Specification for Copper-Base Alloy Centrifugal Castings .....	479
SB-369	Specification for Copper-Nickel Alloy Castings .....	589
SB-505/SB-505M	Specification for Copper Alloy Continuous Castings .....	745
SB-584	Specification for Copper Alloy Sand Castings for General Applications .....	887
SB-824	Specification for General Requirements for Copper Alloy Castings .....	1107

## Copper and Copper Alloy Pipe and Tubes

SB-42	Specification for Seamless Copper Pipe, Standard Sizes .....	17
SB-43	Specification for Seamless Red Brass Pipe, Standard Sizes .....	25
SB-75/SB-75M	Specification for Seamless Copper Tube .....	41
SB-111/SB-111M	Specification for Copper and Copper-Alloy Seamless Condenser Tubes and Ferrule Stock ..	81
SB-135/SB-135M	Specification for Seamless Brass Tube .....	105

SB-251/SB-251M	Specification for General Requirements for Wrought Seamless Copper and Copper-Alloy Tube .....	455
SB-315	Specification for Seamless Copper Alloy Pipe and Tube .....	511
SB-359/SB-359M	Specification for Copper and Copper-Alloy Seamless Condenser and Heat Exchanger Tubes with Integral Fins .....	553
SB-395/SB-395M	Specification for U-Bend Seamless Copper and Copper Alloy Heat Exchanger and Condenser Tubes .....	605
SB-466/SB-466M	Specification for Seamless Copper-Nickel Pipe and Tube .....	701
SB-467	Specification for Welded Copper-Nickel Pipe .....	709
SB-543/SB-543M	Specification for Welded Copper and Copper-Alloy Heat Exchanger Tube .....	805
SB-706	Specification for Seamless Copper Alloy (UNS NO. C69100) Pipe and Tube .....	1049
SB-956	Specification for Welded Copper and Copper-Alloy Condenser and Heat Exchanger Tubes with Integral Fins .....	1183

**Copper and Copper Alloy Plate, Sheet, Strip, and Rolled Bar**

SB-96/SB-96M	Specification for Copper-Silicon Alloy Plate, Sheet, Strip, and Rolled Bar for General Purposes and Pressure Vessels .....	51
SB-152/SB-152M	Specification for Copper Sheet, Strip, Plate, and Rolled Bar .....	137
SB-169/SB-169M	Specification for Aluminum Bronze Sheet, Strip, and Rolled Bar .....	247
SB-171/SB-171M	Specification for Copper-Alloy Plate and Sheet for Pressure Vessels, Condensers, and Heat Exchangers .....	253
SB-248	Specification for General Requirements for Wrought Copper and Copper-Alloy Plate, Sheet, Strip, and Rolled Bar .....	427
SB-283/SB-283M	Specification for Copper and Copper-Alloy Die Forgings (Hot-Pressed) .....	487

**Copper and Copper Alloy Rod, Bar, and Shapes**

SB-98/SB-98M	Specification for Copper-Silicon Alloy Rod, Bar and Shapes .....	57
SB-150/SB-150M	Specification for Aluminum Bronze Rod, Bar, and Shapes .....	123
SB-151/SB-151M	Specification for Copper-Nickel-Zinc Alloy (Nickel Silver) and Copper-Nickel Rod and Bar .....	131
SB-187/SB-187M	Specification for Copper, Bus Bar, Rod, and Shapes and General Purpose Rod, Bar, and Shapes .....	261
SB-249/SB-249M	Specification for General Requirements for Wrought Copper and Copper-Alloy Rod, Bar, Shapes, and Forgings .....	441

**Nickel Alloy Castings**

SA-494/SA-494M	Specification for Castings, Nickel and Nickel Alloy .....	737
----------------	---	-----

**Nickel and Nickel Alloy Fittings**

SB-366/SB-366M	Specification for Factory-Made Wrought Nickel and Nickel Alloy Fittings .....	571
SB-834	Specification for Pressure Consolidated Powder Metallurgy Iron-Nickel- Chromium-Molybdenum (UNS N08367), Nickel-Chromium- Molybdenum-Columbium (Nb) (UNS N06625), Nickel- Chromium-Iron Alloys (UNS N06600 and N06690), and Nickel-Chromium-Iron-Columbium-Molybdenum (UNS N07718) Alloy Pipe Flanges, Fittings, Valves, and Parts .....	1123

**Nickel and Nickel Alloy Pipe and Tubes**

SB-161	Specification for Nickel Seamless Pipe and Tube .....	155
SB-163	Specification for Seamless Nickel and Nickel Alloy Condenser and Heat-Exchanger Tubes .....	177
SB-165	Specification for Nickel-Copper Alloy Seamless Pipe and Tube .....	205
SB-167	Specification For Nickel-Chromium-Aluminum Alloys (UNS N06699), Nickel-Chromium-Iron Alloys (UNS N06600, N06601, N06603, N06690, N06693, N06025, N06045, and N06696), and Nickel-Chromium-Cobalt-Molybdenum Alloy (UNS N06617), Nickel-Iron-Chromium-Tungsten Alloy (UNS N06674), and Nickel-Chromium-Molybdenum-Copper Alloy (UNS N06235) Seamless Pipe and Tube .....	223

SB-407	Specification for Nickel-Iron-Chromium Alloy Seamless Pipe and Tube .....	619
SB-423	Specification for Nickel-Iron-Chromium-Molybdenum-Copper Alloy (UNS N08825 and N08221) Seamless Pipe and Tube .....	637
SB-444	Specification for Nickel-Chromium-Molybdenum-Columbium Alloys (UNS N06625 and UNS N06852) and Nickel-Chromium-Molybdenum-Silicon Alloy (UNS N06219) Pipe and Tube .....	677
SB-462	Specification for Forged or Rolled Nickel Alloy Pipe Flanges, Forged Fittings, and Valves and Parts for Corrosive High-Temperature Service .....	687
SB-464	Specification for Welded UNS N08020, N08024, and N08026 Alloy Pipe .....	697
SB-468	Specification for Welded UNS N08020, N08024, and N08026 Alloy Tubes .....	719
SB-514	Specification for Welded Nickel-Iron-Chromium Alloy Pipe .....	767
SB-515	Specification for Welded UNS N08120, UNS N08800, UNS N08810, and UNS N08811 Alloy Tubes .....	771
SB-516	Specification for Welded Nickel-Chromium-Aluminum Alloy (UNS N06699) and Nickel-Chromium-Iron Alloy (UNS N06600, UNS N06601, UNS N06603, UNS N06025, UNS N06045, UNS N06690, AND UNS N06693) Tubes .....	775
SB-517	Specification for Welded Nickel-Chromium-Iron Alloy (UNS N06600, UNS N06603, UNS N06025, and UNS N06045) Pipe .....	779
SB-535	Specification for Nickel-Iron-Chromium-Silicon Alloys (UNS N08330 and N08332) Seamless Pipe and Tube .....	789
SB-619/SB-619M	Specification for Welded Nickel and Nickel-Cobalt Alloy Pipe .....	911
SB-622	Specification for Seamless Nickel and Nickel-Cobalt Alloy Pipe and Tube .....	927
SB-626	Specification for Welded Nickel and Nickel-Cobalt Alloy Tube .....	941
SB-668	Specification for UNS N08028 Seamless Tubes .....	983
SB-673	Specification for UNS N08925, UNS N08354, and UNS N08926 Welded Pipe .....	995
SB-674	Specification for UNS N08925, UNS N08354, and UNS N08926 Welded Tube .....	999
SB-675	Specification for UNS N08367 Welded Pipe .....	1003
SB-676	Standard Specification for UNS N08367 Welded Tube .....	1007
SB-677	Specification for Nickel-Iron-Chromium-Molybdenum and Iron-Nickel-Chromium-Molybdenum-Copper Seamless Pipe and Tube .....	1011
SB-690	Specification for Iron-Nickel-Chromium-Molybdenum Alloys (UNS N08366 and UNS N08367) Seamless Pipe and Tube .....	1025
SB-704	Specification for Welded UNS N06625, UNS N06219, and UNS N08825 Alloy Tubes .....	1041
SB-705	Specification for Nickel-Alloy (UNS N06625, N06219 and N08825) Welded Pipe .....	1045
SB-710	Specification for Nickel-Iron-Chromium-Silicon Alloy Welded Pipe .....	1063
SB-729	Specification for Seamless Nickel-Iron-Chromium-Molybdenum-Copper Nickel Alloy Pipe and Tube .....	1067
SB-751	Specification for General Requirements for Nickel and Nickel-Alloy Welded Tube .....	1071
SB-775	Specification for General Requirements for Nickel and Nickel-Alloy Welded Pipe .....	1085
SB-804	Specification for UNS N08367 and UNS N08926 Welded Pipe .....	1091
SB-829	Specification for General Requirements for Nickel and Nickel Alloys Seamless Pipe and Tube .....	1115

**Nickel and Nickel Alloy Plate, Sheet, and Strip**

SB-127	Specification for Nickel-Copper Alloy (UNS N04400) Plate, Sheet, and Strip .....	95
SB-162	Specification for Nickel Plate, Sheet, and Strip .....	161
SB-168	Specification For Nickel-Chromium-Aluminum Alloys (UNS N06699), Nickel-Chromium-Iron Alloys (UNS N06600, N06601, N06603, N06690, N06693, N06025, N06045, and N06696), Nickel-Chromium-Cobalt-Molybdenum Alloy (UNS N06617), Nickel-Iron-Chromium-Tungsten Alloy (UNS N06674), and Nickel-Chromium-Molybdenum-Copper Alloy (UNS N06235) Plate, Sheet, and Strip .....	233
SB-333	Specification for Nickel-Molybdenum Alloy Plate, Sheet, and Strip .....	523
SB-409	Specification for Nickel-Iron-Chromium Alloy Plate, Sheet, and Strip .....	631
SB-424	Specification for Ni-Fe-Cr-Mo-Cu Alloy (UNS N08825, UNS N08221, and UNS N06845) Plate, Sheet, and Strip .....	643
SB-434	Specification for Nickel-Molybdenum-Chromium-Iron Alloys (UNS N10003, UNS N10242) Plate, Sheet, and Strip .....	657

SB-435	Specification for UNS N06002, UNS N06230, UNS N12160, and UNS R30556 Plate, Sheet, and Strip .....	661
SB-443	Specification for Nickel-Chromium-Molybdenum-Columbium Alloy (UNS N06625) and Nickel-Chromium-Molybdenum-Silicon Alloy (UNS N06219) Plate, Sheet, and Strip ....	665
SB-463	Specification for UNS N08020 Alloy Plate, Sheet, and Strip .....	693
SB-536	Specification for Nickel-Iron-Chromium-Silicon Alloys (UNS N08330 and N08332) Plate, Sheet, and Strip .....	793
SB-575	Specification for Low-Carbon Nickel-Chromium-Molybdenum, Low-Carbon Nickel-Chromium-Molybdenum-Copper, Low-Carbon Nickel-Chromium-Molybdenum-Tantalum, Low-Carbon Nickel-Chromium-Molybdenum-Tungsten, and Low-Carbon Nickel-Molybdenum-Chromium Alloy Plate, Sheet, and Strip .....	871
SB-582	Specification for Nickel-Chromium-Iron-Molybdenum-Copper Alloy Plate, Sheet, and Strip .....	883
SB-599	Specification for Nickel-Iron-Chromium-Molybdenum-Columbium Stabilized Alloy (UNS N08700) Plate, Sheet, and Strip .....	897
SB-620	Specification for Nickel-Iron-Chromium-Molybdenum Alloy (UNS N08320) Plate, Sheet, and Strip .....	919
SB-625	Specification for UNS N08925, UNS N08031, UNS N08034, UNS N08932, UNS N08926, UNS N08354, UNS N08830, and UNS R20033 Plate, Sheet, and Strip .....	935
SB-688	Specification for Chromium-Nickel-Molybdenum-Iron (UNS N08366 and UNS N08367) Plate, Sheet, and Strip .....	1015
SB-709	Specification for Iron-Nickel-Chromium-Molybdenum Alloy (UNS N08028) Plate, Sheet, and Strip .....	1057
SB-906	Specification for General Requirements for Flat-Rolled Nickel and Nickel Alloys Plate, Sheet, and Strip .....	1151

**Nickel and Nickel Alloy Rod, Bar, and Wire**

SB-160	Specification for Nickel Rod and Bar .....	145
SB-164	Specification for Nickel-Copper Alloy Rod, Bar, and Wire .....	191
SB-166	Specification for Nickel-Chromium-Aluminum Alloy, Nickel-Chromium-Iron Alloys, Nickel-Chromium-Cobalt-Molybdenum Alloy, Nickel-Iron-Chromium-Tungsten Alloy, and Nickel-Chromium-Molybdenum-Copper Alloy, Rod, Bar, and Wire .....	213
SB-335	Specification for Nickel-Molybdenum Alloy Rod .....	527
SB-408	Specification for Nickel-Iron-Chromium Alloy Rod and Bar .....	625
SB-425	Specification for Ni-Fe-Cr-Mo-Cu Alloy (UNS N08825 and UNS N08221) Rod and Bar ....	649
SB-446	Specification for Nickel-Chromium-Molybdenum-Columbium Alloy (UNS N06625), Nickel-Chromium-Molybdenum-Silicon Alloy (UNS N06219), and Nickel-Chromium-Molybdenum-Tungsten Alloy (UNS N06650) Rod and Bar .....	681
SB-473	Specification for UNS N08020, UNS N08024, and UNS N08026 Nickel Alloy Bar and Wire .....	723
SB-511	Specification for Nickel-Iron-Chromium-Silicon Alloy Bars and Shapes .....	757
SB-564	Specification for Nickel Alloy Forgings .....	843
SB-572	Specification for UNS N06002, UNS N06230, UNS N12160, and UNS R30556 Rod .....	855
SB-573	Specification for Nickel-Molybdenum-Chromium-Iron Alloys (UNS N10003, N10242) Rod .....	861
SB-574	Specification for Low-Carbon Nickel-Chromium-Molybdenum, Low-Carbon Nickel-Molybdenum-Chromium, Low-Carbon Nickel-Molybdenum-Chromium-Tantalum, Low-Carbon Nickel-Chromium-Molybdenum-Copper, and Low-Carbon Nickel-Chromium-Molybdenum-Tungsten Alloy Rod .....	865
SB-581	Specification for Nickel-Chromium-Iron-Molybdenum-Copper Alloy Rod .....	877
SB-621	Specification for Nickel-Iron-Chromium-Molybdenum Alloy (UNS N08320) Rod .....	923
SB-637	Specification for Precipitation-Hardening and Cold Worked Nickel Alloy Bars, Forgings, and Forging Stock for Moderate or High-Temperature Service .....	947
SB-649	Specification for Ni-Fe-Cr-Mo-Cu-N Low-Carbon Alloys (UNS N08925, UNS N08031, UNS N08034, UNS N08354, and UNS N08926), and Cr-Ni-Fe-N Low-Carbon Alloy (UNS R20033) Bar and Wire, and Ni-Cr-Fe-Mo-N Alloy (UNS N08936) Wire .....	955
SB-672	Specification for Nickel-Iron-Chromium-Molybdenum-Columbium Stabilized Alloy (UNS N08700) Bar and Wire .....	987

SB-691	Specification for Iron-Nickel-Chromium-Molybdenum Alloys (UNS N08366 and UNS N08367) Rod, Bar, and Wire .....	1033
--------	---	------

**Other**

SF-467	Specification for Nonferrous Nuts for General Use .....	1195
SF-467M	Specification for Nonferrous Nuts for General Use [Metric] .....	1205
SF-468	Specification for Nonferrous Bolts, Hex Cap Screws, Socket Head Cap Screws, and Studs for General Use .....	1215
SF-468M	Specification for Nonferrous Bolts, Hex Cap Screws, and Studs for General Use [Metric] ..	1231

**Titanium and Titanium Alloys**

SB-265	Specification for Titanium and Titanium Alloy Strip, Sheet, and Plate .....	465
SB-338	Specification for Seamless and Welded Titanium and Titanium Alloy Tubes for Condensers and Heat Exchangers .....	533
SB-348/SB-348M	Specification for Titanium and Titanium Alloy Bars and Billets .....	543
SB-363	Specification for Seamless and Welded Unalloyed Titanium and Titanium Alloy Welding Fittings .....	565
SB-367	Specification for Titanium and Titanium Alloy Castings .....	581
SB-381	Specification for Titanium and Titanium Alloy Forgings .....	595
SB-861	Specification for Titanium and Titanium Alloy Seamless Pipe .....	1129
SB-862	Specification for Titanium and Titanium Alloy Welded Pipe .....	1139

**Zirconium and Zirconium Alloys**

SB-493/SB-493M	Specification for Zirconium and Zirconium Alloy Forgings .....	733
SB-523/SB-523M	Specification for Seamless and Welded Zirconium and Zirconium Alloy Tubes .....	783
SB-550/SB-550M	Specification for Zirconium and Zirconium Alloy Bar and Wire .....	825
SB-551/SB-551M	Specification for Zirconium and Zirconium Alloy Strip, Sheet, and Plate .....	831
SB-653/SB-653M	Specification for Seamless and Welded Zirconium and Zirconium Alloy Welding Fittings ..	965
SB-658/SB-658M	Specification for Seamless and Welded Zirconium and Zirconium Alloy Pipe .....	969
SB-752/SB-752M	Specification for Castings, Zirconium-Base, Corrosion Resistant, for General Application ..	1079

ASMENORMDOC.COM : Click to view the full PDF of ASME BPVC:IB (ASME BPVC Section II Part B) 2025

## SPECIFICATION REMOVAL

From time to time, it becomes necessary to remove specifications from this Part of Section II. This occurs because the sponsoring society (e.g., ASTM, AWS, CEN) has notified ASME that the specification has either been replaced with another specification, or that there is no known use and production of a material. Removal of a specification from this Section also results in concurrent removal of the same specification from Section IX and from all of the ASME Boiler and Pressure Vessel Construction Codes that reference the material. This action effectively prohibits further use of the material in ASME Boiler and Pressure Vessel construction.

The following specifications will be dropped from this Section in the next Edition, unless information concerning current production and use of the material is received before December 1 of this year:

None

If you are currently using and purchasing new material to this specification for ASME Boiler and Pressure Vessel Code construction, and if discontinuance of this specification would present a hardship, please notify the Secretary of the ASME Boiler and Pressure Vessel Committee, at the address shown below:

Secretary  
ASME Boiler and Pressure Vessel Committee  
Two Park Avenue  
New York, NY 10016-5990

## SUMMARY OF CHANGES

In this 2025 edition, the “ASTM Personnel” page has been deleted from the front matter. In addition, specifications originating with ASTM that are new or revised in this 2025 edition are formatted differently than those retained from the 2023 and earlier editions. The document following the cover sheet of each new or revised specification is the unedited ASTM specification. The ASME title for the specification and any ASME-approved exceptions to the ASTM specification are shown only on the cover sheet. Specifications affected by the new format are listed in the Summary of Changes.

Changes listed below are identified on the pages by a margin note, **(25)**, placed next to the affected area.

<i>Page</i>	<i>Location</i>	<i>Change</i>
ix	List of Sections	Title of Section XI, Division 1 revised
x	Foreword	Third, fourth, seventh, tenth, and eleventh paragraphs editorially revised
xiii	Personnel	Updated
xxxix	Specifications Listed by Materials	Updated
1	Statement of Policy on the Use of ASME Material Specifications	Revised
33	SB-61	Revised in its entirety
37	SB-62	Revised in its entirety
223	SB-167	Title on cover sheet corrected by errata
233	SB-168	Title on cover sheet corrected by errata
271	SB-209/SB-209M	Revised in its entirety
341	SB-221	Revised in its entirety
359	SB-221M	Added
387	SB-241/SB-241M	Revised in its entirety
479	SB-271/SB-271M	Revised in its entirety
487	SB-283/SB-283M	Revised in its entirety
553	SB-359/SB-359M	Revised in its entirety
605	SB-395/SB-395M	Revised in its entirety
709	SB-467	Revised in its entirety
745	SB-505/SB-505M	Revised in its entirety
843	SB-564	Revised in its entirety
887	SB-584	Revised in its entirety
935	SB-625	Added section 6 and renumbered subsequent paragraphs
955	SB-649	(1) Note 1 revised (2) Para. 5.3 added

<i>Page</i>	<i>Location</i>	<i>Change</i>
1011	SB-677	Para. 6.1 revised
1246	Mandatory Appendix II	Revised in its entirety
1257	Mandatory Appendix IV	Revised

ASMENORMDOC.COM : Click to view the full PDF of ASME BPVC.II.B (ASME BPVC Section II part B) 2025

## CROSS-REFERENCING IN THE ASME BPVC

Paragraphs within the ASME BPVC may include subparagraph breakdowns, i.e., nested lists. The following is a guide to the designation and cross-referencing of subparagraph breakdowns:

*(a) Hierarchy of Subparagraph Breakdowns*

- (1) First-level breakdowns are designated as (a), (b), (c), etc.
- (2) Second-level breakdowns are designated as (1), (2), (3), etc.
- (3) Third-level breakdowns are designated as (-a), (-b), (-c), etc.
- (4) Fourth-level breakdowns are designated as (-1), (-2), (-3), etc.
- (5) Fifth-level breakdowns are designated as (+a), (+b), (+c), etc.
- (6) Sixth-level breakdowns are designated as (+1), (+2), etc.

*(b) Cross-References to Subparagraph Breakdowns.* Cross-references within an alphanumerically designated paragraph (e.g., PG-1, UIG-56.1, NCD-3223) do not include the alphanumeric designator of that paragraph. The cross-references to subparagraph breakdowns follow the hierarchy of the designators under which the breakdown appears. The following examples show the format:

- (1) If X.1(c)(1)(-a) is referenced in X.1(c)(1), it will be referenced as (-a).
- (2) If X.1(c)(1)(-a) is referenced in X.1(c)(2), it will be referenced as (1)(-a).
- (3) If X.1(c)(1)(-a) is referenced in X.1(e)(1), it will be referenced as (c)(1)(-a).
- (4) If X.1(c)(1)(-a) is referenced in X.2(c)(2), it will be referenced as X.1(c)(1)(-a).

ASMENORMDOC.COM : Click to view the full PDF of ASME BPVC.II.B (ASME BPVC Section II part B) 2025

INTENTIONALLY LEFT BLANK

# STATEMENT OF POLICY ON THE USE OF ASME MATERIAL SPECIFICATIONS

(25)

The ASME material specifications in Section II, Part A or Section II, Part B shall be used when ordering, producing, and certifying materials for ASME BPV Code construction. The use of a specification not in Section II, Part A or Section II, Part B is acceptable only when it is referenced in an approved Code Case.

A complete list of ASME material specifications can be found in Mandatory Appendix II, Tables II-200-1 and II-200-2. Since the body of ASME material specifications does not originate with the Section II committee, at times wording may be found that differs from ASME BPV Code requirements. This Statement of Policy outlines the Section II committee's position on the following:

(a) *Scope.* Some specifications contain statements in the Scope about the service temperatures for listed alloys. Others contain statements that restrict alloy application to a particular component (e.g., heat exchangers, condensers). Such statements are to be viewed as guidance in the corresponding ASME material specification. Alloys approved for ASME BPV Code construction are restricted by maximum design temperatures stipulated in Section II, Part D, and any stipulations of the individual construction Codes.

(b) *Units.* Specifications often designate one system of units as the standard for the specification with conversions of the other being cited as for information only. Compliance and acceptance for the purposes of Code usage is not governed by this. Section II, Part D has a U.S. Customary volume and an SI volume for mechanical and physical properties of all materials approved for Code construction.

(c) *References.* References to other material specifications within the text often carry the original title given to it by the parent organization. The following are two examples:

(1) From 2021 Edition of Section II, Part A, SA-203

4.1 *Steelmaking Practice* — The steel shall be killed and shall conform to the fine grain size requirement of Specification A20/A20M.

(2) From 2021 Edition of Section II, Part B, SB-98/SB-98M

9.1 Refer to the appropriate paragraphs in Specification B249/B249M with particular reference to the following tables.

Such references shall be interpreted as referring to the corresponding ASME material specification. If no corresponding ASME specification exists, then the user is bound to the latest edition of the cited specification.

(d) *Ordering Information.* The Ordering Information section of some specifications state that furnishing test reports and certification is optional. This is not valid for ASME BPVC. When alloys are purchased for use in ASME construction, test reports and certifications shall be furnished to the purchaser.

(e) *Listed Alloys.* To be used for Code construction, any alloy listed in a specification shall also have allowable stress values or mechanical property values, as appropriate, in the ASME BPV Code. Though exceptions exist, these values are typically found in Section II, Part D or a Code Case for most Code-approved materials.

(f) *Table Notes.* Table notes are mandatory.

(g) *Main Body Notes.* Notes within the main body of the text are for information only.

(h) *Terminology.* If a specification contains a term that has not been defined in the ASME BPV Code, then it is acceptable to refer to the term's definition set forth by the corresponding standard's organization (see Mandatory Appendix II, II-200 for information on how to identify the organization).

Material produced to an acceptable material specification is not limited to country of origin. Before the material is ordered, it is the responsibility of the user to ensure that the intended construction Code permits materials certified to the desired specification.

With the exception of ASTM International, ASME has not entered into copyright agreements with publishers of material specifications. Limits on usage appear on the specification's cover sheets. For sources from which an official English-language version of a specification can be purchased, see Nonmandatory Appendix A.

ASMENORMDOC.COM : Click to view the full PDF of ASME BPVC.II.B (ASME BPVC Section II part B) 2025

INTENTIONALLY LEFT BLANK

# SPECIFICATION FOR ALUMINUM-ALLOY SAND CASTINGS



**SB-26/SB-26M**

(Identical with ASTM Specification B26/B26M-11 except that certification and test reports have been made mandatory, and ASME welding requirements are invoked.)

ASMENORMDOC.COM : Click to view the full PDF of ASME BPVC.II.B (ASME BPVC Section II part B) 2025

# Standard Specification for Aluminum-Alloy Sand Castings

## 1. Scope

1.1 This specification covers aluminum-alloy sand castings designated as shown in Table 1.

1.2 This specification is not intended for aluminum-alloy sand castings used in aerospace applications.

1.3 Alloy and temper designations are in accordance with ANSI H35.1/H35.1M. Unified Numbering System alloy designations are in accordance with Practice E527.

1.4 Unless the order specifies the “M” specification designation, the material shall be furnished to the inch-pound units.

1.5 For acceptance criteria for inclusion of new aluminum and aluminum alloys and their properties in this specification, see Annex A1 and Annex A2.

1.6 The values stated in either SI units or inch-pound units are to be regarded separately as standard. The values stated in each system may not be exact equivalents; therefore, each system shall be used independently of the other. Combining values from the two systems may result in nonconformance with the standard.

1.7 *This standard does not purport to address all of the safety concerns, if any, associated with its use. It is the responsibility of the user of this standard to establish appropriate safety and health practices and determine the applicability of regulatory limitations prior to use.*

## 2. Referenced Documents

2.1 The following documents of the issue in effect on date of material purchase form a part of this specification to the extent referenced herein:

### 2.2 ASTM Standards:

B179 Specification for Aluminum Alloys in Ingot and Molten Forms for Castings from All Casting Processes

B275 Practice for Codification of Certain Nonferrous Metals and Alloys, Cast and Wrought

B557 Test Methods for Tension Testing Wrought and Cast Aluminum- and Magnesium-Alloy Products

B557M Test Methods for Tension Testing Wrought and Cast Aluminum- and Magnesium-Alloy Products (Metric)

B660 Practices for Packaging/Packing of Aluminum and Magnesium Products

B881 Terminology Relating to Aluminum- and Magnesium-Alloy Products

B917/B917M Practice for Heat Treatment of Aluminum-Alloy Castings from All Processes

D3951 Practice for Commercial Packaging

E29 Practice for Using Significant Digits in Test Data to Determine Conformance with Specifications

E34 Test Methods for Chemical Analysis of Aluminum and Aluminum-Base Alloys

E94 Guide for Radiographic Examination

E155 Reference Radiographs for Inspection of Aluminum and Magnesium Castings

E165 Practice for Liquid Penetrant Examination for General Industry

E527 Practice for Numbering Metals and Alloys in the Unified Numbering System (UNS)

E607 Test Method for Atomic Emission Spectrometric Analysis Aluminum Alloys by the Point to Plane Technique Nitrogen Atmosphere

E716 Practices for Sampling and Sample Preparation of Aluminum and Aluminum Alloys for Determination of Chemical Composition by Spectrochemical Analysis

E1251 Test Method for Analysis of Aluminum and Aluminum Alloys by Spark Atomic Emission Spectrometry

E2422 Digital Reference Images for Inspection of Aluminum Castings

IEEE/ASTM SI 10 Standard for Use of the International System of Units (SI): The Modern Metric System

### 2.3 AMS Standard:

AMS 2771 Heat Treatment of Aluminum Alloy Castings

TABLE 1 Chemical Composition Limits

NOTE 1—When single units are shown, these indicate the maximum amounts permitted.

NOTE 2—Analysis shall be made for the elements for which limits are shown in this table.

NOTE 3—The following applies to all specified limits in this table: For purposes of determining conformance to these limits, an observed value or a calculated value obtained from analysis shall be rounded to the nearest unit in the last right-hand place of figures used in expressing the specified limit in accordance with the rounding method of Practice E29.

Alloy		Aluminum	Composition, (Values in Weight Percent)										Others	
ANSI	UNS		Silicon	Iron	Copper	Man-ganese	Magne-sium	Chromium	Nickel	Zinc	Tin	Titanium	Each	Total
201.0	A02010	remainder	0.10	0.15	4.0–5.2	0.20–0.50	0.15–0.55	...	...	...	...	0.15–0.35	0.05 <sup>A</sup>	0.10
204.0	A02040	remainder	0.20	0.35	4.2–5.0	0.10	0.15–0.35	...	0.05	0.10	0.05	0.15–0.30	0.05	0.15
242.0	A02420	remainder	0.7	1.0	3.7–4.5	0.35	1.2–1.8	0.25	1.7–2.3	0.35	...	0.25	0.05	0.15
A242.0	A12420	remainder	0.6	0.8	3.7–4.5	0.10	1.2–1.7	0.15–0.25	1.8–2.3	0.10	...	0.07–0.20	0.05	0.15
295.0	A02950	remainder	0.7–1.5	1.0	4.0–5.0	0.35	0.03	...	...	0.35	...	0.25	0.05	0.15
319.0	A03190	remainder	5.5–6.5	1.0	3.0–4.0	0.50	0.10	...	0.35	1.0	...	0.25	...	0.50
328.0	A03280	remainder	7.5–8.5	1.0	1.0–2.0	0.20–0.6	0.20–0.6	0.35	0.25	1.5	...	0.25	...	0.50
355.0	A03550	remainder	4.5–5.5	0.6 <sup>B</sup>	1.0–1.5	0.50 <sup>B</sup>	0.40–0.6	0.25	...	0.35	...	0.25	0.05	0.15
C355.0	A33550	remainder	4.5–5.5	0.20	1.0–1.5	0.10	0.40–0.6	...	...	0.10	...	0.20	0.05	0.15
356.0	A03560	remainder	6.5–7.5	0.6 <sup>B</sup>	0.25	0.35 <sup>B</sup>	0.20–0.45	...	...	0.35	...	0.25	0.05	0.15
A356.0	A13560	remainder	6.5–7.5	0.20	0.20	0.10	0.25–0.45	...	...	0.10	...	0.20	0.05	0.15
443.0	A04430	remainder	4.5–6.0	0.8	0.6	0.50	0.05	0.25	...	0.50	...	0.25	...	0.35
B443.0	A24430	remainder	4.5–6.0	0.8	0.15	0.35	0.05	...	...	0.35	...	0.25	0.05	0.15
512.0	A05120	remainder	1.4–2.2	0.6	0.35	0.8	3.5–4.5	0.25	...	0.35	...	0.25	0.05	0.15
514.0	A05140	remainder	0.35	0.50	0.15	0.35	3.5–4.5	...	...	0.15	...	0.25	0.05	0.15
520.0	A05200	remainder	0.25	0.30	0.25	0.15	9.5–10.6	...	...	0.15	...	0.25	0.05	0.15
535.0	A05350	remainder	0.15	0.15	0.05	0.10–0.25	6.2–7.5	...	...	...	...	0.10–0.25	0.05 <sup>C</sup>	0.15
705.0	A07050	remainder	0.20	0.8	0.20	0.40–0.6	1.4–1.8	0.20–0.40	...	2.7–3.3	...	0.25	0.05	0.15
707.0	A07070	remainder	0.20	0.8	0.20	0.40–0.6	1.8–2.4	0.20–0.40	...	4.0–4.5	...	0.25	0.05	0.15
710.0 <sup>D</sup>	A07100	remainder	0.15	0.50	0.35–0.65	0.05	0.6–0.8	...	...	6.0–7.0	...	0.25	0.05	0.15
712.0 <sup>D</sup>	A07120	remainder	0.30	0.50	0.25	0.10	0.50–0.65	0.40–0.6	...	5.0–6.5	...	0.15–0.25	0.05	0.20
713.0	A07130	remainder	0.25	1.1	0.40–1.0	0.6	0.20–0.50	0.35	0.15	7.0–8.0	...	0.25	0.10	0.25
771.0	A07710	remainder	0.15	0.15	0.10	0.10	0.8–1.0	0.06–0.20	...	6.5–7.5	...	0.10–0.20	0.05	0.15
850.0	A08500	remainder	0.7	0.7	0.7–1.3	0.10	0.10	...	0.7–1.3	...	5.5–7.0	0.20	...	0.30
851.0 <sup>D</sup>	A08510	remainder	2.0–3.0	0.7	0.7–1.3	0.10	0.10	...	0.30–0.7	...	5.5–7.0	0.20	...	0.30
852.0 <sup>D</sup>	A08520	remainder	0.40	0.7	1.7–2.3	0.10	0.6–0.9	...	0.9–1.5	...	5.5–7.0	0.20	...	0.30

<sup>A</sup> Contains silver 0.40–1.0 %.

<sup>B</sup> If iron exceeds 0.45 %, manganese content shall not be less than one half of the iron content.

<sup>C</sup> Contains beryllium 0.003–0.007 %, boron 0.005 % max.

<sup>D</sup> 710.0 formerly A712.0, 712.0 formerly D712.0, 851.0 formerly A850.0, 852.0 formerly B850.0.

#### 2.4 American National Standards:

H35.1/H35.1(M) Alloy and Temper Designation System for Aluminum

#### 2.5 Military Standards:

MIL-STD-129 Marking for Shipment and Storage

MIL-STD-276 Impregnation of Porous Nonferrous Metal Castings

NAVSEA Technical Publication S9074-AR-GIB-010/278

#### 2.6 Federal Standard:

Fed. Std. No. 123 Marking for Shipment (Civil Agencies)

#### 2.7 Other Standards:

EN 14242 Aluminum and Aluminum Alloys — Chemical Analysis — Inductively Coupled Plasma Optical Emission Spectral Analysis

### 3. Terminology

3.1 *Definitions*—Refer to Terminology B881 for definitions of product terms used in this specification.

3.2 *sand casting*—a metal object produced by pouring molten metal into a sand mold and allowing it to solidify.

### 4. Ordering Information

4.1 Orders for material under this specification shall include the following information (1.4 and 1.5):

4.1.1 This specification designation (which includes the number, year, and revision letter, if applicable),

NOTE 1—For inch-pound application, specify Specification B26 and for metric application specify Specification B26M. Do not mix units.

4.1.2 The quantity in either pieces or pounds [kilograms],

4.1.3 Alloy (Section 7 and Table 1),

4.1.4 Temper (Section 10 and Table 2), and

4.1.5 Applicable drawing or part number,

4.2 Additionally, orders for material to this specification shall include the following information when required by the purchaser:

4.2.1 Whether chemical analysis and tensile property reports are required (Table 1 and Table 2),

4.2.2 Whether castings or test bars, or both, may be artificially aged for Alloys 705.0-T5, 707.0-T5, 712.0-T5, and 713.0-T5 (10.2) and whether yield strength tests are required for these alloys;

TABLE 2 Tensile Requirements<sup>A</sup> (Inch-Pound Units)

NOTE 1—For purposes of determining conformance with this specification, each value for tensile strength and yield strength shall be rounded to the nearest 0.1 ksi and each value for elongation shall be rounded to the nearest 0.5 %, both in accordance with the rounding method of Practice E29.

Alloy		Temper <sup>B</sup>	Tensile Strength, min, ksi	Yield Strength (0.2 % offset), min, ksi	Elongation in 2 in. or 4 x diameter, min, %	Typical Brinell Hard- ness, <sup>C</sup> 500 kgf, 10 mm
ANSI <sup>D</sup>	UNS					
201.0	A02010	T7	60.0	50.0	3.0	...
204.0	A02040	T4	45.0	28.0	6.0	...
242.0	A02420	O <sup>E</sup>	23.0	F	F	70
		T61	32.0	20.0	F	105
A242.0	A12420	T75	29.0	F	1.0	75
295.0	A02950	T4	29.0	13.0	6.0	60
		T6	32.0	20.0	3.0	75
		T62	36.0	28.0	F	95
		T7	29.0	16.0	3.0	70
319.0	A03190	F	23.0	13.0	1.5	70
		T5	25.0	F	F	80
		T6	31.0	20.0	1.5	80
328.0	A03280	F	25.0	14.0	1.0	60
		T6	34.0	21.0	1.0	80
355.0	A03550	T6	32.0	20.0	2.0	80
		T51	25.0	18.0	F	65
		T71	30.0	22.0	F	75
C355.0	A33550	T6	36.0	25.0	2.5	...
356.0	A03560	F	19.0	9.5	2.0	55
		T6	30.0	20.0	3.0	70
		T7	31.0	F	F	75
		T51	23.0	16.0	F	60
		T71	25.0	18.0	3.0	60
A356.0	A13560	T6	34.0	24.0	3.5	80
		T61	35.0	26.0	1.0	...
443.0	A04430	F	17.0	7.0	3.0	40
B443.0	A24430	F	17.0	6.0	3.0	40
512.0	A05120	F	17.0	10.0	...	50
514.0	A05140	F	22.0	9.0	6.0	50
520.0	A05200	T4	42.0	22.0	12.0	75
535.0	A05350	F	35.0	18.0	9.0	70
705.0	A07050	T5	30.0	17.0 <sup>G</sup>	5.0	65
707.0	A07070	T7	37.0	30.0 <sup>G</sup>	1.0	80
710.0 <sup>H</sup>	A07100	T5	32.0	20.0	2.0	75
712.0 <sup>H</sup>	A07120	T5	34.0	25.0 <sup>G</sup>	4.0	75
713.0	A07130	T5	32.0	22.0	3.0	75
771.0	A07710	T5	42.0	38.0	1.5	100
		T51	32.0	27.0	3.0	85
		T52	36.0	30.0	1.5	85
		T6	42.0	35.0	5.0	90
		T71	48.0	45.0	2.0	120
850.0	A08500	T5	16.0	F	5.0	45
851.0 <sup>H</sup>	A08510	T5	17.0	F	3.0	45
852.0 <sup>H</sup>	A08520	T5	24.0	18.0	F	60

<sup>A</sup> If agreed upon between the manufacturer and the purchaser, other mechanical properties may be obtained by other heat treatments such as annealing, aging, or stress relieving.

<sup>B</sup> Refer to ANSI H35.1/H35.1M, or both, for description of tempers.

<sup>C</sup> For information only, not required for acceptance.

<sup>D</sup> ASTM alloy designations are recorded in Practice B275.

<sup>E</sup> Formerly designated as 222.0-T2 and 242.0-T21.

<sup>F</sup> Not required.

<sup>G</sup> Yield strength to be determined only when specified in the contract or purchase order.

<sup>H</sup> 710.0 formerly A712.0, 712.0 formerly D712.0, 851.0 formerly A850.0, 852.0 formerly B850.0.

4.2.3 Whether test specimens cut from castings are required in addition to, or instead of, separately cast specimens (Sections 10 and 13);

4.2.4 Whether repairs are permissible (16.1),

4.2.5 Whether inspection is required at the producer's works (Section 18);

4.2.6 DELETED

4.2.7 Whether surface requirements shall be checked against observational standards where such standards are established (19.1);

4.2.8 Whether liquid penetrant inspection is required (19.2);

4.2.9 Whether radiographic inspection is required and, if so, the radiographic grade of casting required (19.3, Table 3);

4.2.10 Whether foundry control is required (Section 9); and

4.2.11 Whether Practice B660 applies and, if so, the levels of preservation, packaging, and packing required (23.4).

## 5. Quality Assurance

5.1 Unless otherwise specified in the contract or purchase order, the producer shall be responsible for the performance of all inspections and test requirements specified herein. Unless disapproved by the purchaser, the producer may use his own or

**TABLE 3 Discontinuity-Level Requirements for Aluminum Castings in Accordance with Film Reference Radiographs E155 or Digital Reference Radiographs E2422**

Discontinuity	Radiograph	Section Thickness in. [mm]							
		Grade A <sup>A</sup>		Grade B		Grade C		Grade D	
		¼ [6.4]	¾ [19.0]	¼ [6.4]	¾ [19.0]	¼ [6.4]	¾ [19.0]	¼ [6.4]	¾ [19.0]
Gas holes	1.1	none		1	1	2	2	5	5
Gas porosity (round)	1.21	none		1	1	3	3	7	7
Gas porosity (elongated)	1.22	none		1	1	3	4	5	5
Shrinkage cavity	2.1	none		1	<sup>B</sup>	2	<sup>B</sup>	3	3
Shrinkage porosity or sponge	2.2	none		1	1	2	2	4	3
Foreign material (less dense material)	3.11	none		1	1	2	2	4	4
Foreign material (more dense material)	3.12	none		1	1	2	1	4	3
Segregation	3.2	none							none
Cracks	...	none		none			none		none
Cold shuts	...	none		none			none		none
Surface irregularity	...	...				not to exceed drawing tolerance			
Core shift	...	...				not to exceed drawing tolerance			

<sup>A</sup> Caution should be exercised in requesting Grade A.

<sup>B</sup> Not available.

any other suitable facilities for the performance of the inspection and test requirements specified herein. The purchaser shall have the right to perform any of the inspections and tests set forth in this specification where such inspections are deemed necessary to confirm that the material conforms to prescribed requirements.

## 6. Manufacture

6.1 The responsibility of furnishing castings that can be laid out and machined to the finished dimensions within the permissible variations specified, as shown on the blueprints or drawings, shall rest with the producer, except where pattern equipment is furnished by the purchaser.

## 7. Chemical Composition

7.1 The Product shall conform to the chemical composition limits prescribed in Table 1. Conformance shall be determined by the producer by taking samples at the time castings are poured in accordance with Practice E716 and analyzed in accordance with Test Methods E607, E1251, or E34, or EN 14242. If the producer has determined the composition of the material during casting, they shall not be required to sample and analyze the finished product.

7.2 If it becomes necessary to analyze castings for conformance to chemical composition limits, the method used to sample castings for the determination of chemical composition shall be by agreement between the producer and the purchaser. Analysis shall be performed in accordance with Practice E716, Test Methods E607, E1251, or E34, or EN 14242 (ICP method).

7.3 Other methods of analysis or in the case of a dispute the method of analysis shall be agreed upon by the producer and the purchaser.

7.4 A sample for determining of chemical composition shall be taken to represent the following:

7.4.1 Not more than 4000 lb [2000 kg] of clean castings (gates and risers removed) or a single casting poured from one furnace.

7.4.2 The maximum elapsed time between determinations shall be established for each alloy, but in any case the maximum elapsed time shall not exceed 8 h.

## 8. Material Requirements—Castings Produced for Governmental and Military Agencies

8.1 Unless otherwise specified, only aluminum alloy conforming to the requirements of Specification B179 or producer's foundry scrap (identified as being made from alloy conforming to Specification B179) shall be used in the remelting furnace from which molten metal is taken for pouring directly into castings. Additions of small amounts of modifiers and grain refining elements or alloys are permitted.

8.1.1 Pure materials, recycled materials, and master alloys may be used to make alloys conforming to this specification, provided chemical analysis can be taken and adjusted to conform to Table 1 prior to pouring any castings.

## 9. Foundry Control—Castings Produced for Governmental or Military Agencies, or Both

9.1 When specified, castings shall be produced under foundry control approved by the purchaser. Foundry control shall consist of examination of castings by radiographic or other approved methods for determining internal discontinuities until the gating, pouring, and other foundry practices have been established to produce castings meeting the quality standards furnished by the purchaser or agreed upon between the purchaser and the producer. When foundry practices have been so established, the production method shall not be significantly changed without demonstrating to the satisfaction of the purchaser that the change does not adversely affect the quality of the castings. Minor changes in pouring temperature of  $\pm 50^\circ\text{F}$  [ $\pm 28^\circ\text{C}$ ] from the established nominal temperature are permissible.

## 10. Tensile Properties

10.1 The separately cast test specimens representing the castings shall meet the mechanical properties prescribed in Table 2.

10.2 Although Alloys 705.0, 707.0, 712.0, and 713.0 are most frequently used in the naturally aged condition, by agreement between the producer and the purchaser, the castings may be artificially aged to the T5 temper. The producer and the purchaser may also agree to base the acceptance of castings on artificially aged test bars. The conditions of

artificial aging shown in Practice B917/B917M shall be employed unless other conditions are accepted by mutual consent.

10.3 When specified, the tensile strength, yield strength, and elongation values of specimens cut from castings shall be not less than 75 % of the tensile and yield strength values and not less than 25 % of the elongation values specified in Table 2 [Table 4]. The measurement of the elongation is not required for test specimens cut from castings if 25 % of the specified minimum elongation value published in Table 2 [Table 4] is 0.5 % or less. If grade D quality castings as described in Table 3 are specified, no tensile tests shall be specified nor tensile requirements be met on specimens cut from castings.

## 11. Workmanship, Finish, and Appearance

11.1 The finished castings shall be uniform in composition and free of blowholes, cracks, shrinks, and other discontinuities except as designated and agreed upon as acceptable by the purchaser.

## 12. Number of Tests and Retests

12.1 Unless otherwise agreed upon between the purchaser and producer, a minimum of two tension test specimens shall be separately cast and tested to represent the following:

12.1.1 Not more than 4000 lb [2000 kg] of clean castings (gates and risers removed) or a single casting poured from one furnace.

12.1.2 The castings poured continuously from one furnace in not more than eight consecutive hours.

12.2 When tensile properties from castings are to be determined, one per melt-heat combination shall be tested unless otherwise shown on the drawing or specified in the purchase order.

12.3 If any test specimen shows defective machining or flaws, it may be discarded; in which case the purchaser and the producer shall agree upon the selection of another specimen in its stead.

12.4 If the results of the tension tests do not conform to the requirements prescribed in Table 2 [Table 4]; the test bars representative of the castings may be retested in accordance with the replacement tests and retest provisions of Test Methods B557 and B557M, and the results of retests shall conform to the requirements as to mechanical properties specified in Table 2 [Table 4].

## 13. Specimen Preparation

13.1 The tension test specimens shall be cast to size in sand without chills in accordance with the dimensions shown in Fig. 1 [Fig. 2]. They shall not be machined prior to test except to adapt the grip ends in such a manner as to ensure axial loading.

13.2 The recommended method for casting tension test specimens is shown in Fig. 1 [Fig. 2].

13.3 When properties of castings are to be determined, tension test specimens shall be cut from the locations designated on the drawing, unless otherwise negotiated. If no locations are designated, one or more specimens shall be taken to include locations having significant variation in casting thickness, except that specimens shall not be taken from areas directly under risers. The tension test specimens shall be the

standard 0.500-in. [12.5-mm] diameter specimens shown in Fig. 9 of Test Methods B557 and B557M or a round specimen of smaller size proportional to the standard specimen.

	in.	mm
Diameter of reduced section	0.250	6.00
Length of reduced section	1¼	36
Gage length	1.000	30.00
Radius of fillet	¾ <sub>16</sub>	6
Diameter of end section	¾	9
Overall length:		
With shouldered ends	2¾	60
With threaded ends	3	75
With plain cylindrical ends	4	100

When necessary, a rectangular specimen may be used proportional to that shown for the 0.500-in. [12.5-mm] wide specimen in Fig. 6 of Test Methods B557 and B557M, but in no case shall its dimensions be less than the following:

	in.	mm
Width of reduced section	¼	6.00
Length of reduced section	1¼	32
Radius of fillet	¼	6
Overall length	4	100
Thickness	0.100	2.50

The specific elongation values shall not apply to tests of rectangular specimens.

13.4 If the castings are to be heat treated and separately cast specimens are to be used, the specimens representing such castings shall be heat treated with the castings they represent. If castings are to be heat treated and tests are to be obtained on the castings, the test specimens shall be taken from the castings after heat treatment.

## 14. Test Methods

14.1 The determination of chemical composition shall be made in accordance with suitable chemical (Test Methods E34), or spectrochemical (Test Methods E607 and E1251), methods. Other methods may be used only when no published ASTM method is available. In case of dispute, the methods of analysis shall be agreed upon between the producer and purchaser.

14.2 The tensile properties shall be determined in accordance with Test Methods B557 and B557M.

## 15. Heat Treatment

15.1 Heat treatment of castings shall be performed in accordance with Practice B917/B917M or AMS 2771.

## 16. Repair of Castings

16.1 Castings may be repaired only by processes approved and agreed upon between the producer and purchaser, that is, welding, impregnation, peening, blending, soldering, and so forth. Limitations on the extent and frequency of such repairs, and methods of inspection of repaired areas should also be agreed upon.

16.2 The welding procedure and welders shall be qualified in accordance with Section IX of the ASME Boiler and Pressure Vessel Code.

TABLE 4 Tensile Requirements (SI Units)—[Metric]<sup>A</sup>

NOTE 1—For purposes of determining conformance with this specification, each value for tensile strength and yield strength shall be rounded to the nearest 1 MPa and each value for elongation shall be rounded to the nearest 0.5 %, both in accordance with the rounding method of Practice E29.

Alloy		Temper <sup>B</sup>	Tensile Strength, min, MPa <sup>C</sup>	Yield Strength (0.2 % offset), min, MPa <sup>C</sup>	Elongation in 5× diameter, min %	Typical Brinell Hardness, <sup>D</sup> 500 kgf, 10 mm
ANSI <sup>E</sup>	UNS					
201.0	A02010	T7	415	345	3.0	...
204.0	A02040	T4	310	195	6.0	...
242.0	A02420	O <sup>F</sup>	160	<sup>G</sup>	<sup>G</sup>	70
		T61	220	140	<sup>G</sup>	105
A242.0	A12420	T75	200	<sup>G</sup>	1.0	75
295.0	A02950	T4	200	90	6.0	60
		T6	220	140	3.0	75
		T62	250	195	<sup>G</sup>	95
		T7	200	110	3.0	70
319.0	A03190	F	160	90	1.5	70
		T5	170	<sup>G</sup>	<sup>G</sup>	80
		T6	215	140	1.5	80
328.0	A03280	F	170	95	1.0	60
		T6	235	145	1.0	80
355.0	A03550	T6	220	140	2.0	80
		T51	170	125	<sup>G</sup>	65
		T71	205	150	<sup>G</sup>	75
C355.0	A33550	T6	250	170	2.5	...
356.0	A03560	F	130	65	2.0	55
		T6	205	140	3.0	70
		T7	215	<sup>G</sup>	<sup>G</sup>	75
		T51	160	110	<sup>G</sup>	60
		T71	170	125	3.0	60
A356.0	A13560	T6	235	165	3.5	80
		T61	245	180	1.0	...
443.0	A04430	F	115	50	3.0	40
B443.0	A24430	F	115	40	3.0	40
512.0	A05120	F	115	70	...	50
514.0	A05140	F	150	60	6.0	50
520.0	A05200	T4	290	150	12.0	75
535.0	A05350	F	240	125	9.0	70
705.0	A07050	T5	205	115 <sup>H</sup>	5.0	65
707.0	A07070	T7	255	205 <sup>H</sup>	1.0	80
710.0 <sup>I</sup>	A07100	T5	220	140	2.0	75
712.0 <sup>I</sup>	A07120	T5	235	170 <sup>H</sup>	4.0	75
713.0	A07130	T5	220	150	3.0	75
771.0	A07710	T5	290	260	1.5	100
		T51	220	185	3.0	85
		T52	250	205	1.5	85
		T6	290	240	5.0	90
		T71	330	310	2.0	120
850.0	A08500	T5	110	<sup>G</sup>	5.0	45
851.0 <sup>I</sup>	A08510	T5	115	<sup>G</sup>	3.0	45
852.0 <sup>I</sup>	A08520	T5	165	125	<sup>G</sup>	60

<sup>A</sup> If agreed upon between the manufacturer and the purchaser, other mechanical properties may be obtained by other heat treatments such as annealing, aging, or stress relieving.

<sup>B</sup> Temper designations:

F As fabricated.

O Annealed.

T1 Cooled from an elevated temperature shaping process and naturally aged to a substantially stable condition.

T4 Solution heat-treated and naturally aged to a substantially stable condition.

T5 Cooled from an elevated temperature shaping process and then artificially aged.

T6 Solution heat-treated and then artificially aged.

T7 Solution heat-treated and stabilized.

Additional digits, the first of which shall not be zero, may be added to designation T1 through T10 to indicate a variation in treatment that significantly alters the characteristics of the product.

<sup>C</sup> For explanation of the SI unit "MPa" see Appendix X2.

<sup>D</sup> For information only, not required for acceptance.

<sup>E</sup> ASTM alloy designations are recorded in Practice B275.

<sup>F</sup> Formerly designated as 222.0-T2 and 242.0-T21.

<sup>G</sup> Not required.

<sup>H</sup> Yield strength to be determined only when specified in the contract or purchase order.

<sup>I</sup> 710.0 formerly A712.0, 712.0 formerly D712.0, 851.0 formerly A850.0, 852.0 formerly B850.0.

## 17. Repairing of Castings—Produced for Governmental and Military Agencies

### 17.1 Welding:

17.1.1 When welding is permitted, it shall be done by methods suitable for the particular alloy. Welding methods

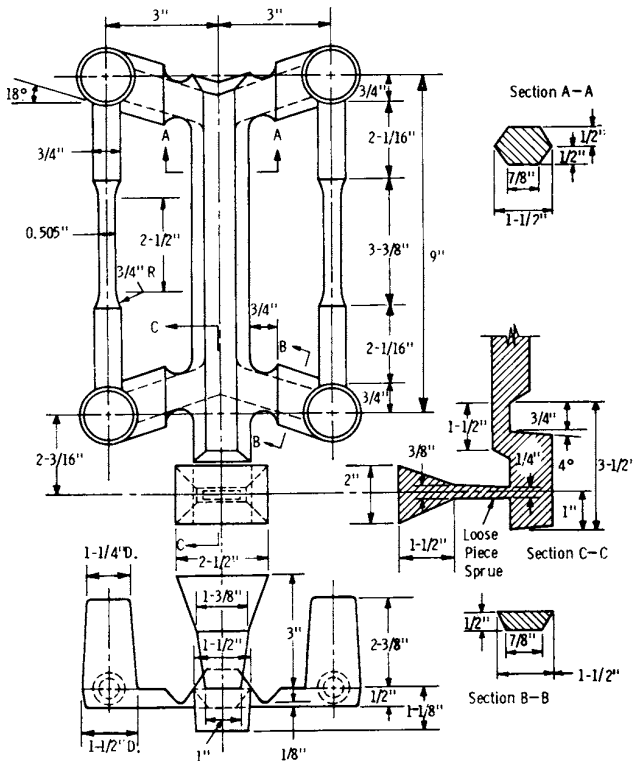

NOTE 1—1 in. = 25.4 mm.

FIG. 1 Tension Test Specimen Casting

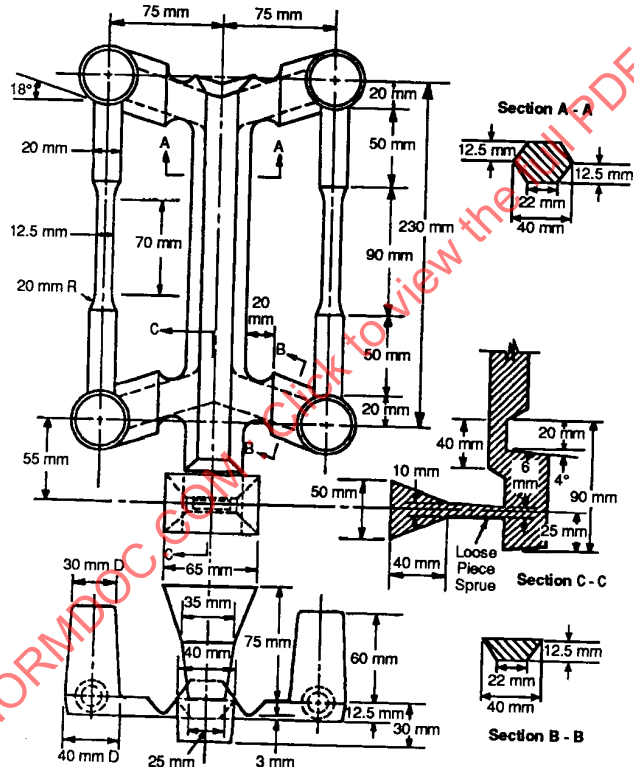

FIG. 2 Tension Test Specimen Casting [Metric]

shall be in accordance with such specifications as are referenced on the applicable drawings, or as are required by the contract or order.

17.1.2 All welding shall be done by qualified welders approved by the purchaser.

17.1.3 When castings are to be supplied in the heat-treated condition, they shall be heat treated to the required temper after welding, except that small arc welds may be performed without subsequent heat treatment upon approval of the purchaser.

17.1.4 Unless otherwise specified, castings that have been repaired by welding shall have the welded areas examined radiographically after all reworking and heat treatment have been completed.

17.1.5 All welds shall be free of cracks, excess gas, porosity, lack of fusion and meet the same quality requirements as the parent material.

17.1.6 Welded castings shall be marked with a symbol of three concentric circles with a letter or number designating the welder adjacent to the symbol. The outer circle of the symbol shall be not larger than 1/4 in. [6 mm] in outside diameter. All welded areas shall be encircled with a ring of white paint prior to submission for final inspection.

17.1.7 *Naval Shipboard Applications*—Repair welding of castings used in Naval shipboard pressure vessels, piping systems and machinery shall be performed in accordance with requirements for repair of castings specified in NAVSEA Technical Publication S9074-AR-GIB-010/278.

17.2 *Impregnation*—When impregnation is permitted, it shall be to correct general seepage leaks only and shall not be used to correct poor foundry technique or significant porosity. It shall be accomplished in accordance with MIL-STD-276. Unless otherwise authorized by the purchaser, castings which have been impregnated shall be marked “IMP.”

17.3 *Peening*—When peening is permitted, it shall be to correct localized minor seepage leaks and small surface imperfections only, or to disclose subsurface voids for purpose of inspection. Peening will not be permitted to repair cracks, cold shuts, shrinks, misruns, defects due to careless handling, or other similar major defects. Peening may be accomplished either hot or cold and shall be performed by methods which are acceptable to the purchaser. Peened castings shall be marked with Maltese cross approximately 1/4 in. [6 mm] high.

17.4 *Blending*—Blending with suitable grinders or other tools will be permitted for the removal of surface imperfections only, and shall not result in dimensions outside the tolerances shown on the applicable drawing.

**18. Source Inspection**

18.1 If the purchaser elects to make an inspection of the casting at the producer’s works, it shall be so stated in the contract or order.

18.2 If the purchaser elects to have inspection made at the producer’s works, the producer shall afford the inspector all reasonable facilities to satisfy him that the material is being furnished in accordance with this specification. All tests and inspection shall be so conducted as not to interfere unnecessarily with the operation of the works.

## 19. Foundry Inspection

19.1 Requirements such as surface finish, parting line projections, snagging projections where gates and risers were removed, and so forth, may be checked visually. It is advisable to have agreed-upon observational standards representing both acceptable and unacceptable material.

### 19.2 Liquid Penetrant Inspection:

19.2.1 When specified, liquid penetrant inspection shall be in accordance with Test Method E165, and the required sensitivity shall be specified.

19.2.2 Acceptance standards for discontinuities shall be agreed upon, including size and frequency per unit area and location.

### 19.3 Radiographic Inspection:

19.3.1 Radiographic inspection shall be in accordance with Guide E94 and Film Reference Radiographs E155.

19.3.2 When agreed upon between the manufacturer and purchaser digital radiographic inspection shall be in accordance with Guide E94 and Digital Reference Radiographs E2422.

19.3.3 Radiographic acceptance shall be in accordance with requirements selected from Table 3. Any modifications of this table and the frequency per unit area and location should also be agreed upon.

19.3.4 The number, film size, and orientation of radiographs and the number of castings radiographically inspected shall be agreed upon between the manufacturer and purchaser.

## 20. Rejection and Rehearing

20.1 Castings that show unacceptable defects revealed by operations subsequent to acceptance and within an agreed time may be rejected, and shall be replaced by the producer.

20.2 In the case of dissatisfaction regarding rejections based on chemical composition and mechanical properties specified in Section 7 and 10, respectively, the producer may make claim for rehearing as the basis of arbitration within a reasonable time after receipt by the producer of the rejection notification.

## 21. Certification

21.1 The producer shall furnish to the purchaser a certificate stating that each lot has been sampled, tested, and inspected in accordance with this specification, and has met the requirements. In addition, certification shall be supplied with the certification.

## 22. Identification and Repair Marking—Castings Produced for Government and Military Agencies

22.1 *Identification*—Unless otherwise specified, each casting shall be marked with the applicable drawing or part number. The marking shall consist of raised Arabic numerals,

and when applicable capital letters, cast integral. The location of the identification marking shall be as specified on the applicable drawing. When the location is not specified on the drawing, the drawing/part number shall be placed in a location mutually agreeable to the purchaser and producer.

22.1.1 *Lot Identification*—When practicable, each casting shall also be marked with the melt of inspection lot number.

22.2 *Lot*—A lot shall consist of all of the cleaned castings poured from the same heat or melt when subsequent heat treatment is not required.

22.2.1 When the castings consist of alloys which require heat treatment, the lot shall consist of all castings from the same melt or heat which have been heat treated in the same furnace charge, or if heat treated in a continuous furnace, all castings from the same melt or heat that are discharged from the furnace during a 4-h period.

22.3 *Repair Markings*—All identification markings indicating repairs as specified in 17.6, 17.2, and 17.3, shall be made with a waterproof marking fluid.

## 23. Packaging, Marking, and Shipping

23.1 The material shall be packaged in such a manner as to prevent damage in ordinary handling and transportation. The type of packaging and gross weight of individual containers shall be left to the discretion of the producer unless otherwise agreed upon. Packaging methods and containers shall be so selected as to permit maximum utility of mechanical equipment in unloading and subsequent handling. Each package or container shall contain only one size, alloy, and temper of material when packaged for shipment unless otherwise agreed upon.

23.2 Each package or container shall be marked with the purchase order number, drawing number, quantity, specification number, alloy and temper, gross and net weights, and the name of the producer.

23.3 Packages or containers shall be such as to ensure acceptance by common or other carriers for safe transportation at the lowest rate to the point of delivery.

23.4 When specified in the contract or purchase order, material shall be preserved, packaged, and packed in accordance with the requirements of Practices B660. The applicable levels shall be as specified in the contract or order. Marking for shipment of such material shall be in accordance with Fed. Std. No. 123 or Practice D3951 for civil agencies and MIL-STD-129 for military agencies.

## 24. Keywords

24.1 aluminum; sand casting

ANNEXES

(Mandatory Information)

A1. BASIS FOR INCLUSION OF PROPERTY LIMITS

A1.1 Limits are established at a level at which a statistical evaluation of the data indicates that 99 % of the population obtained from all standard material meets the limit with 95 % confidence. For the products described, mechanical property limits for the respective size ranges are based on the analyses of at least 100 data from standard production material with no

more than ten data from a given lot. All tests are performed in accordance with the appropriate ASTM test methods. For informational purposes, refer to “Statistical Aspects of Mechanical Property Assurance” in the Related Material section of the *Annual Book of ASTM Standards*, Vol 02.02.

A2. ACCEPTANCE CRITERIA FOR INCLUSION OF NEW ALUMINUM AND ALUMINUM ALLOYS IN THIS SPECIFICATION

A2.1 Prior to acceptance for inclusion in this specification, the composition of wrought or cast aluminum or aluminum alloy shall be registered in accordance with ANSI H35.1/H35.1(M). The Aluminum Association holds the Secretariat of ANSI H35 Committee and administers the criteria and procedures for registration.

A2.2 If it is documented that the Aluminum Association could not or would not register a given composition, an alternative procedure and the criteria for acceptance shall be as follows:

A2.2.1 The designation submitted for inclusion does not utilize the same designation system as described in ANSI H35.1/H35.1(M). A designation not in conflict with other designation systems or a trade name is acceptable.

A2.2.2 The aluminum or aluminum alloy has been offered for sale in commercial quantities within the prior twelve months to at least three identifiable users.

A2.2.3 The complete chemical composition limits are submitted.

A2.2.4 The composition is, in the judgement of the responsible subcommittee, significantly different from that of any other aluminum or aluminum alloy already in the specification.

A2.2.5 For codification purposes, an alloying element is any element intentionally added for any purpose other than grain

refinement and for which minimum and maximum limits are specified. Unalloyed aluminum contains a minimum of 99.00 % aluminum.

A2.2.6 Standard limits for alloying elements and impurities are expressed to the following decimal places:

Less than 0.001 %	0.000X
0.001 to but less than 0.01 %	0.00X
0.01 to but less than 0.10 %	
Unalloyed aluminum made by a refining process	0.0XX
Alloys and unalloyed aluminum not made by a refining process	0.0X
0.10 through 0.55 %	0.XX
(It is customary to express limits of 0.30 through 0.55 % as 0.X0 or 0.X5.)	
Over 0.55 %	0.X, X.X, and so forth
(except that combined Si + Fe limits for 99.00 % minimum aluminum must be expressed as 0.XX or 1.XX)	

A2.2.7 Standard limits for alloying elements and impurities are expressed in the following sequence: Silicon; Iron; Copper; Manganese; Magnesium; Chromium; Nickel; Zinc (Note A2.1); Titanium; Other Elements, Each; Other Elements, Total; Aluminum (Note A2.2).

NOTE A2.1—Additional specified elements having limits are inserted in alphabetical order of their chemical symbols between zinc and titanium, or are specified in footnotes.

NOTE A2.2—Aluminum is specified as minimum for unalloyed aluminum and as a remainder for aluminum alloys.

**APPENDIXES****(Nonmandatory Information)****X1. ALLOY PROPERTIES AND CHARACTERISTICS**

X1.1 The data in Table X1.1 are approximate and are supplied for general information only.

ASMENORMDOC.COM : Click to view the full PDF of ASME BPVC.II.B (ASME BPVC Section II part B) 2025

TABLE X1.1 Properties and Characteristics

NOTE 1—1 indicates best of group, 5 indicates poorest of group.

Alloy		Pattern Shrinkage Allowance, <sup>A</sup> in./ft [mm/m]	Approximate Melting Range, <sup>B</sup> °F [°C]	Resistance to Hot Cracking <sup>C</sup>	Pressure Tightness	Fluidity <sup>D</sup>	Solidification Shrinkage Tendency <sup>E</sup>	Normally Heat Treated	Resistance to Corrosion <sup>F</sup>	Machining <sup>G</sup>	Polishing <sup>H</sup>	Electroplating <sup>I</sup>	Anodizing (Appearance) <sup>J</sup>	Chemical Oxide Coating (Protection) <sup>K</sup>	Strength at Elevated Temperature <sup>L</sup>	Suitability for Welding <sup>M</sup>	Suitability for Brazing <sup>N</sup>
ANSI <sup>O</sup>	UNS																
201.0	A02010	[13]	1060–1200 [571–649]	4	3	3	4	yes	4	1	1	1	2	2	1	4	no
204.0	A02040	5/32 [13]	985–1200 [529–649]	4	3	3	4	yes	4	1	2	1	3	4	1	4	no
242.0	A02420	5/32 [13]	990–1175 [532–635]	4	3	3	4	yes	4	2	2	1	3	4	1	4	no
295.0	A02950	5/32 [13]	970–1190 [521–643]	4	4	3	3	yes	3	2	2	1	2	3	3	3	no
319.0	A03190	5/32 [13]	950–1125 [510–607]	2	2	2	2	yes	3	3	4	2	4	3	3	2	no
328.0	A03280	5/32 [13]	960–1135 [516–613]	1	1	1	1	yes	3	4	5	2	4	2	2	2	no
355.0	A03550	5/32 [13]	1015–1150 [546–621]	1	1	1	1	yes	3	3	3	1	4	2	2	2	no
C355.0	A33550	5/32 [13]	1015–1150 [546–621]	1	1	1	1	yes	3	3	3	1	4	2	2	2	no
356.0	A03560	5/32 [13]	1035–1135 [557–613]	1	1	1	1	yes	2	4	5	2	4	2	3	2	no
A356.0	A13560	5/32 [13]	1035–1135 [557–613]	1	1	1	1	yes	2	4	5	2	4	2	3	2	no
443.0	A04430	5/32 [13]	1065–1170 [574–632]	1	1	1	1	no	3	5	5	2	5	2	4	1	ltd
B443.0	A24430	5/32 [13]	1065–1170 [574–632]	1	1	1	1	no	2	5	5	2	5	2	4	1	ltd
514.0	A05140	5/32 [13]	1110–1185 [599–640]	4	5	5	5	no	1	1	1	5	1	1	2	4	no
520.0	A05200	1/10 [8]	840–1120 [449–604]	2	5	4	5	yes	1	1	1	4	1	1	<sup>P</sup>	5	no
535.0	A05350	5/32 [13]	1020–1165 [549–629]	3	5	5	5	no	1	1	1	5	1	1	3	4	no
705.0	A07050	3/16 [16]	1105–1180 [596–638]	5	3	4	4	aged only	2	1	1	3	2	2	5	4	yes
707.0	A07070	3/16 [16]	1085–1165 [585–629]	5	3	4	4	yes	2	1	1	3	2	2	5	4	yes
710.0 <sup>O</sup>	A07100	3/16 [16]	1105–1195 [596–646]	5	3	4	4	aged only	2	1	1	2	2	3	5	4	yes
712.0 <sup>O</sup>	A07120	3/16 [16]	1110–1185 [599–641]	5	3	4	4	aged only	2	1	1	2	2	3	5	4	yes
713.0	A07130	3/16 [16]	1100–1185 [593–641]	5	3	4	4	aged only	2	1	1	2	2	3	5	4	yes
771.0	A07710	3/16 [16]	1120–1190 [604–643]	5	3	4	4	yes	2	1	1	3	2	2	5	4	yes
850.0	A08500	5/32 [13]	435–1200 [224–649]	5	5	5	5	aged only	3	1	1	5	4	5	<sup>P</sup>	5	no
851.0 <sup>O</sup>	A08510	5/32 [13]	440–1165 [227–629]	4	4	5	4	aged only	3	1	1	5	4	5	<sup>P</sup>	5	no
852.0 <sup>O</sup>	A08520	5/32 [13]	400–1175 [204–635]	5	5	5	5	aged only	3	1	1	5	4	5	<sup>P</sup>	5	no

<sup>A</sup> Allowances for average castings. Shrinkage requirements will vary with intricacy of design and dimensions.

<sup>B</sup> Temperatures of solids and liquids are indicated; pouring temperatures will be higher.

<sup>C</sup> Ability of alloy to withstand contraction stresses while cooling through hot-short or brittle-temperature range.

<sup>D</sup> Ability of liquid alloy to flow readily in mold and fill thin sections.

<sup>E</sup> Decreased in volume accompanying freezing of alloy and measure of amount of compensating feed metal required in form of risers.

<sup>F</sup> Based on alloy resistance in standard-type salt-spray test.

<sup>G</sup> Composite rating based on ease of cutting, chip characteristics, quality of finish, and tool life. Ratings, in the case of heat-treatable alloys, based on a -T6 temper. Other tempers, particularly the annealed temper, may have lower rating.

<sup>H</sup> Composite rating based on ease and speed of polishing and quality of finish provided by typical polishing procedure.

<sup>I</sup> Ability of casting to take and hold an electroplate applied by present standard methods.

<sup>J</sup> Rated on lightness of color, brightness, and uniformity of clear anodized coating applied in sulfuric acid electrolyte.

<sup>K</sup> Rated on combined resistance of coating and base alloy to corrosion.

<sup>L</sup> Rating based on tensile and yield strengths at temperatures up to 500°F [260°C], after prolonged heating at testing temperature.

<sup>M</sup> Based on ability of material to be fusion welded with filler rod of same alloy.

<sup>N</sup> Refers to suitability of alloy to withstand brazing temperatures without excessive distortion or melting.

<sup>O</sup> ASTM alloy designations are recorded in Practice B275.

<sup>P</sup> Not recommended for service at elevated temperatures.

<sup>Q</sup> 710.0 formerly A712.0, 712.0 formerly D712.0, 851.0 formerly A850.0, 852.0 formerly B850.0.

## X2. SI UNITS

X2.1 The SI unit for strength properties now shown is in accordance with the International System of Units (SI) (IEEE/ASTM SI 10). The derived SI unit for force is the newton (N), which is defined as that force which when applied to a body having a mass of one kilogram gives it an acceleration of one metre per second squared ( $N = \text{kg}\cdot\text{m}/\text{s}^2$ ). The derived SI unit

for pressure or stress is the newton per square metre ( $\text{N}/\text{m}^2$ ), which has been named the pascal (Pa) by the General Conference on Weights and Measures. Since  $1 \text{ ksi} = 6\,894\,757 \text{ Pa}$ , the metric equivalents are expressed as megapascal (MPa), which is the same as  $\text{MN}/\text{m}^2$  and  $\text{N}/\text{mm}^2$ .

## X3. INACTIVE ALLOYS

X3.1 Alloys listed as inactive by the Aluminum Association—208.0 and 222.0. Listing the composition limits, mechanical properties, and characteristics of the alloys is a

method of preserving this data should it be needed at some future date.

**TABLE X3.1 Chemical Composition Limits—Inactive Alloys**

NOTE 1—All applicable notes and footnotes can be found in Table 1

Alloy			Composition, (Values in Weight Percent)										Others	
ANSI	UNS	Aluminum	Silicon	Iron	Copper	Man- ganese	Magne- sium	Chromium	Nickel	Zinc	Tin	Titanium	Each	Total
208.0	A02080	remainder	2.5-3.5	1.2	3.5-4.5	0.50	0.10	...	0.35	1.0	...	0.25	...	0.50
222.0	A02220	remainder	2.0	1.5	9.2-10.7	0.50	0.15-0.35	...	0.50	0.8	...	0.25	...	0.35

**TABLE X3.2 Tensile Requirements (Inch-Pound Units)—Inactive Alloys**

NOTE 1—All applicable notes and footnotes can be found in Table 2.

Alloy		Temper	Tensile Strength, min, ksi	Yield Strength (0.2% offset), min, ksi	Elongation in 2 in. or 4 x diameter, min, %	Typical Brinell Hard- ness, 500 kgf, 10 mm
ANSI	UNS					
208.0	A02080	F	19.0 (131)	120 (83)	1.5	55
222.0	A02220	O	23.0 (159)			80
		T6	30.0 (207)			115

**TABLE X3.3 Properties and Characteristics—Inactive Alloys**

NOTE 1—1 indicates best of group, 5 indicates poorest of group.

NOTE 2—All applicable notes and footnotes can be found in Table X1.1.

Alloy		Pattern Shrinkage Allowance, <sup>A</sup> in./ft [mm/m]	Approximate Melting Range, <sup>B</sup> °F [°C]	Resistance to Hot Cracking <sup>C</sup>	Pressure Tightness	Fluidity <sup>D</sup>	Solidification Shrinkage Tendency <sup>E</sup>	Normally Heat Treated	Resistance to Corrosion <sup>F</sup>	Machining <sup>G</sup>	Polishing <sup>H</sup>	Electroplating <sup>I</sup>	Anodizing (Appearance) <sup>J</sup>	Chemical Oxide Coating (Protection) <sup>K</sup>	Strength at Elevated Temperature <sup>L</sup>	Suitability for Welding <sup>M</sup>	Suitability for Brazing <sup>N</sup>
ANSI <sup>O</sup>	UNS																
208.0	A02080	5/32 [13]	970-1160 [521-627]	2	2	2	2	yes	4	3	3	2	3	3	3	2	no
222.0	A02220	5/32 [13]	965-1155 [518-624]	3	3	3	3	yes	4	1	2	1	3	4	1	4	no

ASME BPVC.II.B (ASME BPVC Section II part B) 2025

ASMENORMDOC.COM : Click to view the full PDF of ASME BPVC.II.B (ASME BPVC Section II part B) 2025

## SPECIFICATION FOR SEAMLESS COPPER PIPE, STANDARD SIZES



SB-42

(Identical with ASTM Specification B42-20 except that certification and mill test reports have been made mandatory, and nondestructive testing is required for all diameters.)

# Specification for Seamless Copper Pipe, Standard Sizes

## 1. Scope

1.1 This specification establishes the requirements for seamless copper pipe in all nominal or standard pipe sizes, both regular and extra-strong, suitable for use in plumbing, boiler feed lines, and for similar purposes.

1.2 *Units*—The values stated in inch-pound units are to be regarded as the standard. The values given in parentheses are mathematical conversions to SI units, which are provided for information only and are not considered standard.

1.3 The following safety hazard caveat pertains only to the test methods described in this specification.

1.3.1 *This standard does not purport to address all of the safety concerns, if any, associated with its use. It is the responsibility of the user of this standard to establish appropriate safety, health, and environmental practices and determine the applicability of regulatory limitations prior to use.*

1.4 *This international standard was developed in accordance with internationally recognized principles on standardization established in the Decision on Principles for the Development of International Standards, Guides and Recommendations issued by the World Trade Organization Technical Barriers to Trade (TBT) Committee.*

## 2. Referenced Documents

### 2.1 ASTM Standards:

B153 Test Method for Expansion (Pin Test) of Copper and Copper-Alloy Pipe and Tubing

B170 Specification for Oxygen-Free Electrolytic Copper—Refinery Shapes

B577 Test Methods for Detection of Cuprous Oxide (Hydrogen Embrittlement Susceptibility) in Copper

B601 Classification for Temper Designations for Copper and Copper Alloys—Wrought and Cast

B846 Terminology for Copper and Copper Alloys

B968/B968M Test Method for Flattening of Copper and Copper-Alloy Pipe and Tube

E8/E8M Test Methods for Tension Testing of Metallic Materials

E29 Practice for Using Significant Digits in Test Data to Determine Conformance with Specifications

E53 Test Method for Determination of Copper in Unalloyed Copper by Gravimetry

E62 Test Methods for Chemical Analysis of Copper and Copper Alloys (Photometric Methods) (Withdrawn 2010)

E243 Practice for Electromagnetic (Eddy Current) Examination of Copper and Copper-Alloy Tubes

E255 Practice for Sampling Copper and Copper Alloys for the Determination of Chemical Composition

E478 Test Methods for Chemical Analysis of Copper Alloys

E527 Practice for Numbering Metals and Alloys in the Unified Numbering System (UNS)

### 2.2 ASME Code:

ASME Boiler and Pressure Vessel Code

## 3. Terminology

### 3.1 Definitions:

3.1.1 For definitions of terms related to copper and copper alloys, refer to Terminology B846.

## 4. Ordering Information

4.1 Include the following specified choices when placing orders for product under this specification as applicable:

4.1.1 ASTM designation and year of issue;

4.1.2 Copper UNS No. designation, if required, (see Chemical Composition section);

4.1.3 Temper (see Temper section and Table 2);

4.1.4 Pipe size, regular or extra-strong (see Dimensions section and Table 3);

4.1.5 Length (see 10.3) if different than standard; and

4.1.6 Quantity—total weight, or total length or number of pieces of each size.

4.2 The following options are available, but may not be included unless specified at the time of placing of the order when required:

4.2.1 DELETED

4.2.2 If product is required for bending (see 6.2) and the temper to be furnished;

4.2.3 DELETED

4.2.4 DELETED

4.2.5 Hydrostatic test, if required (see Nondestructive Testing section);

4.2.5.1 If hydrostatic test pressure above 1000 psi is required;

4.2.6 Pneumatic test, if required (see Nondestructive Testing section);

4.2.7 If product is purchased for agencies of the U.S. Government (see the Other Requirements section of this specification); and

4.2.8 If specification number is required to be shown on each shipping unit (see Packaging and Package Marking section).

## 5. Chemical Composition

5.1 The material shall conform to the following chemical requirements:

Copper (incl silver), min, %	99.9
Phosphorus, max, %	0.04

5.1.1 Results of analysis on a product (check) sample shall conform to the composition requirements within the permitted analytical variance specified in Table 1.

5.2 The pipe shall be produced from one of the following coppers, and unless otherwise specified, any one of them is permitted to be furnished:

Copper UNS No.	Previously Used Designation	Type of Copper
C10200	OF	Oxygen-free without residual deoxidants
C10300		Oxygen-free, extra-low phosphorus
C10800		Oxygen-free, low phosphorus
C12000	DLP	Phosphorized, low residual phosphorus
C12200	DHP	Phosphorized, high residual phosphorus

TABLE 1 Chemical Requirements

Copper UNS No.	Copper (incl Silver), min, %	Phosphorus, %
C10200 <sup>A</sup>	99.95	...
C10300	99.95 <sup>B</sup>	0.001 to 0.005
C10800	99.95 <sup>B</sup>	0.005 to 0.012
C12000	99.90	0.004 to 0.012
C12200	99.9	0.015 to 0.040

<sup>A</sup> Oxygen in C10200 shall be 10 ppm max.

<sup>B</sup> Copper + silver + phosphorus.

5.3 When the copper UNS No. designation is specified, the material shall conform to the chemical requirements specified in Table 1.

5.4 These composition limits do not preclude the presence of other elements. By agreement between manufacturer or supplier and purchaser, limits may be established and analysis required for unnamed elements.

## 6. Temper

6.1 The standard tempers as prescribed in Classification B601, for products described in this specification are:

6.1.1 Annealed O61,

6.1.2 Light Drawn H55, and

6.1.3 Hard Drawn H80.

6.2 When pipe is required for bending, it shall be so specified in the purchase order, and the pipe shall be furnished in the temper agreed upon between the manufacturer or supplier and the purchaser.

## 7. Mechanical Property Requirements

7.1 *Tensile Strength Requirements:*

7.1.1 Product furnished under this specification shall conform to the tensile requirements prescribed in Table 2, when tested in accordance with Test Methods E8/E8M.

## 8. Performance Requirements

8.1 *Expansion Test:*

8.1.1 Pipe ordered in the annealed (O61) temper, selected for test, shall withstand an expansion of 25 % of the outside diameter when expanded in accordance with Test Method B153. The expanded pipe shall show no cracking or rupture visible to the unaided eye. Pipe ordered in the drawn tempers H55 or H80 are not subject to this test.

NOTE 1—The term “unaided eye,” as used herein, permits the use of corrective spectacles necessary to obtain normal vision.

8.2 *Flattening Test:*

8.2.1 As an alternative to the expansion test for pipe over 4 in. (102 mm) in diameter in the annealed temper, a flattening test in accordance with Test Method B968/B968M shall be performed.

8.3 *Microscopical Examination:*

8.3.1 The pipe shall be made from copper that is free of cuprous oxide as determined by microscopical examination in accordance with Method A of Test Methods B577 at a 75× magnification.

TABLE 2 Tensile Requirements

Temper Designation		Pipe Size Nominal or Standard, in.	Tensile Strength, min, ksi <sup>A</sup> (MPa) <sup>B</sup>	Yield Strength, <sup>C</sup> min, ksi <sup>A</sup> (MPa) <sup>B</sup>
Code	Name			
O61	annealed	all	30 (205)	9 (60) <sup>D</sup>
H80	hard drawn	1/8 –2, incl	45 (310)	40 (275)
H80	hard drawn	over 2	38 (260)	32 (220)
H55	light drawn	2–12, incl	36 (250)	30 (205)

<sup>A</sup> ksi = 1000 psi.

<sup>B</sup> See Appendix X1.

<sup>C</sup> At 0.5 % extension under load.

<sup>D</sup> Light-straightening operation is permitted.

8.3.2 When Copper UNS No. C12200 is supplied, microscopical examination for cuprous oxide is not required.

## 9. Other Requirements

### 9.1 Nondestructive Testing:

9.1.1 The material shall be tested in the final size but is permitted to be tested before the final anneal or heat treatment, when these thermal treatments are required, unless otherwise agreed upon by the manufacturer or supplier and purchaser.

9.1.2 The eddy current test, the hydrostatic test, or the pneumatic test shall be conducted on each tube at the manufacturer's option. The requirements of Section 12 do not apply.

9.2 *Eddy-Current Test*—Testing shall follow the procedures of Practice E243, except for determination of “end effect.” The material shall be passed through an eddy-current testing unit adjusted to provide information on the suitability of the material for the intended application.

9.2.1 Notch-depth standards rounded to the nearest 0.001 in. (0.025 mm) shall be 10 % of the nominal wall thickness. The notch depth tolerance shall be  $\pm 0.0005$  in. (0.013 mm). Alternatively, when a manufacturer uses speed-insensitive equipment that allows the selection of a maximum imbalance signal, a maximum imbalance signal of 0.3 % is permitted to be used.

9.2.2 Material that does not actuate the signaling device of the eddy-current test shall be considered as conforming to the requirements of this test. Material with discontinuities indicated by the testing unit is permitted to be re-examined or retested, at the option of the manufacturer, to determine whether the discontinuity is cause for rejection. Signals that are found to have been caused by minor mechanical damage, soil, or moisture shall not be cause for rejection of the material provided the dimensions of the material are still within prescribed limits and the material is suitable for its intended application.

9.3 *Hydrostatic Test*—The material shall stand, without showing evidence of leakage, an internal hydrostatic pressure sufficient to subject the material to a fiber stress of 6000 psi (41 MPa), determined by the following equation for thin hollow cylinders under tension. The material need not be tested at a hydrostatic pressure of over 1000 psi (6.9 MPa) unless so specified.

$$P = 2St/(D - 0.8t) \quad (1)$$

where:

- $P$  = hydrostatic pressure, psi (or MPa);  
 $t$  = wall thickness of the material, in. (or mm);  
 $D$  = outside diameter of the material in. (or mm); and  
 $S$  = allowable stress of the material, psi (or MPa).

9.4 *Pneumatic Test*—The material shall be subjected to an internal air pressure of 60 psi (415 kPa) minimum for 5 s without showing evidence of leakage. The test method used shall permit easy visual detection of any leakage, such as by having the material under water or by the pressure-differential method. Any evidence of leakage shall be cause for rejection.

9.5 *Purchases for U.S. Government*—If the product is purchased for agencies of the U.S. Government, when specified in the contract or purchase order, the product furnished shall conform to the conditions specified in the Supplementary Requirements of this specification.

## 10. Dimensions and Permissible Variations

10.1 For the purpose of determining conformance with the dimensional requirements prescribed in this specification, any measured value outside the limiting values for any dimensions shall be sufficient cause for rejection.

10.2 *Standard Dimensions, Wall Thickness, and Diameter Tolerances*—The standard dimensions, wall thickness, and diameter tolerances shall be in accordance with Table 3.

10.3 *Length and Length Tolerances*—The standard length of copper pipe is 12 ft (3.66 m) with a tolerance of  $\pm 1/2$  in. (13 mm).

### 10.4 Roundness:

10.4.1 For pipe of H (drawn) tempers in straight lengths, the roundness tolerances shall be as follows:

$t/d$ (ratio of Wall Thickness to Outside Diameter)	Roundness Tolerances as Percent of Outside Diameter (Expressed to the Nearest 0.001 in. (0.025 mm))
0.01 to 0.03, incl	1.5
Over 0.03 to 0.05, incl	1.0
Over 0.05 to 0.10, incl	0.8
Over 0.10	0.7

10.4.2 Compliance with the roundness tolerance shall be determined by taking measurements on the outside diameter only, irrespective of the manner in which the pipe dimensions are specified.

10.4.3 The deviation from roundness is measured as the difference between major and minor diameters as determined at any one cross section of the tube.

10.5 *Squareness of Cut*—The departure from squareness of the end of any pipe shall not exceed the following:

Outside Diameter, in. (mm)	Tolerance
Up to $5/8$ (15.9), incl	0.010 in. (0.25 mm)
Over $5/8$ (15.9)	0.016 in./in. (0.016 mm/mm) of diameter

10.6 *Straightness Tolerance*—For pipe of H (drawn) tempers of nominal pipe sizes from  $1/4$  to 12 in. inclusive, the maximum curvature (depth of arc) shall not exceed  $1/2$  in. (13 mm) in any 10 ft portion of the total length. For H temper pipe of other sizes, and for the O61 (annealed) temper, no numerical values are established; however, the straightness of the pipe shall be suitable for the intended application.

## 11. Workmanship, Finish, and Appearance

11.1 The product shall be free of defects, but blemishes of a nature that do not interfere with the intended application are acceptable. It shall be well cleaned and free of dirt.

## 12. Sampling

12.1 *Sampling*—The lot size, portion size, and selection of sample pieces shall be as follows:

TABLE 3 Standard Dimensions, Weights, and Tolerances

NOTE 1—All tolerances plus and minus except as otherwise indicated.

Nominal or Standard Pipe Size, in.	Outside Diameter, in. (mm)	Average Outside Diameter Tolerance, <sup>A</sup> in. (mm) All Minus	Wall Thickness, in. (mm)	Tolerance, <sup>B</sup> in. (mm)	Theoretical Weight, lb/ft (kg/m)
Regular					
1/8	0.405 (10.3)	0.004 (0.10)	0.062 (1.57)	0.004 (0.10)	0.259 (0.385)
1/4	0.540 (13.7)	0.004 (0.10)	0.082 (2.08)	0.005 (0.13)	0.457 (0.680)
3/8	0.675 (17.1)	0.005 (0.13)	0.090 (2.29)	0.005 (0.13)	0.641 (0.954)
1/2	0.840 (21.3)	0.005 (0.13)	0.107 (2.72)	0.006 (0.15)	0.955 (1.42)
3/4	1.050 (26.7)	0.006 (0.15)	0.114 (2.90)	0.006 (0.15)	1.30 (1.93)
1	1.315 (33.4)	0.006 (0.15)	0.126 (3.20)	0.007 (0.18)	1.82 (2.7)
1 1/4	1.660 (42.2)	0.006 (0.15)	0.146 (3.71)	0.008 (0.20)	2.69 (4.00)
1 1/2	1.900 (48.3)	0.006 (0.15)	0.150 (3.81)	0.008 (0.20)	3.20 (4.76)
2	2.375 (60.3)	0.008 (0.20)	0.156 (3.96)	0.009 (0.23)	4.22 (6.28)
2 1/2	2.875 (73.0)	0.008 (0.20)	0.187 (4.75)	0.010 (0.25)	6.12 (9.11)
3	3.500 (88.9)	0.010 (0.25)	0.219 (5.56)	0.012 (0.30)	8.76 (13.0)
3 1/2	4.000 (102)	0.010 (0.25)	0.250 (6.35)	0.013 (0.33)	11.4 (17.0)
4	4.500 (114)	0.012 (0.30)	0.250 (6.35)	0.014 (0.36)	12.9 (19.2)
5	5.562 (141)	0.014 (0.36)	0.250 (6.35)	0.014 (0.36)	16.2 (24.1)
6	6.625 (168)	0.016 (0.41)	0.250 (6.35)	0.014 (0.36)	19.4 (28.9)
8	8.625 (219)	0.020 (0.51)	0.312 (7.92)	0.022 (0.56)	31.6 (47.0)
10	10.750 (273)	0.022 (0.56)	0.365 (9.27)	0.030 (0.76)	46.2 (68.7)
12	12.750 (324)	0.024 (0.61)	0.375 (9.52)	0.030 (0.76)	56.5 (84.1)
Extra Strong					
1/8	0.405 (10.3)	0.004 (0.10)	0.100 (2.54)	0.006 (0.15)	0.371 (0.552)
1/4	0.540 (13.7)	0.004 (0.10)	0.123 (3.12)	0.007 (0.18)	0.625 (0.930)
3/8	0.675 (17.1)	0.005 (0.13)	0.127 (3.23)	0.007 (0.18)	0.847 (1.26)
1/2	0.840 (21.3)	0.005 (0.13)	0.149 (3.78)	0.008 (0.20)	1.25 (1.86)
3/4	1.050 (26.7)	0.006 (0.15)	0.157 (3.99)	0.009 (0.23)	1.71 (2.54)
1	1.315 (33.4)	0.006 (0.15)	0.182 (4.62)	0.010 (0.25)	2.51 (3.73)
1 1/4	1.660 (42.2)	0.006 (0.15)	0.194 (4.93)	0.010 (0.25)	3.46 (5.15)
1 1/2	1.900 (48.3)	0.006 (0.15)	0.203 (5.16)	0.011 (0.28)	4.19 (6.23)
2	2.375 (60.3)	0.008 (0.20)	0.221 (5.61)	0.012 (0.30)	5.80 (8.63)
2 1/2	2.875 (73.0)	0.008 (0.20)	0.230 (5.71)	0.015 (0.38)	8.85 (13.2)
3	3.500 (88.9)	0.010 (0.25)	0.304 (7.72)	0.016 (0.41)	11.8 (17.6)
3 1/2	4.000 (102)	0.010 (0.25)	0.321 (8.15)	0.017 (0.43)	14.4 (21.4)
4	4.500 (114)	0.012 (0.30)	0.341 (8.66)	0.018 (0.46)	17.3 (25.7)
5	5.562 (141)	0.014 (0.36)	0.375 (9.52)	0.019 (0.48)	23.7 (35.3)
6	6.625 (168)	0.016 (0.41)	0.437 (11.1)	0.027 (0.69)	32.9 (49.0)
8	8.625 (219)	0.020 (0.51)	0.500 (12.7)	0.035 (0.89)	49.5 (73.7)
10	10.750 (273)	0.022 (0.56)	0.500 (12.7)	0.040 (1.0)	62.4 (92.9)

<sup>A</sup> The average outside diameter of a tube is the average of the maximum and minimum outside diameters as determined at any one cross section of the pipe.<sup>B</sup> Maximum deviation at any one point.

### 12.1.1 Lot Size—The lot size shall be as follows:

Pipe Size, in.	Lot Weight, lb (kg)
Up to 1 1/2, incl	5 000 (2270) or fraction thereof
Over 1 1/2 to 4, incl	10 000 (4550) or fraction thereof
Over 4	40 000 (18 100) or fraction thereof

### 12.1.2 Portion Size—Sample pieces shall be taken for test purposes from each lot according to the following schedule:

Number of Pieces in Lot	Number of Sample Pieces to be Taken <sup>A</sup>
1 to 50	1
51 to 200	2
201 to 1500	3
Over 1500	0.2 % of total number of pieces in the lot, but not to exceed ten sample pieces

<sup>A</sup> Each sample piece shall be taken from a separate tube.

## 13. Number of Tests and Retests

13.1 *Chemical Analysis*—Samples for chemical analysis shall be taken in accordance with Practice E255. Drillings, millings, and so forth shall be taken in approximately equal weight from each of the sample pieces selected in accordance with 12.1.2 and combined into one composite sample. The

minimum weight of the composite sample that is to be divided into three equal parts shall be 150 g.

13.1.1 Instead of sampling in accordance with Practice E255, the manufacturer shall have the option of determining conformance to chemical composition as follows: conformance shall be determined by the manufacturer by analyzing samples taken at the time the castings are poured or samples taken from the semifinished product. If the manufacturer determines the chemical composition of the material during the course of manufacture, he shall not be required to sample and analyze the finished product. The number of samples taken for determination of chemical composition shall be as follows:

13.1.1.1 When samples are taken at the time the castings are poured, at least one sample shall be taken for each group of castings poured simultaneously from the same source of molten metal.

13.1.1.2 When samples are taken from the semifinished product, a sample shall be taken to represent each 10 000 lb (4550 kg) or fraction thereof, except that not more than one sample shall be required per piece.

13.1.1.3 Because of the discontinuous nature of the processing of castings into wrought products, it is not practical to identify specific casting analysis with a specific quantity of finished material.

13.1.1.4 In the event that heat identification or traceability is required, the purchaser shall specify the details desired.

13.2 *Retests:*

13.2.1 If any test specimen shows defective machining or develops flaws, it shall be discarded and another specimen substituted.

13.2.2 If a bend test specimen fails because of conditions of bending more severe than required by the specification, a retest shall be permitted on a new sample piece or on the remaining portion of the first sample piece.

13.2.3 If the results of the test on one of the specimens fail to meet the specified requirements, two additional specimens shall be taken from different sample pieces and tested. The results of the tests on both of these specimens shall meet the specified requirements. Failure of more than one specimen to meet the specified requirements for a particular property shall be cause for rejection of the entire lot.

13.2.4 If the chemical analysis fails to conform to the specified limits, analysis shall be made on a new composite sample prepared from additional pieces selected in accordance with 12.1. The results of this retest shall comply with the specified requirements.

14. Test Methods

14.1 *Chemical Analysis:*

14.1.1 In cases of disagreement, test methods for chemical analysis shall be subject to agreement between the manufacturer or supplier and the purchaser. The following table is a list of published methods, some of which may no longer be viable, which along with others not listed, may be used subject to agreement:

Test	ASTM Designation <sup>A</sup>
Chemical analysis	B170, <sup>B</sup> E58, E62, E478

<sup>A</sup> See 2.1.

<sup>B</sup> Reference to Specification B170 is to the suggested chemical methods in the annex thereof. When Committee E01 has tested and published methods for assaying the low-level impurities in copper, the Specification B170 annex will be eliminated.

14.1.2 Test method(s) to be followed for the determination of element(s) resulting from contractual or purchase order agreement shall be as agreed upon between the manufacturer or supplier and purchaser.

14.2 The product furnished shall conform to the specified requirements when subjected to test in accordance with the following applicable test methods:

Test	ASTM Designation <sup>A</sup>
Tensile Strength	E8/E8M
Expansion (pin test)	B153
Eddy current	E243
Microscopical Examination	B577
Flattening Test	B968/B968M

<sup>A</sup> See 2.1.

14.3 *Tensile Strength Requirements:*

14.3.1 Tensile test specimens shall be of the full section of the pipe and shall conform to the requirements of the Specimens for Pipe and Tube section of Test Methods E8/E8M unless the limitations of the testing machine preclude the use of such a specimen. Test specimens conforming to Type No. 1 of Fig. 13, Tension Test Specimens for Large-Diameter Tubular Products, of Test Methods E8/E8M is permitted to be used when a full-section specimen cannot be tested.

14.3.2 Whenever tensile test results are obtained from both full-size and machined test specimens and they differ, the results obtained from full-size test specimens shall be used to determine conformance to the specification requirements.

14.3.3 Tensile test results on material covered by this specification are not seriously affected by variations in speed of testing. A considerable range of testing speed is permissible; however, it is recommended that the rate of stressing to the yield strength not exceed 100 ksi (700 MPa)/min. Above the yield strength, it is recommended that the movement per minute of the testing machine head under load not exceed 0.5 in./in. (0.5 mm/mm) of gage length (or distance between grips for full-section specimens).

15. Significance of Numerical Limits

15.1 For purposes of determining compliance with the specified limits for requirements of the properties listed in the following table, an observed value or a calculated value shall be rounded as indicated in accordance with the rounding method of Practice E29.

Property	Rounded Unit for Observed or Calculated Value
Chemical composition	nearest unit in the last right-hand place of figures of the specified limit
Tensile strength Yield strength	nearest ksi (nearest 5 MPa)

16. Inspection

16.1 The manufacturer or supplier shall inspect and make tests necessary to verify the furnished product conforms to the specification requirements.

16.2 Source inspection of the product by the purchaser may be agreed upon between the manufacturer or supplier and the purchaser as part of the purchase order. In such case, the nature of the facilities needed to satisfy the inspector representing the purchaser that the product is being furnished in accordance with the specification shall be included in this agreement. All testing and inspection shall be conducted so as not to interface unnecessarily with the operation of the works.

16.3 When mutually agreed upon, the manufacturer or supplier and purchaser shall conduct the final inspection simultaneously.

17. Rejection and Rehearing

17.1 *Rejection:*

17.1.1 Product that fails to conform to the specification requirements when tested by the purchaser or purchaser's agent shall be subject to rejection.

17.1.2 Rejection shall be reported to the manufacturer or supplier promptly. In addition, a written notification of rejection shall follow.

17.1.3 In case of dissatisfaction with results of the test upon which rejection is based, the manufacturer or supplier shall have the option to make claim for a rehearing.

#### 17.2 Rehearing:

17.2.1 As a result of product rejection, the manufacturer or supplier shall have the option to make claim for a retest to be conducted by the manufacturer or supplier and the purchaser. Samples of the rejected product shall be taken in accordance with the product specification and subjected to test by both parties using the test method(s) specified in the product specification or, alternately, upon agreement of both parties, an independent laboratory may be selected for the test(s) using the test method(s) specified in the product specification.

### 18. Certification

18.1 The purchaser shall be furnished certification that samples representing each lot have been tested and inspected as directed in this specification and the requirements have been met.

18.2 DELETED

### 19. Test Report

19.1 A report of test results shall be furnished.

### 20. Packaging and Package Marking

#### 20.1 Packaging:

20.1.1 The product shall be separated by size, composition, and temper, and prepared for shipment by common carrier in such a manner as to afford protection from the normal hazards of transportation.

#### 20.2 Package Marking:

20.2.1 Each package shall be legibly marked with the metal or alloy designation, temper, size, gross and net weight, total length or piece count, or both, and name of supplier. Upon agreement between the purchaser and supplier, the purchase order number shall be indicated on each package or on the shipping documents.

20.2.2 When specified in the purchase order or contract, the product specification number shall be shown.

### 21. Keywords

21.1 copper pipe; extra strong; regular; standard sizes ; UNS No. C10200; UNS No. C10300; UNS No. C10800; UNS No. C12000; UNS No. C12200

## SUPPLEMENTARY REQUIREMENTS

### S1. Scope

S1.1 The following supplementary requirements shall apply only when specified by the purchaser in the inquiry, contract, or order, for agencies of the U.S. Government.

### S2. Referenced Documents

S2.1 The following documents of the issue in effect on date of material purchase form a part of this specification to the extent referenced herein:

#### S2.1.1 ASTM Standard:

B900 Practice for Packaging of Copper and Copper Alloy Mill Products for U.S. Government Agencies

#### S2.1.2 Federal Standard:

Fed. Std. No. 123 Marking for Shipment (Civil Agencies)

#### S2.1.3 Military Standards:

MIL-STD-129 Marking for Shipment and Storage

MIL-STD-2073/1 Standard Practice for Military Packaging

#### S2.1.4 SAE Standard:

AMS-STD-185 Identification Marking of Copper and Copper-Base Alloy Mill Products

### S3. Quality Assurance

S3.1 *Responsibility for Inspection:*

S3.1.1 Unless otherwise specified in the contract or purchase order, the manufacturer is responsible for the performance of all inspection and test requirements specified. Except as otherwise specified in the contract or purchase order, the manufacturer shall use his own or any other suitable facilities for the performance of the inspection and test requirements unless disapproved by the purchaser at the time the order is placed. The purchaser shall have the right to perform any of the inspections or tests set forth when such inspections and tests are deemed necessary to assure that the material conforms to prescribed requirements.

### S4. Identification Marking

S4.1 All material shall be properly marked for identification in accordance with AMS-STD-185 except that the ASTM specification number and the alloy number shall be used.

### S5. Preparation for Delivery

#### S5.1 Preservation, Packaging, Packing:

S5.1.1 *Military Agencies*—The material shall be separated by size, composition, grade, or class and shall be preserved and packaged, Level A or C, and packed, Level A, B, or C, as specified in the contract or purchase order, in accordance with the requirements of Practice B900.

S5.1.2 *Civil Agencies*—The requirements of MIL-STD-2073 shall be referenced for definitions of the various levels of packaging protection.

**TABLE S6.1 Part or Identifying Numbers**

B42	XXXXXX	XXX	-XX	X	X	XXX	X
			Size (See Table 3)			Length	
Document Identifier	Alloy (See Table 1)	Temper (See 6.1)	inches	eighths of an inch	Wall thickness (R = regular, S = extra strong)	inches	eighths of an inch

**S5.2 Marking:**

S5.2.1 *Military Agencies*—In addition to any special marking required by the contract or purchase order, marking for shipment shall be in accordance with MIL-STD-129.

S5.2.2 *Civil Agencies*—In addition to any special marking required by the contract or purchase order, marking for shipment shall be in accordance with Fed. Std. No. 123.

**S6. Part or Identifying Numbers (PINs)**

S6.1 Part numbers are essential to maintain the integrity of the Department of Defense cataloging system as multiple National Stock Numbers (NSN) exist for this product. The

following information is provided for cross-reference purposes. The pipe previously described in WW-P-377 and MS14302 corresponds to ASTM B42 copper pipe of copper UNS No. C12000 with a regular wall thickness.

S6.2 Part identifying numbers, for government use, shall be formulated by selecting from the options in this specification as shown in Table S6.1.

S6.3 An example of a PIN follows: A part identifying number of B42C12000H80-030R1264 indicates an ASTM B42 pipe of copper UNS No. C12000 in the hard drawn (H80) temper, 3 in. standard pipe size, regular wall thickness, and it is 10 ft 6½ in. (3213 mm) in length.

**APPENDIX**

**(Nonmandatory Information)**

**X1. METRIC EQUIVALENTS**

X1.1 The SI unit for strength properties now shown is in accordance with the International System of Units (SI). The derived SI unit for force is the newton (N), which is defined as that force which when applied to a body having a mass of one kilogram gives it an acceleration of one metre per second squared ( $N = kg \cdot m/s^2$ ). The derived SI unit for pressure or

stress is the newton per square metre ( $N/m^2$ ), which has been named the pascal (Pa) by the General Conference on Weights and Measures. Since  $1 \text{ ksi} = 6\,894\,757 \text{ Pa}$ , the metric equivalents are expressed as megapascal (MPa), which is the same as  $MN/m^2$  and  $N/mm^2$ .

## SPECIFICATION FOR SEAMLESS RED BRASS PIPE, STANDARD SIZES



**SB-43**

(Identical with ASTM Specification B43-20 except that certification and mill test reports have been made mandatory, and nondestructive testing is required for all diameters.)

ASMENORMDOC.COM : Click to view the full PDF of ASME BPVC.II.B (ASME BPVC Section II part B) 2025

## Specification for Seamless Red Brass Pipe, Standard Sizes

### 1. Scope

1.1 This specification establishes requirements for seamless red brass (Copper Alloy UNS No. C23000) pipe in nominal pipe sizes, both regular and extra-strong. In the annealed temper (O61), the pipe is suitable for use in plumbing, boiler feed lines, and for similar purposes. In the drawn general purpose temper (H58), the pipe is suitable for architectural applications, such as guard railings and stair hand railings.

1.2 *Units*—The values stated in inch-pound units are to be regarded as standard. The values given in parentheses are mathematical conversions to SI units that are provided for information only and are not considered standard.

1.3 The following hazard caveat pertains only to the test method portion, 9.1.1, of this specification. *This standard does not purport to address all of the safety concerns, if any, associated with its use. It is the responsibility of the user of this standard to establish appropriate safety, health, and environmental practices and determine the applicability of regulatory limitations prior to use.*

1.4 **Warning**—Mercury has been designated by many regulatory agencies as a hazardous substance that can cause serious medical issues. Mercury, or its vapor, has been demonstrated to be hazardous to health and corrosive to materials. Use caution when handling mercury and mercury-containing products. See the applicable product Safety Data Sheet (SDS) for additional information. The potential exists that selling mercury or mercury-containing products, or both, is prohibited by local or national law. Users must determine legality of sales in their location. (See 9.2.)

1.5 *This international standard was developed in accordance with internationally recognized principles on standardization established in the Decision on Principles for the Development of International Standards, Guides and Recommendations issued by the World Trade Organization Technical Barriers to Trade (TBT) Committee.*

### 2. Referenced Documents

#### 2.1 ASTM Standards:

- B153 Test Method for Expansion (Pin Test) of Copper and Copper-Alloy Pipe and Tubing
- B154 Test Method for Mercurous Nitrate Test for Copper Alloys
- B601 Classification for Temper Designations for Copper and Copper Alloys—Wrought and Cast
- B846 Terminology for Copper and Copper Alloys
- B858 Test Method for Ammonia Vapor Test for Determining Susceptibility to Stress Corrosion Cracking in Copper Alloys
- B900 Practice for Packaging of Copper and Copper Alloy Mill Products for U.S. Government Agencies
- B950 Guide for Editorial Procedures and Form of Product Specifications for Copper and Copper Alloys
- B968/B968M Test Method for Flattening of Copper and Copper-Alloy Pipe and Tube
- E8/E8M Test Methods for Tension Testing of Metallic Materials
- E29 Practice for Using Significant Digits in Test Data to Determine Conformance with Specifications
- E112 Test Methods for Determining Average Grain Size
- E243 Practice for Electromagnetic (Eddy Current) Examination of Copper and Copper-Alloy Tubes
- E255 Practice for Sampling Copper and Copper Alloys for the Determination of Chemical Composition
- E478 Test Methods for Chemical Analysis of Copper Alloys
- E527 Practice for Numbering Metals and Alloys in the Unified Numbering System (UNS)

2.2 ASME Code:  
ASME Boiler and Pressure Vessel Code

3. Terminology

3.1 For definitions of terms related to copper and copper alloys, refer to Terminology B846.

4. Ordering Information

4.1 Include the following specified choices when placing orders for product under this specification as applicable:

- 4.1.1 ASTM designation and year of issue;
- 4.1.2 Temper (see Temper section);
- 4.1.3 Pipe size, regular or extra-strong (see Table 1);
- 4.1.4 Length (see 11.3);
- 4.1.5 Quantity—total weight or total length of each size; and
- 4.1.6 Intended application.
- 4.2 The following options are available but may not be included unless specified at the time of placing the order when required:
  - 4.2.1 DELETED
  - 4.2.2 DELETED
  - 4.2.3 DELETED

TABLE 1 Standard Dimensions, Weights, and Tolerances

NOTE 1—All tolerances are plus and minus except as otherwise indicated.

Nominal or Standard Pipe Size, in.	Outside Diameter, in. (mm)	Average Outside Diameter Tolerances, <sup>A</sup> in. (mm) All Minus	Wall Thickness, in. (mm)	Tolerance, <sup>B</sup> in. (mm)	Theoretical Weight, lb/ft (kg/m)
Regular					
1/8	0.405 (10.3)	0.004 (0.10)	0.062 (1.57)	0.004 (0.10)	0.253 (0.376)
1/4	0.540 (13.7)	0.004 (0.10)	0.082 (2.08)	0.005 (0.13)	0.447 (0.665)
3/8	0.675 (17.1)	0.005 (0.13)	0.090 (2.29)	0.005 (0.13)	0.627 (0.933)
1/2	0.840 (21.3)	0.005 (0.13)	0.107 (2.72)	0.006 (0.15)	0.934 (1.39)
3/4	1.050 (26.7)	0.006 (0.15)	0.114 (2.90)	0.006 (0.15)	1.27 (1.89)
1	1.315 (33.4)	0.006 (0.15)	0.126 (3.20)	0.007 (0.18)	1.78 (2.65)
1 1/4	1.660 (42.2)	0.006 (0.15)	0.146 (3.71)	0.008 (0.20)	2.63 (3.91)
1 1/2	1.900 (48.3)	0.006 (0.15)	0.150 (3.81)	0.008 (0.20)	3.13 (4.66)
2	2.375 (60.3)	0.008 (0.20)	0.156 (3.96)	0.009 (0.23)	4.12 (6.13)
2 1/2	2.875 (73.0)	0.008 (0.20)	0.187 (4.75)	0.010 (0.25)	5.99 (8.91)
3	3.500 (88.9)	0.010 (0.25)	0.219 (5.56)	0.012 (0.30)	8.56 (12.7)
3 1/2	4.000 (102)	0.010 (0.25)	0.250 (6.35)	0.013 (0.33)	11.2 (16.7)
4	4.500 (114)	0.012 (0.30)	0.250 (6.35)	0.014 (0.36)	12.7 (18.9)
5	5.562 (141)	0.014 (0.36)	0.250 (6.35)	0.014 (0.36)	15.8 (23.5)
6	6.625 (168)	0.016 (0.41)	0.250 (6.35)	0.014 (0.36)	19.0 (28.3)
8	8.625 (219)	0.020 (0.51)	0.312 (7.92)	0.022 (0.56)	30.9 (46.0)
10	10.750 (273)	0.022 (0.56)	0.365 (9.27)	0.030 (0.76)	45.2 (67.3)
12	12.750 (324)	0.024 (0.61)	0.375 (9.52)	0.030 (0.76)	55.3 (82.3)
Extra Strong					
1/8	0.405 (10.3)	0.004 (0.10)	0.100 (2.54)	0.006 (0.15)	0.363 (0.540)
1/4	0.540 (13.7)	0.004 (0.10)	0.123 (3.12)	0.007 (0.18)	0.611 (0.909)
3/8	0.675 (17.1)	0.005 (0.13)	0.127 (3.23)	0.007 (0.18)	0.829 (1.23)
1/2	0.840 (21.3)	0.005 (0.13)	0.149 (3.78)	0.008 (0.20)	1.23 (1.83)
3/4	1.050 (26.7)	0.006 (0.15)	0.157 (3.99)	0.009 (0.23)	1.67 (2.48)
1	1.315 (33.4)	0.006 (0.15)	0.182 (4.62)	0.010 (0.25)	2.46 (3.66)
1 1/4	1.660 (42.2)	0.006 (0.15)	0.194 (4.93)	0.010 (0.25)	3.39 (5.04)
1 1/2	1.900 (48.3)	0.006 (0.15)	0.203 (5.16)	0.011 (0.28)	4.10 (6.10)
2	2.375 (60.3)	0.008 (0.20)	0.221 (5.61)	0.012 (0.30)	5.67 (8.44)
2 1/2	2.875 (73.0)	0.008 (0.20)	0.280 (7.11)	0.015 (0.38)	8.66 (12.9)
3	3.500 (88.9)	0.010 (0.25)	0.304 (7.72)	0.016 (0.41)	11.6 (17.3)
3 1/2	4.000 (102)	0.010 (0.25)	0.321 (8.15)	0.017 (0.43)	14.1 (21.0)
4	4.500 (114)	0.012 (0.30)	0.341 (8.66)	0.018 (0.46)	16.9 (25.1)
5	5.562 (141)	0.014 (0.36)	0.375 (9.52)	0.019 (0.48)	23.2 (34.5)
6	6.625 (168)	0.016 (0.41)	0.437 (11.1)	0.027 (0.69)	32.2 (47.9)
8	8.625 (219)	0.020 (0.51)	0.500 (12.7)	0.035 (0.89)	48.4 (72.0)
10	10.750 (273)	0.022 (0.56)	0.500 (12.7)	0.040 (1.0)	61.1 (90.9)

<sup>A</sup> The average outside diameter of a tube is the average of the maximum and minimum outside diameters as determined at any one cross section of the pipe.  
<sup>B</sup> Maximum deviation at any one point.

- 4.2.4 Hydrostatic test, if required (see 10.3);  
 4.2.5 Pneumatic test, if required (see 10.4);  
 4.2.6 Residual stress test, if required (Performance Requirements section);  
 4.2.6.1 Ammonia Vapor Test or Mercurous Nitrate Test;  
 4.2.6.2 For Ammonia Vapor Test, pH value other than 10;  
 4.2.7 Inclusion of the specification number on the packaging unit (see 19.2); and  
 4.2.8 If product is purchased for agencies of the U.S. Government (see the Supplementary Requirements section of this specification) for additional requirements, if specified.

## 5. Chemical Composition

5.1 The material shall conform to the following chemical composition requirements:

Copper, %	84.0 to 86.0
Lead, max, %	0.05
Iron, max, %	0.05
Zinc	remainder

5.1.1 Results of analysis on a product (check) sample shall conform to the composition requirements within the permitted analytical variance specified above.

5.2 These composition limits do not preclude the presence of other elements. By agreement between the manufacturer or supplier and purchaser, limits may be established and analysis required for unnamed elements.

5.2.1 For copper alloys in which zinc is listed as “remainder,” either copper or zinc may be taken as the difference between the sum of results of all other elements determined and 100 %.

5.2.1.1 When all the elements in the table in 5.1 are determined, the sum of the results shall be 99.8 % minimum.

## 6. Temper

6.1 All pipe shall normally be furnished in the O61 (annealed) (see Classification B601) temper.

6.2 The pipe is permitted to be furnished in the H58 (drawn general purpose) temper, if agreed upon between the manufacturer and the purchaser. (See Table 2.)

## 7. Grain Size for Annealed Temper

7.1 Grain size shall be the standard requirement for all product in the annealed temper.

7.2 Acceptance or rejection based upon grain size shall depend only on the average grain size of a test specimen taken from each of two sample portions, and each specimen shall be within the limits prescribed in 7.3 when determined in accordance with Test Methods E112.

TABLE 2 Tensile Requirements

Temper Designation		Tensile Strength, min.	Yield Strength <sup>A</sup> , min.	Elongation in 2-in. min. %
Code	Name	ksi (MPa)	ksi (MPa)	
O61	Annealed	40.0 (275)	12.0 (85)	35
H58	Drawn general purpose	44.0 (300)	18.0 (125)	...

<sup>A</sup> At 0.5 % extension under load.

7.3 In the O61 (annealed) temper, the degree of annealing shall be sufficient to produce complete recrystallization with an average grain size not in excess of 0.050 mm.

## 8. Mechanical Property Requirements

8.1 Product furnished under this specification shall conform to the tensile, yield, and elongation requirements (where required) prescribed in Table 2, when tested in accordance with Test Methods E8/E8M<sup>1</sup>

## 9. Performance Requirements

### 9.1 Expansion Test:

9.1.1 Specimens in the O61 (annealed) temper shall withstand an expansion of 25 % of the outside diameter when expanded in accordance with Test Method B153. The expanded pipe shall show no cracking or rupture visible to the unaided eye. Pipe ordered in the drawn (H) condition is not subject to this test.

NOTE 1—The term “unaided eye,” as used herein, permits the use of corrective spectacles necessary to obtain normal vision.

9.1.2 As an alternative to the expansion test for pipe over 4 in. (102 mm) in diameter in the O61 (annealed) condition, a flattening test in accordance with Test Method B968/B968M shall be performed.

### 9.2 Residual Stress Test:

9.2.1 When specified in the contract or purchase order, product of the O61 (annealed) shall be tested for residual stress according to the requirements of Test Method B154 or Test Method B858, and show no signs of cracking.

**Warning**—Mercury is a definite health hazard. With the Mercurous Nitrate Test, equipment for the detection and removal of mercury vapor produced in volatilization, and the use of protective gloves is recommended.

NOTE 2—A residual stress test provides information about the adequacy of the stress relief of the material. Tube straightening is a method of mechanical stress relief. Stress relief annealing is a method of thermal stress relief.

## 10. Other Requirements

10.1 *Nondestructive Testing*—The material shall be tested in the final size but is permitted to be tested prior to the final anneal or heat treatment, when these thermal treatments are required, unless otherwise agreed upon by the manufacturer or supplier and purchaser.

10.1.1 Either the eddy current, hydrostatic, or pneumatic test shall be conducted on each tube at the manufacturer’s option. The sampling requirements of Section 13 do not apply.

10.2 *Eddy-Current Test*—Testing shall follow the procedures of Practice E243 except for determination of “end effect.” The material shall be passed through an eddy-current testing unit adjusted to provide information on the suitability of the material for the intended application.

10.2.1 Notch-depth standards rounded to the nearest 0.001 in. (0.025 mm) shall be 10 % of the nominal wall thickness. The notch depth tolerances shall be  $\pm 0.0005$  in. (0.013 mm). Alternatively, when a manufacturer uses speed

insensitive equipment that allows the selection of a maximum imbalance signal, a maximum imbalance signal of 0.3 % is permitted to be used.

10.2.2 Material that does not actuate the signaling device of the eddy-current test shall be considered as conforming to the requirements of this test. Material with discontinuities indicated by the testing unit is permitted to be reexamined or retested, at the option of the manufacturer, to determine whether the discontinuity is cause for rejection. Signals that are found to have been caused by minor mechanical damage, soil or moisture shall not be cause for rejection of the material provided the dimensions of the material are still within prescribed limits and the material is suitable for its intended application.

10.3 *Hydrostatic Test*—The material shall stand, without showing evidence of leakage, an internal hydrostatic pressure sufficient to subject the material to a fiber stress of 6000 psi (41 MPa), determined by the following equation for thin hollow cylinders under tension. The material need not be tested at a hydrostatic pressure of over 1000 psi (6.9 MPa) unless so specified.

$$P = 2St/(D - 0.8t)$$

where:

- $P$  = hydrostatic pressure, psi (or MPa);  
 $t$  = wall thickness of the material, in. (or mm);  
 $D$  = outside diameter of the material in. (or mm); and  
 $S$  = allowable stress of the material, psi (or MPa).

10.3.1 For material less than ½ in. (12.7 mm) in outside diameter and less than 0.060 in. (1.5 mm) in wall thickness, the test is permitted to be made at the option of the manufacturer by pneumatically testing to the requirements of 10.4.

10.4 *Pneumatic Test*—The material shall be subjected to an internal air pressure of 60 psi (415 kPa) minimum for 5 s without showing evidence of leakage. The test method used shall permit easy visual detection of any leakage, such as by having the material under water or by the pressure-differential method. Any evidence of leakage shall be cause for rejection.

## 11. Dimensions and Permissible Variations

11.1 For the purpose of determining conformance with the dimensional requirements prescribed in this specification, any measured value outside the limiting values for any dimensions may be cause for rejection.

11.2 *Standard Dimensions, Wall Thickness, and Diameter Tolerances*—The standard dimensions, wall thickness, and diameter tolerances shall be in accordance with Table 1.

11.3 *Length and Length Tolerances*—The standard length of red brass pipe is 12 ft (3.66 m) with a tolerance of ±½ in. (13 mm).

11.4 *Squareness of Cut*—The departure from squareness of the end of any pipe shall not exceed the following:

Outside Diameter, in. (mm)	Tolerance
Up to ¾ (15.9), incl	0.010 in. (0.25 mm)
Over ¾ (15.9)	0.016 in./in. (0.016 mm/mm) of diameter

11.5 *Roundness*—The roundness tolerance for straight length tubes with a wall thickness to outside diameter ratio of 0.01 to 0.05 (inclusive) shall be 6 % of the nominal outside diameter. For tubes with a wall thickness to outside diameter ratio over 0.05, the roundness tolerance shall be 3 % of the nominal outside diameter.

11.5.1 The measurement for roundness shall be made from the outside diameter. The deviation from roundness is measured as the difference between the major and minor diameters as determined at any one cross section of the tube. The major and minor diameters are the diameters of two concentric circles just enclosing the outside surface of the tube at the cross section.

11.6 *Straightness Tolerance*—For pipe of H58 (drawn general purpose) temper of Nominal Pipe Sizes from ¼ to 12 in. inclusive, the maximum curvature (depth of arc) shall not exceed ½ in. (13 mm) in any 10 ft (3048 mm) portion of the total length. For H58 temper pipe of other sizes, and for the O61 (annealed) temper, no numerical values are established; however, the straightness of the pipe shall be suitable for the intended application.

## 12. Workmanship, Finish, and Appearance

12.1 The product shall be free of defects, but blemishes of a nature that do not interfere with normal commercial applications are acceptable. It shall be well cleaned and free of dirt.

## 13. Sampling

13.1 *Sampling*—The lot size, portion size, and selection of sample pieces shall be as follows:

13.1.1 *Lot Size*—The lot size shall be as follows:

Pipe Size, in.	Lot Weight, lb (kg)
Up to 1½, incl	5 000 (2270) or fraction thereof
Over 1½ to 4, incl	10 000 (4550) or fraction thereof
Over 4	40 000 (18 100) or fraction thereof

13.1.2 *Portion Size*—Sample pieces shall be taken for test purposes from each lot according to the following schedule:

Number of Pieces in Lot	Number of Sample Pieces to be Taken <sup>A</sup>
1 to 50	1
51 to 200	2
201 to 1500	3
Over 1500	0.2 % of total number of pieces in the lot, but not to exceed 10 sample pieces

<sup>A</sup> Each sample piece shall be taken from a separate tube.

13.1.3 *Sampling for Visual and Dimensional Examination*—Minimum sampling for visual and dimensional examination shall be as follows:

Lot size (Pieces/lot)	Sample size
2 to 8	Entire lot
9 to 90	8
91 to 150	12
151 to 280	19
281 to 500	21
501 to 1200	27
1201 to 3200	35
3201 to 100 000	38
10 001 to 350 000	46

In all cases, the acceptance number is zero and the rejection number is one. Rejected lots are permitted to be screened and resubmitted for visual and dimensional examination. All defective items shall be replaced with acceptable items prior to lot acceptance.

#### 14. Number of Tests and Retests

14.1 *Chemical Analysis*—Samples for chemical analysis shall be taken in accordance with Practice E255. Drillings, millings, etc., shall be taken in approximately equal weight from each of the sample pieces selected in accordance with 13.1.2 and combined into one composite sample. The minimum weight of the composite sample that is to be divided into three equal parts shall be 150 g.

14.1.1 Instead of sampling in accordance with Practice E255, the manufacturer shall have the option of determining conformance to chemical composition as follows: Conformance shall be determined by the manufacturer by analyzing samples taken at the time the castings are poured or samples taken from the semi-finished product. If the manufacturer determines the chemical composition of the material during the course of manufacture, he shall not be required to sample and analyze the finished product. The number of samples taken for determination of chemical composition shall be as follows:

14.1.1.1 When samples are taken at the time the castings are poured, at least one sample shall be taken for each group of castings poured simultaneously from the same source of molten metal.

14.1.1.2 When samples are taken from the semi-finished product, a sample shall be taken to represent each 10 000 lb (4550 kg) or fraction thereof, except that not more than one sample shall be required per piece.

14.1.1.3 Due to the discontinuous nature of the processing of castings into wrought products, it is not practical to identify specific casting analysis with a specific quantity of finished material.

14.1.1.4 In the event that heat identification or traceability is required, the purchaser shall specify the details desired.

#### 14.2 Retests

14.2.1 When requested by the manufacturer or supplier, a retest shall be permitted when results of tests obtained by the purchaser fail to conform to the requirements of the product specification.

14.2.2 The retest shall be as directed in the product specification for the initial test, except the number of test specimens shall be twice that normally required for the specified test.

14.2.3 All test specimens shall conform to the product specification requirement(s) in retest. Failure to conform shall be cause for rejection.

14.2.4 If the chemical analysis fails to conform to the specified limits, analysis shall be made on a new composite sample prepared from additional pieces selected in accordance with 13.1. The results of this retest shall comply with the specified requirements.

#### 15. Test Methods

##### 15.1 Chemical Analysis:

15.1.1 In cases of disagreement, test methods for chemical analysis shall be subject to agreement between the manufacturer or supplier and the purchaser.

15.1.2 The test methods listed below and others not listed may be used, subject to agreement to determine the composition:

Element	Method
Copper	E478
Lead	E478
Iron	E478
Zinc	E478

15.1.3 Test methods to be followed for the determination of elements resulting from contractual or purchase order agreement shall be as agreed upon between the manufacturer or supplier and purchaser.

##### 15.2 Residual Stress Tests:

15.2.1 Unless otherwise agreed upon between the manufacturer or supplier and the purchaser, the manufacturer shall have the option of using either the mercurous nitrate test or the ammonia vapor test.

15.2.2 *Mercurous Nitrate Test*—The material shall be subjected to test in accordance with Test Method B154.

15.2.3 *Ammonia Vapor Test*—The material shall be subjected to test in accordance with Test Method B858. If the pH value is not specified in the product specification, it shall be established in accordance with agreement between the supplier and purchaser.

##### 15.3 Other Tests:

15.3.1 The product furnished shall conform to specified requirements when subjected to test in accordance with the following table:

Test	ASTM Designation (Section 2)
Grain Size	E112
Tension	E8/E8M
Expansion (pin test)	B153

15.4 *Tensile Test*—Tensile test specimens shall be of the full section of the pipe and shall conform to the requirements of the section, Specimens for Pipe and Tube, of Test Methods E8/E8M, unless the limitations of the testing machine preclude the use of such a specimen. Test specimens conforming to Type No. 1 of Fig. 13, Tension Test Specimens for Large-Diameter Tubular Products, of Test Methods E8/E8M is permitted to be used when a full section specimen cannot be tested.

15.4.1 Whenever tensile test results are obtained from both full size and from machined test specimens and they differ, the results obtained from full size test specimens shall be used to determine conformance to the specification requirements.

15.4.2 Tensile test results on material covered by this specification are not seriously affected by variations in speed of testing. A considerable range of testing speed is permissible; however, it is recommended that the rate of stressing to the yield strength not exceed 100 ksi (690 MPa)/min. Above the yield strength it is recommended that the movement per minute of the testing machine head under load not exceed 0.5 in./in. (0.5 mm/mm) of gage length (or distance between grips for full-section specimens).

## 16. Significance of Numerical Limits

16.1 For the purpose of determining compliance with the specified limits for requirements of the properties listed in the following table, an observed value or a calculated value shall be rounded as indicated in accordance with the rounding method of Practice E29.

Property	Rounded Unit for Observed or Calculated Value
Chemical composition	nearest unit in the last right-hand place of figures of the specified limit
Tensile Strength Yield Strength	nearest ksi (nearest 5 MPa)
Elongation	nearest 1 %
Grain size under 0.060 mm	nearest multiple of 0.005 mm
0.060 mm and over	nearest 0.01 mm

## 17. Inspection

17.1 The manufacturer or supplier shall inspect and make tests necessary to verify that the furnished product conforms to specification requirements.

17.2 Source inspection of the product by the purchaser may be agreed upon between the manufacturer or supplier and the purchaser as part of the purchase order. In such case, the nature of the facilities needed to satisfy the inspector that the product is being furnished in accordance with the specification shall be included in the agreement.

17.3 When mutually agreed upon, the manufacturer or supplier and the purchaser shall conduct the final inspection simultaneously.

## 18. Rejection and Rehearing

### 18.1 Rejection:

18.1.1 Product that fails to conform to the specification requirements when tested by the purchaser or purchaser's agent shall be subject to rejection.

18.1.2 Rejection shall be reported to the manufacturer or supplier promptly. In addition, a written notification of rejection shall follow.

18.1.3 In case of dissatisfaction with results of the test upon which rejection is based, the manufacturer or supplier shall have the option to make claim for a rehearing.

### 18.2 Rehearing:

18.2.1 As a result of product rejection, the manufacturer or supplier shall have the option to make claim for a retest to be conducted by the manufacturer or supplier and the purchaser. Samples of the rejected product shall be taken in accordance with the product specification, and subjected to test by both parties using the test method(s) specified by the product specification or, alternately, upon agreement of both parties, an independent laboratory may be selected for the test(s) using the test method(s) specified in the product specification.

## 19. Packaging and Package Marking

### 19.1 Packaging:

19.1.1 The product shall be separated by size and temper, and prepared for shipment by common carrier, in such a manner to afford protection from the normal hazards of transportation.

### 19.2 Package Marking:

19.2.1 Each package shall be legibly marked with the metal or alloy designation, temper, size, gross and net weights, total length or piece count, or both, and name of supplier. Upon agreement between the purchaser and supplier, the purchase order number shall be indicated on each package or on the shipping documents.

19.2.2 When specified in the contract or purchaser order, the specification number shall be shown.

## 20. Certification

20.1 The purchaser shall be furnished certification that samples representing each lot have been tested and inspected as directed in this specification and requirements have been met.

### 20.2 DELETED

## 21. Test Report

21.1 A report of test results shall be furnished.

## 22. Keywords

22.1 copper alloy UNS No. C23000; red brass pipe

## SUPPLEMENTARY REQUIREMENTS

The following supplementary requirements shall apply only when specified by the purchaser in the inquiry, contract, or order, for agencies of the U.S. Government.

### S1. Referenced Documents

S1.1 The following documents of the issue in effect on date of material purchase form a part of this specification to the extent referenced herein:

S1.1.1 *Federal Standard:*

Fed. Std. No. 123 Marking for Shipment (Civil Agencies)

S1.1.2 *Military Standards:*

MIL-STD-129 Marking for Shipment and Storage

MIL-STD-2073/1 Standard Practice for Military Packaging

S1.1.3 *ASTM Standard:*

B900 Practice for Packaging of Copper and Copper-Base Alloy Mill Products for U.S. Government Agencies

S1.1.4 *SAE Standard:*

AMS-STD-185 Identification Marking of Copper and Copper-Base Alloy Mill Products

### S2. Quality Assurance

S2.1 *Responsibility for Inspection:*

S2.1.1 Unless otherwise specified in the contract or purchase order, the manufacturer is responsible for the performance of all inspection and test requirements specified. Except as otherwise specified in the contract or purchase order, the manufacturer shall use his own or any other suitable facilities for the performance of the inspection and test requirements

unless disapproved by the purchaser at the time the order is placed. The purchaser shall have the right to perform any of the inspections or tests set forth when such inspections and tests are deemed necessary to assure that the material conforms to prescribed requirements.

### S3. Identification Marking

S3.1 All material shall be properly marked for identification in accordance with AMS-STD-185 except that the ASTM specification number and the alloy number shall be used.

### S4. Preparation for Delivery

S4.1 *Preservation, Packaging, Packing:*

S4.1.1 *Military Agencies*—The material shall be separated by size, composition, grade, or class and shall be preserved and packaged, Level A or C, and packed, Level A, B, or C, as specified in the contract or purchase order, in accordance with the requirements of Practice B900.

S4.1.2 *Civil Agencies*—The requirements of MIL-STD-2073/1 shall be referenced for definitions of the various levels of packaging protection.

S4.2 *Marking:*

S4.2.1 *Military Agencies*—In addition to any special marking required by the contract or purchase order, marking for shipment shall be in accordance with MIL-STD-129.

S4.2.2 *Civil Agencies*—In addition to any special marking required by the contract or purchase order, marking for shipment shall be in accordance with Fed. Std. No. 123.

## APPENDIX

(Nonmandatory Information)

### X1. METRIC EQUIVALENTS

X1.1 The SI unit for strength properties now shown is in accordance with the International System of Units (SI). The derived SI unit for force is the newton (N), which is defined as that force which when applied to a body having a mass of one kilogram gives it an acceleration of one metre per second squared ( $N = \text{kg} \cdot \text{m} / \text{s}^2$ ). The derived SI unit for pressure or

stress is the newton per square metre ( $\text{N}/\text{m}^2$ ), which has been named the pascal (Pa) by the General Conference on Weights and Measures. Since  $1 \text{ ksi} = 6\,894\,757 \text{ Pa}$  the metric equivalents are expressed as megapascal (MPa), which is the same as  $\text{MN}/\text{m}^2$  and  $\text{N}/\text{mm}^2$ .

## SPECIFICATION FOR STEAM OR VALVE BRONZE CASTINGS

**SB-61**

(25)

(Identical with ASTM Specification B61-15(2021) except certification and test reports have been made mandatory.)

*ASME SB-61 replaces 5.1.7, 5.1.8, 5.1.10, 10, and 10.1 of ASTM B61 with the following:*

5.1.7 Certification (Specification B824).

5.1.8 Foundry test report (Specification B824),

5.1.10 DELETED

### **10. Certification and Test Report**

10.1 The certification and test report requirements of Specification B824 shall apply.



Designation: B61 – 15 (Reapproved 2021)

## Standard Specification for Steam or Valve Bronze Castings<sup>1</sup>

This standard is issued under the fixed designation B61; the number immediately following the designation indicates the year of original adoption or, in the case of revision, the year of last revision. A number in parentheses indicates the year of last reapproval. A superscript epsilon ( $\epsilon$ ) indicates an editorial change since the last revision or reapproval.

*This standard has been approved for use by agencies of the U.S. Department of Defense.*

### 1. Scope\*

1.1 This specification<sup>2</sup> establishes requirements for a high-grade steam-metal or valve-bronze alloy (Copper Alloy UNS No. C92200<sup>3</sup>) used for component castings of valves, flanges, and fittings.

1.2 The castings covered are used in products that may be manufactured in advance and supplied from stock by the manufacturer or other dealer.

1.3 The values stated in inch-pound units are to be regarded as standard. The values given in parentheses are mathematical conversions to SI units that are provided for information only and are not considered standard.

1.4 *This international standard was developed in accordance with internationally recognized principles on standardization established in the Decision on Principles for the Development of International Standards, Guides and Recommendations issued by the World Trade Organization Technical Barriers to Trade (TBT) Committee.*

### 2. Referenced Documents

#### 2.1 ASTM Standards:<sup>4</sup>

B208 Practice for Preparing Tension Test Specimens for Copper Alloy Sand, Permanent Mold, Centrifugal, and Continuous Castings

B824 Specification for General Requirements for Copper Alloy Castings

B846 Terminology for Copper and Copper Alloys

E527 Practice for Numbering Metals and Alloys in the Unified Numbering System (UNS)

2.2 ASME Code:<sup>5</sup>

ASME Boiler and Pressure Vessel Code

2.3 MSS Standard:<sup>6</sup>

SP-25 Standard Marking System for Valves, Fittings, Flanges and Unions

### 3. General Requirements

3.1 The following sections of Specification B824 form a part of this specification. In the event of a conflict between this specification and Specification B824, the requirements of this specification shall take precedence.

3.1.1 Terminology (Section 3),

3.1.2 Other Requirements (Section 7),

3.1.3 Dimensions, Mass, and Permissible Variations (Section 8),

3.1.4 Workmanship, Finish, and Appearance (Section 9),

3.1.5 Sampling (Section 10),

3.1.6 Number of Tests and Retests (Section 11),

3.1.7 Specimen Preparation (Section 12),

3.1.8 Test Methods (Section 13),

3.1.9 Significance of Numerical Limits (Section 14),

3.1.10 Inspection (Section 15),

3.1.11 Rejection and Rehearing (Section 16),

3.1.12 Certification (Section 17),

3.1.13 Test Report (Section 18),

3.1.14 Product Marking (Section 19), and

3.1.15 Packaging and Package Marking (Section 20).

### 4. Terminology

4.1 For definitions of terms relating to copper and copper alloys, refer to Terminology B846.

### 5. Ordering Information

5.1 Include the following information when placing orders for castings under this specification:

<sup>5</sup> Available from American Society of Mechanical Engineers (ASME), ASME International Headquarters, Two Park Ave., New York, NY 10016-5990, <http://www.asme.org>.

<sup>6</sup> Available from Manufacturers Standardization Society (MSS) of the Valve and Fittings Industry, 127 Park St., NE, Vienna, VA 22180-4602, <http://www.msshq.org>.

<sup>1</sup> This practice is under the jurisdiction of ASTM Committee B05 on Copper and Copper Alloys and is the direct responsibility of Subcommittee B05.05 on Castings and Ingots for Remelting.

Current edition approved Oct. 1, 2021. Published October 2021. Originally approved in 1927. Last previous edition approved in 2015 as B61 – 15. DOI: 10.1520/B0061-15R21.

<sup>2</sup> For ASME Boiler and Pressure Vessel Code applications, see related Specification SB-61 of that Code.

<sup>3</sup> The UNS system for copper and copper alloys (see Practice E527) is a simple expansion of the former standard designation system accomplished by the addition of a prefix “C” and a suffix “00.” The suffix can be used to accommodate composition variations of the base alloy.

<sup>4</sup> For referenced ASTM standards, visit the ASTM website, [www.astm.org](http://www.astm.org), or contact ASTM Customer Service at [service@astm.org](mailto:service@astm.org). For *Annual Book of ASTM Standards* volume information, refer to the standard’s Document Summary page on the ASTM website.

- 5.1.1 Quantity of castings required,  
 5.1.2 Copper Alloy UNS No. (Table 1),  
 5.1.3 Specification title, number, and year of issue,  
 5.1.4 Pattern or drawing number and condition (as-cast, machined),  
 5.1.5 Pressure test requirements, if specified in the purchase order (Specification B824),  
 5.1.6 Soundness requirements, if specified in the purchase order (Specification B824),  
 5.1.7 Certification, if specified in the purchase order (Specification B824),  
 5.1.8 Foundry test report, if specified in the purchase order (Specification B824),  
 5.1.9 Witness inspection, if specified in the purchase order (Specification B824),  
 5.1.10 *ASME Boiler and Pressure Vessel Code* application (Section 10), and  
 5.1.11 Product marking, if specified in the purchase order (Specification B824 and Section 11).

5.2 When material is purchased for agencies of the U.S. government, specify the Supplementary Requirements in Specification B824.

## 6. Chemical Composition

6.1 The alloy shall conform to the chemical requirements specified in Table 1.

6.2 These specification limits do not preclude the presence of other elements. Limits may be established for unnamed elements by agreement between manufacturer or supplier and

**TABLE 1 Chemical Requirements, Copper Alloy UNS No. C92200**

Elements	Composition, % max (Except as indicated)
Copper	86.0–90.0
Tin	5.5–6.5
Lead	1.0–2.0
Zinc	3.0–5.0
Nickel including Cobalt	1.0 <sup>A</sup>
Iron	0.25
Antimony	0.25
Sulfur	0.05
Phosphorus <sup>B</sup>	0.05
Aluminum	0.005
Silicon	0.005

<sup>A</sup> In determining copper minimum, copper may be calculated as copper plus nickel.

<sup>B</sup> For continuous castings, phosphorus shall be 1.5 % max.

purchaser. Copper or zinc may be given as remainder and may be taken as the difference between the sum of all elements analyzed and 100 %. When all named elements in Table 1 are analyzed, their sum shall be as follows:

Copper plus named elements, 99.3 % minimum. (1)

## 7. Mechanical Property Requirements

7.1 Mechanical properties shall be determined from separately cast test bars and shall meet the requirements shown in Table 2.

## 8. Casting Repair

8.1 Castings shall not be plugged, welded, burned-in, or impregnated.

## 9. Sampling

9.1 Copper Alloy UNS No. C92200 test bar castings shall be cast to the form and dimensions shown in Figs. 2, 3, or 4 of Practice B208.

## 10. Certification

10.1 When material is specified to meet the requirements of *ASME Boiler and Pressure Vessel Code*, the certification requirements of Specification B824 are mandatory.

## 11. Product Marking

11.1 Valves, flanges, and fittings shall be marked in accordance with the latest revision of the Standard Marking System for Valves, Fittings, Flanges, and Unions (No. SP-25) of the Manufacturers Standardization Society of the Valve and Fittings Industry, and in such position as not to injure the usefulness of the casting.

## 12. Keywords

12.1 Copper Alloy UNS No. C92200 valves; fittings; flanges; Navy M castings; steam bronze castings; valve castings; valve bronze

**TABLE 2 Tensile Properties**

Tensile strength, min, ksi <sup>A</sup> (MPa <sup>B</sup> )	34 (235)
Yield strength, <sup>C</sup> min, ksi <sup>A</sup> (MPa <sup>B</sup> )	16 (110)
Elongation in 2 in. (50.8 mm), min %	24

<sup>A</sup> ksi = 1000 psi.

<sup>B</sup> See Appendix.

<sup>C</sup> Yield strength shall be determined as the stress producing an elongation under load of 0.5 % that is, 0.01 in. (0.25 mm) in a gage length of 2 in. (51 mm).

APPENDIX

(Nonmandatory Information)

XI. METRIC EQUIVALENTS

XI.1 The SI unit for strength properties now shown is in accordance with the International System of Units (SI). The derived SI unit for force is the newton (N), which is defined as that force which when applied to a body having a mass of one kilogram gives it an acceleration of one metre per second squared ( $N = kg \cdot m/s^2$ ). The derived SI unit for pressure or

stress is the newton per square metre ( $N/m^2$ ), which has been named the pascal (Pa) by the General Conference on Weights and Measures. Since  $1 \text{ ksi} = 6\,894\,757 \text{ Pa}$  the metric equivalents are expressed as megapascal (MPa), which is the same as  $MN/m^2$  and  $N/mm^2$ .

SUMMARY OF CHANGES

Committee B05 has identified the location of selected changes to this standard since the last issue (B61-08(2013)) that may impact the use of this standard. (Approved May 1, 2015.)

(1) Table 1 was revised.

(2) Sections 5.1.5 and 6.3 were deleted.

*ASTM International takes no position respecting the validity of any patent rights asserted in connection with any item mentioned in this standard. Users of this standard are expressly advised that determination of the validity of any such patent rights, and the risk of infringement of such rights, are entirely their own responsibility.*

*This standard is subject to revision at any time by the responsible technical committee and must be reviewed every five years and if not revised, either reapproved or withdrawn. Your comments are invited either for revision of this standard or for additional standards and should be addressed to ASTM International Headquarters. Your comments will receive careful consideration at a meeting of the responsible technical committee, which you may attend. If you feel that your comments have not received a fair hearing you should make your views known to the ASTM Committee on Standards, at the address shown below.*

*This standard is copyrighted by ASTM International, 100 Barr Harbor Drive, PO Box C700, West Conshohocken, PA 19428-2959, United States. Individual reprints (single or multiple copies) of this standard may be obtained by contacting ASTM at the above address or at 610-832-9585 (phone), 610-832-9555 (fax), or service@astm.org (e-mail); or through the ASTM website (www.astm.org). Permission rights to photocopy the standard may also be secured from the Copyright Clearance Center, 222 Rosewood Drive, Danvers, MA 01923, Tel: (978) 646-2600; http://www.copyright.com/*

ASME BPVC Section II Part B) 2025  
ASTMENORMDOC.COM : Click to view the full PDF of ASME BPVC.II.B

## SPECIFICATION FOR COMPOSITION BRONZE OR OUNCE METAL CASTINGS



SB-62



(25)

(Identical with ASTM Specification B62-17 except that certification and foundry test reports have been made mandatory.)

*ASME SB-62 replaces 5.1.7, 5.1.8, 5.1.10, 10, and 10.1 of ASTM B62 with the following:*

5.1.7 Certification (Specification B824);

5.1.8 Foundry test report (Specification B824);

5.1.10 DELETED

### **10. Certification and Foundry Test Report**

10.1 The certification and foundry test report requirements of Specification B824 are mandatory.



Designation: B62 – 17

## Standard Specification for Composition Bronze or Ounce Metal Castings<sup>1</sup>

This standard is issued under the fixed designation B62; the number immediately following the designation indicates the year of original adoption or, in the case of revision, the year of last revision. A number in parentheses indicates the year of last reapproval. A superscript epsilon ( $\epsilon$ ) indicates an editorial change since the last revision or reapproval.

*This standard has been approved for use by agencies of the U.S. Department of Defense.*

### 1. Scope\*

1.1 This specification<sup>2</sup> establishes requirements for an alloy having a composition of copper, tin, lead, and zinc, used for component castings of valves, flanges, and fittings. The common trade name of this alloy is 85-5-5-5; the correct identification is Copper Alloy UNS No. C83600.<sup>3</sup>

1.2 The castings covered are used in products that may be manufactured in advance and supplied from stock from the manufacturer or other dealer.

1.3 *Units*—The values stated in inch-pound units are to be regarded as standard. The values given in parentheses are mathematical conversions to SI units, which are provided for information only and are not considered standard.

1.4 *This international standard was developed in accordance with internationally recognized principles on standardization established in the Decision on Principles for the Development of International Standards, Guides and Recommendations issued by the World Trade Organization Technical Barriers to Trade (TBT) Committee.*

### 2. Referenced Documents

#### 2.1 ASTM Standards:<sup>4</sup>

B208 Practice for Preparing Tension Test Specimens for Copper Alloy Sand, Permanent Mold, Centrifugal, and Continuous Castings

B824 Specification for General Requirements for Copper Alloy Castings

B846 Terminology for Copper and Copper Alloys  
E8/E8M Test Methods for Tension Testing of Metallic Materials

E527 Practice for Numbering Metals and Alloys in the Unified Numbering System (UNS)

#### 2.2 MSS Standard:<sup>5</sup>

SP-25 Standard Marking System for Valves, Fittings, Flanges and Unions

### 3. General Requirements

3.1 The following sections of Specification B824 constitute a part of this specification. In the event of a conflict between this specification and Specification B824, the requirements of this specification shall take precedence.

- 3.1.1 Other Requirements (Section 7),
- 3.1.2 Dimensions, Mass, and Permissible Variations (Section 8),
- 3.1.3 Workmanship, Finish, and Appearance (Section 9),
- 3.1.4 Sampling (Section 10),
- 3.1.5 Number of Tests and Retests (Section 11),
- 3.1.6 Specimen Preparation (Section 12),
- 3.1.7 Test Methods (Section 13),
- 3.1.8 Significance of Numerical Limits (Section 14),
- 3.1.9 Inspection (Section 15),
- 3.1.10 Rejection and Rehearing (Section 16),
- 3.1.11 Certification (Section 17),
- 3.1.12 Test Report (Section 18),
- 3.1.13 Product Marking (Section 19), and
- 3.1.14 Packaging and Package Marking (Section 20).

### 4. Terminology

4.1 For definitions of terms relating to copper and copper alloys, refer to Terminology B846.

### 5. Ordering Information

5.1 Include the following information when placing orders for castings under this specification:

- 5.1.1 Quantity of castings required;
- 5.1.2 Copper Alloy UNS No. (Table 1);

<sup>1</sup> This specification is under the jurisdiction of ASTM Committee B05 on Copper and Copper Alloys and is the direct responsibility of Subcommittee B05.05 on Castings and Ingots for Remelting.

Current edition approved April 1, 2017. Published May 2017. Originally approved in 1926. Last previous edition approved in 2015 as B62-15. DOI: 10.1520/B0062-17.

<sup>2</sup> For ASME Boiler and Pressure Vessel Code applications see related Specification SB-61 of that Code.

<sup>3</sup> The UNS system for copper and copper alloys (see Practice E527) is a simple expansion of the former standard designation system accomplished by the addition of a prefix “C” and a suffix “00”. The suffix can be used to accommodate composition variations of the base alloy.

<sup>4</sup> For referenced ASTM standards, visit the ASTM website, [www.astm.org](http://www.astm.org), or contact ASTM Customer Service at [service@astm.org](mailto:service@astm.org). For *Annual Book of ASTM Standards* volume information, refer to the standard’s Document Summary page on the ASTM website.

<sup>5</sup> Available from Manufacturers Standardization Society (MSS) of the Valve and Fittings Industry, 127 Park St., NE, Vienna, VA 22180-4602, <http://www.msshq.org>.

**TABLE 1 Chemical Requirements Copper Alloy UNS No. C83600**

Elements	Composition, % max (Except as Indicated)
Copper	84.0–86.0
Tin	4.0–6.0
Lead	4.0–6.0
Zinc	4.0–6.0
Nickel including Cobalt	1.0 <sup>A</sup>
Iron	0.30
Antimony	0.25
Sulfur	0.08
Phosphorus <sup>B</sup>	0.05
Aluminum	0.005
Silicon	0.005

<sup>A</sup> In determining copper minimum, copper may be calculated as copper plus nickel.

<sup>B</sup> For continuous castings, Phosphorus shall be 1.5 % max.

- 5.1.3 Specification title, number, and year of issue;
- 5.1.4 Pattern or drawing number and condition (as-cast, machined);
- 5.1.5 Pressure test requirements, if specified in the purchase order (Specification B824);
- 5.1.6 Soundness requirements, if specified in the purchase order (Specification B824);
- 5.1.7 Certification, if specified in the purchase order (Specification B824);
- 5.1.8 Foundry test report, if specified in the purchase order (Specification B824);
- 5.1.9 Witness inspection, if specified in the purchase order (Specification B824);
- 5.1.10 ASME Boiler and Pressure Vessel application (Section 10); and
- 5.1.11 Product marking, if specified in the purchase order (Specification B824 and Section 11).

5.2 When material is purchased for agencies of the U.S. Government, specify the Supplementary Requirements in Specification B824.

## 6. Materials and Manufacture

### 6.1 Material(s):

6.1.1 The material of manufacture shall be a casting of Copper Alloy UNS No. C83600 of such purity and soundness as to be suitable for processing into the products prescribed herein.

6.1.2 When specified in the contract or purchase order that heat identification or traceability is required, the purchaser shall specify the details desired.

### 6.2 Manufacture:

6.2.1 The product shall be manufactured by such casting methods as to produce a uniform finished product.

6.2.2 Castings shall not be repaired, plugged, welded, or burned-in.

**TABLE 2 Tensile Properties**

Tensile strength, min, ksi <sup>A</sup> (MPa <sup>B</sup> )	30 (205)
Yield strength, <sup>C</sup> min, ksi <sup>A</sup> (MPa <sup>B</sup> )	14 (95)
Elongation in 2 in. or 50 mm, min, %	20

<sup>A</sup> ksi = 1000 psi.

<sup>B</sup> See Appendix X1.

<sup>C</sup> Yield strength shall be determined as the stress producing an elongation under load of 0.5 %; that is, 0.01 in. (0.25 mm) in a gage length of 2 in. (51 mm).

## 7. Chemical Composition

7.1 The material shall conform to the chemical composition requirements specified in Table 1 for the Copper Alloy UNS No. C83600.

7.2 These composition limits do not preclude the presence of other elements. By agreement between the manufacturer and purchaser, limits may be established and analysis required for unnamed elements.

7.3 Copper or zinc may be given as remainder and may be taken as the difference between the sum of all elements analyzed and 100 %. When all named elements in Table 1 are analyzed, their sum shall be as follows:

$$\text{Copper Plus Named Elements, 99.3 \% Minimum} \quad (1)$$

## 8. Mechanical Property Requirements

8.1 Mechanical properties shall be determined from separately cast test bars and shall meet the requirements shown in Table 2, when tested in accordance with Test Methods E8/E8M.

## 9. Specimen Preparation

9.1 Copper Alloy UNS No. C83600 test bar castings for tensile testing shall be cast to the form and dimensions shown in Fig. 2, Fig. 3, or Fig. 4 of Practice B208.

## 10. Certification

10.1 When material is specified to meet the requirements of *ASME Boiler and Pressure Vessel Code*, the certification requirements of Specification B824 are mandatory.

## 11. Packaging and Package Marking

11.1 Valves, flanges, and fittings shall be marked in accordance with the latest revision of the Standard Marking System for Valves, Fittings, Flanges, and Unions (ANSI/MSS SP-25) of the Manufacturers Standardization Society of the Valve and Fittings Industry, and in such position as not to injure the usefulness of the casting.

## 12. Keywords

12.1 copper-alloy castings; Copper Alloy UNS No. C83600; fittings; flanges; ounce metal castings; red brass castings; valves

## APPENDIX

## (Nonmandatory Information)

## X1. METRIC EQUIVALENTS

X1.1 The SI unit for strength properties now shown is in accordance with the International System of Units (SI). The derived SI unit for force is the newton (N), which is defined as that force which when applied to a body having a mass of one kilogram gives it an acceleration of one metre per second squared ( $N = \text{kg}\cdot\text{m}/\text{s}^2$ ). The derived SI unit for pressure or

stress is the newton per square metre ( $\text{N}/\text{m}^2$ ), which has been named the pascal (Pa) by the General Conference on Weights and Measures. Since  $1 \text{ ksi} = 6\,894\,757 \text{ Pa}$  the metric equivalents are expressed as megapascal (MPa), which is the same as  $\text{MN}/\text{m}^2$  and  $\text{N}/\text{mm}^2$ .

## SUMMARY OF CHANGES

Committee B05 has identified the location of selected changes to this standard since the last issue (B62-15) that may impact the use of this standard. (Approved April 1, 2017.)

- |  |  |
|--|--|
| <p>(1) A comprehensive review was made, incorporating current proper form and style practices.</p> <p>(2) Added Section 6 and renumbered sections that follow.</p> | <p>(3) Relocated requirements of Section 8 into new Section 6.</p> <p>(4) Renamed and revised Section 9 to align with referenced requirements in Specification B824.</p> |
|--|--|

*ASTM International takes no position respecting the validity of any patent rights asserted in connection with any item mentioned in this standard. Users of this standard are expressly advised that determination of the validity of any such patent rights, and the risk of infringement of such rights, are entirely their own responsibility.*

*This standard is subject to revision at any time by the responsible technical committee and must be reviewed every five years and if not revised, either reapproved or withdrawn. Your comments are invited either for revision of this standard or for additional standards and should be addressed to ASTM International Headquarters. Your comments will receive careful consideration at a meeting of the responsible technical committee, which you may attend. If you feel that your comments have not received a fair hearing you should make your views known to the ASTM Committee on Standards, at the address shown below.*

*This standard is copyrighted by ASTM International, 100 Barr Harbor Drive, PO Box C700, West Conshohocken, PA 19428-2959, United States. Individual reprints (single or multiple copies) of this standard may be obtained by contacting ASTM at the above address or at 610-832-9585 (phone), 610-832-9555 (fax), or service@astm.org (e-mail); or through the ASTM website (www.astm.org). Permission rights to photocopy the standard may also be secured from the Copyright Clearance Center, 222 Rosewood Drive, Danvers, MA 01923, Tel: (978) 646-2600; http://www.copyright.com/*

## SPECIFICATION FOR SEAMLESS COPPER TUBE



**SB-75/SB-75M**

(Identical with ASTM Specification B75/B75M-19 except for deletion of 11.1.3, footnote G in Table 2, footnote F in Table 3; certification and test report have been made mandatory.)

ASMENORMDOC.COM : Click to view the full PDF of ASME BPVC.II.B (ASME BPVC Section II part B) 2025

# Specification for Seamless Copper Tube

## 1. Scope

1.1 This specification establishes the requirements for seamless round, rectangular, and square copper tube suitable for general engineering applications.

1.1.1 Tubes made from any of the following Copper UNS No. designations shall be supplied unless otherwise specified in the contract or purchase order:

Copper UNS No.	Type of Copper
C10100	Oxygen-free electronic
C10200	Oxygen-free without residual deoxidants
C10300	Oxygen-free, extra low phosphorus
C10800	Oxygen-free, low phosphorus
C12000	Phosphorus deoxidized, low residual phosphorus
C12200	Phosphorus deoxidized, high residual phosphorus

1.2 *Units*—The values stated in either inch-pound units or SI units are to be regarded separately as standard. Within the text, SI units are shown in brackets. The values stated in each system are not necessarily exact equivalents; therefore, to ensure conformance with the standard, each system shall be used independently of the other, and values from the two systems shall not be combined.

1.3 The following safety hazard caveat pertains only to the test methods described in this specification: *This standard does not purport to address all of the safety concerns, if any, associated with its use. It is the responsibility of the user of this standard to establish appropriate safety, health, and environmental practices and determine the applicability of regulatory limitations prior to use.*

1.4 *This international standard was developed in accordance with internationally recognized principles on standardization established in the Decision on Principles for the Development of International Standards, Guides and Recommendations issued by the World Trade Organization Technical Barriers to Trade (TBT) Committee.*

## 2. Referenced Documents

### 2.1 ASTM Standards:

- B153 Test Method for Expansion (Pin Test) of Copper and Copper-Alloy Pipe and Tubing
- B170 Specification for Oxygen-Free Electrolytic Copper—Refinery Shapes
- B193 Test Method for Resistivity of Electrical Conductor Materials
- B251/B251M Specification for General Requirements for Wrought Seamless Copper and Copper-Alloy Tube
- B577 Test Methods for Detection of Cuprous Oxide (Hydrogen Embrittlement Susceptibility) in Copper
- B601 Classification for Temper Designations for Copper and Copper Alloys—Wrought and Cast
- B846 Terminology for Copper and Copper Alloys
- E8/E8M Test Methods for Tension Testing of Metallic Materials
- E18 Test Methods for Rockwell Hardness of Metallic Materials
- E53 Test Method for Determination of Copper in Unalloyed Copper by Gravimetry
- E62 Test Methods for Chemical Analysis of Copper and Copper Alloys (Photometric Methods) (Withdrawn 2010)
- E112 Test Methods for Determining Average Grain Size
- E243 Practice for Electromagnetic (Eddy Current) Examination of Copper and Copper-Alloy Tubes
- E255 Practice for Sampling Copper and Copper Alloys for the Determination of Chemical Composition

### 2.2 ASME Standard:

- ASME Boiler and Pressure Vessel Code

## 3. General Requirements

3.1 The following sections of Specification B251/B251M are a part of this specification.

- 3.1.1 Terminology, General;
- 3.1.2 Material and Manufacture;
- 3.1.3 Workmanship, Finish, and Appearance;
- 3.1.4 Significance of Numerical Limits;
- 3.1.5 Inspection;
- 3.1.6 Rejection and Reheating;
- 3.1.7 Certification;
- 3.1.8 Mill Test Reports;
- 3.1.9 Packaging and Package Marking; and
- 3.1.10 Supplementary Requirements.

3.2 In addition, when a section with an identical title to those referenced in section 3.1 appears in this specification, and is in conflict with the section appearing in Specification B251/B251M, the section in this specification shall prevail.

#### 4. Terminology

4.1 *Definitions*—For definitions of terms related to copper and copper alloys, refer to Terminology B846.

#### 5. Ordering Information

5.1 Include the following specific choices when placing orders for product under this specification, as applicable.

- 5.1.1 ASME designation
- 5.1.2 Copper UNS No. (for example, C10100);
- 5.1.3 Temper (Section 8);
- 5.1.4 Dimensions; diameter or distance between parallel surfaces, and wall thickness (Section 17);
- 5.1.5 How furnished; coils or straight lengths;
- 5.1.6 Number of pieces or footage; each size and type;
- 5.1.7 Total weight.

5.2 The following options are available but may not be included unless specified at the time of placing the order, when required:

- 5.2.1 Electrical mass resistivity test,
- 5.2.2 Hydrogen embrittlement test,
- 5.2.3 Hydrostatic test for pressures less than or equal to 1000 psi (21.2.8),
- 5.2.4 Hydrostatic test for pressures over 1000 psi (21.2.8.1),
- 5.2.5 Pneumatic test,
- 5.2.6 DELETED
- 5.2.7 DELETED
- 5.2.8 Expansion test,
- 5.2.9 DELETED
- 5.2.10 When product is purchased for agencies of the U.S. Government.

#### 6. Material and Manufacture

6.1 *Material*—The material of manufacture shall be billets, bars, or tube of Copper UNS No. C10100, C10200, C10300, C10800, C12000, or C12200, and shall be of such soundness as to be suitable for processing into the tubular products described.

##### 6.2 *Manufacture:*

6.2.1 The tube shall be manufactured by such hot- and cold-working processes as to produce a uniform wrought structure in the finished product. It shall be cold drawn to the finished size and wall thickness.

6.2.2 When cold-drawn temper is required, the final drawing operation shall be such as to meet the specified temper. When annealed temper is required, the tube shall be annealed subsequent to the final cold draw.

#### 7. Chemical Composition

7.1 The material shall conform to the requirements in Table 1 for the specified Copper UNS No. designation.

7.1.1 These composition limits do not preclude the presence of other elements. By agreement between the manufacturer or supplier and the purchaser, limits may be established and analysis required for unnamed elements.

#### 8. Temper

8.1 The requirements and size availability of tube in the cold-drawn tempers H55, H58, and H80, as defined in Classification B601, are specified in Table 2 or Table 3.

8.1.1 Rectangular, including square, tube shall normally be supplied only in H58 temper. When requested by the manufacturer or supplier, and upon agreement with the purchaser, tube may be supplied in H55 temper.

8.1.1.1 For any combination of diameter and wall thickness not listed under H80 temper, the requirements specified for H58 temper shall apply.

8.2 The requirements and size availability of tube in the annealed tempers O50, O60, and O62 as defined in Classification B601, are specified in Table 2 or Table 3.

NOTE 1—The purchaser shall confer with the manufacturer or supplier for the availability of product in a specific temper.

NOTE 2—Refer to Appendix X1 for recommended applications based on temper.

#### 9. Grain Size Requirements

9.1 Tube in the annealed temper shall conform to the grain size specified in Table 2 or Table 3.

TABLE 1 Chemical Requirements

Element	Composition, %					
	Copper UNS No.					
	C10100 <sup>A</sup>	C10200 <sup>B</sup>	C10300	C10800	C12000	C12200
Copper, min	99.99	99.95	...	...	99.90	99.9
Copper + phosphorus, min	...	...	99.95	99.95	...	...
Phosphorus	...	...	0.001–0.005	0.005–0.012	0.004–0.012	0.015–0.040

<sup>A</sup> Refer to Table 1, Chemical Requirements, Grade 1, of Specification B170 for impurity limits for Copper UNS No. C10100.

<sup>B</sup> Refer to Table 1, Chemical Requirements, Grade 2, of Specification B170 for impurity limits for Copper UNS No. C10200.

**TABLE 2 Mechanical Property Requirements of Drawn-Temper and Annealed-Temper Tube (inch-pound values)**

Temper Designation		Outside Diameter, or Major Distance Between Outside Parallel Surfaces, in.	Wall Thickness, in.	Rockwell Hardness <sup>A</sup>		Average Grain Size, mm	Tensile Strength, ksi <sup>B</sup>	Yield Strength, <sup>C</sup> min, ksi <sup>D</sup>
Code	Name			Scale	Hardness			
H55	light-drawn <sup>D</sup>	all	all	30T	30 to 60		36–47	30
H58	drawn (general purpose)	all	all	30T	30 min		36 min	30
H80	hard-drawn <sup>D</sup>	up to 4	0.020 to 0.250, incl	30T	55 min		45 min	40
O62	heavy anneal	all	0.015 to 0.035	15T <sup>E</sup>	60 max	0.050 max	30 min	6.5 <sup>F</sup>
			0.035 and over	F <sup>E</sup>	55 max			
O60	soft anneal	all	0.015 to 0.035	15T	60 max	0.040 min	30 min	9
			0.035 and over	F	50 max			
O50	light anneal	all	0.015 to 0.035	15T	65 max	0.040 max	30 min	9
			0.035 and over	F	55 max			

<sup>A</sup> Rockwell hardness tests shall be made on the inside surface of the tube. When suitable equipment is not available for determining the specified Rockwell hardness, other Rockwell scales and values shall be specified subject to agreement between the purchaser and supplier.

<sup>B</sup> ksi = 1000 psi.

<sup>C</sup> Yield strength to be determined at 0.5 % extension under load.

<sup>D</sup> Light-drawn and hard-drawn tempers are normally available in round tubes only.

<sup>E</sup> Rockwell hardness values shall apply only to tubes having a wall thickness of 0.015 in. or over, to round tubes having an inside diameter of 5/16 in. or over, and to rectangular, including square, tubes having an inside major distance between parallel surfaces of 3/16 in. or over. For all other tube, no Rockwell values shall apply. Rockwell hardness tests shall be made on the inside surface of the tube. When suitable equipment is not available for determining the specified Rockwell hardness, other Rockwell scales and values shall be specified subject to agreement between the purchaser and supplier.

<sup>F</sup> Light-straightening operation is acceptable.

<sup>G</sup> DELETED

**TABLE 3 Mechanical Property Requirements of Drawn-Temper and Annealed-Temper Tube (SI Values)**

Temper Designation		Outside Diameter, or Major Distance Between Outside Parallel Surfaces, mm	Wall Thickness, mm	Rockwell Hardness <sup>A</sup>		Average Grain Size, mm	Tensile Strength, <sup>B</sup> MPa	Yield Strength, <sup>B</sup> min, MPa
Standard	Former			Scale	Hardness			
H55	light-drawn <sup>C</sup>	all	all	30T	30 to 60		250–325	205
H58	drawn (general purpose)	all	all	30T	30 min		250 min	205
H80	hard-drawn <sup>C</sup>	up to 102	0.508 to 6.35, incl	30T	55 min		310 min	275
O62	heavy anneal	all	0.381 to 0.889	15T <sup>D</sup>	60 max	0.050 max	205 min	45 <sup>E, F</sup>
			0.889 and over	F <sup>D</sup>	55 max			
O60	soft anneal	all	0.381 to 0.889	15T	60 max	0.040 min	205 min	62
			0.889 and over	F	50 max			
O50	light anneal	all	0.381 to 0.889	15T	65 max	0.040 max	205 min	62
			0.889 and over	F	55 max			

<sup>A</sup> Rockwell hardness tests shall be made on the inside surface of the tube. When suitable equipment is not available for determining the specified Rockwell hardness, other Rockwell scales and values shall be specified subject to agreement between the purchaser and supplier.

<sup>B</sup> Yield strength to be determined at 0.5 % extension under load.

<sup>C</sup> Light-drawn and hard-drawn tempers are normally available in round tubes only.

<sup>D</sup> Rockwell hardness values shall apply only to tubes having a wall thickness of 0.040 mm or over, to round tubes having an inside diameter of 8.0 or over, and to rectangular, including square, tubes having an inside major distance between parallel surfaces of 5.0 mm or over. For all other tube, no Rockwell values shall apply. Rockwell hardness tests shall be made on the inside surface of the tube. When suitable equipment is not available for determining the specified Rockwell hardness, other Rockwell scales and values shall be specified subject to agreement between the purchaser and supplier.

<sup>E</sup> Light-straightening operation shall be permitted.

<sup>F</sup> DELETED

9.2 Acceptance or rejection based upon grain size shall depend only on the average grain size of a test specimen taken from each of two sample portions, and each specimen shall be within the limits prescribed in Table 2 or Table 3 when determined in accordance with Test Methods E112.

**10. Physical Property Requirements**

10.1 *Electrical Resistivity*—When specified in the contract or purchase order, tube ordered for electrical conductor application produced from Copper UNS No. C10100, C10200,

C10300, or C12000 shall have an electrical mass resistivity,  $\Omega \cdot \text{g}/\text{m}^2$ , not to exceed the following limit for the specified copper and temper when tested in accordance with Test Method B193:

Temper	Copper UNS No.			
	C10100	C10200	C10300	C12000
O60, O50	0.151 76	0.153 28	0.156 14	0.170 31
H55, H58, H80	0.156 14	0.157 37	0.159 40	0.174 18

NOTE 3—Refer to Appendix X2 for the International Annealed Copper Standard (IACS) electrical conductivity equivalents.

## 11. Mechanical Property Requirements

### 11.1 Tensile and Yield Strength Requirements:

11.1.1 The tube furnished under this specification shall conform to the requirements of Table 2 or Table 3 for the specified temper and wall thickness when tested in accordance with Test Methods E8/E8M.

11.1.2 For any combination of diameter and wall thickness not listed under H80, the requirements for H58 shall apply.

#### 11.1.3 DELETED

### 11.2 Rockwell Hardness Requirements:

11.2.1 The tube shall conform to the Rockwell hardness requirements of Table 2 or Table 3 for the specified temper and wall thickness when tested in accordance with Test Methods E18.

11.2.1.1 The Rockwell Hardness values for tube in the H55, H58, and H80 temper shall apply only to the following:

(a) Tubes having a wall thickness of 0.020 in. [0.508 mm] and over,

(b) Round tubes having an inside diameter of  $\frac{5}{16}$  in. [8.0 mm] and over,

(c) Rectangular and square tubes having major distances between parallel surfaces of  $\frac{3}{16}$  in. [5 mm] and over.

11.2.1.2 The Rockwell Hardness values for tube in the O60 and O50 temper shall apply only to the following:

(a) Tubes having a wall thickness of 0.015 in. [0.38 mm] and over;

(b) Round tubes having an inside diameter of  $\frac{5}{16}$  in. [8 mm] and over;

(c) Rectangular and square tubes having inside major distances between parallel surfaces of  $\frac{3}{16}$  in. [5 mm] and over.

11.3 *Straightening*—It shall not be prohibited to use light straightening for tube in the O60 and O50 temper.

11.4 When a discrepancy between tensile and Rockwell hardness exists, tensile always takes precedence for acceptance or rejection criteria.

## 12. Performance Requirements

### 12.1 Expansion Test for Round Tube:

12.1.1 When specified in the contract or purchase order, annealed tubes shall be capable of withstanding an expansion of the outside diameter of 40 % for tube  $\frac{3}{4}$  in. [19.0 mm] and under and 30 % for tube over  $\frac{3}{4}$  in. [19.0 mm] when tested in accordance with Test Method B153.

12.1.2 The expanded tube shall show no cracking or rupture visible to the unaided eye.

## 13. Microscopical Examination

13.1 Tubes furnished in Copper UNS No. C10100, C10200, C10300, and C12000 shall be essentially free of cuprous oxide as determined by Procedure A of Test Methods B577.

## 14. Hydrogen Embrittlement

14.1 When specified in the contract or purchase order, tubes produced in all designated copper material shall be capable of conforming to the requirements of Procedure B of Test Methods B577.

## 15. Nondestructive Test

15.1 The tubes shall be tested in drawn tempers or as drawn before the final-annealed temper unless otherwise agreed upon between the manufacturer and the purchaser.

### 15.2 Electromagnetic (Eddy-Current) Test:

15.2.1 Each tube up to and including  $3\frac{1}{8}$  in. [79 mm] in outside diameter shall be subjected to test.

15.2.2 When tested in accordance with Practice E243, tubes which do not actuate the signaling device of the testing unit shall be considered as conforming to the requirements of the test.

15.3 *Hydrostatic Pressure Test*—When specified in the contract or purchase order, each tube shall be capable of withstanding an internal hydrostatic pressure sufficient to produce a fiber stress of 6000 psi [41 MPa] without leakage. The tube need not be subjected to a pressure gauge reading over 1000 psi [6.9 MPa] unless specifically stipulated in the contract or purchase order.

15.4 *Pneumatic Pressure Test*—When specified in the contract or purchase order, each tube shall be capable of withstanding an internal air pressure of 60 psi [400 kPa], minimum, for 5 s without leakage.

## 16. Purchases for U.S. Government Agencies

16.1 When the contract or purchase order stipulates that the purchase is for an agency of the U.S. Government, the tubes furnished shall conform to the conditions specified in the Supplementary Requirements of Specification B251/B251M.

## 17. Dimensions, Mass, and Permissible Variations

17.1 The dimensions and tolerances for product described by this specification shall be as specified in the following tables and related sections of the current edition of Specification B251/B251M:

17.1.1 *Wall Thickness Tolerances*—Refer to Tables 1 and 2.

17.1.2 *Tolerances for Diameter or Distance Between Parallel Surfaces*—Refer to Tables 3 and 4.

17.1.3 *Length Tolerances*—Refer to Tables 5 and 6.

17.1.4 *Straightness Tolerance*—Refer to Table 7.

17.1.5 *Corner Radius for Rectangular, including Square, Tube*—Refer to Table 8.

17.1.6 *Roundness, Squareness of Cut and Twist Tolerances for Rectangular and Square Tubes*—Refer to titled sections.

17.2 *Length Tolerances for Tube in Coils*—Refer to Table 4, Table 5, Table 6, Table 7, Table 8 and Table 9 of this specification.

**18. Sampling**

18.1 The lot size, portion size, and selection of sample portions shall be as follows:

18.1.1 *Lot Size*—An inspection lot shall be 10 000 lb [5000 kg] or fraction thereof,

18.1.2 *Portion Size*—Sample pieces shall be selected to be represented of the lot as follows:

Number of Pieces in Lot	Number of Portions to Be Taken <sup>A</sup>
1 to 50	1
51 to 200	2
201 to 1500	3

<sup>A</sup> Each test portion shall be taken from a separate tube.

**18.2 Chemical Composition:**

18.2.1 The composite sample shall be taken in approximate equal weights from each portion piece selected in 18.1.2 and in accordance with Practice E255. The minimum weight of the composite shall be 150 g.

18.2.2 The manufacturer shall have the option of sampling at the time the castings are poured or taken from the semifinished product. The number of samples taken during the course of manufacture shall be as follows:

18.2.2.1 When sampled at the time castings are poured, at least two samples shall be taken, one after the start and one near the end of the pour, for each group of castings poured simultaneously from the same source of molten metal.

18.2.2.2 When samples are taken from the semifinished product, a sample shall be taken to represent each 10 000 lb [5000 kg] or fraction thereof, except that not more than one sample per piece shall be required.

18.2.2.3 When composition is determined during the course of manufacture, sampling and analyses of the finished product is not required.

18.3 *Other Tests*—Specimens for all other tests shall be taken from two of the sample portions taken in 18.1.2. In the event only one sample portion is taken, all specimens shall be taken from the portion selected.

**19. Number of Tests and Retests**

19.1 *Tests:*

19.1.1 *Chemical Analysis*—Chemical composition shall be determined in accordance with the element mean of the results from at least two replicate analyses of the sample(s).

19.1.2 *Grain Size, Electrical Resistivity, Tensile and Yield Strength, and Rockwell Hardness*—Results shall be reported as

**TABLE 4 Coil Length Tolerances (Specific Lengths) Inch-Pound Values**

Outside Diameter or Major Distance Between Parallel Surfaces, in.	Tolerances, in., All Plus, for Nominal Lengths, ft	
	Up to 50, incl	Over 50 to 100, incl
Up to 2, incl	12	24

**TABLE 5 Coil Length Tolerances (Specific Lengths) SI Values**

Outside Diameter or Major Distance Between Parallel Surfaces, mm	Tolerances, mm, All Plus, for Nominal Lengths, m	
	Up to 15, incl	Over 15 to 30, incl
Up to 50.8, incl	300	610

the average obtained from two test specimens, each taken from a separate test piece, where possible.

19.1.3 *Other Tests*—At least two specimens shall be prepared for each of the other tests and each shall conform to test requirements.

19.2 *Retests:*

19.2.1 When requested by the manufacturer or supplier, a retest shall be permitted when results of tests obtained by the purchaser fail to conform to the requirements of the product specification.

19.2.2 The retest shall be as directed in the product specification for the initial test, except for the number of test specimens shall be twice that normally required for the specified test.

19.2.3 All test specimens shall conform to the product specification requirement(s) in retest. Failure to conform shall be cause for rejection.

**20. Specimen Preparation**

20.1 *Chemical Analysis*—Preparation of the analytical specimens shall be the responsibility of the reporting laboratory.

20.2 *Tensile and Yield Strength Test*—The test specimens shall be of the full section of the tube and shall conform with the requirements of the Test Specimen section of Test Methods E8/E8M, unless the limitation of the testing machine precludes the use of such specimens in which case test specimens conforming to Type No. 1 of Fig. 13 in Test Methods E8/E8M shall be used.

20.3 *Rockwell Hardness:*

20.3.1 The test specimen shall be of a size and shape to permit testing by the available test equipment.

20.3.2 The surface of the test specimen shall be sufficiently flat and smooth so as to permit the accurate determination of hardness.

20.3.3 The test specimen shall be free from scale and foreign matter and care shall be taken to avoid any change in condition (for example, heating or cold working).

20.4 *Grain Size*—Test specimens shall be prepared in accordance with the appropriate procedure in Test Methods E112

20.5 *Electrical Resistivity:*

20.5.1 The test specimen shall be full size and shall be the full cross section of the material it represents when possible.

20.5.2 When the test specimen is taken from material in bulk, care shall be taken that the properties are not appreciably altered in the preparation.

NOTE 4—Plastic deformation tends to work harden a material and raise its resistivity, while heating tends to anneal the material with a subsequent reduction in resistivity.

**TABLE 6 Coil Length Tolerances (Mill Lengths) Inch-Pound Values  
(Applicable Only to Full-Length Pieces)**

Tube Outside Diameter or Major Distance Between Parallel Surfaces, in. [mm]	Tolerances, %, for Nominal Lengths, ft [mm]	
	Up to 100 [30 480], incl	Over 100 to 2000 [30 480 to 609 600], incl
Up to 1 [25], incl	5 <sup>A</sup> or 2 ft, whichever is greater	10 <sup>A</sup>
Over 1 to 2 [25 to 51], incl	5 <sup>A</sup> or 2 ft, whichever is greater	no tolerances established

<sup>A</sup> Expressed to the nearest 1 ft.

**TABLE 7 Coil Length Tolerances (Mill Lengths) SI Values  
(Applicable Only to Full-Length Pieces)**

Tube Outside Diameter or Major Distance Between Parallel Surfaces, mm	Tolerances, %, for Nominal Lengths in mm	
	Up to 30 000, incl	Over 30 000 to 600 000, incl
Up to 25, incl	5 <sup>A</sup> or 600, whichever is greater	10 <sup>A</sup>
25 to 50, incl	5 <sup>A</sup> or 600, whichever is greater	no tolerances established

<sup>A</sup> Expressed to the nearest 300 mm.

**TABLE 8 Coil Schedule of Mill Lengths with Ends, Inch-Pound Values**

Tube Outside Diameter or Major Distance Between Parallel Surfaces, in.	Nominal Length, ft	Shortest Permissible Length, % of Nominal Length	Maximum Permissible Weights of Ends, % of Lot Weight
Up to 1, incl	up to 100, incl	70 <sup>A</sup>	10
Over 1 to 2, incl	up to 100, incl	60 <sup>A</sup>	20
Up to 1, incl	over 100 to 2000, incl	50	50 <sup>B</sup>

<sup>A</sup> Expressed to the nearest 1 ft.

<sup>B</sup> Short pieces of lengths between 50 ft and one-quarter of full length shall not exceed 10 % of lot weight. Short pieces of lengths between one-quarter of a full length and full length shall not exceed 40 % of lot weight.

**TABLE 9 Coil Schedule of Mill Lengths with Ends, SI Values**

Tube Outside Diameter or Major Distance Between Parallel Surfaces, mm	Nominal Length, mm	Shortest Permissible Length, % of Nominal Length	Maximum Permissible Mass of Ends, % of Lot Weight
Up to 25, incl	up to 30 000, incl	70 <sup>A</sup>	10
Over 25 to 50, incl	up to 30 000, incl	60 <sup>A</sup>	20
Up to 25, incl	over 30 000 to 600 000, incl	50	50 <sup>B</sup>

<sup>A</sup> Expressed to the nearest 300.

<sup>B</sup> Short pieces are permitted to be included as follows: up to 10 % of lot weight between 15 200 and one quarter of full length and up to 40 % between one quarter and full length.

20.6 *Expansion (Pin) Test*—Test specimens shall conform to the requirements of the Specimen Preparation section of Test Method B153.

20.7 *Microscopical Examination*—The test specimen shall be prepared in accordance with Procedure A of Test Methods B577 and the specimen surface shall approximate a radial longitudinal section of round tube or a longitudinal section of rectangular and square tube perpendicular to, and bisecting, the major dimensional surface.

20.8 *Hydrogen Embrittlement*—The test specimen shall conform to the appropriate requirements of Procedure B of Test Methods B577.

## 21. Test Methods

21.1 *Chemical Analyses*—In case of disagreement, test methods for chemical analysis shall be subject to agreement between the manufacturer or supplier and the purchaser. The following table is a list of published methods, some of which may no longer be viable, which, along with others not listed, may be used subject to agreement.

Element	Test Method
Copper	E53
Phosphorus	E62

21.1.1 The test methods for the determination of composition for Coppers C10100 and C10200 shall be as described in Annex of Specification B170.

21.1.2 Test method(s) for the determination of element(s) required by contractual or purchase order agreement shall be as agreed upon between the manufacturer and the purchaser.

21.2 The tubes furnished shall conform to the physical and mechanical properties and other requirements of this specification when tested or examined in accordance with the following appropriate test method or practice:

Test	Test Method
Tensile strength	E8/E8M
Yield strength	E8/E8M
Rockwell Hardness	E18
Grain size	E112
Electrical resistivity	B193
Expansion (pin test)	B153

Electromagnetic examination (eddy current)	E243
Microscopical examination, Procedure A	B577
Hydrogen embrittlement, Procedure B	B577
Hydrostatic pressure	B75/B75M, 21.2.8
Pneumatic pressure	B75/B75M, 21.2.9

21.2.1 Whenever test results are obtained from both full-size and machined specimens and they differ, the test results from the full-size specimens shall prevail.

21.2.2 Rockwell hardness shall be determined on the inside surface of the tube and a minimum of three readings shall be taken on each specimen, each at a different location.

21.2.2.1 When suitable equipment is not available for determining the specified Rockwell hardness, other Rockwell scales and values shall be specified by agreement between the manufacturer and the purchaser.

21.2.3 Grain size shall be determined, in case of dispute, by the intercept method.

21.2.4 *Electrical Resistivity*—The limit of measurement uncertainty shall be ±0.30 % as a process control method and ±0.15 % as an umpire method.

21.2.5 *Microscopical Examination*—Cuprous oxide content shall be determined in accordance with Procedure A, or, in case of dispute, Procedure C, Closed Bend Test, of Test Methods B577 shall be followed.

21.2.6 *Hydrogen Embrittlement*—Procedure B shall be followed, or, in case of dispute, Procedure C, Closed Bend Test, of Test Methods B577 shall be followed.

21.2.7 *Electromagnetic (Eddy-Current) Test*—Each tube up to and including 3 1/8 in. [79 mm] in outside diameter shall be subjected to an eddy-current test. Testing shall follow the procedures in Practice E243.

21.2.7.1 Either notch depth or drilled hole standards shall be used.

(a) Notch depth standards, rounded to the nearest 0.001 in. [0.025 mm] shall be 22 % maximum of the wall thickness. The notch depth tolerance shall be ±0.0005 in. [±0.013 mm].

(b) Drilled holes shall be drilled radially through the wall using a suitable drill jig that has a bushing to guide the drill, care being taken to avoid distortion of the tube while drilling. The diameter of the drilled hole shall be in accordance with the following and shall not vary by more than +0.001, -0.000 in. [+0.025 mm, -0.000 mm] of the hole diameter specified.

Tube Outside Diameter, in. [mm]	Diameter of Drilled Holes, in. [mm]	Drill Number
1/4 to 3/4, incl [6.0 to 19, incl]	0.025 [0.635]	72
Over 3/4 to 1, incl [Over 19.0 to 25, incl]	0.031 [0.787]	68
Over 1 to 1 1/4, incl [Over 25 to 32, incl]	0.036 [0.915]	64
Over 1 1/4 to 1 1/2, incl [Over 32 to 38, incl]	0.042 [1.07]	58
Over 1 1/2 to 1 3/4, incl [Over 38 to 45, incl]	0.046 [1.17]	56
Over 1 3/4 to 2, incl [Over 45 to 50, incl]	0.052 [1.32]	55

21.2.7.2 Alternatively, at the option of the manufacturer, using speed-insensitive eddy-current units that are equipped to select a fraction of the maximum imbalance signal, the following percent maximum imbalance signals shall be used:

Standard Tube Size, in. [mm]	Maximum Percent Imbalance Signal Magnitude
Up to 3/8, incl [Up to 9, incl]	0.2
Over 3/8 to 2, incl [Over 13 to 50, incl]	0.3
Over 2 to 3, incl [Over 50 to 76, incl]	0.4

21.2.7.3 Tubes that do not activate the signaling device of the eddy-current tester shall be considered as conforming to the requirements of this test. Tubes with discontinuities indicated by the testing unit are not prohibited, at the option of the manufacturer, from being reexamined or retested to determine whether the discontinuity is cause for rejection. Signals that are found to have been caused by minor mechanical damage, soil or moisture, shall not be cause for rejection of the tubes provided the tube dimensions are still within prescribed limits and the tube is suitable for its intended application.

21.2.8 *Hydrostatic Test*—The internal hydrostatic pressure necessary to produce the required fiber stress shall be determined by the following equation for thin hollow cylinders under tension.

$$P = 2St/(D - 0.8t) \tag{1}$$

where:

- P* = hydrostatic pressure, psi [or MPa];
- t* = thickness of tube wall, in. [or mm];
- D* = outside diameter of tube, in. [or mm]; and
- S* = allowable fiber stress of the material, psi [MPa].

21.2.8.1 The tube need not be tested at a pressure gauge reading over 1000 psi [6.9 MPa] unless so specified.

21.2.9 *Pneumatic Test*—The test method shall permit easy visual detection of leakage, such as having the material under water or by the pressure differential method.

**22. Rejection and Rehearing**

*22.1 Rejection:*

22.1.1 Product that fails to conform to the specification requirements when tested by the purchaser or purchaser’s agent shall be subject to rejection.

22.1.2 Rejection shall be reported to the manufacturer or supplier promptly. In addition, a written notification of rejection shall follow.

22.1.3 In case of dissatisfaction with results of the test upon which rejection is based, the manufacturer or supplier shall have the option to make claim for a rehearing.

*22.2 Rehearing:*

22.2.1 As a result of product rejection, the manufacturer or supplier shall have the option to make claim for a retest to be conducted by the manufacturer or supplier and the purchaser. Samples of the rejected product shall be taken in accordance with the product specification and subjected to test by both parties using the test method(s) specified in the product specification, or alternately, upon agreement of both parties, an independent laboratory may be selected for the test(s) using the test method(s) specified in the product specification.

**23. Certification**

23.1 The purchaser shall be furnished certification that samples representing each lot have been tested and inspected as directed in this specification and requirements have been met.

23.2 DELETED

**24. Test Report**

24.1 A report of test results shall be furnished.

**25. Keywords**

25.1 seamless copper tube; seamless tube; tube; C10100; C10200; C10300; C10800; C12000; C12200

**APPENDIXES**

(Nonmandatory Information)

**X1. RECOMMENDED APPLICATIONS**

X1.1 Tube in the H55 temper is recommended when a tube of some stiffness is required yet capable of being bent when necessary.

X1.2 Tube in the H58 temper is recommended for general applications in which there is no specific need for high strength or bending qualities.

X1.3 Tube in the H80 temper is recommended for applications in which there is a need for a tube as strong as technically feasible for the size indicated.

**X2. INTERNATIONAL ANNEALED COPPER STANDARD (ELECTRICAL CONDUCTIVITY EQUIVALENTS)**

Electrical Resistivity,  $\Omega\cdot\text{g}/\text{m}^2$

0.151 76  
0.153 28  
0.156 14  
0.157 37  
0.159 40  
0.170 31  
0.174 18

Conductivity, %

101.00  
100.00  
98.16  
97.40  
96.16  
90  
88

ASMENORMDOC.COM : Click to view the full PDF of ASME BPVC.II.B (ASME BPVC Section II part B) 2025

INTENTIONALLY LEFT BLANK

# SPECIFICATION FOR COPPER-SILICON ALLOY PLATE, SHEET, STRIP, AND ROLLED BAR FOR GENERAL PURPOSES AND PRESSURE VESSELS



**SB-96/SB-96M**

(Identical with ASTM Specification B96/B96M-20 except yield strength is required.)

ASMENORMDOC.COM :: Click to view the full PDF of ASME BPVC.II.B (ASME BPVC Section II part B) 2025

# Specification for Copper-Silicon Alloy Plate, Sheet, Strip, and Rolled Bar for General Purposes and Pressure Vessels

## 1. Scope

1.1 This specification establishes the requirements for copper-silicon alloy plate, sheet, strip, and rolled bar for drawing, forming, stamping, bending, and general engineering applications, and for pressure vessel applications. The alloys involved are copper alloys UNS Nos. C65100, C65400, and C65500.

1.2 When product is ordered for *ASME Boiler and Pressure Vessel Code* applications, consult the Code for applicable alloys.

1.3 *Units*—The values stated in either inch-pound units or SI units are to be regarded separately as standard. Within the text, SI units are shown in brackets. The values stated in each system are not necessarily exact equivalents; therefore, to ensure conformance with the standard, each system shall be used independently of the other, and values from the two systems shall not be combined.

1.4 *This international standard was developed in accordance with internationally recognized principles on standardization established in the Decision on Principles for the Development of International Standards, Guides and Recommendations issued by the World Trade Organization Technical Barriers to Trade (TBT) Committee.*

## 2. Referenced Documents

### 2.1 ASTM Standards:

B248 Specification for General Requirements for Wrought Copper and Copper-Alloy Plate, Sheet, Strip, and Rolled Bar

B248M Specification for General Requirements for Wrought Copper and Copper-Alloy Plate, Sheet, Strip, and Rolled Bar (Metric)

B846 Terminology for Copper and Copper Alloys

E8/E8M Test Methods for Tension Testing of Metallic Materials

E54 Test Methods for Chemical Analysis of Special Brasses and Bronzes (Withdrawn 2002)

E62 Test Methods for Chemical Analysis of Copper and Copper Alloys (Photometric Methods) (Withdrawn 2010)

E118 Test Methods for Chemical Analysis of Copper-Chromium Alloys (Withdrawn 2010)

E478 Test Methods for Chemical Analysis of Copper Alloys

2.2 *ASME Code:*

ASME Boiler and Pressure Vessel Code

## 3. General Requirements

3.1 The following sections of Specification B248 or Specification B248M constitute a part of this specification:

3.1.1 Terminology

3.1.2 Materials and Manufacture

3.1.3 Dimensions, Mass, and Permissible Variations

3.1.4 Workmanship, Finish, and Appearance

3.1.5 Sampling

3.1.6 Number of Tests and Retests

3.1.7 Test Specimens

3.1.8 Test Methods

3.1.9 Significance of Numerical Limits

3.1.10 Inspection

3.1.11 Rejection and Rehearing

3.1.12 Certification

3.1.13 Test Reports

3.1.14 Product Identification

3.1.15 Packing and Package Marking

3.1.16 Supplementary Requirements

3.2 In addition, when a section with a title identical to that referenced in 3.1 above appears in this specification, it contains additional requirements which supplement those appearing in Specification B248 or Specification B248M.

#### 4. Terminology

4.1 For definitions of terms related to copper and copper alloys, refer to Terminology B846.

#### 5. Ordering Information

5.1 Include the following specified choices when placing orders for product under this specification, as applicable:

- 5.1.1 ASTM designation and year of issue;
- 5.1.2 Copper [Alloy] UNS No. designation (Section 1);
- 5.1.3 Temper (Section 7);
- 5.1.4 Dimensions, Thickness, Width, and Length (Section 10);
- 5.1.5 How furnished: straight lengths or coils;
- 5.1.6 Quantity—total weight or total length or number of pieces of each size (10.7);
- 5.1.7 Intended application;
- 5.1.8 Finish (11.2); and
- 5.1.9 Type of edge, if required (slit, sheared, sawed, square corners, round corners, rounded edges, or full rounded edges) (10.6).

5.2 The following options are available but may not be included unless specified at the time of placing of the order when required.

- 5.2.1 DELETED
- 5.2.2 DELETED
- 5.2.3 If product is purchased for agencies of the U.S. government (see the Supplementary Requirements section of Specification B248 or Specification B248M for additional requirements, if specified);
- 5.2.4 DELETED
- 5.2.5 DELETED
- 5.2.6 Whether 0.2 % yield strength is required (Tables 1 and 2); and
- 5.2.7 If specification number must be shown on package marking.

#### 6. Chemical Composition

6.1 The material shall conform to the chemical composition requirements in Table 3 for the copper [alloy] UNS No. designation specified in the ordering information.

6.2 These composition limits do not preclude the presence of other elements. By agreement between the manufacturer and purchaser, limits may be established and analysis required for unnamed elements.

6.3 For alloys in which copper is listed as “remainder,” copper is the difference between the sum of results of all elements determined and 100 %. When all elements in Table 3 are determined, the sum of results shall be 99.5 % min.

#### 7. Temper

7.1 The standard tempers for products described in this specification are in Tables 1 and 2 and Tables 4 and 5.

- 7.1.1 Hot rolled temper M20.
- 7.1.2 Hot rolled and rerolled temper M25.
- 7.1.3 Cold rolled tempers H01 to H14.
- 7.1.4 Annealed tempers O50 or O61.

#### 8. Grain Size for Annealed Tempers

8.1 The approximate grain size values for annealed tempers given in Tables 1 and 2 and Tables 4 and 5 are for general information and shall not be used as a basis for product rejection.

#### 9. Mechanical Property Requirements

##### 9.1 Tensile Strength Requirements:

9.1.1 Product furnished under this specification shall conform to the tensile requirements prescribed in Table 1, Table 2, Table 4, or Table 5, when tested in accordance with Test Methods E8/E8M.

##### 9.1.2 DELETED

9.1.3 The tension test specimens shall be taken so the longitudinal axis of the specimens is parallel to the direction of rolling.

##### 9.2 Yield Strength Requirements:

9.2.1 Product furnished under this specification shall conform to the yield strength requirements prescribed in Tables 1 and 2 when tested in accordance with Test Methods E8/E8M. The purchaser must specify at the time of ordering which yield strength method shall be used.

##### 9.3 Elongation Requirements:

9.3.1 Product furnished under this specification shall be capable of conforming to the elongation requirements prescribed in Tables 1 and 2 when tested in accordance with Test Methods E8/E8M.

**TABLE 1 Tensile Strength Requirements and Approximate Rockwell Hardness and Grain Size Values for Pressure Vessel Applications (Inch-Pound Units)**

Temper Designation		Tensile Strength, ksi	Yield Strength at 0.5 % Extension Under Load, ksi min	Yield Strength <sup>A</sup> at 0.2 % offset, min, ksi	Elongation, min % <sup>B</sup>	Approximate Rockwell F Hardness	Approximate Grain Size, mm
Code	Name						
Copper Alloy UNS No. C65500							
O61	Annealed	50–67	18	18	40	70–82	0.110 max <sup>C</sup>

<sup>A</sup> See 5.2.6.

<sup>B</sup> Elongation in 2 in.

<sup>C</sup> No minimum grain size requirement is specified, but all annealed material shall be fully recrystallized.

**TABLE 2 Tensile Strength Requirements and Approximate Rockwell Hardness and Grain Size Values for Pressure Vessel Applications (SI Units)**

Temper Designation		Tensile Strength, MPa	Yield Strength at 0.5 % Extension Under Load, MPa min	Yield Strength <sup>A</sup> at 0.2 % offset, min, MPa	Elongation, min % <sup>B</sup>	Approximate Rockwell F Hardness	Approximate Grain Size, mm
Code	Name						
Copper Alloy UNS No. C65500							
O61	Annealed	345–460	125	125	40	70–82	0.110 max <sup>C</sup>

<sup>A</sup> See 5.2.6.

<sup>B</sup> Elongation in 50 mm.

<sup>C</sup> No minimum grain size requirement is specified, but all annealed material shall be fully recrystallized.

**TABLE 3 Chemical Requirements**

Element	Composition, %		
	Copper Alloy UNS No.		
	C65100	C65400	C65500
Copper, incl silver	remainder	remainder	remainder
Silicon	0.8–2.0	2.7–3.4	2.8–3.8
Manganese	0.7 max	...	0.50–1.3
Tin	...	1.2–1.9	...
Chromium	...	0.01–0.12	...
Zinc, max	1.5	0.50	1.5
Iron, max	0.8	...	0.8
Nickel, max <sup>A</sup>	...	...	0.6
Lead, max	0.05	0.05	0.05

<sup>A</sup> Incl cobalt.

**9.4 Rockwell Hardness Requirement:**

9.4.1 The approximate Rockwell hardness values given in Tables 1 and 2 and Tables 4 and 5 are for general information and assistance in testing, and shall not be used as a basis for product rejection.

**10. Dimensions, Mass, and Permissible Variation**

10.1 The dimensions and tolerances for product described by this specification shall be as specified in Specification B248 or Specification B248M with particular reference to the following tables and related paragraphs (exceptions for ASME Pressure Vessel Code applications are noted):

10.2 *Thickness*—Table 2.

10.2.1 *Pressure Vessel Code Applications*—The thickness of any plate or sheet shall not be more than 0.01 in. under the thickness specified.

10.3 *Width:*

10.3.1 *Slit Metal and Slit Metal with Rolled Edges*—Table 4.

10.3.2 *Square Sheared Metal*—Table 5.

10.3.3 *Sawed Metal*—Table 6.

10.4 *Length:*

10.4.1 *Length Tolerance for Straight Lengths*—Table 7.

10.4.2 *Schedule for Minimum Lengths and Maximum Weights of Ends for Specific Lengths with Ends, and Stock Lengths with Ends*—Table 8.

10.4.3 *Length Tolerances for Square Sheared Metal*—Table 9.

10.4.4 *Length Tolerances for Sawed Metal*—Table 10.

10.5 *Straightness:*

10.5.1 *Slit Metal or Slit Metal Either Straightened or Edge Rolled*—Table 11.

10.5.2 *Square Sheared Metal*—Table 12.

10.5.3 *Sawed Metal*—Table 13.

10.6 *Edges Contours:*

10.6.1 *Square Corners*—Table 14.

10.6.2 *Rounded Corners*—Table 15.

10.6.3 *Rounded Edges*—Table 16.

10.6.4 *Full-Rounded Edges*—Table 17.

10.7 *Weight:*

10.7.1 *Lot Weight Tolerances for Hot-Rolled Sheet and Plate*—Table 18.

10.7.2 *ASME Pressure Vessel Code Applications*—Table 6 of this specification.

**11. Workmanship, Finish, and Appearance**

11.1 For workmanship and appearance requirements, refer to Specification B248 or Specification B248M.

11.2 *Finish*—The material is supplied regularly in the following finishes:

11.2.1 *Black*—After hot rolling retains all of the oxides.

11.2.2 *Plain Pickled*—Sulfuric acid pickle only, brick red oxide; has cuprous and silicon oxides still adherent.

11.2.3 *Specially Cleaned*—Commercially free of all oxides; has the golden color of the alloy.

11.2.4 *Sand Blasted*—Commercially free of all oxides; has a dull gray color.

**12. Sampling**

12.1 Refer to sampling section in Specification B248 or Specification B248M.

**13. Test Methods**

13.1 *Chemical Analyses:*

13.1.1 In cases of disagreement, test methods for chemical analysis shall be subject to agreement between the manufacturer or supplier and the purchaser. The following table is a list of published test methods, some of which may no longer be viable, which along with others not listed, may be used subject to agreement.

Element	ASTM Test Method
Copper	E478
Silicon	E54; Perchloric acid dehydration
Manganese	E62
Tin	E478; Titrimetric
Chromium	E118
Zinc	E478; Atomic absorption
Iron	E478
Nickel	E478; Photometric
Lead	E478; Atomic absorption

**TABLE 4 Tensile Strength Requirements and Approximate Rockwell Hardness and Grain Size Values (Inch-Pound Units)**

Temper Designation		Tensile Strength, ksi	Approximate Rockwell Hardness		Approximate Grain Size, mm
Code	Name		F Scale	B Scale	
Copper Alloy UNS No. C65100					
O61	Annealed	38–45	45–55	...	0.050–0.120
O50	Light anneal	40–50	50–75	...	0.060 max <sup>A</sup>
H01	Quarter-hard	42–52	...	48–63	...
H02	Half-hard	47–57	...	64–73	...
H04	Hard	60–70	...	74–82	...
H06	Extra-hard	67–76	...	78–85	...
H08	Spring	71–79	...	81–86	...
Copper Alloy UNS Nos. C65500					
O61	Annealed	52–58	70–82	...	0.110 max <sup>A</sup>
O50	Light anneal	55–64	76–93	...	0.055 max <sup>B</sup>
H01	Quarter-hard	60–74	...	65–80	...
H02	Half-hard <sup>B</sup>	72–86	...	79–91	...
H04	Hard <sup>B</sup>	85–99	...	88–96	...
H06	Extra-hard <sup>B</sup>	95–109	...	93–98	...
H08	Spring <sup>B</sup>	102–116	...	94–99	...
M20	As hot-rolled	55–72	72 min	...	...
M25	As hot-rolled and rerolled	58–72	...	60–80	...
Copper Alloy UNS No. C65400			Superficial 30T	B Scale	
O61	Annealed	65–80	...	...	0.040 <sup>B</sup> max
H01	Quarter hard <sup>B</sup>	75–90	64–77	72–91	...
H02	Half hard <sup>B</sup>	86–101	75–79	89–95	...
H03	Three-quarter hard <sup>B</sup>	97–112	77–81	94–97	...
H04	Hard <sup>B</sup>	108–120	80–81	96–98	...
H06	Extra hard <sup>B</sup>	116–126	81–82	97–100	...
H08	Spring <sup>B</sup>	124–133	81–82	99–101	...
H10	Extra spring <sup>B</sup>	131–140	81 min	100–102	...
H14	Super spring <sup>B</sup>	137 min	81 min	101 min	...

<sup>A</sup> No minimum grain size requirement is specified, but all annealed material shall be fully recrystallized.

<sup>B</sup> Commercially supplied only as strip. The manufacturer should be consulted where these tempers are desired in sheet or plate.

**TABLE 5 Tensile Strength Requirements and Approximate Rockwell Hardness and Grain Size Values (SI Units)**

Temper Designation		Tensile Strength, MPa	Approximate Rockwell Hardness		Approximate Grain Size, mm
Code	Name		F Scale	B Scale	
Copper Alloy UNS No. C65100					
O61	Annealed	260–310	45–55	...	0.050–0.120
O50	Light anneal	275–345	50–75	...	0.060 max <sup>A</sup>
H01	Quarter-hard	290–360	...	48–63	...
H02	Half-hard	325–395	...	64–73	...
H04	Hard	415–485	...	74–82	...
H06	Extra-hard	460–525	...	78–85	...
H08	Spring	490–545	...	81–86	...
Copper Alloy UNS Nos. C65500					
O61	Annealed	360–400	70–82	...	0.110 max <sup>A</sup>
O50	Light anneal	380–440	76–93	...	0.055 max <sup>B</sup>
H01	Quarter-hard	415–510	...	65–80	...
H02	Half-hard <sup>B</sup>	495–595	...	79–91	...
H04	Hard <sup>B</sup>	585–685	...	88–96	...
H06	Extra-hard <sup>B</sup>	655–750	...	93–98	...
H08	Spring <sup>B</sup>	705–800	...	94–99	...
M20	As hot-rolled	380–495	72 min	...	...
M25	As hot-rolled and rerolled	400–495	...	60–80	...
Copper Alloy UNS No. C65400			Superficial 30T	B Scale	
O61	Annealed	450–550	...	...	0.040 <sup>B</sup> max
H01	Quarter hard <sup>B</sup>	515–620	64–77	72–91	...
H02	Half hard <sup>B</sup>	595–695	75–79	89–95	...
H03	Three-quarter hard <sup>B</sup>	670–770	77–81	94–97	...
H04	Hard <sup>B</sup>	745–825	80–81	96–98	...
H06	Extra hard <sup>B</sup>	800–870	81–82	97–100	...
H08	Spring <sup>B</sup>	855–915	81–82	99–101	...
H10	Extra spring <sup>B</sup>	905–965	81 min	100–102	...
H14	Super spring <sup>B</sup>	945 min	81 min	101 min	...

<sup>A</sup> No minimum grain size requirement is specified, but all annealed material shall be fully recrystallized.

<sup>B</sup> Commercially supplied only as strip. The manufacturer should be consulted where these tempers are desired in sheet or plate.

13.1.2 Test method(s) to be followed for the determination of element(s) resulting from contractual or purchase order

agreement shall be as agreed upon between the manufacturer or supplier and purchaser.

**TABLE 6 Lot Weight Tolerances in Percentage of Theoretical Weight for Pressure Vessel Applications—All Plus**

Thickness, in. [mm]	Permissible Excess in Average Weight of Lots, Expressed in Percentage of Normal Weight					
	48 in. [1200 mm] and Under in Width	Over 48 to 60 in. [1200 to 1500 mm] in Width	Over 60 to 72 in. [1500 to 1800 mm] in Width	Over 72 to 96 in. [1800 to 2500 mm] in Width	Over 96 to 120 in. [2500 to 3000 mm] in Width	Over 120 to 132 in. [3000 to 3500 mm] incl in Width
1/8 to 3/16, incl [3.0 to 5.0]	6.5	8	9	11	12	13
Over 3/16 to 1/4, incl [6.0 to 8.0]	6.5	8	9	11	12	13
Over 1/4 to 5/16, incl [8.0 to 10]	6.5	7.75	8.75	11	12	13
Over 5/16 to 3/8, incl [9.0 to 10]	6.25	7.5	8.5	11	12	13
Over 3/8 to 7/16, incl [10 to 12]	6	7.25	8.25	11	12	13
Over 7/16 to 1/2, incl [12 to 14]	6	7	8	10	11	12
Over 1/2 to 5/8, incl [14 to 16]	5.75	6.5	7.5	9	10	11
Over 5/8 to 3/4, incl [16 to 20]	5.5	6	7	8	9	10
Over 3/4 to 1, incl [20 to 25]	5	5	6.25	7	8	9
Over 1 to 2, incl [25 to 50]	3.5	4	5	6	7	8

13.2 Other Tests:

13.2.1 Mechanical Properties (Tensile Strength, Yield Strength, Elongation, Rockwell Hardness, and Grain Size)—Refer to the appropriate test method in Specification B248 or Specification B248M.

14. Keywords

14.1 copper-silicon alloy plate; copper-silicon alloy pressure vessels; copper-silicon alloy rolled bar; copper-silicon alloy sheet; copper-silicon alloy strip; UNS No. C65100; UNS No. C65400; UNS No. C65500

ASME BPVC Section II part B) 2025

ASME BPVC.II.B

Click to view the full PDF of ASME BPVC.II.B

## SPECIFICATION FOR COPPER-SILICON ALLOY ROD, BAR AND SHAPES



**SB-98/SB-98M**

(Identical with ASTM Specification B98/B98M-13(2019) except that paras. 4.2.3 and 8.1.1.1 were deleted so that tensile testing rather than Rockwell hardness testing is required to show conformance with mechanical properties.)

ASMENORMDOC.COM : Click to view the full PDF of ASME BPVC.II.B (ASME BPVC Section II part B) 2025

# Specification for Copper-Silicon Alloy Rod, Bar and Shapes

## 1. Scope

1.1 This specification establishes requirements for copper-silicon rod, bar, and shapes for UNS Copper Alloys C65100, C65500, and C66100.

NOTE 1—Material for hot forging is covered by Specification B124/B124M.

NOTE 2—DELETED

1.2 *Units*—The values stated in either SI units or inch-pound units are to be regarded separately as standard. Within the text, SI units are shown in brackets. The values stated in each system are not necessarily exact equivalents; therefore, to ensure conformance with the standard, each system shall be used independently of the other and values from the two systems shall not be combined.

1.3 *This international standard was developed in accordance with internationally recognized principles on standardization established in the Decision on Principles for the Development of International Standards, Guides and Recommendations issued by the World Trade Organization Technical Barriers to Trade (TBT) Committee.*

## 2. Referenced Documents

### 2.1 ASTM Standards:

B124/B124M Specification for Copper and Copper Alloy Forging Rod, Bar, and Shapes

B249/B249M Specification for General Requirements for Wrought Copper and Copper-Alloy Rod, Bar, Shapes and Forgings

B950 Guide for Editorial Procedures and Form of Product Specifications for Copper and Copper Alloys

B601 Classification for Temper Designations for Copper and

Copper Alloys—Wrought and Cast

E8/E8M Test Methods for Tension Testing of Metallic Materials

E18 Test Methods for Rockwell Hardness of Metallic Materials

E62 Test Methods for Chemical Analysis of Copper and Copper Alloys (Photometric Methods) (Withdrawn 2010)

E478 Test Methods for Chemical Analysis of Copper Alloys

2.2 *ASME Standard:*

ASME Boiler and Pressure Vessel Code

## 3. General Requirements

3.1 The following sections of Specification B249/B249M constitute a part of this specification:

3.1.1 Terminology;

3.1.2 Materials and Manufacture;

3.1.3 Workmanship, Finish, and Appearance;

3.1.4 Sampling;

3.1.5 Number of Tests and Retests;

3.1.6 Specimen Preparation;

3.1.7 Test Methods;

3.1.8 Significance of Numerical Limits;

3.1.9 Inspection;

3.1.10 Rejection and Rehearing;

3.1.11 Certification;

3.1.12 Test Reports;

3.1.13 Packaging and Package Marking; and

3.1.14 Supplementary Requirements.

3.2 In addition, when a section with a title identical to one of those referenced in 3.1 appears in this specification, it contains additional requirements that supplement those which appear in Specification B249/B249M.

## 4. Ordering Information

4.1 Include the following specified choices when placing orders for product under this specification, as applicable:

4.1.1 ASTM Designation and year of issue;

- 4.1.2 Copper Alloy UNS No. designation;  
 4.1.3 Temper designation (see Temper Section 7);  
 4.1.4 Quantity; total weight or length, or number of pieces of each temper, form, or alloy;  
 4.1.5 Dimensions; diameter or distance between parallel surfaces;  
 4.1.6 Type of edge; edge contours;  
 4.1.7 How furnished; specific lengths with or without ends; and  
 4.1.8 Intended application.

4.2 The following options are available but may not be included unless specified at the time of placing of the order when required:

- 4.2.1 DELETED  
 4.2.2 DELETED  
 4.2.3 DELETED

4.2.4 If product is purchased for agencies of the U.S. Government (see Supplementary Requirements in Specification B249/B249M).

## 5. Material and Manufacture

5.1 *Materials*—The starting material shall be cast billets or rods of Copper Alloy UNS Nos. C65100, C65500, or C66100, and shall be of such soundness and structure as to enable them to be processed into the product specified in the contract or purchase order.

5.2 *Manufacture*—The product shall be manufactured by such hot-working, cold-working, straightening, and annealing processing as to produce a uniform wrought structure and obtain the required finish properties.

## 6. Chemical Composition

6.1 The material shall conform to the chemical requirements specified in Table 1 for the Copper Alloy UNS No. designated in the ordering information.

6.1.1 For alloys in which copper is listed as “remainder,” copper is the difference between the sum of the results of all elements determined and 100 %.

6.1.2 When all elements listed in Table 1 are determined for the designated alloy, the sum of results shall be 99.5 % min.

**TABLE 1 Chemical Requirements**

	Composition, % Maximum (Unless Shown as a Range or Minimum)		
	Copper Alloy UNS No.		
	C65100	C65500	C66100
Copper (Includes Silver)	remainder	remainder	remainder
Lead	0.05	0.05	0.20–0.8
Iron	0.8	0.8	0.25
Zinc	1.5	1.5	1.5
Manganese	0.7	0.50–1.3	1.5
Silicon	0.8–2.0	2.8–3.8	2.8–3.5
Nickel (includes cobalt)	...	0.6	...

6.2 These composition limits do not preclude the presence of other elements. Limits may be established and analysis required for unnamed elements by agreement between the manufacturer and the purchaser.

## 7. Temper

7.1 The standard tempers, as defined in Classification B601, for products described in this specification are given in Tables 2-5.

- 7.1.1 Soft annealed O60,  
 7.1.2 ¼-hard H01,  
 7.1.3 ½-hard H02,  
 7.1.4 Hard H04,  
 7.1.5 Extra-hard H06,  
 7.1.6 As hot rolled M20, and  
 7.1.7 As hot extruded M30.

7.2 Product of bars and shapes in the temper H06 is normally not produced.

## 8. Mechanical Property Requirements

8.1 Product furnished under this specification shall conform to the tensile and hardness requirements prescribed in Tables 2-5 for the Copper Alloy UNS No. designation specified in the ordering information.

8.1.1 *Rockwell Hardness Requirement*—For the alloys and tempers listed, product 0.5 in. [12 mm] and over in diameter or in the distance between parallel surfaces shall conform with the requirements given in Table 4 and Table 5, when tested in accordance with Test Methods E18.

8.1.1.1 DELETED

8.1.2 *Tensile Strength Requirements*—The product shall conform with the requirements of Table 2 and Table 3 when tested in accordance with Test Methods E8/E8M.

8.1.2.1 The tensile requirements for all alloys and forms of M20 and M30 tempers shall be as agreed upon between the manufacturer and purchaser at the time of order.

## 9. Dimensions, Mass and Permissible Variations

9.1 Refer to the appropriate paragraphs in Specification B249/B249M with particular reference to the following tables:

9.2 *Diameter or Distance Between Parallel Surfaces:*

9.2.1 *Rod: Round, Hexagonal, Octagonal*—Refer to Table 1 for Alloy C65100 and to Table 2 for Alloys C65500 and C66100.

9.2.2 *Rod: Round M20 Temper*—Refer to Table 6.

9.2.3 *Rod: Round, Hexagonal, Octagonal, M30 Temper*—Refer to Table 5.

9.2.4 *Bar: Rectangular and Square*—Refer to Tables 8 and 10 for Alloy C65100, and Tables 9 and 11 for Alloys C65500 and C66100.

9.2.5 *Bar: M30 Temper*—Refer to Table 5 for thickness and width tolerances.

9.3 *Shapes*—The dimensional tolerance for shapes shall be as agreed upon between the manufacturer and the purchaser, and shall be specified in the order.

TABLE 2 Tensile Requirements, Inch-Pound (see Table 3 for SI)

Temper Designation		Diameter or Distance Between Parallel Surfaces, <sup>A</sup> in.	Tensile Strength min, ksi	Yield Strength at 0.5 % Extension Under Load, min, ksi	Elongation in 4 x Diameter or Thickness of Specimen, min, % <sup>B</sup>
Code	Name				
Copper Alloy UNS No. C65100 Rods, Bars, and Shapes					
O60	Soft anneal	All forms, all sizes	40	12	30
H02	Half-hard	Rods:			
		Up to 1/2, incl	55	20	11
		Over 1/2 to 2, incl	55	20	12
H04	Hard	Bars and shapes	c	c	c
		Rods:			
		Up to 1/2, incl	65	35	8
H06	Extra-hard	Over 1/2 to 2, incl	65	35	10
		Bars and shapes	c	c	c
		Rods:			
H06	Extra-hard	Up to 1/2, incl	85	55	6
		Over 1/2 to 1, incl	75	45	8
		Over 1 to 1 1/2, incl	75	40	8
Copper Alloy UNS Nos. C65500 and C66100 Rectangular Bars					
O60	Soft anneal	All sizes	52	15	35
H04	Hard	Up to 1, incl	65	38	20
		Over 1 to 1 1/2, incl	60	30	25
		Over 1 1/2 to 3, incl	55	24	27
Copper Alloy UNS Nos. C65500 and C66100 Rods, Square Bars, and Shapes					
O60	Soft anneal	All forms, all sizes	52	15	35
H01	Quarter-hard	All forms, all sizes	55	24	25
H02	Half-hard	Rods and square bars:			
		Up to 2, incl	70	38	20
		Shapes	c	c	c
H04	Hard	Rods and square bars:			
		Up to 1/4, incl	90	55	8
		Over 1/4 to 1, incl	90	52	13
		Over 1 to 1 1/2, incl	80	43	15
		Over 1 1/2 to 3, incl	70	38	17
		Over 3	c	c	c
H06	Extra-hard	Shapes	c	c	c
		Rods: up to 1/2, incl	100	55	7

<sup>A</sup> For rectangular bar, the Distance Between Parallel Surfaces refers to thickness.  
<sup>B</sup> In any case a minimum gage length of 1 in. shall be used.  
<sup>C</sup> As agreed upon between manufacturer and purchaser.

9.4 Length:

9.4.1 Rod, Bar and Shapes—Refer to Tables 13 and 15.

9.5 Straightness:

9.5.1 Rod and Bar—Refer to Table 16.

9.6 Edge Contours:

9.6.1 Rod and Bar—Refer to the section entitled, “Edge Contours” and to Figs. 1, 2, and 3.

10. Test Methods

10.1 In cases of disagreement, test methods for chemical composition shall be subject to agreement between the manufacturer or supplier and the purchaser. The following table is a list of published test methods some of which are considered by ASTM as no longer viable. These, and others not listed, may be used subject to agreement.

Element	Test Methods
Copper	E478
Lead	E478, Atomic absorption
Manganese	E62
Nickel	E478, Photometric
Silicon	E62
Zinc	E478, Atomic absorption

10.1.1 Test Method(s) to be followed for the determination of elements required by contractual or purchase order agreement shall be as agreed upon between the supplier and purchaser.

10.2 Refer to Specification B249/B249M for other appropriate test methods.

11. Keywords

11.1 copper—rod, bar, shapes; copper-silicon alloy; high silicon bronze A; low silicon bronze B; silicon bronze; UNS No. C65100; UNS No. C65500; UNS No. C66100

**TABLE 3 Tensile Requirements, SI (see Table 2 for Inch-Pound)**

Temper Designation		Diameter or Distance Between Parallel Surfaces, <sup>A</sup> mm	Tensile Strength min, MPa	Yield Strength at 0.5 % Extension Under Load, min, MPa	Elongation, min, % <sup>B</sup>
Code	Name				
Copper Alloy UNS No. C65100 Rods, Bars, and Shapes					
O60	Soft anneal	All forms, all sizes	275	85	30
H02	Half-hard	Rods:			
		Up to 12, incl	380	140	11
		Over 12 to 50, incl	380	140	12
H04	Hard	Bars and shapes	<i>c</i>	<i>c</i>	<i>c</i>
		Rods:			
		Up to 12, incl	450	240	8
H06	Extra-hard	Over 12 to 50, incl	450	240	10
		Bars and shapes	<i>c</i>	<i>c</i>	<i>c</i>
		Rods:			
		Up to 12, incl	585	380	6
		Over 12 to 25, incl	515	310	8
		Over 25 to 38, incl	515	275	8
Copper Alloy UNS Nos. C65500 and C66100 Rectangular Bars					
O60	Soft anneal	All sizes	360	105	35
H04	Hard	Up to 25, incl	450	260	20
		Over 25 to 38, incl	415	205	25
		Over 38 to 75, incl	380	165	27
Copper Alloy UNS Nos. C65500 and C66100 Rods, Square Bars, and Shapes					
O60	Soft anneal	All forms, all sizes	360	105	35
H01	Quarter-hard	All forms, all sizes	380	165	25
H02	Half-hard	Rods and square bars:			
		Up to 50, incl	485	260	20
H04	Hard	Shapes	<i>c</i>	<i>c</i>	<i>c</i>
		Rods and square bars:			
		Up to 6, incl	615	380	8
		Over 6 to 25, incl	615	360	13
		Over 25 to 38, incl	545	295	15
		Over 38 to 75, incl	485	260	17
		Over 75	<i>c</i>	<i>c</i>	<i>c</i>
H06	Extra-hard	Shapes	<i>c</i>	<i>c</i>	<i>c</i>
		Rods: up to 12, incl	690	380	7

<sup>A</sup> For rectangular bar, the Distance Between Parallel Surfaces refers to thickness.

<sup>B</sup> Elongation values are based on a gage length of 5.65 times the square root of the area for dimensions greater than 2.5 mm.

<sup>C</sup> As agreed upon between manufacturer and purchaser.

**TABLE 4 Rockwell Hardness Requirements, Inch-Pound<sup>A</sup> (see Table 5 for SI)**

Temper Designation		Diameter or Distance Between Parallel Surfaces, <sup>B</sup> in.	Rockwell B Hardness Determined on the Cross Section Midway Between Surface and Center
Code	Name		
Copper Alloy UNS No. C65100 Rods, Bars, and Shapes			
H02	Half-hard	0.5 to 2.0, incl	60–85
H04	Hard	0.5 to 2.0, incl	65–90
H06	Extra-hard <sup>C</sup>	0.5 to 1.5, incl	75–95
Copper Alloy UNS Nos. C65500 and C66100 Rectangular Bars			
H04	Hard	0.5 to 3.0, incl	60–95
Copper Alloy UNS Nos. C65500 and C66100 Rods, Square Bars, and Shapes			
H02	Half-hard	0.5 to 1.0, incl	75–95
		over 1.0 to 1.5, incl	75–95
		over 1.5 to 3.0, incl	75–95
H04	Hard	0.5 to 1.0, incl	85–100
		over 1.0 to 1.5, incl	80–95
		over 1.5 to 3.0, incl	75–95

<sup>A</sup> Rockwell hardness requirements are not established for diameters less than 0.5 in.

<sup>B</sup> For rectangular bar, the Distance Between Parallel Surfaces refers to thickness.

<sup>C</sup> Bars and shapes are not produced in the H06 temper.

**TABLE 5 Rockwell Hardness Requirements, SI<sup>A</sup> (see Table 4 for Inch-Pound)**

Temper Designation		Diameter or Distance Between Parallel Surfaces, <sup>B</sup> mm	Rockwell B Hardness Determined on the Cross Section Midway Between Surface and Center
Code	Name		
Copper Alloy UNS No. C65100 Rods, Bars, and Shapes			
H02	Half-hard	12 to 50, incl	60–85
H04	Hard	12 to 50, incl	65–90
H06	Extra-hard <sup>C</sup>	12 to 50, incl	75–95
Copper Alloy UNS Nos. C65500 and C66100 Rectangular Bars			
H04	Hard	12 to 75, incl	60–95
Copper Alloy UNS Nos. C65500 and C66100 Rods, Square Bars, and Shapes			
H02	Half-hard	12 to 25, incl	75–95
		over 25 to 38, incl	75–95
		over 38 to 75, incl	75–95
H04	Hard	12 to 25, incl	85–100
		over 25 to 38, incl	80–95
		over 38 to 75, incl	75–95

<sup>A</sup> Rockwell hardness requirements are not established for diameters less than 12 mm.

<sup>B</sup> For rectangular bar, the Distance Between Parallel Surfaces refers to thickness.

<sup>C</sup> Bars and shapes are not produced in the H06 temper.

ASMENORMDOC.COM : Click to view the full PDF of ASME BPVC.II.B (ASME BPVC Section II part B) 2025

## SPECIFICATION FOR ALUMINUM-ALLOY PERMANENT MOLD CASTINGS



**SB-108/SB-108M**

(Identical with ASTM Specification B108/B108M-12<sup>1</sup> except that certification and test reports have been made mandatory, and ASME welding requirements are invoked for repair welding.)

ASMENORMDOC.COM : Click to view the full PDF of ASME BPVC.II.B (ASME BPVC Section II part B) 2025

# Specification for Aluminum-Alloy Permanent Mold Castings

## 1. Scope

1.1 This specification covers aluminum-alloy permanent mold castings designated as shown in Table 1.

1.2 This specification is for aluminum-alloy permanent mold castings used in general purpose applications. It may not address the mechanical properties, integrity testing, and verification required for highly loaded or safety critical applications.

1.3 Alloy and temper designations are in accordance with ANSI H35.1/H35.1(M). The equivalent unified numbering system alloy designations are in accordance with Practice E527.

1.4 Unless the order specifies the “M” specification designation, the material shall be furnished to the inch-pound units.

1.5 For acceptance criteria for inclusion of new aluminum and aluminum alloys and their properties in this specification, see Annex A1 and Annex A2.

1.6 *Units*—The values stated in either SI units or inch-pound units are to be regarded separately as standard. The values stated in each system may not be exact equivalents; therefore, each system shall be used independently of the other. Combining values from the two systems may result in non-conformance with the standard.

1.7 *This standard does not purport to address all of the safety concerns, if any, associated with its use. It is the responsibility of the user of this standard to establish appropriate safety and health practices and determine the applicability of regulatory limitations prior to use.*

## 2. Referenced Documents

2.1 The following documents of the issue in effect on the date of casting purchase form a part of this specification to the extent referenced herein:

### 2.2 ASTM Standards:

- B179 Specification for Aluminum Alloys in Ingot and Molten Forms for Castings from All Casting Processes
- B275 Practice for Codification of Certain Nonferrous Metals and Alloys, Cast and Wrought
- B557 Test Methods for Tension Testing Wrought and Cast Aluminum- and Magnesium-Alloy Products
- B557M Test Methods for Tension Testing Wrought and Cast Aluminum- and Magnesium-Alloy Products (Metric)
- B660 Practices for Packaging/Packing of Aluminum and Magnesium Products
- B881 Terminology Relating to Aluminum- and Magnesium-Alloy Products
- B917/B917M Practice for Heat Treatment of Aluminum-Alloy Castings from All Processes
- D3951 Practice for Commercial Packaging
- E29 Practice for Using Significant Digits in Test Data to Determine Conformance with Specifications
- E34 Test Methods for Chemical Analysis of Aluminum and Aluminum-Base Alloys
- E94 Guide for Radiographic Examination
- E155 Reference Radiographs for Inspection of Aluminum and Magnesium Castings
- E165 Practice for Liquid Penetrant Examination for General Industry
- E527 Practice for Numbering Metals and Alloys in the Unified Numbering System (UNS)
- E607 Test Method for Atomic Emission Spectrometric Analysis Aluminum Alloys by the Point to Plane Technique Nitrogen Atmosphere (Withdrawn 2011)

TABLE 1 Chemical Composition Limits<sup>A,B,C</sup>

Alloy		Composition, %												Other Elements <sup>E</sup>	
ANSI <sup>D</sup>	UNS	Aluminum	Silicon	Iron	Copper	Manga- nese	Magne- sium	Chromium	Nickel	Zinc	Titanium	Tin	Each	Total <sup>F</sup>	
204.0	A02040	remainder	0.20	0.35	4.2–5.0	0.10	0.15–0.35	...	0.05	0.10	0.15–0.30	0.05	0.05	0.15	
242.0	A02420	remainder	0.7	1.0	3.5–4.5	0.35	1.2–1.8	0.25	1.7–2.3	0.35	0.25	...	0.05	0.15	
296.0		remainder	2.0–3.0	1.2	4.0–5.0	0.35	0.05	...	0.35	0.50	0.25	...	...	0.35	
308.0		remainder	5.0–6.0	1.0	4.0–5.0	0.50	0.10	...	...	1.0	0.25	...	...	0.50	
319.0	A03190	remainder	5.5–6.5	1.0	3.0–4.0	0.50	0.10	...	0.35	1.0	0.25	...	...	0.50	
332.0 <sup>G</sup>	A03320	remainder	8.5–10.5	1.2	2.0–4.0	0.50	0.50–1.5	...	0.50	1.0	0.25	...	...	0.50	
333.0	A03330	remainder	8.0–10.0	1.0	3.0–4.0	0.50	0.05–0.50	...	0.50	1.0	0.25	...	...	0.50	
336.0 <sup>G</sup>	A03360	remainder	11.0–13.0	1.2	0.50–1.5	0.35	0.7–1.3	...	2.0–3.0	0.35	0.25	...	0.05	...	
354.0	A03540	remainder	8.6–9.4	0.20	1.6–2.0	0.10	0.40–0.6	...	...	0.10	0.20	...	0.05	0.15	
355.0	A03550	remainder	4.5–5.5	0.6 <sup>H</sup>	1.0–1.5	0.50 <sup>H</sup>	0.40–0.6	0.25	...	0.35	0.25	...	0.05	0.15	
C355.0	A33550	remainder	4.5–5.5	0.20	1.0–1.5	0.10	0.40–0.6	...	...	0.10	0.20	...	0.05	0.15	
356.0	A03560	remainder	6.5–7.5	0.6 <sup>H</sup>	0.25	0.35 <sup>H</sup>	0.20–0.45	...	...	0.35	0.25	...	0.05	0.15	
A356.0	A13560	remainder	6.5–7.5	0.20	0.20	0.10	0.25–0.45	...	...	0.10	0.20	...	0.05	0.15	
357.0		remainder	6.5–7.5	0.15	0.05	0.03	0.45–0.6	...	...	0.05	0.20	...	0.05	0.15	
A357.0	A13570	remainder	6.5–7.5	0.20	0.20	0.10	0.40–0.7	...	...	0.10	0.04–0.20	...	0.05 <sup>I</sup>	0.15	
E357.0		remainder	6.5–7.5	0.10	...	0.10	0.55–0.6	...	...	...	0.10–0.20	...	0.05 <sup>J</sup>	0.15	
F357.0		remainder	6.5–7.5	0.10	0.20	0.10	0.40–0.7	...	...	0.10	0.04–0.20	...	0.05 <sup>J</sup>	0.15	
359.0	A03590	remainder	8.5–9.5	0.20	0.20	0.10	0.50–0.7	...	...	0.10	0.20	...	0.05	0.15	
443.0	A04430	remainder	4.5–6.0	0.8	0.6	0.50	0.05	0.25	...	0.50	0.25	...	...	0.35	
B443.0	A24430	remainder	4.5–6.0	0.8	0.15	0.35	0.05	...	...	0.35	0.25	...	0.05	0.15	
A444.0	A14440	remainder	6.5–7.5	0.20	0.10	0.10	0.05	...	...	0.10	0.20	...	0.05	0.15	
513.0 <sup>G</sup>	A05130	remainder	0.30	0.40	0.10	0.30	3.5–4.5	...	...	1.4–2.2	0.20	...	0.05	0.15	
535.0	A05350	remainder	0.15	0.15	0.05	0.10–0.25	6.2–7.5	...	...	...	0.10–0.25	...	0.05 <sup>K</sup>	0.15	
705.0	A07050	remainder	0.20	0.8	0.20	0.40–0.6	1.4–1.8	0.20–0.40	...	2.7–3.3	0.25	...	0.05	0.15	
707.0	A07070	remainder	0.20	0.8	0.20	0.40–0.6	1.8–2.4	0.20–0.40	...	4.0–4.5	0.25	...	0.05	0.15	
711.0 <sup>G</sup>	A07110	remainder	0.30	0.7–1.4	0.35–0.65	0.05	0.25–0.45	...	...	6.0–7.0	0.20	...	0.05	0.15	
713.0	A07130	remainder	0.25	1.1	0.40–1.0	0.6	0.20–0.50	0.35	0.15	7.0–8.0	0.25	...	0.10	0.25	
850.0	A08500	remainder	0.7	0.7	0.7–1.3	0.10	0.10	...	0.7–1.3	...	0.20	5.5–7.0	...	0.30	
851.0 <sup>G</sup>	A08510	remainder	2.0–3.0	0.7	0.7–1.3	0.10	0.10	...	0.3–0.7	...	0.20	5.5–7.0	...	0.30	
852.0 <sup>G</sup>	A08520	remainder	0.40	0.7	1.7–2.3	0.10	0.6–0.9	...	0.9–1.5	...	0.20	5.5–7.0	...	0.30	

<sup>A</sup> When single units are shown, these indicate the maximum amounts permitted.  
<sup>B</sup> Analysis shall be made for the elements for which limits are shown in this table.  
<sup>C</sup> The following applies to all specified limits in this table: For purposes of determining conformance to these limits, an observed value or a calculated value obtained from analysis shall be rounded to the nearest unit in the last right-hand place of figures used in expressing the specified limit in accordance with the rounding method of Practice E29.  
<sup>D</sup> ASTM alloy designations are recorded in Practice B275.  
<sup>E</sup> *Others* includes listed elements for which no specific limit is shown as well as unlisted metallic elements. The producer may analyze samples for trace elements not specified in the specification. However, such analysis is not required and may not cover all metallic *Others* elements. Should any analysis by the producer or the purchaser establish that an *Others* element exceeds the limit of *Each* or that the aggregate of several *Others* elements exceeds the limit of *Total*, the material shall be considered nonconforming.  
<sup>F</sup> *Other Elements*—Total shall be the sum of unspecified metallic elements 0.010 % or more, rounded to the second decimal before determining the sum.  
<sup>G</sup> 336.0 formerly A332.0, 332.0 formerly F332.0, 513.0 formerly A514.0, 711.0 formerly C712.0, 851.0 formerly A850.0, 852.0 formerly B850.0.  
<sup>H</sup> If the iron content exceeds 0.45 %, manganese content shall not be less than one half of the iron.  
<sup>I</sup> Beryllium 0.04–0.07.  
<sup>J</sup> Beryllium 0.002 max  
<sup>K</sup> Beryllium 0.003–0.007, boron 0.005 max.

E716 Practices for Sampling and Sample Preparation of Aluminum and Aluminum Alloys for Determination of Chemical Composition by Spectrochemical Analysis  
 E1251 Test Method for Analysis of Aluminum and Aluminum Alloys by Spark Atomic Emission Spectrometry  
 E2422 Digital Reference Images for Inspection of Aluminum Castings  
 IEEE/ASTM SI 10 Standard for Use of the International System of Units (SI): The Modern Metric System  
 2.3 *ANSI Standard:*  
 H35.1/H35.1M Alloy and Temper Designation Systems for Aluminum

2.4 *Military Standards:*  
 MIL-STD-129 Marking for Shipment and Storage  
 MIL-STD-276 Impregnation of Porous Nonferrous Metal Castings  
 NAVSEA S9074-AR-GIB-010/278 Requirements for Fabrication Welding and Inspection, and Casting Inspection and Repair for Machinery, Piping, and Pressure Vessels  
 2.5 *AMS Specification:*  
 AMS 2771 Heat Treatment of Aluminum Alloy Castings

2.6 Federal Standard:

Fed Std. No. 123 Marking for Shipment (Civil Agencies)

2.7 Other Standards:

CEN EN 14242 Aluminum and Aluminum Alloys, Chemical Analysis, Inductively Coupled Plasma Optical Emission Spectral Analysis

3. Terminology

3.1 Definitions—Refer to Terminology B881 for definitions of product terms used in this specification.

4. Ordering Information

4.1 Orders for material under this specification shall include the following information (see 1.4 and 1.5):

4.1.1 This specification designation (which includes the number, the year, and the revision letter, if applicable),

NOTE 1—For inch-pound application, specify Specification B108 and for metric application specify Specification B108M. Do not mix units.

4.1.2 Alloy (see Section 7 and Table 1),

4.1.3 Temper (see Section 10 and Table 2 [Table 3]).

TABLE 2 Tensile Requirements<sup>A</sup> (Inch-Pound Units)

NOTE 1—For purposes of determining conformance with this specification, each value for tensile strength and yield strength shall be rounded to the nearest 0.1 ksi, and each value for elongation shall be rounded to the nearest 0.5 %, both in accordance with the rounding method of Practice E29.

Alloy		Temper <sup>B</sup>	Tensile Strength, min, ksi	Yield Strength <sup>C</sup> (0.2 % offset), min, ksi	Elongation in 2 in. or 4 x Diameter, min, %	Typical Brinell Hardness <sup>D</sup> 500-kgf load, 10-mm ball
ANSI <sup>E</sup>	UNS					
204.0	A02040	T4 separately cast specimens	48.0	29.0	8.0	...
242.0	A02420	T571	34.0	...	F	105
		T61	40.0	...	F	110
296.0	A02960	T4	33.0	15.0	4.5	75
		T6	35.0	...	2.0	90
		T7	33.0	16.0	3.0	...
308.0	A03080	F	24.0	...	...	70
319.0	A03190	F	27.0	14.0	2.5	95
332.0 <sup>G</sup>	A03320	T5	31.0	...	F	105
333.0	A03330	F	28.0	...	F	90
		T5	30.0	...	F	100
		T6	35.0	...	F	105
		T7	31.0	...	F	90
336.0 <sup>G</sup>	A03360	T551	31.0	...	F	105
		T65	40.0	...	F	125
354.0	A03540	T61	48.0	37.0	3.0	...
		separately cast specimens	47.0	36.0	3.0	...
		castings, designated area <sup>H</sup>	43.0	33.0	2.0	...
		castings, no location designated <sup>H</sup>	52.0	42.0	2.0	...
		T62	50.0	42.0	2.0	...
		separately cast specimens	43.0	33.0	2.0	...
		castings, designated area <sup>H</sup>	27.0	...	F	75
355.0	A03550	T51	27.0	...	F	105
		T62	42.0	...	F	90
		T7	36.0	...	F	80
		T71	34.0	27.0	F	...
C355.0	A33550	T61	40.0	30.0	3.0	85–90
		separately cast specimens	40.0	30.0	3.0	...
		castings, designated area <sup>H</sup>	37.0	30.0	1.0	85
		castings, no location designated <sup>H</sup>	21.0	10.0	3.0	...
356.0	A03560	F	33.0	22.0	3.0	85
		T6	25.0	...	3.0	70
		T71	38.0	26.0	5.0	80–90
A356.0	A13560	T61	33.0	26.0	5.0	...
		separately cast specimens	28.0	26.0	3.0	...
		castings, designated area <sup>H</sup>	45.0	...	3.0	...
		castings, no location designated <sup>H</sup>	45.0	36.0	3.0	100
357.0		T6	46.0	36.0	3.0	...
A357.0	A13570	T61	41.0	31.0	3.0	...
		separately cast specimens	45.0	36.0	3.0	100
		castings, designated area <sup>H</sup>	46.0	36.0	3.0	...
		castings, no location designated <sup>H</sup>	41.0	31.0	3.0	...
E357.0 <sup>I</sup>		T61	45.0	36.0	3.0	100
		separately cast specimens	46.0	36.0	3.0	...
		castings, designated area <sup>H</sup>	41.0	31.0	3.0	...
		castings, no location designated <sup>H</sup>	45.0	36.0	3.0	...
F357.0 <sup>J</sup>		T6	45.0	36.0	3.0	...
359.0	A03590	T61	45.0	34.0	4.0	90
		separately cast specimens	45.0	34.0	4.0	...
		castings, designated area <sup>H</sup>	45.0	34.0	4.0	...

TABLE 2 Continued

Alloy		Temper <sup>B</sup>	Tensile Strength, min, ksi	Yield Strength <sup>C</sup> (0.2 % offset), min, ksi	Elongation in 2 in. or 4 x Diameter, min, %	Typical Brinell Hardness <sup>D</sup> 500-kgf load, 10-mm ball
ANSI <sup>E</sup>	UNS					
		castings, no location designated <sup>H</sup>	40.0	30.0	3.0	
		T62				
		separately cast specimens	47.0	38.0	3.0	100
		castings, designated area <sup>H</sup>	47.0	38.0	3.0	
		castings, no location designated <sup>H</sup>	40.0	30.0	3.0	
443.0	A04430	F	21.0	7.0	2.0	45
B443.0	A24430	F	21.0	6.0	2.5	45
A444.0	A14440	T4				
		separately cast specimens	20.0	...	20	...
		castings, designated area <sup>H</sup>	20.0	...	20	...
513.0 <sup>G</sup>	A05130	F	22.0	12.0	2.5	60
535.0	A05350	F	35.0	18.0	8.0	...
705.0	A07050	T1 or T5	37.0	17.0	10.0	...
707.0	A07070	T1	42.0	25.0	4.0	...
		T7	45.0	35.0	3.0	...
711.0 <sup>G</sup>	A07110	T1	28.0	18.0	7.0	70
713.0	A07130	T1 or T5	32.0	22.0	4.0	...
850.0	A08500	T5	18.0	...	8.0	...
851.0 <sup>G</sup>	A08510	T5	17.0	...	3.0	...
		T6	18.0	...	8.0	...
852.0 <sup>G</sup>	A08520	T5	27.0	...	3.0	...

<sup>A</sup> If agreed upon by manufacturer and the purchaser, other mechanical properties may be obtained by other heat treatments such as annealing, aging, or stress relieving.  
<sup>B</sup> Refer to ANSI H 35.1/H35.1(M) for description of tempers.  
<sup>C</sup> Yield strength to be evaluated only when specified in contract or purchase order.  
<sup>D</sup> Hardness values given for information only, not required for acceptance.  
<sup>E</sup> ASTM alloy designations are recorded in Practice B275.  
<sup>F</sup> Not required.  
<sup>G</sup> 332.0 formerly F332.0, 336.0 formerly A332.0, 513.0 formerly A514.0, 711.0 formerly C712.0, 851.0 formerly A850.0, 852.0 formerly B850.0.  
<sup>H</sup> These properties apply only to castings having section thicknesses not greater than 2 in. except that section thicknesses of 3/4 in., max, shall apply to Alloy A444.0.  
<sup>I</sup> Properties copied from A357.0–T61.  
<sup>J</sup> Properties copied from 357.0–T6.

TABLE 3 Tensile Requirements (SI Units) – [Metric]<sup>A,B</sup>

NOTE 1—For purposes of determining conformance with this specification, each value for tensile strength and yield strength shall be rounded to the nearest 1 MPa and each value for elongation shall be rounded to the nearest 0.5 %, both in accordance with the rounding method of Practice E29.

Alloy		Temper <sup>C</sup>	Tensile Strength, min, MPa <sup>D</sup>	Yield Strength <sup>E</sup> (0.2 % offset), min, MPa <sup>D</sup>	Elongation in 5D, min, %	Typical Brinell Hardness <sup>F</sup> 500-kgf load, 10-mm ball
ANSI <sup>G</sup>	UNS					
204.0	A02040	T4 separately cast specimens	330	200	7.0	...
242.0	A02420	T571	235	...	H	105
		T61	275	...	H	110
296.0	A02960	T4	230	105	4.5	75
		T6	240	...	2.0	90
		T7	230	110	3.0	...
308.0	A03080	F	165	...	...	70
319.0	A03190	F	185	95	2.5	95
332.0 <sup>I</sup>	A03320	T5	215	...	H	105
333.0	A03330	F	195	...	H	90
		T5	205	...	H	100
		T6	240	...	H	105
		T7	215	...	H	90
336.0 <sup>I</sup>	A03360	T551	215	...	H	105
		T65	275	...	H	125
354.0	A03540	T61				
		separately cast specimens	330	255	3.0	...
		casting, designated area <sup>J</sup>	325	250	3.0	...
		castings, no location designated <sup>J</sup>	295	230	2.0	...
		T62				
		separately cast specimens	360	290	2.0	...
		castings, designated area <sup>J</sup>	345	290	2.0	...
		castings, no location designated <sup>J</sup>	295	230	2.0	...
355.0	A03550	T51	185	...	H	75
		T62	290	...	H	105
		T7	250	...	H	90
		T71	235	185	H	80
C355.0	A33550	T61				
		separately cast specimens	275	205	3.0	85–90
		castings, designated area <sup>J</sup>	275	205	3.0	...
		castings, no location designated <sup>J</sup>	255	205	1.0	85

TABLE 3 Continued

Alloy		Temper <sup>C</sup>	Tensile Strength, min, MPa <sup>D</sup>	Yield Strength <sup>E</sup> (0.2 % offset), min, MPa <sup>D</sup>	Elongation in 5D, min, %	Typical Brinell Hardness <sup>F</sup> 500-kgf load, 10-mm ball		
ANSI <sup>G</sup>	UNS							
356.0	A03560	F	145	70	3.0			
		T6	230	150	3.0	85		
		T71	170	...	3.0	70		
A356.0	A13560	T61						
		separately cast specimens	260	180	4.0	80–90		
		castings, designated area <sup>J</sup>	230	180	4.0			
		castings, no location designated <sup>J</sup>	195	180	3.0			
357.0	A13570	T6	310	...	3.0	...		
A357.0		T61						
		separately cast specimens	310	250	3.0	100		
		castings, designated area <sup>J</sup>	315	250	3.0			
		castings, no location designated <sup>J</sup>	285	215	3.0			
E357.0 <sup>K</sup>	T61							
		separately cast specimens	310	250	3.0	100		
		castings, designated area <sup>J</sup>	315	250	3.0			
		castings, no location designated <sup>J</sup>	285	215	3.0			
F357.0 <sup>L</sup>	A03590	T6	310	...	3.0			
359.0		T61						
		separately cast specimens	310	235	4.0	90		
		castings, designated area <sup>J</sup>	310	235	4.0			
		castings, no location designated <sup>J</sup>	275	205	3.0			
			T62					
				separately cast specimens	325	260	3.0	100
				castings, designated area <sup>J</sup>	325	260	3.0	
				castings, no location designated <sup>J</sup>	275	205	3.0	
		443.0	A04430	F	145	50	2.0	45
B443.0	A24430	F	145	40	2.5	45		
A444.0	A14440	T4						
		separately cast specimens	140	...	18.0	...		
		castings, designated area <sup>J</sup>	140	...	18.0	...		
513.0 <sup>I</sup>	A05130	F	150	80	2.5	60		
535.0	A05350	F	240	125	7.0	...		
705.0	A07050	T1 or T5	255	115	9.0	...		
707.0	A07070	T1	290	170	4.0			
		T7	310	240	3.0			
		T1	195	125	6.0	70		
711.0 <sup>I</sup>	A07110	T1	195	125	6.0	70		
713.0	A07130	T1 or T5	220	150	4.0			
850.0	A08500	T5	125	...	7.0			
851.0 <sup>I</sup>	A08510	T5	115	...	3.0			
		T6	125	...	7.0			
		T5	185	...	3.0			
852.0 <sup>I</sup>	A08520	T5	185	...	3.0			

<sup>A</sup> If agreed upon by manufacturer and the purchaser, other mechanical properties may be obtained by other heat treatments such as annealing, aging, or stress relieving.  
<sup>B</sup> Guidelines for metric conversion from the "Tempers for Aluminum and Aluminum Alloys, Metric Edition" (Tan Sheets) Appendix A, were used to convert the tensile and yield values to SI units.  
<sup>C</sup> Refer to ANSI H 35.1/H35.1(M) for description of tempers.  
<sup>D</sup> For explanation of the SI Unit "MPa" see Appendix X2.  
<sup>E</sup> Yield strength to be evaluated only when specified in contract or purchase order.  
<sup>F</sup> Hardness values given for information only, not required for acceptance.  
<sup>G</sup> ASTM alloy designations are recorded in Practice B275.  
<sup>H</sup> Not required.  
<sup>I</sup> 332.0 formerly F332.0, 336.0 formerly A332.0, 513.0 formerly A514.0, 711.0 formerly C712.0, 851.0 formerly A850.0, 852.0 formerly B850.0.  
<sup>J</sup> These properties apply only to castings having section thicknesses not greater than 2 in. except that section thicknesses of 19-mm max, shall apply to Alloy A444.0.  
<sup>K</sup> Properties copied from A357.0–T61.  
<sup>L</sup> Properties copied from 357.0–T6.

4.1.4 Applicable drawing or part number,  
 4.1.5 The quantity in either pieces or pounds [kilograms],  
 4.2 Additionally, orders for material to this specification shall include the following information when required by the purchaser.  
 4.2.1 Whether foundry control is required (see Section 9),  
 4.2.2 Whether yield strength tests are required (see 10.1 and Table 2, Footnote C, [Table 4], [, Footnote D]),  
 4.2.3 Whether castings or test bars, or both, are to be artificially aged for Alloys 705.0-T5, 707.0-T5, and 713.0-T5 (see 10.3),

4.2.4 Whether test specimens cut from castings are required in addition to or instead of separately cast specimens (see Sections 10, 12.2, 13.2, and 15),  
 4.2.5 Whether heat treatment is to be performed in accordance with AMS 2771 (see Section 16),  
 4.2.6 Whether repairs are permissible (see Section 17),  
 4.2.7 Whether inspection is required at the producer's works (see Section 18),  
 4.2.8 DELETED  
 4.2.9 Whether surface requirements will be checked visually or by observational standards where such standards are established (see 19.1),

**TABLE 4 Discontinuity—Level Requirements for Aluminum Castings in Accordance with Film Reference Radiographs E155 or Digital Reference Radiographs E2422**

Discontinuity	Grade A <sup>A</sup>		Grade B		Grade C		Grade D	
	Section Thickness, in. (mm)							
	1/4 to 3/4 (6.4 to 19.0)	1/4 (6.4)	3/4 (19.0)	1/4 (6.4)	3/4 (19.0)	1/4 (6.4)	3/4 (19.0)	
Gas holes	none	1	1	2	2	5	5	
Gas porosity (round)	none	1	1	3	3	7	7	
Gas porosity (elongated)	none	1	1	3	4	5	5	
Shrinkage cavity	none	1	<sup>B</sup>	2	<sup>B</sup>	3		
Shrinkage porosity or sponge	none	1	1	2	2	4	3	
Foreign material (less dense material)	none	1	1	2	2	4	4	
Foreign material (more dense material)	none	1	1	2	1	4	3	
Segregation	none		none		none		none	
Cracks	none		none		none		none	
Cold shuts	none		none		none		none	
Surface irregularity				not to exceed drawing tolerance				
Core shaft				not to exceed drawing tolerance				

<sup>A</sup> Caution should be exercised in requesting grade A because of the difficulty in obtaining this level.

<sup>B</sup> No radiographs available. Use 1/4-in. [6-mm] for all thicknesses.

4.2.10 Whether liquid penetrant inspection is required (see 19.2),

4.2.11 Whether radiographic inspection is required and, if so, the radiographic grade of casting required (19.3, Table 4), and

4.2.12 Whether Practices B660 applies and, if so, the levels of preservation, packaging and packing required (see 23.4).

## 5. Responsibility for Quality Assurance

5.1 Unless otherwise specified in the contract or purchase order, the producer shall be responsible for the performance of all inspections and test requirements specified herein. Unless otherwise agreed upon, the producer may use his own or any other suitable facilities for the performance of the inspection and test requirements specified herein. The purchaser shall have the right to perform any of the inspections and tests set forth in the specification where such inspections are deemed necessary to confirm that the material conforms to prescribed requirements.

## 6. Manufacture

6.1 The responsibility of furnishing castings that can be laid out and machined to the finished dimensions within the permissible variations specified, as shown on the blueprints or drawings, shall rest with the producer, except where mold equipment is furnished by the purchaser.

## 7. Chemical Composition

7.1 The product shall conform to the chemical composition limits prescribed in Table 1. Conformance shall be determined by the producer by taking samples at the time castings are poured in accordance with E716 and analyzed in accordance with E607, E1251, E34, or CEN EN 14242. If the producer has determined the composition of the material during casting, they shall not be required to sample and analyze the finished product.

7.2 If it becomes necessary to analyze castings for conformance to chemical composition limits, the method used to sample castings for the determination of chemical composition

shall be by agreement between the producer and the purchaser. Analysis shall be performed in accordance with E716, E607, E1251, E34, or CEN EN 14242 (ICP method).

7.3 Other methods of analysis or in the case of a dispute the method of analysis shall be agreed upon by the producer and the purchaser.

7.4 A sample for determination of chemical composition shall be taken to represent one of the following:

7.4.1 Not more than 4000 lb [2000 kg] of clean castings or a single casting poured from one furnace. The maximum elapsed time between determinations shall be established for each alloy, but in any case the maximum elapsed time shall not exceed 8 hours.

## 8. Material Requirements—Castings Produced for Governmental and Military Agencies

8.1 Unless otherwise specified, only aluminum alloy conforming to the requirements of Specification B179 or producers foundry scrap, identified as being made from alloy conforming to Specification B179, shall be used in the remelting furnace from which molten metal is taken for pouring directly into castings. Additions of small amounts of modifying and grain refining elements or alloys are permitted.

8.2 Pure materials, recycled materials, and master alloys may be used to make alloys conforming to this specification, provided chemical analysis can be taken and adjusted to conform to Table 1 prior to pouring any castings.

## 9. Foundry Control—Castings Produced for Governmental or Military Agencies, or Both

9.1 When specified, castings shall be produced under foundry control approved by the purchaser. Foundry control shall consist of examination of castings by radiographic or other approved methods for determining internal discontinuities until the gating, pouring, and other foundry practices have been established to produce castings meeting the quality standards furnished by the purchaser or agreed upon between the purchaser and the producer. When foundry practices have

been so established, the production method shall not be significantly changed without demonstrating to the satisfaction of the purchaser that the change does not adversely affect the quality of the castings. Minor changes in pouring temperature of  $\pm 50^\circ\text{F}$  [ $\pm 28^\circ\text{C}$ ] from the established nominal temperature are permissible.

## 10. Tensile Requirements

10.1 The separately cast tension test specimens representing the castings shall meet the mechanical properties prescribed in Table 2 [Table 3].

10.2 When specified, the tensile strength and elongation of test specimens cut from castings shall be in accordance with Table 2 [Table 3] for Alloys 354.0, C355.0, A356.0, A357.0, E357.0, 359.0, and A444.0. For other alloys a minimum of 75 % of the tensile and yield strength values and not less than 25 % of the elongation values specified in Table 2 [Table 3] are required. The measurement of elongation is not required for test specimens cut from castings if 25% of the specified minimum elongation value published in Table 2 [Table 3] is 0.5 % or less. If grade D quality castings as described in Table 4 are specified, no tensile tests shall be specified nor tensile requirements be met on specimens cut from castings.

10.3 Although Alloys 705.0, 707.0, and 713.0 are most frequently used in the naturally aged condition, by agreement of the producer and the purchaser, the castings may be artificially aged. The producer and the purchaser may also agree to base the acceptance of castings on artificially aged test bars. The conditions of artificial aging shown in Practice B917/B917M or AMS 2771 shall be employed unless other conditions are accepted by mutual consent.

## 11. Workmanship, Finish, and Appearance

11.1 The finished castings shall be uniform in composition and free of blowholes, cracks, shrinks, and other discontinuities in accordance with standards designated and agreed upon as acceptable by the purchaser.

## 12. Test Specimens

12.1 Separately cast test specimens shall be cast in iron molds. A recommended gating method is shown in Fig. 1 [Fig. 2]. The test section of the tension test specimen shall be cast to size in accordance with the dimensions shown in Fig. 1 [Fig. 2] and not machined prior to test. Grip ends may be machined to adapt them in such a manner as to ensure axial loading.

12.2 When properties of castings are to be determined, tension test specimens shall be cut from the locations designated on the drawings, unless otherwise negotiated. If no locations are designated, one or more specimens shall be taken to include locations having significant variation in casting thickness, except that specimens shall not be taken from areas directly under risers. The tension test specimens shall be the standard 0.500-in. [12.5-mm] diameter specimens shown in Fig. 9 of Test Methods B557 [B557M] or a round specimen of smaller size proportional to the standard specimens. In no case shall the dimensions of the smallest specimen be less than the following:

	in.	mm
Diameter of reduced section.	0.250	[6.00]
Length of reduced section	1¼	[32]
Radius of fillet	¾/16	[5]
Diameter of end section	¾	[10]
Overall length:		
With shouldered ends	2¾	[60]
With threaded ends	3	[75]
With plain cylindrical ends	4	[100]

12.3 When necessary, a rectangular specimen may be used proportional to that shown for the 0.500 in. [12.5-mm] wide specimen in Fig. 6 of Test Methods B557 [B557M], but in no case shall its dimensions be less than the following:

	in.	mm
Width of reduced section,	¼	[6]
Length of reduced section,	1¼	[32]
Radius of fillet,	¼	[6]
Overall length,	4	[100]

The specified elongation values shall not apply to tests of rectangular specimens.

12.4 If the castings are to be heat treated and separately cast specimens are to be used, the specimens representing such castings shall be heat treated with the castings they represent. If castings are to be heat treated and tests are to be obtained on the castings, the test specimens shall be taken from the castings after heat treatment.

## 13. Number of Tests

13.1 Unless otherwise agreed upon by the purchaser and producer, two tension test specimens shall be separately cast and tested to represent the following:

13.1.1 Not more than 4000 lb [2000 kg] of clean castings (gates and risers removed) or a single casting poured from one furnace.

13.1.2 The castings poured continuously from one furnace in not more than eight consecutive hours.

13.2 When tensile properties of castings are to be determined, one per melt-heat combination shall be tested unless otherwise shown on the drawing or specified in the purchase order.

13.3 If any test specimen shows defective machining or flaws, it may be discarded, in which case the purchaser and the producer shall agree upon the selection of a replacement specimen.

## 14. Test Methods

14.1 The tensile properties shall be determined in accordance with Test Methods B557 [B557M].

## 15. Retests

15.1 If the results of the tension test do not conform to the requirements prescribed in Table 2 [Table 4], test bars representative of the castings may be retested in accordance with the replacement tests and retest provisions of Test Methods B557 [B557M] and the results of retests shall conform to the requirements as to mechanical properties specified in Table 2 [Table 4].

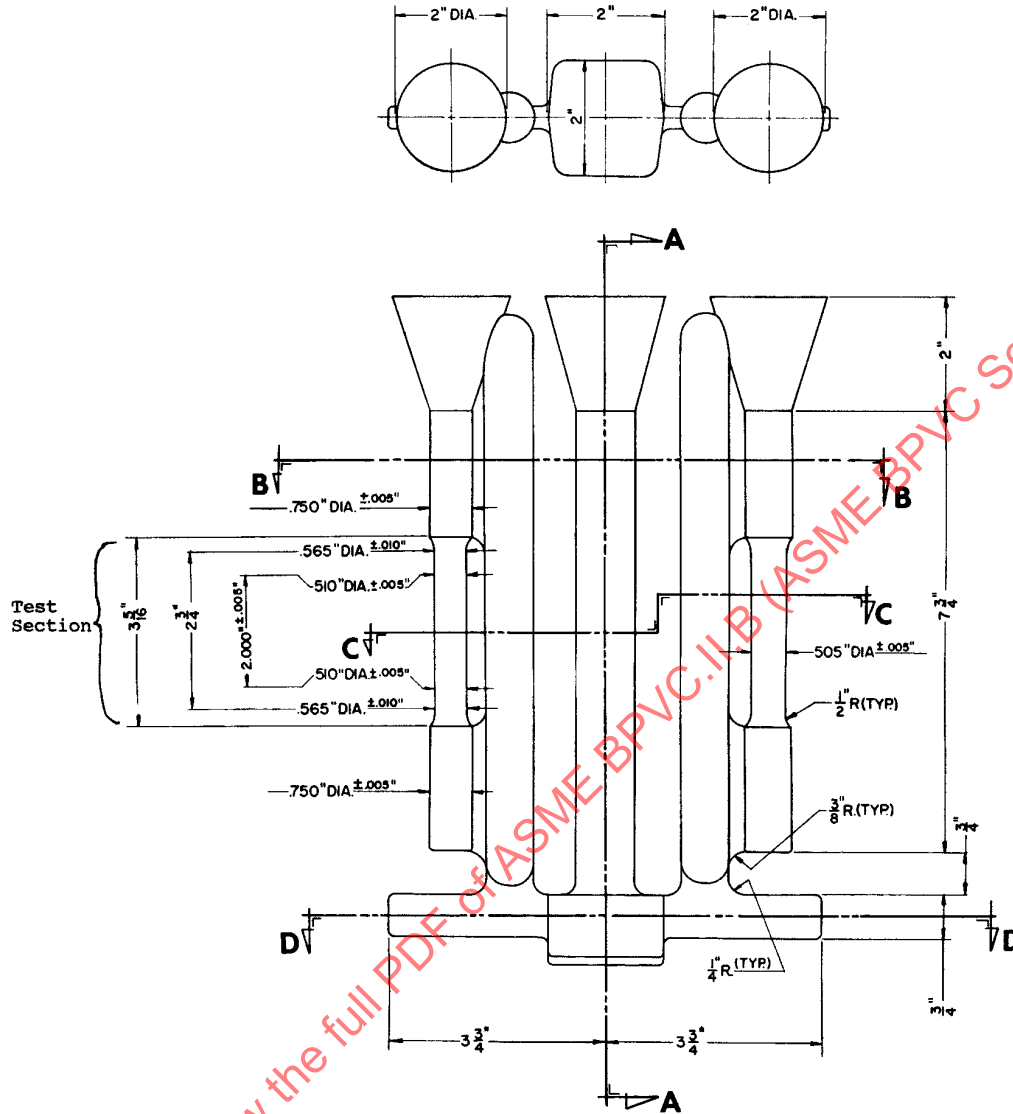

Nominal draft angle to be 20° on all square or rectangular sections in direction transverse to parting line.

NOTE 1—Test section of test bar: this section to be gradually tapered from the ends towards the center.

FIG. 1 Tension Test Specimen Casting – (Inch Pounds)

**16. Heat Treatment**

16.1 Heat treatment of castings shall be performed in accordance with Practice B917/B917M.

16.2 When specified, heat treatment shall be in accordance with AMS 2771.

**17. Repair of Castings**

17.1 Castings may be repaired only by processes approved and agreed upon by the producer and purchaser, such as,

welding, impregnation, peening, blending, soldering, and so forth. Limitations on the extent and frequency of such repairs, and methods of inspection of repaired areas should also be agreed upon.

17.1.1 The welding procedure and welders shall be qualified in accordance with Section IX of the ASME BPVC.

17.2 *Repairing of Castings Produced for Governmental and Military Agencies:*

17.2.1 *Welding:*

17.2.1.1 When welding is permitted, it shall be done by methods suitable for the particular alloy. Welding methods

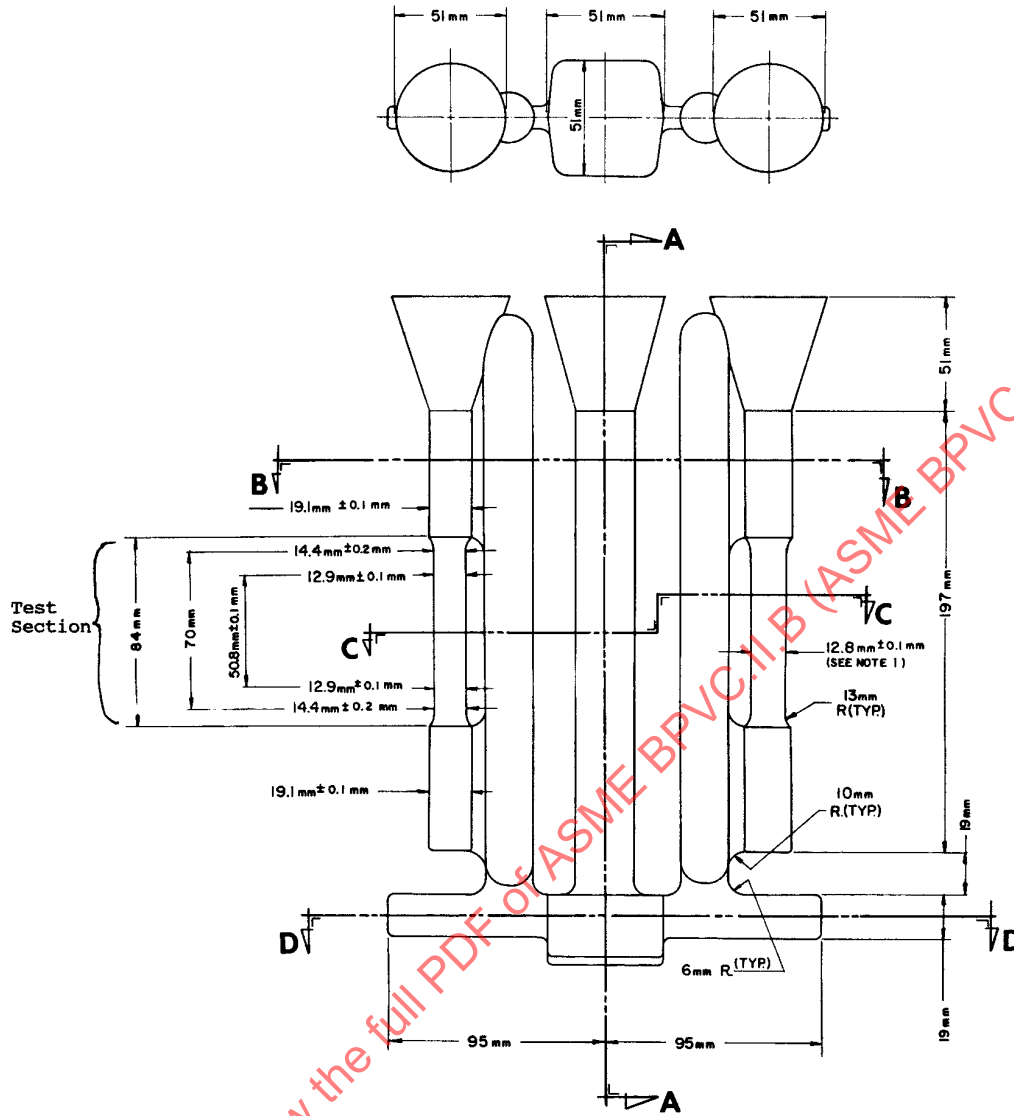

Nominal draft angle to be 20° on all square or rectangular sections in direction transverse to parting line.

NOTE 1—Test section of test bar: this section to be gradually tapered from the ends towards the center.

FIG. 2 Tension Test Specimen Casting – [Metric]

shall be in accordance with such specifications as are referenced on the applicable drawings, or as are required by the contract or order.

17.2.1.2 All welding shall be done by qualified welders and by methods approved by the purchaser.

17.2.1.3 When castings are to be supplied in the heat treated condition, they shall be heat treated to the required temper after welding, except that small arc welds may be performed without subsequent heat treatment upon approval of the purchaser.

17.2.1.4 Unless otherwise specified, castings that have been repaired by welding shall have the welded areas examined radiographically after all reworking and heat treatment have been completed.

17.2.1.5 All welds shall be free from cracks, lack of fusion, and meet the same quality requirements as the parent material.

17.2.1.6 Welded castings shall be marked with a symbol of three concentric circles with a letter or number designating the welder adjacent to the symbol. The outer circle of the symbol shall be no larger than ¼ in. (6 mm) in outside diameter. All welded areas shall be encircled with a ring or white paint prior to submission for final inspection.

17.2.1.7 Repair welding of castings used in naval shipboard pressure vessels, piping systems, and machinery shall be performed in accordance with requirements for repair of castings specified in NAVSEA Technical Publication S9074-AR-GIB-010/278.

17.3 Impregnation—When impregnation is permitted, it shall be to correct general seepage leaks only and shall not be used to correct poor foundry technique or porosity in excess of

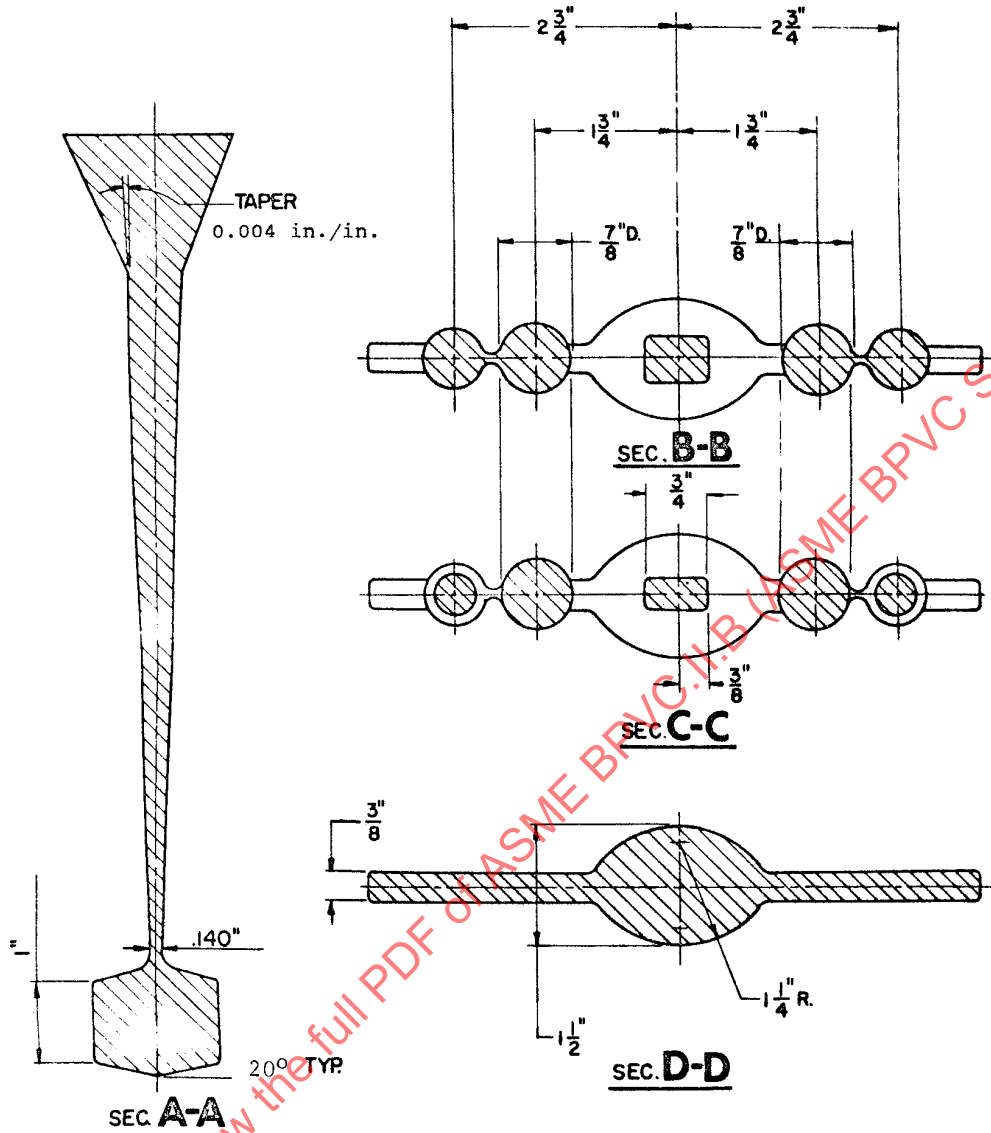

FIG. 8 Tension Test Specimen Casting (Cross Section) - (Inch Pounds)

accepted standards. It shall be accomplished in accordance with MIL-STD-276. Unless otherwise authorized by the purchaser, castings which have been impregnated shall be marked "IMP".

17.4 *Peening*—When peening is permitted, it shall be to correct localized minor seepage leaks and small surface imperfections only, or to disclose subsurface voids for the purpose of inspection. Peening will not be permitted to repair cracks, cold shuts, shrinks, misruns, defects due to careless handling, or other similar major defects. Peening may be accomplished either hot or cold and shall be performed by methods which are acceptable to the purchaser. Peened castings shall be marked with a Maltese cross approximately 1/4 in. [6-mm] high.

17.5 *Blending*—Blending with suitable grinders or other tools will be permitted for the removal of surface imperfections only, and shall not result in dimensions outside the tolerances shown on the applicable drawings.

**18. Source Inspection**

18.1 If the purchaser elects to make an inspection of the castings at the producer's works, it shall be so stated in the contract or order.

18.2 If the purchaser elects to have an inspection made at the producer's works, the producer shall afford the inspector all reasonable facilities to satisfy him that the material is being furnished in accordance with this specification. All tests and inspections shall be so conducted as not to interfere unnecessarily with the operation of the works.

**19. Foundry Inspection**

19.1 Requirements such as surface finish, parting line projections, snagging projections where gates and risers were removed, and so forth, may be checked visually. It is advisable to have agreed upon observational standards representing both acceptable and unacceptable material.

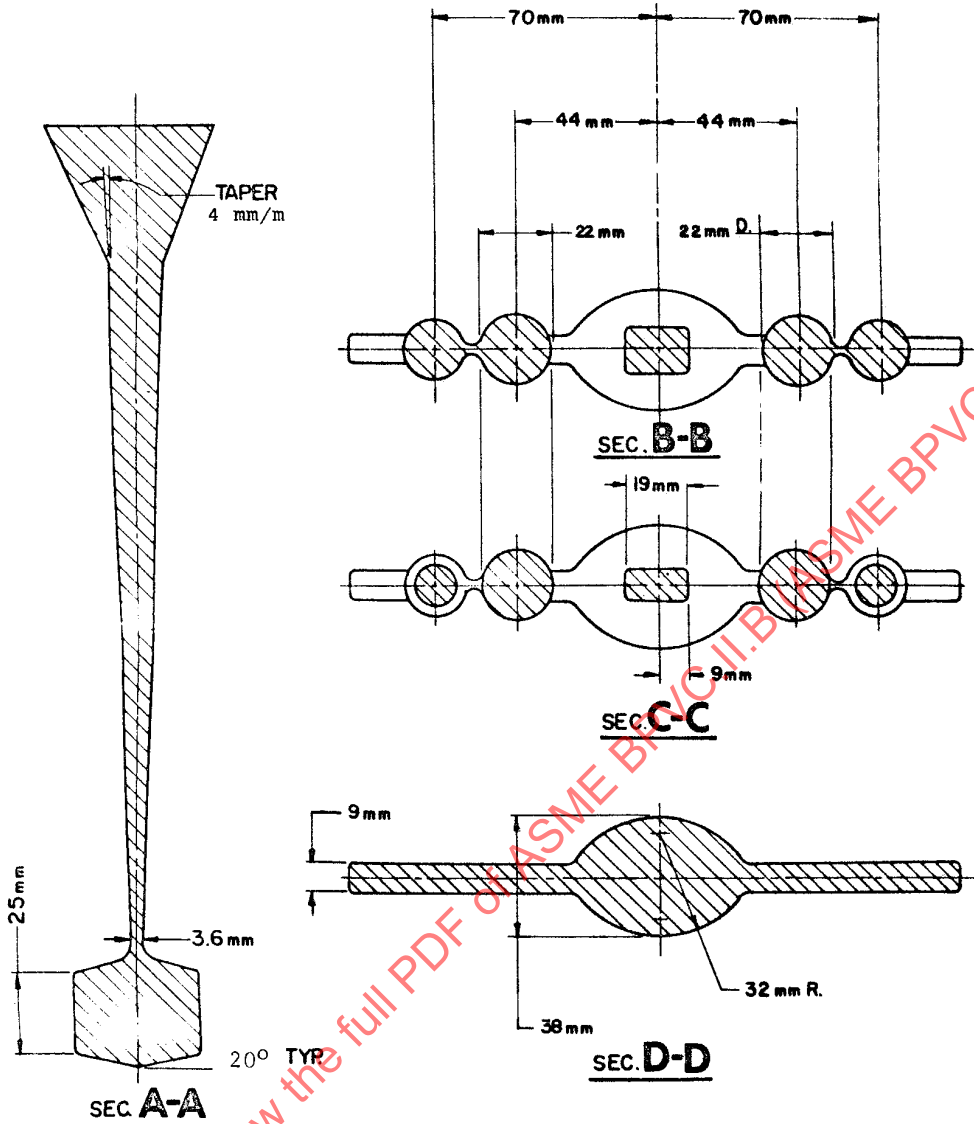

FIG. 4 Tension Test Specimen Casting Cross Section - [Metric]

19.2 Liquid Penetrant Inspection:

19.2.1 When specified, liquid penetrant inspection shall be in accordance with Test Method E165, and the required sensitivity shall be specified.

19.2.2 Acceptance standards for discontinuities shall be agreed upon, including size and frequency per unit area and location.

19.3 Radiographic Inspection:

19.3.1 Radiographic inspection shall be in accordance with Guide E94 and Film Reference Radiographs E155.

19.3.2 When agreed upon between the manufacturer and purchaser, digital radiographic inspection shall be in accordance with Guide E94 and Digital Reference Radiographs E2422.

19.3.3 Radiographic acceptance shall be in accordance with the requirements selected from Table 4. Any modifications of the table and the frequency per unit area and location of discontinuities should also be agreed upon.

19.3.4 The number, film size and orientation of radiographs, and the number of castings radiographically inspected shall be agreed upon by the producer and purchaser.

20. Identification and Repair Marking for Castings Produced for Government and Military Agencies

20.1 Identification—Unless otherwise specified, each casting shall be marked with the applicable drawing or part number. The marking shall consist of raised Arabic numbers, and when applicable upper-case letters, cast integral. The

location of the identification marking shall be as specified on the applicable drawing. When the location is not specified on the drawing, the drawing or part number, or both, shall be placed in a location mutually agreeable to the purchaser and producer.

20.2 *Lot Identification*—When practical, each casting shall also be marked with the melt or inspection lot number.

20.3 *Lot*—A lot shall consist of all of the cleaned castings poured from the same heat or melt when subsequent heat treatment is not required.

20.3.1 When the castings consist of alloys that require heat treatment, the lot shall consist of all castings from the same melt or heat that have been heat treated in the same furnace charge, or if heat treated in a continuous furnace, all castings from the same melt or heat that are discharged from the furnace during a 4-hour period.

20.4 *Repair Marking*—All identification markings indicating repairs as specified in 19.1, 19.2, and 19.3 shall be made with a waterproof marking fluid.

## 21. Rejection and Rehearing

21.1 Material that fails to conform to the requirements of this specification may be rejected. Rejection should be reported to the producer promptly and in writing. In case of dissatisfaction with the results of the test, the producer may make claim for a rehearing.

## 22. Certification

22.1 The producer shall furnish to the purchaser a certificate stating that each lot has been sampled, tested, and

inspected in accordance with this specification, and has met the requirements. In addition, all test reports required by this specification shall be supplied with the certification.

## 23. Packaging, Marking, and Shipping

23.1 The material shall be packaged in such a manner as to prevent damage in ordinary handling and transportation. The type of packaging and gross weight of individual containers shall be left to the discretion of the producer unless otherwise agreed upon. Packaging methods and containers shall be so selected as to permit maximum utility of mechanical equipment in unloading and subsequent handling. Each package or container shall contain only one part number, alloy, and temper of material when packaged for shipment unless otherwise agreed upon.

23.2 Each package or container shall be marked with the purchase order number, part number, quantity, specification number, alloy and temper, gross and net weights, and the name of the producer.

23.3 Packages or containers shall be such as to ensure acceptance by common or other carriers for safe transportation at the lowest rate to the point of delivery.

23.4 When specified in the contract or purchase order, material shall be preserved, packaged, and packed in accordance with the requirement of Practices B660. The applicable levels shall be as specified in the contract or order. Marking for shipment of such material shall be in accordance with Fed. Std. No. 123 or Practice D3951 for civil agencies and MIL-STD-129 for military agencies.

## 24. Keywords

24.1 aluminum; permanent mold castings

## ANNEXES

### (Mandatory Information)

#### A1. BASIS FOR INCLUSION OF PROPERTY LIMITS

A1.1 Limits are established at a level at which a statistical evaluation of the data indicates that 99 % of the population obtained from all standard material meets the limit with 95 % confidence. For the products described, mechanical property limits for the respective size ranges are based on the analyses of at least 100 data from standard production material with no

more than ten data from a given lot. All tests are performed in accordance with the appropriate ASTM test methods. For informational purposes, refer to “Statistical Aspects of Mechanical Property Assurance” in the Related Material section of the *Annual Book of ASTM Standards*, Vol 02.02.

**A2. ACCEPTANCE CRITERIA FOR INCLUSION OF NEW ALUMINUM AND ALUMINUM ALLOYS IN THIS SPECIFICATION**

A2.1 Prior to acceptance for inclusion in this specification, the composition of wrought or cast aluminum or aluminum alloy shall be registered in accordance with ANSI H35.1/H35.1(M). The Aluminum Association holds the Secretariat of ANSI H35 Committee and administers the criteria and procedures for registration.

A2.2 If it is documented that the Aluminum Association could not or would not register a given composition, an alternative procedure and the criteria for acceptance shall be as follows:

A2.2.1 The designation submitted for inclusion does not utilize the same designation system as described in ANSI H35.1/H35.1(M). A designation not in conflict with other designation systems or a trade name is acceptable.

A2.2.2 The aluminum or aluminum alloy has been offered for sale in commercial quantities within the prior twelve months to at least three identifiable users.

A2.2.3 The complete chemical composition limits are submitted.

A2.2.4 The composition is, in the judgement of the responsible subcommittee, significantly different from that of any other aluminum or aluminum alloy already in this specification.

A2.2.5 For codification purposes, an alloying element is any element intentionally added for any purpose other than grain refinement and for which minimum and maximum limits are specified. Unalloyed aluminum contains a minimum of 99.00 % aluminum.

A2.2.6 Standard limits for alloying elements and impurities are expressed to the following decimal places:

Less than 0.001 %	0.000X
0.001 to but less than 0.01 %	0.00X
0.01 to but less than 0.10 %	
Unalloyed aluminum made by a refining process	0.0XX
Alloys and unalloyed aluminum not made by a refining process	0.0X
0.10 through 0.55 %	0.XX
(It is customary to express limits of 0.30 through 0.55 % as 0.X0 or 0.X5)	
Over 0.55 %	0.X, X.X, etc.
(Except that combined Si + Fe limits for 99.00 % minimum aluminum must be expressed as 0.XX or 1.XX)	

A2.2.7 Standard limits for alloying elements and impurities are expressed in the following sequence: Silicon; Iron; Copper; Manganese; Magnesium; Chromium; Nickel; Zinc; Titanium; (Note A2.1); Other Elements, Each; Other Elements, Total; Aluminum (Note A2.2).

NOTE A2.1—Additional specified elements having limits are inserted in alphabetical order of their chemical symbols between Titanium and Other Elements, Each, or are specified in footnotes.

NOTE A2.2—Aluminum is specified as *minimum* for unalloyed aluminum and as a *remainder* for aluminum alloys.

**APPENDICES**

(Nonmandatory Information)

**X1. PROPERTIES AND CHARACTERISTICS**

X1.1 Data in Table X1.1 are approximate and are supplied for general information only.

TABLE X1.1 Properties and Characteristics – (Inch-Pound Units) – (SI Units) – [Metric]

NOTE 1—indicates best of group; 5 indicates poorest of group.

Alloy		Approximate Melting Range °F <sup>B</sup> [°C]	Foundry Characteristics						Other Characteristics							
ANSI <sup>A</sup>	UNS		Resistance to Hot Cracking <sup>C</sup>	Pressure Tightness	Fluidity <sup>D</sup>	Solidification Shrinkage Tendency <sup>E</sup>	Normally Heat-Treated	Resistance to Corrosion <sup>F</sup>	Machining <sup>G</sup>	Polishing <sup>H</sup>	Electroplating <sup>I</sup>	Anodizing (Appearance) <sup>J</sup>	Chemical Oxide Coating (Protection) <sup>K</sup>	Strength at Elevated Temp <sup>L</sup>	Suitability for Welding <sup>M</sup>	Suitable for Brazing <sup>N</sup>
204.0	A02040	985 to 1200 [529-649]	4	3	3	4	yes	4	1	2	1	3	4	1	4	no
242.0	A02420	990 to 1175 [532-635]	4	4	3	4	yes	4	2	2	1	2	3	1	4	no
296.0	A02960	970 to 1170 [521-632]	4	3	3	4	yes	4	1	2	1	3	4	1	4	no
308.0	A03080	970 to 1135 [521-613]	2	2	2	3	yes	4	3	3	2	4	3	3	2	no
319.0	A03190	950 to 1125 [510-607]	2	2	2	3	yes	3	3	3	2	4	3	3	2	no
336.0 <sup>O</sup>	A03360	1080 to 1050 [538-566]	1	2	1	3	yes	3	4	5	4	5	2	2	2	no
332.0 <sup>O</sup>	A03320	970 to 1080 [521-582]	1	2	1	2	aged only	3	3	4	3	5	3	3	2	no
333.0	A03330	960 to 1085 [516-585]	2	2	2	3	no	3	3	3	3	5	3	3	2	no
354.0	A03540	1015 to 1150 [546-621]	1	1	2	2	yes	3	3	3	2	4	2	2	2	no
355.0	A03550	1015 to 1150 [546-621]	1	1	2	2	yes	3	3	3	2	4	2	2	2	no
C355.0	A33550	1015 to 1150 [546-621]	1	1	2	2	yes	3	3	3	2	4	2	2	2	no
356.0	A03560	1035 to 1135 [557-613]	1	1	2	1	yes	2	3	3	1	4	2	3	2	no
A356.0	A13560	1035 to 1135 [557-613]	1	1	2	1	yes	2	3	3	1	4	2	3	2	no
357.0		1035 to 1135 [557-613]	1	1	2	1	yes	2	3	3	1	4	2	3	2	no
A357.0	A13570	1035 to 1135 [557-613]	1	1	2	1	yes	2	3	3	1	4	2	3	2	no
E357.0		1035 to 1135 [557-613]	1	1	2	1	yes	2	3	3	1	4	2	3	2	no
F357.0		1035 to 1135 [557-613]	1	1	2	1	yes	2	3	3	1	4	2	3	2	no
359.0	A03590	1035 to 1135 [557-613]	1	1	2	1	yes	2	3	3	1	4	2	3	2	no
443.0	A04430	1065 to 1170 [574-632]	1	1	1	2	no	3	5	4	2	4	2	4	1	ltd
B443.0	A24430	1065 to 1170 [574-632]	1	1	1	2	no	2	5	4	2	4	2	4	1	ltd
A444.0	A14440	1065 to 1145 [574-618]	1	1	1	1	yes	2	5	4	2	4	2	4	1	ltd
513.0 <sup>O</sup>	A05130	1075 to 1180 [579-638]	4	5	5	4	no	1	1	1	4	1	1	3	5	no
535.0	A05350	1020 to 1165 [549-629]	4	5	5	5	no	1	1	1	5	1	1	3	4	no
705.0	A07050	1105 to 1180 [596-638]	5	4	4	5	aged only	2	1	1	3	1	2	5	4	yes
707.0	A07070	1085 to 1165	5	4	4	5	yes	2	1	1	3	1	2	5	5	yes
711.0 <sup>O</sup>	A07110	[585-629] 1120 to 1190 [604-643]	5	4	4	5	aged only	2	1	1	2	1	2	5	4	yes

TABLE X1.1 Continued

Alloy		Approximate Melting Range °F <sup>B</sup> [°C]	Foundry Characteristics					Other Characteristics								
ANSI <sup>A</sup>	UNS		Resistance to Hot Cracking <sup>C</sup>	Pressure Tightness	Fluidity <sup>D</sup>	Solidification Shrinkage Tendency <sup>E</sup>	Normally Heat-Treated	Resistance to Corrosion <sup>F</sup>	Machining <sup>G</sup>	Polishing <sup>H</sup>	Electroplating <sup>I</sup>	Anodizing (Appearance) <sup>J</sup>	Chemical Oxide Coating (Protection) <sup>K</sup>	Strength at Elevated Temp <sup>L</sup>	Suitability for Welding <sup>M</sup>	Suitable for Brazing <sup>N</sup>
713.0	A07130	1100 to 1185 [593-641]	5	4	4	5	aged only	2	1	1	2	1	2	5	4	yes
850.0	A08500	435 to 1200 [224-649]	5	5	5	5	aged only	3	1	1	5	4	5	P	5	no
851.0 <sup>O</sup>	A08510	440 to 1165 [227-629]	4	4	5	4	yes	3	1	1	5	4	5	P	5	no
852.0 <sup>O</sup>	A08520	400 to 1175 [204-635]	5	5	5	5	aged	3	1	1	5	4	5	P	5	no

<sup>A</sup> ASTM alloy designations are recorded in Practice B275.

<sup>B</sup> Temperatures of solidus and liquidus are indicated, pouring temperatures will be higher.

<sup>C</sup> Ability of alloy to withstand stresses from contraction while cooling through hot-short or brittle temperature range.

<sup>D</sup> Ability of liquid alloy to flow readily in mold and fill thin sections.

<sup>E</sup> Decrease in volume accompanying freezing of alloy and measure of amount of compensating feed metal required in form of risers.

<sup>F</sup> Based on resistance of alloy in standard type salt-spray test.

<sup>G</sup> Composite rating based on ease of cutting, chip characteristics, quality of finish, and tool life. Ratings, in the case of heat-treatable alloys, based on T6 temper. Other tempers, particularly the annealed temper, may have lower rating.

<sup>H</sup> Composite rating based on ease and speed of polishing and quality of finish provided by typical polishing procedure.

<sup>I</sup> Ability of casting to take and hold an electroplate applied by present standard methods.

<sup>J</sup> Rates of lightness of color, brightness, and uniformity of clear anodized coating applied in sulfuric acid electrolyte.

<sup>K</sup> Rated on combined resistance of coating and base alloy to corrosion.

<sup>L</sup> Rating based on tensile and yield strengths at temperatures up to 500°F [260°C], after prolonged heating at testing temperature.

<sup>M</sup> Based on ability of material to be fusion-welded with filler rod or same alloy.

<sup>N</sup> Refers to suitability of alloy to withstanding brazing temperatures without excessive distortion or melting.

<sup>O</sup> 336.0 formerly A332.0, 332.0 formerly F332.0, 513.0 formerly A514.0, 711.0 formerly C712.0, 851.0 formerly A850.0, 852.0 formerly B850.0.

<sup>P</sup> Not recommended for service at elevated temperatures.

ASME NORMDOC.COM : Click to view the full PDF of ASME BPVC.II.B (ASME BPVC Section II part B) 2025

X2. METRIC EQUIVALENTS

X2.1 The SI unit for strength properties now shown is in accordance with the International System of Units (SI) (IEEE/ASTM SI 10). The derived SI unit for force is the newton (N), which is defined as that force which when applied to a body having a mass of one kilogram gives it an acceleration of one metre per second squared ( $N = \text{kg}\cdot\text{m}/\text{s}^2$ ). The derived SI unit

for pressure or stress is the newton per square metre ( $\text{N}/\text{m}^2$ ), which has been named the pascal (Pa) by the General Conference on Weights and Measures. Since  $1 \text{ ksi} = 6\,894\,757 \text{ Pa}$ , the metric equivalents are expressed as megapascal (MPa), which is the same as  $\text{MN}/\text{m}^2$  and  $\text{N}/\text{mm}^2$ .

X3. INACTIVE ALLOYS

X3.1 Alloys listed as inactive by the Aluminum Association—208.0 and 222.0. Listing the composition limits, mechanical properties, and characteristics of the alloys is a

method of preserving this data should it be needed at some future date.

TABLE X3.1 Chemical Composition Limits

NOTE 1—All applicable notes and footnotes can be found in Table 1

Alloy		Aluminum	Composition, %										Other Elements	
ANSI	UNS		Silicon	Iron	Copper	Manganese	Magnesium	Chromium	Nickel	Zinc	Titanium	Tin	Each	Total
208.0	A02080	remainder	2.5–3.5	1.2	3.5–4.5	0.50	0.10	...	0.35	1.0	0.25	...	...	0.50
222.0	A02220	remainder	2.0	1.5	9.2–10.7	0.50	0.15–0.35	...	0.50	0.8	0.25	...	...	0.35

<sup>A</sup>Beryllium 0.002 max

TABLE X3.2 Tensile Requirements (Inch-Pound Units)—Inactive Alloys

NOTE 1—All applicable notes and footnotes can be found in Table 2.

Alloy		Temper	Tensile Strength, min, ksi	Yield Strength (0.2 % offset), min, ksi (MPa)	Elongation in 2 in. or 4 x diameter, min, %	Typical Brinell Hardness, 500 kgf, 10 mm
ANSI	UNS					
208.0	A02080	T4	33.0	15.0	4.5	75
		T6	35.0	22.0	2.0	90
		T7	33.0	16.0	3.0	80
222.0	A02220	T551	30.0	...	<sup>A</sup>	115
		T65	40.0	...	<sup>A</sup>	140

<sup>A</sup> Not required.

TABLE X3.3 Tensile Requirements (SI Units)—[Metric]—Inactive Alloys

NOTE 1—All applicable notes and footnotes can be found in Table 3.

Alloy		Temper	Tensile Strength, min, MPa	Yield Strength (0.2 % offset), min, MPa	Elongation in 5D, min, %	Typical Brinell Hardness, 500 kgf, 10 mm
ANSI	UNS					
208.0	A02080	T4	230	105	4.5	75
		T6	240	150	2.0	90
		T7	230	110	3.0	80
222.0	A02220	T551	205	...	<sup>A</sup>	115
		T65	275	...	<sup>A</sup>	140

<sup>A</sup> Not required.

**TABLE X3.4 Properties and Characteristics—(Inch-Pound Units) – (SI Units) –[Metric]—Inactive Alloys**

NOTE 1—1 indicates best of group, 5 indicates poorest of group.

NOTE 2—All applicable notes and footnotes can be found in Table X1.1.

Alloy		Pattern Shrinkage Allowance, <sup>A</sup> in./ft [mm/m]	Approximate Melting Range, °F [°C]	Resistance to Hot Cracking <sup>E</sup>	Pressure Tightness	Fluidity <sup>B</sup>	Solidification Shrinkage Tendency	Normally Heat Treated	Resistance to Corrosion <sup>C</sup>	Machining <sup>D</sup>	Polishing <sup>F</sup>	Electroplating <sup>G</sup>	Anodizing (Appearance) <sup>H</sup>	Chemical Oxide Coating (Protection) <sup>A</sup>	Strength at Elevated Temperature <sup>B</sup>	Suitability for Welding <sup>C</sup>	Suitability for Brazing <sup>D</sup>
ANSI <sup>F</sup>	UNS																
208.0	A02080	5/32 [13]	970-1160 [521-627]	2	2	2	2	yes	4	3	3	2	3	3	3	2	no
222.0	A02220	5/32 [13]	965-1155 [518-624]	3	3	3	3	yes	4	1	2	1	3	4	1	4	no

ASMENORMDOC.COM : Click to view the full PDF of ASME BPVC.II.B (ASME BPVC Section II part B) 2025

# SPECIFICATION FOR COPPER AND COPPER-ALLOY SEAMLESS CONDENSER TUBES AND FERRULE STOCK



**SB-111/SB-111M**

(Identical with ASTM Specification B111/B111M-18a except that certification and test reports have been made mandatory.)

ASME NORMDOC.COM : Click to view the full PDF of ASME BPVC.II.B (ASME BPVC Section II part B) 2025

# Specification for Copper and Copper-Alloy Seamless Condenser Tubes and Ferrule Stock

## 1. Scope

1.1 This specification establishes the requirements for seamless tube and ferrule stock of copper and various copper alloys up to 3 1/8 in. [80 mm] inclusive, in diameter, for use in surface condensers, evaporators, and heat exchangers. The following coppers and copper alloys are specified:

Copper or Copper Alloy UNS No.	Previously Used Designation	Description
C10100	OFE	Oxygen-free electronic
C10200	OF <sup>A</sup>	Oxygen-free without residual deoxidants
C10300	...	Oxygen-free, extra low phosphorus
C10800	...	Oxygen-free, low phosphorus
C12000	DLP <sup>A</sup>	Phosphorized, low residual phosphorus
C12200	DHP <sup>A</sup>	Phosphorized, high residual phosphorus
C14200	DPA <sup>A</sup>	Phosphorized, arsenical
C15630	...	Nickel Phosphorus
C19200	...	Phosphorized, 1 % iron
C23000	...	Red Brass
C28000	...	Muntz Metal
C44300	...	Admiralty Metals, B, C, and D
C44400	...	...
C44500	...	...
C60800	...	Aluminum Bronze
C61300	...	...
C61400	...	Aluminum Bronze, D
C68700	...	Aluminum Brass, B
C70400	...	95-5 Copper-Nickel
C70600	...	90-10 Copper-Nickel
C70620	...	90-10 Copper-Nickel—Welding Grade
C71000	...	80-20 Copper-Nickel
C71500	...	70-30 Copper-Nickel
C71520	...	70-30 Copper-Nickel—Welding Grade

Copper or Copper Alloy UNS No.	Previously Used Designation	Description
C71640	...	Copper-nickel-iron-manganese
C72200	...	...

<sup>A</sup> Designations listed in Classification B224.

1.2 *Units*—The values stated in either SI units or inch-pound units are to be regarded separately as standard. The values stated in each system may not be exact equivalents; therefore, each system shall be used independently of the other. Combining values from the two systems may result in non-conformance with the standard.

1.3 The following safety hazards caveat pertains only to the test methods portion, Section 19, of this specification: *This standard does not purport to address all of the safety concerns, if any, associated with its use. It is the responsibility of the user of this standard to establish appropriate safety, health, and environmental practices and determine the applicability of regulatory limitations prior to use. (Warning—Mercury has been designated by many regulatory agencies as a hazardous substance that can cause serious medical issues. Mercury, or its vapor, has been demonstrated to be hazardous to health and corrosive to materials. Use caution when handling mercury and mercury-containing products. See the applicable product Safety Data Sheet (SDS) for additional information. The potential exists that selling mercury or mercury-containing products, or both, is prohibited by local or national law. Users must determine legality of sales in their location.)*

1.4 *This international standard was developed in accordance with internationally recognized principles on standardization established in the Decision on Principles for the Development of International Standards, Guides and Recommendations issued by the World Trade Organization Technical Barriers to Trade (TBT) Committee.*

## 2. Referenced Documents

2.1 The following documents in the current issue of the *Annual Book of ASTM Standards* form a part of this specification to the extent referenced herein:

## 2.2 ASTM Standards:

B153 Test Method for Expansion (Pin Test) of Copper and Copper-Alloy Pipe and Tubing  
 B154 Test Method for Mercurous Nitrate Test for Copper Alloys  
 B170 Specification for Oxygen-Free Electrolytic Copper—Refinery Shapes  
 B224 Classification of Coppers  
 B846 Terminology for Copper and Copper Alloys  
 B858 Test Method for Ammonia Vapor Test for Determining Susceptibility to Stress Corrosion Cracking in Copper Alloys  
 B968/B968M Test Method for Flattening of Copper and Copper-Alloy Pipe and Tube  
 E8/E8M Test Methods for Tension Testing of Metallic Materials  
 E29 Practice for Using Significant Digits in Test Data to Determine Conformance with Specifications  
 E53 Test Method for Determination of Copper in Unalloyed Copper by Gravimetry  
 E54 Test Methods for Chemical Analysis of Special Brasses and Bronzes (Withdrawn 2002)  
 E62 Test Methods for Chemical Analysis of Copper and Copper Alloys (Photometric Methods) (Withdrawn 2010)  
 E75 Test Methods for Chemical Analysis of Copper-Nickel and Copper-Nickel-Zinc Alloys (Withdrawn 2010)  
 E76 Test Methods for Chemical Analysis of Nickel-Copper Alloys (Withdrawn 2003)  
 E112 Test Methods for Determining Average Grain Size  
 E118 Test Methods for Chemical Analysis of Copper-Chromium Alloys (Withdrawn 2010)  
 E243 Practice for Electromagnetic (Eddy Current) Examination of Copper and Copper-Alloy Tubes  
 E255 Practice for Sampling Copper and Copper Alloys for the Determination of Chemical Composition  
 E478 Test Methods for Chemical Analysis of Copper Alloys  
 E527 Practice for Numbering Metals and Alloys in the Unified Numbering System (UNS)  
 E2575 Standard Test Method for Determination of Oxygen in Copper and Copper Alloys (Withdrawn 2017)

## 3. Terminology

### 3.1 Definitions:

3.1.1 For definitions of terms relating to copper and copper alloys, refer to Terminology B846.

## 4. Ordering Information

4.1 Include the following specified choices when placing orders for product under this specification, as applicable:

- 4.1.1 ASTM Designation and year of issue;
- 4.1.2 Copper or Copper Alloy UNS No. Designation (see Table 1);

- 4.1.3 Temper (Section 7);
- 4.1.4 Dimensions, outside diameter, and wall thickness, whether minimum or nominal (Section 14);
- 4.1.5 How furnished (tube or ferrule stock);
- 4.1.6 Quantity—total weight or total length or number of pieces of each size; and
- 4.1.7 Intended application.

4.2 The following options are available but may not be included unless specified at the time of placing of the order when required:

- 4.2.1 DELETED
- 4.2.2 Hydrostatic or pneumatic test as an alternative to eddy current test (Section 13).
- 4.2.3 If the cut ends of the tubes do not need to be deburred (Section 15).
- 4.2.4 If the product is to be subsequently welded (Table 1, Footnotes G and H).
- 4.2.5 Residual Stress Test—Ammonia Vapor Test or Mercurous Nitrate Test (Section 12).
- 4.2.6 For Ammonia Vapor Test, risk level (pH value) if other than 10.
- 4.2.7 Heat identification or traceability details.
- 4.2.8 DELETED
- 4.2.9 DELETED
- 4.2.10 If a subsequent thermal treatment after straightening is required (Section 7).
- 4.2.11 If product is purchased for agencies of the U.S. Government (see Supplementary Requirements section of this specification for additional requirements, if required).

## 5. Materials and Manufacture

### 5.1 Materials:

5.1.1 The material of manufacture shall be a form of such purity and soundness as to be suitable for processing into the products prescribed herein.

5.1.2 When specified in the contract or purchase order that heat identification or traceability is required, the purchaser shall specify the details desired.

### 5.2 Manufacture:

5.2.1 The product shall be manufactured by such hot-working, cold-working, annealing, straightening, trimming, and other processes as to produce a uniform seamless tube in the finished product.

5.2.2 The product shall be hot- or cold-worked to the finished size, and subsequently annealed, when required, to meet the temper properties specified.

## 6. Chemical Composition

6.1 The product shall conform to the chemical composition requirements specified in Table 1.

TABLE 1 Chemical Requirements

Copper or Copper Alloy UNS No.	Composition, %												
	Copper	Tin	Aluminum	Nickel, incl Cobalt	Lead, max	Iron	Zinc	Manganese	Arsenic	Antimony	Phosphorus	Chromium	Other Named Elements
C10100	99.99 min <sup>A</sup>	0.0002 max	...	0.0010 max <sup>B</sup>	0.0005 max	0.0010 max	0.0001 max	0.00005 max	0.0005 max	0.0004 max	0.0003 max	0.0001 max	C
C10200 <sup>C</sup>	99.95 min <sup>D</sup>	...	...	...	...	...	...	...	...	...	...	...	C
C10300	99.95 min <sup>D</sup>	...	...	...	...	...	...	...	...	...	0.001–0.005	...	...
C10800	99.95 min <sup>D</sup>	...	...	...	...	...	...	...	...	...	0.005–0.012	...	...
C12000 <sup>E</sup>	99.90 min <sup>D</sup>	...	...	...	...	...	...	...	...	...	0.004–0.012	...	...
C12200	99.9 min <sup>D</sup>	...	...	...	...	...	...	...	...	...	0.015–0.040	...	...
C14200	99.4 min <sup>D</sup>	...	...	...	...	...	...	0.15–0.50	...	...	0.015–0.040	...	...
C15630	remainder	...	...	0.60–0.90 <sup>B</sup>	...	...	...	...	...	...	0.015–0.040	...	...
C19200	98.5 min	...	...	...	...	0.8–1.2	0.20 max	...	...	...	0.01–0.04	...	...
C23000	84.0–86.0	...	...	...	0.05	0.05 max	remainder	...	...	...	...	...	...
C28000	59.0–63.0	...	...	...	0.09	0.07 max	remainder	...	...	...	...	...	...
C44300	70.0–73.0	0.9–1.2	...	...	0.07	0.06 max	remainder	...	0.02–0.06	...	...	...	...
C44400	70.0–73.0	0.9–1.2	...	...	0.07	0.06 max	remainder	...	...	0.02–0.10	...	...	...
C44500	70.0–73.0	0.9–1.2	...	...	0.07	0.06 max	remainder	...	...	...	0.02–0.10	...	...
C60800	remainder <sup>D</sup>	...	5.0–6.5	...	0.10	0.10 max	...	...	0.02–0.35	...	...	...	...
C61300	remainder <sup>D</sup>	0.20–0.50	6.0–7.5	0.15 max	0.01	2.0–3.0	0.10 max	0.20 max	...	...	0.015 max	...	F, G
C61400	remainder <sup>D</sup>	...	6.0–8.0	...	0.01	1.5–3.5	0.20 max	1.0 max	...	...	0.015 max	...	...
C68700	76.0–79.0 <sup>D</sup>	...	1.8–2.5	...	0.07	0.06 max	remainder	...	0.02–0.06	...	...	...	...
C70400	remainder <sup>D</sup>	...	...	4.8–6.2	0.05	1.8–1.7	1.0 max	0.30–0.8	...	...	...	...	...
C70600	remainder <sup>D</sup>	...	...	9.0–11.0	0.05	1.0–1.8	1.0 max	1.0 max	...	...	...	...	...
C70620	86.5 min <sup>D</sup>	...	...	9.0–11.0	0.02	1.0–1.8	0.50 max	1.0 max	...	...	0.02 max	...	C.05 max S.02 max H
C71000	remainder <sup>D</sup>	...	...	19.0–23.0	0.05 <sup>H</sup>	0.50–1.0	1.0 max <sup>H</sup>	1.0 max	...	...	H	...	...
C71500	remainder <sup>D</sup>	...	...	29.0–33.0	0.05	0.40–1.0	1.0 max	1.0 max	...	...	...	...	...
C71520	65.0 min <sup>D</sup>	...	...	29.0–33.0	0.02	0.40–1.0	0.50 max	1.0 max	...	...	0.02 max	...	C.05 max S.02 max
C71640	remainder <sup>D</sup>	...	...	29.0–32.0	0.05 <sup>H</sup>	1.7–2.3	1.0 max <sup>H</sup>	1.5–2.5	...	...	H	...	C.06 max S.03 max <sup>H</sup>
C72200	remainder <sup>D</sup>	...	...	15.0–18.0	0.05 <sup>H</sup>	0.50–1.0	1.0 max <sup>H</sup>	1.0 max	...	...	H	0.30–0.70	Si.03 max Ti.03 max <sup>H</sup>

<sup>A</sup> This value is exclusive of silver and shall be determined by difference of "impurity total" from 100 %. "Impurity total" is defined as the sum of sulfur, silver, lead, tin, bismuth, arsenic, antimony, iron, nickel, mercury, zinc, phosphorus, selenium, tellurium, manganese, cadmium, and oxygen present in the sample.

<sup>B</sup> Not including Cobalt.

<sup>C</sup> Additional impurity maximums in percent for alloy C10100 shall be: bismuth 0.0001, cadmium 0.0001, oxygen 0.0005, selenium 0.0003, sulfur 0.0015, tellurium 0.0002, mercury 0.0001. For C10200, oxygen should be 0.0010 max.

<sup>D</sup> Copper (including silver).

<sup>E</sup> This includes oxygen-free Cu which contains P in an amount agreed upon.

<sup>F</sup> Silicon shall be 0.10 % max.

<sup>G</sup> When the product is for subsequent welding applications and is so specified by the purchaser, chromium shall be 0.05 % max, cadmium 0.05 % max, zinc 0.05 % max, and zirconium 0.05 % max.

<sup>H</sup> When the product is for subsequent welding applications, and so specified by the purchaser, zinc shall be 0.50 % max, lead 0.02 % max, phosphorus 0.02 % max, sulfur 0.02 % max, and carbon 0.05 % max.

ASMENORMDOC.COM : Click to view the full PDF (ASME BPVC.II.B (ASME BPVC Section II part B) 2025

6.2 These composition limits do not preclude the presence of other elements. By agreement between the manufacturer and purchaser, limits may be established and analysis required for unnamed elements.

6.2.1 *Copper Alloy UNS No. C19200*—Copper is the difference between the sum results of all the elements determined and 100 %. When all the elements in Table 1 are determined, their sum shall be 99.8 % minimum.

6.2.2 For alloys in which copper is listed as “remainder,” copper is the difference between the sum results of all the elements determined and 100 %. When all elements in Table 1 are determined, the sum of the results shall be as follows:

Copper Alloy UNS No.	Copper Plus Named Elements, % min
C15630	99.5
C60800	99.5
C61300	99.8
C61400	99.5
C70400	99.5
C70600 & C70620	99.5
C71000	99.5
C71500 & C71520	99.5
C71640	99.5
C72200	99.8

6.2.3 For alloys in which zinc is listed as the remainder, either copper or zinc may be taken as the difference between the sum of all the elements determined and 100 %. When all elements in Table 1 are determined, the sum of the results shall be as follows:

Copper Alloy UNS No.	Copper Plus Named Elements, % min
C23000	99.8
C28000	99.7
C44300	99.6
C44400	99.6
C44500	99.6
C68700	99.5

## 7. Temper

7.1 Tubes shall be furnished in the temper designations identified in Tables 2 and 3.

7.1.1 Drawn tempers H55 and H80.

7.1.2 Annealed temper O61.

7.1.3 Drawn and stress-relieved temper HR50.

7.2 Tubes for ferrule stock shall be annealed sufficiently to be fully recrystallized.

7.3 *Optional Post-Straightening Thermal Treatment*—Some tubes, when subjected to aggressive environments, may have the potential for stress-corrosion cracking failure due to the residual stresses induced during straightening processing. For such applications, it is suggested that tubes of Copper Alloy UNS Nos. C23000, C28000, C44300, C44400, C44500, C60800, C61300, C61400, and C68700 be subjected to a stress-relieving thermal treatment subsequent to straightening. If required, this must be specified on the purchase order or

TABLE 2 Tensile Requirements—Inch-Pound Values

NOTE 1—See Table 3 for tensile requirements—SI values.

Copper or Copper Alloy UNS No.	Temper Designation		Tensile Strength, min ksi <sup>A</sup>	Yield Strength, <sup>B</sup> min ksi <sup>A</sup>	Elongation in 2 in., min %
	Code	Name			
C10100, C10200, C10300, C10800, C12000, C12200, C14200	H55	light-drawn	36	30	...
C10100, C10200, C10300, C10800, C12000, C12200, C14200	H80	hard-drawn	45	40	...
C15630	O61	annealed	30	8	40
C19200	H55	light-drawn	40	35	...
C19200	H80	hard-drawn	48	43	...
C19200	O61	annealed	38	12	...
C23000	O61	annealed	40	12	...
C28000	O61	annealed	50	20	...
C44300, C44400, C44500	O61	annealed	45	15	...
C60800	O61	annealed	50	19	...
C61300, C61400	O61	annealed	70	30	...
C68700	O61	annealed	50	18	...
C70400	O61	annealed	38	12	...
C70400	H55	light-drawn	40	30	...
C70600, C70620	O61	annealed	40	15	...
C70600, C70620	H55	light-drawn	45	35	...
C71000	O61	annealed	45	16	...
C71500, C71520	O61	annealed	52	18	...
C71500, C71520					
Wall thicknesses up to 0.048 in., incl	HR50	drawn and stress-relieved	72	50	12
Wall thicknesses over 0.048 in.	HR50	drawn and stress-relieved	72	50	15
C71640	O61	annealed	63	25	...
C71640	HR50	drawn and stress relieved	81	58	...
C72200	O61	annealed	45	16	...
C72200	H55	light-drawn	50	45	...

<sup>A</sup> ksi = 1000 psi.

<sup>B</sup> At 0.5 % extension under load.

TABLE 3 Tensile Requirements—SI Values

NOTE 1—See Table 2 for tensile requirements—inch-pound values.

Copper or Copper Alloy UNS No.	Temper Designation		Tensile Strength, min MPa	Yield Strength, <sup>A</sup> min MPa	Elongation in 50 mm, min %
	Code	Name			
C10100, C10200, C10300, C10800, C12000, C12200, C14200	H55	light-drawn	250	205	...
C10100, C10200, C10300, C10800, C12000, C12200, C14200	H80	hard-drawn	310	275	...
C15630	O61	annealed	205	55	40
C19200	H55	light-drawn	275	240	...
C19200	H80	hard-drawn	330	295	...
C19200	O61	annealed	260	85	...
C23000	O61	annealed	275	85	...
C28000	O61	annealed	345	140	...
C44300, C44400, C44500	O61	annealed	310	105	...
C60800	O61	annealed	345	130	...
C61300, C61400	O61	annealed	480	205	...
C68700	O61	annealed	345	125	...
C70400	O61	annealed	260	85	...
C70400	H55	light-drawn	275	205	...
C70600, C70620	O61	annealed	275	105	...
C70600, C70620	H55	light-drawn	310	240	...
C71000	O61	annealed	310	110	...
C71500, C71520	O61	annealed	360	125	...
C71500, C71520: Wall thicknesses up to 1.2 mm incl	HR50	drawn and stress-relieved	495	345	12
Wall thicknesses over 1.2 mm.	HR50	drawn and stress-relieved	495	345	15
C71640	O61	annealed	435	170	...
C71640	HR50	drawn and stress relieved	560	400	...
C72200	O61	annealed	310	110	...
C72200	H55	light-drawn	345	310	...

<sup>A</sup> At 0.5 % extension under load.

contract. Tolerances for roundness and length, and the condition of straightness, for tube so ordered, shall meet the requirements agreed upon by the manufacturer and the purchaser.

## 8. Mechanical Properties

8.1 Material shall have tensile properties as prescribed in Table 2 or Table 3.

## 9. Grain Size for Annealed Tempers

9.1 Grain size shall be the standard requirement for all product in the annealed (O61) temper.

9.1.1 Other than Copper Alloy UNS Nos. C19200 and C28000, acceptance or rejection for all annealed products shall depend only on average grain size of the test specimen within the limits of 0.010 to 0.045 mm taken from each of two sample portions, and each specimen shall be within the limits prescribed herein when determined in accordance with Test Methods E112.

## 10. Performance Requirements

### 10.1 Expansion Test:

10.1.1 Tube specimens selected for test shall withstand the expansion shown in Table 4 when expanded in accordance with Test Method B153. The expanded tube shall show no cracking or rupture visible to the unaided eye.

10.2 Hard-drawn tubes not end annealed are not subject to this test. When tubes are specified end annealed, this test is required and shall be performed on the annealed ends of the sampled tubes.

10.3 Tubes for ferrule stock are not subject to the expansion test.

## 11. Flattening Test

11.1 *Test Method*—Each test specimen shall be inspected per Test Method B968/B968M.

11.2 During inspection, the flattened areas of the test-specimen shall be free of defects, but blemishes of a nature that do not interfere with the intended application are acceptable.

11.3 Tubes for ferrule stock are not subject to flattening test.

## 12. Residual Stress Test

12.1 A residual stress test, when specified in the purchase order, is required only for Copper Alloy UNS Nos. C23000, C28000, C44300, C44400, C44500, C60800, C61300, C61400, and C68700 and when not supplied in an annealed temper.

12.2 Unless otherwise specified, the producer shall have the option of testing the product to either the mercurous nitrate test, Test Method B154, or the ammonia vapor test, Test Method B858, as prescribed below.

### 12.2.1 Mercurous Nitrate Test:

12.2.1.1 **Warning**—Mercury is a definite health hazard and therefore equipment for the detection and removal of mercury vapor produced in volatilization is recommended. The use of rubber gloves in testing is advisable.

12.2.1.2 The test specimens, cut 6 in. [150 mm] in length, shall withstand without cracking, an immersion in the standard mercurous nitrate solution prescribed in Test Method B154. The test specimen shall include the finished tube end.

TABLE 4 Expansion Requirements

Temper Designation		Copper or Copper Alloy UNS No.	Expansion of Tube Outside Diameter, in Percent of Original Outside Diameter
Code	Name		
O61	annealed	C15630	40
		C19200	30
		C23000	20
		C28000	15
		C44300, C44400, C44500	20
		C60800	20
		C61300, C61400	20
		C68700	20
		C70400	30
		C70600, C70620	30
		C71000	30
		C71500, C71520	30
		C71640	30
		C72200	30
H55	light-drawn	C10100, C10200, C10300, C10800, C12000, C12200	20
		C14200	20
		C19200	20
		C70400	20
		C70600, C70620	20
		C72200	20
		C71500, C71520	20
HR50	drawn and stress relieved	C71640	20
		C71500, C71520	20
...	hard-drawn and end annealed	C10100, C10200, C10300, C10800, C12000, C12200, C14200	30

### 12.2.2 Ammonia Vapor Test:

12.2.2.1 The test specimens, cut 6 in. [150 mm] in length, shall withstand without cracking, the ammonia vapor test as prescribed in Test Method B858. For the purposes of this specification, unless otherwise agreed between purchaser and supplier, the risk level identified in the Annex of Method B858, shall be specified as risk level (pH value) of 10.

## 13. Nondestructive Testing

13.1 Each tube shall be subjected to the eddy-current test in 13.1.1. Tubes may be tested in the final drawn, annealed, or heat-treated temper or in the drawn temper before the final anneal or heat treatment unless otherwise agreed upon by the supplier and the purchaser. The purchaser may specify either of the tests in 13.1.2 or 13.1.3 as an alternative to the eddy-current test.

13.1.1 *Eddy-Current Test*—Each tube shall be passed through an eddy-current testing unit adjusted to provide information on the suitability of the tube for the intended application. Testing shall follow the procedures of Practice E243.

13.1.1.1 The depth of the round-bottom transverse notches or the diameters of the drilled holes in the calibrating tube used to adjust the sensitivity of the test unit are shown in Tables 5 and 6, and Tables 7 and 8, respectively. Notches of less depth and smaller diameter drilled holes are acceptable to meet this requirement.

13.1.1.2 Tubes that do not actuate the signaling device of the eddy-current tester shall be considered to conform to the requirements of this test. Tubes causing irrelevant signals because of moisture, soil, and like effects may be reconditioned and retested. Such tubes, when retested to the original test parameters, shall be considered to conform if they do not cause output signals beyond the acceptable limits. Tubes causing

TABLE 5 Notch Depth—Inch-Pound Values

NOTE 1—See Table 6 for notch depth—SI values.

Tube Wall Thickness, in.	Tube Outside Diameter, in.		
	Over 1/4 to 3/4, incl	Over 3/4 to 1 1/4, incl	Over 1 1/4 to 3 1/2, incl
Over 0.017–0.032	0.005	0.006	0.007
Incl 0.032–0.049	0.006	0.006	0.0075
Incl 0.049–0.083	0.007	0.0075	0.008
Incl 0.083–0.109	0.0075	0.0085	0.0095
Incl 0.109–0.120	0.009	0.009	0.011

TABLE 6 Notch Depth—SI Values

NOTE 1—See Table 5 for notch depth—inch-pound values.

Tube Wall Thickness, mm	Tube Outside Diameter, mm		
	Over 6 to 19, incl	Over 19 to 32, incl	Over 32 to 80, incl
Over 0.4–0.8	0.13	0.15	0.18
Incl 0.8–1.3	0.15	0.15	0.19
Incl 1.3–2.1	0.18	0.19	0.20
Incl 2.1–2.8	0.19	0.22	0.24
Incl 2.8–3.0	0.23	0.23	0.28

irrelevant signals because of visible and identifiable handling marks may be retested by the hydrostatic test prescribed in 13.1.2, or the pneumatic test prescribed in 13.1.3. Tubes meeting requirements of either test shall be considered to conform if the tube dimensions are within the prescribed limits, unless otherwise agreed upon between the manufacturer and the purchaser.

13.1.2 *Hydrostatic Test*—Each tube shall stand, without showing evidence of leakage, an internal hydrostatic pressure sufficient to subject the material to a fiber stress of 7000 psi [48 MPa] as determined by the following equation for thin

**TABLE 7 Diameter of Drilled Holes—Inch-Pound Values**

NOTE 1—See Table 8 for diameter of drilled holes—SI values.

Tube Outside Diameter, in.	Diameter of Drilled Holes, in.	Drill No.
¼ –¾, incl	0.025	72
Over ¾ –1, incl	0.031	68
Over 1–1¼, incl	0.036	64
Over 1¼ –1½, incl	0.042	58
Over 1½ –1¾, incl	0.046	56
Over 1¾ –2, incl	0.052	55

**TABLE 8 Diameter of Drilled Holes—SI Values**

NOTE 1—See Table 7 for diameter of drilled holes—inch-pound values.

Tube Outside Diameter, mm	Diameter of Drilled Holes, mm	Drill No.
6.0–19.0, incl	0.65	72
Over 19.0–25.4, incl	0.80	68
Over 25.4–31.8, incl	0.92	64
Over 31.8–38.1, incl	1.1	58
Over 38.1–44.4, incl	1.2	56
Over 44.4–50.8, incl	1.3	55

hollow cylinders under tension. The tube need not be tested at a hydrostatic pressure of over 1000 psi [7.0 MPa] unless so specified.

$$P = 2St/(D - 0.8t)$$

where:

- P = hydrostatic pressure, psig [MPa];
- t = thickness of tube wall, in. [mm];
- D = outside diameter of the tube, in. [mm]; and
- S = allowable stress of the material, psi [MPa].

13.1.3 *Pneumatic Test*—Each tube shall be subjected to an internal air pressure of 60 psig [400 kPa], min, for 5 s without showing evidence of leakage. The test method used shall permit easy visual detection of any leakage, such as by having the tube under water or by the pressure differential method. Any evidence of leakage shall be cause for rejection.

**14. Dimensions and Permissible Variations**

14.1 *Diameter*—The outside of the tubes shall not vary from that specified by more than the amounts shown in Table 9 or Table 10 as measured by “go” and “no-go” ring gages.

**TABLE 9 Diameter Tolerances—Inch-Pound Values**

NOTE 1—See Table 10 for diameter tolerances—SI values.

Outside Diameter, in.	Wall Thickness, in.				
	0.020 <sup>A</sup>	0.032	0.035	0.042	0.049 and Over
	0.022				
	0.025				
	0.028				
Diameter Tolerance, Plus and Minus, in.					
Up to 0.500, incl	0.003	0.0025	0.0025	0.0025	0.0025
Over 0.500–0.740, incl	0.0040	0.004	0.004	0.0035	0.003
Over 0.740–1.000, incl	0.0060	0.006	0.005	0.0045	0.004
Over 1.000–1.250, incl	...	0.009	0.008	0.006	0.0045
Over 1.250–1.375, incl	...	...	...	0.008	0.005
Over 1.375–2.000, incl	...	...	...	...	0.006
Over 2.000–3.125, incl	...	...	...	...	0.0065

<sup>A</sup> Tolerances in this column are applicable to light drawn and drawn tempers only. Tolerances for annealed tempers shall be as agreed upon between the manufacturer and the purchaser.

Alternatively, micrometers may be used to ensure outer diameter tolerance at any one point; however, in cases of dispute, ring gauges shall be used for final determination.

14.2 *Wall Thickness Tolerances:*

14.2.1 *Tubes Ordered to Minimum Wall*—No tube wall at its thinnest point shall be less than the specified wall thickness. The maximum plus deviation from the specified wall at any point shall not exceed twice the values shown in Tables 11 and 12.

14.2.2 *Tubes Ordered to Nominal Wall*—The maximum plus and minus deviation from the nominal wall at any point shall not exceed the values shown in Tables 11 and 12.

14.3 *Length*—The length of the tubes shall not be less than that specified when measured at room temperature, but may exceed the specified value by the amounts given in Tables 13 and 14.

14.4 *Squareness of Cut*—The departure from squareness of the end of the tube shall not exceed the following:

Tube, Outside Diameter, in. [mm]	Tolerance, in. [mm]
Up to ¾ [16], incl	0.010 in. [0.25]
Over ¾ [16]	0.016 in./in. [mm/mm] of diameter

14.5 For the purpose of determining conformance with the dimensional requirements prescribed in this specification, any measured value outside the specified limiting values for any dimensions may be cause for rejection.

**15. Workmanship, Finish, and Appearance**

15.1 Roundness, straightness, uniformity of the wall thickness, and inner and outer surface of the tube shall be such as to make it suitable for the intended application. Unless otherwise specified on the purchase order, the cut ends of the tubes shall be deburred by use of a rotating wire wheel or other suitable tool.

15.2 Annealed-temper or thermally stress-relieved tubes shall be clean and smooth but may have a superficial, dull iridescent film on both the inside and the outside surface. Drawn-temper tubes shall be clean and smooth, but may have a superficial film of drawing lubricant on the surfaces.

TABLE 10 Diameter Tolerances—SI Values

NOTE 1—See Table 9 for diameter tolerances—inch-pound values.

Outside Diameter, mm	Wall Thickness, mm				
	0.508 <sup>A</sup> 0.559 0.635 0.711	0.813	0.889	1.07	1.24 and Over
	Diameter Tolerance, Plus and Minus, mm				
Up to 12, incl	0.076	0.064	0.064	0.064	0.064
Over 12–18, incl	0.10	0.10	0.10	0.089	0.076
Over 18–25, incl	0.15	0.15	0.13	0.11	0.10
Over 25–35, incl	...	...	...	0.20	0.13
Over 35–50, incl	...	...	...	...	0.15
Over 50–79, incl	...	...	...	...	0.17

<sup>A</sup> Tolerances in this column are applicable to light drawn and drawn tempers only. Tolerances for annealed tempers shall be as agreed upon between the manufacturer and the purchaser.

TABLE 11 Wall Thickness Tolerances, Plus and Minus—Inch-Pound Values

NOTE 1—See Table 12 for SI values.

Wall Thickness, in.	Outside Diameter, in.			
	Over 1/8 to 5/8, incl	Over 5/8 to 1, incl	Over 1 to 2, incl	Over 2 to 3.125, incl
0.020, incl to 0.032	0.003	0.003	...	...
0.032, incl to 0.035	0.003	0.003	0.004	...
0.035, incl to 0.058	0.004	0.0045	0.0045	0.005
0.058, incl to 0.083	0.0045	0.005	0.005	0.0055
0.083, incl to 0.120	0.005	0.0065	0.0065	0.0065
0.120, incl to 0.134	0.007	0.007	0.0075	0.008

TABLE 12 Wall Thickness Tolerances, Plus and Minus—SI Values

NOTE 1—See Table 11 for inch-pound values.

Wall Thickness, mm	Outside Diameter, mm		
	Over 12 to 25, incl	Over 25 to 50, incl	Over 50 to 80, incl
0.50, incl to 0.80	0.08	...	...
0.80, incl to 0.90	0.08	0.10	...
0.90, incl to 1.5	0.11	0.11	0.13
1.5, incl to 2.1	0.13	0.13	0.14
2.1, incl to 3.0	0.17	0.17	0.17
3.0, incl to 3.4	0.18	0.19	0.20

TABLE 13 Length Tolerances—Inch-Pound Values

NOTE 1—See Table 14 for SI values.

Specified Length, ft	Tolerance, all Plus, in.
Up to 15	3/32
Over 15–20, incl	1/8
Over 20–30, incl	5/32
Over 30–60, incl	3/8
Over 60–100, incl <sup>A</sup>	1/2

<sup>A</sup> Condenser tubes in lengths over 100 ft are not in demand at present. Tolerance values for the lengths will be developed as experience dictates. Tolerance values for lengths in wall thicknesses of 0.020, incl. to 0.032 shall be as agreed upon between the manufacturer or supplier and the purchaser.

## 16. Sampling

16.1 *Sampling*—The lot size, portion size, and selection of sample pieces shall be as follows:

TABLE 14 Length Tolerances—SI Values

NOTE 1—See Table 13 for inch-pound values.

Specified Length, mm	Tolerance, all Plus, mm
Up to 4500	2.4
Over 4500–6000, incl	3.2
Over 6000–10 000, incl	4.0
Over 10 000–18 000, incl	9.5
Over 18 000–30 000, incl <sup>A</sup>	13.0

<sup>A</sup> Condenser tubes in lengths over 30 000 mm are not in demand at present. Tolerance values for the lengths will be developed as experience dictates. Tolerance values for lengths in wall thicknesses of 0.5, inclusive to 0.8 shall be as agreed upon between the manufacturer or supplier and the purchaser.

16.1.1 *Lot Size*—600 tubes or 10 000 lb [4550 kg] or fraction of either, whichever constitutes the greater weight.

16.1.2 *Portion Size*—Sample pieces from two individual lengths of finished product.

16.2 Samples taken for the purpose of the tests prescribed in the specification shall be selected in a manner that will represent correctly the material furnished and avoid needless destruction of finished material when samples representative of the material are available from other sources.

16.3 *Chemical Analysis*—Samples for chemical analysis shall be taken in accordance with Practice E255. Drillings, millings, and so forth shall be taken in approximately equal weight from each of the sample pieces selected in accordance with 16.1.2 and combined into one composite sample. The minimum weight of the composite sample that is to be divided into three equal parts shall be 150 g.

16.3.1 Alternatively to sampling procedures in accordance with Practice E255, the manufacturer shall have the option of determining conformance to chemical composition as follows: Conformance shall be determined by the manufacturer by analyzing samples taken at the time the castings are poured or samples taken from the semifinished product. If the manufacturer determines the chemical composition of the material during the course of manufacture, he shall not be required to sample and analyze the finished product. The number of samples taken for determination of chemical composition shall be as follows:

16.3.1.1 When samples are taken at the time the castings are poured, at least one sample shall be taken for each group of castings poured simultaneously from the same source of molten metal.

16.3.1.2 When samples are taken from the semifinished product, a sample shall be taken to represent each 10 000 lb [4550 kg] or fraction thereof, except that not more than one sample shall be required per piece.

16.3.1.3 Because of the discontinuous nature of the processing of castings into wrought products, it is not practical to identify specific casting analysis with a specific quantity of finished material.

16.3.1.4 In the event that heat identification or traceability is required, the purchaser shall specify the details desired at the time of order placement.

## 17. Number of Tests and Retests

### 17.1 Test:

17.1.1 *Chemical Analysis*—Chemical composition shall be determined as per the element mean of the results from at least two replicate analyses of the sample(s).

17.1.2 *Other Tests*—For tests specified in Sections 8 – 12 inclusive, specimens shall be taken from each of the pieces selected in accordance with 16.1.2.

17.1.3 If any test specimen representing a lot fails to conform to the requirements of Sections 6 – 12, two additional specimens, at the option of the manufacturer, may be taken as before, and submitted for check analysis or subjected to any tests in which the original specimen failed, but each of these specimens shall conform to the requirements specified.

### 17.2 Retest:

17.2.1 When requested by the manufacturer or supplier, a retest shall be permitted when results of tests obtained by the purchaser fail to conform to the requirements of the product specification.

17.2.2 The retest shall be as directed in the product specification for the initial test, except the number of test specimens shall be twice that normally required for the specified test.

17.2.3 All test specimens shall conform to the product specification requirement(s) in retest. Failure to conform shall be cause for rejection.

## 18. Specimen Preparation

18.1 *Flattening Test*—Prepare specimen as per Test Method B968/B968M.

18.2 *Expansion Test*—Prepare specimen as per Test Method B153.

18.3 *Mercurous Nitrate Test*—Prepare specimen as per Test Method B154.

18.4 *Ammonia Vapor Test*—Prepare specimen as per Test Method B858.

18.5 *Chemical Analysis*—Prepare specimens as per Test Method listed (see 19.1).

18.6 *Grain Size*—Prepare specimens per Test Methods E112.

18.6.1 The surface of the test specimen for microscopical examination shall approximate a radial longitudinal section of the tube.

18.7 *Tension Testing*—Tubes selected for test shall be subjected to the tension test which shall, in case of disagreement, be performed in accordance with Test Methods E8/E8M. Tension test specimen shall be of the full section of the tube and shall conform to the requirements of the section, Specimens for Pipe and Tube, of Test Methods E8/E8M, unless the limitations of the testing machine preclude the use of such a specimen. Test specimens conforming to Type No. 1 of Fig. 13, Tension Test Specimens for Large-Diameter Tubular Products, of Test Methods E8/E8M may be used when a full section specimen cannot be tested.

## 19. Test Methods

### 19.1 Chemical Analyses:

19.1.1 In cases of disagreement, test methods for chemical analysis shall be subject to agreement between the manufacturer or supplier and the purchaser. The following published methods, some of which may no longer be viable, which along with others not listed, may be used, subject to agreement:

Test	ASTM Designation
Chemical analysis	B170, <sup>A</sup> E53, E54, E62, E75, E76, E118, E478

<sup>A</sup> Reference to Specification B170 is to the suggested chemical methods in the annex thereof. When E01 Committee has tested and published methods for assaying the low-level impurities in copper, the Specification B170 annex will be eliminated.

19.1.2 Test methods to be followed for the determination of elements resulting from contractual or purchase order agreement shall be as agreed upon between the manufacturer or supplier and the purchaser.

### 19.2 Other Tests:

19.2.1 The product furnished shall conform to specified requirements when subjected to test in accordance with the following table:

Test	ASTM Designation
Grain size	E112
Expansion (pin test)	B153
Mercurous nitrate	B154
Tension	E8/E8M
Nondestructive test	E243

19.2.2 Whenever tension test results are obtained from both full-size and machined specimens and they differ, the results obtained from full-size test specimens shall be used to determine conformance to the specification requirements.

19.2.3 Tension test results on material covered by this specification are not seriously affected by variations in speed of testing. A considerable range of testing speed is permissible; however, the range of stressing to the yield strength should not exceed 100 ksi/min [690 MPa/min]. Above this yield strength the movement per minute of the testing machine head under load should not exceed 0.5 in./in. [mm/mm] of gage length (or distance between grips for full-section specimens).

## 20. Significance of Numerical Limits

20.1 For the purpose of determining compliance with the specified limits for requirements of the properties listed in the following table, and for dimensional tolerances, an observed value or a calculated value shall be rounded as indicated in accordance with the rounding method of Practice E29:

Property	Rounded Unit for Observed or Calculated Value
Chemical composition	nearest unit in the last right-hand significant digit used in expressing the limiting value
Tensile strength	nearest ksi, for over 10 to 100 ksi, incl
Yield strength	[nearest 5 MPa]
Elongation	nearest 1 %
Grain size—under 0.060 mm	nearest multiple of 0.005 mm
0.060 mm and over	nearest 0.01 mm

## 21. Inspection

21.1 The manufacturer, or supplier, shall inspect and make tests necessary to verify the furnished product conforms to specification requirements.

21.2 Source inspection of the product by the purchaser may be agreed upon between the manufacturer, or supplier, and the purchaser as part of the purchase order. In such case, the nature of the facilities needed to satisfy the inspector, representing the purchaser, that the product is being furnished in accordance with the specification shall be included in the agreement. All testing and inspection shall be conducted so as not to interfere unnecessarily with the operation of the works.

21.3 When mutually agreed upon, the manufacturer, or supplier, and the purchaser shall conduct the final inspection simultaneously.

## 22. Rejection and Rehearing

### 22.1 Rejection:

22.1.1 Product that fails to conform to the specification requirements when tested by the purchaser or purchaser's agent shall be subject to rejection.

22.1.2 Rejection shall be reported to the manufacturer or supplier promptly. In addition, a written notification of rejection shall follow.

22.1.3 In case of dissatisfaction with results of the test upon which rejection is based, the manufacturer, or supplier, shall have the option to make claim for a rehearing.

### 22.2 Rehearing:

22.2.1 As a result of product rejection, the manufacturer, or supplier, shall have the option to make claim for a retest to be conducted by the manufacturer, or supplier, and the purchaser. Samples of the rejected product shall be taken in accordance with the product specification and subjected to test by both parties using the test method(s) specified in the product specification, or alternately, upon agreement of both parties, an independent laboratory may be selected for the test(s) using the test method(s) specified in the product specification.

## 23. Certification

23.1 The purchaser shall be furnished certification that samples representing each lot have been either tested or inspected as directed in this specification and requirements have been met.

23.2 DELETED

## 24. Test Report

24.1 A report of test results shall be furnished.

## 25. Packaging and Package Marking

25.1 The material shall be separated by size, composition, and temper, and prepared for shipment in such a manner as to ensure acceptance by common carrier for transportation and to afford protection from the normal hazards of transportation.

25.2 Each shipping unit shall be legibly marked with the purchase order number, metal or alloy designation, temper, size, shape, total length or piece count, or both, and name of supplier. The specification number shall be shown, when specified.

## 26. Keywords

26.1 condenser tube; copper; copper alloys; evaporator; ferrule stock; heat exchanger; seamless tube; UNS No. C10100; UNS No. C10200; UNS No. C10300; UNS No. C10800; UNS No. C12000; UNS No. C12200; UNS No. C14200; UNS No. C15630; UNS No. C19200; UNS No. C23000; UNS No. C28000; UNS No. C44300; UNS No. C44400; UNS No. C44500; UNS No. C60800; UNS No. C61300; UNS No. C61400; UNS No. C68700; UNS No. C70400; UNS No. C70600; UNS No. C70620; UNS No. C71000; UNS No. C71500; UNS No. C71520; UNS No. C71640; UNS No. C72200

## SUPPLEMENTARY REQUIREMENTS

The following supplementary requirements shall apply only when specified by the purchaser in the inquiry, contract, or order, for agencies of the U.S. government.

### S1. Referenced Documents

S1.1 The following documents of the issue in effect on date of material purchase form a part of this specification to the extent referenced herein:

#### S1.1.1 *Federal Standards:*

Fed. Std. No. 102 Preservation, Packaging and Packing Levels

Fed. Std. No. 123 Marking for Shipment (Civil Agencies)

Fed. Std. No. 185 Identification Marking of Copper and Copper-Base Alloy Mill Products

#### S1.1.2 *Military Standard:*

MIL-STD-129 Marking for Shipment and Storage

#### S1.1.3 *Military Specification:*

B900 Specification for Packaging of Copper and Copper Alloy Mill Products for U.S. Government Agencies

### S2. Quality Assurance

S2.1 *Responsibility for Inspection*—Unless otherwise specified in the contract or purchase order, the manufacturer is responsible for the performance of all inspection and test requirements specified. Except as otherwise specified in the contract or purchase order, the manufacturer may use his own or any other suitable facilities for the performance of the inspection and test requirements unless disapproved by the

purchaser at the time the order is placed. The purchaser shall have the right to perform any of the inspections or tests set forth when such inspections and tests are deemed necessary to assure that the material conforms to prescribed requirements.

### S3. Identification Marking

S3.1 All material shall be properly marked for identification in accordance with Fed. Std. No. 185 except that the ASTM specification number and the alloy number shall be used.

### S4. Preparation for Delivery

#### S4.1 *Preservation, Packaging, Packing:*

S4.1.1 *Military Agencies*—The material shall be separated by size, composition, grade or class and shall be preserved and packaged, Level A or C, packed Level A, B, or C as specified in the contract or purchase order, in accordance with the requirements of ASTM B900.

S4.1.2 *Civil Agencies*—The requirements of Fed. Std. No. 102 shall be referenced for definitions of the various levels of packaging protection.

#### S4.2 *Marking:*

S4.2.1 *Military Agencies*—In addition to any special marking required by the contract or purchase order, marking for shipment shall be in accordance with MIL-STD-129.

S4.2.2 *Civil Agencies*—In addition to any special marking required by the contract or purchase order, marking for shipment shall be in accordance with Fed. Std. No. 123.

## APPENDIX

(Nonmandatory Information)

### X1. DENSITY OF COPPER AND COPPER ALLOYS

X1.1 The densities of the alloys covered by this specification are given in Table X1.1.

TABLE X1.1 Densities

NOTE 1—This information is for reference only.

Copper or Copper Alloy UNS No.	Density, lb/in. <sup>3</sup>	Density, g/cm <sup>3</sup>
C10100, C10200, C10300, C10800, C12000, C12200, C14200	0.323	8.94
C15630	0.320	8.87
C19200	0.320	8.86
C23000	0.316	8.75
C28000	0.303	8.39
C44300, C44400, C44500	0.308	8.53
C60800	0.295	8.17
C61300, C61400	0.285	7.89
C68700	0.301	8.33
C70400	0.323	8.94
C70600, C70620	0.323	8.94
C71000	0.323	8.94
C71500, C71520	0.323	8.94
C71640	0.323	8.94
C72200	0.323	8.94

ASMENORMDOC.COM : Click to view the full PDF of ASME BPVC.II.B (ASME BPVC Section II part B) 2025

INTENTIONALLY LEFT BLANK

# SPECIFICATION FOR NICKEL-COPPER ALLOY (UNS N04400) PLATE, SHEET, AND STRIP



SB-127

(Identical with ASTM Specification B127-05 (2014) except that certification has been made mandatory.)

ASME NORMDOC.COM : Click to view the full PDF of ASME BPVC.II.B (ASME BPVC Section II part B) 2025

# SPECIFICATION FOR NICKEL-COPPER ALLOY (UNS N04400) PLATE, SHEET, AND STRIP



SB-127

[Identical with ASTM Specification B 127-05(2014) except that certification has been made mandatory.]

## 1. Scope

**1.1** This specification covers rolled nickel-copper alloy (UNS N04400) plate, sheet, and strip.

**1.2** The values stated in inch-pound units are to be regarded as the standard. The other values given are for information only.

**1.3** *This standard does not purport to address all of the safety concerns, if any, associated with its use. It is the responsibility of the user of this standard to become familiar with all hazards including those identified in the appropriate Material Safety Data Sheet for this product/material as provided by the manufacturer, to establish appropriate safety and health practices, and determine the applicability of regulatory limitations prior to use.*

## 2. Referenced Documents

### 2.1 ASTM Standards:

B 906 Specification for General Requirements for Flat-Rolled Nickel and Nickel Alloys Plate, Sheet, and Strip  
E 140 Hardness Conversion Tables for Metals  
F 155 Test Method for Temper of Strip and Sheet Metals for Electronic Devices (Spring-Back Method)

### 2.2 Federal Standards:

Fed. Std. No. 102 Preservation, Packaging, and Packing Levels  
Fed. Std. No. 123 Marking for Shipment (Civil Agencies)  
Fed. Std. No. 182 Continuous Identification Marking of Nickel and Nickel-Base Alloys

### 2.3 Military Standards:

MIL-STD-129 Marking for Shipment and Storage  
MIL-STD-271 Nondestructive Testing Requirements for Metals

## 3. Terminology

**3.1** *Descriptions of Terms Specific to This Standard* — The terms given in Table 1 shall apply.

## 4. General Requirements

**4.1** Material furnished under this specification shall conform to the applicable requirements of Specification B 906 unless otherwise provided herein.

## 5. Ordering Information

**5.1** It is the responsibility of the purchaser to specify all requirements that are necessary for material ordered under this specification. Examples of such requirements include, but are not limited to the following:

**5.1.1** *Alloy* — Name or UNS number (see Table 2).

**5.1.2** *ASTM designation*, including year of issue.

**5.1.3** *Condition* — See 7.1, 7.2, and Appendix X1.

**5.1.4** *Finish* — See Appendix X1.

**5.1.5** *Dimensions* — Thickness, width, and length.

TABLE 1  
PRODUCT DESCRIPTION

Product	Thickness, in. (mm)
Hot-rolled plate <sup>A</sup>	$\frac{3}{16}$ and over
Hot-rolled sheet <sup>A</sup>	0.018 to 0.250 (0.46 to 6.4), incl
Cold-rolled sheet <sup>B</sup>	0.018 to 0.250 (0.46 to 6.4), incl
Cold-rolled strip <sup>B</sup>	0.005 to 0.250 (0.13 to 6.4), incl

<sup>A</sup> Material  $\frac{3}{16}$  to  $\frac{1}{4}$  in. (4.8 to 6.4 mm), incl, in thickness may be furnished as sheet or plate provided the material meets the specification requirements for the condition ordered.

<sup>B</sup> Material under 48 in. (1219 mm) in width may be furnished as sheet or strip provided the material meets the specification requirements for the condition ordered.

TABLE 2  
CHEMICAL REQUIREMENTS

Element	Composition, %
	Alloy N04400
Nickel, min <sup>4</sup>	63.0
Copper	28.0 to 34.0
Iron, max	2.5
Manganese, max	2.0
Carbon, max	0.3
Silicon, max	0.5
Sulfur, max	0.024

<sup>4</sup> Element shall be determined arithmetically by difference.

### 5.1.6 Quantity.

### 5.1.7 Optional Requirements:

**5.1.7.1 Sheet and Strip** — Whether to be furnished in coil, in cut straight lengths, or in random straight lengths.

**5.1.7.2 Strip** — Whether to be furnished with commercial slit edge, square edge, or round edge.

**5.1.7.3 Plate** — Whether to be furnished specially flattened (7.2); also how plate is to be cut (8.2.1 and 8.3.2).

**5.1.8 Fabrication Details** — Not mandatory but helpful to the manufacturer.

**5.1.8.1 Welding or Brazing** — Process to be employed.

**5.1.8.2 Plate** — Whether material is to be hot-formed.

**5.1.9 Certification** — Certification and a report of test results are required (see Specification B 906, section on Material Test Report and Certification).

**5.1.10 Samples for Product (Check) Analysis** — Whether samples for product (check) analysis should be furnished (see Specification B 906, section on Sampling).

**5.1.11 Purchaser Inspection** — If the purchaser wishes to witness the tests or inspection of material at the place of manufacture, the purchase order must so state indicating which tests or inspections are to be witnessed (see Specification B 906, section on Inspection).

## 6. Chemical Composition

**6.1** The material shall conform to the requirements as to chemical composition prescribed in Table 2.

**6.2** If a product (check) analysis is performed by the purchaser, the material shall conform to the product (check) analysis variations prescribed in Specification B 906.

## 7. Mechanical and Other Requirements

**7.1 Mechanical Properties** — The material shall conform to the requirements for mechanical properties prescribed in Table 3.

**7.2 Deep-Drawing and Spinning Quality Sheet and Strip** — The material shall conform to the requirements for grain size and hardness properties prescribed in Table 4.

**7.2.1** The mechanical properties of Table 3 do not apply to deep-drawing and spinning quality sheet and strip.

## 8. Dimensions and Permissible Variations

### 8.1 Weight:

**8.1.1** For calculations of mass or weight a density of 0.319 lb/in.<sup>3</sup> (8.83 g/cm<sup>3</sup>) shall be used.

### 8.2 Thickness:

**8.2.1 Plate** — For plate up to 2 in. (50.8 mm) inclusive, in thickness, the permissible variation, under the specified thickness and permissible excess in overweight shall not exceed the amounts prescribed in Specification B 906, see Permissible Variations in Thickness and Overweight of Rectangular Plates Table.

**8.2.2 Plate** — For plate over 2 in. (50.8 mm) in thickness, the permissible variations over the specified thickness shall not exceed the amounts prescribed in Specification B 906, see Permissible Variations in Thickness for Rectangular Plates Over 2 in. (51 mm) in Thickness Table.

**8.2.3 Sheet and Strip** — The permissible variations in thickness of sheet and strip shall be prescribed in Specification B 906, see Permissible Variations in Thickness of Sheet and Strip Table. The thickness of strip and sheet shall be measured with the micrometer spindle  $\frac{3}{8}$  in. (9.5 mm) or more from either edge for material 1 in. (25.4 mm) or over in width and at any place on the strip under 1 in. in width.

### 8.3 Width or Diameter:

**8.3.1 Plate** — The permissible variations in width of rectangular plates and diameter of circular plates shall be as prescribed in Specification B 906, see Permissible Variations in Width of Sheared, Plasma Torch-Cut, and Abrasive-Cut Rectangular Plate Table and Permissible Variations in Diameter for Circular Plates Table.

**8.3.2 Sheet and Strip** — The permissible variations in width for sheet and strip shall be as prescribed in Specification B 906, see Permissible Variations in Width of Sheet and Strip Table.

### 8.4 Length:

**8.4.1** Sheet and strip of all sizes may be ordered to cut lengths in which case, a variation of  $\frac{1}{8}$  in. (3.2 mm) over the specified length shall be permitted.

**8.4.2** Permissible variations in length of rectangular plate shall be as prescribed in Specification B 906, see Permissible Variations in Length of Sheared, Plasma Torch-Cut, and Abrasive-Cut Rectangular Plate Table.

TABLE 3  
MECHANICAL PROPERTIES FOR PLATE, SHEET, AND STRIP (ALL THICKNESSES AND SIZES UNLESS OTHERWISE INDICATED)

Condition (Temper)	Tensile Strength, min, psi (MPa)	Yield Strength <sup>A</sup> (0.2% offset), min, psi (MPa)	Elongation in 2 in. or 50 mm, or 4D, min, %	Rockwell Hardness (B Scale) <sup>B,C</sup>
Hot-Rolled Plate				
Annealed	70 000 (485)	28 000 (195)	35	...
As-rolled <sup>D,E</sup>	75 000 (515)	40 000 (275)	25	...
Hot-Rolled Sheet				
Annealed	70 000 (485)	28 000 (195)	35	...
Cold-Rolled Sheet				
Annealed	70 000 to 85 000 (485 to 585)	28 000 (195)	35	...
Quarter-hard	...	...	...	73 to 83
Half-hard	...	...	...	82 to 90
Hard	100 000 (690)	90 000 (620)	2	...
Cold-Rolled Strip				
Annealed	70 000 to 85 000 (485 to 585) <sup>F</sup>	28 000 (195)	35 <sup>F</sup>	...
Skin hard	...	...	...	68 to 73
Quarter-hard	...	...	...	73 to 83
Half-hard	...	...	...	82 to 90
Three-quarter-hard	...	...	...	89 to 94
Hard	100 000 (690) <sup>F</sup>	90 000 (620)	2 <sup>F</sup>	...
Spring temper	...	...	...	98 min

<sup>A</sup> Yield strength requirements do not apply to material under 0.020 in. (0.51 mm) in thickness.

<sup>B</sup> For Rockwell or equivalent hardness conversions see Hardness Conversion Tables E 140.

<sup>C</sup> Caution should be observed in using the Rockwell test on thin material, as the results may be affected by specimen thickness. For thicknesses under 0.050 in. (1.3 mm), the use of the Rockwell superficial or the Vickers hardness test is suggested.

<sup>D</sup> As-rolled plate may be given a stress-relieving heat treatment subsequent to final rolling.

<sup>E</sup> As-rolled plate specified "suitable for hot forming" shall be furnished from heats of known good hot-malleability characteristics (see X1.2.2). There are no applicable tensile or hardness requirements for such material.

<sup>F</sup> Not applicable for thickness under 0.010 in. (0.25 mm).

## 8.5 Straightness:

**8.5.1** The edgewise curvature (depth of chord) of flat sheet, strip, and plate shall not exceed 0.05 in. multiplied by the length in feet (0.04 mm multiplied by the length in centimetres).

**8.5.2** Straightness for coiled material is subject to agreement between the manufacturer and the purchaser.

## 8.6 Edges:

**8.6.1** When finished edges of strip are specified in the contract or purchase order, the following descriptions shall apply:

**8.6.1.1** Square-edge strip shall be supplied with finished edges, with sharp, square corners, and without bevel or rounding.

**8.6.1.2** Round-edge strip shall be supplied with finished edges, semicircular in form, and the diameter of the circle forming the edge being equal to the strip thickness.

**8.6.1.3** When no description of any required form of strip edge is given, it shall be understood that edges such as those resulting from slitting or shearing will be acceptable.

**8.6.1.4** Sheet shall have sheared or slit edges.

**8.6.1.5** Plate shall have sheared or cut (machined, abrasive-cut, powder-cut, or inert-arc-cut) edges, as specified.

**8.7 Squareness (Sheet)** — For sheets of all thicknesses, the angle between adjacent sides shall be  $90 \pm 0.15^\circ$  ( $\frac{1}{16}$  in. in 24 in.) (1.6 mm in 610 mm).

## 8.8 Flatness:

**8.8.1** There shall be no flatness requirements for "deep drawing quality," "spinning quality," or "as-rolled," sheet and strip (see X1.4).

**8.8.2** Standard flatness tolerances for plate shall conform to the requirements prescribed in Table 5. "Specially

**TABLE 4**  
**GRAIN SIZE AND HARDNESS FOR COLD-ROLLED, DEEP-DRAWING, AND SPINNING QUALITY SHEET AND STRIP**

Thickness, in. (mm)	Calculated Diameter of Average Grain Section, max		Corresponding ASTM Micro-Grain Size No.	Rockwell B <sup>A,B</sup> Hardness, max
	mm	in.		
Sheet (56 in. (1420 mm) Wide and Under)				
0.050 (1.3) and under	0.075	0.0030	4.5	76
Over 0.050 to 0.250 (1.3 to 6.4), incl	0.110	0.0043	3.5	76
Strip (12 in. (305 mm) Wide and Under) <sup>C</sup>				
0.005 <sup>D</sup> to 0.015 (0.13 to 0.38), incl	0.022	0.0009	8 <sup>E</sup>	76 <sup>E</sup>
Over 0.015 to 0.024 (0.38 to 0.61), incl	0.060	0.0024	5.5	76
Over 0.024 to 0.125 (0.61 to 3.2), incl	0.075	0.0030	4.5	76

<sup>A</sup> For Rockwell or equivalent hardness conversions see Hardness Conversion Tables E 140.

<sup>B</sup> Caution should be observed in using the Rockwell test on thin material as the results may be affected by specimen thickness. For thicknesses under 0.050 in. (1.3 mm), the use of the Rockwell superficial or the Vickers hardness test is suggested.

<sup>C</sup> Sheet requirements in Table 4 apply to strip thicknesses over 0.125 in. (3.2 mm), and for all thicknesses of strip over 12 in. (305 mm) in width.

<sup>D</sup> For ductility evaluations for strip under 0.005 in. (0.13 mm) in thickness, the spring-back test such as described in Test Method F 155 is often used and the manufacturer should be consulted.

<sup>E</sup> Accurate grain size and hardness determinations are difficult to make on strip under 0.005 in. (0.13 mm) in thickness and are not recommended.

**TABLE 5**  
**PERMISSIBLE VARIATIONS FROM FLATNESS OF RECTANGULAR, CIRCULAR, AND SKETCH PLATES**

Specified Thickness	Permissible Variations from a Flat Surface for Thickness and Widths Given, in. (mm)								
	To 48 (1220), excl	48 to 60 (1220 to 1520), excl	60 to 72 (1520 to 1830), excl	72 to 84 (1830 to 2130), excl	84 to 96 (2130 to 2440), excl	96 to 108 (2440 to 2740), excl	108 to 120 (2740 to 3050), excl	120 to 144 (3050 to 3660), excl	144 (3660) and over
Inches									
3/16 to 1/4, excl	3/4	1 1/16	1 1/4	1 3/8	1 5/8	1 5/8	...	...	...
1/4 to 3/8, excl	1 1/16	3/4	15/16	1 1/8	1 3/8	1 7/16	1 9/16	1 7/8	...
3/8 to 1/2, excl	1/2	9/16	11/16	3/4	15/16	1 1/8	1 1/4	1 7/16	1 3/4
1/2 to 3/4, excl	1/2	9/16	5/8	13/16	1 1/8	1 1/8	1 1/8	1 3/8	1 3/8
3/4 to 1, excl	1/2	9/16	5/8	5/8	3/4	13/16	15/16	1	1 1/8
1 to 2, excl	1/2	9/16	9/16	9/16	11/16	11/16	11/16	3/4	1
2 to 4, incl	1/4	5/16	3/8	7/16	1/2	9/16	5/8	3/4	7/8
Millimetres									
4.8 to 6.4, excl	19.0	27.0	31.7	34.9	41.3	41.3	...	...	...
6.4 to 9.5, excl	17.5	19.0	23.8	28.6	35.0	36.5	39.7	47.6	...
9.5 to 12.7, excl	12.7	14.3	17.5	19.0	23.8	28.6	31.7	35.0	44.4
12.7 to 19.0, excl	12.7	14.3	15.9	15.9	20.6	28.6	28.6	28.6	34.9
19.0 to 25.4, excl	12.7	14.3	15.9	15.9	19.0	20.6	23.8	25.4	28.6
25.4 to 50.8, excl	12.7	14.3	14.3	14.3	17.5	17.5	17.5	19.0	25.4
50.8 to 101.6, incl	6.4	7.9	9.5	11.1	12.7	14.3	15.9	19.0	22.2

NOTE 1 — Permissible variations apply to plates up to 12 ft (366 cm) in length, or to any 12 ft or longer plates.

NOTE 2 — If the longer dimension is under 36 in. (914 mm), the permissible variation is not greater than 1/4 in. (6.4 mm).

NOTE 3 — The shorter dimension specified is considered the width, and the permissible variation in flatness across the width does not exceed the tubular amount of that dimension.

NOTE 4 — The maximum deviation from a flat surface does not customarily exceed the tabular tolerance for the longer dimension specified.

flattened” plate when so specified, shall have permissible variations in flatness as agreed upon between the manufacturer and the purchaser.

## 9. Workmanship, Finish, and Appearance

**9.1** The material shall be uniform in quality and temper, smooth, commercially straight or flat, and free of injurious imperfections.

**9.2** *Sheet, Strip, and Plate* — Sheet, strip, and plate supplied in the conditions and finishes as listed in the appendix may be ground or machined to remove surface imperfections, provided such removal does not reduce the material below the minimum specified dimensions. Surface eliminated depressions shall be faired smoothly into the surrounding material. The removal of a surface imperfection shall be verified by the method originally used to detect the imperfection.

## 10. Product Marking

**10.1** Each plate, sheet, or strip shall be marked on one face with the specification number, alloy, condition (temper), heat number, manufacturer’s identification, and size. The markings shall not have a deleterious effect on the material or its performance and shall be sufficiently stable to withstand normal handling.

**10.2** When applicable, each bundle or shipping container shall be marked with the name of the material, condition (temper), this specification number, alloy, size, consignor and consignee address, contract or order number, and such other information as may be defined in the contract or order.

## 11. Keywords

**11.1** N04400; plate; sheet; strip

ASME BPVC Section II part B) 2025  
ASME BPVC.II.B (ASME BPVC Section II part B) 2025  
ASMENORMDOC.COM : Click to view the full PDF of ASME BPVC.II.B (ASME BPVC Section II part B) 2025

## SUPPLEMENTARY REQUIREMENTS

The following supplementary requirements shall apply only when specified by the purchaser in the inquiry, contract, or order, for agencies of the U.S. Government.

### S1. Referenced Documents

**S1.1** The following documents of the issue in effect on date of material purchased form a part of this specification to the extent referenced herein. Federal Standard No. 102, No. 123, No. 182, and Military Standard MIL-STD-129.

### S2. Chemical Composition

**S2.1** The material shall conform to the composition limits specified in Table 2 except as specified in Table S2.1.

### S3. Mechanical Properties

**S3.1** Mechanical property requirements for quarter hard cold-rolled strip  $\frac{1}{4}$  in. thick and less shall be as specified in Table S3.1.

### S4. Nondestructive Tests

**S4.1** When specified by the purchaser, each piece of each lot shall be inspected. The purchaser shall specify if one or both tests are required.

TABLE S2.1  
CHEMICAL REQUIREMENTS

Element	Composition Limits, %
Carbon	0.2 max.
Sulfur	0.015 max.
Aluminum	0.5 max.
Lead	0.006 max.
Tin	0.006 max.
Zinc	0.02 max.
Phosphorous	0.02 max.

TABLE S3.1  
MECHANICAL PROPERTIES FOR QUARTER-HARD  
COLD ROLLED STRIP

Tensile Strength, min, psi (MPa)	78 000–85 000 (538–586)
Yield Strength, min, psi (MPa) (0.2% offset)	45,000 (310)
Elongation in 2 in., 50 mm, or 4D, min, %	20

### S4.2 Ultrasonic Tests:

#### S4.2.1 General Requirements:

**S4.2.1.1** Ultrasonic testing shall be performed in accordance with MIL-STD-271 as modified by the requirements specified herein.

**S4.2.1.2** Acoustic compatibility between the production material and the calibration standard material shall be within 75%. If the acoustic compatibility is within 25%, no gain compensation is required for the examination. If acoustic compatibility difference is between 25% and 75%, a change in the gain or dB controls shall be accomplished to compensate for the differences in acoustic compatibility. This method cannot be used if the ultrasonic noise level exceeds 50% of the rejection value.

#### S4.2.2 Calibration:

**S4.2.2.1 Longitudinal Wave** — The longitudinal wave test shall be calibrated on a flat-bottomed reference hole of a given diameter in accordance with Table S4.1 for specified material thickness drilled either into the piece to be tested or into a separate defect-free specimen of the same size (within  $\pm \frac{1}{8}$  in. (3.18 mm)), shape, material, and condition, or acoustically similar material. Holes are to be drilled to midsection and the bottom of the hole shall be parallel to the entrant surface. The ultrasonic test instrument shall be adjusted so that the response from the reference hole shall not be less than 25% and not more than 75% of screen height.

**S4.2.2.2 Recalibration** — During quality conformance inspection, any realignment of the search unit that will cause a decrease in the calibrated sensitivity and resolution, or both, or any change in search unit, couplant, instrument settings, or scanning speed from that used for calibration shall require recalibration. Recalibration shall be performed at least once per 8 h shift.

**S4.2.3 Procedure** — Paragraph S4.2.3.1 describes the requirements for plate. Sheet and strip shall be excluded from these requirements.

TABLE S4.1  
ULTRASONIC TESTING REFERENCE HOLE FOR PLATE

Material Thickness, in. (mm)	Hole Diameter, in. (mm)
Up to and including 4 (102)	$\frac{1}{4}$ (6.4)
Over 4 (102)	$\frac{1}{2}$ (12.7)

**S4.2.3.1 Plate** — Plate shall be inspected by the longitudinal wave technique using the contact or immersion method. For contact, the scanning shall be on a 24 in. grid and one diagonal in each grid. For immersion, the scanning shall be continuous on a 12 in. grid. For either method, the search shall be expanded to determine the full extent of any rejectable indication if the material is to be offered on a waiver basis.

**S4.2.4 Acceptance Criteria:**

**S4.2.4.1 Longitudinal Wave** — Any material that produces indications equal to or larger than the response from the reference hole, or that produces a complete loss of back reflection shall be rejected. Material shall be tested using a square, rectangular, or circular transducer having an effective area of one square inch or less, but no dimension shall be smaller than the diameter of the reference hole. In the event of disagreement on the degree of back reflection loss, it shall be determined by the contact method using a 1 to 1½ in. (25.4 to 28.6 mm) diameter transducer or one whose area falls within this range.

**S4.2.4.2 Reference Notch Removal** — If reference notches or flat-bottomed holes are made in the material to be tested, they shall be so located that their subsequent removal will not impair the suitability of the material for its intended use.

**S4.3 Liquid Penetrant Inspection:**

**S4.3.1 Procedure** — Liquid penetrant inspection shall be in accordance with MIL-STD-271.

**S4.3.2 Surface Requirements** — The surface produced by hot working is not suitable for liquid penetrant testing. Therefore, liquid penetrant testing will not be applicable to products ordered with a hot finished surface.

**S4.3.3 Acceptance Criteria** — Linear defects revealed by liquid penetrant inspection shall be explored by grinding or other suitable means. Depth of defects shall not exceed the dimensional tolerance of the material.

**S5. Quality Assurance**

**S5.1 Responsibility for Inspection** — Unless otherwise specified in the contract or purchase order, the manufacturer is responsible for the performance of all inspection and test requirements specified. Except as otherwise specified in the contract or purchase order, the manufacturer may use his own or any other suitable facilities for the performance of the inspection and test requirements unless disapproved by the purchaser at the time the order is placed. The purchaser shall have the right to perform any of the inspections or tests set forth when such inspections and tests are deemed necessary to assure that the material conforms to prescribed requirements.

**S6. Identification Marking**

**S6.1** All material shall be properly marked for identification in accordance with Fed. Std. No. 182 except that the ASTM specification number and the alloy number shall be used.

**S7. Preparation for Delivery**

**S7.1 Preservation, Packaging, Packing:**

**S7.1.1 Military Agencies** — The material shall be separated by size, composition, grade, or class and shall be preserved and packaged, Level A or C, or packed, Level A, B, or C as specified in the contract or purchase order.

**S7.1.2 Civil Agencies** — The requirements of Fed. Std. No. 102 shall be referenced for definitions of the various levels of packaging protection.

**S7.2 Marking:**

**S7.2.1 Military Agencies** — In addition to any special marking required by the contract or purchase order, marking for shipment shall be in accordance with MIL-STD-129.

**S7.2.2 Civil Agencies** — In addition to any special marking required by the contract or purchase order, marking for shipment shall be in accordance with Fed. Std. No. 123.

## APPENDIX

## (Nonmandatory Information)

**X1. CONDITIONS AND FINISHES****X1.1 Scope**

**X1.1.1** This appendix lists the conditions and finishes in which plate, sheet, and strip are normally supplied. These are subject to change and the manufacturer should be consulted for the latest information available.

**X1.2 Plate, Hot-Rolled**

**X1.2.1 Annealed** — Soft with an oxide surface and suitable for heavy cold forming. Available with a descaled surface, when so specified.

**X1.2.2 As-Rolled** — With an oxide surface. Available with a descaled surface, when so specified. Suitable for flat work, mild forming, or tube sheets. When intended for tube sheets, specify that plates are to be specially flattened. When intended for hot forming, this should be indicated on the purchase order so that the manufacturer may select appropriate material.

**X1.3 Plate, Cold-Rolled**

**X1.3.1 Annealed** — Soft with an oxide surface; available with a descaled surface when so specified.

**X1.4 Sheet, Hot-Rolled**

**X1.4.1 Annealed, and Pickled** — Soft with a pickled matte finish. Properties similar to X1.5.1 but with broader thickness tolerances. Not suggested for applications where the finish of a cold-rolled sheet is considered essential, or for deep drawing or spinning.

**X1.5 Sheet and Strip, Cold-Rolled**

**X1.5.1 Annealed** — Soft with a pickled or bright annealed finish.

**X1.5.2 Deep-Drawing or Spinning Quality** — Similar to X1.5.1, except furnished to controlled hardness and grain size and lightly leveled.

**X1.5.3 Skin Hard** — Similar to X1.5.1 but given a light cold reduction to hardness range shown in Table 3.

**X1.5.4 Quarter-Hard** — Cold rolled to the hardness range indicated in Table 3, bright finish. Out-of-flatness must be expected and will vary with temper and thickness.

**X1.5.5 Half-Hard** — Cold rolled to the hardness range indicated in Table 3, bright finish. Out-of-flatness must be expected and will vary with temper and thickness.

**X1.5.6 Three-Quarter Hard** — Cold rolled to the hardness range indicated in Table 3, bright finish. Out-of-flatness must be expected and will vary with temper and thickness.

**X1.5.7 Hard** — Cold rolled to the tensile requirements indicated in Table 3, bright finish. Out-of-flatness must be expected and will vary with temper and thickness.

**X1.5.8 Spring Temper** — Cold rolled to the minimum hardness indicated in Table 3, bright finish. Out-of-flatness must be expected and will vary with temper and thickness.

ASMENORMDOC.COM : Click to view the full PDF of ASME BPVC.II.B (ASME BPVC Section II part B) 2025

INTENTIONALLY LEFT BLANK

## SPECIFICATION FOR SEAMLESS BRASS TUBE



**SB-135/SB-135M**

(Identical with ASTM Specification B135/B135M-17 except for revisions to para. 8.2 and Note 1. Mechanical property requirements of Note 1 are mandatory.)

# Specification for Seamless Brass Tube

## 1. Scope

1.1 This specification covers seamless round and rectangular including square copper alloy tube in straight lengths. Ten alloys are specified having the following nominal compositions:

Copper Alloy UNS No.	Previously Used Designation <sup>A</sup>	Nominal Composition, %			
		Copper	Zinc	Lead	Tin
C22000	7	90.0	10.0	...	...
C23000	1	85.0	15.0	...	...
C26000	2	70.0	30.0	...	...
C27000	9	65.0	35.0	...	...
C27200	8	63.0	37.0	...	...
C27400	...	62.5	37.5	...	...
C28000	5	60.0	40.0	...	...
C33000	3	66.0	33.5	0.5	...
C33200	4	66.0	32.4	1.6	...
C37000	6	60.0	39.0	1.0	...
C44300	...	71.5	27.5	...	1.00

<sup>A</sup> Alloy Designations of Specification B135 – 63, which was published in the 1966 Book of ASTM Standards, Part 5.

1.2 The values stated in either SI units or inch-pound units are to be regarded separately as standard. The values stated in each system may not be exact equivalents; therefore, each system shall be used independently of the other. Combining values from the two systems may result in non-conformance with the standard.

1.3 **Warning**—Mercury has been designated by many regulatory agencies as a hazardous substance that can cause serious medical issues. Mercury, or its vapor, has been demonstrated to be hazardous to health and corrosive to materials. Caution should be taken when handling mercury and mercury containing products. See the applicable product Safety Data Sheet (SDS) for additional information. Users should be aware that

selling mercury and/or mercury containing products into your state or country may be prohibited by law. (See 10.1.)

1.4 *This standard does not purport to address all of the safety concerns, if any, associated with its use. It is the responsibility of the user of this standard to establish appropriate safety, health, and environmental practices and determine the applicability of regulatory limitations prior to use.*

1.5 *This international standard was developed in accordance with internationally recognized principles on standardization established in the Decision on Principles for the Development of International Standards, Guides and Recommendations issued by the World Trade Organization Technical Barriers to Trade (TBT) Committee.*

## 2. Referenced Documents

### 2.1 ASTM Standards:

- B153 Test Method for Expansion (Pin Test) of Copper and Copper-Alloy Pipe and Tubing
- B154 Test Method for Mercurous Nitrate Test for Copper Alloys
- B251/B251M Specification for General Requirements for Wrought Seamless Copper and Copper-Alloy Tube
- B601 Classification for Temper Designations for Copper and Copper Alloys—Wrought and Cast
- B846 Terminology for Copper and Copper Alloys
- B858 Test Method for Ammonia Vapor Test for Determining Susceptibility to Stress Corrosion Cracking in Copper Alloys
- B968/B968M Test Method for Flattening of Copper and Copper-Alloy Pipe and Tube
- E243 Practice for Electromagnetic (Eddy Current) Examination of Copper and Copper-Alloy Tubes
- E527 Practice for Numbering Metals and Alloys in the Unified Numbering System (UNS)

## 3. Terminology

3.1 For terms related to copper and copper alloys, refer to Terminology B846.

#### 4. Ordering Information

4.1 Orders for material under the specification shall include the following information:

- 4.1.1 Alloy (Section 1),
- 4.1.2 Temper (Section 7),
- 4.1.3 Whether tension tests are required (for drawn tempers only (see 8.1)),
- 4.1.4 Dimensions: diameter or distance between parallel surfaces and wall thickness (see 11.2 and 11.3),
- 4.1.5 Length (see 12.4),
- 4.1.6 Stress Corrosion Resistance Testing, if required (Section 10),
- 4.1.7 Total length of each size,
- 4.1.8 Hydrostatic pressure test, when specified, and
- 4.1.9 Pneumatic test, when specified.

#### 5. General Requirements

5.1 Material furnished under this specification shall conform to the applicable requirements of the current edition of Specification B251/B251M.

5.2 The following sections of Specification B251/B251M constitute a part of this specification:

- 5.2.1 Terminology
- 5.2.2 Materials and Manufacture
- 5.2.3 Dimensions and Permissible Variations
- 5.2.4 Sampling
- 5.2.5 Number of Tests and Retests
- 5.2.6 Specimen Preparation
- 5.2.7 Certification
- 5.2.8 Test Reports

5.3 In addition, when a section with a title identical to that referenced in 5.1, above, appears in this specification, it contains additional requirements which supplement those appearing in Specification B251/B251M.

#### 6. Chemical Composition

6.1 The material shall conform to the chemical requirements specified in Table 1.

6.2 These specification limits do not preclude the presence of other elements. Limits for unnamed elements are to be established by agreement between manufacturer or supplier and purchaser.

6.2.1 For alloys in which zinc is listed as “remainder,” either copper or zinc may be taken as the difference between the sum of results of all other elements determined and 100 %. When all elements in Table 1 are determined, the sum of the results shall be as shown in the following table:

Copper Alloy UNS No.	Copper Plus Named Elements, % min
C22000	99.8
C23000	99.8
C26000	99.7
C27000	99.7
C27200	99.7
C27400	99.7
C28000	99.7
C33000	99.6
C33200	99.6
C37000	99.6
C44300	99.6

#### 7. Temper

7.1 *Drawn Tempers, H*—The tempers of drawn tube shall be designated as light-drawn (H55), drawn (H58), and hard-drawn (H80) (see Tables 2 and 3). Light-drawn (bending) temper is used only when a tube of some stiffness but yet capable of being bent is needed. Drawn temper is for general purposes and is most commonly used where there is no specific requirement for high strength on the one hand or for bending qualities on the other. Hard-drawn temper is used only where there is need for a tube as strong as is commercially feasible for the sizes indicated. For any combination of diameter and wall thickness not covered under hard-drawn temper, the values given for drawn temper shall be used. Rectangular including square tubes shall normally be supplied only in drawn (general-purpose) temper. When there is a need for light-drawn or hard-drawn tempers these are to be supplied as agreed upon between the manufacturer and the purchaser.

7.2 *Annealed Tempers, O*—The tempers of annealed tube shall be designated as light anneal (O50) and soft anneal (O60) (Tables 4 and 5).

NOTE 1—Tube of Copper Alloy UNS No. C23000, shall have in the annealed condition a minimum tensile strength of 40 ksi [275 MPa] and a minimum yield strength of 12 ksi [80 MPa] at 0.5 % extension under load.

TABLE 1 Chemical Requirements

Copper Alloy UNS No.	Composition, %					
	Copper	Lead	Arsenic	Tin	Iron, max	Zinc
C22000	89.0–91.0	0.05 max	...	...	0.05	remainder
C23000	84.0–86.0	0.05 max	...	...	0.05	remainder
C26000	68.5–71.5	0.07 max	...	...	0.05	remainder
C27000	63.0–68.5	0.09 max	...	...	0.07	remainder
C27200	62.0–65.0	0.07 max	...	...	0.07	remainder
C27400	61.0–64.0	0.09 max	...	...	0.05	remainder
C28000	59.0–63.0	0.09 max	...	...	0.07	remainder
C33000	65.0–68.0	0.25 <sup>A</sup> –0.7	...	...	0.07	remainder
C33200	65.0–68.0	1.5–2.5	...	...	0.07	remainder
C37000	59.0–62.0	0.9–1.4	...	...	0.15	remainder
C44300	70.0–73.0	0.07 max	0.02–0.06	0.9–1.2	0.06	remainder

<sup>A</sup> In the case of Copper Alloy UNS No. C33000 on tube sizes greater than 5 in. in outside diameter, or distance between outside parallel surfaces, the lead content shall be 0.7 % maximum, no minimum is specified.

TABLE 2 Mechanical Property Requirements of Drawn Temper Tube—Inch-Pound Values

Copper Alloy UNS No.	Temper Designation <sup>A</sup>		Outside Diameter, in. or Major Distance Between Outside Parallel Surfaces, in.	Wall Thickness, in.	Tensile Strength ksi <sup>B</sup>	Rockwell Hardness <sup>C</sup> 30T
	Standard	Former				
C22000	H58	drawn (general purpose)	all	all	40 min	38 min
C22000	H80	hard drawn <sup>D</sup>	up to 1, incl	0.020 to 0.120, incl	52 min	55 min
C22000	H80	hard drawn <sup>D</sup>	over 1 to 2, incl	0.035 to 0.180, incl	52 min	55 min
C22000	H80	hard drawn <sup>D</sup>	over 2 to 4, incl	0.060 to 0.250, incl	52 min	55 min
C23000	H55	light drawn <sup>D</sup>	all	all	44–58	43–75
C23000	H58	drawn (general purpose)	all	all	44 min	43 min
C23000	H80	hard drawn <sup>D</sup>	up to 1, incl	0.020 to 0.120, incl	57 min	65 min
C23000	H80	hard drawn <sup>D</sup>	over 1 to 2, incl	0.035 to 0.180, incl	57 min	65 min
C23000	H80	hard drawn <sup>D</sup>	over 2 to 4, incl	0.0605 to 0.250, incl	57 min	65 min
C26000, C27000, C27200, C27400, C33000, and C33200	H58	drawn (general purpose)	all	all	54 min	53 min
C26000, C27000, C27200, C27400, C33000, and C33200	H80	hard drawn <sup>D</sup>	up to 1, incl	0.020 to 0.120, incl	66 min	70 min
C26000, C27000, C27200, C27400, C33000, and C33200	H80	hard drawn <sup>D</sup>	over 1 to 2, incl	0.035 to 0.180, incl	66 min	70 min
C26000, C27000, C27200, C27400, C33000, and C33200	H80	hard drawn <sup>D</sup>	over 2 to 4, incl	0.060 to 0.250, incl	66 min	70 min
C28000 and C37000	H58	drawn (general purpose)	all	all	54 min	55 min
C44300	H58	drawn (general purpose)	all	all	54 min	53 min
C44300	H80	hard drawn <sup>D</sup>	all	all	66 min	70 min

<sup>A</sup> Standard designations defined in Classification B601.

<sup>B</sup> ksi = 1000 psi.

<sup>C</sup> Rockwell hardness values shall apply only to tubes having a wall thickness of 0.012 in. or over and to round tubes having an inside diameter of 5/16 in. or over and to rectangular including square tubes having an inside major distance between parallel surfaces of 3/16 in. or over. Rockwell hardness shall be made on the inside surface of the tube. When suitable equipment is not available for determining the specified Rockwell hardness, other Rockwell scales and values shall be specified subject to agreement between the manufacturer and the purchaser.

<sup>D</sup> Light-drawn and hard-drawn tempers are available in round-tube only.

8. Mechanical Properties

8.1 *Drawn Temper*—Tube shall conform to the mechanical properties prescribed in Tables 2 and 3. Tension tests are required for tubes with a wall thickness under 0.020 in. [50 mm] and for round tubes having an inside diameter under 5/16 in. [8.0 mm] and for rectangular including square tubes having a major distance between inside parallel surfaces under 3/16 in. [5.0 mm]. The tension test for other sizes of tubes need not be made except when indicated by the purchaser at the time of placing the order. A convenient method of indicating that the tension test is required is to specify that “Test procedure ‘T’ is required” (see 4.1.3). When agreement on the Rockwell hardness tests cannot be reached, the tensile strength requirements of Table 2 shall be the basis for acceptance or rejection.

8.2 *Annealed Temper*—The mechanical property requirements of Copper Alloy UNS No. C23000 tube shall be those given in 7-2, Note 1.

9. Expansion Test for Round Tube

9.1 Tube ordered in the annealed (O) condition, selected for test, shall be capable of withstanding in accordance with Test Method B153 an expansion of the outside diameter in the following amount:

Outside Diameter, in.	Expansion of Outside Diameter, %
3/4 and under	20
Over 3/4	15

The expanded tube shall show no cracking or rupture visible to the unaided eye. Tube ordered in the drawn (H) condition is not subject to this test.

NOTE 2—The term “unaided eye,” as used herein, permits the use of corrective spectacles necessary to obtain normal vision.

9.2 As an alternative to the expansion test for tube over 4 in. [100 mm] in diameter in the annealed condition shall be Test Method B968/B968M.

9.3 Drawn temper tube shall not be required to withstand these tests.

10. Mercurous Nitrate Test

10.1 **Warning**—Mercury is a definite health hazard. Use equipment for the detection and removal of mercury vapor. Wear rubber gloves when conducting the test.

10.2 When specifically required, test specimens 6 in. [150 mm] in length of both annealed and drawn tempers shall withstand, after proper cleaning, an immersion for 30 min

TABLE 3 Mechanical Property Requirements of Drawn Temper Tube—SI Values

Copper Alloy UNS No.	Temper Designation <sup>A</sup>		Outside Diameter, mm or Major Distance Between Outside Parallel Surfaces, mm	Wall Thickness, mm	Tensile Strength, MPa	Rockwell Hardness <sup>B</sup> 30T
	Standard	Former				
C22000	H58	drawn (general purpose)	all	all	275 min	38 min
C22000	H80	hard drawn <sup>C</sup>	up to 25, incl	0.050 to 3.0, incl	360 min	55 min
C22000	H80	hard drawn <sup>C</sup>	over 25 to 40, incl	0.090 to 5.50, incl	360 min	55 min
C22000	H80	hard drawn <sup>C</sup>	over 50 to 100, incl	1.5 to 6.0, incl	360 min	55 min
C23000	H55	light drawn <sup>C</sup>	all	all	305–400	43–75
C23000	H58	drawn (general purpose)	all	all	305 min	43 min
C23000	H80	hard drawn <sup>C</sup>	up to 25, incl	0.050 to 3.0, incl	395 min	65 min
C23000	H80	hard drawn <sup>C</sup>	over 25 to 50, incl	0.090 to 5.0, incl	395 min	65 min
C23000	H80	hard drawn <sup>C</sup>	over 50 to 100, incl	1.5 to 6.0, incl	395 min	65 min
C26000, C27000, C27200, C27400, C33000, and C33200	H58	drawn (general purpose)	all	all	370 min	53 mm
C26000, C27000, C27200, C27400, C33000, and C33200	H80	hard drawn <sup>C</sup>	up to 25, incl	0.050 to 3.0, incl	455 min	70 min
C26000, C27000, C27200, C27400, C33000, and C33200	H80	hard drawn <sup>C</sup>	over 25 to 50, incl	0.090 to 5.0, incl	455 min	70 min
C26000, C27000, C27200, C27400, C33000, and C33200	H80	hard drawn <sup>C</sup>	over 50 to 100, incl	1.5 to 6.0, incl	455 min	70 min
C28000 and C37000	H58	drawn (general purpose)	all	all	370 min	55 min
C44300	H58	drawn (general purpose)	all	all	370 min	53 min
C44300	H80	hard drawn <sup>C</sup>	all	all	455 min	70 min

<sup>A</sup> Standard designations defined in Classification B601.

<sup>B</sup> Rockwell hardness values shall apply only to tubes having a wall thickness of 0.30 mm or over and to round tubes having an inside diameter of 8.0 mm or over and to rectangular including square tubes having an inside major distance between parallel surfaces of 5.0 mm or over. Rockwell hardness shall be made on the inside surface of the tube. When suitable equipment is not available for determining the specified Rockwell hardness, other Rockwell scales and values shall be specified.

<sup>C</sup> Light-drawn and hard-drawn tempers are available in round tube only.

without cracking in the standard mercurous nitrate solution prescribed in Test Method B154. Immediately after removal from the solution, the specimen shall be wiped free of excess mercury and examined for cracks.

## 11. Nondestructive Testing

11.1 Unless nondestructive testing has been waived, tubes shall be subjected to a nondestructive test. The manufacturer shall select the nondestructive test that is most suitable for the tube size and the application.

11.1.1 Eddy-current testing is the standard nondestructive test, and all tubes of appropriate size shall be eddy-current tested in accordance with 11.2.

11.1.2 Tubes that are not of a size suitable for eddy-current test capabilities shall be tested by the hydrostatic test as described in 11.3.1, or by the pneumatic test as described in 11.3.2.

11.2 *Eddy-Current Test*—Each tube up to 3½ in. [79 mm] in outside diameter shall be subjected to an eddy-current test. Testing shall follow the procedure of Practice E243, except the determination of “end effect” is not required. Tubes shall be passed through an eddy-current test unit adjusted to provide information on the suitability of the tube for the intended application.

11.2.1 Notch-depth standards rounded to the nearest 0.001 in. [0.03 mm] shall be 22 % of the nominal wall thickness. The notch-depth tolerance shall be ±0.0005 in.

[±0.01 mm]. Alternatively, if the manufacturer uses speed-insensitive eddy-current units that are equipped so that a fraction of the maximum unbalance signal is able to be selected, the following percent maximum unbalance signals shall be used.

Standard Tube Size, in. [mm]	Maximum Percent Unbalance Signal Magnitude
Up to and including ⅜ [12 mm]	0.2
½ to 2 incl [15 to 54 mm incl]	0.3
Over 2 to 3 incl [54 to 79 mm incl]	0.4

11.2.2 Tubes that do not actuate the signalling device of the eddy-current testers shall be considered as conforming to the requirements of this test. If reexamined or retested, tubes with signals that are found to have been caused by minor mechanical damage, soil, or moisture, shall not be cause for rejection of the tubes provided the tube dimensions are still within prescribed limits and the tube is suitable for its intended application.

11.3 A pressure test shall be specified for tube sizes over 3½ in. [79 mm] in outside diameter or tube of dimensions beyond the capabilities of the eddy-current test apparatus or as an alternative to the eddy-current test. The purchaser shall have the option to specify either a hydrostatic test in 11.3.1 or the pneumatic test in 11.3.2. When, in the case where subsequent testing by the purchaser establishes that the material does not meet these requirements, then the tubes shall be subject to rejection.

TABLE 4 Mechanical Property Requirements of Annealed Temper Tube—Inch-Pound Values

Copper Alloy UNS No.	Temper Designation <sup>A</sup>		Wall Thickness, in.	Rockwell Hardness <sup>B</sup>		Average Grain Size, mm	
	Standard	Former		Scale	Max	Min	Max
C22000	O60	soft anneal	up to 0.045, incl	30T	30	0.025	0.060
C22000	O60	soft anneal	over 0.045	F	70	0.025	0.060
C22000	O50	light anneal	up to 0.045, incl	30T	37	<sup>C</sup>	0.035
C22000	O50	light anneal	over 0.045	F	78	<sup>C</sup>	0.035
C23000	O60	soft anneal	up to 0.045, incl	30T	36	0.025	0.060
C23000	O60	soft anneal	over 0.045	F	75	0.025	0.060
C23000	O50	light anneal	up to 0.045, incl	30T	39	<sup>C</sup>	0.035
C23000	O50	light anneal	over 0.045	F	85	<sup>C</sup>	0.035
C26000, C33000, and C33200	O60	soft anneal	up to 0.030, incl	30T	40	0.025	0.060
C26000, C33000, and C33200	O60	soft anneal	over 0.030	F	80	0.025	0.060
C26000, C28000, C33000, C332000, and C37000	O50	light anneal	up to 0.030, incl	30T	60	<sup>C</sup>	0.035
C26000, C28000, C33000, C332000, and C37000	O50	light anneal	over 0.030	F	90	<sup>C</sup>	0.035
C27000, C27200, and C27400	O60	soft anneal	up to 0.030, incl	30T	40	0.025	0.060
C27000, C27200, and C27400	O60	soft anneal	over 0.030	F	80	0.025	0.060
C27000, C27200, and C27400	O50	light anneal	up to 0.030, incl	30T	60	<sup>C</sup>	0.035
C27000, C27200, and C27400	O50	light anneal	over 0.030	F	90	<sup>C</sup>	0.035
C44300	O60	soft anneal	up to 0.030, incl	30T	40	0.025	0.060
C44300	O60	soft anneal	over 0.030	F	80	0.025	0.060
C44300	O50	light anneal	up to 0.030, incl	30T	60	<sup>C</sup>	0.035
C44300	O50	light anneal	over 0.030	F	90	<sup>C</sup>	0.035

<sup>A</sup> Standard designations defined in Classification B601.

<sup>B</sup> Rockwell hardness values shall apply only to tubes having a wall thickness of 0.015 in. or over and to round tubes having an inside diameter of 5/16 in. or over and to rectangular including square tubes having an inside major distance between parallel surfaces of 3/16 in. or over. For all other tube no Rockwell hardness values shall apply. Rockwell hardness tests shall be made on the inside surface of the tube. When suitable equipment is not available for determining the specified Rockwell hardness, other Rockwell scales and values shall be specified subject to agreement between the manufacturer and the purchaser.

<sup>C</sup> Although no minimum grain size is specified, the product must nevertheless have a fully recrystallized grain structure.

11.3.1 *Hydrostatic Test*—When specified, the tube shall stand, without showing evidence of leakage an internal hydrostatic pressure sufficient to subject the material to a fiber stress of 7000 psi [48 MPa], determined by the following equation for thin hollow cylinders under tension:

$$P = 2St/(D - 0.8t) \quad (1)$$

where:

$P$  = hydrostatic pressure, psi [MPa];  
 $t$  = wall thickness of the material, in. [mm];  
 $D$  = outside diameter of the material, in. [mm]; and  
 $S$  = allowable stress of the material.

11.3.2 *Pneumatic Test*—When specified, the tube shall be subjected to an internal air pressure of 60 psig [400 kPa] minimum for 5 s without showing evidence of leakage. The test method used shall provide for easy visual detection of any leakage, such as by immersion of the tube under water or by the pressure differential method. Any evidence of leakage shall be cause for rejection.

## 12. Dimensions and Permissible Variations

12.1 The dimensions and tolerances for material covered by this specification shall be as prescribed in the current edition of

Specification B251/B251M, with particular reference to Section 5 and the following tables of that specification:

12.2 *Wall Thickness Tolerances*—See 5.2, Tables 1 and 6.

12.3 *Tolerances for Diameter or Distance Between Parallel Surfaces*—See 5.3, Tables 2 and 7.

12.4 *Length Tolerances*—See 5.5, Tables 3 and 4.

12.5 *Roundness*—See 5.4.

12.6 *Squareness of Cut*—See 5.6

12.7 *Straightness Tolerances*—For round tubes see 5.7.1, Table 5. For rectangular including square tubes see 5.7.2.

12.8 *Corner Radius for Rectangular Including Square Tubes*—See 5.8, Table 8.

12.9 *Twist Tolerances for Rectangular and Square Tubes*—See 5.9.

## 13. Sampling for Visual and Dimensional Examination

13.1 Minimum sampling for visual and dimensional examination shall be as follows when specified by the purchaser in the inquiry, contract or order, for agencies of the U.S. Government:

TABLE 5 Mechanical Property Requirements of Annealed Temper Tube—SI Values

Copper Alloy UNS No.	Temper Designation <sup>A</sup>		Wall Thickness, mm	Rockwell Hardness <sup>B</sup>		Average Grain Size, mm	
	Standard	Former		Scale	Max	Min	Max
C22000	O60	soft anneal	up to 1.0, incl	30T	30	0.025	0.060
C22000	O60	soft anneal	over 1.0	F	70	0.025	0.060
C22000	O50	light anneal	up to 1.0, incl	30T	37	<sup>c</sup>	0.035
C22000	O50	light anneal	over 1.0	F	78	<sup>c</sup>	0.035
C23000	O60	soft anneal	up to 1.0, incl	30T	36	0.025	0.060
C23000	O60	soft anneal	over 1.0	F	75	0.025	0.060
C23000	O50	light anneal	up to 1.0, incl	30T	39	<sup>c</sup>	0.035
C23000	O50	light anneal	over 1.0	F	85	<sup>c</sup>	0.035
C26000, C33000, and C33200	O60	soft anneal	up to 0.080, incl	30T	40	0.025	0.060
C26000, C33000, and C33200	O60	soft anneal	over 0.080	F	80	0.025	0.060
C26000, C28000, C33000, C33200, and C37000	O50	light anneal	up to 0.080, incl	30T	60	<sup>c</sup>	0.035
C26000, C28000, C33000, C33200, and C37000	O50	light anneal	over 0.080	F	90	<sup>c</sup>	0.035
C27000, C27200, and C27400	O60	soft anneal	up to 0.080, incl	30T	40	0.025	0.060
C27000, C27200, and C27400	O60	soft anneal	over 0.080	F	80	0.025	0.060
C27000, C27200, and C27400	O50	light anneal	up to 0.080, incl	30T	60	<sup>c</sup>	0.035
C27000, C27200, and C27400	O50	light anneal	over 0.080	F	90	<sup>c</sup>	0.035
C44300	O60	soft anneal	up to 0.080, incl	30T	40	0.025	0.060
C44300	O60	soft anneal	over 0.080	F	80	0.025	0.060
C44300	O50	light anneal	up to 0.080, incl	30T	60	<sup>c</sup>	0.035
C44300	O50	light anneal	over 0.080	F	90	<sup>c</sup>	0.035

<sup>A</sup> Standard designations defined in Classification B601.

<sup>B</sup> Rockwell hardness values shall apply only to tubes having a wall thickness of 0.40 mm or over and to round tubes having an inside diameter of 8.0 mm or over and to rectangular including square tubes having an inside major distance between parallel surfaces of 5.0 mm or over. For all other tube, no Rockwell hardness values shall apply. Rockwell hardness tests shall be made on the inside surface of the tube. When suitable equipment is not available for determining the specified Rockwell hardness, other Rockwell scales and values shall be specified subject to agreement between the manufacturer and the purchaser.

<sup>C</sup> Although no minimum grain size is specified, the product must nevertheless have a fully recrystallized grain structure.

Lot Size (Pieces Per Lot)

Sample Size

2 to 8	Entire lot
9 to 90	8
91 to 150	12
151 to 280	19
281 to 500	21
501 to 1200	27
1201 to 3200	35
3201 to 10 000	38
10 001 to 35 000	46

13.2 In all cases, the acceptance number is zero and the rejection number is one. Screening and resubmittal of samples

from rejected lots for visual and dimensional examination is acceptable. All defective items shall be replaced with acceptable items before lot acceptance.

#### 14. Workmanship, Finish, and Appearance

14.1 Annealed tube shall be either bright annealed or acid cleaned after final annealing operations.

#### 15. Keywords

15.1 brass tube; seamless brass tube; seamless tube

## SUPPLEMENTARY REQUIREMENTS

The following supplementary requirements shall apply only when specified by the purchaser in the inquiry, contract, or order, for agencies of the U.S. Government. Supplementary Requirement S5 shall apply only when specified.

### S1. Referenced Documents

S1.1 The following documents of the issue in effect on date of material purchase form a part of this specification to the extent referenced herein:

S1.1.1 *ASTM Standard:*

B900, Practice for Packaging of Copper and Copper Alloy Mill Products for U.S. Government Agencies

S1.1.2 *Federal Standards:*

Fed. Std. No. 102 Preservation, Packaging and Packing Levels

Fed. Std. No. 123 Marking for Shipment (Civil Agencies)

Fed. Std. No. 185 Identification Marking of Copper and Copper-Base Alloy Mill Products

S1.1.3 *Military Standard:*

MIL-STD-129 Marking for Shipment and Storage

### S2. Quality Assurance

S2.1 *Responsibility for Inspection:*

S2.1.1 Unless otherwise specified in the contract or purchase order, the manufacturer is responsible for the performance of all inspection and test requirements specified. Except as otherwise specified in the contract or purchase order, the manufacturer shall use his own or any other suitable facilities for the performance of the inspection and test requirements unless disapproved by the purchaser at the time the order is placed. The purchaser shall have the right to perform any of the inspections or tests set forth when such inspections and tests are deemed necessary to assure that the material conforms to prescribed requirements.

### S3. Identification Marking

S3.1 All material shall be properly marked for identification in accordance with Fed. Std. No. 185 except that the ASTM specification number and the alloy number shall be used.

### S4. Preparation for Delivery

S4.1 *Preservation, Packaging, Packing:*

S4.1.1 *Military Agencies*—The material shall be separated by size, composition, grade or class and shall be preserved and packaged, Level A or C, packed, Level A, B, or C as specified in the contract or purchase order, in accordance with the requirements of Practice B900.

S4.1.2 *Civil Agencies*—The requirements of Fed. Std. No. 102 shall be referenced for definitions of the various levels of packaging protection.

S4.2 *Marking:*

S4.2.1 *Military Agencies*—In addition to any special marking required by the contract or purchase order, marking for shipment shall be in accordance with MIL-STD-129.

S4.2.2 *Civil Agencies*—In addition to any special marking required by the contract or purchase order, marking for shipment shall be in accordance with Fed. Std. No. 123.

### S5. Tubes for Voice and Pneumatic Service

S5.1 Tubes ordered to this supplement for voice and pneumatic service shall have dimensions, tolerances, and tempers as specified in Table S5.1. For these tubes, the mercurous nitrate test shall be required and nondestructive testing shall not be required. Copper plus sum of all named elements shall be 98.85 %.

TABLE S5.1 Tubes for Voice and Pneumatic Service

Size	Outside Diameter, in. [mm]	Inside Diameter, in. [mm]	Average Diameter Tolerance, in. [mm]	Wall Thickness, in. [mm]	Temper
A	2.000 [50.8]	...	+0.000 -0.004 [-0.10]	0.049 [1.25]	H-80
B	2.000 [50.8]	...	+0.000 -0.004 [-0.10]	0.109 [2.75]	H-58
C	...	2.000 [50.8]	+0.004 [0.10] -0.000	0.049 [1.25]	H-80
D	2.250 [57.2]	...	+0.000 -0.004 [-0.10]	0.065 [1.65]	H-80
E	...	2.250 [57.2]	+0.004 [0.10] -0.000 [0.00]	0.049 [1.25]	H-80
F	3.000 [76.2]	...	+0.000 -0.004 [-0.10]	0.049 [1.25]	H-80
G	3.000 [76.2]	...	+0.000 -0.004 [-0.10]	0.109 [2.75]	H-58
H	...	3.000 [76.2]	+0.004 [0.10] -0.000	0.049 [1.25]	H-80

ASME BPVC Section II part B) 2025

ASME BPVC.II.B (ASME BPVC Section II part B) 2025

ASMENORMDOC.COM : Click to view the full PDF of ASME BPVC.II.B (ASME BPVC Section II part B) 2025

ASMENORMDOC.COM : Click to view the full PDF of ASME BPVC.II.B (ASME BPVC Section II part B) 2025

INTENTIONALLY LEFT BLANK

## SPECIFICATION FOR ALUMINUM-BRONZE SAND CASTINGS



**SB-148**

(Identical with ASTM Specification B148-18 except certification and test report have been made mandatory, and weld repair requirements in accordance with ASME Section IX have been added.)

ASMENORMDOC.COM : Click to view the full PDF of ASME BPVC.II.B (ASME BPVC Section II part B) 2025

# Specification for Aluminum-Bronze Sand Castings

## 1. Scope

1.1 This specification establishes requirements for sand castings produced from copper-base alloys having the alloy numbers, commercial designations, and nominal compositions shown in Table 1.

1.2 The values stated in inch-pound units are to be regarded as standard. The values given in parentheses are mathematical conversions to SI units that are provided for information only and are not considered standard.

1.3 *This international standard was developed in accordance with internationally recognized principles on standardization established in the Decision on Principles for the Development of International Standards, Guides and Recommendations issued by the World Trade Organization Technical Barriers to Trade (TBT) Committee.*

## 2. Referenced Documents

2.1 The following documents of the issue in effect on date of material purchase form a part of this specification to the extent referenced herein:

2.2 *ASTM Standards:*

B208 Practice for Preparing Tension Test Specimens for Copper Alloy Sand, Permanent Mold, Centrifugal, and Continuous Castings

B824 Specification for General Requirements for Copper Alloy Castings

B846 Terminology for Copper and Copper Alloys

E8/E8M Test Methods for Tension Testing of Metallic Materials

E10 Test Method for Brinell Hardness of Metallic Materials

E18 Test Methods for Rockwell Hardness of Metallic Materials

E527 Practice for Numbering Metals and Alloys in the Unified Numbering System (UNS)

## 3. Terminology

3.1 For definitions of terms related to copper and copper alloys, refer to Terminology B846.

## 4. General Requirements

4.1 Material furnished under this specification shall conform to the applicable requirements of Specification B824.

## 5. Ordering Information

5.1 Include the following specified choices when placing orders for product under this specification as applicable:

5.1.1 ASTM designation and year of issue,

5.1.2 Copper or Copper Alloy UNS. No. designation,

5.1.3 Temper, must include optional Heat Treatment when needed,

5.1.4 Dimensions, diameter, and wall thickness (For tube or pipe: specify either O.D./I.D., O.D./Wall, or I.D./Wall unless standard size such as type K are ordered; for flat products: thickness, width, and edges; for rod, bar, or shapes: by diameter or distance between parallel surfaces),

5.1.5 Quantity of castings required,

5.1.6 Intended applications,

5.1.7 Specification title, number, and year of issue,

5.1.8 Pattern or drawing number and condition (cast, machined, and so forth),

5.1.9 Analysis of residual elements, if specified in the purchase order (Specification B824),

5.1.10 Pressure test requirements, if specified in the purchase order (Specification B824),

5.1.11 Soundness requirements, if specified in the purchase order (Specification B824),

5.1.12 Certification (Specification B824),

5.1.13 Test report (Specification B824),

5.1.14 Witness inspection, if specified in the purchase order (Specification B824),

TABLE 1 Nominal Compositions

Copper Alloy UNS No.	Old Designation	Commercial Designation	Nominal Composition, %					
			Copper	Nickel	Iron	Aluminum	Silicon	Manganese
C95200	9A	Grade A	88.0	...	3.0	9.0	...	...
C95300 <sup>A</sup>	9B	Grade B	89.0	...	1.0	10.0	...	...
C95400 <sup>A</sup>	9C	Grade C	85.0	...	4.0	11.0	...	...
C95410 <sup>A</sup>	...	...	84.0	2.0	4.0	10.0	...	...
C95500 <sup>A</sup>	9D	Grade D	81.0	4.0	4.0	11.0	...	...
C95520 <sup>A</sup>	...	...	78.5	5.5	5.0	11.0	...	...
C95600	9E	Grade E	91.0	...	...	7.0	2.0	...
C95700	9F	Grade F	75.0	2.0	3.0	8.0	...	12.0
C95800	...	...	81.3	4.5	4.0	9.0	...	1.2
C95820	...	...	79.0	5.2	4.5	9.5	...	1.0
C95900	...	...	87.5	...	4.5	13.0	...	...

<sup>A</sup> These grades respond to heat treatment.

5.1.15 Approval of weld procedure and records of repairs, if specified in the purchase order (Section 10),

5.1.16 DELETED

5.1.17 Castings for seawater service (6.2.3), and

5.1.18 Product marking, if specified in the purchase order (Specification B824).

5.2 When material is purchased for agencies of the U.S. Government, the Supplementary Requirements of this specification may be specified.

## 6. Materials and Manufacture

### 6.1 Materials:

6.1.1 The material of manufacture shall be sand castings of Copper Alloys, UNS No. C95200, C95300, C95400, C95410, C95500, C95520, C95600, C95700, C95800, C95820, C95900 of such purity and soundness as to be suitable for processing into the products prescribed herein.

6.1.2 When specified in the contract or purchase order, that heat identification or traceability is required, the purchaser shall specify the details desired.

### 6.2 Manufacture:

6.2.1 As a specified option, Copper Alloy UNS Nos. C95300, C95400, C95410, C95500, and C95520 may be supplied in the heat-treated condition to obtain the higher

TABLE 2 Mechanical Requirements

Classification	Aluminum Bronze			Nickel Aluminum Bronze		Silicon Aluminum Bronze	Manganese- Nickel Aluminum Bronze	Nickel Aluminum Bronze	Aluminum Bronze
	As-Cast		C95400 and C95410	As-Cast					
Copper Alloy UNS No.	C95200	C95300	C95400 and C95410	C95500	C95820	C95600	C95700	C95800 <sup>A</sup>	C95900 <sup>B</sup>
Tensile strength, min, ksi <sup>C</sup> (MPa) <sup>D</sup>	65 (450)	65 (450)	75 (515)	90 (620)	94 (650)	60 (415)	90 (620)	85 (585)	...
Yield strength, <sup>E</sup> min, ksi <sup>C</sup> (MPa) <sup>D</sup>	25 (170)	25 (170)	30 (205)	40 (275)	39 <sup>F</sup> (270) <sup>F</sup>	28 (195)	40 (275)	35 (240)	...
Elongation in 2 in. (50.8 mm), %	20	20	12	6	13	10	20	15	...
Brinell hardness No. <sup>G</sup> (3000-kg load)	110	110	150	190	...	...	...	...	...
Heat-Treated									
Copper Alloy UNS No.	...	C95300	C95400 and C95410	C95500	C95520 <sup>H</sup>	...	...	...	...
Tensile strength, min, ksi <sup>C</sup> (MPa) <sup>D</sup>	...	80 (550)	90 (620)	110 (760)	125 (862)	...	...	...	...
Yield strength, <sup>E</sup> min, ksi <sup>C</sup> (MPa) <sup>D</sup>	...	40 (275)	45 (310)	60 (415)	95 <sup>F</sup> (655) <sup>F</sup>	...	...	...	...
Elongation in 2 in. (50.8 mm), %	...	12	6	5	2	...	...	...	...
Brinell hardness No. <sup>G</sup> (3000-kg load)	...	160	190	200	255 <sup>I</sup>	...	...	...	241 min

<sup>A</sup> As cast or temper annealed.

<sup>B</sup> Normally supplied annealed between 1100 and 1300 °F for 4 h followed by air cooling.

<sup>C</sup> ksi = 1000 psi.

<sup>D</sup> See Appendix X1.

<sup>E</sup> Yield strength shall be determined as the stress producing an elongation under load of 0.5 %, that is, 0.01 in. (0.254 mm) in a gage length of 2 in. (50.8 mm).

<sup>F</sup> Yield strength at 0.2 % offset, min, ksi<sup>C</sup> (MPa)<sup>D</sup>.

<sup>G</sup> For information only.

<sup>H</sup> Copper Alloy UNS No. C95520 is used in the heat-treated condition only.

<sup>I</sup> Sand castings and sand cast test specimens shall be 25 HRC minimum.

mechanical properties shown in Table 2. Suggested heat treatments for these alloys are given in Table 3. Actual practice may vary by manufacturer.

6.2.2 For better corrosion resistance in seawater applications, castings in Copper Alloy UNS No. C95800 may be given a temper anneal heat treatment at 1200 to 1300 °F (650 to 705 °C) for 6 h minimum. Cooling shall be by the fastest means possible that will not cause excessive distortion or cracking. Propeller castings shall be exempt from this requirement.

6.2.3 Copper Alloy UNS No. C95520 is used in the heat-treated condition only.

6.2.4 Copper Alloy UNS No. C95900 is normally supplied annealed between 1100 °F (595 °C) and 1300 °F (705 °C) followed by air cooling.

6.2.5 Copper Alloy UNS No. C95820 is supplied in the as-cast condition.

6.2.6 Separately cast test bar coupons representing castings made in Copper Alloy UNS Nos. C95300HT, C95400HT, C95410HT, C95500HT, C95520HT, C95800 temper annealed, and C95900 annealed shall be heat treated with the castings.

## 7. Chemical Composition

7.1 The material shall conform to the chemical composition requirements in Table 4 for the copper alloy UNS. No. designation specified in the ordering information.

7.1.1 Results of analysis of the product sample shall conform to the composition requirements within the permitted analytical variance specified in Table 4.

7.1.2 These composition limits do not preclude the presence of other elements. Limits may be established by agreement between manufacturer or supplier and purchaser for the unnamed elements.

7.1.3 For alloys in which Copper is listed as remainder, copper is the difference between the sum of results of all elements determined and 100 %. When all the elements in Table 4 are determined, the sum of results shall be as specified in the following table:

**TABLE 3 Suggested Heat Treatments**

Copper Alloy UNS No.	Solution Treatment (Not Less than 1 h/in. Followed by Water Quench)	Annealing Treatment (Not Less than 2 h Followed by Air Cool)
C95300	1585–1635 °F (860–890 °C)	1150–1225 °F (620–660 °C)
C95400 C95410	1600–1675 °F (870–910 °C)	1150–1225 °F (620–660 °C)
C95500 C95520	(2 h followed by water quench) 1600–1700 °F (870–925 °C)	925–1000 °F (495–540 °C)
C95800 <sup>A</sup>		1200–1300 °F (650–705 °C), 6 h minimum followed by air cooling

<sup>A</sup> Corrosion inhibiting heat treatment, depends on agreement between the manufacturer and buyer.

Copper Alloy UNS Number	Copper Plus Named Elements, min, %
C95200	99.0
C95300	99.0
C95400	99.5
C95410	99.5
C95500	99.5
C95520	99.5
C95600	99.0
C95700	99.5
C95800	99.5
C95820	99.2
C95900	99.5

## 8. Temper

8.1 The suggested heat treatment (tempers) for products described in this specification are given in Table 3.

## 9. Mechanical Property Requirements

### 9.1 Tensile Strength Requirements:

9.1.1 The mechanical properties shall be determined from separately cast test bar castings.

9.1.2 Product furnished under this specification shall conform to the mechanical properties requirements specified in Table 2, when tested in accordance with Test Methods E8/E8M.

9.1.3 Acceptance or rejection based upon mechanical properties shall depend on tensile strength, yield strength, and elongation.

### 9.2 Hardness Requirement:

9.2.1 The approximate Brinell hardness values given in Table 2 are for general information and assistance in testing, and shall not be used as a basis for product rejection.

## 10. Casting Repair

10.1 Alloys included in this specification are generally weldable. All weld repairs shall be made utilizing procedures qualified in accordance with Section IX of the ASME BPVC, and repair welding shall be done by welders or welding operators in accordance with ASME BPVC Section IX. Weld repairs may be made at the manufacturer's discretion provided each excavation does not exceed 20 % of the casting section or wall thickness or 4 % of the casting surface area.

10.2 Excavations that exceed those described in 10.1 may be made at the manufacturer's discretion except that when required (5.1.15) the weld procedure shall be approved by the purchaser and the following records shall be maintained:

10.2.1 A sketch or drawing showing the dimensions, depth, and location of excavations,

10.2.2 Postweld heat treatment, when applicable,

10.2.3 Weld repair inspection results,

10.2.4 Casting identification number,

10.2.5 Weld procedure identification number,

10.2.6 Welder identification, and

10.2.7 Name of inspector.

10.3 The castings shall not be impregnated without approval of the purchaser.

TABLE 4 Chemical Requirements

Classification	Aluminum Bronze				Nickel Aluminum Bronze		Silicon Aluminum Bronze	Manganese- Nickel Aluminum Bronze	Nickel Aluminum Bronze		Aluminum Bronze
	C95200	C95300	C95400	C95410	C95500	C95520 <sup>A</sup>	C95600	C95700	C95800	C95820 <sup>B</sup>	C95900
	Composition, %										
Copper	86.0 min	86.0 min	83.0 min	83.0 min	78.0 min	74.5 min	88.0 min	71.0 min	79.0 min	77.5 min	remainder
Aluminum	8.5–9.5	9.0–11.0	10.0–11.5	10.0–11.5	10.0–11.5	10.5–11.5	6.0–8.0	7.0–8.5	8.5–9.5	9.0–10.0	12.0–13.5
Iron	2.5–4.0	0.8–1.5	3.0–5.0	3.0–5.0	3.0–5.0	4.0–5.5	...	2.0–4.0	3.5–4.5 <sup>C</sup>	4.0–5.0	3.0–5.0
Manganese	...	...	0.50 max	0.50 max	3.5 max	1.5 max	...	11.0–14.0	0.8–1.5	1.5 max	1.5 max
Nickel (incl cobalt)	...	...	1.5 max	1.5–2.5	3.0–5.5	4.2–6.0	0.25 max	1.5–3.0	4.0–5.0 <sup>C</sup>	4.5–5.8	0.50 max
Silicon	...	...	...	...	...	0.15 max	1.8–3.2	0.10 max	0.10 max	0.10 max	...
Lead	...	...	...	...	...	0.03 max	...	0.03 max	0.03 max	0.03 max	...

<sup>A</sup> Chromium shall be 0.05 max, cobalt 0.20 max, tin 0.25 max, and zinc 0.30 max.

<sup>B</sup> Zinc shall be 0.20 max and tin 0.20 max.

<sup>C</sup> Iron content shall not exceed the nickel content.

## 11. Workmanship, Finish, and Appearance

11.1 The product shall be free of defects, but blemishes of a nature that do not interfere with the intended application are acceptable.

## 12. Sampling

12.1 Test bar castings for the Copper Alloy UNS Nos. in this specification shall be cast to the form and dimensions shown in Figs. 1 or 2 in Practice B208.

12.2 For small remelts the lot size shall not exceed 1000 lb (455 kg) of castings and shall consist of all of the metal from a single master heat poured from an individual melting unit, or group of melting units, operating during the course of one half shift, not to exceed 5 h.

## 13. Test Methods

### 13.1 Chemical Analysis:

13.1.1 In case of disagreement, test methods for chemical analysis shall be subject to agreement between the manufacturer and the purchaser.

### 13.2 Other Tests:

13.2.1 Brinell readings shall be taken on the grip end of the tension test bar and shall be made in accordance with Test Method E10, with the exception that a 3000-kg load shall be used.

13.2.2 Rockwell hardness readings shall be taken on the grip end of the tension test bar and shall be made in accordance with Test Methods E18.

13.2.3 Tensile and Yield Strength shall be determined by the extension-under-load method of Test Methods E8/E8M.

13.2.4 When specified in the purchase order, additional hardness testing may be performed on castings. The test location and hardness values shall be agreed upon between the manufacturer and the purchaser.

## 14. Certification and Test Report

14.1 The purchaser shall be furnished certification that samples representing each lot have been tested and inspected as directed in this specification and requirements have been met. A report of the test results shall be furnished to the purchaser.

14.2 DELETED

## 15. Keywords

15.1 aluminum-bronze castings; copper alloy castings; copper-base alloy castings; UNS No. C95200; UNS No. C95300; UNS No. C95400; UNS No. C95410; UNS No. C95500; UNS No. C95520; UNS No. C95600; UNS No. C95700; UNS No. C95800; UNS No. C95820; UNS No. C95900

## SUPPLEMENTARY REQUIREMENTS

The following supplementary requirements shall apply only when specified by the purchaser in the inquiry, contract, or order for agencies of the U.S. Government.

### S1. Scope

S1.1 The following supplementary requirements shall apply only when specified by the purchaser in the inquiry, contract, or order for agencies of the U.S. Government.

### S2. Referenced Documents

S2.1 The following documents of the issue effect on date of material purchase form a part of this specification to the extent referenced herein:

### S2.1.1 *Federal Standards:*

Fed. Std. No. 102 Preservation, Packaging, and Packing Levels

Fed. Std. No. 123 Marking for Shipment (Civil Agencies)

### S2.1.2 *Military Standards:*

MIL-STD-129 Marking for Shipment and Storage

MIL-STD-248 Welded and Brazing Procedure in Performance Qualification

MIL-STD-271 Requirements for Nondestructive Testing Methods

MIL-STD-278 Welding and Casting Standard

### S2.1.3 *ASTM Standard:*

B900 Practice for Packaging of Copper and Copper Alloy Mill Products for U.S. Government Agencies

## S3. First Article Inspection

S3.1 The initial casting shall be radiographically examined in accordance with MIL-STD-271 at locations specified by the purchaser. Subsequent to radiography, samples for mechanical testing shall be removed from the specified locations and tested. The acceptance criteria for all tests and examinations shall be as agreed upon between the manufacturer and the purchaser.

S3.2 Following acceptance of the initial casting by the purchaser, the manufacturer shall not change his basic foundry practice without the specific approval of the purchaser. The manufacturer may be required to perform additional tests or inspections to verify acceptability of any changes made.

## S4. Soundness

S4.1 Castings shall meet the soundness requirements of MIL-STD-278 for the category, subcategory, and criticality level specified in the purchase order.

## S5. Pressure Test

S5.1 Castings shall meet the pressure test requirements of MIL-STD-278.

## S6. Weld Repair

S6.1 All repair welding shall be in accordance with MIL-STD-278 using welders and welding procedures qualified in accordance with MIL-STD-248.

S6.2 Surfaces of the casting that will be in contact with seawater will be identified by the purchaser. Any weld repair made on these surfaces or within ¼ in. of these surfaces shall be postweld heat treated in accordance with 6.2.3.

## S7. Quality Assurance

S7.1 *Responsibility for Inspection*—Unless otherwise specified in the contract or purchase order, the manufacturer is responsible for performance of all inspection and test requirements specified. Except as otherwise specified in the contract or purchase order, the manufacturer may use his own or any other suitable facilities for the performance of the inspection and test requirements unless disapproved by the purchaser at the time the order is placed. The purchaser shall have the right to perform any of the inspections or tests set forth when such inspections and tests are deemed necessary to ensure that the material conforms to prescribed requirements.

## S8. Marking

S8.1 The castings shall be marked in accordance with Specification B824. Additionally, the marking shall include the manufacturer's trademark, specification, and alloy number.

## S9. Preparation for Delivery

### S9.1 *Preservation, Packaging, and Packing:*

S9.1.1 *Military Agencies*—The material shall be separated by size, composition, grade, or class and shall be preserved and packaged, Level A or C, packed, Level A, B, or C as specified in the contract or purchase order, in accordance with the requirements of Practice B900.

S9.1.2 *Civil Agencies*—The requirements of Fed. Std. No. 102 shall be referenced for definitions of the various levels of packaging protection.

### S9.2 *Marking:*

S9.2.1 *Military Agencies*—In addition to any special marking required by the contract or purchase order, marking for shipment shall be in accordance with MIL-STD-129.

S9.2.2 *Civil Agencies*—In addition to any special marking required by the contract or purchase order, marking for shipment shall be in accordance with Fed. Std. No. 123.

**APPENDIX****(Nonmandatory Information)****X1. METRIC EQUIVALENTS**

X1.1 The SI unit for strength properties now shown is in accordance with the International System of Units (SI). The derived SI unit for force is the newton (N), which is defined as that force that, when applied to a body having a mass of one kilogram, gives it an acceleration of one metre per second square ( $N = \text{kg}\cdot\text{m}/\text{s}^2$ ). The derived SI unit for pressure or stress

is the newton per square metre ( $\text{N}/\text{m}^2$ ), which has been named the pascal (Pa) by the General Conference on Weights and Measures. Since  $1 \text{ ksi} = 6\,894\,757 \text{ Pa}$ , the metric equivalents are expressed as megapascal (MPa), which is the same as  $\text{MN}/\text{m}^2$  and  $\text{N}/\text{mm}^2$ .

ASMENORMDOC.COM : Click to view the full PDF of ASME BPVC.II.B (ASME BPVC Section II Part B) 2025

ASMENORMDOC.COM : Click to view the full PDF of ASME BPVC.II.B (ASME BPVC Section II part B) 2025

INTENTIONALLY LEFT BLANK

# SPECIFICATION FOR ALUMINUM BRONZE ROD, BAR, AND SHAPES



**SB-150/SB-150M**

(Identical with ASTM Specification B150/B150M-12(2017) except that paras. 4.2.2, 4.2.3, 4.2.6, and 8.2.1 have been deleted.)

# Specification for Aluminum Bronze Rod, Bar, and Shapes

## 1. Scope

1.1 This specification establishes the requirements for aluminum bronze rod, bar, and shapes for Copper Alloys UNS Nos. C61300, C61400, C61900, C62300, C62400, C63000, C63020, C63200, C64200, and C64210.

NOTE 1—Product intended for hot forging is described in Specification B124/B124M.

NOTE 2—**Warning**—Mercury has been designated by many regulatory agencies as a hazardous material that can cause serious medical issues. Mercury, or its vapor, has been demonstrated to be hazardous to health and corrosive to materials. Caution should be taken when handling mercury and mercury containing products. See the applicable product Safety Data Sheet (SDS) for additional information. Users should be aware that selling mercury and/or mercury containing products into your state or country may be prohibited by law.

1.2 The values stated in either SI units or inch-pound units are to be regarded separately as standard. The values stated in each system may not be exact equivalents; therefore, each system shall be used independently of the other. Combining values from the two systems may result in non-conformance with the standard.

1.3 *This standard does not purport to address all of the safety concerns, if any, associated with its use. It is the responsibility of the user of this standard to establish appropriate safety and health practices and determine the applicability of regulatory requirements prior to use.*

1.4 *This international standard was developed in accordance with internationally recognized principles on standardization established in the Decision on Principles for the Development of International Standards, Guides and Recommendations issued by the World Trade Organization Technical Barriers to Trade (TBT) Committee.*

## 2. Referenced Documents

2.1 *ASTM Standards:*

B124/B124M Specification for Copper and Copper Alloy Forging Rod, Bar, and Shapes  
 B154 Test Method for Mercurous Nitrate Test for Copper Alloys  
 B249/B249M Specification for General Requirements for Wrought Copper and Copper-Alloy Rod, Bar, Shapes and Forgings  
 B601 Classification for Temper Designations for Copper and Copper Alloys—Wrought and Cast  
 B858 Test Method for Ammonia Vapor Test for Determining Susceptibility to Stress Corrosion Cracking in Copper Alloys  
 E8/E8M Test Methods for Tension Testing of Metallic Materials  
 E18 Test Methods for Rockwell Hardness of Metallic Materials  
 E53 Test Method for Determination of Copper in Unalloyed Copper by Gravimetry  
 E62 Test Methods for Chemical Analysis of Copper and Copper Alloys (Photometric Methods) (Withdrawn 2010)  
 E118 Test Methods for Chemical Analysis of Copper-Chromium Alloys (Withdrawn 2010)  
 E478 Test Methods for Chemical Analysis of Copper Alloys

## 3. General Requirements

3.1 The following sections of Specification B249/B249M constitute a part of this specification:

- 3.1.1 Terminology,
- 3.1.2 Materials and Manufacture,
- 3.1.3 Workmanship, Finish, and Appearance,
- 3.1.4 Sampling,
- 3.1.5 Number of Tests and Retests,
- 3.1.6 Specimen Preparation,
- 3.1.7 Test Methods,
- 3.1.8 Significance of Numerical Limits,
- 3.1.9 Inspection,
- 3.1.10 Rejection and Rehearing,
- 3.1.11 Certification,
- 3.1.12 Mill Test Report,
- 3.1.13 Packaging and Package Marking, Preservation and Delivery, and

### 3.1.14 Supplementary Requirements.

3.2 In addition, when a section with a title identical to those referenced in 3.1, appears in this specification, it contains additional requirements that supplement those appearing in Specification B249/B249M.

## 4. Ordering Information

4.1 Include the following information when placing orders for product under this specification, as applicable:

4.1.1 Specification designation and year of issue,

4.1.2 Copper alloy UNS No. (See Table 1),

4.1.3 Temper (see Temper section),

4.1.3.1 When Alloy UNS No. C63000 is specified, specify standard strength or high strength temper (See Table 2),

4.1.4 Product cross-section (for example round, hexagonal, square, and so forth),

4.1.5 Dimensions (diameter or distance between parallel surfaces and length) and permissible variations (Section 10),

4.1.5.1 When product of Copper Alloy UNS No. C63020 is specified, the tolerances for diameter, thickness, width, and length shall be part of the contract or purchase order and shall be agreed upon between the supplier and the purchaser.

4.1.5.2 *Shapes*—When product is shapes, the dimensional tolerances shall be as agreed upon between the manufacturer and the purchaser and shall be specified.

4.1.6 Quantity, total weight, footage, or number of pieces for each size.

4.1.7 If product is being purchased for agencies of the U.S. government.

4.2 The following options are available and should be specified at the time of placing the order when required:

4.2.1 If Copper Alloy C61300 material is intended for subsequent welding applications (See Note B, Table 2),

4.2.2 DELETED

4.2.3 DELETED

4.2.4 Residual stress test (Performance Requirements section)

4.2.4.1 Ammonia Vapor Test or Mercurous Nitrate Test,

4.2.4.2 For Ammonia Vapor Test, pH value other than 10.

4.2.5 If piston finish or shafting is required, (Performance Requirements and Workmanship sections), and

4.2.6 DELETED

## 5. Materials and Manufacture

5.1 *Manufacture:*

5.1.1 *Copper Alloy UNS C63020*—Rod and Bar shall be heat-treated to 26 Rockwell hardness (C scale) (HRC) minimum as follows:

5.1.2 Heat to 1550°/1650°F [850/900°C] for 2 h minimum and quenched in water.

5.1.3 Temper at 900°/1000°F [480/540°C] for 2 h minimum and air cool to room temperature.

5.2 *Copper Alloy UNS C63200*—Rod and Bar shall be heat-treated as follows:

5.2.1 Heat to 1550°F [850°C] minimum for 1 h minimum at temperature and quench in water or other suitable medium,

5.2.2 Temper anneal at 1300 ± 25°F [700 ± 15°C] for 3 to 9 h at temperature as required to obtain desired mechanical properties, and

5.2.3 Heat treatment is not mandatory for sections that exceed 12 in. [300 mm] in diameter or thickness.

## 6. Chemical Composition

6.1 The material shall conform by alloy to the chemical composition requirements in Table 1 for the copper alloy UNS designation specified in the ordering information.

6.2 For alloys in which copper is listed as “remainder,” copper is the difference between the sum of all elements determined and 100 %.

TABLE 1 Chemical Requirements

Elements	Composition, %									
	C61300	C61400	C61900	C62300	Copper Alloy UNS No. C62400 C63000		C63020	C63200	C64200	C64210
Aluminum	6.0–7.5	6.0–8.0	8.5–10.0	8.5–10.0	10.0–11.5	9.0–11.0	10.0–11.0	8.7–9.5	6.3–7.6	6.3–7.0
Copper, incl silver	remainder	remainder	remainder	remainder	remainder	remainder	74.5 min	remainder	remainder	remainder
Iron	2.0–3.0	1.5–3.5	3.0–4.5	2.0–4.0	2.0–4.5	2.0–4.0	4.0–5.5	3.5–4.3 <sup>A</sup>	0.30 max	0.30 max
Nickel, incl cobalt	0.15 max	...	...	1.0 max	...	4.0–5.5	4.2–6.0	4.0–4.8 <sup>A</sup>	0.25 max	0.25 max
Manganese	0.20 max	1.0 max	...	0.50 max	0.30 max	1.5 max	1.5 max	1.2–2.0	0.10 max	0.10 max
Silicon	0.10 max	...	...	0.25 max	0.25 max	0.25 max	...	0.10 max	1.5–2.2	1.5–2.0
Tin	0.20–0.50	...	0.6 max	0.6 max	0.20 max	0.20 max	0.25 max	...	0.20 max	0.20 max
Zinc, max	0.10 <sup>B</sup>	0.20	0.8	...	...	0.30	0.30	...	0.50	0.50
Lead, max	0.01	0.01	0.02	...	...	...	0.03	0.02	0.05	0.05
Arsenic, max	...	...	...	...	...	...	...	...	0.15	0.15
Phosphorus, max	0.015	0.015	...	...	...	...	...	...	...	...
Other named elements <sup>B</sup>							<sup>C</sup>			

<sup>A</sup> Iron content shall not exceed nickel content.

<sup>B</sup> When the product is for subsequent welding applications and is so specified by the purchaser, chromium shall be 0.05 % max, cadmium 0.05 % max, zirconium 0.05 % max, and zinc 0.05 % max.

<sup>C</sup> Chromium shall be 0.05 max and cobalt shall be 0.20 max.

TABLE 2 Tensile Requirements

Code	Temper Designation Name	Diameter or Distance Between Parallel Surfaces, <sup>A</sup> in. [mm]	Tensile Strength, min ksi [MPa]	Yield Strength, min ksi [MPa], at 0.5 % Extension Under Load	Elongation in 4 x Diameter or Thickness of Specimen min, % <sup>B</sup>
Copper Alloy UNS No. C61300					
HR50	drawn and stress relieved	<i>rod (round only):</i> ½ [12] and under over ½ [12] to 1 [25], incl over 1 [25] to 2.0 [50] incl over 2 [50] to 3 [80], incl	80 [550] 75 [515] 72 [495] 70 [485]	50 [345] 45 [310] 40 [275] 35 [240]	30 30 30 30
HR50	drawn and stress relieved	<i>rod (hexagonal and octagonal) and bar:</i> ½ [12] and under over ½ [12] to 1 [25], incl over 1 [25] to 2 [50], incl	80 [550] 75 [515] 70 [485]	40 [275] 35 [240] 32 [220]	30 30 30
Copper Alloy UNS No. C61400					
HR50	drawn and stress relieved	<i>rod (round only):</i> ½ [12] and under over ½ [12] to 1 [25], incl over 1 [25] to 2 [50], incl over 2 [50] to 3 [80], incl	80 [550] 75 [515] 70 [485] 70 [485]	40 [275] 35 [240] 32 [220] 30 [205]	30 30 30 30
Copper Alloy UNS No. C61900					
HR50	drawn and stress relieved	<i>rod (round only):</i> ½ [12] and under over ½ [12] to 1 [25], incl over 1 [25] to 2 [50], incl over 2 [50] to 3 [80], incl	90 [620] 88 [605] 85 [585] 78 [540]	50 [345] 44 [305] 40 [275] 37 [255]	15 15 20 25
M20	as hot rolled	over 3 [80]	75 [515]	30 [205]	20
M20	as hot rolled	} <i>shapes, all sizes</i>	75 [515]	30 [205]	20
M30	as hot extruded				
O20	hot forged and annealed				
O25	hot rolled and annealed				
O30	hot extruded and annealed				
HR50	drawn and stress relieved				
Copper Alloy UNS No. C62300					
HR50	drawn and stress relieved	<i>rod (round only):</i> ½ [12] and under over ½ [12] to 1 [25], incl over 1 [25] to 2 [50], incl over 2 [50] to 3 [80], incl	90 [620] 88 [605] 84 [580] 76 [525]	50 [345] 44 [305] 40 [275] 37 [255]	12 15 15 20
M20	as hot rolled	} over 3 [80]	75 [515]	30 [205]	20
M30	as hot extruded				
O20	hot forged and annealed				
O25	hot rolled and annealed				
O30	hot extruded and annealed				
HR50	drawn and stress relieved				
HR50	drawn and stress relieved	<i>rod (hexagonal and octagonal) and bar:</i> 1 [25] and under over 1 [25] to 2 [50], incl	80 [550] 78 [540]	35 [240] 32 [220]	15 15
M20	as hot rolled	over 2 [50]	75 [515]	30 [205]	20
M20	as hot rolled	} <i>shapes, all sizes</i>	75 [515]	30 [205]	20
M30	as hot extruded				
O20	hot forged and annealed				
O25	hot rolled and annealed				
O30	hot extruded and annealed				
HR50	drawn and stress relieved				
Copper Alloy UNS No. C62400					
HR50	drawn and stress relieved	<i>rod (round only):</i> ½ [12] and under over ½ [12] to 1 [25], incl over 1 [25] to 2 [50], incl over 2 [50] to 3 [80], incl	95 [655] 95 [655] 90 [620] 90 [620]	45 [310] 45 [310] 43 [295] 40 [275]	10 12 12 12
M20	as hot rolled	} over 3 [80] to 5 [125] incl	90 [620]	35 [240]	12
M30	as hot extruded				
O20	hot forged and annealed	} <i>rod (hexagonal and octagonal) and bar:</i> ½ [12] to 5 [125], incl	90 [620]	35 [240]	12
O25	hot rolled and annealed				
O30	hot extruded and annealed				
		<i>shapes, all sizes</i>	90 [620]	35 [240]	12

TABLE 2 Continued

Code	Temper Designation Name	Diameter or Distance Between Parallel Surfaces, <sup>4</sup> in. [mm]	Tensile Strength, min ksi [MPa]	Yield Strength, min ksi [MPa], at 0.5 % Extension Under Load	Elongation in 4 × Diameter or Thickness of Specimen min, % <sup>5</sup>
TQ50	quench hardened and temper annealed	rod (round only): over 3 [80] to 5 [125], incl	95 [655]	45 [310]	10
Copper Alloy UNS No. C63000					
HR50	drawn and stress relieved	1—standard strength rod: ½ [12] to 1 [25], incl over 1 [25] to 2 [50], incl over 2 [50] to 3 [80], incl	100 [690] 90 [620] 85 [585]	50 [345] 45 [310] 42.5 [295]	5 6 10
M20	as hot rolled	over 3 [80] to 4 [100], incl over 4 [100]	85 [585] 80 [550]	42.5 [295] 40 [275]	10 12
M30	as hot extruded				
O20	hot forged and annealed				
O25	hot rolled and annealed				
O30	hot extruded and annealed				
HR50	drawn and stress relieved				
bar:					
HR50	drawn and stress relieved	½ [12] to 1 [25], incl over 1 [25] to 2 [50], incl	100 [690] 90 [620]	50 [345] 45 [310]	5 6
M20	as hot rolled	over 2 [50] to 4 [100], incl over 4 [100]	85 [585] 80 [550]	42.5 [295] 40 [275]	10 12
M30	as hot extruded				
O20	hot forged and annealed				
O25	hot rolled and annealed				
O30	hot extruded and annealed				
HR50	drawn and stress relieved				
M20	as hot rolled	shapes, all sizes	85 [585]	42.5 [295]	10
M30	as hot extruded				
O20	hot forged and annealed				
O25	hot rolled and annealed				
O30	hot extruded and annealed				
HR50	drawn and stress relieved				
2—high strength rod:					
HR50	drawn and stress relieved	1 [25] and under over 1 [25] to 2 [50], incl	110 [760] 110 [760]	68 [470] 60 [415]	10 10
HR50	drawn and stress relieved	over 2 [50] to 3 [80], incl	105 [725]	55 [380]	10
O26	hot rolled and temper annealed				
TQ50	quench hardened and temper annealed	over 3 [80] to 5 [125], incl	100 [690]	50 [345]	10
O32	hot extruded and temper annealed				
O26	hot rolled and temper annealed				
Copper Alloy UNS No C63020					
TQ30	quenched hardened and tempered	rod and bar: up to 1 [25] incl over 1 [25] to 2 [50], incl over 2 [50] to 4 [100], incl	135 [930] 130 [890] 130 [890]	100 [690] <sup>C</sup> 95 [650] <sup>C</sup> 90 [620] <sup>C</sup>	6 6 6
Copper Alloy UNS No. C63200					
TQ50	quench hardened and temper annealed	rod and bar: up to 3 [80], incl over 3 [80] to 5 [125], incl over 5 [125] to 12 [300], incl	90 [620] 90 [620] 90 [620]	50 [345] 45 [310] 40 [275]	15 15 15
TQ55	quench hardened, temper annealed, drawn, and stress relieved				
O20	hot forged and annealed				
O25	hot rolled and annealed	bar and shapes all sizes	90 [620]	40 [275]	15
Copper Alloy UNS Nos. C64200 and C64210					
HR50	drawn and stress relieved	rod and bar: ½ [12] and under over ½ [12] to 1 [25], incl over 1 [25] to 2 [50], incl over 2 [50] to 3 [80], incl	90 [620] 85 [585] 80 [550] 75 [515]	45 [310] 45 [310] 42 [290] 35 [240]	9 12 12 15

TABLE 2 Continued

Temper Designation		Diameter or Distance Between Parallel Surfaces, <sup>A</sup> in. [mm]	Tensile Strength, min ksi [MPa]	Yield Strength, min ksi [MPa], at 0.5 % Extension Under Load	Elongation in 4 x Diameter or Thickness of Specimen min, % <sup>B</sup>
Code	Name				
M10	as hot forged—air cooled	over 3 [80] to 4 [100] incl over 4 [100]	70 [485]	30 [205]	15
M20	as hot rolled				
M30	as hot extruded				
M30	as hot extruded	<i>shapes, all sizes</i>	70 [485]	30 [205]	15

<sup>A</sup> For rectangular bar, the Distance Between Parallel Surfaces as used in this table refers to the thickness.

<sup>B</sup> Elongation values are based on 5.65 times the square root of the area for dimensions greater than 0.10 in. [2.5 mm]. In any case, a minimum gage length of 1 in. [25 mm] shall be used.

<sup>C</sup> Yield strength at 0.2 % offset.

TABLE 3 Rockwell Hardness Requirements<sup>A</sup>

Temper Designation		Diameter or Distance Between Parallel Surfaces, in. [mm]	Rockwell Hardness Determined on the Cross Section Midway Between Surface and Center
Code	Name		
Copper Alloy UNS No. C63020			
TQ30	Quench hardened and tempered	all sizes	C26 min
Copper Alloys UNS Designations C64200 and C64210			
HR50	drawn and stress relieved	0.5 [12] to 1.0 [25], incl. over 1.0 [25] to 2.0 [50], incl. over 2.0 [50] to 3.0 [80], incl.	B80 – 100 B80 – 100 B70 – 95
M30	as hot-extruded	over 3.0 [80] to 4.0 [100], incl. over 4.0 [100] <i>shapes, all sizes</i>	B65 – 95 B65 – 95 B65–95

<sup>A</sup> Rockwell hardness requirements are not established for diameters less than 0.5 in. [12 mm].

6.2.1 When all elements in Table 1 are determined, the sum of results shall be 99.5 % minimum for all alloys except C61300 which shall be 99.8 % min.

6.3 These composition limits do not preclude the presence of other elements. By agreement between the manufacturer and the purchaser, limits may be established and analysis required for unnamed elements.

## 7. Temper

7.1 The standard tempers for products described in this specification, and as defined in Classification B601, are given in Tables 2 and 3.

7.1.1 Annealed tempers O20, O25, and O30.

7.1.2 Cold worked and stress relieved temper HR50.

7.1.3 As-manufactured tempers M10, M20, M30.

7.1.4 Heat treated tempers O26, O32, TQ30, TQ50 and TQ55.

NOTE 3—UNS No. C63000 has two available strength levels available in rod, standard strength and high strength.

## 8. Mechanical Property Requirements

8.1 Product furnished under this specification shall conform to the mechanical property requirements prescribed in Table 2 and Table 3 for the Copper Alloy UNS No. designation specified in the ordering information.

8.2 *Rockwell Hardness Requirement*—For the alloys and tempers listed in Table 3, product 0.5 in. [12 mm] and over in diameter or distance between parallel surfaces shall conform

with the requirements prescribed in Table 3, when tested in accordance with Test Methods E18.

### 8.2.1 DELETED

8.3 *Tensile Strength Requirements*—Product furnished under this specification shall conform to the tensile requirements in Table 2 when tested in accordance with Test Methods E8/E8M.

## 9. Performance Requirements

### 9.1 Residual Stress Test:

9.1.1 When specified in the contract or purchase order, the product shall be tested for residual stress according to the requirements of Test Method B154 or Test Method B858, and show no signs of cracking.

**Warning**—Mercury is a definite health hazard. With the Mercurous Nitrate Test, equipment for the detection and removal of mercury vapor produced in volatilization, and the use of protective gloves is recommended.

9.1.2 When the ammonia vapor test is used, the test pH value appropriate for the intended application shall be 10 unless otherwise specified by the purchaser.

NOTE 4—A residual stress test provides information about the adequacy of the stress relief of the material. Bar straightening is a method of mechanical stress relief. Stress relief annealing is a method of thermal stress relief.

9.2 *Piston Finish*—When specified, round rod over 0.5 in. [12 mm] in diameter shall be furnished piston finished. Refer to Specification B249/B249M.

## 10. Dimensions and Permissible Variations

10.1 The dimensions and tolerances for product described by this specification shall be as specified in Specification B249/B249M with particular reference to the following tables and related paragraphs:

10.1.1 *Diameter or Distance between Parallel Surfaces, Rod (Round, Hexagonal, Octagonal)*:

10.1.1.1 *Rod: Cold Drawn Tempers*—Refer to applicable Table 2 on Tolerances for Diameter or Distances Between Parallel Surfaces of Cold-Drawn Rod.

10.1.1.2 *Rod, M30, O30, and O32 tempers*—Refer to Table 4 on Tolerances for Diameter or Distance Between Parallel Surfaces of As-Extruded Rod and Bar.

10.1.1.3 *Round Rod, M20 temper*—Refer to Table 6 on Diameter Tolerances for Hot-Rolled Round Rod.

10.1.1.4 *Piston Finish Rod*—Refer to Table 3 on Diameter Tolerances for Piston-Finished Rod.

10.1.2 *Distance between Parallel Surfaces, Bar (Rectangular and Square)*:

10.1.2.1 *Bar, Drawn Tempers*—Refer to Table 9 on Thickness Tolerances for Rectangular and Square Bar, and Table 11 on Width Tolerances for Rectangular Bar.

10.1.2.2 *Bar, M30, O30, and O32 Tempers*—Refer to Table 4 on Tolerances for Diameter or Distance Between Parallel Surfaces of As-Extruded Rod and Bar.

10.1.3 *Length of Rod, Bar and Shapes*—Refer to Table 13 on Length Tolerances for Rod, Bar, and Shapes, and Table 15 on Schedule of Lengths (Specific and Stock) with Ends for Rod and Bar.

10.1.4 *Straightness*:

10.1.4.1 *Rod and Bar*—Refer to Table 16 on Straightness Tolerances for Rod, Bar, and Shapes.

10.1.4.2 *Shafting Rod*—Refer to Table 17 on Straightness Tolerances for Shafting.

10.1.4.3 *Rod, Bar and Shapes of M20, M30, O30, and O32 Temper*—They shall be of sufficient straightness to meet the requirements of the intended application.

10.1.5 *Edge Contours*—Refer to section entitled, “Edge Contours.”

10.2 *Shapes*—The cross section dimensional tolerances for shapes shall be as agreed upon between the manufacturer and the purchaser.

## 11. Workmanship, Finish, and Appearance

11.1 When specified in the contract or purchase order, round rod over ½ in. [12 mm] in diameter shall be furnished as piston finish rod or shafting.

## 12. Test Methods

12.1 *Chemical Analysis*:

12.1.1 In cases of disagreement, determine the composition using the following methods:

Element	ASTM Test Methods
Aluminum	E478, Titrimetric
Arsenic	E62
Copper	E478
Iron	E478, Photometric
Lead	E478, Atomic absorption
Manganese	E62
Nickel	E478, Photometric
Phosphorous	E62
Silicon	E62
Tin	E478, Photometric
Zinc	E478, Atomic absorption
Cadmium	E53
Chromium	E118

12.1.2 Test methods to be followed for the determination of elements resulting from contractual or purchase order agreement shall be as agreed upon between the manufacturer or supplier and the purchaser.

## 13. Keywords

13.1 aluminum bronze bar; aluminum bronze rod; aluminum bronze shapes; UNS Alloy No. C61300; UNS Alloy No. C61400; UNS Alloy No. C61900; UNS Alloy No. C62300; UNS Alloy No. C62400; UNS Alloy No. C63000; UNS Alloy No. C63020; UNS Alloy No. C63200; UNS Alloy No. C64200; UNS Alloy No. C64210

ASMENORMDOC.COM : Click to view the full PDF of ASME BPVC.II.B (ASME BPVC Section II part B) 2025

INTENTIONALLY LEFT BLANK

# SPECIFICATION FOR COPPER-NICKEL-ZINC ALLOY (NICKEL SILVER) AND COPPER-NICKEL ROD AND BAR



**SB-151/SB-151M**

(Identical with ASTM Specification B151/B151M-20 except paras. 5.2.2 and 5.2.3 have been deleted.)

# Specification for Copper-Nickel-Zinc Alloy (Nickel Silver) and Copper-Nickel Rod and Bar

## 1. Scope

1.1 This specification establishes the requirements for copper-nickel-zinc and copper-nickel rod and bar for general application produced from Copper Alloy UNS Nos. C70600, C70620, C71500, C71520, C74500, C75200, C75700, C76400, C77000, and C79200.

1.1.1 Copper Alloys UNS Nos. C70620 and C71520 are for product intended for welding applications.

1.1.2 *Units*—The values stated in either inch-pound units or SI units are to be regarded separately as standard. Within the text, SI units are shown in brackets. The values stated in each system are not necessarily exact equivalents; therefore, to ensure conformance with the standard, each system shall be used independently of the other, and values from the two systems shall not be combined.

NOTE 1—Requirements for copper-nickel-zinc alloy wire appear in Specification B206/B206M.

1.2 *This international standard was developed in accordance with internationally recognized principles on standardization established in the Decision on Principles for the Development of International Standards, Guides and Recommendations issued by the World Trade Organization Technical Barriers to Trade (TBT) Committee.*

## 2. Referenced Documents

### 2.1 ASTM Standards:

B206/B206M Specification for Copper-Nickel-Zinc (Nickel Silver) Wire and Copper-Nickel Alloy Wire  
B249/B249M Specification for General Requirements for Wrought Copper and Copper-Alloy Rod, Bar, Shapes and Forgings  
B601 Classification for Temper Designations for Copper and Copper Alloys—Wrought and Cast  
B846 Terminology for Copper and Copper Alloys  
B950 Guide for Editorial Procedures and Form of Product Specifications for Copper and Copper Alloys  
E75 Test Methods for Chemical Analysis of Copper-Nickel and Copper-Nickel-Zinc Alloys (Withdrawn 2010)  
E76 Test Methods for Chemical Analysis of Nickel-Copper Alloys (Withdrawn 2003)  
E478 Test Methods for Chemical Analysis of Copper Alloys

## 3. General Requirements

3.1 The following sections of Specification B249/B249M constitute a part of this specification:

- 3.1.1 Terminology;
- 3.1.2 Material and Manufacture;
- 3.1.3 Workmanship, Finish, and Appearance;
- 3.1.4 Sampling;
- 3.1.5 Number of Tests and Retests;
- 3.1.6 Specimen Preparation;
- 3.1.7 Test Methods;
- 3.1.8 Significance of Numerical Limits;
- 3.1.9 Inspection;
- 3.1.10 Rejection and Rehearing;
- 3.1.11 Certification;
- 3.1.12 Report;
- 3.1.13 Packaging and Package Marking; and
- 3.1.14 Supplementary Requirements.

3.2 In addition, when a section with a title identical to that referenced in 3.1, above, appears in this specification, it contains additional requirements which supplement those appearing in Specification B249/B249M.

## 4. Terminology

4.1 For definitions of terms related to copper and copper alloys, refer to Terminology B846.

## 5. Ordering Information

5.1 Include the following specified choices when placing orders for product under this specification, as applicable:

- 5.1.1 ASTM designation and year of issue;
- 5.1.2 Copper Alloy UNS No. designation (Section 1);
- 5.1.3 Temper (Section 8 and Tables 2-6);
- 5.1.4 Form: cross section such as round, hexagonal, square, and so forth (Section 11);
- 5.1.5 Diameter or distance between parallel surfaces, length (Section 11);
- 5.1.6 Weight: total for each form, size, and temper; and
- 5.1.7 Intended application.

5.2 The following options are available but may not be included unless specified at the time of placing of the order when required:

5.2.1 Heat identification or traceability details (4.1 of Specification B249/B249M),

5.2.2 DELETED

5.2.3 DELETED

5.2.4 When material is purchased for agencies of the U.S. Government (Section 11).

## 6. Materials and Manufacture

### 6.1 Material:

6.1.1 The material of manufacture as specified in the contract or purchase order, shall be of one of Copper Alloy UNS Nos. C70600, C70620, C71500, C71520, C74500, C75200, C75700, C76400, C77000, or C79200.

## 7. Chemical Composition

7.1 The material shall conform to the chemical composition requirements in Table 1 for the Copper Alloy UNS No. designation specified in the ordering information.

7.1.1 These composition limits do not preclude the presence of other elements. By agreement between the manufacturer and the purchaser, limits may be established and analysis required for unnamed elements.

7.2 For alloys in which copper is listed as “remainder,” copper is the difference between the sum of results for all elements determined and 100 %.

7.3 For alloys in which zinc is listed as “remainder,” either copper or zinc may be taken as the difference between the sum of all elements determined and 100 %.

7.4 When all elements listed in Table 1 for a specified alloy are determined, the sum of results shall be 99.5 % minimum.

**TABLE 2 Grain Size Requirements for OS (Annealed) Temper Rod and Bar**

Copper Alloy UNS No.	Temper Designation	Grain Size, mm		
		Nominal	Minimum	Maximum
All alloys	OS015	0.015	...	0.030
All alloys	OS035	0.035	0.025	0.050
C74500, C75200, C75700, C76400, and C77000	OS070	0.070	0.050	0.100

**TABLE 3 Tensile Requirements for Copper-Nickel-Zinc Alloy Rod and Bar (Inch-Pound Units)**

NOTE 1—SI values are stated in Table 4.

Temper Designation	Diameter or Distance Between Parallel Surfaces, in.	Tensile Strength, ksi			
		Copper Alloy UNS Nos. C75200 and C79200		Copper Alloy UNS Nos. C74500, C75700, C76400, and C77000	
		Min	Max	Min	Max
H01	Rod: round	60	80	75	95
	0.02 to 0.50, incl				
H04	Rod: round, hexagonal, octagonal	80	100	90	110
	0.02 to 0.25, incl				
	Over 0.25 to 0.50, incl				
	Over 0.50 to 1.0, incl				
H04	Bar: square, rectangular	60	80	70	90
	all sizes				
	68				

## 8. Temper

8.1 The standard tempers for products described in this specification and as defined in Classification B601 are: O60, OS015, OS035, OS070, M30, H01, and H04 as given in Tables 2-6.

NOTE 2—The purchaser should confer with the manufacturer or supplier concerning the availability of a specific form and temper.

8.2 Other tempers, and tempers for other products, including shapes, shall be subject to agreement between the manufacturer and the purchaser.

**TABLE 1 Chemical Requirements**

Copper Alloy UNS No.	Composition, % max (unless shown as range or min)								
	Copper, Incl Silver	Nickel, Incl Cobalt	Lead	Iron	Manganese	Zinc	Phosphorous	Sulfur	Carbon
C70600	remainder	9.0-11.0	0.05	1.0-1.8	1.0	1.0	...	...	...
C70620	86.5 min	9.0-11.0	0.02	1.0-1.8	1.0	0.50	0.02	0.02	0.05
C71500	remainder	29.0-33.0	0.05	0.40-1.0	1.0	1.0	...	...	...
C71520	65.0 min	29.0-33.0	0.02	0.40-1.0	1.0	0.50	0.02	0.02	0.05
C74500	63.5-66.5	9.0-11.0	0.05	0.25	0.50	remainder	...	...	...
C75200	63.0-66.5	16.5-19.5	0.05	0.25	0.50	remainder	...	...	...
C75700	63.5-66.5	11.0-13.0	0.05	0.25	0.50	remainder	...	...	...
C76400	58.5-61.5	16.5-19.5	0.05	0.25	0.50	remainder	...	...	...
C77000	53.5-56.5	16.5-19.5	0.05	0.25	0.50	remainder	...	...	...
C79200	59.0-66.5	11.0-13.0	0.8-1.4	0.25	0.50	remainder	...	...	...

**TABLE 4 Tensile Requirements for Copper-Nickel-Zinc Alloy Rod and Bar [SI Units]**

NOTE 1—Inch-Pound values are stated in Table 3.

Temper Designation	Diameter or Distance Between Parallel Surfaces, mm	Tensile Strength, MPa			
		Copper Alloy UNS Nos. C75200 and C79200		Copper Alloy UNS Nos. C74500, C75700, C76400 and C77000	
		Min	Max	Min	Max
H01	Rod: round	415	550	515	655
	0.5 to 10, incl				
H04	Rod: round, hexagonal	550	690	620	760
	0.5 to 6.5 incl				
	Over 6.5 to 10, incl				
	Over 10 to 25, incl				
	Over 25				
H04	Bar: square, rectangular all sizes	470	605	515	650

## 9. Grain Size of Annealed Tempers

9.1 Grain size shall be the standard requirement for all product in the annealed tempers.

9.1.1 Product in the OS temper shall conform to the grain size requirement prescribed in Table 2 for the specified copper alloy and temper.

9.1.2 Grain size shall be the basis for acceptance or rejection for OS temper product produced from Copper Alloy UNS Nos. C74500, C75200, C75700, C76400, C77000, and C79200.

## 10. Mechanical Property Requirements

### 10.1 Tensile Strength Requirement:

10.1.1 Product of Copper-Nickel-Zinc Alloys UNS Nos. C74500, C75200, C75700, C76400, C77000, and C79200 in Tempers H01 and H04 furnished under this specification shall conform to the tensile requirements prescribed in Tables 3 and 4 for the specified shape and size. The tensile strength shall be the basis of acceptance or rejection for product in these tempers.

10.1.2 Product of Copper-Nickel Alloys UNS Nos. C70600, C70620, C71500, and C71520 in Tempers H01, H04, M30, and O60 furnished under this specification shall conform to the tensile requirements prescribed in Tables 5 and 6 for the specified shape and size. The tensile properties shall be the basis of acceptance or rejection for all tempers.

## 11. Purchases for U.S. Government Agencies

11.1 When specified in the contract or purchase order, product purchased for agencies of the U.S. Government shall conform to the special government regulations specified in the Supplementary Requirements section of Specification B249/B249M.

## 12. Dimensions, Mass, and Permissible Variations

12.1 The dimensions and tolerances for product described by this specification shall be as specified in Specification B249/B249M with particular reference to the following tables and related paragraphs:

### 12.1.1 Diameter or Distance Between Parallel Surfaces:

12.1.1.1 Rod: round/hexagonal, octagonal—cold-drawn rod, Table 2.

12.1.1.2 Bar: rectangular and square—thickness, width, Tables 9 and 11.

12.1.2 Length—length tolerances, schedule of length, Tables 13 and 15.

12.1.3 Straightness tolerances for rod, bar, and shapes, Table 16.

12.1.4 Edge contours—see identically titled section.

## 13. Test Methods

13.1 The test methods used for quality control or production control, or both, for the determination of conformance with product property requirements are discretionary.

13.1.1 The test methods used to obtain data for the preparation of certification or test report, or both, shall be made available to the purchaser on request.

13.2 *Chemical Analysis*—In cases of disagreement, test methods for chemical analysis shall be subject to agreement between the manufacturer or supplier and the purchaser. The following table is a list of published test methods some of which are considered by ASTM as no longer viable. These, and others not listed, may be used, subject to agreement.

Element	Range, %	Method
Copper	53–90	E478
Iron	0.02–8	E75
Lead	0.05–1.5	E478 (AA)
Manganese	0.05–1.0	E75
Nickel	8–34	E478 (Gravimetric)
Zinc	0–1.0	E478 (AA)
Zinc	2–40	E478 (Titrimetric)
Sulfur	0–0.1	E478 (AA)
Phosphorus	0–1.0	E478 (AA)
Carbon	0.01–1.0	E76

## 14. Keywords

14.1 copper alloy bar; copper alloy rod; copper-nickel alloy bar; copper-nickel alloy rod; copper-nickel-zinc alloy bar; copper-nickel-zinc alloy rod; cupronickel bar; cupronickel rod; nickel silver bar; nickel silver rod; UNS C70600 bar; UNS C71500 bar; UNS C74500 bar; UNS C75200 bar; UNS C75700 bar; UNS C76400 bar; UNS C77000 bar; UNS C79200 bar; UNS C70600 rod; UNS C71500 rod; UNS C74500 rod; UNS C75200 rod; UNS C75700 rod; UNS C76400 rod; UNS C77000 rod; UNS C79200 rod ; UNS C70620; UNS C71520

TABLE 5 Tensile Requirements for Copper-Nickel Alloy Rod and Bar (Inch-Pound Units)

NOTE 1—SI values are stated in Table 6.

Temper Designation	Diameter or Distance Between Parallel Surfaces, in.		Tensile Strength, min, ksi	Yield Strength at 0.5 % Extension Under Load, min, ksi	Elongation in 4x Diameter or Thickness of Specimen, min, % <sup>A</sup>
Copper Alloy UNS Nos. C70600 and C70620					
O60, M30	round, hexagonal, and octagonal rods and square bars	all sizes	38	15	30
H04	round, hexagonal, and octagonal rods and square bars	up to $\frac{3}{8}$ , incl	60	38	10
		over $\frac{3}{8}$ to 1, incl	50	30	15
		over 1 to 3, incl	40	15	30
		over 3 to 5, incl	38	15	20
O60	rectangular bars and shapes	all sizes	38	15	30
H04	rectangular bars	For Thicknesses			
		up to $\frac{3}{8}$ , incl	55	30	10
		over $\frac{3}{8}$ to $\frac{1}{2}$ incl	50	28	12
H04	shapes	over $\frac{1}{2}$ to 3	40	17	20
		all sizes	(As agreed upon between the manufacturer or supplier and the purchaser)		
Copper Alloy UNS Nos. C71500 and C71520					
O60, M30	round, hexagonal, and octagonal rods and square bars	up to $\frac{1}{2}$ , incl	52	18	30
		over $\frac{1}{2}$ to 1, incl	48	18	30
H01	round, hexagonal, and octagonal rods and square bars	over 1	45	18	30
		up to $\frac{1}{2}$ , incl	65	50	10
		over $\frac{1}{2}$ to 1, incl	60	45	15
H04		over 1 to 3, incl	55	35	20
		over 3 to 5, incl	45	18	20
		up to $\frac{1}{2}$ , incl	80	60	8
		over $\frac{1}{2}$ to 1, incl	75	58	10
O60	rectangular bars and shapes	over 1 to 2, incl	70	55	10
		all sizes	45	15	30
H04	rectangular bars	For Thicknesses			
		up to $\frac{1}{2}$ , incl	75	55	7
H04	shapes	over $\frac{1}{2}$ to 1, incl	70	50	10
		all sizes	(As agreed upon between the manufacturer or supplier and the purchaser)		

<sup>A</sup> In any case, a minimum gage length of 1 in. shall be used.

**TABLE 6 Tensile Requirements for Copper-Nickel Alloy Rod and Bar [SI Units]**

NOTE 1—Inch-pound values are stated in Table 5.

Temper Designation	Diameter or Distance Between Parallel Surfaces, mm		Tensile Strength, min, MPa	Yield Strength at 0.5 % Extension Under Load, min, MPa	Elongation in 4x Diameter or Thickness of Specimen, min, % <sup>A</sup>
Copper Alloy UNS Nos. C70600 and C70620					
O60, M30	round, hexagonal, and octagonal rods and square bars	all sizes	260	105	30
H04	round, hexagonal, and octagonal rods and square bars	up to 9.5, incl	415	260	10
		over 9.5 to 25, incl	345	205	15
		over 25 to 80, incl	275	105	30
		over 80 to 125, incl	260	105	20
O60	rectangular bars and shapes	all sizes	260	105	30
H04	rectangular bars	For Thicknesses			
		up to 9.5, incl	380	205	10
		over 9.5 to 12, incl	345	195	12
H04	shapes	over 12 to 80, incl	275	115	20
		all sizes	(As agreed upon between the manufacturer or supplier and the purchaser)		
Copper Alloy UNS Nos. C71500 and C71520					
O60, M30	round, hexagonal, and octagonal rods and square bars	up to 12, incl	360	125	30
		over 12 to 25, incl	330	125	30
		over 25	310	125	30
H01	round, hexagonal, and octagonal rods and square bars	up to 12, incl	450	345	10
		over 12 to 25, incl	415	310	15
		over 25 to 80, incl	380	240	20
		over 80 to 125, incl	310	125	20
H04		up to 12, incl	550	415	8
		over 12 to 25, incl	515	400	10
		over 25 to 50, incl	485	380	10
O60	rectangular bars and shapes	all sizes	310	105	30
H04	rectangular bars	For Thicknesses			
		up to 12, incl	515	380	7
H04	shapes	over 12 to 25, incl	485	345	10
		all sizes	(As agreed upon between the manufacturer or supplier and the purchaser)		

<sup>A</sup> In any case, a minimum gage length of 25 mm shall be used.

# SPECIFICATION FOR COPPER SHEET, STRIP, PLATE, AND ROLLED BAR



**SB-152/SB-152M**

(Identical with ASTM Specification B152/B152M-19 except for the deletion of paras. 7.3.1.1 and 10.3.1, and certification and test reports have been made mandatory.)

# Specification for Copper Sheet, Strip, Plate, and Rolled Bar

## 1. Scope

1.1 This specification establishes the requirements for copper sheet, strip, plate, and rolled bar produced from the following coppers.

Copper UNS No. <sup>A</sup>	Previous Designation	Type of Copper
C10100 <sup>B</sup>	OFE	Oxygen-free electronic
C10200 <sup>B</sup>	OF	Oxygen-free without residual deoxidants
C10300	OFXLP	Oxygen-free extra low phosphorus
C10400, C10500, C10700	OFS	Oxygen-free, silver bearing
C10800	OFLP	Oxygen-free low phosphorus
C10910	...	Low oxygen
C11000 <sup>B, C</sup>	ETP, TP <sup>C</sup>	Electrolytic tough pitch, <sup>C</sup> Tough pitch <sup>C</sup>
C11300, C11400, C11600 <sup>B</sup>	STP	Silver bearing tough pitch
C12000	DLP	Phosphorized, low residual phosphorus
C12200 <sup>B</sup>	DHP	Phosphorized, high residual phosphorus
C12300	DHPS	Phosphorized, silver bearing
C14200	DPA	Phosphorus deoxidized, arsenical
C14420	...	Tin bearing tellurium copper
C14530	...	Tin tellurium bearing copper

<sup>A</sup> Except Copper UNS Nos. C10910 (low oxygen), C14200 (phosphorus deoxidized, arsenical), C14420 (tin bearing tellurium), and C14530 (tin tellurium bearing) these types of copper are classified in Classification B224.

<sup>B</sup> SAE Specification CA101 conforms to Copper UNS No. C10100; SAE Specification CA102 conforms to the requirements for Copper UNS No. C10200; SAE Specification CA110 conforms to the requirements for Copper UNS No. C11000; SAE Specifications CA113, CA114, and CA116 conform to the requirements for Copper UNS Nos. C11300, C11400, and C11600; SAE Specification CA120 conforms to Copper UNS No. C12000; and SAE Specification CA122 conforms to the requirements for Copper UNS No. C12200.

<sup>C</sup> Unless specified in the contract or purchase order the supplier is permitted to provide ETP copper or TP copper.

NOTE 1—Each of the coppers listed has unique properties that can make it suitable for specific applications. The purchaser should consult with the supplier to determine which copper would be best suited for the intended application.

NOTE 2—This specification is not intended to establish requirements for material rolled to ounce-weight thicknesses. Such material is defined in Specification B370.

Flat copper products with finished (rolled or drawn) edges (flat wire and strip) are defined in Specification B272.

1.1.1 When a specific copper is not identified in the contract or purchase order, the supplier may furnish product from any of the listed coppers.

1.2 *Units*—The values stated in either inch-pound units or SI units are to be regarded separately as standard. The values stated in each system are not necessarily exact equivalents; therefore, to ensure conformance with the standard, each system shall be used independently of the other and values from the two systems shall not be combined.

1.3 The following safety hazard caveat pertains only to the test method(s) described in this specification:

1.3.1 *This standard does not purport to address all of the safety concerns, if any, associated with its use. It is the responsibility of the user of this standard to establish appropriate safety, health, and environmental practices and determine the applicability of regulatory limitations prior to use.*

1.4 *This international standard was developed in accordance with internationally recognized principles on standardization established in the Decision on Principles for the Development of International Standards, Guides and Recommendations issued by the World Trade Organization Technical Barriers to Trade (TBT) Committee.*

## 2. Referenced Documents

### 2.1 ASTM Standards:

- B170 Specification for Oxygen-Free Electrolytic Copper—Refinery Shapes
- B193 Test Method for Resistivity of Electrical Conductor Materials
- B216 Specification for Tough-Pitch Fire-Refined Copper—Refinery Shapes
- B224 Classification of Coppers

B248 Specification for General Requirements for Wrought Copper and Copper-Alloy Plate, Sheet, Strip, and Rolled Bar  
 B248M Specification for General Requirements for Wrought Copper and Copper-Alloy Plate, Sheet, Strip, and Rolled Bar (Metric)  
 B272 Specification for Copper Flat Products with Finished (Rolled or Drawn) Edges (Flat Wire and Strip)  
 B370 Specification for Copper Sheet and Strip for Building Construction  
 B577 Test Methods for Detection of Cuprous Oxide (Hydrogen Embrittlement Susceptibility) in Copper  
 B846 Terminology for Copper and Copper Alloys  
 E3 Guide for Preparation of Metallographic Specimens  
 E8/E8M Test Methods for Tension Testing of Metallic Materials  
 E53 Test Method for Determination of Copper in Unalloyed Copper by Gravimetry  
 E62 Test Methods for Chemical Analysis of Copper and Copper Alloys (Photometric Methods) (Withdrawn 2010)  
 E112 Test Methods for Determining Average Grain Size  
 E478 Test Methods for Chemical Analysis of Copper Alloys  
 2.2 ASME Standard:  
 ASME Boiler and Pressure Vessel Code

### 3. General Requirements

3.1 The following sections of Specification B248 or B248M constitute a part of this specification:

- 3.1.1 Terminology
- 3.1.2 Materials and Manufacture
- 3.1.3 Sampling
- 3.1.4 Number of Tests and Retests
- 3.1.5 Specimen Preparation
- 3.1.6 Test Methods
- 3.1.7 Packaging and Package Marking
- 3.1.8 Workmanship, Finish, and Appearance
- 3.1.9 Significance of Numerical Limits
- 3.1.10 Rejection and Reheating

3.2 In addition, when a section with a title identical to that referenced in 3.1, above, appears in this specification, it contains additional requirements which supplement those appearing in Specification B248 or B248M.

### 4. Terminology

4.1 *Definitions*—For definitions of terms related to copper and copper alloys, refer to Terminology B846.

### 5. Ordering Information

5.1 Include the following specified choices when placing orders for product under this specification, as applicable:

- 5.1.1 ASTM designation and year of issue;
  - 5.1.2 Copper [Alloy] UNS No. (or other internationally recognized copper [alloy]). With Alloys C10400, C10500, C10700, C11300, C11400, C11600, or C12300, the amount of silver in ounces per ton;
  - 5.1.3 Temper (Section 7);
  - 5.1.4 Dimensions: thickness, width, and edges (Section 12);
  - 5.1.5 How furnished: straight lengths or coils;
  - 5.1.6 Quantity – total weight or total length or number of pieces of each size;
  - 5.1.7 Length (Section 12); and
  - 5.1.8 Weight of coils: coil weights or coil size limitations, if required.
- 5.2 The following options are available but may not be included unless specified at the time of placing of the order when required:
- 5.2.1 Embrittlement test for the alloys listed in 11.2.
  - 5.2.2 DELETED
  - 5.2.3 DELETED
  - 5.2.4 Resistivity test for alloys listed in Table 5 (see Section 9);
  - 5.2.5 If product is purchased for agencies of the U.S. Government (see the Supplemental Requirements section of Specifications B248 and B248M).

### 6. Chemical Composition

6.1 The materials shall conform to the chemical requirements in Table 1 for the copper [alloy] UNS No. specified in the ordering information.

6.2 These composition limits do not preclude the presence of other elements. By agreement between the manufacturer and purchaser, limits may be established and analysis required for unnamed elements.

### 7. Temper

7.1 The standard tempers for product described in this specification are given in Tables 2 and 3.

7.1.1 *As Hot Rolled Temper M20:*

7.1.1.1 Plate not specified for ASME Boiler and Pressure Vessel Code applications are generally available in the M20 temper.

7.1.2 *Cold Rolled Tempers H00 to H10.*

7.1.3 *Annealed Tempers O25, O60, or O68:*

7.1.3.1 DELETED

NOTE 3—Any product produced in a temper other than those listed in Table 2, Table 3, or Table 4 will be produced and sold by contract and cannot be said to be produced under this specification.

NOTE 4—Soft-anneal temper is suitable for most industrial users of copper such as forming, spinning, and simple drawing operations in which close control of temper is not essential. Deep drawing anneal temper is especially suited for very severe drawing and forming operations in which maximum ductility and close control of temper is required.

### 8. Grain Size for Cold Rolled Annealed Tempers

8.1 Grain size shall be standard requirement for all product of the annealed (O60 and O68) tempers.

TABLE 1 Chemical Requirements

Element	Composition,%																	
	Copper UNS No.																	
	C10100 <sup>A</sup>	C10200	C10300	C10400 <sup>B</sup>	C10500 <sup>B</sup>	C10700 <sup>B</sup>	C10800	C10910	C11000	C11300 <sup>C</sup>	C11400 <sup>C</sup>	C11600 <sup>C</sup>	C12000	C12200	C12300 <sup>D</sup>	C14200	C14420	C14530
Copper, min	99.99 <sup>E</sup>	99.95 <sup>E</sup> incl silver	99.95 <sup>F</sup> incl silver	99.95 <sup>E</sup> incl silver	99.95 <sup>E</sup> incl silver	99.95 <sup>E</sup> incl silver	99.95 <sup>F</sup> incl silver	99.95 incl silver	99.90 incl silver	99.90 incl silver	99.90 incl silver	99.90 incl silver	99.90 incl silver	99.9 incl silver	99.90 incl silver	99.4 incl silver	99.90 <sup>G</sup> incl silver	99.90 <sup>H</sup> incl silver
Phosphorus	<sup>A</sup>	...	0.001– 0.005	...	...	...	0.005– 0.012	...	...	...	...	...	0.004– 0.012	0.015– 0.040	0.015– 0.040	0.015– 0.040	...	0.001– 0.010
Arsenic	<sup>A</sup>	...	...	...	...	...	...	...	...	...	...	...	...	...	...	0.15– 0.50	...	...
Oxygen, max	0.0005	0.0010	...	0.0010	0.001	0.001	...	0.005	...	...	...	...	...	...	...	...	...	...
Silver	<sup>A</sup>	...	...	8 <sup>I</sup>	10 <sup>I</sup>	25 <sup>I</sup>	...	...	...	8 <sup>I</sup>	10 <sup>I</sup>	25 <sup>I</sup>	...	...	4 <sup>I</sup>	...	...	...
Selenium + tellurium, max	<sup>A</sup>	...	...	...	...	...	...	...	...	...	...	...	...	...	...	...	...	0.023
Tellurium	<sup>A</sup>	...	...	...	...	...	...	...	...	...	...	...	...	...	...	...	0.005– 0.05	0.003– 0.023 <sup>J</sup>
Tin	<sup>A</sup>	...	...	...	...	...	...	...	...	...	...	...	...	...	...	...	0.04– 0.15	0.003– 0.023

<sup>A</sup> Impurity maximums in ppm of C10100 shall be: antimony 4, arsenic 5, bismuth 1, cadmium 1, iron 10, lead 5, manganese 0.5, nickel 10, phosphorus 3, selenium 3, silver 25, sulfur 15, tellurium 2, tin 2, and zinc 1.

<sup>B</sup> C10400, C10500, and C10700 are oxygen-free coppers with the addition of a specified amount of silver. The compositions of these alloys are equivalent to C10200 plus the intentional addition of silver.

<sup>C</sup> C11300, C11400, and C11600 are electrolytic tough-pitch copper with silver additions. The compositions of these alloys are equivalent to C11000 plus the intentional addition of silver.

<sup>D</sup> Copper UNS No. C12300 is produced by the addition of silver to phosphorus-deoxidized copper.

<sup>E</sup> Copper shall be determined by difference between impurity total and 100 %.

<sup>F</sup> Includes phosphorus.

<sup>G</sup> Includes tellurium + tin.

<sup>H</sup> Includes tin + tellurium + selenium.

<sup>I</sup> Values are minimum silver Troy oz/Avoirdupois ton (1 oz/ton is equivalent to 0.0034 %).

<sup>J</sup> Tellurium or selenium, or both.

ASMENORMDOC.COM : Click to view the full PDF of ASME BPVC.II.B (ASME BPVC Section II part B) 2025

**TABLE 2 Tensile Strength Requirements and Approximate Hardness Values (Inch-Pound Units)**

Temper Designation		Tensile Strength, ksi <sup>A</sup>		Approximate Rockwell Hardness <sup>B</sup>	
Code	Name	Min	Max	F Scale	Superficial 30T
Cold-rolled tempers:					
H00	Eighth hard	32	40	54–82	up to 49
H01	Quarter hard	34	42	60–84	18–51
H02	Half hard	37	46	77–89	43–57
H03	Three-quarter-hard	41	50	82–91	47–59
H04	Hard	43	52	86–93	54–62
H06	Extra hard	47	56	88–95	56–64
H08	Spring	50	58	91–97	60–66
H10	Extra spring	52	...	92 and over	61 and over
Hot-rolled tempers:					
M20 <sup>C</sup>	Hot-rolled	30 <sup>E</sup>	38	up to 75	up to 41
O25 <sup>D</sup>	Hot-rolled and annealed	30 <sup>E</sup>	38	up to 65	up to 31

<sup>A</sup> ksi = 1000 psi.

<sup>B</sup> Rockwell values apply as follows: The F scale applies to metal 0.020 in. and over in thickness. The Superficial 30-T scale applies to metal 0.012 in. and over in thickness.

<sup>C</sup> See 7.1.1.1.

<sup>D</sup> DELETED

<sup>E</sup> The minimum yield strength at 0.5 % extension under load or at 0.2 % offset shall be 10 ksi.

**TABLE 3 Tensile Strength Requirements and Approximate Hardness Values (SI Units)**

Temper Designation		Tensile Strength, MPa		Approximate Rockwell Hardness <sup>A</sup>	
Code	Name	Min	Max	F Scale	Superficial 30T
Cold-rolled tempers:					
H00	Eighth hard	220	275	54–82	up to 49
H01	Quarter hard	235	290	60–84	18–51
H02	Half hard	255	315	77–89	43–57
H03	Three-quarter-hard	285	345	82–91	47–59
H04	Hard	295	360	86–93	54–62
H06	Extra hard	325	385	88–95	56–64
H08	Spring	345	400	91–97	60–66
H10	Extra spring	360	...	92 and over	61 and over
Hot-rolled tempers:					
M20 <sup>B</sup>	Hot-rolled	205 <sup>D</sup>	260	up to 75	up to 41
O25 <sup>C</sup>	Hot-rolled and annealed	205 <sup>D</sup>	260	up to 65	up to 31

<sup>A</sup> Rockwell values apply as follows: The F scale applies to metal 0.50 mm and over in thickness. The Superficial 30-T scale applies to metal 0.30 mm and over in thickness.

<sup>B</sup> See 7.1.1.1.

<sup>C</sup> DELETED

<sup>D</sup> The minimum yield strength at 0.5 % extension under load or at 0.2 % offset shall be 70 MPa.

**TABLE 4 Grain Size Requirements and Approximate Rockwell Hardness Values for Annealed Product**

Temper Designation		Grain Size, mm		Approximate Rockwell Hardness <sup>A</sup>	
Code	Name	Min	Max	F Scale	
				Min	Max
O60	Soft anneal	<sup>B</sup>			65
O68	Deep-drawing anneal	<sup>B</sup>	0.050	30	75

<sup>A</sup> Rockwell hardness values apply as follows: The F scale applies to metal 0.020 in. or 0.50 mm and over in thickness.

<sup>B</sup> Although no minimum grain size is required, this material must be fully recrystallized.

8.2 Acceptance or rejection based upon grain size shall depend only on the average grain size of a test specimen taken from each of two sample portions, and each specimen shall be within the limits prescribed in Table 4 when determined in accordance with Test Methods E112.

**TABLE 5 Electrical Mass Resistivity Requirements for Copper UNS Nos. C10100, C10200, C10300, C10400, C10500, C10700, C10910, C11000, C11300, C11400, and C11600**

Alloy	Tempers	Electrical Resistivity max, $\Omega \cdot \text{g}/\text{m}^2$
C10100	Annealed	0.15176
C10100	Cold Rolled	0.15614
C10200, C10300, C10400, C10500, C10700, C10910, C11000, C11300, C11400, C11600	Annealed	0.15328
C10200, C10300, C10400, C10500, C10700, C10910, C11000, C11300, C11400, C11600	Cold Rolled	0.15775

8.3 The test specimen shall be prepared in accordance with Guide E3. The average grain size shall be determined on a plane parallel to the surface of the product.

## 9. Physical Property Requirements

### 9.1 Electrical Resistivity Requirement:

9.1.1 When specified in the contract or purchase order on the alloys listed below, the product shall conform to the electrical mass resistivity requirement prescribed in Table 5, when tested in accordance with Test Method B193.

9.1.2 Copper UNS Nos. C10800, C12000, C12200, C12300, C14200, C14420, and C14530 when specified at the time of purchase for electrical conductor use shall meet resistivity requirements as agreed upon between the manufacturer or supplier and the purchaser.

NOTE 5—The International Annealed Copper Standard electrical conductivity equivalents are as follows:

Electrical Resistivity, $\Omega\text{-g/m}^2$	Conductivity, % IACS
0.151 76	101.00
0.153 28	100.00
0.156 14	98.16
0.157 75	97.16

## 10. Mechanical Property Requirements

10.1 *Tensile Requirements of As Hot-Rolled (M20), and Hot-Rolled and Annealed (O25) Tempers:*

10.1.1 Product furnished under this specification shall conform to the tensile strength requirements prescribed in Tables 2 and 3. Furthermore, Copper [Alloy] UNS Nos. C11000 and C12200 plate shall have 40 % minimum elongation in 2 in. [50 mm] and Copper [Alloy] UNS No. C14200 plate shall have 45 % minimum elongation in 2 in. [50 mm]. The test specimens shall be taken so that the longitudinal axis of the specimen is parallel to the direction of rolling and tested in accordance with Test Methods E8/E8M.

10.1.2 *Plate Item Test*—Five specimens shall be taken either from the excess portion of the plate or from separate pieces produced under the same specification and temper.

### 10.1.3 DELETED

### 10.2 Tensile Requirements of Rolled (R) Tempers:

10.2.1 Product furnished under this specification shall conform to the tensile strength requirements prescribed in Tables 2 and 3. The test specimens shall be taken so the longitudinal axis of the specimen is parallel to the direction of rolling and tested in accordance with Test Methods E8/E8M.

10.2.2 Acceptance or rejection based upon mechanical properties shall depend only on tensile strength.

### 10.3 Rockwell Hardness Requirement:

10.3.1 The approximate Rockwell hardness values given in Table 2, Table 3, and Table 4 are for general information and assistance in testing and shall not be used as a basis for product rejection.

NOTE 6—The Rockwell hardness tests offer a quick and convenient method of checking for general conformity to the specification requirements for temper, tensile strength, and grain size.

## 11. Performance Requirements

### 11.1 Microscopical Examination:

11.1.1 Samples of Copper [Alloy] UNS Nos. C10100, C10200, C10300, C10400, C10500, C10700, and C12000 shall be substantially free of cuprous oxide as determined by Procedure A of Test Methods B577. In case of a dispute, a referee method in accordance with Procedure C of Test Methods B577 shall be used.

11.1.2 When Copper UNS Nos. C10800, C10910, C11000, C11300, C11400, C11600, C12200, C12300, C14200, C14420, or C14530 are supplied, microscopical examination for cuprous oxide is not required.

11.2 *Hydrogen Embrittlement Susceptibility Test*—Samples of Copper UNS Nos. C10100, C10200, C10300, C10400, C10500, C10700, C10800, C12000, C12200, and C12300 shall be capable of passing the embrittlement test of Procedure B of Test Methods B577. The actual performance of this test is not mandatory under the terms of this specification unless specified in the ordering information. In case of a dispute, a referee method in accordance with Procedure C shall be used.

## 12. Dimensions, Mass, and Permissible Variation

12.1 The dimensions and tolerances for product described by this specification shall be as specified in Specification B248 or B248M with particular reference to the following tables and related paragraphs:

### 12.2 Thickness.

### 12.3 Width:

#### 12.3.1 Slit Metal and Slit Metal with Rolled Edges.

#### 12.3.2 Square Sheared Metal.

#### 12.3.3 Sawed Metal.

### 12.4 Length:

#### 12.4.1 Length Tolerance for Straight Lengths.

12.4.2 *Schedule for Minimum Lengths and Maximum Weights of Ends for Specific Lengths with Ends, and Stock Lengths with Ends.*

#### 12.4.3 Length Tolerance for Square Sheared Metal.

#### 12.4.4 Length Tolerance for Sawed Metal.

### 12.5 Straightness:

12.5.1 *Slit Metal or Slit Metal Either Straightened or Edge Rolled.*

#### 12.5.2 Square Sheared Metal.

#### 12.5.3 Sawed Metal.

### 12.6 Weight—Hot Rolled Sheet and Plate.

### 12.7 Edges Contours:

#### 12.7.1 Square Corners.

#### 12.7.2 Rounded Corners.

#### 12.7.3 Rounded Edges.

#### 12.7.4 Full-Rounded Edges.

## 13. Test Methods

### 13.1 Chemical Analyses:

13.1.1 In cases of disagreement, test methods for chemical analysis shall be subject to agreement between the manufacturer or supplier and the purchaser. The following table is a list

of published methods, some of which may no longer be viable, which along with others not listed, may be used subject to agreement.

Element	ASTM Test Method
Copper	E53
Phosphorus	E62
Selenium	Refer to Annex, Specification B216
Silver	E478
Tellurium	Refer to Annex, Specification B216
Arsenic	E62

13.1.2 Test method(s) to be followed for the determination of element(s) resulting from contractual or purchaser order agreement shall be as agreed upon between the manufacturer or supplier and purchaser.

13.1.3 For Copper [Alloy] UNS No. C10100, refer to the Annex of Specification B170 for test methods for chemical composition.

#### 13.2 Other Tests:

13.2.1 Refer to Specification B248 or B248M for the appropriate mechanical test method.

### 14. Inspection

14.1 The manufacturer or supplier shall inspect and make tests necessary to verify that the furnished product conforms to specification requirements.

14.2 When mutually agreed upon, the manufacturer or supplier and the purchaser shall conduct the final inspection simultaneously.

### 15. Certification

15.1 The purchaser shall be furnished certification that samples representing each lot have been tested and inspected as directed in this specification and requirements have been met.

15.2 DELETED

### 16. Test Report

16.1 A report of test results shall be furnished.

### 17. Keywords

17.1 annealed; copper bars; copper plate; copper sheet; copper strip; hot-rolled; rolled; UNS No. C10100; UNS No. C10200; UNS No. C10300; UNS No. C10400; UNS No. C10500; UNS No. C10700; UNS No. C10800; UNS No. C10910; UNS No. C11000; UNS No. C11300; UNS No. C11400; UNS No. C11600; UNS No. C12000; UNS No. C12200; UNS No. C12300; UNS No. C14200; UNS No. C14420; UNS No. C14530

ASMENORMDOC.COM : Click to view the full PDF of ASME BPVC.II.B (ASME BPVC Section II part B) 2025

INTENTIONALLY LEFT BLANK

## SPECIFICATION FOR NICKEL ROD AND BAR



**SB-160**

(Identical with ASTM Specification B160-05(2014) except that certification has been made mandatory and editorial correction to maximum carbon value for UNS N02200 in Table 2.)

ASMENORMDOC.COM : Click to view the full PDF of ASME BPVC.II.B (ASME BPVC Section II part B) 2025

# SPECIFICATION FOR NICKEL ROD AND BAR



SB-160

[Identical with ASTM Specification B 160-05(2014) except that certification has been made mandatory.]

## 1. Scope

**1.1** This specification covers nickel (UNS N02200), low carbon nickel (UNS N02201), and solution strengthened nickel (UNS N02211) in the form of hot-worked and cold-worked rod and bar in the conditions shown in Table 1.

**1.2** The values stated in inch-pound units are to be regarded as the standard. The values given in parentheses are for information only.

## 2. Referenced Documents

### 2.1 ASTM Standards:

- B 162 Specification for Nickel Plate, Sheet, and Strip
- B 880 Specification for General Requirements for Chemical Check Analysis of Nickel, Nickel Alloys, and Cobalt Alloys
- E 8 Test Methods for Tension Testing of Metallic Materials
- E 18 Test Methods for Rockwell Hardness and Rockwell Superficial Hardness of Metallic Materials
- E 29 Practice for Using Significant Digits in Test Data to Determine Conformance with Specifications
- E 140 Hardness Conversion Tables for Metals
- E 1473 Test Methods for Chemical Analysis of Nickel, Cobalt and High-Temperature Alloys

## 3. Terminology

### 3.1 Definitions of Terms Specific to This Standard:

**3.1.1** *bar, n* —material of rectangular (flats), hexagonal, or square solid section up to and including 10 in. (254 mm) in width and  $\frac{1}{8}$  in. (3.2 mm) and over in thickness in straight lengths.

NOTE 1 — Hot-worked rectangular bar in widths 10 in. (254 mm) and under may be furnished as hot-rolled plate with sheared or cut edges in accordance with Specification B 162, provided the mechanical property requirements of Specification B 160 are met.

**3.1.2** *rod, n* — material of round solid section furnished in straight lengths.

## 4. Ordering Information

**4.1** It is the responsibility of the purchaser to specify all requirements that are necessary for the safe and satisfactory performance of material ordered under this specification. Examples of such requirements include, but are not limited to, the following:

**4.1.1** ASTM designation and year of issue.

**4.1.2** UNS number.

**4.1.3** *Section* —Rod (round) or bar (square, hexagonal, or rectangular).

**4.1.4** *Dimensions* — Dimensions including length.

**4.1.5** Condition.

**4.1.6** Finish.

**4.1.7** *Quantity* — feet or number of pieces.

**4.1.8** *Certification* — Certification and a report of test results are required (Section 15).

**4.1.9** *Samples for Product (Check) Analysis* — State whether samples for product (check) analysis should be furnished.

**4.1.10** *Purchaser Inspection* — If purchaser wishes to witness tests or inspection of material at place of manufacture, the purchase order must so state indicating which test or inspections are to be witnessed.

## 5. Chemical Composition

**5.1** The material shall conform to the composition limits specified in Table 2.

**5.2** If a product (check) analysis is performed by the purchaser, the material shall be done per Specification B 880 and the material shall conform to the product (check) analysis variations defined in Check Analysis Variation table of Specification B 880.

TABLE 1  
MECHANICAL PROPERTIES

Condition and Diameter or Distance Between Parallel Surfaces, in. (mm)	Tensile Strength, min, psi (MPa)	Yield Strength (0.2% offset), min, psi (MPa) <sup>A</sup>	Elongation in 2 in. or 50 mm or 4D, min %
Nickel (UNS N02200)			
Cold-worked (as worked):			
Rounds, 1 (25.4) and under	80 000 (550)	60 000 (415)	10 <sup>B</sup>
Rounds over 1 to 4 (25.4 to 101.6) incl.	75 000 (515)	50 000 (345)	15
Squares, hexagons, and rectangles, all sizes	65 000 (450)	40 000 (275)	25 <sup>B</sup>
Hot-worked:			
All sections, all sizes	60 000 (415)	15 000 (105)	35 <sup>C</sup>
Rings and disks <sup>D</sup>	—	—	—
Annealed:			
Rods and bars, all sizes	55 000 (380)	15 000 (105)	40 <sup>B</sup>
Rings and disks <sup>E</sup>	—	—	—
Forging quality:			
All sizes	F	F	F
Low-Carbon Nickel (UNS N02201) and Solution Strengthened Nickel (UNS N02211)			
Hot-worked:			
All sections, all sizes	50 000 (345)	10 000 (70)	40 <sup>C</sup>
Annealed:			
All products, all sizes	50 000 (345)	10 000 (70)	40 <sup>B</sup>

<sup>A</sup> See 12.2.

<sup>B</sup> Not applicable to diameters or cross sections under  $\frac{3}{32}$  in. (2.4 mm).

<sup>C</sup> For hot-worked flats  $\frac{5}{16}$  in. (7.9 mm) and under in thickness the elongation shall be 25%, min.

<sup>D</sup> Hardness B 45 to B 80, or equivalent.

<sup>E</sup> Hardness B 45 to B 70 or equivalent.

<sup>F</sup> Forging quality is furnished to chemical requirements and surface inspection only. No tensile properties are required.

TABLE 2  
CHEMICAL REQUIREMENTS

Element	Composition Limits, %		
	Nickel (UNS N02200)	Low-Carbon Nickel (UNS N02201)	Solution Strengthened Nickel (UNS N02211)
Nickel, min <sup>A</sup>	99.0	99.0	93.7
Copper, max	0.25	0.25	0.25
Iron, max.	0.40	0.40	0.75
Manganese, max.	0.35	0.35	4.25–5.25
Carbon, max.	0.15	0.02	0.02
Silicon, max.	0.35	0.35	0.15
Sulfur, max.	0.01	0.01	0.015

<sup>A</sup> Element shall be determined arithmetically by difference.

## 6. Mechanical and Other Requirements

**6.1 Mechanical Properties** — The material shall conform to the mechanical properties specified in Table 1.

## 7. Dimensions and Permissible Variations

**7.1 Diameter, Thickness, or Width** — The permissible variations from the specified dimensions as measured on

the diameter or between parallel surfaces of cold-worked rod and bar shall be as prescribed in Table 3, and of hot-worked rod and bar as prescribed in Table 4.

**7.2 Out-of-Round** — Hot-worked rods and cold-worked rods (except “forging quality”), all sizes, in straight lengths, shall not be out-of-round by more than one half the total permissible variations in diameter shown in Tables 3 and 4, except for hot-worked rods  $\frac{1}{2}$  in. (12.7 mm) in diameter and under, which may be out-of-round by the total permissible variations in diameter shown in Table 4.

**7.3 Corners** — Cold-worked bars will have practically exact angles and sharp corners.

**7.4 Machining Allowances for Hot-Worked Materials** — When the surfaces of hot-worked products are to be machined, the allowances prescribed in Table 5 are recommended for normal machining operations.

**7.5 Length** — The permissible variations in length of cold-worked and hot-worked rod and bar shall be as prescribed in Table 6.

**7.5.1** Rods and bars ordered to random or nominal lengths will be furnished with either cropped or saw-cut

TABLE 3  
PERMISSIBLE VARIATIONS IN DIAMETER OR DISTANCE BETWEEN PARALLEL  
SURFACES OF COLD-WORKED ROD AND BAR

Specified Dimension, in. (mm) <sup>4</sup>	Permissible Variations from Specified Dimensions, in. (mm)	
	+	-
Rounds:		
$\frac{1}{16}$ (1.6) to $\frac{3}{16}$ (4.8), excl	0	0.002 (0.05)
$\frac{3}{16}$ (4.8) to $\frac{1}{2}$ (12.7), excl	0	0.003 (0.08)
$\frac{1}{2}$ (12.7) to $1\frac{5}{16}$ (23.8), incl	0.001 (0.03)	0.002 (0.05)
Over $1\frac{5}{16}$ (23.8) to $1\frac{15}{16}$ (49.2), incl	0.0015 (0.04)	0.003 (0.08)
Over $1\frac{15}{16}$ (49.2) to $2\frac{1}{2}$ (63.5), incl	0.002 (0.05)	0.004 (0.10)
Over $2\frac{1}{2}$ (63.5) to 3 (76.2), incl	0.0025 (0.06)	0.005 (0.13)
Over 3 (76.2) to 3 (88.9), incl	0.003 (0.08)	0.006 (0.15)
Over $3\frac{1}{2}$ (88.9) to 4 (101.6), incl	0.0035 (0.09)	0.007 (0.18)
Hexagons, squares, rectangles:		
$\frac{1}{2}$ (12.7) and less	0	0.004 (0.10)
Over $\frac{1}{2}$ (12.7) to $\frac{7}{8}$ (22.2), incl	0	0.005 (0.13)
Over $\frac{7}{8}$ (22.2) to $1\frac{1}{4}$ (31.8), incl	0	0.007 (0.18)
Over $1\frac{1}{4}$ (31.8) to $2\frac{1}{4}$ (57.2), incl	0	0.009 (0.23)
Over $2\frac{1}{4}$ (57.2) to 3 (76.2), incl	0	0.011 (0.28)
Over 3 (76.2) to $3\frac{1}{2}$ (88.9), incl	0	0.015 (0.38)
Over $3\frac{1}{2}$ (88.9) to 4 (101.6), incl	0	0.017 (0.43)

<sup>4</sup> Dimensions apply to diameter of rounds, to distance between parallel surfaces of hexagons and squares, and separately to width and thickness of rectangles.

TABLE 4  
PERMISSIBLE VARIATIONS IN DIAMETER OR DISTANCE BETWEEN  
PARALLEL SURFACES OF HOT-WORKED ROD AND BAR

Specified Dimension, in. (mm) <sup>4</sup>	Permissible Variations from Specified Dimensions, in. (mm)	
	+	-
Rod and bar, hot-worked:		
1 (25.4) and under	0.016 (0.41)	0.016 (0.41)
Over 1 (25.4) to 2 (50.8), incl	0.031 (0.79)	0.016 (0.41)
Over 2 (50.8) to 4 (101.6), incl	0.047 (1.19)	0.031 (0.79)
Over 4 (101.6)	0.125 (3.18)	0.063 (1.60)
Rod, rough-turned or rough-ground:		
Under 1 (25.4)	0.005 (0.13)	0.005 (0.13)
1 (25.4) and over	0.031 (0.79)	0
Forging quality rod: <sup>B</sup>		
Under 1 (25.4)	0.005 (0.13)	0.005 (0.13)
1 (25.4) and over	0.031 (0.79)	0

<sup>4</sup> Dimensions apply to diameter of rods, to distance between parallel surfaces of hexagons and squares, and separately to width and thickness of rectangles.

<sup>B</sup> Spot grinding is permitted to remove minor surface imperfections. The depth of these spot ground areas shall not exceed 3% of the diameter of the rod.

TABLE 5  
NORMAL MACHINING ALLOWANCES FOR HOT-WORKED MATERIAL

Finished-Machined Dimensions for Finishes as Indicated Below, in. (mm) <sup>A</sup>	Normal Machining Allowance, in. (mm)			
	On Diameter, for Rods	Distance Between Parallel Surface, for Hexagonal and Square Bar	For Rectangular Bar	
			On Thickness	On Width
Hot-worked: <sup>B</sup>				
Up to $\frac{7}{8}$ (22.2), incl	$\frac{1}{8}$ (3.2)	$\frac{1}{8}$ (3.2)	$\frac{1}{8}$ (3.2)	$\frac{3}{16}$ (4.8)
Over $\frac{7}{8}$ to $1\frac{7}{8}$ (22.2 to 47.6), incl	$\frac{1}{8}$ (3.2)	$\frac{3}{16}$ (4.8)	$\frac{1}{8}$ (3.2)	$\frac{3}{16}$ (4.8)
Over $1\frac{7}{8}$ to $2\frac{7}{8}$ (47.6 to 73.0), incl	$\frac{3}{16}$ (4.8)	$\frac{1}{4}$ (6.4)	...	$\frac{3}{16}$ (4.8)
Over $2\frac{7}{8}$ to $3\frac{13}{16}$ (73.0 to 96.8), incl	$\frac{1}{4}$ (6.4)	...	...	$\frac{3}{16}$ (4.8)
Over $3\frac{13}{16}$ (96.8)	$\frac{1}{4}$ (6.4)	...	...	$\frac{3}{8}$ (9.5)
Hot-worked rods:				
Rough-turned or Rough-ground: <sup>C</sup>				
$1\frac{5}{16}$ to 4 (23.8 to 101.6), incl in diameter	$\frac{1}{16}$ (1.6)	...	...	...
Over 4 to 12 (101.6 to 304.8), incl in diameter	$\frac{1}{8}$ (3.2)	...	...	...

<sup>A</sup> Dimensions apply to diameter of rods, to distance between parallel surfaces of hexagonal and square bar, and separately to width and thickness of rectangular bar.

<sup>B</sup> The allowances for hot-worked material in Table 5 are recommended for rods machined in lengths of 3 ft (0.91 m) or less and for bars machined in lengths of 2 ft (0.61 m) or less. Hot-worked material to be machined longer lengths should be specified showing the finished cross-sectional dimension and the length in which the material will be machined in order that the manufacturer may supply material with sufficient oversize, including allowance for out-of-straightness.

<sup>C</sup> Applicable to 3 ft (0.91 m) max length.

TABLE 6  
PERMISSIBLE VARIATIONS IN LENGTH OF RODS AND BARS

Random mill lengths:	
Hot-worked	6 to 24 ft (1.83 to 7.31 m) long with not more than 25 weight % between 6 and 9 ft (1.83 and 2.74 m) <sup>A</sup>
Cold-worked	6 to 20 ft (1.83 to 6.1 m) long with not more than 25 weight % between 6 and 10 ft (1.83 and 3.05 m).
Multiple lengths	Furnished in multiples of a specified unit length, within the length limits indicated above. For each multiple, an allowance of $\frac{1}{4}$ in. (6.4 mm) will be made for cutting, unless otherwise specified. At the manufacturer's option, individual specified unit lengths may be furnished.
Nominal lengths	Specified nominal lengths having a range of not less than 2 ft (610 mm) with no short lengths allowed. <sup>B</sup>
Cut lengths	A specified length to which all rods and bars will be cut with a permissible variation of $+\frac{1}{8}$ in. (3.2 mm), $-0$ for sizes 8 in. (203 mm) and less in diameter or distance between parallel surfaces. For larger sizes, the permissible variation shall be $+\frac{1}{4}$ in. (6.4 mm), $-0$ .

<sup>A</sup> For hot-worked sections weighing over 25 lb/ft (37 kg/m) and for smooth forged products, all sections, short lengths down to 2 ft (610 mm) may be furnished.

<sup>B</sup> For cold-worked rods and bars under  $\frac{1}{2}$  in. (12.7 mm) in diameter or distance between parallel surfaces ordered to nominal or stock lengths with a 2 ft (610 mm) range, at least 93% of such material shall be within the range specified; the balance may be in shorter lengths but in no case shall lengths less than 4 ft (1220 mm) be furnished.

**TABLE 7**  
**PERMISSIBLE VARIATIONS IN STRAIGHTNESS OF**  
**COLD-WORKED RODS AND BARS**

Specified Diameter or Distance Between Parallel Surfaces, in. (mm) <sup>4</sup>	Permissible Variations in Lengths Indicated, in. (mm)
Rounds: 1/2 (12.7) to 4 (101.6), incl	Depth of Chord: 0.030 (0.76) per ft (305 mm) of length
Hexagons, squares, rectangles: 1/2 (12.7) to 4 (101.6), incl	0.030 (0.76) per ft (305 mm) of length

<sup>4</sup> Material under 1/2 in. (12.7 mm) shall be reasonably straight and free of sharp bends and kinks.

ends; material ordered to cut lengths will be furnished with square saw-cut or machined ends.

**7.6 Straightness:**

**7.6.1** The permissible variations in straightness of cold-worked rod and bar as determined by the departure from straightness shall be as prescribed in Table 7.

**7.6.2** The permissible variations in straightness of precision straightened cold-worked rod as determined by the departure from straightness shall be as prescribed in Table 8.

**7.6.2.1** In determining straightness in the standard 42-in. (1.07-m) distance between supports or, when specified, in determining straightness in lengths not in excess of those shown in Table 8, the rod shall be placed on a precision table equipped with ballbearing rollers and a micrometer or dial indicator. The rod shall then be rotated slowly against the indicator, and the deviation from

straightness in any portion of the rod between the supports shall not exceed the permissible variations prescribed in Table 8. The deviation from straightness (throw in one revolution) is defined as the difference between the maximum and minimum readings of the dial indicator in one complete revolution of the rod.

**7.6.3** The permissible variations in straightness of hot-worked rod and bar as determined by the departure from straightness shall be as specified in Table 9.

**8. Workmanship, Finish, and Appearance**

**8.1** The material shall be uniform in quality and condition, smooth, commercially straight or flat, and free of injurious imperfections.

**9. Sampling**

**9.1 Lot—Definition:**

**9.2** A lot for chemical analysis shall consist of one heat.

**9.2.1** A lot for mechanical properties testing shall consist of all material from the same heat, nominal diameter of thickness and condition.

**9.2.1.1** Where material cannot be identified by heat, a lot shall consist of not more than 500 lb (227 kg) of material in the same size and condition.

**9.3 Test Material Selection:**

**9.3.1 Chemical Analysis** — Representative samples from each lot shall be taken during pouring or subsequent processing.

**9.3.1.1** Product (check) analysis shall be wholly the responsibility of the purchaser.

**TABLE 8**  
**PERMISSIBLE VARIATIONS IN STRAIGHTNESS OF PRECISION-STRAIGHTENED**  
**COLD-WORKED NICKEL (UNS N02200) SHAFTING**

Specified Diameter of Shafting, in.	Standard Distance Between Supports	Permissible Variations (Throw in One Revolution) from Straightness, in.
1/2 to 15/16, incl	42 in.	0.005
Over 15/16 to 1 15/16, incl	42 in.	0.006
Over 1 15/16 to 2 1/2, incl	42 in.	0.007
Over 2 1/2 to 4, incl	42 in.	0.008
3/4 to 15/16, incl	Specified lengths of 3 to 10 ft	0.004 + 0.0025 for each foot or fraction thereof in excess of 3 ft.
Over 15/16 to 4, incl	Specified lengths of 20 ft and less	0.005 + 0.0015 for each foot or fraction thereof in excess of 3 ft.
Specified Diameter of Shafting, mm	Standard Distance Between Supports	Permissible Variations (Throw in One Revolution) from Straightness, mm
12.7 to 23.8 incl	1067 mm	0.13
Over 23.8 to 49.2, incl	1067 mm	0.15
Over 49.2 to 63.5, incl	1067 mm	0.18
Over 63.5 to 101.6, incl	1067 mm	0.20
19.1 to 23.8 incl	specified lengths of 914 to 3050 mm	10.2 + 0.2 for each metre or fraction thereof in excess of 914 mm
Over 23.8 to 101.6, incl	specified lengths of 6100 mm and less	12.7 + 0.13 for each metre or fraction thereof in excess of 914 mm

TABLE 9  
PERMISSIBLE VARIATIONS IN STRAIGHTNESS OF  
HOT-WORKED RODS AND BARS<sup>A</sup>

Finish	Permissible Variations, in./ft. (mm/m) <sup>B</sup>
Rods and bars, hot-worked	0.050 (4.2) <sup>C</sup>
Rounds—hot-worked, rough-ground, or rough-turned	0.050 (4.2) <sup>C</sup>

<sup>A</sup> Not applicable to forging quality.

<sup>B</sup> Material under ½ in. (12.7 mm) shall be reasonably straight and free of sharp bends and kinks.

<sup>C</sup> The maximum curvature (depth of chord) shall not exceed the values indicated multiplied by the length in feet.

**9.3.2 Mechanical Properties**— Samples of the material to provide test specimens for mechanical properties shall be taken from such locations in each lot as to be representative of that lot.

## 10. Number of Tests

**10.1 Chemical Analysis**—One test per lot.

**10.2 Tension**—One test per lot.

**10.3 Hardness**—One test per lot.

## 11. Specimen Preparation

**11.1** Tension test specimens shall be taken from material in the final condition and tested in the direction of fabrication.

**11.1.1** All rod and bar shall be tested in full cross-section size when possible. When a full cross-section size test cannot be performed, the largest possible round specimen shown in Test Methods E 8 shall be used. Longitudinal strip specimens shall be prepared in accordance with Test Methods E 8 for rectangular bar up to ½ in. (12.7 mm), inclusive, in thicknesses that are too wide to be pulled full size.

**11.2** Hardness test specimens shall be taken from material in the final condition.

**11.3** In order that the hardness determinations may be in reasonable close agreement, the following procedure is suggested:

**11.3.1** For rod, under ½ in. (12.7 mm) in diameter, hardness readings shall be taken on a flat surface prepared by filing or grinding approximately ⅙ in. (1.6 mm) from the outside surface of the rod.

**11.3.2** For rod, ½ in. (12.7 mm) in diameter and larger, and for hexagonal, square, and rectangular bar, all sizes, hardness readings shall be taken on a cross section midway between the surface and center of the section.

## 12. Test Methods

**12.1** The chemical composition, mechanical, and other properties of the material as enumerated in this specification shall be determined, in case of disagreement, in accordance with the following methods:

Test	ASTM Designation
Chemical Analysis	E 1473
Tension	E 8
Rockwell Hardness	E 18
Hardness Conversion	E 140
Rounding Procedure	E 29

**12.2** For purposes of determining compliance with the specified limits for requirements of the properties listed in the following table, an observed value or a calculated value shall be rounded as indicated below, in accordance with the rounding method of Practice E29:

Test	Rounded Unit for Observed or Calculated Value
Chemical composition, hardness, and tolerances (when expressed in decimals)	Nearest unit in the last right-hand place of figures of the specified limit. If two choices are possible, as when the digits dropped are exactly a 5, or a 5 followed only by zeros, choose the one ending in an even digit, with zero defined as an even digit.
Tensile strength and yield strength	Nearest 1000 psi (6.9 MPa)
Elongation	Nearest 1%

## 13. Inspection

**13.1** Inspection of the material shall be made as agreed upon between the manufacturer and the purchaser as part of the purchase contract.

## 14. Rejection and Rehearing

**14.1** Material that fails to conform to the requirements of this specification may be rejected. Rejection should be reported to the producer or supplier promptly and in writing. In case of dissatisfaction with the results of the test, the producer or supplier may make claim for a rehearing.

## 15. Certification

**15.1** A manufacturer's certification shall be furnished to the purchaser stating that material has been manufactured, tested, and inspected in accordance with this specification, and that the test results on representative samples meet specification requirements. A report of the test results shall be furnished.

**16. Product Marking**

**16.1** The following information shall be marked on the material or included on the package, or on a label or tag attached thereto: The name of the material or UNS Number, heat number, condition (temper), ASTM Specification B 160, the size, gross, tare, and net weight, consignor and

consignee address, contract or order number, or such other information as may be defined in the contract or order.

**17. Keywords**

**17.1** bar; rod; N02200; N02201; N02211

ASMENORMDOC.COM : Click to view the full PDF of ASME BPVC.II.B (ASME BPVC Section II part B) 2025

## APPENDIX

## (Nonmandatory Information)

**X1. CONDITIONS AND FINISHES**

**X1.1** The various conditions and finishes in which nickel (UNS N02200) and low-carbon nickel (UNS N02201) rods and bars are procurable are as indicated below.

**X1.2** Low-carbon nickel (UNS N02201) is intended essentially for fused caustic and other fused salts and for temperatures above 600°F (316°C). For such applications the manufacturer should be consulted.

**X1.2.1** *Hot-Worked* — With a tightly adherent, black, mill oxide surface.

**X1.2.2** *Hot-Worked Rough-Ground* — Similar to X1.2.1 except rough-ground.

**X1.2.3** *Hot-Worked, Rough-Turned* — Similar to X1.2.1 except rough-turned with a broad-nosed tool similar to a bar peeling operation and thus may not be straight. Intended generally for machining where an overhauled surface is desired, essentially for machined step down shafts or parts machined in short lengths of 3 ft (914 mm) or less.

**X1.2.4** *Hot-Worked Forging Quality* — Rough-turned and spot-ground, as necessary, for sizes 1 in.

(25.4 mm) in diameter and over; rough-ground and spot-ground for sizes under 1 in. in diameter. Material is selected from heats of known, good hot malleability.

NOTE X1.1— For sizes 4 in. (101.6 mm) in diameter and less, cold-worked rod may be used also for forging by virtue of the fact such rod have been overhauled for removal of mechanical surface defects prior to cold drawing. In such cases, the user should run pilot forging tests to ensure himself that such material has the desired hot-malleability range.

**X1.2.5** *Hot-Worked, Annealed* — Soft with a tightly adherent oxide that may vary from dark to light.

**X1.2.6** *Hot-Worked, Annealed and Pickled* — Same as X1.2.5 except descaled for removal of mill oxide. Provides for better surface inspection than does hot-worked material and often employed where welding is involved where removal of mill oxide is desired.

NOTE X1.2— Annealing prior to pickling may be required in order to reduce the mill oxide since uniform pickling of an unreduced oxide is difficult.

**X1.2.7** *Cold-Worked, As-worked* — Hot-worked overhauled, cold-worked, and straightened with a smooth bright finish.

**X1.2.8** *Cold-worked Annealed* — Hot-worked overhauled, cold-worked, and straightened. Annealed for softness and with a dull matte finish.

ASMENORMDOC.COM : Click to view the full PDF of ASME BPVC.II.B (ASME BPVC Section II part B) 2025

INTENTIONALLY LEFT BLANK

# SPECIFICATION FOR NICKEL SEAMLESS PIPE AND TUBE



**SB-161**

(Identical with ASTM Specification B161-05(2014) except for deletion of 1.1.1. Certification has been made mandatory.)

ASMENORMDOC.COM : Click to view the full PDF of ASME BPVC.II.B (ASME BPVC Section II part B) 2025

# SPECIFICATION FOR NICKEL SEAMLESS PIPE AND TUBE



SB-161

[Identical with ASTM Specification B 161-05(2014) except for deletion of 1.1.1. Certification has been made mandatory.]

## 1. Scope

**1.1** This specification covers nickel (UNS N02200) and low-carbon nickel (UNS N02201) in the form of cold-worked seamless pipe and tube in the conditions shown in Table 1 and Table X1.1.

### 1.1.1 DELETED

**1.2** The values stated in inch-pound units are to be regarded as the standard. The values given in parentheses are for information only.

**1.3** *This standard does not purport to address all of the safety concerns, if any, associated with its use. It is the responsibility of the user of this standard to become familiar with all hazards including those identified in the appropriate Material Safety Data Sheet (MSDS) for this product/material as provided by the manufacturer, to establish appropriate safety and health practices, and determine the applicability of regulatory limitations.*

## 2. Referenced Documents

### 2.1 ASTM Standards:

B 829 Specification for General Requirements for Nickel and Nickel Alloys Seamless Pipe and Tube

## 3. General Requirement

**3.1** Material furnished under this specification shall conform to the applicable requirements of Specification B 829 unless otherwise provided herein.

## 4. Ordering Information

**4.1** It is the responsibility of the purchaser to specify all requirements that are necessary for the safe and satisfactory performance of material ordered under this specification. Examples of such requirements include, but are not limited to, the following:

**4.1.1** Alloy name or UNS number.

**4.1.2** ASTM designation and year of issue.

**4.1.3** Condition (see Appendix X2).

**4.1.4** Finish (see Appendix X2).

**4.1.5** Dimensions:

**4.1.5.1** *Tube* — Specify outside diameter and nominal or minimum wall.

**4.1.5.2** *Pipe* — Specify standard pipe size and schedule.

**4.1.5.3** *Length* — Cut to length or random.

**4.1.6** *Quantity* — Feet or number of pieces.

**4.1.7** *Hydrostatic Test or Nondestructive Electric Test* — Specify test (see 6.2).

**4.1.8** *Hydrostatic Pressure Requirements* — Specify test pressure if other than required by Specification B 829.

**4.1.9** DELETED

**4.1.10** *Samples for Product (Check) Analysis* — State whether samples for product (check) analysis should be furnished (see 5.2).

**4.1.11** *Purchaser Inspection* — If purchaser wishes to witness tests or inspection of material at place of manufacture, the purchase order must so state indicating which tests or inspections are to be witnessed.

**4.1.12** *Small-Diameter and Light-Wall Tube (Converter Sizes)* — See Appendix X1.

## 5. Chemical Composition

**5.1** The material shall conform to the composition limits specified in Table 2.

ASME BPVC.II.B (ASME BPVC Section II part B) 2025

TABLE 1  
MECHANICAL PROPERTIES

Condition and Size	Tensile Strength, min, psi (MPa)		Yield Strength (0.2 % offset), min, psi (MPa)		Elongation in 2 in. or 50 mm (or 4D), min, %	
	Nickel (UNS N02200)	Low-Carbon Nickel (UNS N02201)	Nickel (UNS N02200)	Low-Carbon Nickel (UNS N02201)	Nickel (UNS N02200)	Low-Carbon Nickel (UNS N02201)
Annealed:						
5 in. (127 mm) and under outside diameter	55 000 (380)	50 000 (345)	15 000 (105)	12 000 (80)	35	35
Over 5 in. (127 mm) in outside diameter	55 000 (380)	50 000 (345)	12 000 (80)	10 000 (70)	40	40
Stress-Relieved:						
All sizes	65 000 (450)	60 000 (415)	40 000 (275)	30 000 (205)	15	15

TABLE 2  
CHEMICAL REQUIREMENTS

Element	Composition, %	
	Nickel (UNS N02200)	Low-Carbon Nickel (UNS N02201)
Ni, <sup>4</sup> min	99.0	99.0
Cu, max	0.25	0.25
Fe, max	0.40	0.40
Mn, max	0.35	0.35
C, max	0.15	...
C, max	...	0.02
Si, max	0.35	0.35
S, max	0.01	0.01

<sup>4</sup> Element shall be determined arithmetically by difference.

**5.2** If a product (check) analysis is performed by the purchaser, the material shall conform to the product (check) analysis variations in Specification B 829.

## 6. Mechanical and Other Properties

**6.1 Tension Test** — The material shall conform to the tensile properties specified in Table 1. The sampling and specimen preparation are as covered in Specification B 829.

**6.1.1** Tensile properties for material specified as small-diameter and light-wall tube (converter sizes) shall be as prescribed in Table X1.1.

**6.2 Hydrostatic Test or Nondestructive Electric Test** — Each pipe or tube shall be subjected to the Nondestructive Electric Test or the Hydrostatic Test. Unless specified by the purchaser, either test may be used at the option of the producer.

## 7. Dimensions and Permissible Variations

**7.1** Permissible variations for material specified as small-diameter and light-wall tube (converter size) shall conform to the permissible variations prescribed in Table X1.2.

## 8. Number of Tests

**8.1 Chemical Analysis** — One test per lot.

**8.2 Tension** — One test per lot.

**8.3 Hydrostatic or Nondestructive Electric Test** — Each piece in each lot.

## 9. Test Methods

**9.1 Hydrostatic Test** — Each pipe or tube with an outside diameter  $\frac{1}{8}$  in. (3 mm) and larger and with wall thickness of 0.015 in. (0.38 mm) and over shall be tested in accordance with Specification B 829. The allowable fiber stress, for material in the condition furnished, is as follows:

	UNS N02200	UNS N02201
Annealed:		
5 in. (127 mm) outside diameter and under	10 000 psi (70 MPa)	8000 psi (55 MPa)
Over 5 in. outside diameter	8000 psi (55 MPa)	6700 psi (45 MPa)
Stress-Relieved:		
All sizes	16 200 psi (110 MPa)	15 000 psi (105 MPa)

**9.1.1** When so agreed upon by the manufacturer and purchaser, pipe or tube may be tested to  $1\frac{1}{2}$  times the allowable fiber stress given above.

**9.1.2** If any pipe or tube shows leaks during hydrostatic testing, it shall be rejected.

**9.2 Nondestructive Electric Test** — Each pipe or tube shall be examined with a nondestructive electric test as prescribed in Specification B 829.

## 10. Keywords

**10.1** seamless pipe; seamless tube; N02200; N02201

## APPENDIXES

## (Nonmandatory Information)

**X1. CONVERTER SIZES**

**X1.1** Small-diameter and light-wall tube in outside diameters  $1\frac{1}{4}$  in. (31.8 mm) and under may be furnished in the conditions listed in Table X1.1 when so specified. The material is furnished in a limited range of sizes and the manufacturer should be consulted as to the various outside diameters and wall thicknesses that may be furnished. Material will have a bright finish. Such material shall conform to the applicable requirements in Table X1.1 and Table X1.2.

**X2. CONDITIONS AND FINISHES NORMALLY SUPPLIED****X2.1 Scope**

**X2.1.1** This appendix lists the conditions and finishes in which pipe and tube (other than converter sizes) are

normally supplied. These are subject to change, and the manufacturer should be consulted for the latest information available.

**X2.2 Nickel (UNS N02200)**

**X2.2.1 Annealed** — Soft, with a dull matte finish.

**X2.2.2 Stress-Relieved** — Thermally treated below the annealing temperature to relieve the major portion of the internal stresses, with a thin, light to medium-dark surface.

**X2.3 Low-Carbon Nickel (UNS N02201)**

**X2.3.1 Annealed** — Similar to X2.2.1.

**X2.3.2 Stress-Relieved** — Similar to X2.2.2.

TABLE X1.1  
MECHANICAL PROPERTIES<sup>4</sup> OF SMALL-DIAMETER AND LIGHT-WALL TUBING (CONVERTER SIZES)

Condition	Tensile Strength, psi (MPa)	Yield Strength (0.2 % offset), min, psi (MPa)	Elongation in 2 in. or 50 mm, min, %
Nickel UNS N02200			
Annealed <sup>B</sup>	75 000 (515) max	15 000 (105)	33
Half-hard <sup>C</sup>	80 000 (550) min	40 000 (275)	12
Full hard <sup>D</sup>	95 000 (655) min	75 000 (515)	4
Low-Carbon Nickel UNS N02201			
Annealed <sup>B</sup>	70 000 (480) max	12 000 (85)	35
Half-hard <sup>C</sup>	70 000 (480) min	30 000 (205)	12
Full hard <sup>D</sup>	85 000 (585) min	65 000 (450)	4

<sup>4</sup> Not applicable to outside diameters under  $\frac{1}{8}$  in. (3.2 mm) and wall thicknesses under 0.015 in. (0.38 mm).

<sup>B</sup> This condition is sometimes designated as "No. 1 Temper."

<sup>C</sup> This condition is sometimes designated as "No. 2 Temper."

<sup>D</sup> This condition is sometimes designated as "No. 3 Temper."

TABLE X1.2  
 PERMISSIBLE VARIATIONS FOR SMALL-DIAMETER AND LIGHT-WALL TUBE (CONVERTER SIZES)<sup>A,B,C,D,E,F</sup>

Specified Outside Diameter, in. (mm)	Outside Diameter		Inside Diameter		Wall Thickness, %	
	Plus	Minus	Plus	Minus	Plus	Minus
Under $\frac{3}{32}$ (2.4)	0.002 (0.05)	0	0	0.002 (0.05)	10	10
$\frac{3}{32}$ to $\frac{3}{16}$ (2.4 to 4.8), excl	0.003 (0.08)	0	0	0.003 (0.08)	10	10
$\frac{3}{16}$ to $\frac{1}{2}$ (4.8 to 12.7), excl	0.004 (0.10)	0	0	0.004 (0.10)	10	10
$\frac{1}{2}$ to $1\frac{1}{4}$ (12.7 to 31.8), incl	0.005 (0.13)	0	0	0.005 (0.13)	10	10

<sup>A</sup> *Ovality, Normal Wall Tubes — As Drawn (No. 2 and 3) Tempers* — Ovality will be held within the outside diameter tolerances shown in the table.

*Annealed (No. 1) Temper* — Ovality will be held within 2% of the theoretical average outside diameter.

<sup>B</sup> *Ovality, Light-Wall Tube — As-Drawn (No. 2 and 3) Tempers* — Up to but not including  $1\frac{1}{4}$  in. (31.8 mm) in outside diameter, ovality will be held within 2% of the theoretical average outside diameter.

*Annealed (No. 1) Temper* — Ovality will be held within 3% of the theoretical average outside diameter.

<sup>C</sup> *Wall Tolerances, Light-Wall Tube* — The plus and minus wall tolerance shown in the table shall apply down to and including 0.005 in. (0.13 mm) in wall thickness. For wall thicknesses less than 0.005 in. (0.13 mm), the tolerance shall be  $\pm 0.0005$  in. (0.013 mm).

<sup>D</sup> *Random Lengths:*

Where nominal random lengths on tubing  $\frac{1}{8}$  in. (3.2 mm) and larger in outside diameter are specified, a length tolerance of  $\pm 3\frac{1}{2}$  ft (1.06 m) applies to the nominal length. This is a total spread of 7 ft (2.10 m).

Random lengths in sizes  $\frac{1}{8}$  in. (3.2 mm) and larger in outside diameter shall be subject to a length range of 5 to 24 ft (1.50 to 7.30 m). Long random lengths are subject to a range of 15 to 22 ft (4.57 to 6.70 m).

Random lengths in sizes up to, but not including  $\frac{1}{8}$  in. (3.2 mm) in outside diameter, and fragile light-wall tubes over this outside diameter are subject to the length range of 1 to 15 ft (0.30 to 4.57 m).

<sup>E</sup> *Straightness* — Round tubing is subject to a straightness tolerance of one part in 600 [equivalent to a depth of arc of 0.030 in. (0.76 mm) in any 3 ft (0.91 m) of length].

<sup>F</sup> When specified, the tolerance spreads of this table may be applied as desired. However, when not specified, the tolerances in this table will apply. It should be noted that inside diameter tolerances are based upon the outside diameter range.

ASME BPVC Section II Part B) 2025  
 ASME BPVC.II.B (ASME BPVC Section II Part B) 2025  
 ASMENORMDOC.COM : Click to view the full PDF of ASME BPVC.II.B (ASME BPVC Section II Part B) 2025

# SPECIFICATION FOR NICKEL PLATE, SHEET, AND STRIP



**SB-162**

(Identical with ASTM Specification B162-99(2014) except that certification has been made mandatory.)

ASMENORMDOC.COM : Click to view the full PDF of ASME BPVC.II.B (ASME BPVC Section II part B) 2025

# SPECIFICATION FOR NICKEL PLATE, SHEET, AND STRIP



SB-162

[Identical with ASTM Specification B 162-99(2014) except that certification has been made mandatory.]

## 1. Scope

**1.1** This specification covers rolled nickel (UNS N02200) and low-carbon nickel (UNS N02201) plate, sheet, and strip.

**1.2** The values stated in inch–pound units are to be regarded as the standard. The other values given are for information only.

## 2. Referenced Documents

### 2.1 ASTM Standards:

- B 160 Specification for Nickel Rod and Bar
- B 880 General Requirements for Chemical Check Analysis of Nickel, Nickel Alloys, and Cobalt Alloys
- E 8 Test Methods for Tension Testing of Metallic Materials
- E 10 Test Method for Brinell Hardness of Metallic Materials
- E 18 Test Methods for Rockwell Hardness and Rockwell Superficial Hardness of Metallic Materials
- E 29 Practice for Using Significant Digits in Test Data to Determine Conformance with Specifications
- E 39 Test Methods for Chemical Analysis of Nickel
- E 112 Test Methods for Determining the Average Grain Size
- E 140 Hardness Conversion Tables for Metals
- F 155 Test Method for Temper of Strip and Sheet Metals for Electronic Devices (Spring-Back Method)

## 3. Terminology

### 3.1 Descriptions of Terms Specific to This Standard:

**3.1.1** The terms given in Table 1 shall apply.

## 4. Ordering Information

**4.1** It is the responsibility of the purchaser to specify all requirements that are necessary for the safe and satisfactory performance of material ordered under this specification. Examples of such requirements include, but are not limited to, the following:

**4.1.1** *Alloy* — Name and UNS number. (See Table 2.)

**4.1.2** *ASTM designation*, including year of issue.

**4.1.3** *Condition* (See 6.1, 6.2, and Appendix X1.)

**4.1.4** *Finish* (See Appendix X1.)

**4.1.5** *Dimensions* — Thickness, width, and length.

**4.1.6** *Quantity*.

**4.1.7** *Optional Requirements*:

**4.1.7.1** *Sheet and Strip* — Whether to be furnished in coil, in cut straight lengths, or in random straight lengths.

**4.1.7.2** *Strip* — Whether to be furnished with commercial slit edge, square edge, or round edge.

**4.1.7.3** *Plate* — Whether to be furnished specially flattened (see 7.7.2); also how plate is to be cut (see 7.2.1 and 7.3.2.)

**4.1.8** *Fabrication Details* — Not mandatory but helpful to the manufacturer.

**4.1.8.1** *Welding or Brazing* — Process to be employed.

**4.1.8.2** *Plate* — Whether material is to be hot-formed.

**4.1.9** *Certification* — Certification and a report of test results are required (see Section 15).

**4.1.10** *Samples for Product (Check) Analysis* — Whether samples for product (check) analysis should be furnished (see 5.2).

TABLE 1  
PRODUCT DESCRIPTION

Product	Thickness, in. (mm)	Width, in. (mm)
Hot-rolled plate <sup>A</sup>	$\frac{3}{16}$ and over (Tables 5 and 6)	(Table 8) <sup>B</sup>
Hot-rolled sheet <sup>A</sup>	0.018 to 0.250 (0.46 to 6.4), incl (Table 7)	(Table 10)
Cold-rolled sheet <sup>C</sup>	0.018 to 0.250 (0.46 to 6.4), incl (Table 7)	(Table 10)
Cold-rolled strip <sup>C</sup>	0.005 to 0.250 (0.13 to 6.4), incl (Table 7)	(Table 10)

<sup>A</sup> Material  $\frac{3}{16}$  to  $\frac{1}{4}$  in. (4.8 to 6.4 mm), incl, in thickness may be furnished as sheet or plate provided the material meets the specification requirements for the condition ordered.

<sup>B</sup> Hot-rolled plate, in widths 10 in. (254 mm) and under, may be furnished as hot-finished rectangles with sheared or cut edges in accordance with Specification B 160, provided the mechanical property requirements of this specification are met.

<sup>C</sup> Material under 48 in. (1219 mm) in width may be furnished as sheet or strip provided the material meets the specification requirements for the condition ordered.

TABLE 2  
CHEMICAL REQUIREMENTS

Element	Composition, %	
	Nickel (UNS N02200)	Low-Carbon Nickel (UNS N02201)
Nickel, <sup>A</sup> min	99.0	99.0
Copper, max	0.25	0.25
Iron, max	0.40	0.40
Manganese, max	0.35	0.35
Carbon, max	0.15	...
Carbon, max	...	0.02
Silicon, max	0.35	0.35
Sulfur, max	0.01	0.01

<sup>A</sup> Element shall be determined arithmetically by difference.

**4.1.11 Purchaser Inspection** — If the purchaser wishes to witness tests or inspection of material at the place of manufacture, the purchase order must so state indicating which tests or inspections are to be witnessed (see Section 13).

## 5. Chemical Compositions

**5.1** The material shall conform to the requirements as to chemical composition prescribed in Table 2.

**5.2** If a product (check) analysis is performed by the purchaser, the material shall be done per ASTM B 880 and the material shall conform to the product (check) analysis variations defined in Table 1 of ASTM B 880.

## 6. Mechanical and Other Requirements

**6.1 Mechanical Properties** — The material shall conform to the requirements for mechanical properties prescribed in Table 3.

**6.2 Deep-Drawing and Spinning Quality Sheet and Strip** — The material shall conform to the requirements for grain size and hardness properties prescribed in Table 4.

**6.2.1** The mechanical properties of Table 3 do not apply to deep-drawing and spinning quality sheet and strip.

## 7. Dimensions and Permissible Variations

### 7.1 Thickness and Weight:

**7.1.1 Plate** — For plate up to 2 in. (50.8 mm), inclusive, in thickness, the permissible variation under the specified thickness and permissible excess in overweight shall not exceed the amounts prescribed in Table 5.

**7.1.1.1** For use with Table 5, plate shall be assumed to weigh 0.321 lb/in.<sup>3</sup> (8.89 g/cm<sup>3</sup>).

**7.1.2 Plate** — For plate over 2 in. (50.8 mm) in thickness, the permissible variations over the specified thickness shall not exceed the amounts prescribed in Table 6.

**7.1.3 Sheet and Strip** — The permissible variations in thickness of sheet and strip shall be as prescribed in Table 7. The thickness of strip and sheet shall be measured with the micrometer spindle  $\frac{3}{8}$  in. (9.5 mm) or more from either edge for material 1 in. (25.4 mm) or over in width and at any place on the strip under 1 in. in width.

### 7.2 Width and Diameter:

**7.2.1 Plate** — The permissible variations in width of rectangular plates and diameter of circular plates shall be as prescribed in Tables 8 and 9.

**7.2.2 Sheet and Strip** — The permissible variations in width for sheet and strip shall be as prescribed in Table 10.

### 7.3 Length:

**7.3.1** Sheet and strip of all sizes may be ordered to cut lengths, in which case a variation of  $\frac{1}{8}$  in. (3.2 mm) over the specified length shall be permitted.

TABLE 3  
MECHANICAL PROPERTIES FOR PLATE, SHEET, AND STRIP (ALL THICKNESSES AND SIZES UNLESS OTHERWISE INDICATED)

Condition (Temper)	Tensile Strength, min, psi (MPa)	Yield <sup>A</sup> Strength (0.2 % offset), min, psi (MPa)	Elongation in 2 in. or 50 mm, or 4D, min, %	Rockwell Hardness (B Scale) <sup>B,C</sup>
Nickel (UNS N02200) Hot-Rolled Plate				
Annealed	55 000 (380)	15 000 (100)	40	...
As-rolled <sup>D,E</sup>	55 000 (380)	20 000 (135)	30	...
Nickel (UNS N02200) Hot-Rolled Sheet				
Annealed	55 000 (380)	15 000 (100)	40 <sup>F</sup>	...
Nickel (UNS N02200) Cold-Rolled Sheet				
Annealed	55 000 (380)	15 000 (100)	40 <sup>F</sup>	...
Quarter-hard	...	...	...	70 to 80
Half-hard	...	...	...	79 to 86
Hard	90 000 (620)	70 000 (480)	2	...
Nickel (UNS N02200) Cold-Rolled Strip				
Annealed	55 000 (380) <sup>G</sup>	15 000 (100)	40 <sup>F,G</sup>	...
Skin-hard	...	...	...	64 to 70
Quarter-hard	...	...	...	70 to 80
Half-hard	...	...	...	79 to 86
Three-quarter-hard	...	...	...	85 to 91
Hard	90 000 (620) <sup>G</sup>	70 000 (480)	2 <sup>G</sup>	...
Spring temper	...	...	...	95 min
Low-Carbon Nickel (UNS N02201) Hot-Rolled Plate				
Annealed	50 000 (345)	12 000 (80)	40	...
As-rolled <sup>D,E</sup>	50 000 (345)	12 000 (80)	30	...
Low-Carbon Nickel (UNS N02201) Hot-Rolled Sheet				
Annealed	50 000 (345)	12 000 (80)	40 <sup>F</sup>	...
Low-Carbon Nickel (UNS N02201) Cold-Rolled Sheet				
Annealed	50 000 (345)	12 000 (80)	40 <sup>F</sup>	...
Low-Carbon Nickel (UNS N02201) Cold-Rolled Strip				
Annealed	50 000 (345) <sup>G</sup>	12 000 (80)	40 <sup>F,G</sup>	...

<sup>A</sup> Yield strength requirements do not apply to material under 0.020 in. (0.51 mm) in thickness.

<sup>B</sup> For Rockwell or equivalent hardness conversions see Hardness Conversion Tables E 140.

<sup>C</sup> Caution should be observed in using the Rockwell test on thin material, as the results may be affected by specimen thickness. For thicknesses under 0.050 in. (1.3 mm), the use of the Rockwell superficial or the Vickers hardness test is suggested.

<sup>D</sup> As-rolled plate may be given a stress-relieving heat treatment subsequent to final rolling.

<sup>E</sup> As-rolled plate specified "suitable for hot forming" shall be furnished from heats of known good hot-malleability characteristics (see X1.2.2). There are no applicable tensile or hardness requirements for such material.

<sup>F</sup> Sheet and strip 0.010 to 0.049 in. (0.25 to 1.2 mm), inclusive, in thickness shall have an elongation of 30% minimum. Sheet and strip 0.050 to 0.109 in. (1.3 to 2.7 mm), inclusive, in thickness shall have an elongation of 35% minimum.

<sup>G</sup> Not applicable for thickness under 0.010 in. (0.25 mm).

TABLE 4  
GRAIN SIZE AND HARDNESS FOR COLD-ROLLED, DEEP-DRAWING, AND SPINNING QUALITY SHEET AND STRIP

Thickness, in. (mm)	Calculated Diameter of Average Grain Section, max		Corresponding ASTM Micro-Grain Size No.	Rockwell B <sup>A,B</sup> Hardness, max
	mm	in.		
Nickel (UNS N02200) Sheet [56 in. (1420 mm) Wide and Under] <sup>C</sup>				
0.050 (1.3) and less	0.110	0.0043	3.5	64
Over 0.050 to 0.250 (1.3 to 6.4), incl	0.120	0.0047	3.0	64
Nickel (UNS N02200) Strip [12 in. (305 mm) Wide and Under] <sup>D</sup>				
0.005 <sup>E</sup> to 0.010 (0.13 to 0.25), incl	0.025	0.0010	7.5 <sup>F</sup>	70 <sup>F</sup>
Over 0.010 to 0.024 (0.25 to 0.61), incl	0.065	0.0026	5.0	68
Over 0.024 to 0.125 (0.61 to 3.2), incl	0.110	0.0043	3.5	64
Low-Carbon Nickel (UNS N02201) Strip [12 in. (305 mm) Wide and Under] <sup>D</sup>				
0.005 <sup>E</sup> to 0.010 (0.13 to 0.25), incl	0.030	0.0012	7.0 <sup>F</sup>	66 <sup>F</sup>
Over 0.010 to 0.024 (0.25 to 0.61), incl	0.075	0.0030	4.5	64
Over 0.024 to 0.125 (0.61 to 3.2), incl	0.110	0.0043	3.5	64

<sup>A</sup> For Rockwell or equivalent hardness conversions see Hardness Conversion Tables E 140.

<sup>B</sup> Caution should be observed in using the Rockwell test on thin material, as the results may be affected by specimen thickness. For thicknesses under 0.050 in. (1.3 mm), the use of the Rockwell superficial or the Vickers hardness test is suggested.

<sup>C</sup> There are no applicable grain size requirements for low-carbon nickel (UNS N02201) sheet. The hardness of low-carbon nickel (UNS N02201) sheet shall be not over Rockwell B64, or equivalent.

<sup>D</sup> Sheet requirements in Table 4 apply to strip thicknesses over 0.125 in. (3.2 mm), and for all thicknesses of strip over 12 in. (305 mm) in width.

<sup>E</sup> For ductility evaluations for strip under 0.005 in. (0.13 mm) in thickness, the spring-back test, such as that described in Test Method F 155, is often used and the manufacturer should be consulted.

<sup>F</sup> Accurate grain size and hardness determinations are difficult to make on strip under 0.005 in. (0.13 mm) in thickness and are not recommended.

TABLE 5  
PERMISSIBLE VARIATIONS IN THICKNESS AND OVERWEIGHT OF RECTANGULAR PLATES

Specified Thickness, in. (mm)	Permissible Excess in Average Weight, <sup>B,C</sup> per Square Foot of Plates for Widths Given in Inches (millimetres) Expressed in Percentage of Nominal Weights									
	Under 48 (1220)	48 to 60 (1220 to 1520), excl	60 to 72 (1520 to 1830), excl	72 to 84 (1830 to 2130), excl	84 to 96 (2130 to 2440), excl	96 to 108 (2440 to 2740), excl	108 to 120 (2740 to 3050), excl	120 to 132 (3050 to 3350), excl	132 to 144 (3350 to 3660), excl	144 to 160 (3660 to 4070), incl
$\frac{3}{16}$ to $\frac{5}{16}$ (4.8 to 7.9), excl	9.0	10.5	12.0	13.5	15.0	16.5	18.0	...	...	...
$\frac{5}{16}$ to $\frac{3}{8}$ (7.9 to 9.5), excl	7.5	9.0	10.5	12.0	13.5	15.0	16.5	18.0	...	...
$\frac{3}{8}$ to $\frac{7}{16}$ (9.5 to 11.1), excl	7.0	7.5	9.0	10.5	12.0	13.5	15.0	16.5	18.0	19.5
$\frac{7}{16}$ to $\frac{1}{2}$ (11.1 to 12.7), excl	6.0	7.0	7.5	9.0	10.5	12.0	13.5	15.0	16.5	18.0
$\frac{1}{2}$ to $\frac{5}{8}$ (12.7 to 15.9), excl	5.0	6.0	7.0	7.5	9.0	10.5	12.0	13.5	15.0	16.5
$\frac{5}{8}$ to $\frac{3}{4}$ (15.9 to 19.0), excl	4.5	5.5	6.0	7.0	7.5	9.0	10.5	12.0	13.5	15.0
$\frac{3}{4}$ to 1 (19.0 to 25.4), excl	4.0	4.5	5.5	6.0	7.0	7.5	9.0	10.5	12.0	13.5
1 to 2 (25.4 to 50.8), incl	4.0	4.0	4.5	5.5	6.0	7.0	7.5	9.0	10.5	12.0

NOTE — All plates shall be ordered to thickness and not to weight per square foot. No plates shall vary more than 0.01 in. (0.25 mm) under the thickness ordered, and the overweight of each lot<sup>A</sup> in each shipment shall not exceed the amount given in the table. Spot grinding is permitted to remove surface imperfections, such spots not to exceed 0.01 in. (0.25 mm) under the specified thickness.

<sup>A</sup> The term "lot" applied to this table means all of the plates of each group width and each group thickness.

<sup>B</sup> The permissible overweight for lots of circular and sketch plates shall be 25% greater than the amounts given in this table.

<sup>C</sup> The weight of individual plates shall not exceed the nominal weight by more than 1 $\frac{1}{4}$  times the amount given in the table and Footnote B.

ASME NORMDOC.COM : Click to view the full PDF of ASME BPVC.II.B-2025

TABLE 6  
PERMISSIBLE VARIATIONS IN THICKNESS FOR RECTANGULAR PLATES OVER 2 in. (50.8 mm) IN THICKNESS

Specified Thickness, in. (mm)	Permissible Variations, in. (mm), over Specified Thickness for Widths Given, in. (mm)					
	To 36 (915), excl	36 to 60 (915 to 1520), excl	60 to 84 (1520 to 2130), excl	84 to 120 (2130 to 3050), excl	120 to 132 (3050 to 3350), excl	132 (3350) and over
Over 2 to 3 (51.0 to 76.0), excl	$\frac{1}{16}$ (1.6)	$\frac{3}{32}$ (2.4)	$\frac{7}{64}$ (2.8)	$\frac{1}{8}$ (3.2)	$\frac{1}{8}$ (3.2)	$\frac{9}{64}$ (3.6)
3 to 4 (76.0 to 102.0), incl	$\frac{5}{64}$ (2.0)	$\frac{3}{32}$ (2.4)	$\frac{7}{64}$ (2.8)	$\frac{1}{8}$ (3.2)	$\frac{1}{8}$ (3.2)	$\frac{9}{64}$ (3.6)

NOTE — Permissible variation under specified thickness, 0.01 in. (0.25 mm).

TABLE 7  
PERMISSIBLE VARIATIONS IN THICKNESS OF SHEET AND STRIP [PERMISSIBLE VARIATIONS, PLUS AND MINUS, IN THICKNESS, in. (mm), FOR WIDTHS GIVEN IN in. (mm)]

Specified Thickness, in. (mm)	Sheet <sup>A</sup>			
	Hot-Rolled		Cold-Rolled	
	48 (1220) and Under	Over 48 to 60 (1220 to 1520), incl	48 (1220) and Under	Over 48 to 60 (1220 to 1520), incl
0.018 to 0.025 (0.46 to 0.64), incl	0.003 (0.08)	0.004 (0.10)	0.002 (0.05)	0.003 (0.08)
Over 0.025 to 0.034 (0.64 to 0.86), incl	0.004 (0.10)	0.005 (0.13)	0.003 (0.08)	0.004 (0.10)
Over 0.034 to 0.043 (0.86 to 1.1), incl	0.005 (0.13)	0.006 (0.15)	0.004 (0.10)	0.005 (0.13)
Over 0.043 to 0.056 (1.1 to 1.4), incl	0.005 (0.13)	0.006 (0.15)	0.004 (0.10)	0.005 (0.13)
Over 0.056 to 0.070 (1.4 to 1.8), incl	0.006 (0.15)	0.007 (0.18)	0.005 (0.13)	0.006 (0.15)
Over 0.070 to 0.078 (1.8 to 2.0), incl	0.007 (0.18)	0.008 (0.20)	0.006 (0.15)	0.007 (0.18)
Over 0.078 to 0.093 (2.0 to 2.4), incl	0.008 (0.20)	0.009 (0.23)	0.007 (0.18)	0.008 (0.20)
Over 0.093 to 0.109 (2.4 to 2.8), incl	0.009 (0.23)	0.010 (0.25)	0.007 (0.18)	0.009 (0.23)
Over 0.109 to 0.125 (2.8 to 3.2), incl	0.010 (0.25)	0.012 (0.30)	0.008 (0.20)	0.010 (0.25)
Over 0.125 to 0.140 (3.2 to 3.6), incl	0.012 (0.30)	0.014 (0.36)	0.008 (0.20)	0.010 (0.25)
Over 0.140 to 0.171 (3.6 to 4.3), incl	0.014 (0.36)	0.016 (0.41)	0.009 (0.23)	0.012 (0.30)
Over 0.171 to 0.187 (4.3 to 4.8), incl	0.015 (0.38)	0.017 (0.43)	0.010 (0.25)	0.013 (0.33)
Over 0.187 to 0.218 (4.8 to 5.5), incl	0.017 (0.43)	0.019 (0.48)	0.011 (0.28)	0.015 (0.38)
Over 0.218 to 0.234 (5.5 to 5.9), incl	0.018 (0.46)	0.020 (0.51)	0.012 (0.30)	0.016 (0.41)
Over 0.234 to 0.250 (5.9 to 6.4), incl	0.020 (0.51)	0.022 (0.56)	0.013 (0.33)	0.018 (0.46)

Cold-Rolled Strip <sup>A,B</sup>	
Specified Thickness, in. (mm)	Widths 12 in. (305 mm) and under, ±
Up to 0.050 (1.3), incl	0.0015 (0.04)
Over 0.050 to 0.093 (1.3 to 2.4), incl	0.0025 (0.06)
Over 0.093 to 0.125 (2.4 to 3.2), incl	0.004 (0.11)

<sup>A</sup> Measured  $\frac{3}{8}$  in. (9.5 mm) or more from either edge except for strip under 1 in. (25.4 mm) in width which is measured at any place.

<sup>B</sup> Standard sheet tolerances apply for thicknesses over 0.125 in. (3.2 mm) and for all thicknesses of strip over 12 in. (305 mm) wide.

TABLE 8  
 PERMISSIBLE VARIATIONS IN WIDTH<sup>A</sup> OF SHEARED, PLASMA-TORCH CUT, AND ABRASIVE-CUT RECTANGULAR PLATE<sup>B,C</sup>

Specified Thickness	Permissible Variations in Widths for Widths Given in in. (mm)									
	Up to 30 (760), incl		Over 30 to 72 (760 to 1830), incl		Over 72 to 108 (1830 to 2740), incl		Over 108 to 144 (2740 to 3660), incl		Over 144 to 160 (3660 to 4070), incl	
	+	-	+	-	+	-	+	-	+	-
Inches										
Sheared: <sup>D</sup>										
$\frac{3}{16}$ to $\frac{5}{16}$ , excl	$\frac{3}{16}$	$\frac{1}{8}$	$\frac{1}{4}$	$\frac{1}{8}$	$\frac{3}{8}$	$\frac{1}{8}$	$\frac{1}{2}$	$\frac{1}{8}$	...	...
$\frac{5}{16}$ to $\frac{1}{2}$ , excl	$\frac{1}{4}$	$\frac{1}{8}$	$\frac{3}{8}$	$\frac{1}{8}$	$\frac{3}{8}$	$\frac{1}{8}$	$\frac{1}{2}$	$\frac{1}{8}$	$\frac{5}{8}$	$\frac{1}{8}$
$\frac{1}{2}$ to $\frac{3}{4}$ , excl	$\frac{3}{8}$	$\frac{1}{8}$	$\frac{3}{8}$	$\frac{1}{8}$	$\frac{1}{2}$	$\frac{1}{8}$	$\frac{5}{8}$	$\frac{1}{8}$	$\frac{3}{4}$	$\frac{1}{8}$
$\frac{3}{4}$ to 1, excl	$\frac{1}{2}$	$\frac{1}{8}$	$\frac{1}{2}$	$\frac{1}{8}$	$\frac{5}{8}$	$\frac{1}{8}$	$\frac{3}{4}$	$\frac{1}{8}$	$\frac{7}{8}$	$\frac{1}{8}$
1 to $1\frac{1}{4}$ , incl	$\frac{5}{8}$	$\frac{1}{8}$	$\frac{5}{8}$	$\frac{1}{8}$	$\frac{3}{4}$	$\frac{1}{8}$	$\frac{7}{8}$	$\frac{1}{8}$	1	$\frac{1}{8}$
Abrasive-cut: <sup>E,F</sup>										
$\frac{3}{16}$ to $1\frac{1}{4}$ , incl	$\frac{1}{8}$	$\frac{1}{8}$	$\frac{1}{8}$	$\frac{1}{8}$	$\frac{1}{8}$	$\frac{1}{8}$	$\frac{1}{8}$	$\frac{1}{8}$	$\frac{1}{8}$	$\frac{1}{8}$
Over $1\frac{1}{4}$ to $2\frac{3}{4}$ , incl	$\frac{3}{16}$	$\frac{1}{8}$	$\frac{3}{16}$	$\frac{1}{8}$	$\frac{3}{16}$	$\frac{1}{8}$	$\frac{3}{16}$	$\frac{1}{8}$	$\frac{3}{16}$	$\frac{1}{8}$
Plasma-torch-cut: <sup>G</sup>										
$\frac{3}{16}$ to 2, excl	$\frac{1}{2}$	0	$\frac{1}{2}$	0	$\frac{1}{2}$	0	$\frac{1}{2}$	0	$\frac{1}{2}$	0
2 to 3, incl	$\frac{5}{8}$	0	$\frac{5}{8}$	0	$\frac{5}{8}$	0	$\frac{5}{8}$	0	$\frac{5}{8}$	0
Millimetres										
Sheared: <sup>D</sup>										
4.8 to 7.9, excl	4.8	3.2	6.4	3.2	9.5	3.2	12.7	3.2	...	...
7.9 to 12.7, excl	6.4	3.2	9.5	3.2	9.5	3.2	12.7	3.2	15.9	3.2
12.7 to 19.0, excl	9.5	3.2	9.5	3.2	12.7	3.2	15.9	3.2	19.0	3.2
19.0 to 25.4, excl	12.7	3.2	12.7	3.2	15.9	3.2	19.0	3.2	22.2	3.2
25.4 to 31.8, incl	15.9	3.2	15.9	3.2	19.0	3.2	22.2	3.2	25.4	3.2
Abrasive-cut: <sup>E,F</sup>										
4.8 to 31.8, incl	3.2	3.2	3.2	3.2	3.2	3.2	3.2	3.2	3.2	3.2
Over 31.8 to 69.8, incl	4.8	3.2	4.8	3.2	4.8	3.2	4.8	3.2	4.8	3.2
Plasma-torch-cut: <sup>G</sup>										
4.8 to 50.8, excl	12.7	0	12.7	0	12.7	0	12.7	0	12.7	0
50.8 to 76.2, incl	15.9	0	15.9	0	15.9	0	15.9	0	15.9	0

<sup>A</sup> Permissible variations in width for powder-cut or inert-arc-cut plate shall be as agreed upon between the manufacturer and the purchaser.  
<sup>B</sup> Permissible variations in machined, powder-cut, or inert-arc-cut circular plate shall be as agreed upon between the manufacturer and the purchaser.  
<sup>C</sup> Permissible variations in plasma-torch-cut sketch plates shall be as agreed upon between the manufacturer and the purchaser.  
<sup>D</sup> The minimum sheared width is 10 in. (254 mm) for material  $\frac{3}{4}$  in. (19.0 mm) and under in thickness and 20 in. (508 mm) for material over  $\frac{3}{4}$  in. (19.0 mm) in thickness.  
<sup>E</sup> The minimum abrasive-cut width is 2 in. (50.8 mm) and increases to 4 in. (101.6 mm) for thicker plates.  
<sup>F</sup> These tolerances are applicable to lengths of 240 in. (6100 mm), max. For lengths over 240 in. (6100 mm), an additional  $\frac{1}{16}$  in. (1.6 mm) is permitted, both plus and minus.  
<sup>G</sup> The tolerance spread shown for plasma-torch-cutting may be obtained all on the minus side, or divided between the plus and minus side if so specified by the purchaser.

TABLE 9  
PERMISSIBLE VARIATIONS IN DIAMETER FOR CIRCULAR PLATES

Sheared Plate		Permissible Variations Over Specified Diameter for Thickness Given in in. (mm) <sup>A</sup>	
Specified Diameter, in. (mm)		To $\frac{3}{8}$ (9.5), incl	
20 to 32 (508 to 813), excl		$\frac{1}{4}$ (6.4)	
32 to 84 (813 to 2130), excl		$\frac{5}{16}$ (7.9)	
84 to 108 (2130 to 2740), excl		$\frac{3}{8}$ (9.5)	
108 to 140 (2740 to 3580), incl		$\frac{7}{16}$ (11.1)	

Plasma-Torch-Cut Plate <sup>B</sup>				
Specified Diameter, in. (mm)	Thickness max, in. (mm)	Permissible Variations in Specified Diameter for Thickness Given in in. (mm) <sup>C</sup>		
		$\frac{3}{16}$ to 2 (4.76 to 50.8), excl		2 to 3 (50.8 to 76.2), incl
		+	-	-
19 to 20 (483 to 508), excl	3 (76.2)	$\frac{1}{2}$ (12.7)	0	$\frac{5}{8}$ (15.9)
20 to 22 (508 to 559), excl	2 $\frac{3}{4}$ (69.8)	$\frac{1}{2}$ (12.7)	0	$\frac{5}{8}$ (15.9)
22 to 24 (559 to 610), excl	2 $\frac{1}{2}$ (63.5)	$\frac{1}{2}$ (12.7)	0	$\frac{5}{8}$ (15.9)
24 to 28 (610 to 711), excl	2 $\frac{1}{4}$ (57.3)	$\frac{1}{2}$ (12.7)	0	$\frac{5}{8}$ (15.9)
28 to 32 (711 to 812), excl	2 (50.8)	$\frac{1}{2}$ (12.7)	0	$\frac{5}{8}$ (15.9)
32 to 34 (812 to 864), excl	1 $\frac{3}{4}$ (44.5)	$\frac{1}{2}$ (12.7)	0	...
34 to 38 (864 to 965), excl	1 $\frac{1}{2}$ (38.1)	$\frac{1}{2}$ (12.7)	0	...
38 to 40 (965 to 1020), excl	1 $\frac{1}{4}$ (31.8)	$\frac{1}{2}$ (12.7)	0	...
40 to 140 (1020 to 3560), incl	3 (76.2)	$\frac{1}{2}$ (12.7)	0	$\frac{5}{8}$ (15.9)

<sup>A</sup> No permissible variations under.

<sup>B</sup> Permissible variations in plasma-torch-cut sketch plates shall be as agreed upon between the manufacturer and the purchaser.

<sup>C</sup> The tolerance spread shown may also be obtained all on the minus side or divided between the plus and minus sides if so specified by the purchaser.

**7.3.2** Permissible variations in length of rectangular plate shall be as prescribed in Table 11.

#### 7.4 Straightness:

**7.4.1** The edgewise curvature (depth of chord) of flat sheet, strip, and plate shall not exceed 0.05 in. multiplied by the length in feet (0.04 mm multiplied by the length in centimetres).

**7.4.2** Straightness for coiled material is subject to agreement between the manufacturer and the purchaser.

#### 7.5 Edges:

**7.5.1** When finished edges of strip are specified in the contract or order, the following descriptions shall apply:

**7.5.1.1** Square-edge strip shall be supplied with finished edges, with sharp, square corners, and without bevel or rounding.

**7.5.1.2** Round-edge strip shall be supplied with finished edges, semicircular in form, and the diameter of the circle forming the edge being equal to the strip thickness.

**7.5.1.3** When no description of any required form of strip edge is given, it shall be understood that edges such as those resulting from slitting or shearing will be acceptable.

**7.5.1.4** Sheet shall have sheared or slit edges.

**7.5.1.5** Plate shall have sheared or cut (machined, abrasive-cut, powder-cut, or inert-arc-cut) edges, as specified.

**7.6 Squareness (Sheet)** — For sheets of all thicknesses, the angle between adjacent sides shall be  $90^\circ \pm 0.15^\circ$  ( $\frac{1}{16}$  in. in 24 in.) (1.6 mm in 610 mm).

#### 7.7 Flatness:

**7.7.1** There shall be no flatness requirements for “deep drawing quality,” “spinning quality,” or “as rolled,” sheet and strip (see X1.4).

**7.7.2** Standard flatness tolerances for plate shall conform to the requirements prescribed in Table 12. “Specially flattened” plate, when so specified, shall have permissible variations in flatness as agreed upon between the manufacturer and the purchaser.

## 8. Workmanship, Finish, and Appearance

**8.1** The material shall be uniform in quality and temper, smooth, commercially straight or flat, and free of injurious imperfections.

**8.2 Sheet, Strip, and Plate** — Sheet, strip, and plate supplied in the conditions and finishes as listed in the appendix may be ground or machined to remove surface imperfections, provided such removal does not reduce the material below the minimum specified dimensions. Surface

TABLE 10  
PERMISSIBLE VARIATIONS IN WIDTH OF SHEET AND STRIP

Specified Thickness, in. (mm)	Specified Width, in. (mm)	Permissible Variations in Specified Width, in. (mm)	
		+	-
<b>Sheet</b>			
Up to 0.250 (6.4)	all	0.125 (3.2)	0
<b>Strip<sup>4</sup></b>			
Under 0.075 (1.9)	up to 12 (305), incl	0.007 (0.18)	0.007 (0.18)
	over 12 to 48 (305 to 1219), incl	0.062 (1.6)	0
0.075 to 0.100 (1.9 to 2.5), incl	up to 12 (305), incl	0.009 (0.23)	0.009 (0.23)
	over 12 to 48 (305 to 1219), incl	0.062 (1.6)	0
Over 0.100 to 0.125 (2.5 to 3.2), incl	up to 12 (305), incl	0.012 (0.30)	0.012 (0.30)
	over 12 to 48 (305 to 1219), incl	0.062 (1.6)	0
Over 0.125 to 0.160 (3.2 to 4.1), incl	up to 12 (305), incl	0.016 (0.41)	0.016 (0.41)
	over 12 to 48 (305 to 1219), incl	0.062 (1.6)	0
Over 0.160 to 0.187 (4.1 to 4.7), incl	up to 12 (305), incl	0.020 (0.51)	0.020 (0.51)
	over 12 to 48 (305 to 1219), incl	0.062 (1.6)	0
Over 0.187 to 0.250 (4.7 to 6.4), incl	up to 12 (305), incl	0.062 (1.6)	0.062 (1.6)
	over 12 to 48 (305 to 1219), incl	0.062 (1.6)	0.062 (1.6)

<sup>4</sup> Rolled-round or square-edge strip in thicknesses of 0.071 to 0.125 in. (1.8 to 3.2 mm), inclusive, in widths 3 in. (76.2 mm) and under, shall have permissible width variations of  $\pm 0.005$  in. ( $\pm 0.130$  mm). Permissible variations for other sizes shall be as agreed upon between the manufacturer and the purchaser.

ASMENORMDOC.COM : Click to view the full PDF of ASME BPVC.II.B (ASME BPVC Section II part B) 2025

TABLE 11  
 PERMISSIBLE VARIATIONS IN LENGTH<sup>A</sup> OF SHEARED, PLASMA TORCH-CUT,<sup>B</sup> AND ABRASIVE-CUT  
 RECTANGULAR PLATE<sup>C</sup>

Specified Thickness	Permissible Variation in Length for Lengths Given, in. (mm)															
	Up to 60 (1520), incl		Over 60 to 96 (1520 to 2440), incl		Over 96 to 120 (2440 to 3050), incl		Over 120 to 240 (3050 to 6096), incl		Over 240 to 360 (6096 to 9144), incl		Over 360 to 450 (9144 to 11 430), incl		Over 450 to 540 (11 430 to 13 716), incl		Over 540 (13 716)	
	+	-	+	-	+	-	+	-	+	-	+	-	+	-	+	-
	Inches															
Sheared: <sup>D</sup>																
$\frac{3}{16}$ to $\frac{5}{16}$ , excl	$\frac{3}{16}$	$\frac{1}{8}$	$\frac{1}{4}$	$\frac{1}{8}$	$\frac{3}{8}$	$\frac{1}{8}$	$\frac{1}{2}$	$\frac{1}{8}$	$\frac{5}{8}$	$\frac{1}{8}$	$\frac{3}{4}$	$\frac{1}{8}$	$\frac{7}{8}$	$\frac{1}{8}$	...	...
$\frac{5}{16}$ to $\frac{1}{2}$ , excl	$\frac{3}{8}$	$\frac{1}{8}$	$\frac{1}{2}$	$\frac{1}{8}$	$\frac{1}{2}$	$\frac{1}{8}$	$\frac{1}{2}$	$\frac{1}{8}$	$\frac{5}{8}$	$\frac{1}{8}$	$\frac{3}{4}$	$\frac{1}{8}$	$\frac{7}{8}$	$\frac{1}{8}$	1	$\frac{1}{8}$
$\frac{1}{2}$ to $\frac{3}{4}$ , excl	$\frac{1}{2}$	$\frac{1}{8}$	$\frac{1}{2}$	$\frac{1}{8}$	$\frac{5}{8}$	$\frac{1}{8}$	$\frac{5}{8}$	$\frac{1}{8}$	$\frac{3}{4}$	$\frac{1}{8}$	$\frac{7}{8}$	$\frac{1}{8}$	$\frac{11}{8}$	$\frac{1}{8}$	$\frac{13}{8}$	$\frac{1}{8}$
$\frac{3}{4}$ to 1, excl	$\frac{5}{8}$	$\frac{1}{8}$	$\frac{5}{8}$	$\frac{1}{8}$	$\frac{5}{8}$	$\frac{1}{8}$	$\frac{3}{4}$	$\frac{1}{8}$	$\frac{7}{8}$	$\frac{1}{8}$	$\frac{1}{8}$	$\frac{1}{8}$	$\frac{1}{8}$	$\frac{1}{8}$	$\frac{15}{8}$	$\frac{1}{8}$
1 to $1\frac{1}{4}$ , incl	$\frac{3}{4}$	$\frac{1}{8}$	$\frac{3}{4}$	$\frac{1}{8}$	$\frac{3}{4}$	$\frac{1}{8}$	$\frac{7}{8}$	$\frac{1}{8}$	$1\frac{1}{8}$	$\frac{1}{8}$	$1\frac{3}{8}$	$\frac{1}{8}$	$1\frac{5}{8}$	$\frac{1}{8}$	...	...
Abrasive-cut: <sup>E</sup>																
$\frac{3}{16}$ to $1\frac{1}{4}$ , incl	$\frac{1}{8}$	$\frac{1}{8}$	$\frac{1}{8}$	$\frac{1}{8}$	$\frac{1}{8}$	$\frac{1}{8}$	$\frac{1}{8}$	$\frac{1}{8}$	$\frac{1}{8}$	$\frac{1}{8}$	$\frac{1}{8}$	$\frac{1}{8}$	...	...	...	...
Over $1\frac{1}{4}$ to $2\frac{3}{4}$ , incl	$\frac{3}{16}$	$\frac{1}{8}$	$\frac{3}{16}$	$\frac{1}{8}$	$\frac{3}{16}$	$\frac{1}{8}$	$\frac{3}{16}$	$\frac{1}{8}$	$\frac{3}{16}$	$\frac{1}{8}$	$\frac{3}{16}$	$\frac{1}{8}$	...	...	...	...
Plasma-torch-cut: <sup>F</sup>																
$\frac{3}{16}$ to 2, excl	$\frac{1}{2}$	0	$\frac{1}{2}$	0	$\frac{1}{2}$	0	$\frac{1}{2}$	0	$\frac{1}{2}$	0	$\frac{1}{2}$	0	$\frac{1}{2}$	0	$\frac{1}{2}$	0
2 to 3, incl	$\frac{5}{8}$	0	$\frac{5}{8}$	0	$\frac{5}{8}$	0	$\frac{5}{8}$	0	$\frac{5}{8}$	0	$\frac{5}{8}$	0	$\frac{5}{8}$	0	$\frac{5}{8}$	0
	Millimetres															
Sheared: <sup>D</sup>																
4.8 to 7.9, excl	4.8	3.2	6.4	3.2	9.5	3.2	12.7	3.2	15.9	3.2	19.0	3.2	22.2	3.2	...	...
7.9 to 12.7, excl	9.5	3.2	12.7	3.2	12.7	3.2	12.7	3.2	15.9	3.2	19.0	3.2	22.2	3.2	25.4	3.2
12.7 to 19.0, excl	12.7	3.2	12.7	3.2	15.9	3.2	15.9	3.2	19.0	3.2	22.2	3.2	28.6	3.2	34.9	3.2
19.0 to 25.4, excl	15.9	3.2	15.9	3.2	15.9	3.2	19.0	3.2	22.2	3.2	28.6	3.2	34.9	3.2	41.2	3.2
25.4 to 31.8, incl	19.0	3.2	19.0	3.2	19.0	3.2	22.2	3.2	28.6	3.2	34.9	3.2	41.2	3.2	...	...
Abrasive-cut: <sup>E</sup>																
4.8 to 31.8, incl	3.2	3.2	3.2	3.2	3.2	3.2	3.2	3.2	3.2	3.2	3.2	3.2	...	...	...	...
Over 31.8 to 69.9, incl	4.8	3.2	4.8	3.2	4.8	3.2	4.8	3.2	4.8	3.2	4.8	3.2	...	...	...	...
Plasma-torch-cut: <sup>F</sup>																
4.8 to 50.8, excl	12.7	0	12.7	0	12.7	0	12.7	0	12.7	0	12.7	0	12.7	0	12.7	0
50.8 to 76.2, incl	15.9	0	15.9	0	15.9	0	15.9	0	15.9	0	15.9	0	15.9	0	15.9	0

<sup>A</sup> Permissible variations in length for powder-cut or inert-arc-cut plate shall be as agreed upon between the manufacturer and the purchaser.

<sup>B</sup> The tolerance spread shown for plasma-torch-cutting may be obtained all on the minus side, or divided between the plus and minus sides if so specified by the purchaser.

<sup>C</sup> Permissible variations in machined, powder-cut or inert-arc-cut circular plate shall be as agreed upon between the manufacturer and the purchaser.

<sup>D</sup> The minimum sheared length is 10 in. (254 mm).

<sup>E</sup> Abrasive cut applicable to a maximum length of 144 to 400 in. (3658 to 10 160 mm) depending on the thickness and width ordered.

<sup>F</sup> The tolerance spread shown for plasma-torch-cut sketch plates shall be as agreed upon between the manufacturer and the purchaser.

TABLE 12  
PERMISSIBLE VARIATIONS FROM FLATNESS OF RECTANGULAR, CIRCULAR, AND SKETCH PLATES

Specified Thickness	Permissible Variations from a Flat Surface for Thickness and Widths Given in in. (mm)								
	To 48 (1220), excl	48 to 60 (1220 to 1520), excl	60 to 72 (1520 to 1830), excl	72 to 84 (1830 to 2130), excl	84 to 96 (2130 to 2440), excl	96 to 108 (2440 to 2740), excl	108 to 120 (2740 to 3050), excl	120 to 144 (3050 to 3660), excl	144 (3660), and over
Inches									
$\frac{3}{16}$ to $\frac{1}{4}$ , excl	$\frac{3}{4}$	$1\frac{1}{16}$	$1\frac{1}{4}$	$1\frac{3}{8}$	$1\frac{5}{8}$	$1\frac{5}{8}$	...	...	...
$\frac{1}{4}$ to $\frac{3}{8}$ , excl	$1\frac{1}{16}$	$\frac{3}{4}$	$1\frac{5}{16}$	$1\frac{1}{8}$	$1\frac{3}{8}$	$1\frac{7}{16}$	$1\frac{9}{16}$	$1\frac{7}{8}$	...
$\frac{3}{8}$ to $\frac{1}{2}$ , excl	$\frac{1}{2}$	$\frac{9}{16}$	$1\frac{1}{16}$	$1\frac{3}{4}$	$1\frac{5}{16}$	$1\frac{1}{8}$	$1\frac{1}{4}$	$1\frac{7}{16}$	$1\frac{3}{4}$
$\frac{1}{2}$ to $\frac{3}{4}$ , excl	$\frac{1}{2}$	$\frac{9}{16}$	$\frac{5}{8}$	$1\frac{5}{8}$	$1\frac{13}{16}$	$1\frac{1}{8}$	$1\frac{1}{8}$	$1\frac{1}{8}$	$1\frac{3}{8}$
$\frac{3}{4}$ to 1, excl	$\frac{1}{2}$	$\frac{9}{16}$	$\frac{5}{8}$	$1\frac{5}{8}$	$1\frac{3}{4}$	$1\frac{13}{16}$	$1\frac{15}{16}$	1	$1\frac{1}{8}$
1 to 2, excl	$\frac{1}{2}$	$\frac{9}{16}$	$\frac{9}{16}$	$\frac{9}{16}$	$1\frac{11}{16}$	$1\frac{11}{16}$	$1\frac{11}{16}$	$1\frac{3}{4}$	1
2 to 4, incl	$\frac{1}{4}$	$\frac{5}{16}$	$\frac{3}{8}$	$\frac{7}{16}$	$\frac{1}{2}$	$\frac{9}{16}$	$\frac{5}{8}$	$\frac{3}{4}$	$\frac{7}{8}$
Millimetres									
4.8 to 6.4, excl	19.0	27.0	31.7	34.9	41.3	41.3	...	...	...
6.4 to 9.5, excl	17.5	19.0	23.8	28.6	35.0	36.5	39.7	47.6	...
9.5 to 12.7, excl	12.7	14.3	17.5	19.0	23.8	28.6	31.7	35.0	44.4
12.7 to 19.0, excl	12.7	14.3	15.9	15.9	20.6	28.6	28.6	28.6	34.9
19.0 to 25.4, excl	12.7	14.3	15.9	15.9	19.0	20.6	23.8	25.4	28.6
25.4 to 50.8, excl	12.7	14.3	14.3	14.3	17.5	17.5	17.5	19.0	25.4
50.8 to 101.6, incl	6.4	7.9	9.5	11.1	12.7	14.3	15.9	19.0	22.2

NOTE 1 — Permissible variations apply to plates up to 12 ft (3.66 m) in length, or to any 12 ft of longer plates.

NOTE 2 — If the longer dimension is under 36 in. (914 mm), the permissible variation is not greater than  $\frac{1}{4}$  in. (6.4 mm).

NOTE 3 — The shorter dimension specified is considered the width, and the permissible variation in flatness across the width does not exceed the tabular amount of that dimension.

NOTE 4 — The maximum deviation from a flat surface does not customarily exceed the tabular tolerance for the longer dimension specified.

ASMENORMDOC.COM : Click to view the full PDF of ASME BPVC.II.B (ASME BPVC Section II part B) 2025

eliminated depressions shall be faired smoothly into the surrounding material. The removal of a surface imperfection shall be verified by the method originally used to detect the imperfection.

## 9. Sampling

**9.1 Lot** — Definition:

**9.1.1** A lot for chemical analysis shall consist of one heat.

**9.1.2** A lot for mechanical properties, hardness, and grain size testing shall consist of all material from the same heat, nominal thickness, and condition.

**9.1.2.1** Where material cannot be identified by heat, a lot shall consist of not more than 500 lb (227 kg) of material in the same thickness and condition, except for plates weighing over 500 lb, in which case only one specimen shall be taken.

**9.2 Test Material Selection:**

**9.2.1 Chemical Analysis** — Representative samples shall be taken during pouring or subsequent processing.

**9.2.1.1** Product (check) analysis shall be wholly the responsibility of the purchaser.

**9.2.2 Mechanical Properties, Hardness, and Grain Size** — Samples of the material to provide test specimens for mechanical properties, hardness, and grain size shall be taken from such locations in each lot as to be representative of that lot. (Hardness and grain size required only on the products as specified in Tables 3 and 4.)

## 10. Number of Tests

**10.1 Chemical Analysis** — One test per lot.

**10.2 Mechanical Properties** — One test per lot.

**10.3 Hardness** — One test per lot. (Required only as specified in Table 3 and Table 4.)

**10.4 Grain Size** — One test per lot. (Required only as specified in Table 4.)

## 11. Specimen Preparation

**11.1** Tension test specimens shall be taken from material in the final condition (temper) and tested transverse to the direction of rolling when width will permit.

**11.2** Tension test specimens shall be any of the standard or subsize specimens shown in Test Methods E 8.

**11.3** In the event of disagreement, referee specimens shall be as follows:

**11.3.1** Full thickness of the material, machined to the form and dimensions shown for the sheet-type specimen in Test Methods E 8 for material under  $\frac{1}{2}$  in. (12.7 mm) in thickness.

**11.3.2** The largest possible round specimen shown in Test Methods E 8 for material  $\frac{1}{2}$  in. (12.7 mm) and over.

## 12. Test Methods

**12.1** Determine the chemical composition, mechanical, and other properties of the material as enumerated in this specification, in case of disagreement, in accordance with the following methods:

Test	ASTM Designation
Chemical analysis	E 39
Tension	E 8
Brinell hardness	E 10
Rockwell hardness	E 18
Hardness conversion	E 140
Grain size	E 112
Rounding procedure	E 29
Spring-back	F 155

**12.2** The measurement of the average grain size may be carried out by the planimetric method, the comparison method, or the intercept method described in Test Methods E 112. In case of dispute, the “referee” method for determining the average grain size shall be the planimetric method.

**12.3** For purposes of determining compliance with the specified limits for requirements of the properties listed in the following table, an observed value or a calculated value shall be rounded as indicated, in accordance with the rounding method of Practice E 29.

Test	Rounded Unit for Observed Or Calculated Value
Chemical composition, hardness, and tolerances (when expressed in decimals)	nearest unit in the last right hand place of figures of the specified limit. If two choices are possible, as when the digits dropped are exactly a 5, or a 5 followed only by zeros, choose the one ending in an even digit, with zero defined as an even digit.
Tensile strength and yield strength	nearest 1000 psi (6.9 MPa)
Elongation	nearest 1%
Grain Size:	
0.0024 in. (0.060 mm) or larger	nearest multiple of 0.0002 in. (0.005 mm)
less than 0.0024 in. (0.060 mm)	nearest multiple of 0.0001 in. (0.002 mm)

## 13. Inspection

**13.1** Inspection of the material shall be as agreed upon between the purchaser and the supplier as part of the purchase contract.

#### 14. Rejection and Rehearing

**14.1** Material that fails to conform to the requirements of this specification may be rejected. Rejection should be reported to the producer or supplier promptly and in writing. In case of dissatisfaction with the results of the test, the producer or supplier may make claim for a rehearing.

#### 15. Certification

**15.1** A manufacturer's certification shall be furnished to the purchaser stating that material has been manufactured, tested, and inspected in accordance with this specification, and that the test results on representative samples meet specification requirements. A report of the test results shall be furnished.

#### 16. Product Marking

**16.1** Each plate, sheet, or strip shall be marked on one face with the specification number, alloy, condition (temper), heat number, manufacturer's identification, and size. The markings shall not have a deleterious effect on the material or its performance and shall be sufficiently stable to withstand normal handling.

**16.2** When applicable, each bundle or shipping container shall be marked with the name of the material, condition (temper), this specification number, alloy, size, consignor and consignee address, contract or order number, and such other information as may be defined in the contract or order.

ASME BPVC Section II part B) 2025  
ASME BPVC.II.B (ASME BPVC Section II part B) 2025  
Click to view the full PDF of ASME BPVC.II.B (ASME BPVC Section II part B) 2025

## APPENDIX

## (Nonmandatory Information)

**X1. CONDITIONS AND FINISHES****X1.1 Scope**

**X1.1.1** This appendix lists the conditions and finishes in which plate, sheet, and strip are normally supplied. These are subject to change, and the manufacturer should be consulted for the latest information available.

**X1.2 Plate, Hot-Rolled**

**X1.2.1** *Annealed* — Soft with an oxide surface, and suitable for heavy cold forming. Available with a descaled surface, when so specified.

**X1.2.2** *As-Rolled* — With an oxide surface. Available with a descaled surface, when so specified. Suitable for flat work, mild forming or tube sheets. When intended for tube sheets, specify that plates are to be specially flattened. When intended for hot forming, this should be indicated on the purchase order so that the manufacturer may select appropriate material.

**X1.3 Plate, Cold-Rolled**

**X1.3.1** *Annealed* — Soft with an oxide surface; available with a descaled surface when so specified.

**X1.4 Sheet, Hot-Rolled**

**X1.4.1** *Annealed and Pickled* — Soft with a pickled matte finish. Properties similar to X1.5.1 but with broader thickness tolerances. Not suggested for applications where the finish of a cold-rolled sheet is considered essential or for deep drawing or spinning.

**X1.5 Sheet and Strip, Cold-Rolled**

**X1.5.1** *Annealed* — Soft with a pickled or bright annealed finish.

**X1.5.2** *Deep-Drawing or Spinning Quality* — Similar to X1.5.1, except furnished to controlled hardness and grain size and lightly leveled.

**X1.5.3** *Skin Hard* — Similar to X1.5.1, but given a light cold reduction to hardness range shown in Table 3.

**X1.5.4** *Quarter-Hard* — Cold rolled to the hardness range indicated in Table 3, bright finish. Out-of-flatness must be expected and will vary with temper and thickness.

**X1.5.5** *Half-Hard* — Cold rolled to the hardness range indicated in Table 3, bright finish. Out-of-flatness must be expected and will vary with temper and thickness.

**X1.5.6** *Three-Quarter Hard* — Cold rolled to the hardness range indicated in Table 3, bright finish. Out-of-flatness must be expected and will vary with temper and thickness.

**X1.5.7** *Hard* — Cold rolled to the tensile requirements indicated in Table 3, bright finish. Out-of-flatness must be expected and will vary with temper and thickness.

**X1.5.8** *Spring Temper* — Cold rolled to the minimum hardness indicated in Table 3, bright finish. Out-of-flatness must be expected and will vary with temper and thickness.

ASMENORMDOC.COM : Click to view the full PDF of ASME BPVC.II.B (ASME BPVC Section II part B) 2025

INTENTIONALLY LEFT BLANK

# SPECIFICATION FOR SEAMLESS NICKEL AND NICKEL ALLOY CONDENSER AND HEAT-EXCHANGER TUBES



**SB-163**

(Identical with ASTM Specification B163-19 except that certification and test reports have been made mandatory.)

ASMENORMDOC.COM : Click to view the full PDF of ASME BPVC.II.B (ASME BPVC Section II part B) 2025

# Specification for Seamless Nickel and Nickel Alloy Condenser and Heat- Exchanger Tubes

## 1. Scope

1.1 This specification covers seamless tubes of nickel and nickel alloys, as shown in Table 1, for use in condenser and heat-exchanger service.

1.2 This specification covers outside diameter and average wall, or outside diameter and minimum wall tube.

1.2.1 The sizes covered by this specification are 3 in. (76.2 mm) and under in outside diameter with minimum wall thicknesses of 0.148 in. (3.76 mm) and under, and with average wall thicknesses of 0.165 in. (4.19 mm) and under.

1.3 Tube shall be furnished in the alloys and conditions as shown in Table 2. For small diameter and light wall tube (converter sizes), see Appendix X2.

1.4 The values stated in inch-pound units are to be regarded as standard. The values given in parentheses are mathematical conversions to SI units that are provided for information only and are not considered standard.

1.5 The following safety hazards caveat pertains only to the test method portion, Section 12, of this specification. *This standard does not purport to address all of the safety concerns, if any, associated with its use. It is the responsibility of the user of this standard to become familiar with all hazards including those identified in the appropriate Safety Data Sheet (SDS) for this product/material as provided by the manufacturer, to establish appropriate safety, health, and environmental practices, and determine the applicability of regulatory limitations prior to use.*

1.6 *This international standard was developed in accordance with internationally recognized principles on standardization established in the Decision on Principles for the Development of International Standards, Guides and Recom-*

*mendations issued by the World Trade Organization Technical Barriers to Trade (TBT) Committee.*

## 2. Referenced Documents

### 2.1 ASTM Standards:

B829 Specification for General Requirements for Nickel and Nickel Alloys Seamless Pipe and Tube

B880 Specification for General Requirements for Chemical Check Analysis Limits for Nickel, Nickel Alloys and Cobalt Alloys

E8/E8M Test Methods for Tension Testing of Metallic Materials

E18 Test Methods for Rockwell Hardness of Metallic Materials

E29 Practice for Using Significant Digits in Test Data to Determine Conformance with Specifications

E76 Test Methods for Chemical Analysis of Nickel-Copper Alloys (Withdrawn 2003)

E112 Test Methods for Determining Average Grain Size

E140 Hardness Conversion Tables for Metals Relationship Among Brinell Hardness, Vickers Hardness, Rockwell Hardness, Superficial Hardness, Knoop Hardness, Scleroscope Hardness, and Leeb Hardness

E1473 Test Methods for Chemical Analysis of Nickel, Cobalt and High-Temperature Alloys

### 2.2 Federal Standards:

Fed. Std. No. 102 Preservation, Packaging and Packing Levels

Fed. Std. No. 123 Marking for Shipment (Civil Agencies)

Fed. Std. No. 182 Continuous Identification Marking of Nickel and Nickel-Base Alloys

### 2.3 Military Standard:

MIL-STD-129 Marking for Shipment and Storage

TABLE 1 Chemical Requirements<sup>A</sup>

	Composition, %									
	N02200	N02201	N04400	N06025	N06045	N06600	N06601	N06603	N06686	N06690
Nickel	99.0 min <sup>B</sup>	99.0 min <sup>B</sup>	63.0 min <sup>B</sup>	remainder <sup>B</sup>	45.0 min <sup>B</sup>	72.0 min <sup>B</sup>	58.0–63.0	remainder <sup>B</sup>	remainder <sup>B</sup>	58.0 min <sup>B</sup>
Copper	0.25	0.25	28.0–34.0	0.1	0.3	0.5	1.0	0.5	...	0.5
Molybdenum	...	...	...	...	...	...	...	...	15.0–17.0	...
Iron	0.40	0.40	2.5	8.0–11.0	21.0–25.0	6.0–10.0	remainder <sup>B</sup>	8.0–11.0	5.0	7.0–11.0
Manganese	0.35	0.35	2.0	0.15	1.0	1.0	1.0	0.15	0.75	0.5
Carbon	0.15	0.02	0.3	0.15–0.25	0.05–0.12	0.15	0.10	0.20–0.40	0.010	0.05
Silicon	0.35	0.35	0.5	0.5	2.5–3.0	0.5	0.5	0.5	0.08	0.5
Sulfur	0.01	0.01	0.024	0.010	0.010	0.015	0.015	0.010	0.02	0.015
Chromium	...	...	...	24.0–26.0	26.0–29.0	14.0–17.0	21.0–25.0	24.0–26.0	19.0–23.0	27.0–31.0
Aluminum	...	...	...	1.8–2.4	...	...	1.0–1.7	2.4–3.0	...	...
Titanium	...	...	...	0.1–0.2	...	...	...	0.01–0.25	0.02–0.25	...
Phosphorus	...	...	...	0.020	0.020	...	...	0.02	0.04	...
Cerium	...	...	...	...	0.03–0.09	...	...	...	...	...
Zirconium	...	...	...	0.01–0.10	...	...	...	0.01–0.10	...	...
Yttrium	...	...	...	0.05–0.12	...	...	...	0.01–0.15	...	...
Boron	...	...	...	...	...	...	...	...	...	...
Cobalt	...	...	...	...	...	...	...	...	...	...
Columbium (Nb)	...	...	...	...	...	...	...	...	...	...
Tungsten	...	...	...	...	...	...	...	...	3.0–4.4	...
Nitrogen	...	...	...	...	...	...	...	...	...	...

<sup>A</sup> Maximum unless range or minimum is given. Where ellipses (...) appear in this table, there is no requirement and analysis for the element need not be determined or reported.

<sup>B</sup> Element shall be determined arithmetically by difference.

TABLE 1 Chemical Requirements<sup>A</sup> (continued)

	N06696	N06699	N06845	N08120	N08800	N08801	N08810	N08811	N08825	N08935
Nickel	remainder <sup>B</sup>	remainder <sup>B</sup>	44.0–50.0	35.0–39.0	30.0–35.0	30.0–34.0	30.0–35.0	30.0–35.0	38.0–46.0	34.0–36.0
Copper	1.5–3.0	0.50	2.0–4.0	0.50	0.75	0.50	0.75	0.75	1.5–3.0	0.4
Molybdenum	1.0–3.0	...	5.0–7.0	2.50	...	...	...	...	2.5–3.5	6.1–7.1
Iron	2.0–6.0	2.5	remainder <sup>B</sup>	remainder <sup>B</sup>	39.5 min <sup>B</sup>	39.5 min <sup>B</sup>	39.5 min <sup>B</sup>	39.5 min <sup>B</sup>	22.0 min <sup>B</sup>	remainder <sup>B</sup>
Manganese	1.0	0.50	0.5	1.5	1.5	1.50	1.5	1.5	1.0	1.2
Carbon	0.15	0.005–0.10	0.05	0.02–0.10	0.10	0.10	0.05–0.10	0.06–0.10	0.05	0.030
Silicon	1.0–2.5	0.50	0.5	1.0	1.0	1.00	1.0	1.0	0.5	0.5
Sulfur	0.010	0.01	0.010	0.03	0.015	0.015	0.015	0.015	0.03	0.020
Chromium	28.0–32.0	26.0–30.0	20.0–25.0	23.0–27.0	19.0–23.0	19.0–22.0	19.0–23.0	19.0–23.0	19.5–23.5	26.0–28.0
Aluminum	...	1.9–3.0	...	0.40	0.15–0.60	...	0.15–0.60	0.15–0.60 <sup>C</sup>	0.2	...
Titanium	1.0	0.60	...	0.20	0.15–0.60	0.75–1.5	0.15–0.60	0.15–0.60 <sup>C</sup>	0.6–1.2	...
Phosphorus	...	0.02	...	0.04	...	...	...	...	...	0.030
Cerium	...	...	...	...	...	...	...	...	...	...
Zirconium	...	0.10	...	...	...	...	...	...	...	...
Yttrium	...	...	...	...	...	...	...	...	...	...
Boron	...	0.008	...	0.010	...	...	...	...	...	...
Cobalt	...	...	...	3.0	...	...	...	...	...	...
Columbium (Nb)	...	0.50	...	0.4–0.9	...	...	...	...	...	...
Tungsten	...	...	2.0–5.0	2.50	...	...	...	...	...	...
Nitrogen	...	0.05	...	0.13–0.30	...	...	...	...	...	0.25–0.36

<sup>A</sup> Maximum unless range or minimum is given. Where ellipses (...) appear in this table, there is no requirement and analysis for the element need not be determined or reported.

<sup>B</sup> Element shall be determined arithmetically by difference.

<sup>C</sup> Alloy UNS N08811: Al + Ti, 0.85 – 1.20.

ASME NORMDOC.COM : Click to view the full PDF of ASME BPVC.II.B (ASME BPVC Section II part B) 2025

TABLE 2 Alloy and Conditions

Alloy	Condition
Nickel UNS N02200 and low-carbon nickel UNS N02201	annealed or stress-relieved
Nickel-copper alloy UNS N04400	annealed or stress-relieved
Nickel-chromium-iron-aluminum alloy UNS N06603	annealed
Nickel-chromium-iron-copper alloy UNS N06696	annealed
Nickel-chromium-iron-aluminum alloy UNS N06601	annealed
Nickel-chromium-iron alloy UNS N06600	annealed
Low-carbon nickel-chromium-molybdenum-tungsten alloy UNS N06686	annealed
Nickel-chromium-iron alloy UNS N06690	annealed
Nickel-chromium-iron alloy UNS N06045	annealed
Nickel-iron-chromium alloy UNS N08120 <sup>A</sup>	annealed or cold-worked
Nickel-iron-chromium alloy UNS N08800 <sup>A</sup>	annealed or cold-worked
Nickel-iron-chromium alloy UNS N08810 <sup>A</sup>	annealed
Nickel-iron-chromium alloy UNS N08811 <sup>A</sup>	annealed
Nickel-iron-chromium alloy UNS N08801	annealed
Nickel-iron-chromium-molybdenum alloy UNS N08935	annealed
Nickel-iron-chromium-molybdenum-copper alloy UNS N08825	annealed
Nickel-chromium-iron alloy UNS N06025	annealed
Nickel-iron-chromium-molybdenum-copper alloy UNS N06845	annealed
Nickel-chromium-aluminum alloy UNS N06699	annealed

<sup>A</sup> Alloy UNS N08800 is normally employed in service temperatures up to and including 1100°F (593°C). Alloys UNS N08810, UNS N08811, and UNS N08120 are normally employed in service temperatures above 1100°F (593°C) where resistance to creep and rupture is required, and it is annealed to develop controlled grain size for optimum properties in this temperature range.

### 3. Terminology

#### 3.1 Definitions:

3.1.1 *average diameter, n*—average of the maximum and minimum outside diameters, as determined at any one cross section of the tube.

3.1.2 *tube, n*—hollow product of round or any other cross section having a continuous periphery.

### 4. Ordering Information

4.1 It is the responsibility of the purchaser to specify all requirements that are necessary for the safe and satisfactory performance of material ordered under this specification. Examples of such requirements include, but are not limited to, the following:

4.1.1 *Alloy* (Table 1).

4.1.2 *Condition (Temper)* Table 3 and Appendix X1 and Appendix X2.

4.1.2.1 If annealed ends for stress relieved tubing are desired, state length of end to be annealed and whether or not one end or both ends are to be annealed.

4.1.3 *Finish*.

4.1.4 *Dimensions*—Outside diameter, minimum or average wall thickness (in inches, not gage number), and length.

4.1.5 *Fabrication Operations:*

4.1.5.1 *Cold Bending or Coiling.*

4.1.5.2 *Packing.*

4.1.5.3 *Rolling or Expanding into Tube Sheets.*

4.1.5.4 *Welding or Brazing*—Process to be employed.

4.1.5.5 *Hydrostatic Test or Nondestructive Electric Test*—Specify type of test (6.5).

4.1.5.6 *Pressure Requirements*—If other than required by 6.5.

4.1.5.7 *Ends*—Plain ends cut and deburred will be furnished.

4.1.6 *Supplementary Requirements*—State nature and details.

4.1.7 DELETED

4.1.8 *Samples for Product (Check) Analysis*—Whether samples for product (check) analysis shall be furnished.

4.1.9 *Purchaser Inspection*—If purchaser wishes to witness tests or inspection of material at place of manufacture, the purchase order must so state indicating which tests or inspections are to be witnessed (Section 13).

4.1.10 *Small-Diameter and Light-Wall Tube (Converter Sizes)*—See Appendix X2.

### 5. Chemical Composition

5.1 The material shall conform to the composition limits specified in Table 1.

5.2 If a product (check) analysis is performed by the purchaser, the material shall conform to the product (check) analysis per Specification B880.

### 6. Mechanical Properties and Other Requirements

6.1 *Mechanical Properties*—The material shall conform to the mechanical properties specified in Table 3.

6.2 *Hardness*—When annealed ends are specified for tubing in the stress-relieved condition (see Table 3), the hardness of the ends after annealing shall not exceed the values specified in Table 3.

6.3 *Flare*—A flare test shall be made on one end of 1 % of the number of finished tube lengths from each lot. For less than 100 tubes in a lot, a flare test shall be made on one end of one tube length in the lot. In the case of stress relieved tubing with annealed ends, the test shall be made prior to, or subsequent to, annealing of the ends at the option of the manufacturer.

6.3.1 The flare test shall consist of flaring a test specimen with an expanding tool having an included angle of 60° until the specified outside diameter has been increased by 30 %. The flared specimen shall not exhibit cracking through the wall.

6.4 *Grain Size*—A transverse sample representing full-wall thickness of annealed alloys UNS N08120, UNS N08810 and UNS N08811 shall conform to an average grain size of ASTM No. 5 or coarser.

TABLE 3 Mechanical Properties of Tubes

Material and Condition	Tensile Strength, min, ksi (MPa)	Yield Strength (0.2 % Offset), min, ksi (MPa)	Elongation in 2 in. or 50 mm (or 4 D) min, %	Rockwell Hardness (or equivalent) for annealed ends <sup>4</sup>
<i>Nickel UNS N02200:</i>				
Annealed	55 (379)	15 (103)	40	...
Stress-relieved	65 (448)	40 (276)	15	B65 max
<i>Low-carbon nickel UNS N02201:</i>				
Annealed	50 (345)	12 (83)	40	...
Stress-relieved	60 (414)	30 (207)	15	B62 max
<i>Nickel-copper alloy UNS N04400:</i>				
Annealed	70 (483)	28 (193)	35	...
Stress-relieved	85 (586)	55 (379)	15	B75 max
<i>Nickel-chromium-iron alloys:</i>				
Annealed alloy UNS N06600	80 (552)	35 (241)	30	...
Annealed alloy UNS N06601	80 (552)	30 (207)	30	...
Annealed alloy UNS N06690	85 (586)	35 (241)	30	...
Annealed alloy UNS N06045	90 (620)	35 (240)	35	...
Annealed alloy UNS N06025	98 (680)	39 (270)	30	...
Annealed alloy UNS N06603	94 (650)	43 (300)	25	...
Annealed alloy UNS N06696	85 (586)	35 (240)	30	...
<i>Low-carbon nickel-chromium-molybdenum-tungsten alloy:</i>				
Annealed UNS N06686	100 (690)	45 (310)	45	...
<i>Nickel-iron-chromium alloys:</i>				
Annealed alloy UNS N08120	90 (620)	40 (276)	30	...
Annealed alloy UNS N08800	75 (517)	30 (207)	30	...
Annealed alloy UNS N08801	65 (448)	25 (172)	30	...
Cold-worked alloy UNS N08800	83 (572)	47 (324)	30	...
Annealed alloy UNS N08810	65 (448)	25 (172)	30	...
Annealed alloy UNS N08811	65 (448)	25 (172)	30	...
<i>Nickel-iron-chromium-molybdenum alloy:</i>				
Annealed alloy UNS N08935	109 (750)	62 (425)	35	...
<i>Nickel-iron-chromium-molybdenum-copper alloys:</i>				
Annealed UNS N08825	85 (586)	35 (241)	30	...
Annealed UNS N06845	100 (690)	40 (276)	30	...
<i>Nickel-chromium-aluminum alloys:</i>				
Annealed UNS N06699	89 (610)	35 (240)	40	...

<sup>4</sup> Rockwell or equivalent hardness values apply only to the annealed ends of stress-relieved tubing. Caution should be observed in using the Rockwell test on thin material, as the results may be affected by the thickness of specimen. For thickness under 0.050 in. (1.27 mm) the use of the Rockwell superficial or the Vickers hardness test is suggested. For hardness conversions for nickel and high-nickel alloys see Hardness Conversion Tables E140.

6.5 *Hydrostatic or Nondestructive Electric Test*—Each tube shall be subjected to either the hydrostatic test or the nondestructive electric test. The type of test to be used shall be at the option of the manufacturer, unless otherwise specified in the purchase order.

6.5.1 *Hydrostatic Test:*

6.5.1.1 Each tube with an outside diameter 1/8 in. (3.2 mm) and larger and tubes with wall thickness of 0.015 in. (0.38 mm) and over shall be tested by the manufacturer to an internal hydrostatic pressure of 1000 psi (6.9 MPa) provided that the fiber stress calculated in accordance with the following equation does not exceed the allowable fiber stress, *S*, indicated below. The tube shall show no evidence of leakage.

$$P = 2St/D$$

where:

- P* = hydrostatic test pressure, psi (MPa),
- S* = allowable fiber stress for material in the condition furnished, as follows:
- t* = minimum wall thickness, in. (mm); equal to the specified average wall minus the permissible “minus” wall tolerance, Table 4 and Table X2.2, or the specified minimum wall thickness, and
- D* = outside diameter of the tube, in. (mm).

	psi	MPa
Annealed low-carbon nickel UNS N02201	8 000	55.2
Stress-relieved low-carbon nickel UNS N02201	15 000	103.4
Annealed nickel UNS N02200	10 000	68.9
Stress-relieved nickel UNS N02200	16 200	111.7
Annealed nickel-copper alloy UNS N04400	17 500	120.6
Stress-relieved nickel-copper alloy UNS N04400	21 200	146.2
Annealed nickel-chromium-aluminum alloy UNS N06699	22 100	152
Annealed nickel-chromium-iron alloy UNS N06600	20 000	137.9
Annealed nickel-chromium-iron alloy UNS N06601	20 000	137.9
Annealed nickel-chromium-iron alloy UNS N06690	21 200	146
Annealed nickel-chromium-iron alloy UNS N06045	22 500	155
Annealed nickel-chromium-iron alloy UNS N06025	24 500	169
Solution annealed low-carbon nickel-chromium-molybdenum-tungsten alloy UNS N06686	25 000	172
Annealed nickel-chromium-iron-aluminum alloy UNS N06603	24 000	165
Annealed nickel-chromium-iron-copper alloy UNS N06696	21 200	146
Annealed nickel-iron-chromium alloy UNS N08120	22 500	155
Annealed nickel-iron-chromium alloy UNS N08800	18 700	128.9
Annealed nickel-iron-chromium alloy UNS N08810	16 600	114.4
Annealed nickel-iron-chromium alloy UNS N08811	16 600	114.4
Annealed nickel-iron-chromium alloy UNS N08801	16 600	114.4
Annealed nickel-iron-chromium-molybdenum alloy UNS N08935	27 200	187.5
Annealed nickel-iron-chromium-molybdenum copper alloy UNS N08825	21 000	144.8
Annealed nickel-iron-chromium-molybdenum-copper alloy UNS N06845	21 200	146.2
Cold-worked nickel-iron-chromium alloy UNS N08800	20 700	142.7

**TABLE 4 Permissible Variations in Outside Diameter and Wall Thickness of Condenser and Heat Exchanger Tubes**

NOTE 1—The tolerances in the table apply to individual measurements of outside diameter and include out-of-roundness (ovality), and apply to all materials and all conditions, except that for thin wall tubes having a nominal wall of 3 % or less of the outside diameter, the mean outside diameter shall comply with the permissible variations of the above table and individual measurements (including ovality) shall conform to the plus and minus values of the table with the values increased by ½ % of the nominal outside diameter.

NOTE 2—*Eccentricity*—The variation in wall thickness in any one cross section of any one tube shall not exceed plus or minus 10 % of the actual (measured) average wall of that section. The actual average wall is defined as the average of the thickest and thinnest wall of that section.

NOTE 3—For tolerances of small diameter and light wall tube (converter sizes) see Appendix X2 (Table X2.2).

Material	Nominal Outside Diameter, in. (mm)	Permissible Variations <sup>A</sup>					
		Outside Diameter, in. (mm)		Wall Thickness, %			
		+	-	Average Wall		Minimum Wall	
				+	-	+	-
UNS N02200, UNS N02201, and UNS N04400	½ to ⅝ (12.7 to 15.9), excl	0.005 (0.13)	0	12.5	12.5	25.0	0
	⅝ to 1½ (15.9 to 38.1), incl	0.005 (0.13)	0.005 (0.13)	10.0	10.0	20.0	0
	over 1½ to 3 (38.1 to 76.2), incl	0.010 (0.25)	0.010 (0.25)	10.0	10.0	22.0	0
UNS N06600, UNS N06601, UNS N06690, UNS N06045, UNS N06025, UNS N06603, UNS N06696, UNS N08800, UNS N06699, UNS N08810, UNS N08811, UNS N08801, UNS N08935, UNS N08825, UNS N06845, and UNS N08120	½ to ⅝ (12.7 to 15.9), excl	0.005 (0.13)	0.005 (0.13)	12.5	12.5	25.0	0
	⅝ to 1½ (15.9 to 38.1), incl	0.0075 (0.19)	0.0075 (0.19)	10.0	10.0	20.0	0
UNS N06686	over 1½ to 3 (38.1 to 76.2), incl	0.010 (0.25)	0.010 (0.25)	10.0	10.0	22.0	0

<sup>A</sup> Wall variations as indicated above are applicable only to the wall as ordered, for instance, to minimum or to average wall, but not to both.

6.5.1.2 When so agreed upon between the manufacturer and the purchaser, tube may be tested to 1½ times the above allowable fiber stress.

6.5.1.3 When stress-relieved tubes with annealed ends are to be tested hydrostatically, such pressure testing shall be done prior to annealing of the ends of the tube.

6.5.2 *Nondestructive Electric Test*—Each tube shall be examined with a nondestructive electric test as prescribed in Specification B829.

**7. Dimensions and Permissible Variations**

7.1 *Outside Diameter and Wall Thickness*—The permissible variations in the outside diameter and wall thickness of tube shall not exceed those prescribed in Table 4 and Table X2.2, as applicable. (See also Table 5 and Table 6.)

7.2 *Length*—When tube is ordered cut-to-length, the length shall not be less than that specified, but a variation of plus ⅛ in. (3.2 mm) will be permitted, except that for lengths over 30 ft (9.1 m), a variation of plus ¼ in. (6.4 mm) will be permitted.

7.3 *Straightness*—Material shall be reasonably straight and free of bends or kinks.

**8. Workmanship, Finish, and Appearance**

8.1 The material shall be uniform in quality and temper, smooth, commercially straight, and free of injurious imperfections.

**9. Sampling**

9.1 *Lot*—Definition:

9.1.1 A lot for chemical analysis shall consist of one heat.

**TABLE 5 Alloy,<sup>A</sup> Condition, Tube Size, and Bend Radii Limitations**

Tube OD, in. (mm)	Average Tube Wall, in. (mm) <sup>B</sup>	Minimum Bend Radius, in. (mm)	
		Annealed Condition	Stress-Relieved Condition
Up to ½ (12.7), incl	0.046 to 0.057 (1.17 to 1.45), incl	1¼ (31.8)	1¼ (31.8)
Up to ½ (12.7), incl	Over 0.057 to 0.120 (1.45 to 3.05), incl	1 (25.4)	1⅝ (28.6)
Over ½ to ⅝ (12.7 to 15.9), incl	0.037 to 0.057 (0.94 to 1.45), incl	1¼ (30.2)	1¼ (31.8)
Over ½ to ⅝ (12.7 to 15.9), incl	Over 0.057 to 0.120 (1.45 to 3.05), incl	1 (25.4)	1⅝ (30.2)
Over ⅝ to ¾ (15.9 to 19.0), incl	0.049 to 0.057 (1.24 to 1.45), incl	1¼ (31.8)	1½ (38.1)
Over ⅝ to ¾ (15.9 to 19.0), incl	Over 0.057 to 0.109 (1.45 to 2.77), incl	1⅝ (30.2)	1¼ (31.8)
Over ¾ to 1 (19.0 to 25.4), incl	0.049 to 0.058 (1.24 to 1.47), incl	2 (50.8)	4 (101.6)
Over ¾ to 1 (19.0 to 25.4), incl	Over 0.058 to 0.109 (1.47 to 2.77), incl	1¾ (44.5)	2¼ (57.2)

<sup>A</sup> Applies for all alloys except alloy UNS N08810, alloy UNS N08801, and UNS N08811.

<sup>B</sup> To determine the bend radius applicable to minimum wall tubing, compute the corresponding average wall from the wall tolerances in Table 4, then use Table 5.

TABLE 6 Alloys, Size Ranges, and Yield Strength for Higher Yield Strength Tubes

Alloys	Size Range, in. (mm)		0.2 % Yield Strength, ksi (MPa)	
	OD	Wall Thickness	Minimum	Maximum
Nickel-chromium-iron Alloy UNS N06600	¼ to ⅞ (6.35 to 22.23)	Up to 0.100 (2.54)	40 (276)	65 (448)
Nickel-chromium-iron Alloy UNS N06601	¼ to ⅞ (6.35 to 22.23)	Up to 0.100 (2.54)	40 (276)	65 (449)
Nickel-iron-chromium Alloy UNS N08800	¼ to ⅞ (6.35 to 22.23)	Up to 0.100 (2.54)	40 (276)	65 (448)
Nickel-chromium-iron Alloy UNS N06690	¼ to ⅞ (6.35 to 22.23)	Up to 0.100 (2.54)	40 (276)	65 (448)

9.1.2 A lot for mechanical properties, hardness, flaring, and grain size testing shall consist of all material from the same heat, nominal size (except length), and condition (temper).

9.1.2.1 Where material cannot be identified by heat, a lot shall consist of not more than 500 lb (230 kg) of material in the same condition (temper) and size.

### 9.2 Test Material Selection:

9.2.1 *Chemical Analysis*—Representative samples shall be taken during pouring or subsequent processing.

9.2.1.1 Product (check) analysis shall be wholly the responsibility of the purchaser.

9.2.2 *Mechanical Properties, Hardness, and Grain Size*—Samples of the material to provide test specimens for mechanical properties, hardness, and grain size shall be taken from such locations in each lot as to be representative of that lot.

## 10. Number of Tests

10.1 *Chemical Analysis*—One test per lot.

10.2 *Mechanical Properties*—One test per lot.

10.3 *Hardness*—A representative sample consisting of 3 % of each lot of tubes with annealed ends (see 9.1.2).

10.4 *Grain Size*—One test per lot.

10.5 *Flare*—A representative sample consisting of 1 % of the number of tube lengths in each lot, with a minimum of one tube per lot.

## 11. Specimen Preparation

### 11.1 Tension Test:

11.1.1 Tension test specimens shall be taken from material in the final condition (temper) and tested in the direction of fabrication.

11.1.2 Whenever possible, all tubes shall be tested in full tubular size. When testing in full tubular size is not possible, longitudinal strip specimens, or the largest possible round specimen, shall be used. In the event of disagreement when full tubular testing is not possible, a longitudinal strip specimen with reduced gage length as contained in Test Methods E8/E8M shall be used.

11.1.3 In the case of stress-relieved tubes furnished with annealed ends, the tension test shall be made on the stress-relieved tubes prior to annealing the ends.

### 11.2 Hardness Test:

11.2.1 *Stress-Relieved Tubing with Annealed Ends*—The hardness test may be made on the inside of the tube near the end or on a specimen cut from the end, at the option of the manufacturer. The test shall be made on the inside of the specimen.

## 12. Test Methods

12.1 The chemical composition, mechanical, and other properties of the material as enumerated in this specification shall be determined, in case of disagreement, in accordance with the following methods:

Test	ASTM Designation
Chemical Analysis	E76, E1473
Tension	E8/E8M
Rounding Procedure	E29
Rockwell Hardness	E18
Grain Size	E112
Hardness Conversion	E140

12.2 The measurement of average grain size may be carried out by the planimetric method, the comparison method, or the intercept method described in Test Methods E112. In case of dispute the “referee” method for determining average grain size shall be the planimetric method.

12.3 For purposes of determining compliance with the specified limits for requirements of the properties listed in the following table, an observed value or a calculated value shall be rounded as indicated below, in accordance with the rounding method of Practice E29:

Test	Rounded Unit for Observed or Calculated Value
Chemical composition, hardness, and tolerances (when expressed in decimals)	nearest unit in the last right-hand place of figures of the specified limit
Tensile strength, yield strength	nearest 1000 psi (6.9 MPa)
Elongation	nearest 1 %
Grain size:	
0.0024 in. (0.060 mm) or larger	nearest multiple of 0.0002 in. (0.005 mm)
less than 0.0024 in. (0.060 mm)	nearest multiple of 0.0001 in. (0.002 mm)

## 13. Inspection

13.1 Inspection of the material shall be made as agreed upon between the manufacturer and the purchaser as part of the purchase contract.

## 14. Rejection and Rehearing

14.1 Material not conforming to this specification or to authorized modifications will be subject to rejection.

14.2 Samples tested in accordance with this specification that represent rejected material shall be preserved for not less than three weeks from the date of the test report. In case of dissatisfaction with the results of the tests, the manufacturer may make claim for a rehearing within that time.

## 15. Certification

15.1 A manufacturer’s certification shall be furnished to the purchaser stating that material has been manufactured, tested and inspected in accordance with this specification, and that the test results on representative samples meet specification

requirements. A report of the test results shall be furnished.

**16. Product Marking**

16.1 Each bundle or shipping container shall be marked with the name of the material; condition (temper); this specification number; the size; gross, tare, and net weight; consignor and consignee address; contract or order number; or such other information as may be defined in the contract or order.

**17. Keywords**

17.1 seamless tube; UNS N02200; UNS N02201; UNS N04400; UNS N06025; UNS N06045; UNS N06600; UNS N06601; UNS N06603; UNS N06686; UNS N06690; UNS N06696; UNS N06845; UNS N08120; UNS N08800; UNS N08801; UNS N08810; UNS N08811; UNS N08825; UNS N06699; UNS N08935

**SUPPLEMENTARY REQUIREMENTS**

**S1. U-BENT TUBES**

The following supplementary requirements shall apply when U-bent tubes are specified by the purchaser in the inquiry, contract, or order.

**S1.1 Limitation of Supplementary Requirements for U-Bent Tubes**

S1.1.1 The requirements for U-bent tubes included in this supplement are limited to the alloys, conditions (tempers), tube outside diameter (OD), and wall thickness ranges and bend radii listed in Table 5.

**S1.2 Permissible Variations in Dimensions (Fig. S1.1)**

S1.2.1 *Leg Spacing*—The leg spacing, measured between the points of tangency of the bend to the legs shall not vary from the value (2R – specified tube OD) by more than the amounts shown below where R is the specified centerline bend radius:

Centerline Bend Radius (R), in. (mm)	Tolerance, in. (mm)
Up to 18 (457), incl.	1/16 (1.6)
Over 18 to 30 (457 to 762), incl.	3/32 (2.4)
Over 30 to 36 (762 to 914), incl.	1/8 (3.2)

S1.2.2 *Diameter of Tube in U-Bent Section*—Neither the major, nor the minor outside diameter of the tube at any one cross section included within the points of tangency of the bend shall deviate from the nominal diameter prior to bending by more than 10 %.

S1.2.3 *Wall Thickness of Tube in U-Bent Section*—The wall thickness of the tube at the apex of the U-bent section shall be not less than the value determined by the following equation:

$$TF = T(2R)/(2R + D)$$

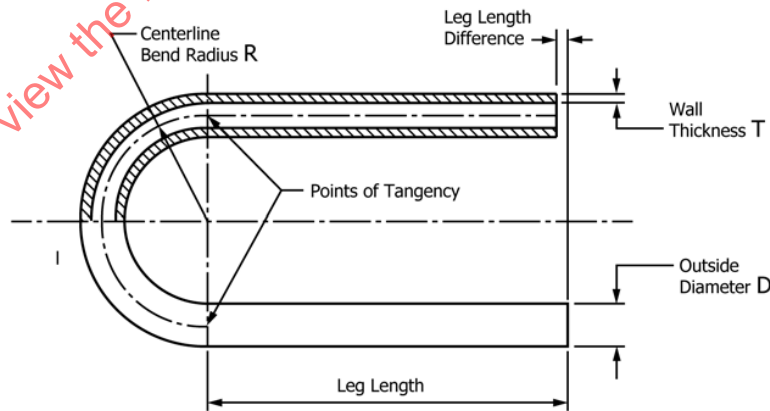

FIG. S1.1 Bent Portion of U-Tube

where:

- $TF$  = thickness after bending, in. (mm),  
 $T$  = minimum permissible thickness of tube wall prior to bending, in. (mm),  
 $R$  = centerline bend radius, in. (mm), and  
 $D$  = nominal outside diameter of the tube, in. (mm).

When specified by the purchaser, proof of conformance to this requirement shall be obtained by bending a tube specimen, representative of the material offered, to the scheduled radius of bend, cutting the tube at the apex of the bend, measuring the tube wall at the cross section of this apex section, and comparing the measured value with the calculated value of  $TF$ .

**S1.2.4 Length of U-Bend Tube Legs**—The length of the tube legs as measured from the point of tangency of the bend and the tube leg to the end of the tube leg shall not be less than that specified, but may exceed the specified values by the following amounts:

Specified Length ( $L$ ), ft (m)	Tolerance (all Plus), in. (mm)
Up to 20 (6.1), incl	$\frac{1}{8}$ (3.2)
Over 20 to 30 (6.1 to 9.1), incl	$\frac{5}{32}$ (4.0)
Over 30 to 60 (9.1 to 18.3), incl	$\frac{1}{4}$ (6.4)
Over 60 (18.3)	$\frac{3}{8}$ (10.0)

**S1.2.4.1** The difference in the length of the tube legs shall not be greater than  $\frac{1}{8}$  in. (3.2 mm).

**S1.2.5 Squareness of Ends**—The end of any tube may depart from square by not more than the following amounts:

Tube OD, in. (mm)	Tolerance, in. (mm)
Up to $\frac{5}{8}$ (15.9), incl	0.010 (0.25)
Over $\frac{5}{8}$ (15.9)	0.016 (0.41)

### S1.3 Hydrostatic Test

**S1.3.1** When specified by the purchaser, the hydrostatic test shall be performed after bending. The minimum holding time at pressure shall be 5 s.

**S1.3.1.1** When hydrostatic testing is performed after bending, such testing will not be required on straight length tubes prior to bending.

**S1.3.1.2** The required fiber stress for computing hydrostatic test pressure shall be 26 600 psi (183.3 MPa).

## S2. HIGH YIELD STRENGTH TUBES

The following supplementary requirements shall apply when high yield strength tubes are specified by the purchaser in the inquiry, contract, or purchase order.

### S2.1 Limitations of Supplementary Requirements for High Yield Strength Tubes

**S2.1.1** The requirements for higher yield strength tubes included in this supplement are limited to the alloys, tube outside diameter (OD), and wall thickness ranges listed in Table 6.

### S2.2 Higher Yield Strength

**S2.2.1** The 0.2 % yield strength shall be as listed in Table 6. All other mechanical properties shall be as listed in Table 3.

### S2.3 Degree of Cold Work

**S2.3.1** No additional cold working over and above that normally required for these alloys shall be used in order to meet the higher yield strength.

### S2.4 Annealing

**S2.4.1** Tubing is to be furnished in the annealed condition. In order to meet the higher yield strength requirement, it may be necessary to control the final annealing parameters so as to preclude large grain sizes.

### S2.5 Marking Requirements

**S2.5.1** In addition to the marking requirements of SB-163, the marking shall include the letters HYS signifying higher yield strength.

### S3. COILED OR UNSTRAIGHTENED TUBING

The following supplementary requirements shall apply when coiled or unstraightened tubing is specified by the purchaser in the inquiry, contract, or purchase order.

#### S3.1 Unstraightened Tubing

S3.1.1 When the purchaser specifies coiled or unstraightened tubing after final heat treatment, the tensile specimens may be machine straightened prior to testing.

S3.1.2 On the certification and wherever the grade designation for unstraightened tubing appears, it shall be identified with the suffix letter "U" (for example, UNS N06600-U).

### S4. U.S. GOVERNMENT

The following supplementary requirements shall apply only when specified by the purchaser in the inquiry, contract, or order for agencies of the U.S. Government.

#### S4.1 Referenced Documents

S4.1.1 The following documents of the issue in effect on date of material purchased form a part of this specification to the extent referenced herein: Fed. Std. No. 102, Fed. Std. No. 123, Fed. Std. No. 182, and MIL-STD-129.

#### S4.2 Quality Assurance

##### S4.2.1 *Responsibility for Inspection:*

S4.2.1.1 Unless otherwise specified in the contract or purchase order, the manufacturer is responsible for the performance of all inspection and test requirements specified. Except as otherwise specified in the contract or purchase order, the manufacturer may use his own or any other suitable facilities for the performance of the inspection and test requirements unless disapproved by the purchaser at the time the order is placed. The purchaser shall have the right to perform any of the inspections or tests set forth when such inspections and tests are deemed necessary to ensure that the material conforms to prescribed requirements.

#### S4.3 Identification Marking

S4.3.1 The material shall be properly marked for identification in accordance with Fed. Std. No. 182 except that the ASTM specification number and the alloy number shall be used.

#### S4.4 Preparation for Delivery

##### S4.4.1 *Preservation, Packaging, Packing:*

S4.4.1.1 *Military Agencies*—The material shall be separated by size, composition, grade or class and shall be preserved and packaged, level A or C, packed level A, B, or C as specified in the contract or purchase order.

S4.4.1.2 *Civil Agencies*—The requirements of Fed. Std. No. 102 shall be referenced for definitions of the various levels of packaging protection.

##### S4.4.2 *Marking:*

S4.4.2.1 *Military Agencies*—In addition to any special marking required by the contract or purchase order, marking for shipment shall be in accordance with MIL-STD-129.

S4.4.2.2 *Civil Agencies*—In addition to any special marking required by the contract or purchase order, marking for shipment shall be in accordance with Fed. Std. No. 123.

## APPENDIXES

(Nonmandatory Information)

## X1. CONDITION AND FINISHES NORMALLY SUPPLIED

**X1.1 Scope**

X1.1.1 This appendix lists the conditions and finishes in which tube (other than converter sizes) are normally supplied. These are subject to change and the manufacturer should be consulted for the latest information available.

**X1.2 Nickel UNS N02200**

X1.2.1 *Annealed*—Soft, with a dull matte finish.

X1.2.2 *Stress Relieved*—Thermally treated below the annealing temperature to relieve the major portion of the internal stresses, with a thin, light to medium-dark surface.

X1.2.3 *Stress Relieved with Annealed Ends*—Same as X1.2.2 except with annealed ends.

**X1.3 Low-Carbon Nickel UNS N02201**

X1.3.1 *Annealed*—Similar to X1.2.1.

X1.3.2 *Stress Relieved*—Similar to X1.2.2.

X1.3.3 *Stress-Relieved With Annealed Ends*—Same as X1.3.2 except with annealed ends.

**X1.4 Nickel-Copper Alloy UNS N04400**

X1.4.1 *Annealed*—Soft with a dull matte finish.

X1.4.2 *Stress Relieved*—Thermally treated below the annealing temperature to relieve the major portion of the internal stresses resulting from cold drawing, with a thin, light to medium-dark surface.

X1.4.3 *Stress-Relieved With Annealed Ends*—Same as X1.4.2 except with annealed ends.

**X1.5 Nickel-Chromium-Aluminum Alloy UNS N06699, Nickel-Chromium-Iron Alloy UNS N06600, Nickel-Chromium-Iron Alloy UNS N06601, Nickel-Chromium-Iron Alloy UNS N06690, Nickel-Chromium-Iron Alloy UNS N06045, Nickel-Chromium-Iron Alloy UNS N06025, Nickel-Iron-Chromium Alloys (UNS N08120, UNS N08800, UNS N08810, UNS N08811, and UNS N08801), Nickel-Iron-Chromium-Molybdenum Alloy N08935, and Nickel-Iron-Chromium-Molybdenum-Copper Alloys UNS N08825 and UNS N06845**

X1.5.1 *Annealed and Ground Outside Diameter*—The inside diameter may have a bright finish when material is annealed in protective atmosphere; otherwise, the inside diameter is supplied descaled as necessary.

X1.5.2 *Annealed and Pickled (Not Ground)*—Outside and inside diameter will have dull, matte (pickled) surfaces.

## X2. CONVERTER SIZES

X2.1 Small diameter and light wall tube in outside diameters 1/4 in. (31.8 mm) and under all wall thicknesses may be furnished in the following conditions or tempers when so specified. The material is furnished in a limited range of sizes and the manufacturer should be consulted as to the various

outside diameters and wall thicknesses that may be furnished. Material shall be clean and scale-free. Such material shall conform to the applicable requirements indicated in Table X2.1 and Table X2.2.

TABLE X2.1 Mechanical Properties<sup>A</sup> of Small Diameter and Light Wall Tube

Material	Tensile Strength, ksi (MPa)	Yield Strength (0.2 % offset), <sup>B</sup> min, ksi (MPa)	Elongation in 2 in. or 50 mm, min, %	Rockwell Hardness <sup>C</sup> (Scale as Indicated)
<i>Nickel UNS N02200:</i>				
Annealed <sup>D</sup>	80 (552) max	15 (103)	33	B75, max
Half-hard <sup>E</sup>	80 (552) min	40 (276)	12	B75 to B90
Full hard <sup>F</sup>	95 (655) min	75 (517)	4	B90 to C30
<i>Low-carbon nickel UNS N02201:</i>				
Annealed <sup>D</sup>	70 (483) max	12 (83)	35	B62, max
Half-hard <sup>E</sup>	70 (483) min	30 (207)	12	B70 to B85
Full hard <sup>F</sup>	85 (586) min	65 (448)	4	B80 to B95
<i>Nickel-copper alloy UNS N04400:</i>				
Annealed <sup>D</sup>	90 (621) max	28 (193)	32	B80, max
Half-hard <sup>E</sup>	85 (586) min	55 (379)	12	B75 to B97
Full hard <sup>F</sup>	110 (758) min	90 (621)	3	B95 to C27
<i>Nickel-chromium-iron alloy UNS N06600:</i>				
Annealed <sup>D,G</sup>	80 (552) to 110 (758)	35 (241)	30	B92, max
Half-hard <sup>E</sup>	105 (724) min	55 (379)	13	B90 to B98
Full-hard <sup>F</sup>	130 (896) min	105 (724)	4	C19 to C34
<i>UNS N06601:</i>				
Annealed <sup>D,G</sup>	80 (552) to 110 (758)	30 (207)	30	B92 max
Half-hard <sup>E</sup>	105 (724) min	55 (379)	13	B90 to B98
Full-hard <sup>F</sup>	130 (896) min	105 (724)	4	C19 to C34
<i>UNS N06690:</i>				
Annealed <sup>D,G</sup>	85 (586) to 115 (793)	35 (241)	30	B92 max
Half-hard <sup>E</sup>	105 (724) min	55 (379)	13	B90 to B98
Full-hard <sup>F</sup>	130 (896) min	105 (724)	4	C19 to C34
<i>Nickel-iron chromium alloy UNS N08800:</i>				
Annealed <sup>D,G</sup>	75 (517) to 100 (689)	30 (207)	30	B95, max
Half-hard <sup>E</sup>	105 (724)	60 (414)	13	B93 to C26
Full hard <sup>F</sup>	130 (896)	105 (724)	4	C24 to C38
<i>Nickel-iron chromium- molybdenum-copper alloy UNS N08825:</i>				
Annealed <sup>D,G</sup>	85 (586) to 115 (793)	35 (241)	30	B90 max
Half-hard <sup>E</sup>	105 (724) min	75 (517)	15	B90 to C25
Full-hard <sup>F</sup>	125 (862) min	100 (689)	5	C25 to C35

<sup>A</sup> Not applicable to outside diameters under 1/8 in. (3.2 mm) and to wall thicknesses under 0.015 in. (0.38 mm).

<sup>B</sup> See 12.3.

<sup>C</sup> Hardness values, indicative of tensile strength, are shown for information only. All tests are subject to confirmation by tension tests. For hardness conversions, see Hardness Conversion Tables E140.

<sup>D</sup> This condition is sometimes designated as "No. 1 Temper."

<sup>E</sup> This condition is sometimes designated as "No. 2 Temper."

<sup>F</sup> This condition is sometimes designated as "No. 3 Temper."

<sup>G</sup> The minimum tensile strength value applies only to tubing in straight lengths.

**TABLE X2.2 Permissible Variations for Small Diameter and Light Wall Tube (Converter Sizes)**

NOTE 1—Ovality, Normal Wall Tube:

As-Drawn (No. 2 and 3) Tempers—Ovality will be held within the outside diameter tolerances shown in the table.

Annealed (No. 1) Temper—Ovality will be held within 2 % of the theoretical average outside diameter.

NOTE 2—Ovality Light Wall Tube:

As-Drawn (No. 2 and 3) Tempers—Ovality will be held within 2 % of the theoretical average outside diameter.

Annealed (No. 1) Temper—Ovality will be held within 3 % of the theoretical average outside diameter.

NOTE 3—Wall Tolerances, Light Wall Tube—The plus and minus wall tolerance shown in the table shall apply down to and including 0.005 in. (0.13 mm) in wall thickness. For wall thicknesses less than 0.005 in. the tolerance shall be plus and minus 0.0005 in.

NOTE 4—Random Lengths:

(a) Where nominal random lengths on tubing 1/8 in. and larger in outside diameter are specified, a length tolerance of plus and minus 3 1/2 ft (1.1 m) applies to the nominal length. This is a total spread of 7 ft. (2.1 m).

(b) Random lengths in sizes 1/8 in. (3.2 mm) and larger in outside diameter shall be subject to a length range from 5 to 24 ft (1.5 to 7.3 m). Long random lengths are subject to a range from 15 to 22 ft (4.6 to 6.7 m).

(c) Random lengths in sizes up to, but not including, 1/8 in. in outside diameter, and fragile light wall tubes over this outside diameter are subject to the length range from 1 to 15 ft (0.3 to 4.6 m).

NOTE 5—Cut Lengths—Tolerances on cut lengths shall be as follows:

NOTE 6—Straightness—Round tubing is subject to a straightness tolerance of one part in 600 (equivalent to a depth of arc of 0.030 in. (0.76 mm) in any 3 ft (0.9 m) of length).

NOTE 7—Eccentricity—Eccentricity (as defined in Table 4, Note 2) shall be limited to plus or minus 10 % of the specified wall or calculated average wall.

NOTE 8—When specified, the tolerance spread may be applied as desired. However, when not specified the tolerances shown below will apply. It should be noted that inside diameter tolerances are based upon the outside diameter range.

Length, ft	Tube Size, in.	Permissible Variations, in.				
		Over	Under			
U.S. Customary Units						
Under 1	Up to 1.250, incl	1/32	0			
1 to 4, incl	Up to 1.250, incl	1/16	0			
Over 4 to 10, incl	Up to 1.250, incl	3/32	0			
Over 10	Up to 1.250, incl	3/16	0			
Metric Units						
Length, m	Tube Size, mm	Permissible Variations, mm				
		Over	Under			
Under 0.3	Up to 31.75, incl	0.794	0			
0.3 to 1.2, incl	Up to 31.75, incl	1.59	0			
1.2 to 3.0, incl	Up to 31.75, incl	2.38	0			
Over 3.0	Up to 31.75, incl	4.76	0			
Specified Outside Diameter, in.	Outside Diameter, in.		Inside Diameter, in.		Wall Thickness, %	
	+	-	+	-	+	-
U.S. Customary Units						
Under 3/32	0.002	0	0	0.002	10	10
to 3/16 (0.1875), excl	0.003	0	0	0.003	10	10
3/16 to 1/2 (0.500), excl	0.004	0	0	0.004	10	10
1/2 to 1 1/4 (1.250), incl	0.005	0	0	0.005	10	10
Millimetres						
Under 2.38	0.051	0	0	0.051	10	10
2.38 to 4.76, excl	0.076	0	0	0.076	10	10
4.76 to 12.70, excl	0.102	0	0	0.102	10	10
12.70 to 31.8, incl	0.127	0	0	0.127	10	10

## SPECIFICATION FOR NICKEL-COPPER ALLOY ROD, BAR, AND WIRE



**SB-164**

(Identical with ASTM Specification B164-03(2014) except that certification and reporting have been made mandatory and lot definition is revised.)

# SPECIFICATION FOR NICKEL-COPPER ALLOY ROD, BAR, AND WIRE



SB-164

[Identical with ASTM Specification B 164-03(2014) except that certification and reporting have been made mandatory and lot definition is revised.]

## 1. Scope

**1.1** This specification covers nickel-copper alloys UNS N04400 and N04405 in the form of hot-worked and cold-worked rod and bar in the conditions shown in Table 1 and cold-worked wire in the conditions shown in Table 2.

**1.2** The values stated in inch-pound units are to be regarded as the standard. The values given in parentheses are for information only.

**1.3** *This standard does not purport to address all of the safety concerns, if any, associated with its use. It is the responsibility of the user of this standard to become familiar with all hazards including those identified in the appropriate Material Safety Data Sheet for this product/material as provided by the manufacturer, to establish appropriate safety and health practices, and determine the applicability of regulatory limitations prior to use.*

## 2. Referenced Documents

### 2.1 ASTM Standards:

- B 127 Specification for Nickel-Copper Alloy (UNS N04400) Plate, Sheet, and Strip
- B 880 Specification for General Requirements for Chemical Check Analysis Limits for Nickel, Nickel Alloys, and Cobalt Alloys
- E 8 Test Methods for Tension Testing of Metallic Materials
- E 18 Test Methods for Rockwell Hardness and Rockwell Superficial Hardness of Metallic Materials
- E 29 Practice for Using Significant Digits in Test Data to Determine Conformance with Specifications
- E 76 Test Methods for Chemical Analysis of Nickel-Copper Alloys
- E 140 Hardness Conversion Tables for Metals
- E 1473 Test Methods for Chemical Analysis of Nickel, Cobalt, and High-Temperature Alloys

### 2.2 Military Standards:

- MIL-STD-129 Marking for Shipment and Storage
- MIL-STD-271 Nondestructive Testing Requirements for Metals

## 3. Terminology

### 3.1 Definitions of Terms Specific to This Standard:

- 3.1.1 bar** — material of rectangular (flats), hexagonal, or square solid section up to and including 10 in. (254 mm) in width and  $\frac{1}{8}$  in. (3.2 mm) and over in thickness in straight lengths.
- 3.1.2 rod** — material of round solid section furnished in straight lengths.
- 3.1.3 wire** — a cold-worked solid product of uniform round cross section along its whole length, supplied in coiled form.

NOTE 1 — Hot-worked rectangular bar in widths 10 in. and under may be furnished as hot-rolled plate with sheared or cut edges in accordance with Specification B 127, provided the mechanical property requirements of Specification B 164 are met.

## 4. Ordering Information

**4.1** It is the responsibility of the purchaser to specify all requirements that are necessary for material ordered under this specification. Examples of such requirements include, but are not limited to, the following:

- 4.1.1** ASTM designation and year of issue.
- 4.1.2** UNS number.
- 4.1.3 Section** — Rod (round) or bar (square, hexagonal, or rectangular) or wire (round).
- 4.1.4 Dimensions** — Dimensions including length.

TABLE 1  
MECHANICAL PROPERTIES OF ROD AND BAR

Condition and Diameter or Distance Between Parallel Surfaces, in. (mm)	Tensile Strength min, psi (MPa)	Yield Strength (0.2% offset) <sup>A</sup> min., psi (MPa)	Elongation in 2 in. or 50 mm (or 4D), min, %	Rockwell Hardness (or equivalent)
UNS N04400				
<i>Cold-worked (as worked):</i>				
Rounds under 1/2 (12.7)	110 000 (760)	85 000 (585)	8 <sup>B</sup>	...
Squares, hexagons, and rectangles under 1/2 (12.7)	85 000 (585)	55 000 (380)	10 <sup>B</sup>	...
<i>Cold-worked (stress-relieved):</i>				
Rounds under 1/2 (12.7)	84 000 (580)	50 000 (345)	10 <sup>B</sup>	...
Rounds, 1/2 to 3 1/2 (12.7 to 88.9), incl	87 000 (600)	60 000 (415)	20	...
Rounds, over 3 1/2 to 4 (88.9 to 101.6), incl	84 000 (580)	55 000 (380)	20	...
Squares, hexagons and rectangles, 2 (50.8) and under	84 000 (580)	50 000 (345)	20 <sup>B,C</sup>	...
Squares, hexagons and rectangles, over 2 (50.8) to 3 1/8 (79.4), incl	80 000 (552)	50 000 (345)	20	...
<i>Hot-worked (as worked or stress-relieved):</i>				
Rounds, squares, and rectangles up to 12 (305), incl, and hexagons 2 1/8 (54) and under	80 000 (552)	40 000 (276)	30 <sup>D</sup>	...
Rounds, squares, and rectangles over 12 (305) to 14 (356), incl	75 000 (517)	40 000 (276)	30	...
Hexagons over 2 1/8 (54) to 4 (102), incl	75 000 (517)	30 000 (207)	25	...
Rings and disks	...	...	...	B 75 to B 95
<i>Hot-worked (annealed) or cold-worked (annealed):</i>				
Rod and bar, all sizes	70 000 (480)	25 000 (170)	35	...
Rings and disks	...	...	...	B 60 to B 75
<i>Forging quality:<sup>E</sup></i>				
All sizes	...	...	...	...
UNS N04405				
<i>Cold-worked (as worked or stress-relieved):</i>				
Rounds, under 1/2 (12.7)	85 000 (585)	50 000 (345)	8 <sup>B</sup>	...
Rounds, 1/2 (12.7) to 3 (76.2), incl	85 000 (585)	50 000 (345)	15	...
Rounds, over 3 (76.2) to 4 (101.6), incl	80 000 (552)	50 000 (345)	15	...
Hexagons and squares 2 (50.8) and under	85 000 (585)	50 000 (345)	15 <sup>B,C</sup>	...
Hexagons and squares over 2 (50.8) to 3 1/8 (79.4), incl	80 000 (552)	45 000 (310)	15	...
<i>Hot-worked (as hot-worked or stress-relieved):</i>				
Rounds 3 (76.2) and less	75 000 (517)	35 000 (241)	30	...
Hexagons and squares, 2 1/8 (54) and less	75 000 (517)	35 000 (241)	30	...
Hexagons and squares, over 2 1/8 (54) to 4 (101.6), incl	70 000 (480)	30 000 (207)	25	...
<i>Hot-worked (annealed) or cold-worked (annealed):</i>				
Rod and Bar, All sizes	70 000 (480)	25 000 (170)	35	...

<sup>A</sup> See 12.2.

<sup>B</sup> Not applicable to diameters or cross sections under 3/32 in. (2.4 mm).

<sup>C</sup> For sections under 1/2 in. (12.7 mm), the elongation shall be 10% min.

<sup>D</sup> For hot-worked flats 5/16 in. (7.9 mm) and under in thickness the elongation shall be 20% min.

<sup>E</sup> Forging quality is furnished to chemical requirements and surface inspection only. No tensile properties are required.

TABLE 2  
MECHANICAL PROPERTIES OF COLD-WORKED WIRE IN COIL<sup>4</sup>

Alloy Condition and Size, in. (mm)	Tensile Strength, psi (MPa)		Wrapping Test
	Min	Max	
UNS N04400 and N04405:			
Annealed, all sizes	70 000 (483)	85 000 (586)	All wire shall wrap around a rod of the same diameter as the wire without cracking
No. 0 temper, under 1/2 (12.7)	80 000 (552)	95 000 (655)	
No. 1 temper, under 1/2 (12.7)	90 000 (621)	110 000 (758)	
UNS N04400			
Regular temper, under 1/2 (12.7)	110 000 (758)	140 000 (965)	All wire up to 0.2294 in. (5.84 mm) inclusive, shall wrap around a rod of the same diameter as the wire without cracking. Wire over 0.2294 in. (5.84 mm) diameter shall wrap around a rod of twice the wire diameter without cracking.
Regular temper, 1/2 (12.7) and over	90 000 (621)	130 000 (896)	
Spring temper			
0.028 (0.71) and less	165 000 (1138)	...	
Over 0.028 (0.71) to 0.057 (1.45), incl	160 000 (1103)	...	
Over 0.057 (1.45) to 0.114 (2.90), incl	150 000 (1034)	...	
Over 0.114 (2.90) to 0.312 (7.92), incl	140 000 (965)	...	
Over 0.312 (7.92) to 0.375 (9.53), incl	135 000 (931)	...	
Over 0.375 (9.53) to 0.500 (12.7), incl	130 000 (896)	...	
Over 0.500 (12.7) to 0.563 (14.3), incl	120 000 (827)	...	

<sup>4</sup> Properties are not applicable to wire after straightening and cutting.

TABLE 3  
CHEMICAL REQUIREMENTS

Element	Composition Limits, %	
	UNS N04400	UNS N04405
Nickel <sup>4</sup>	63.0 min	63.0 min
Copper	28.0 min	28.0 min
	34.0 max	34.0 max
Iron	2.5 max	2.5 max
Manganese	2.0 max	2.0 max
Carbon	0.3 max	0.3 max
Silicon	0.5 max	0.5 max
Sulfur	0.024 max	0.025 min
		0.060 max

<sup>4</sup> Element shall be determined arithmetically by difference.

**4.1.5 Condition.**

**4.1.6 Finish.**

**4.1.7 Quantity** — feet or number of pieces.

**4.1.8 Certification** — Certification and reporting per para. 15 are mandatory.

**4.1.9 Samples for Product (Check) Analysis** — State whether samples for product (check) analysis should be furnished.

**4.1.10 Purchaser Inspection** — If purchaser wishes to witness tests or inspection of material at place of manufacture, the purchase order must so state indicating which test or inspections are to be witnessed.

**5. Chemical Composition**

**5.1** The material shall conform to the composition limits specified in Table 3.

**5.2** If a product (check) analysis is performed by the purchaser, the material shall conform to the product (check) analysis variations in Specification B 880.

**6. Mechanical Properties**

**6.1 Mechanical Properties** — The material shall conform to the mechanical properties specified in Table 1 for rod or bar, or in Table 2 for wire.

**7. Dimensions and Permissible Variations**

**7.1 Diameter, Thickness, or Width** — The permissible variations from the specified dimensions as measured on the diameter or between parallel surfaces of cold-worked rod and bar shall be as prescribed in Table 4, and of hot-worked rod and bar as prescribed in Table 5. The permissible variations in diameter of cold-worked wire shall be as prescribed in Table 6.

**7.2 Out-of-Round** — Hot-worked rods and cold-worked rods (except “forging quality”) all sizes, in straight lengths, shall not be out-of-round by more than one half the total permissible variations in diameter shown in Table 4 and Table 5, except for hot-worked rods 1/2 in. (12.7 mm) in diameter and under, which may be out-of-round by the total permissible variations in diameter shown in Table 5. Wire shall not be out-of-round by more than one-half the total permissible variations shown in Table 6.

**7.3 Corners** — Cold-worked bars will have practically exact angles and sharp corners.

**7.4 Machining Allowances for Hot-Worked Materials** — When the surfaces of hot-worked products are to be machined, the allowances prescribed in Table 7 are

TABLE 4  
PERMISSIBLE VARIATIONS IN DIAMETER OR DISTANCE BETWEEN PARALLEL SURFACES OF COLD-WORKED  
ROD AND BAR

Specified Dimension, in. (mm) <sup>4</sup>	Permissible Variations from Specified Dimension, in. (mm)	
	+	-
Rounds:		
$\frac{1}{16}$ (1.6) to $\frac{3}{16}$ (4.8), excl	0	0.002 (0.05)
$\frac{3}{16}$ (4.8) to $\frac{1}{2}$ (12.7), excl	0	0.003 (0.08)
$\frac{1}{2}$ (12.7) to $1\frac{5}{16}$ (23.8), incl	0.001 (0.03)	0.002 (0.05)
over $1\frac{5}{16}$ (23.8) to $1\frac{15}{16}$ (49.2), incl	0.0015 (0.04)	0.003 (0.08)
over $1\frac{15}{16}$ (49.2) to $2\frac{1}{2}$ (63.5), incl	0.002 (0.05)	0.004 (0.10)
over $2\frac{1}{2}$ (63.5) to 3 (76.2), incl	0.0025 (0.06)	0.005 (0.13)
over 3 (76.2) to $3\frac{1}{2}$ (88.9), incl	0.003 (0.08)	0.006 (0.15)
over $3\frac{1}{2}$ (88.9) to 4 (101.6), incl	0.0035 (0.09)	0.007 (0.18)
Hexagons, squares, rectangles:		
$\frac{1}{2}$ (12.7) and less	0	0.004 (0.10)
over $\frac{1}{2}$ (12.7) to $\frac{7}{8}$ (22.2), incl	0	0.005 (0.13)
over $\frac{7}{8}$ (22.2) to $1\frac{1}{4}$ (31.8), incl	0	0.007 (0.18)
over $1\frac{1}{4}$ (31.8) to $2\frac{1}{4}$ (57.2), incl	0	0.009 (0.23)
over $2\frac{1}{4}$ (57.2) to 3 (76.2), incl	0	0.011 (0.28)
over 3 (76.2) to $3\frac{1}{2}$ (88.9), incl	0	0.015 (0.38)
over $3\frac{1}{2}$ (88.9) to 4 (101.6), incl	0	0.017 (0.43)

<sup>4</sup> Dimensions apply to diameter of rounds, to distance between parallel surfaces of hexagons and squares, and separately to width and thickness of rectangles.

TABLE 5  
PERMISSIBLE VARIATIONS IN DIAMETER OR DISTANCE BETWEEN PARALLEL SURFACES OF  
HOT-WORKED ROD AND BAR

Specified Dimension, in. (mm) <sup>4</sup>	Permissible Variations from Specified Dimensions, in. (mm)	
	+	-
Rod and bar, hot-worked:		
1 (25.4) and under	0.016 (0.41)	0.016 (0.41)
over 1 (25.4) to 2 (50.8), incl	0.031 (0.79)	0.016 (0.41)
over 2 (50.8) to 4 (101.6), incl	0.047 (1.19)	0.031 (0.79)
over 4 (101.6)	0.125 (3.18)	0.063 (1.60)
Rod, rough-turned or ground:		
under 1 (25.4)	0.005 (0.13)	0.005 (0.13)
1 (25.4) and over	0.031 (0.79)	0
Forging quality rod: <sup>B</sup>		
Under 1 (25.4)	0.005 (0.13)	0.005 (0.13)
1 (25.4) and over	0.031 (0.79)	0

<sup>4</sup> Dimensions apply to diameter of rods, to distance between parallel surfaces of hexagons and squares, and separately to width and thickness of rectangles.

<sup>B</sup> Spot grinding is permitted to remove minor surface imperfections. The depth of these spot ground areas shall not exceed 3% of the diameter of the rod.

TABLE 6  
PERMISSIBLE VARIATIONS IN DIAMETER OF COLD-WORKED WIRE

Diameter, in. (mm)	Permissible Variations, in. (mm), ±
Under 0.0044 (0.11)	0.0002 (0.005)
0.0044 (0.11) to 0.0079 (0.20), incl	0.00025 (0.006)
Over 0.0079 (0.20) to 0.0149 (0.38), incl	0.0003 (0.008)
Over 0.0149 (0.38) to 0.0199 (0.51), incl	0.0004 (0.010)
Over 0.0199 (0.51) to 0.031 (0.79), incl	0.0005 (0.013)
Over 0.031 (0.79) to 0.045 (1.14), incl	0.0006 (0.015)
Over 0.045 (1.14) to 0.079 (2.01), incl	0.0007 (0.018)
Over 0.079 (2.01) to 0.1875 (4.76), incl	0.001 (0.025)
Over 0.1875 (4.76) to 0.3125 (7.93), incl	0.002 (0.051)
Over 0.3125 (7.93)	0.003 (0.076)

TABLE 7  
NORMAL MACHINING ALLOWANCES FOR HOT-WORKED MATERIAL

Finished-Machined Dimensions for Finishes as Indicate Below in. (mm) <sup>A</sup>	Normal Machining Allowance, in. (mm)			
	On Diameter, for Rods	Distance Between Parallel Surfaces, for Hexagonal and Square Bar	For Rectangular Bar	
			On Thickness	On Width
Hot-worked: <sup>B</sup>				
Up to 7/8 (22.2), incl	1/8 (3.2)	1/8 (3.2)	1/8 (3.2)	3/16 (4.8)
Over 7/8 to 1 7/8 (22.2 to 47.6), incl	1/8 (3.2)	3/16 (4.8)	1/8 (3.2)	3/16 (4.8)
Over 1 7/8 to 2 7/8 (47.6 to 73.0), incl	3/16 (4.8)	1/4 (6.4)	...	3/16 (4.8)
Over 2 7/8 to 3 13/16 (73.0 to 96.8), incl	1/4 (6.4)	...	...	3/16 (4.8)
Over 3 13/16 (96.8)	1/4 (6.4)	...	...	3/8 (9.5)
Hot-worked rods:				
Rough-turned or rough-ground: <sup>C</sup>				
1 5/16 to 4 (23.8 to 101.6), incl, in diameter	1/16 (1.6)	...	...	...
Over 4 to 12 (101.6 to 304.8), incl, in diameter	7/8 (3.2)	...	...	...

<sup>A</sup> Dimensions apply to diameter of rods, to distance between parallel surfaces of hexagonal and square bar, and separately to width and thickness of rectangular bar.

<sup>B</sup> The allowances for hot-worked material in Table 5 are recommended for rods machined in lengths of 3 ft (0.91 m) or less and for bars machined in lengths of 2 ft (0.61 m) or less. Hot-worked material to be machined in longer lengths should be specified showing the finished cross-sectional dimension and the length in which the material will be machined in order that the manufacturer may supply material with sufficient oversize, including allowance for out-of-straightness.

<sup>C</sup> Applicable to 3 ft (0.91 m) max length.

recommended for normal machining operations.

**7.5 Length** — The permissible variations in length of cold-worked and hot-worked rod and bar shall be as prescribed in Table 8.

**7.5.1** Rods and bars ordered to random or nominal lengths will be furnished with either cropped or saw-cut ends; material ordered to cut lengths will be furnished with square saw-cut or machined ends.

**7.6 Straightness:**

**7.6.1** The permissible variations in straightness of cold-worked rod and bar as determined by the departure from straightness shall be as prescribed in Table 9.

**7.6.2** The permissible variations in straightness of precision straightened cold-worked rod as determined by

the departure from straightness shall be as prescribed in Table 10.

**7.6.2.1** In determining straightness in the standard 42-in. (1.07-m) distance between supports or, when specified, in determining straightness in lengths not in excess of those shown in Table 10, the rod shall be placed on a precision table equipped with ball-bearing rollers and a micrometer or dial indicator. The rod shall then be rotated slowly against the indicator, and the deviation from straightness in any portion of the rod between the supports shall not exceed the permissible variations prescribed in Table 10. The deviation from straightness (throw in one revolution) is defined as the difference between the maximum and minimum readings of the dial indicator in one complete revolution of the rod.

TABLE 8  
PERMISSIBLE VARIATIONS IN LENGTH OF RODS AND BAR

Random mill lengths:	
Hot-worked	6 to 24 ft (1.83 to 7.31 m) long with not more than 25 weight % between 6 and 9 ft (1.83 and 2.74 m) <sup>4</sup>
Cold-worked	6 to 20 ft (1.83 to 6.1 m) long with not more than 25 weight % between 6 and 10 ft (1.83 and 3.05 m).
Multiple lengths	Furnished in multiples of a specified unit length, within the length limits indicated above. For each multiple, an allowance of $\frac{1}{4}$ in. (6.4 mm) will be made for cutting, unless otherwise specified. At the manufacturer's option, individual specified unit lengths may be furnished.
Nominal lengths	Specified nominal lengths having a range of not less than 2 ft (610 mm) with no short lengths allowed <sup>B</sup>
Cut lengths	A specified length to which all rods and bars will be cut with a permissible variation of plus $\frac{1}{8}$ in. (3.2 mm), minus 0 for sizes 8 in. (203 mm) and less in diameter or distance between parallel surfaces. For larger sizes, the permissible variation shall be $+\frac{1}{4}$ in. (6.4 mm), -0.

<sup>4</sup> For hot-worked sections weighing over 25 lb/ft (37 kg/m) and for smooth forged products, all sections, short lengths down to 2 ft (610 mm) may be furnished.

<sup>B</sup> For cold-worked rods and bars under  $\frac{1}{2}$  in. (12.7 mm) in diameter or distance between parallel surfaces ordered to nominal or stock lengths with a 2-ft (610-mm) range, at least 93% of such material shall be within the range specified; the balance may be in shorter lengths but in no case shall lengths less than 4 ft (1220 mm) be furnished.

TABLE 9  
PERMISSIBLE VARIATIONS IN STRAIGHTNESS OF COLD-WORKED RODS AND BARS

Specified Diameter or Distance Between Parallel Surfaces, in. (mm) <sup>A</sup>	Permissible Variations in Lengths Indicated, in. (mm)
Rounds: ½ (12.7) to 4 (101.6), incl	Depth of Chord: 0.030 (0.76) per ft (305 mm) of length
Hexagons, Squares, Rectangles: ½ (12.7) to 4 (101.6), incl	0.030 (0.76) per ft (305 mm) of length

<sup>A</sup> Material under ½ in. (12.7 mm) shall be reasonably straight and free of sharp bends and kinks.

**7.6.3** The permissible variations in straightness of hot-worked rod and bar as determined by the departure from straightness shall be as specified in Table 11.

## 8. Workmanship, Finish, and Appearance

**8.1** The material shall be uniform in quality and condition, smooth, commercially straight or flat, and free of injurious imperfections.

## 9. Sampling

### 9.1 Lot—Definition:

**9.1.1** A lot for chemical analysis shall consist of one heat.

**9.1.2** A lot for mechanical properties testing shall consist of all material from the same heat, nominal diameter or thickness, and condition.

#### 9.1.2.1 DELETED

### 9.2 Test Material Selection:

**9.2.1 Chemical Analysis** —Representative samples from each lot shall be taken during pouring or subsequent processing.

**9.2.1.1** Product (check) analysis shall be wholly the responsibility of the purchaser.

**9.2.2 Mechanical Properties** —Samples of the material to provide test specimens for mechanical properties shall be taken from such locations in each lot as to be representative of that lot.

## 10. Number of Tests

**10.1 Chemical Analysis** — One test per lot.

**10.2 Tension** — One test per lot.

**10.3 Hardness** — One test per lot.

**10.4 Wrapping** — One test per lot.

## 11. Specimen Preparation

**11.1** Tension test specimens shall be taken from material in the final condition and tested in the direction of fabrication.

**11.1.1** All rod, bar, and wire shall be tested in full cross-section size when possible. When a full cross-section size test cannot be performed, the largest possible round specimen shown in Test Methods E 8 shall be used. Longitudinal strip specimens shall be prepared in accordance with Test Methods E 8 for rectangular bar up to ½ in. (12.7 mm) inclusive, in thicknesses that are too wide to be pulled full size.

**11.2** Hardness test specimens shall be taken from material in the final condition.

**11.3** In order that the hardness determinations may be in reasonably close agreement, the following procedure is suggested:

**11.3.1** For rod and wire under ½ in. (12.7 mm) in diameter, hardness readings shall be taken on a flat surface prepared by filing or grinding approximately ¼ in. (1.6 mm) from the outside surface of the rod.

**11.3.2** For rod and wire ½ in. in diameter and larger, and for hexagonal, square, and rectangular bar, all sizes, hardness readings shall be taken on a cross section midway between the surface and center of the section.

## 12. Test Methods

**12.1** The chemical composition, mechanical, and other properties of the material as enumerated in this specification shall be determined, in case of disagreement, in accordance with the following methods:

Test	ASTM Designation
Chemical Analysis	E 76, E 1473
Tension	E 8
Rockwell Hardness	E 18
Hardness Conversion	E 140
Rounding Procedure	E 29

ASMENORMDOC.COM : Click to view the full PDF of ASME BPVC.II.B (ASME BPVC Section II part B) 2025

**TABLE 10**  
**PERMISSIBLE VARIATIONS IN STRAIGHTNESS OF PRECISION-STRAIGHTENED COLD-WORKED SHAFTING UNS N04400 ONLY**

Specified Diameter of Shafting, in.	Standard Distance Between Supports	Permissible Variations (Throw in One Revolution) from Straightness, in.
$\frac{1}{2}$ to $\frac{15}{16}$ , incl	42 in.	0.005
Over $\frac{15}{16}$ to $1\frac{15}{16}$ , incl	42 in.	0.006
Over $1\frac{15}{16}$ to $2\frac{1}{2}$ , incl	42 in.	0.007
Over $2\frac{1}{2}$ to 4, incl	42 in.	0.008
$\frac{3}{4}$ to $\frac{15}{16}$ , incl	Specified lengths of 3 to 10 ft.	0.004 plus 0.0025 for each foot or fraction thereof in excess of 3 ft
Over $\frac{15}{16}$ to 4, incl	Specified lengths of 20 ft and less	0.005 plus 0.0015 for each foot or fraction thereof in excess of 3 ft

Specified Diameter of Shafting, mm	Standard Distance Between Supports	Permissible Variations (Throw in One Revolution) from Straightness, mm
12.7 to 23.8, incl	1067 mm	0.13
Over 23.8 to 49.2, incl	1067 mm	0.15
Over 49.2 to 63.5, incl	1067 mm	0.18
Over 63.5 to 101.6, incl	1067 mm	0.20
19.1 to 23.8, incl	specified lengths of 914 to 3050 mm	10.2 plus 0.2 for each metre or fraction thereof in excess of 914 mm
Over 23.8 to 101.6, incl	specified lengths of 6100 mm and less	12.7 plus 0.13 for each metre or fraction thereof in excess of 914 mm

**12.2** For purposes of determining compliance with the specified limits for requirements of the properties listed in the following table, an observed value or a calculated value shall be rounded as indicated below, in accordance with the rounding method of Practice E 29:

Test	Rounded Unit for Observed or Calculated Value
Chemical composition, hardness, and tolerances (when expressed in decimals)	Nearest unit in the last right-hand place of figures of the specified limit. If two choices are possible, as when the digits dropped are exactly a 5, or a 5 followed only by zeros, choose the one ending in an even digit, with zero defined as an even digit.
Tensile strength and yield strength	Nearest 1000 psi (6.9 MPa)
Elongation	Nearest 1%

**13. Inspection**

**13.1** Inspection of the material shall be made as agreed upon between the manufacturer and the purchaser as part of the purchase contract.

**14. Rejection and Rehearing**

**14.1** Material, tested by the purchaser, that fails to conform to the requirements of this specification may be rejected. Rejection should be reported to the producer or supplier promptly and in writing. In case of dissatisfaction with the results of the test, the producer or supplier may make claim for a rehearing.

**15. Certification**

**15.1** A producer's or supplier's certification shall be furnished to the purchaser that the material was manufactured, sampled, tested, and inspected in accordance with

**TABLE 11**  
**PERMISSIBLE VARIATIONS IN STRAIGHTNESS OF**  
**HOT-WORKED RODS AND BARS<sup>A</sup>**

Finish	Permissible Variations, in./ft (mm/m) <sup>B</sup>
Rods and bars, hot-worked	0.050 (4.2) <sup>C</sup>
Round—hot worked, rough-ground, or rough-turned	0.050 (4.2) <sup>C</sup>

<sup>A</sup> Not applicable to forging quality.

<sup>B</sup> Material under 1/2 in. (12.7 mm) shall be reasonably straight and free of sharp bends and kinks.

<sup>C</sup> The maximum curvature (depth of chord) shall not exceed the values indicated multiplied by the length in feet.

this specification and has been found to meet the requirements. A report of the test results shall be furnished.

**16. Product Marking**

**16.1** The following information shall be marked on the material or included on the package, or on a label or tag attached thereto: The name of the material or UNS Number, heat number, condition (temper), ASTM B 164, the size, gross, tare, and net weight, consignor and consignee address, contract or order number, or such other information as may be defined in the contract or order.

**17. Keywords**

**17.1** bar; rod; wire; N04400

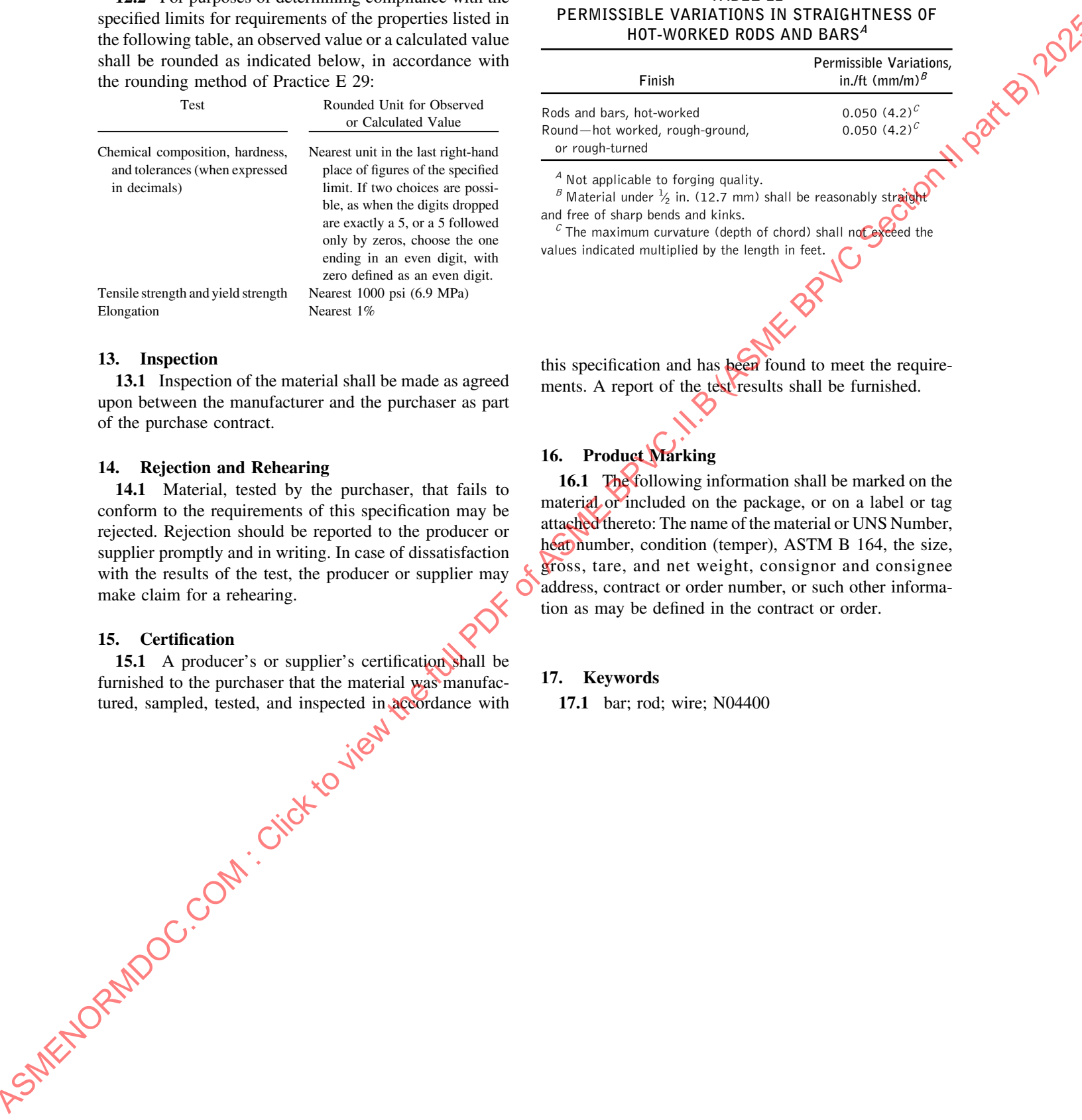

**SUPPLEMENTARY REQUIREMENTS**

The following supplementary requirements shall apply only when specified by the purchaser in the inquiry, contract, or order, for agencies of the U. S. Government.

**S1. Scope**

**S1.1** The requirements for annealed, hot finished, and cold rolled and stress relieved rod and bar shall apply for shapes in the same conditions except as modified herein for chemistry and ultrasonic inspection.

**S2. Referenced Documents**

**S2.1** The following documents of the issue in effect on date of material purchased form a part of this specification to the extent referenced herein:

**S2.1.1 Federal Standards:**

Fed. Std. No. 102 Preservation, Packaging and Packing Levels

Fed. Std. No. 123 Marking for Shipment (Civil Agencies)

Fed. Std. No. 182 Continuous Identification Marking of Nickel and Nickel-Base Alloys

**S2.1.2 Military Standard:**

MIL-STD-129 Marking for Shipment and Storage

**S3. Chemical Composition**

**S3.1** The material shall conform to the composition limits specified in Table 3 except as specified in Table S3.1 or Table S3.2.

**S4. Mechanical Properties**

**S4.1** UNS N04400 cold worked bar and rod shall be supplied in the stress relieved condition.

**S5. Number of Tests**

**S5.1** For wire, the number of samples for tension and wrapping tests shall be as specified in Table S5.1.

**TABLE S3.1  
CHEMICAL REQUIREMENTS**

Element	Composition Limits, %
	UNS N04400
Carbon	0.2 max.
Sulfur	0.015 max.
Aluminum	0.5 max.
Lead	0.006 max.
Tin	0.006 max.
Zinc	0.02 max.
Phosphorus	0.02 max.

**S6. Specimen Preparation**

**S6.1** Tensile specimens for rod and bar up to 1½ in. in diameter or minimum thickness shall coincide with the central axis of the piece. Tensile specimens for rod and bar 1½ in. and over in diameter or thickness shall be located midway between the center and the rolled or drawn surface of the piece.

**S6.2** Tensile specimens for wire shall be of the full cross section and not less than 15 in. in length. Specimens shall be free from sharp bends or kinks. The distance between the jaws of the testing machine, with the specimen in place ready for testing, shall be not less than 10 in.

**S7. Nondestructive Tests**

**S7.1** When specified by the purchaser, each piece of each lot shall be inspected. The purchaser shall specify if one or both tests are required.

**TABLE S3.2  
CHEMICAL REQUIREMENTS**

Element	Composition Limits, %
	UNS N04405
Aluminum	0.5 max.
Lead	0.006 max.
Tin	0.006 max.
Zinc	0.02 max.
Phosphorus	0.02 max.

**TABLE S5.1  
REQUIRED SAMPLES FOR TENSION AND WRAPPING TESTS OF WIRE**

Lot Size, lbs	Number of Samples for Each Test
¼ in. diameter and less:	
180 and under	1
181 to 500	2
501 to 800	3
801 to 1300	5
1301 to 3200	7
3201 to 5000	10
Over ¼ in. diameter:	
For each 500 lbs. or fraction thereof	1

TABLE S7.1  
ULTRASONIC TESTING REFERENCE HOLE FOR ROD  
AND BAR

Material Thickness, in. (mm)	Hole Diameter, in. (mm)
Up to and including 6 (152)	$\frac{1}{8}$ (3.18)
Over 6 (152) and including 16 (406)	$\frac{1}{4}$ (6.4)
Over 16 (406)	As agreed upon

## S7.2 Ultrasonic Tests:

### S7.2.1 General Requirements:

**S7.2.1.1** Ultrasonic testing shall be performed in accordance with MIL-STD-271 as modified by the requirements specified herein. Testing shall be done by a longitudinal wave or shear wave technique as specified herein.

**S7.2.1.2** Acoustic compatibility between the production material and the calibration standard material shall be within 75%. If the acoustic compatibility is within 25%, no gain compensation is required for the examination. If acoustic compatibility difference is between 25% and 75%, a change in the gain or dB controls shall be accomplished to compensate for the differences in acoustic compatibility. This method cannot be used if the ultrasonic noise level exceeds 50% of the rejection value.

### S7.2.2 Calibration:

**S7.2.2.1 Shear Wave** — The shear wave test shall be calibrated on two notches, one notch cut into the inside and one into the outside surface. The notches shall be cut axially and shall have a depth of 5% of the material thickness or  $\frac{1}{4}$  in. (6.4 mm), whichever is less. Notch length shall not exceed 1 in. (25.4 mm). Notches shall be made either in the piece to be examined or in a separate defect-free specimen of the same size (within  $\pm \frac{1}{8}$  in. (3.18 mm)), shape, material, and condition, or acoustically similar material. The position and amplitude of the response from each notch shall be marked on the instrument screen or a transparent overlay, and these marks shall be used as the evaluation reference. Indications that appear between these points shall be evaluated on the basis of a straight line joining the two peak amplitudes.

**S7.2.2.2 Longitudinal Wave** — The longitudinal wave test shall be calibrated on a flatbottomed reference hole of a given diameter in accordance with Table S7.1 for specified material thickness drilled either into the piece to be tested or into a separate defect-free specimen of the same size (within  $\pm \frac{1}{8}$  in. (3.18 mm)), shape, material, and condition, or acoustically similar material. Holes are to be drilled to midsection and the bottom of the hole shall be parallel to the entrant surface. The ultrasonic test instrument shall be adjusted so that the response from the reference hole shall not be less than 25% and not more than 75% of screen height.

**S7.2.2.3 Recalibration** — During quality conformance inspection, any realignment of the search unit that will cause a decrease in the calibrated sensitivity and resolution, or both, or any change in search unit, couplant, instrument settings, or scanning speed from that used for calibration shall require recalibration. Recalibration shall be performed at least once per 8 h shift.

**S7.2.3 Procedure** — S7.2.3.1 and S7.2.3.2 describe the requirements for rod and bar. Wire shall be excluded from these requirements. Shapes other than those listed below shall be tested to the extent set forth in the approved procedure.

**S7.2.3.1 Rod** — Rod shall be tested using the longitudinal wave technique. The scanning path shall be circumferential or helical with the beam directed along a radius of the rod.

**S7.2.3.2 Bar** — Bar shall be tested using the longitudinal wave technique through one side of each pair of parallel sides (thickness and width only).

### S7.2.4 Acceptance Criteria:

**S7.2.4.1 Shear Wave** — Any material that produces indications equal to or larger than the response from the reference notch or higher than the straight line joining the two peak amplitudes shall be rejected.

**S7.2.4.2 Longitudinal Wave** — Any material that produces indications equal to or larger than the response from the reference hole, or that produces a complete loss of back reflection shall be rejected. Material shall be tested using a square, rectangular, or circular transducer having an effective area of one square inch or less, but no dimension shall be smaller than the diameter of the reference hole. In the event of disagreement on the degree of back reflection loss, it shall be determined by the contact method using a 1 to  $1\frac{1}{8}$  in. (25.4 to 28.6 mm) diameter transducer or one whose area falls within this range.

**S7.2.4.3 Reference Notch Removal** — If reference notches or flatbottomed holes are made in the material to be tested, they shall be so located that their subsequent removal will not impair the suitability of the material for its intended use.

## S7.3 Liquid Penetrant Inspection:

**S7.3.1 Procedure** — Liquid penetrant inspection shall be in accordance with MIL-STD-271.

**S7.3.2 Surface Requirements** — The surface produced by hot working is not suitable for liquid penetrant testing. Therefore, liquid penetrant testing will not be applicable to products ordered with a hot finished surface.

**S7.3.3 Acceptance Criteria** — Linear defects revealed by liquid penetrant inspection shall be explored by grinding or other suitable means. Depth of defects shall not exceed the dimensional tolerance of the material.

**S8. Quality Assurance****S8.1 Responsibility for Inspection:**

**S8.1.1** Unless otherwise specified in the contract or purchase order, the manufacturer is responsible for the performance of all inspection and test requirements specified. Except as otherwise specified in the contract or purchase order, the manufacturer may use his own or any other suitable facilities for the performance of the inspection and test requirements unless disapproved by the purchaser at the time the order is placed. The purchaser shall have the right to perform any of the inspections or tests set forth when such inspections and tests are deemed necessary to ensure that the material conforms to prescribed requirements:

**S9. Identification Marking**

**S9.1** All material shall be properly marked for identification in accordance with Fed. Std. No. 182, except that the ASTM Specification number and the alloy number shall be used.

**S10. Preparation for Delivery****S10.1 Preservation, Packaging, Packing:**

**S10.1.1 Military Agencies** — The material shall be separated by size, composition, grade, or class and shall be preserved and packaged, level A or C, packed level A, B, or C as specified in the contract or purchase order.

**S10.1.2 Civil Agencies** — The requirements of Fed. Std. No. 102 shall be referenced for definitions of the various levels of packaging protection.

**S10.2 Marking:**

**S10.2.1 Military Agencies** — In addition to any special marking required by the contract or purchase order, marking for shipment shall be in accordance with MIL-STD-129.

**S10.2.2 Civil Agencies** — In addition to any special marking required by the contract or purchase order, marking for shipment shall be in accordance with Fed. Std. No. 123.

## APPENDIX

## (Nonmandatory Information)

**X1. CONDITIONS AND FINISHES NORMALLY SUPPLIED**

**X1.1** The various conditions and finishes in which rod and bar are procurable are as follows:

**X1.1.1** *Hot-Worked* — With a tightly adherent, black, mill oxide surface.

**X1.1.2** *Hot-Worked, Rough-Ground* — Similar to X1.1.1 except rough-ground.

**X1.1.3** *Hot-Worked, Rough-Turned* — Similar to X1.1.1 except rough turned with a broad nosed tool similar to a bar peeling operation and thus may not be straight. Intended generally for machining where an over-hauled surface is desired, essentially for machined step down shafts or parts machined in short lengths of 3 ft (910 mm) or less.

**X1.1.3.1** Where material is intended for shafting for diameters over 4 in. (101.6 mm) the “stress-relieved” temper is recommended.

**X1.1.4** *Hot-Worked, Forging Quality* — Rough turned and spot ground, as necessary, for sizes 1 in. in diameter and over; rough ground and spot ground for sizes under 1 in. (25.4 mm) in diameter. Material is selected from heats of known, good hot malleability.

NOTE X1.1— For sizes 4 in. in diameter and less, cold-worked rod may be used also for forging by virtue of the fact such rod has been overhauled for removal of mechanical surface defects prior to cold-working. In such cases, the user should run pilot forging tests to ensure himself that such material has the desired hot malleability range.

**X1.1.5** *Forging Quality, Bolt Tolerance* — Hot-worked, of known good hot malleability, but not overhauled prior to skin pass, cold-working to tolerances specified herein, which tolerances conform to the major diameter

tolerances of Class 3 fit of American Standard screw threads. No mechanical properties are offered since material is to be subsequently hot worked. Intended primarily for hot heated bolts but is of somewhat inferior quality, as to surface seams and cracks compared to forging quality, see X1.1.4.

**X1.1.6** *Hot-Worked, Annealed* — Soft with a tightly adherent oxide that may vary from dark to light.

**X1.1.7** *Hot-Worked, Annealed, and Pickled* — Same as X1.1.6 except descaled for removal of mill oxide. Provides for better surface inspection than does hot-worked material and often employed where welding is involved where removal of mill oxide is desired.

NOTE X1.2— Annealing prior to pickling may be required in order to reduce the mill oxide since uniform pickling of an unreduced oxide is difficult.

**X1.1.8** *Cold-Worked, Stress-Relieved* — Hot worked, overhauled, cold-worked, and straightened. Material is thermally treated to relieve the major portion of the internal stresses resulting from cold-working and may have a very thin light to medium oxide. Intended primarily for shafting and for machined parts where minimum “walking” or distortion after metal removal is desired.

**X1.1.9** *Cold-Worked, Annealed* — Hot-worked, overhauled, cold-worked, and straightened. Annealed for softness and with a dull matte finish.

NOTE X1.3— *UNS N04405 Material*—This is the machining grade and is preferred generally to UNS N04400 for intricately machined parts, particularly for parts that are to be machined on automatics or require drilling.

# SPECIFICATION FOR NICKEL-COPPER ALLOY SEAMLESS PIPE AND TUBE



**SB-165**

(Identical with ASTM Specification B165-19 except for deletion of 1.1.1.)

ASMENORMDOC.COM : Click to view the full PDF of ASME BPVC.II.B (ASME BPVC Section II part B) 2025

# Specification for Nickel-Copper Alloy Seamless Pipe and Tube

## 1. Scope

1.1 This specification covers nickel-copper alloy UNS N04400 in the form of cold-worked seamless pipe and tube in the conditions shown in Table 1 and Table X1.1.

### 1.1.1 DELETED

1.2 The values stated in inch-pound units are to be regarded as standard. The values given in parentheses are mathematical conversions to SI units that are provided for information only and are not considered standard.

1.3 *This standard does not purport to address all of the safety concerns, if any, associated with its use. It is the responsibility of the user of this standard to become familiar with all hazards including those identified in the appropriate Material Safety Data Sheet (MSDS) for this product/material as provided by the manufacturer, to establish appropriate safety, health, and environmental practices, and determine the applicability of regulatory limitations prior to use.*

1.4 *This international standard was developed in accordance with internationally recognized principles on standardization established in the Decision on Principles for the Development of International Standards, Guides and Recommendations issued by the World Trade Organization Technical Barriers to Trade (TBT) Committee.*

## 2. Referenced Documents

### 2.1 ASTM Standards:

- B829 Specification for General Requirements for Nickel and Nickel Alloys Seamless Pipe and Tube
- E8 Test Methods for Tension Testing of Metallic Materials [Metric] E0008\_E0008M
- E29 Practice for Using Significant Digits in Test Data to Determine Conformance with Specifications
- E76 Test Methods for Chemical Analysis of Nickel-Copper Alloys (Withdrawn 2003)

## 3. Terminology

### 3.1 Definitions of Terms Specific to This Standard:

3.1.1 *average diameter, n*—average of the maximum and minimum outside diameters, as determined at any one cross-section of the pipe or tube.

3.1.2 *pipe, n*—tube conforming to the particular dimensions commercially known as pipe sizes, see Table X2.1.

3.1.3 *seamless pipe or tube, n*—pipe or tube produced with a continuous periphery in all stages of the operations.

3.1.4 *tube, n*—hollow product of round or any other cross-section having a continuous periphery.

## 4. Ordering Information

4.1 Orders for material to this specification shall include information with respect to the following:

- 4.1.1 Alloy name or UNS number.
- 4.1.2 ASTM designation and year of issue.
- 4.1.3 *Condition* (see Appendix X3).
- 4.1.4 *Finish* (see Appendix X3).
- 4.1.5 *Dimensions*:
  - 4.1.5.1 *Tube*—Specify outside diameter and nominal or minimum wall.
  - 4.1.5.2 *Pipe*—Specify standard pipe size and schedule.
  - 4.1.5.3 *Length*—Cut to length or random.
- 4.1.6 *Quantity*—Feet or number of pieces.
- 4.1.7 *Hydrostatic Test or Nondestructive Electric Test*—Specify type of test (see 6.2).
- 4.1.8 *Hydrostatic Pressure Requirements*—Specify test pressure if other than required by 12.3.1.

TABLE 1 Mechanical Properties of Pipe and Tube

Condition and Size	Tensile Strength, min, psi (MPa)	Yield Strength, min. (0.2 % offset), min, psi (MPa)	Elongation in 2 in. or 50 mm (or 4 D), min, %
Annealed:			
5 in. (127 mm) outside diameter and under	70 000 (480)	28 000 (195)	35
Over 5 in. (127 mm) outside diameter	70 000 (480)	25 000 (170)	35
Stress-Relieved: All sizes	85 000 (585)	55 000 (380)	15

4.1.9 *Samples for Product (Check) Analysis*—State whether samples for product (check) analysis should be furnished (see 5.2).

4.1.10 *Purchaser Inspection*—If purchaser wishes to witness tests or inspection of material at place of manufacture, the purchase order must so state indicating which tests or inspections are to be witnessed (Section 13).

4.1.11 *Small-Diameter Tube and Tube with Specified Wall Thickness 3 % or Less of the Specified Outside Diameter (Converter Sizes)*—See Appendix X1.

## 5. Chemical Composition

5.1 The material shall conform to the composition limits specified in Table 2.

5.2 If a product (check) analysis is performed by the purchaser, the material shall conform to the product (check) analysis variations in Table 2.

## 6. Mechanical and Other Requirements

6.1 *Tension Test*—The material shall conform to the tensile properties specified in Table 1.

6.1.1 Tensile properties for material specified as small-diameter tube and tube with specified wall thickness 3 % or less of the specified outside diameter (converter sizes) shall be in accordance with Table X1.1.

6.2 *Hydrostatic or Nondestructive Electric Test*—Each pipe or tube shall be subjected to either the hydrostatic test or the nondestructive electric test. The type of test to be used shall be at the option of the manufacturer, unless otherwise specified in the purchase order.

TABLE 2 Chemical Requirements

Element	Composition Limits, %	Product (Check) Analysis Variations, under min or over max, of the Specified Limit of Element
Ni <sup>a</sup>	63.0 min	0.45
Cu	28.0 min 34.0 max	0.15 0.20
Fe	2.5 max	0.05
Mn	2.0 max	0.04
C	0.3 max	0.02
Si	0.5 max	0.03
S	0.024 max	0.005

<sup>a</sup> Element shall be determined arithmetically by difference.

## 7. Dimensions and Permissible Variations

7.1 *Diameter and Wall Thickness*—The permissible variations in the outside diameter and wall thickness shall conform to the permissible variations prescribed in Table 3.

7.2 *Length*—When material is ordered cut-to-length, the length shall conform to the permissible variations prescribed in Table 4.

7.3 *Straightness*—Material shall be reasonably straight and free of bends and kinks.

7.4 *Ends*—Ends shall be plain cut and deburred.

7.5 Permissible variations for material specified as small-diameter tube and tube with specified wall thickness 3 % or less of the specified outside diameter (converter size) shall conform to the permissible variations prescribed in Table X1.2.

## 8. Workmanship, Finish, and Appearance

8.1 The material shall be uniform in quality and temper, smooth, commercially straight, and free of injurious imperfections.

## 9. Sampling

9.1 *Lot Definition:*

9.1.1 A lot for chemical analysis shall consist of one heat.

9.1.2 A lot for all other testing shall consist of all material from the same heat, nominal size (excepting length), and condition.

9.1.2.1 Where material cannot be identified by heat, a lot shall consist of not more than 500 lb (227 kg) of material in the same condition and nominal size (excepting length).

9.2 *Test Material Selection:*

9.2.1 *Chemical Analysis*—Representative samples from each lot shall be taken during pouring or subsequent processing.

9.2.1.1 Product (Check) Analysis shall be wholly the responsibility of the purchaser.

9.2.2 *Mechanical and other Properties*—Samples of the material to provide test specimens for mechanical and other properties shall be taken from such locations in each lot as to be representative of that lot. Test specimens shall be taken from material in the final condition.

## 10. Number of Tests

10.1 *Chemical Analysis*—One test per lot.

10.2 *Tension*—One test per lot.

10.3 *Hydrostatic or Nondestructive Electric Test*—Each piece in each lot.

## 11. Specimen Preparation

11.1 *Room Temperature Tensile Specimen*—Material shall be tested in the direction of fabrication. Whenever possible, all pipe and tube shall be tested in full tubular size. When testing in full tubular size is not possible, longitudinal strip specimens, or the largest possible round specimen, shall be used. In the event of disagreement when full tubular testing is not possible, a longitudinal strip specimen with reduced gauge length as contained in Test Methods E8 shall be used.

**TABLE 3 Permissible Variations for Outside Diameter and Wall Thickness of Seamless Cold Worked Pipe and Tube<sup>A,B</sup>**

Nominal Outside diameter, in. (mm)	Permissible Variations				% of Thickness of Specified Minimum Wall	
	Outside Diameter, in. (mm)		% of Thickness of Specified Nominal Wall			
	+	-	+	-	+	-
Over 0.400 (10) to 5/8 (16), excl	0.005 (0.13)	0.005 (0.13)	15.0	15.0	30	0
5/8 (16) to 1 1/2 (38), incl	0.0075 (0.19)	0.0075 (0.19)	10.0	10.0	22	0
Over 1 1/2 (38) to 3 (76), incl	0.010 (0.25)	0.010 (0.25)	10.0	10.0	22	0
Over 3 (76) to 4 1/2 (114), incl	0.015 (0.38)	0.015 (0.38)	10.0	10.0	22	0
Over 4 1/2 (114) to 6 (152), incl	0.020 (0.51)	0.020 (0.51)	12.5	12.5	28	0
Over 6 (152) to 6 3/8 (168), incl	0.025 (0.64)	0.025 (0.64)	12.5	12.5	28	0
Over 6 3/8 (168) to 8 3/4 (219), incl	0.031 (0.79)	0.031 (0.79)	12.5	12.5	28	0

<sup>A</sup> *Ovality*—The permissible variations in this table apply to individual measurements, including out-of-roundness (ovality) except for the following:

For pipe and tube having a nominal wall thickness of 3 % or less of the nominal outside diameter, the mean outside diameter shall conform to the permissible variations of this table and individual measurements (including ovality) shall conform to the plus and minus values of the table, with the values increased by 0.5 % of the nominal outside diameter.

For pipe and tube over 4 1/2 in. (114 mm) in outside diameter with a nominal wall thickness greater than 3 % of the nominal outside diameter, the mean outside diameter shall conform to the permissible variations of this table and individual measurements shall not exceed twice the permissible variations of the table.

<sup>B</sup> *Eccentricity*—The permissible variations in this table apply to individual measurements including eccentricity.

**TABLE 4 Permissible Variations in Length<sup>A</sup>**

Outside Diameter, in. (mm)	Cut Length, in. (mm)	
	Over	Under
Under 2 (50.8)	1/8 (3.2)	0
2 (50.8) and over	3/16 (4.8)	0

<sup>A</sup> These permissible variations in length apply to pipe or tube in straight lengths. They apply to cut lengths up to and including 24 ft (7.3 m). For lengths over 24 ft, an additional over-tolerance of 1/8 in. (3.2 mm) for each 10 ft (3.0 m) or fraction thereof shall be permissible up to a maximum additional over-tolerance of 1/2 in. (12.7 mm).

**12. Test Methods**

12.1 *Chemical Composition*—In case of disagreement, the chemical composition shall be determined in accordance with Test Methods E76.

12.2 *Tension Test*—Tension testing shall be conducted in accordance with Test Methods E8.

12.3 *Hydrostatic or Nondestructive Electric Test*—Each pipe or tube with an outside diameter 1/8 in. (3 mm) and larger and with wall thickness of 0.015 in. (0.38 mm) and over shall be tested by the manufacturer to an internal hydrostatic pressure of 1000 psi (6.9 MPa) provided that the fiber stress calculated in accordance with the following equation does not exceed the allowable fiber stress, *S*, indicated below:

$$P = 2St/D \tag{1}$$

where:

*P* = hydrostatic test pressure, psi (or MPa)  
*S* = allowable fiber stress, for material in the condition (temper) furnished as follows:

<i>Annealed:</i>	
5 in. (127 mm) outside diameter and under	17 500 psi (120 MPa)
Over 5 in. (127 mm) outside diameter	16 700 psi (115 MPa)
<i>Stress-relieved:</i>	
All sizes	21 200 psi (145 MPa)

*t* = minimum wall thickness, in. (or mm), equal to the specified nominal wall minus the permissible minus wall tolerance, or the specified minimum wall thickness, and,  
*D* = outside diameter of the pipe or tube, in. (or mm).

12.3.1 When so agreed upon between the manufacturer and purchaser, pipe or tube may be tested to 1 1/2 times the allowable fiber stress given above.

12.3.2 If any pipe or tube shows leaks during hydrostatic testing, it shall be rejected.

12.4 *Nondestructive Electric Test*—Each pipe or tube shall be examined with a nondestructive electric test in accordance with Specification B829.

12.5 *Rounding Method*—For purposes of determining compliance with the specified limits for requirements of the properties listed in the following table, an observed value, or a calculated value, shall be rounded as indicated below, in accordance with the rounding method of Practice E29:

Test	Rounded Unit for Observed or Calculated Value
Chemical composition and tolerances (when expressed in decimals)	nearest unit in the last right-hand place of figures of the specified limit. If two choices are possible, as when the digits dropped are exactly a 5 or a 5 followed only by zeros, choose the one ending in an even digit with zero defined as an even digit.
Tensile strength, yield strength	nearest 1000 psi (6.9 MPa)
Elongation	nearest 1 %

**13. Inspection**

13.1 Inspection of the material shall be agreed upon between the purchaser and the supplier as part of the purchase contract.

**14. Rejection and Rehearing**

14.1 Material that fails to conform to the requirements of this specification may be rejected. Rejection should be reported to the producer or supplier promptly and in writing. In case of dissatisfaction with the results of the test, the producer or supplier may make claim for a rehearing.

## 15. Certification

15.1 A manufacturer's certification shall be furnished to the purchaser stating that material has been manufactured, tested, and inspected in accordance with this specification, and that the test results on representative samples meet specification requirements. A report of the test results shall be furnished.

## 16. Product Marking

16.1 The following information shall be marked on the material or included on the package, or on a label or tag

attached thereto: The name of the material or UNS number, heat number, condition (temper), this specification number, the size, gross, tare and net weight, consignor and consignee address, contract or order number, or such other information as may be defined in the contract or order.

## 17. Keywords

17.1 seamless pipe; seamless tube; N04400

## SUPPLEMENTARY REQUIREMENTS

The following supplementary requirements shall apply only when specified by the purchaser in the inquiry, contract, or order, for agencies of the U. S. Government.

### S1. Referenced Documents

S1.1 The following documents of the issue in effect on date of material purchased form a part of this specification to the extent referenced herein:

S1.1.1 *Federal Standards:*

Fed. Std. No. 102 Preservation, Packaging and Packing Levels

Fed. Std. No. 123 Marking for Shipment (Civil Agencies)

Fed. Std. No. 182 Continuous Identification Marking of Nickel and Nickel-Base Alloys

S1.1.2 *Military Standard:*

MIL-STD-129 Marking for Shipment and Storage

### S2. Quality Assurance

S2.1 *Responsibility for Inspection:*

S2.1.1 Unless otherwise specified in the contract or purchase order, the manufacturer is responsible for the performance of all inspection and test requirements specified. Except as otherwise specified in the contract or purchase order, the manufacturer may use his own or any other suitable facilities for the performance of the inspection and test requirements unless disapproved by the purchaser at the time the order is

placed. The purchaser shall have the right to perform any of the inspections or tests set forth when such inspections and tests are deemed necessary to assure that the material conforms to prescribed requirements.

### S3. Identification Marking

S3.1 All material shall be properly marked for identification in accordance with Fed. Std. No. 182, except that the ASTM specification number and the alloy number shall be used.

### S4. Preparation for Delivery

S4.1 *Preservation, Packaging, Packing:*

S4.1.1 *Military Agencies*—The material shall be separated by size, composition, grade, or class and shall be preserved and packaged, level A or C, packed level A, B, or C as specified in the contract or purchase order.

S4.1.2 *Civil Agencies*—The requirements of Fed. Std. No. 102 shall be referenced for definitions of the various levels of packaging protection.

S4.2 *Marking:*

S4.2.1 *Military Agencies*—In addition to any special marking required by the contract or purchase order, marking for shipment shall be in accordance with MIL-STD-129.

S4.2.2 *Civil Agencies*—In addition to any special marking required by the contract or purchase order, marking for shipment shall be in accordance with Fed. Std. No. 123.

APPENDIXES

(Nonmandatory Information)

X1. CONVERTER SIZES

X1.1 Small-diameter tube and tube with specified wall thickness 3 % or less of the specified outside diameter in outside diameters 1¼ in. (31.8 mm) and under may be furnished in the conditions listed in Table X1.1 when so specified. The material is furnished in a limited range of sizes and the manufacturer should be consulted as to the various outside diameters and wall thicknesses that may be furnished. Material will have a bright finish. Such material shall conform to the applicable requirements in Table X1.1 and Table X1.2.

**TABLE X1.1 Mechanical Properties<sup>A</sup> of Small-Diameter Tube and Tube with Specified Wall Thickness 3 % or Less of the Specified Outside Diameter (Converter Sizes)**

Condition	Tensile Strength, psi (MPa)	Yield Strength (0.2 % offset) min, psi (MPa)	Elongation in 2 in. or 50 mm, (or 4 <i>D</i> ), min. %
Annealed <sup>B</sup>	85 000 (585) max	28 000 (195)	32
Half-hard <sup>C</sup>	85 000 (585) min	55 000 (380)	12
Full hard <sup>D</sup>	110 000 (760) min	90 000 (620)	3

<sup>A</sup> Not applicable to outside diameters under ½ in. (3.2 mm) and wall thicknesses under 0.015 in. (0.38 mm).

<sup>B</sup> This condition is sometimes designated as "No. 1 Temper."

<sup>C</sup> This condition is sometimes designated as "No. 2 Temper."

<sup>D</sup> This condition is sometimes designated as "No. 3 Temper."

ASMENORMDOC.COM : Click to view the full PDF of ASME BPVC.II.B (ASME BPVC Section II Part B) 2025

**TABLE X1.2 Permissible Variations for Small-Diameter Tube and Tube with Specified Wall Thickness ≤ 3 % of the Specified Outside Diameter (Converter Sizes)<sup>A,B,C,D,E,F,G</sup>**

Specified Outside Diameter, in. (mm)	Outside Diameter		Inside Diameter, in. (mm)		Wall Thickness, %	
	+	-	+	-	+	-
Under 3/32 (2.4)	0.002 (0.05)	0 (0)	0 (0)	0.002 (0.05)	10	10
3/32 to 3/16 (2.4 to 4.8), excl	0.003 (0.08)	0 (0)	0 (0)	0.003 (0.08)	10	10
3/16 to 1/2 (4.8 to 12.7), excl	0.004 (0.10)	0 (0)	0 (0)	0.004 (0.10)	10	10
1/2 to 1 1/4 (12.7 to 31.8), incl	0.005 (0.13)	0 (0)	0 (0)	0.005 (0.13)	10	10

<sup>A</sup> *Ovality, Tube with Specified Wall Thickness > 3 % of the Specified Outside Diameter*—As-Drawn (No. 2 and 3) Tempers—Ovality will be held within the outside diameter tolerances shown in the table.

*Annealed (No. 1) Temper*—Ovality will be held within 2 % of the theoretical average outside diameter.

<sup>B</sup> *Ovality, Tube with Specified Wall Thickness ≤ 3 % of the Specified Outside Diameter*—As-Drawn (No. 2 and 3) Tempers—Up to but not including 1 1/4 in. (31.8 mm) in outside diameter, ovality will be held within 2 % of the theoretical average outside diameter.

*Annealed (No. 1) Temper*—Ovality will be held within 3 % of the theoretical average outside diameter.

<sup>C</sup> *Wall Tolerances, Tube with Specified Wall Thickness ≤ 3 % of the Specified Outside Diameter*—The plus and minus wall tolerance shown in the table shall apply down to and including 0.005 in. (0.13 mm) in wall thickness. For wall thicknesses less than 0.005 in. (0.13 mm), the tolerance shall be ±0.0005 in. (0.013 mm).

<sup>D</sup> *Random Lengths:*

Where nominal random lengths on tubing 1/8 in. (3.2 mm) and larger in outside diameter are specified, a length tolerance of ±3 1/2 ft (106 cm) applies to the nominal length. This is a total spread of 7 ft (210 cm).

Random lengths in sizes 1/8 in. (3.2 mm) and larger in outside diameter shall be subject to a length range of 5 to 24 ft (150 to 730 cm). Long random lengths are subject to a range of 15 to 22 ft (457 to 670 cm).

Random lengths in sizes up to, but not including 1/8 in. (3.2 mm) in outside diameter, and fragile tubes with specified wall thickness ≤ 3 % of the specified outside diameter over this outside diameter are subject to the length range of 1 to 15 ft (30 to 457 cm).

<sup>E</sup> *Cut Lengths*—Tolerances on cut lengths shall be in accordance with Table X1.3.

<sup>F</sup> *Straightness*—Round tubing is subject to a straightness tolerance of one part in 600 (equivalent to a depth of arc of 0.030 in. (0.76 mm) in any 3 ft (91 cm) of length).

<sup>G</sup> When specified, the tolerance spreads of this table may be applied as desired. However, when not specified, the tolerances in this table will apply. It should be noted that inside diameter tolerances are based upon the outside diameter range.

**TABLE X1.3 Tolerances on Cut Lengths of Tube with Specified Wall Thickness ≤ 3 % of the Specified Outside Diameter**

Length, ft (cm)	Tube Size, in. (mm)	Permissible Variations, in. (mm)	
		Over	Under
Under 1 (30)	up to 1.250 (31.8), incl	1/32 (0.8)	0 (0)
1 to 4 (30 to 122), incl	up to 1.250 (31.8), incl	1/16 (1.6)	0 (0)
Over 4 to 10 (122 to 300), incl	up to 1.250 (31.8), incl	3/32 (2.4)	0 (0)
Over 10 (300)	up to 1.250 (31.8), incl	3/16 (4.8)	0 (0)

**X2. PIPE SCHEDULES**

X2.1 The schedules of pipe shown in Table X2.1 are regularly available. Other schedules may be furnished, and the manufacturer should be consulted. Table X2.1 is published for information only.

**TABLE X2.1 Pipe Schedules<sup>A</sup>**

Nominal Pipe Size in.	Outside Diameter in. (mm)	Nominal Wall Thickness, in. (mm)			
		Schedule No. 5 in. (mm)	Schedule No. 10 in. (mm)	Schedule No. 40 in. (mm)	Schedule No. 80 in. (mm)
1/8	0.405 (10.3)	...	0.049 (1.2)	0.068 (1.7)	0.095 (2.4)
1/4	0.540 (13.7)	...	0.065 (1.6)	0.088 (2.2)	0.119 (3.0)
3/8	0.675 (17.1)	...	0.065 (1.6)	0.091 (2.3)	0.126 (3.2)
1/2	0.840 (21.3)	0.065 (1.6)	0.083 (2.1)	0.109 (2.8)	0.147 (3.7)
3/4	1.050 (26.7)	0.065 (1.6)	0.083 (2.1)	0.113 (2.8)	0.154 (3.9)
1	1.315 (33.4)	0.065 (1.6)	0.109 (2.8)	0.133 (3.4)	0.179 (4.5)
1 1/4	1.660 (42.2)	0.065 (1.6)	0.109 (2.8)	0.140 (3.6)	0.191 (4.8)
1 1/2	1.900 (48.3)	0.065 (1.6)	0.109 (2.8)	0.145 (3.7)	0.200 (5.1)
2	2.375 (60.3)	0.065 (1.6)	0.109 (2.8)	0.154 (3.9)	0.218 (5.5)
2 1/2	2.875 (73.0)	0.083 (2.1)	0.120 (3.0)	0.203 (5.2)	0.276 (7.0)
3	3.500 (88.9)	0.083 (2.1)	0.120 (3.0)	0.216 (5.5)	0.300 (7.6)
3 1/2	4.000 (101.6)	0.083 (2.1)	0.120 (3.0)	0.226 (5.7)	0.318 (8.1)
4	4.500 (114.3)	0.083 (2.1)	0.120 (3.0)	0.237 (6.0)	0.337 (8.6)
5	5.563 (141.3)	0.109 (2.8)	0.134 (3.4)	0.258 (6.5)	0.375 (9.5)
6	6.625 (168.3)	0.109 (2.8)	0.134 (3.4)	0.280 (7.1)	0.432 (10.9)
8	8.625 (219.1)	...	...	0.322 (8.2)	0.500 (12.7)

<sup>A</sup> The pipe schedules shown above conform with standards adopted by the American National Standards Institute.

### X3. CONDITIONS AND FINISHES NORMALLY SUPPLIED

X3.1 This appendix lists the conditions and finishes in which pipe and tube (other than converter sizes) are normally supplied. These are subject to change, and the manufacturer should be consulted for the latest information available.

X3.2.2 *Stress-Relieved*—Thermally treated below the annealing temperature to relieve the major portion of the internal stresses, with a thin, light- to medium-dark surface.

#### X3.2 Nickel-Copper Alloy (UNS N04400)

X3.2.1 *Annealed*—Soft, with a dull matte finish.

ASMENORMDOC.COM : Click to view the full PDF of ASME BPVC.II.B (ASME BPVC Section II part B) 2025

**SPECIFICATION FOR NICKEL-CHROMIUM-ALUMINUM  
ALLOY, NICKEL-CHROMIUM-IRON ALLOYS, NICKEL-  
CHROMIUM-COBALT-MOLYBDENUM ALLOY, NICKEL-  
IRON-CHROMIUM-TUNGSTEN ALLOY, AND NICKEL-  
CHROMIUM-MOLYBDENUM-COPPER ALLOY, ROD,  
BAR, AND WIRE**



**SB-166**

(Identical with ASTM Specification B166-19 except for the addition of UNS N06617 heat treatment requirements.  
Certification and test reports have been made mandatory.)

# Specification for Nickel-Chromium-Aluminum Alloy, Nickel-Chromium-Iron Alloys, Nickel-Chromium-Cobalt-Molybdenum Alloy, Nickel- Iron-Chromium-Tungsten Alloy, and Nickel-Chromium- Molybdenum-Copper Alloy Rod, Bar, and Wire

## 1. Scope

1.1 This specification covers nickel-chromium-aluminum alloy, nickel-chromium-iron alloys, nickel-chromium-cobalt-molybdenum alloy, nickel-iron-chromium-tungsten alloy, and nickel-chromium-molybdenum-copper alloy in the form of hot-finished and cold-worked rounds, squares, hexagons, rectangles, and cold-worked wire.

1.2 The values stated in inch-pound units are to be regarded as standard. The values given in parentheses are mathematical conversions to SI units that are provided for information only and are not considered standard.

1.3 The following precautionary caveat pertains only to the test methods portion, Section 12, of this specification: *This standard does not purport to address all of the safety concerns, if any, associated with its use. It is the responsibility of the user of this standard to become familiar with all hazards including those identified in the appropriate Safety Data Sheet (SDS) for this product/material as provided by the manufacturer, to establish appropriate safety, health, and environmental practices and determine the applicability of regulatory limitations prior to use.*

1.4 *This international standard was developed in accordance with internationally recognized principles on standardization established in the Decision on Principles for the Development of International Standards, Guides and Recommendations issued by the World Trade Organization Technical Barriers to Trade (TBT) Committee.*

## 2. Referenced Documents

### 2.1 ASTM Standards:

- B168 Specification for Nickel-Chromium-Aluminum Alloys (UNS N06699), Nickel-Chromium-Iron Alloys (UNS N06600, N06601, N06603, N06690, N06693, N06025, N06045, and N06696), Nickel-Chromium-Cobalt-Molybdenum Alloy (UNS N06617), Nickel-Iron-Chromium-Tungsten Alloy (UNS N06674), Plate, Sheet, and Strip
- B880 Specification for General Requirements for Chemical Check Analysis Limits for Nickel, Nickel Alloys and Cobalt Alloys
- E8/E8M Test Methods for Tension Testing of Metallic Materials
- E18 Test Methods for Rockwell Hardness of Metallic Materials
- E29 Practice for Using Significant Digits in Test Data to Determine Conformance with Specifications
- E38 Methods for Chemical Analysis of Nickel-Chromium and Nickel-Chromium-Iron Alloys (Withdrawn 1989)
- E112 Test Methods for Determining Average Grain Size
- E140 Hardness Conversion Tables for Metals Relationship Among Brinell Hardness, Vickers Hardness, Rockwell Hardness, Superficial Hardness, Knoop Hardness, Scleroscope Hardness, and Leeb Hardness
- E527 Practice for Numbering Metals and Alloys in the Unified Numbering System (UNS)
- E1473 Test Methods for Chemical Analysis of Nickel, Cobalt and High-Temperature Alloys

## 2.2 Federal Standards:

Fed. Std. No. 102 Preservation, Packaging and Packing Levels

Fed. Std. No. 123 Marking for Shipment (Civil Agencies)

Fed. Std. No. 182 Continuous Identification Marking of Nickel and Nickel-Base Alloys

## 2.3 Military Standard:

MIL-STD-129 Marking for Shipment and Storage

## 3. Terminology

### 3.1 Definitions of Terms Specific to This Standard:

3.1.1 *bar, n*—material of rectangular (flats), hexagonal, or square solid section up to and including 10 in. (254 mm) in width and  $\frac{1}{8}$  in. (3.2 mm) and over in thickness in straight lengths.

3.1.2 *rod, n*—material of round solid section furnished in straight lengths.

3.1.2.1 *Discussion*—Hot-worked rectangular bar in widths 10 in. and under may be furnished as hot-rolled plate with sheared or cut edges in accordance with Specification B168, provided the mechanical property requirements of this specification are met.

3.1.3 *wire, n*—a cold-worked solid product of uniform round cross section along its whole length, supplied in coil form.

## 4. Ordering Information

4.1 It is the responsibility of the purchaser to specify all requirements that are necessary for the safe and satisfactory performance of material ordered under this specification. Examples of such requirements include, but are not limited to, the following:

4.1.1 *Alloy Name or UNS Number*—see Table 1.

4.1.2 *ASTM Designation*, including year of issue.

4.1.3 *Section*—Rod (round), bar (square, hexagonal, or rectangular), or wire (round),

4.1.4 *Condition* (see Table 2 and Table 3),

4.1.5 *Finish*,

4.1.6 *Dimensions*, including length (see Tables 4-8),

4.1.7 *Quantity*—feet or number of pieces,

4.1.8 *Certification*—Certification and test reports are required.

4.1.9 *Samples for Product (Check) Analysis*—State whether samples for product (check) analysis shall be furnished, and

4.1.10 *Purchaser Inspection*—If purchaser wishes to witness tests or inspection of material at place of manufacture, the purchase order must so state indicating which test or inspections are to be witnessed.

## 5. Chemical Composition

5.1 The material shall conform to the composition limits specified in Table 1.

5.2 If a product (check) analysis is performed by the purchaser, the material shall conform to the product (check) analysis variations in Specification B880.

## 6. Mechanical Properties and Other Requirements

6.1 *Mechanical Properties*—The material shall conform to the mechanical properties specified in Table 2 for rod and bar and Table 3 (UNS N06600 and N06690 only) for wire.

### 6.2 Grain Size:

6.2.1 Grain size for N06674 shall be 7 or coarser as determined in accordance with Test Methods E112.

## 7. Dimensions and Permissible Variations

7.1 *Diameter, Thickness, or Width*—The permissible variations from the specified dimensions as measured on the diameter or between parallel surfaces of cold-worked rod and bar shall be as prescribed in Table 4; of hot-worked rod and bar as prescribed in Table 5; and of wire as prescribed in Table 6.

7.2 *Out-of-Round*—Hot-worked rods and cold-worked rods (except “forging quality”) all sizes, in straight lengths, shall not be out-of-round by more than one half the total permissible variations in diameter shown in Table 4 and Table 5, except for hot-worked rods  $\frac{1}{2}$  in. (12.7 mm) in diameter and under, which may be out-of-round by the total permissible variations in diameter shown in Table 5. Cold-worked wire shall not be out-of-round by more than one-half the total permissible variations in diameter shown in Table 6.

7.3 *Corners*—Cold-worked bars will have practically exact angles and sharp corners.

7.4 *Machining Allowances for Hot-Worked Materials*—When the surfaces of hot-worked products are to be machined, the allowances prescribed in Table 7 are recommended for normal machining operations.

7.5 *Length*—The permissible variations in length of cold-worked and hot-worked rod and bar shall be as prescribed in Table 8.

7.5.1 Rods and bars ordered to random or nominal lengths will be furnished with either cropped or saw-cut ends; material ordered to cut lengths will be furnished with square saw-cut or machined ends.

7.6 *Straightness*—The permissible variations in straightness of cold-worked rod and bar as determined by the departure from straightness shall be as prescribed in Table 9.

7.6.1 The permissible variations in straightness of hot-worked rod and bar as determined by the departure from straightness shall be as specified in Table 10.

## 8. Workmanship, Finish, and Appearance

8.1 The material shall be uniform in quality and condition, smooth, commercially straight or flat, and free of injurious imperfections.

## 9. Sampling

### 9.1 Lot—Definition:

9.1.1 A lot for chemical analysis shall consist of one heat.

9.1.2 A lot for mechanical properties testing and other requirements shall consist of all material from the same heat, nominal diameter or thickness, and condition.

TABLE 1 Chemical Requirements<sup>A</sup>

Element	Composition Limits, %											
	Alloy N06600	Alloy N06601	Alloy N06617	Alloy N06674	Alloy N06690	Alloy N06693	Alloy N06025	Alloy N06045	Alloy N06603	Alloy N06696	Alloy N06699	Alloy N06235
Nickel	72.0 min	58.0–63.0	44.5 min	remainder <sup>B</sup>	58.0 min	remainder <sup>B</sup>	remainder <sup>B</sup>	45.0 min	remainder <sup>B</sup>	remainder <sup>B</sup>	remainder <sup>B</sup>	remainder <sup>B</sup>
Chromium	14.0–17.0	21.0–25.0	20.0–24.0	21.5–24.5	27.0–31.0	27.0–31.0	24.0–26.0	26.0–29.0	24.0–26.0	28.0–32.0	26.0–30.0	30.0–32.5
Cobalt	...	...	10.0–15.0	...	...	...	...	...	...	...	...	1.0 max
Molybdenum	...	...	8.0–10.0	...	...	...	...	...	...	1.0–3.0	...	5.0–6.2
Iron	6.0–10.0	remainder <sup>B</sup>	3.0 max	20.0–27.0	7.0–11.0	2.5–6.0	8.0–11.0	21.0–25.0	8.0–11.0	2.0–6.0	2.5 max	1.5 max
Manganese	1.0 max	1.0 max	1.0 max	1.50 max	0.5 max	1.0 max	0.15 max	1.0 max	0.15 max	1.0 max	0.50 max	0.3–0.65
Aluminum	...	1.0–1.7	0.8–1.5	...	...	2.5–4.0	1.8–2.4	...	2.4–3.0	...	1.9–3.0	0.2–0.4
Carbon	0.15 max	0.10 max	0.05–0.15	0.01 max	0.05 max	0.15 max	0.15–0.25	0.05–0.12	0.20–0.40	0.15 max	0.005–0.10	0.02–0.06
Copper	0.5 max	1.0 max	0.5 max	...	0.5 max	0.5 max	0.1 max	0.3 max	0.50 max	1.5–3.0	0.50 max	3.5–4.0
Silicon	0.5 max	0.5 max	1.0 max	1.0 max	0.5 max	0.5 max	0.5 max	2.5–3.0	0.50 max	1.0–2.5	0.50 max	0.2–0.6
Sulfur	0.015 max	0.015 max	0.015 max	0.015 max	0.015 max	0.01 max	0.010 max	0.010 max	0.010 max	0.010 max	0.01 max	0.015 max
Titanium	...	...	0.6 max	0.05–0.20	...	1.0 max	0.1–0.2	...	0.01–0.25	1.0 max	0.60 max	0.5 max
Phosphorus	...	...	...	0.030 max	...	...	0.020 max	0.020 max	0.20 max	...	0.02 max	0.03 max
Zirconium	...	...	...	...	...	...	0.01–0.10	...	0.01–0.10	...	0.10 max	...
Yttrium	...	...	...	...	...	...	0.05–0.12	...	0.01–0.15	...	...	...
Boron	...	...	0.006 max	0.0005–0.006	...	...	...	...	...	...	0.008 max	...
Nitrogen	...	...	...	0.02 max	...	...	...	...	...	...	0.05 max	...
Niobium	...	...	...	0.10–0.35	...	0.5–2.5	...	...	...	...	0.50 max	1.0 max
Cerium	...	...	...	...	...	...	...	0.03–0.09	...	...	...	...
Tungsten	...	...	...	6.0–8.0	...	...	...	...	...	...	...	0.60 max

<sup>A</sup> Where ellipses (...) appear in this table, there is no requirement, and the element need neither be analyzed for nor reported.

<sup>B</sup> Element shall be determined arithmetically by difference.

ASME NORMDOC.COM : Click to view the full PDF of ASME BPVC.II.B (ASME BPVC Section II part B) 2025

TABLE 2 Mechanical Properties of Rods and Bars

Condition and Diameter or Distance Between Parallel Surfaces, in. (mm)	Tensile Strength, min, psi (MPa)	Yield Strength (0.2 % offset), min, psi (MPa)	Elongation in 2 in. or 50 mm or 4D, min,%
<i>UNS N06600:</i>			
Cold-worked (as worked):			
Rounds:			
Under 1/2 (12.7)	120 000 (825)	90 000 (620)	7 <sup>A</sup>
1/2 to 1 (12.7 to 25.4), incl	110 000 (760)	85 000 (585)	10
Over 1 to 2 1/2 (25.4 to 63.5), incl	105 000 (725)	80 000 (550)	12
Squares, hexagons, and rectangles:			
1/4 (6.4) and under	100 000 (690)	80 000 (550)	5 <sup>A</sup>
Over 1/4 to 1/2 (6.4 to 12.7), excl	95 000 (655)	70 000 (480)	7
Hot worked (as worked):			
Rounds:			
1/4 to 1/2 (6.4 to 12.7), incl	95 000 (655)	45 000 (310)	20
Over 1/2 to 3 (12.7 to 76.2), incl	90 000 (620)	40 000 (275)	25
Over 3 (76.2)	85 000 (585)	35 000 (240)	30
Squares, hexagons, and rectangles:			
All sizes	85 000 (585)	35 000 (240)	20
Rings and disks <sup>B</sup>	—	—	—
Cold-worked (annealed) or hot-worked (annealed):			
Rods and bars, all sizes	80 000 (550)	35 000 (240)	30 <sup>A</sup>
Rings and disks <sup>C</sup>	—	—	—
Forging Quality:			
All sizes	<i>D</i>	<i>D</i>	<i>D</i>
<i>UNS N06601:</i>			
Cold-worked (annealed) or hot-worked (annealed):			
All products, all sizes	80 000 (550)	30 000 (205)	30
Forging Quality:			
All sizes	<i>D</i>	<i>D</i>	<i>D</i>
<i>UNS N06617:</i>			
Cold-worked (annealed <sup>G</sup> ) or hot-worked (annealed <sup>G</sup> ):			
All products, all sizes	95 000 (655)	35 000 (240)	35
Forging Quality:			
All sizes	<i>D</i>	<i>D</i>	<i>D</i>
<i>UNS N06674</i>			
Cold-worked (annealed <sup>F</sup> ) or hot-worked (annealed <sup>F</sup> ):			
All products, all sizes	86 000 (590)	34 000 (235)	30
Forging Quality:			
All sizes	<i>D</i>	<i>D</i>	<i>D</i>
<i>UNS N06690:</i>			
Cold-worked (as worked):			
Rounds:			
Under 1/2 (12.7)	120 000 (825)	90 000 (620)	7 <sup>A</sup>
1/2 to 1 (12.7 to 25.4), incl	110 000 (760)	85 000 (585)	10
Over 1 to 2 1/2 (25.4 to 63.5), incl	105 000 (725)	80 000 (550)	12
Squares, hexagons, and rectangles:			
1/4 (6.4) and under	100 000 (690)	80 000 (550)	5 <sup>A</sup>
Over 1/4 to 1/2 (6.4 to 12.7), excl	95 000 (655)	70 000 (480)	7
Hot worked (as worked):			
Rounds:			
1/4 to 1/2 (6.4 to 12.7), incl	95 000 (655)	45 000 (310)	20
Over 1/2 to 3 (12.7 to 76.2), incl	90 000 (620)	40 000 (275)	25
Over 3 (76.2)	85 000 (585)	35 000 (240)	30
Squares, hexagons, and rectangles:			
All sizes	85 000 (585)	35 000 (240)	20
Rings and disks <sup>B</sup>	—	—	—
Cold-worked (annealed) or hot-worked (annealed):			
Rods and bars, all sizes	85 000 (586)	35 000 (240)	30 <sup>A</sup>
Rings and disks <sup>C</sup>	—	—	—
Forging Quality:			
All sizes	<i>D</i>	<i>D</i>	<i>D</i>
<i>UNS N06693:</i>			
Cold-worked (annealed) or hot-worked (annealed):			
Rods and bars, all sizes	100 000 (690)	50 000 (345)	30
Forging Quality:			
All sizes	<i>D</i>	<i>D</i>	<i>D</i>
<i>UNS N06603:</i>			
Cold-worked (annealed) or hot-worked (annealed):			
All products, all sizes	94 000 (650)	43 000 (300)	25
Forging Quality:			
All sizes	<i>D</i>	<i>D</i>	<i>D</i>
<i>UNS N06025:</i>			
Cold-worked (annealed) or hot-worked (annealed):			
All products, all sizes	98 000 (680)	39 000 (270)	30
Forging Quality:			
All sizes	<i>D</i>	<i>D</i>	<i>D</i>
<i>UNS N06045:</i>			
Cold-worked (annealed) or hot-worked (annealed):			

TABLE 2 Continued

Condition and Diameter or Distance Between Parallel Surfaces, in. (mm)	Tensile Strength, min, psi (MPa)	Yield Strength (0.2 % offset), min, psi (MPa)	Elongation in 2 in. or 50 mm or 4D, min,%
All products, all sizes	90 000 (620)	35 000 (240)	35
Hot-worked (Annealed): <sup>F</sup>			
Rods and bars, all sizes	75 000 (517)	30 000 (207)	30
Forging Quality:	D	D	D
All sizes			
UNS N06696			
Cold-worked (annealed and water quenched) or hot-worked (annealed and water quenched)	85 000 (586)	35 000 (240)	30
All products, all sizes			
UNS N06699:			
Cold-worked (annealed) or hot-worked (annealed):	89 000 (610)	35 000 (240)	40
All products, all sizes			
Forging Quality:	D	D	D
All sizes			
UNS N06235			
Cold-worked (annealed) or hot-worked (annealed):	90 000 (620)	35 000 (240)	35
All products, all sizes			
Forging Quality:	D	D	D
All sizes			

<sup>A</sup> Not applicable to diameters or cross sections under 3/32 in. (2.4 mm).

<sup>B</sup> Hardness B75 to B100, or equivalent.

<sup>C</sup> Hardness B75 to B95, or equivalent.

<sup>D</sup> Forging quality is furnished to chemical requirements and surface inspection only. No mechanical properties are required.

<sup>E</sup> Solution annealed at a minimum temperature of 2150°F (1175°C) followed by a water quench or rapidly cooled by other means.

<sup>F</sup> High-temperature annealed condition.

<sup>G</sup> Solution anneal is done at 2,100°F to 2,250°F and quenched in water or rapidly cooled by other means.

TABLE 3 Mechanical Properties of Cold-Worked Wire in Coil (Alloys N06600 and N06690 Only)<sup>A</sup>

Condition and Size, in. (mm)	Tensile Strength, psi (MPa)		Wrapping Test
	Min	Max	
Annealed			
Under 0.032 (0.81)	80 000 (552)	115 000 (793)	The wire shall be wrapped eight consecutive turns in a closed helix (pitch approximately equal to the diameter of the wire) around a mandrel as follows: (1) For all annealed and regular temper wire and for spring temper wire 0.229 in. (5.82 mm) and less: Same as diameter of wire. (2) For spring temper wire over 0.229 in. (5.82 mm): Twice the diameter of wire.
0.032 (0.81) and over	80 000 (552)	105 000 (724)	
Cold-worked, regular temper, all sizes	120 000 (827)		The wire shall withstand the wrapping test without fracture or development of a pebbled or orange-peel surface.
Cold-worked, spring temper		165 000 (1138)	
Up to 0.057 (1.45), incl	165 000 (1276)	...	
Over 0.057 (1.45) to 0.114 (2.90), incl	175 000 (1207)	...	
Over 0.114 (2.90) to 0.229 (5.82), incl	170 000 (1172)	...	
Over 0.229 (5.82) to 0.329 (8.36), incl	165 000 (1138)	...	
Over 0.329 (8.36) to 0.375 (9.53), incl	160 000 (1103)	...	
Over 0.375 (9.53) to 0.500 (12.7), incl	155 000 (1069)	...	
Over 0.500 (12.7) to 0.563 (14.3), incl	140 000 (965)	...	

<sup>A</sup> Properties are not applicable to wire after straightening and cutting.

9.1.2.1 Where material cannot be identified by heat, a lot shall consist of not more than 500 lb (227 kg) of material in the same size and condition.

9.2 Test Material Selection:

9.2.1 Chemical Analysis—Representative samples from each lot shall be taken during pouring or subsequent processing.

9.2.1.1 Product (check) analysis shall be wholly the responsibility of the purchaser.

9.2.2 Mechanical Properties and Other Requirements—Samples of the material to provide test specimens for mechanical properties and other requirements shall be taken from such locations in each lot as to be representative of that lot.

10. Number of Tests

10.1 Chemical Analysis—One test per lot.

10.2 Tension—One test per lot.

10.3 Hardness—One test per lot (when required by Footnotes B or C in Table 2).

10.4 Grain Size—One test from one end of one bar or rod from each lot. See 9.1.2.

11. Specimen Preparation

11.1 Tension test specimens shall be taken from material in the final condition and tested in the direction of fabrication.

**TABLE 4 Permissible Variations in Diameter or Distance Between Parallel Surfaces of Cold-Worked Rod and Bar**

Specified Dimension, in. (mm) <sup>A</sup>	Permissible Variations From Specified Dimension, in. (mm)	
	+	-
<b>Rounds:</b>		
1/16 (1.6) to 3/16 (4.8), excl	0	0.002 (0.05)
3/16 (4.8) to 1/2 (12.7), excl	0	0.003 (0.08)
1/2 (12.7) to 15/16 (23.8), incl	0.001 (0.03)	0.002 (0.05)
over 15/16 (23.8) to 1 1/16 (49.2), incl	0.0015 (0.04)	0.003 (0.08)
over 1 1/16 (49.2) to 2 1/2 (63.5), incl	0.002 (0.05)	0.004 (0.10)
<b>Hexagons, squares, rectangles:</b>		
1/2 (12.7) and less	0	0.004 (0.10)
over 1/2 (12.7) to 7/8 (22.2), incl	0	0.005 (0.13)
over 7/8 (22.2) to 1 1/4 (31.8), incl	0	0.007 (0.18)
over 1 1/4 (31.8) to 2 (50.8), incl	0	0.009 (0.23)

<sup>A</sup> Dimensions apply to diameter of rounds, to distance between parallel surfaces of hexagons and squares, and separately to width and thickness of rectangles.

**TABLE 5 Permissible Variations in Diameter or Distance Between Parallel Surfaces of Hot-Worked Rod and Bar**

Specified Dimension, in. (mm) <sup>A</sup>	Permissible Variations from Specified Dimensions, in. (mm)	
	+	-
<b>Rod and bar, hot-worked:</b>		
1 (25.4) and under	0.016 (0.41)	0.016 (0.41)
over 1 (25.4) to 2 (50.8), incl	0.031 (0.79)	0.016 (0.41)
over 2 (50.8) to 4 (101.6), incl	0.047 (1.19)	0.031 (0.79)
over 4 (101.6)	0.125 (3.18)	0.063 (1.60)
<b>Rod, rough-turned or ground:</b>		
under 1 (25.4)	0.005 (0.13)	0.005 (0.13)
1 (25.4) and over	0.031 (0.79)	0
<b>Forging quality rod:<sup>B</sup></b>		
Under 1 (25.4)	0.005 (0.13)	0.005 (0.13)
1 (25.4) and over	0.031 (0.79)	0

<sup>A</sup> Dimensions apply to diameter of rods, to distance between parallel surfaces of hexagons and squares, and separately to width and thickness of rectangles.

<sup>B</sup> Spot grinding is permitted to remove minor surface imperfections. The depth of these spot ground areas shall not exceed 3 % of the diameter of the rod.

**TABLE 6 Permissible Variations in Diameter of Cold-Worked Wire**

Diameter, in. (mm)	Permissible Variations, in. (mm)	
	+ or -	
Up to 0.0044 (0.112), incl	0.0002 (0.005)	
Over 0.0044 (0.112) to 0.0079 (0.201), incl	0.00025 (0.006)	
Over 0.0079 (0.201) to 0.0149 (0.378), incl	0.0003 (0.008)	
Over 0.0149 (0.378) to 0.0199 (0.505), incl	0.0004 (0.010)	
Over 0.0199 (0.505) to 0.031 (0.79), incl	0.0005 (0.013)	
Over 0.031 (0.79) to 0.045 (1.14), incl	0.0006 (0.015)	
Over 0.045 (1.14) to 0.079 (2.01), incl	0.0007 (0.018)	
Over 0.079 (2.01) to 0.1875 (4.76), incl	0.001 (0.025)	
Over 0.1875 (4.76) to 0.3125 (7.93), incl	0.002 (0.051)	
Over 0.3125 (7.93) to 0.563 (14.3), incl	0.003 (0.076)	

11.1.1 All rod, bar, and wire shall be tested in full cross-section size when possible. When a full cross-section size test cannot be performed, the largest possible round specimen shown in Test Methods E8/E8M shall be used. Longitudinal strip specimens shall be prepared in accordance with Test

Methods E8/E8M for rectangular bar up to 1/2 in. (12.7 mm), inclusive, in thicknesses that are too wide to be pulled full size.

11.2 Hardness test and grain size specimens shall be taken from material in the final condition.

NOTE 1—In order that the hardness determinations may be in reasonably close agreement, the following procedure is suggested as follows:  
(1) For rod, under 1/2 in. (12.7 mm) in diameter, hardness readings shall be taken on a flat surface prepared by filing or grinding approximately 1/16 in. (1.6 mm) from the outside surface of the rod.  
(2) For rod, 1/2 in. in diameter and larger, and for hexagonal, square, and rectangular bar, all sizes, hardness readings shall be taken on a cross section midway between the surface and center of the section.

## 12. Test Methods

12.1 The chemical composition, mechanical, and other properties of the material as enumerated in this specification shall be determined, in case of disagreement, in accordance with the following methods:

Test	ASTM Designation
Chemical Analysis	E38, <sup>A</sup> E1473
Tension	E8/E8M
Rockwell Hardness	E18
Hardness Conversion	E140
Grain Size	E112
Rounding Procedure	E29

<sup>A</sup> Methods E38 are to be used only for elements not covered by Test Methods E1473.

12.2 For purposes of determining compliance with the specified limits for requirements of the properties listed in the following table, an observed value or a calculated value shall be rounded in accordance with the rounding method of Practice E29 as follows:

Test	Rounded Unit for Observed or Calculated Value
Chemical composition, hardness, and tolerances (when expressed in decimals)	Nearest unit in the last righthand place of figures of the specified limit. If two choices are possible, as when the digits dropped are exactly a 5, or a 5 followed only by zeros, choose the one ending in an even digit, with zero defined as an even digit.
Tensile strength and yield strength	nearest 1000 psi (6.9 MPa)
Elongation	nearest 1 %

## 13. Inspection

13.1 Inspection of the material shall be made as agreed upon between the manufacturer and the purchaser as part of the purchase contract.

## 14. Rejection and Reheating

14.1 Material that fails to conform to the requirements of this specification may be rejected. Rejection should be reported to the producer or supplier promptly and in writing. In case of dissatisfaction with the results of the test, the producer or supplier may make claim for a reheating.

## 15. Certification

15.1 A manufacturer's certification shall be furnished to the purchaser stating that material has been manufactured, tested, and inspected in accordance with this specification, and that the

**TABLE 7 Normal Machining Allowances for Hot-Worked Material**

Finished-Machined Dimensions for Finishes as Indicated Below, in. (mm) <sup>A</sup>	Normal Machining Allowance, in. (mm)			
	On Diameter, for Rods	Distance Between Parallel Surfaces for Hexagonal and Square Bar	For Rectangular Bar	
			On Thickness	On Width
Hot-worked: <sup>B</sup>				
Up to 7/8 (22.2), incl	1/8 (3.2)	1/8 (3.2)	1/8 (3.2)	3/16 (4.8)
Over 7/8 to 1 1/8 (22.2 to 47.6), incl	1/8 (3.2)	3/16 (4.8)	1/8 (3.2)	3/16 (4.8)
Over 1 1/8 to 2 1/8 (47.6 to 73.0), incl	3/16 (4.8)	1/4 (6.4)	...	3/16 (4.8)
Over 2 1/8 to 3 1/16 (73.0 to 96.8), incl	1/4 (6.4)	...	...	3/16 (4.8)
Over 3 1/16 (96.8)	1/4 (6.4)	...	...	3/8 (9.5)
Hot-worked rods:				
Rough-turned or rough-ground: <sup>C</sup>				
1 9/16 to 4 (23.8 to 101.6), incl in diameter	1/16 (1.6)	...	...	...
Over 4 to 12 (101.6 to 304.8), incl in diameter	1/8 (3.2)	...	...	...

<sup>A</sup> Dimensions apply to diameter of rods, to distance between parallel surfaces of hexagonal and square bar, and separately to width and thickness of rectangular bar.  
<sup>B</sup> The allowances for hot-worked material in Table 5 are recommended for rods machined in lengths of 3 ft (0.91 m) or less and for bars machined in lengths of 2 ft (0.61 m) or less. Hot-worked material to be machined in longer lengths should be specified showing the finished cross-sectional dimension and the length in which the material will be machined in order that the manufacturer may supply material with sufficient oversize, including allowance for out-of-straightness.  
<sup>C</sup> Applicable to 3 ft (0.91 m) max length.

**TABLE 8 Permissible Variations in Length of Rods and Bars**

Random mill lengths:	
Hot-worked	6 to 24 ft (1.83 to 7.31 m) long with not more than 25 weight % between 6 and 9 ft (1.83 and 2.74 m). <sup>A</sup>
Cold-worked	6 to 20 ft (1.83 to 6.1 m) long with not more than 25 weight % between 6 and 10 ft (1.83 and 3.05 m).
Multiple lengths	Furnished in multiples of a specified unit length, within the length limits indicated above. For each multiple, an allowance of 1/4 in. (6.4 mm) will be made for cutting, unless otherwise specified. At the manufacturer's option, individual specified unit lengths may be furnished.
Nominal lengths	Specified nominal lengths having a range of not less than 2 ft (610 mm) with no short lengths allowed. <sup>B</sup>
Cut lengths	A specified length to which all rods and bars will be cut with a permissible variation of plus 1/8 in. (3.2 mm), minus 0 for sizes 8 in. (203 mm) and less in diameter or distance between parallel surfaces. For larger sizes, the permissible variation shall be + 1/4 in. (6.4 mm), - 0.

<sup>A</sup> For hot-worked sections weighing over 25 lb/ft (37 kg/m) and for smooth-forged products, all sections, short lengths down to 2 ft (610 mm) may be furnished.  
<sup>B</sup> For cold-worked rods and bars under 1/2 in. (12.7 mm) in diameter or distance between parallel surfaces ordered to nominal or stock lengths with a 2-ft (610-mm) range, at least 93 % of such material shall be within the range specified; the balance may be in shorter lengths but in no case shall lengths less than 4 ft (1220 mm) be furnished.

**TABLE 9 Permissible Variations in Straightness of Cold-Worked Rods and Bars**

Specified Diameter or Distance Between Parallel Surfaces, in. (mm) <sup>A</sup>	Permissible Variations in Lengths Indicated, in. (mm)
Rounds:	Depth of Chord:
1/2 (12.7) to 2 1/2 (63.5), incl	0.030 (0.76) per ft (305 mm) of length
Hexagons, squares, rectangles:	
1/2 (12.7) to 2 (50.8), incl	0.030 (0.76) per ft (305 mm) of length

<sup>A</sup> Material under 1/2 in. (12.7 mm) shall be reasonably straight and free of sharp bends and kinks.

**TABLE 10 Permissible Variations in Straightness of Hot-Worked Rods and Bars<sup>A</sup>**

Finish	Permissible Variations, in./ft (mm/m) <sup>B</sup>
Rods and bars, hot-worked	0.050 (4.2) <sup>C</sup>
Rounds hot-worked, rough-ground, or rough-turned	0.050 (4.2) <sup>C</sup>

<sup>A</sup> Not applicable to forging quality.  
<sup>B</sup> Material under 1/2 in. (12.7 mm) shall be reasonably straight and free of sharp bends and kinks.  
<sup>C</sup> The maximum curvature (depth of chord) shall not exceed the values indicated multiplied by the length in feet.

test results on representative samples meet specification requirements. A report of the test results shall be furnished.

**16. Product Marking**

16.1 The following shall be marked on the material or included on the package, or on a label or tag attached thereto: the name of the material or UNS Number, heat number, condition (temper), this specification number, the size, gross,

tare, and net weight, consignor and consignee address, contract or order number, or such other information as may be defined in the contract or order.

**17. Keywords**

17.1 bar; rod; wire; UNS N06025; UNS N06045; UNS N06235; UNS N06600; UNS N06601; UNS N06603; UNS N06617; UNS N06674; UNS N06690; UNS N06693; UNS N06696; UNS N06699

## SUPPLEMENTARY REQUIREMENTS

### SUPPLEMENTARY REQUIREMENTS FOR SPECIAL END USES

#### S1. Special End Uses

S1.1 When material is intended for nuclear applications or other critical end uses, or when any special requirements are to apply, the manufacturer shall be notified at the time of placement of the inquiry or order to determine if material of quality and inspection procedures normally employed for commercial material to this specification is adequate. In the

event that more critical quality or more rigid inspection standards than those called out in this specification are indicated, the manufacturer and the purchaser shall agree upon such standards prior to production.

### SUPPLEMENTARY REQUIREMENTS FOR U.S. GOVERNMENT

The following supplementary requirements shall apply only when specified by the purchaser in the inquiry, contract, or order for agencies of the U.S. Government.

#### S2. Referenced Documents

S2.1 The following documents of the issue in effect on date of material purchased form a part of this specification to the extent referenced herein: Federal Standards 102, 123, and 182 and Military Standard MIL-STD-129.

#### S3. Quality Assurance

##### S3.1 *Responsibility for Inspection:*

S3.1.1 Unless otherwise specified in the contract or purchase order, the manufacturer is responsible for the performance of all inspection and test requirements specified. Except as otherwise specified in the contract or purchase order, the manufacturer may use his own or any other suitable facilities for the performance of the inspection and test requirements unless disapproved by the purchaser at the time the order is placed. The purchaser shall have the right to perform any of the inspections or tests set forth when such inspections and tests are deemed necessary to ensure that the material conforms to prescribed requirements.

#### S4. Identification Marking

S4.1 All material shall be properly marked for identification in accordance with Fed. Std. No. 182, except that the ASTM specification number and the alloy number shall be used.

#### S5. Preparation for Delivery

##### S5.1 *Preservation, Packaging, Packing:*

S5.1.1 *Military Agencies*—The material shall be separated by size, composition, grade, or class and shall be preserved and packaged, level A or C, packed level A, B, or C as specified in the contract or purchase order.

S5.1.2 *Civil Agencies*—The requirements of Fed. Std. No. 102 shall be referenced for definitions of the various levels of packaging protection.

##### S5.2 *Marking:*

S5.2.1 *Military Agencies*—In addition to any special marking required by the contract or purchase order, marking for shipment shall be in accordance with MIL-STD-129.

S5.2.2 *Civil Agencies*—In addition to any special marking required by the contract or purchase order, marking for shipment shall be in accordance with Fed. Std. No. 123.

## APPENDIX

## (Nonmandatory Information)

## X1. PROCURABLE CONDITIONS AND FINISHES

X1.1 The various conditions and finishes in which rod and bar are procurable are as follows:

X1.1.1 *Hot-Worked*—With a tightly adherent, dark oxide surface.

X1.1.2 *Hot-Worked, Rough-Ground*—Similar to X1.1.1 except rough-ground.

X1.1.3 *Hot-Worked, Rough-Turned*—Similar to X1.1.1 except rough-turned with a broad-nosed tool similar to a bar peeling operation and thus may not be straight. Intended generally for machining where an overhauled surface is desired, essentially for machined step down shafts or parts machined in short lengths of 3 ft (0.91 m) or less.

X1.1.4 *Hot-Worked, Forging Quality*—Rough-turned and spot-ground, as necessary, for sizes 1 in. (25.4 mm) in diameter and over; rough ground and spot ground for sizes under 1 in. in diameter. Material is selected from heats of known, good hot malleability.

NOTE X1.1—For sizes 2½ in. (63.5 mm) in diameter and less,

coldworked rod may be used also for forging by virtue of the fact that such rod has been overhauled for removal of mechanical surface defects prior to cold-working. In such cases, the user should run pilot forging tests to ensure himself that such material has the desired hot malleability range.

X1.1.5 *Hot-Worked, Annealed*—Soft, with a tightly adherent dark oxide.

X1.1.6 *Hot-Worked, Annealed, and Pickled*—Same as X1.1.5 except descaled for removal of mill oxide. Provides for better surface inspection than does hot-worked material and often employed where welding is involved where removal of mill oxide is desired.

NOTE X1.2—Annealing prior to pickling may be required in order to reduce the mill oxide since uniform pickling of an unreduced oxide is difficult.

X1.1.7 *Cold-Worked, As Worked*—Hot-worked, overhauled, cold-worked, and straightened with a smooth, bright finish.

X1.1.8 *Cold-Worked, Annealed, and Pickled*—Hot-worked, overhauled, cold-worked, annealed, descaled, and straightened. Annealed for softness and with a dull matte finish.

**SPECIFICATION FOR NICKEL-CHROMIUM-ALUMINUM  
ALLOYS (UNS N06699), NICKEL-CHROMIUM-IRON  
ALLOYS (UNS N06600, N06601, N06603, N06690,  
N06693, N06025, N06045, AND N06696), AND NICKEL-  
CHROMIUM-COBALT-MOLYBDENUM ALLOY (UNS  
N06617), NICKEL-IRON-CHROMIUM-TUNGSTEN ALLOY  
(UNS N06674), AND NICKEL-CHROMIUM-  
MOLYBDENUM-COPPER ALLOY (UNS N06235)  
SEAMLESS PIPE AND TUBE**



SB-167

(25)

(Identical with ASTM Specification B167-18 except for the addition of UNS N06617 heat treatment requirements.)

**Specification for  
Nickel-Chromium-Aluminum Alloys (UNS N06699), Nickel-  
Chromium-Iron Alloys (UNS N06600, N06601, N06603,  
N06690, N06693, N06025, N06045, and N06696), Nickel-  
Chromium-Cobalt-Molybdenum Alloy (UNS N06617), Nickel-  
Iron-Chromium-Tungsten Alloy (UNS N06674), and Nickel-  
Chromium-Molybdenum-Copper Alloy (UNS N06235)  
Seamless Pipe and Tube**

### 1. Scope

1.1 This specification covers nickel-chromium-aluminum alloys (UNS N06699), nickel-chromium-iron alloys (UNS N06600, N06601, N06603, N06690, N06693, N06025, N06045, and N06696), nickel-chromium-cobalt-molybdenum alloy (UNS N06617), nickel-iron-chromium-tungsten alloy (UNS N06674), and nickel-chromium-molybdenum-copper alloy (UNS N06235) in cold-worked annealed, hot-worked annealed, and hot-finished seamless pipe and tube intended for general corrosion resistant and heat resistant applications.

1.2 The values stated in inch-pound units are to be regarded as standard. The values given in parentheses are mathematical conversions to SI units that are provided for information only and are not considered standard.

1.3 The following safety hazards caveat pertains only to the test methods portion, Section 13, of this specification: *This standard does not purport to address all of the safety concerns, if any, associated with its use. It is the responsibility of the user of this standard to become familiar with all hazards including those identified in the appropriate Safety Data Sheet (SDS) for this product/material as provided by the manufacturer, to*

*establish appropriate safety, health, and environmental practices, and determine the applicability of regulatory limitations prior to use.*

1.4 *This international standard was developed in accordance with internationally recognized principles on standardization established in the Decision on Principles for the Development of International Standards, Guides and Recommendations issued by the World Trade Organization Technical Barriers to Trade (TBT) Committee.*

### 2. Referenced Documents

#### 2.1 ASTM Standards:

- B829 Specification for General Requirements for Nickel and Nickel Alloys Seamless Pipe and Tube
- B880 Specification for General Requirements for Chemical Check Analysis Limits for Nickel, Nickel Alloys and Cobalt Alloys
- E8/E8M Test Methods for Tension Testing of Metallic Materials
- E29 Practice for Using Significant Digits in Test Data to Determine Conformance with Specifications
- E38 Methods for Chemical Analysis of Nickel-Chromium and Nickel-Chromium-Iron Alloys (Withdrawn 1989)
- E112 Test Methods for Determining Average Grain Size
- E527 Practice for Numbering Metals and Alloys in the Unified Numbering System (UNS)

E1473 Test Methods for Chemical Analysis of Nickel, Cobalt and High-Temperature Alloys

#### 2.2 Federal Standards:

Fed. Std. No. 102 Preservation, Packaging and Packing Levels

Fed. Std. No. 123 Marking for Shipment (Civil Agencies)

Fed. Std. No. 182 Continuous Identification Marking of Nickel and Nickel-Base Alloys

#### 2.3 Military Standard:

MIL-STD-129 Marking for Shipment and Storage

### 3. Terminology

#### 3.1 Definitions of Terms Specific to This Standard:

3.1.1 *average diameter, n*—the average of the maximum and minimum outside diameters, as determined at any one cross section of the pipe or tube.

3.1.2 *pipe, n*—tube conforming to the particular dimensions commercially known as pipe sizes. See Table X2.1.

3.1.3 *seamless pipe or tube, n*—a pipe or tube produced with a continuous periphery in all stages of the operations.

3.1.4 *tube, n*—a hollow product of round or any other cross section having a continuous periphery.

### 4. Ordering Information

4.1 It is the responsibility of the purchaser to specify all requirements that are necessary for the safe and satisfactory performance of material ordered under this specification. Examples of such requirements include, but are not limited to, the following:

4.1.1 *Alloy Name or UNS Number*—see Table 1,

4.1.2 *ASTM Designation*, including year of issue,

4.1.3 *Condition* (see Appendix X3),

4.1.4 *Finish* (see Appendix X3),

4.1.5 *Dimensions*:

4.1.5.1 *Tube*—Specify outside diameter and nominal or minimum wall,

4.1.5.2 *Pipe*—Specify standard pipe size and schedule,

4.1.5.3 *Length*—Cut to length or random,

4.1.6 *Quantity*—Feet or number of pieces,

4.1.7 *Hydrostatic Test or Nondestructive Electric Test*—Specify type of test (see 7.2).

4.1.8 *Hydrostatic Pressure Requirements*—Specify test pressure if other than required by 13.3.1,

4.1.9 *Samples for Product (Check) Analysis*—State whether samples for product (check) analysis should be furnished (see 5.2),

4.1.10 *Purchaser Inspection*—If purchaser wishes to witness tests or inspection of material at place of manufacture, the purchase order must so state indicating which tests or inspections are to be witnessed (Section 14), and

4.1.11 *Small-Diameter Tube and Tube with Specified Wall Thickness 3 % or Less of the Specified Outside Diameter (Converter Sizes)*—See Appendix X1.

### 5. Chemical Composition

5.1 The material shall conform to the composition limits specified in Table 1.

5.2 If a product (check) analysis is performed by the purchaser, the material shall conform to the product (check) analysis variations in Specification B880.

### 6. Heat Treatment

6.1 Heat treatment of N06674 after cold-working or hot-working shall be solution annealing by heating to 2150°F (1175°C) minimum, followed by quenching in water or rapidly cooling by other means.

### 7. Mechanical Properties and Other Requirements

7.1 *Tensile Test*—The material shall conform to the tensile properties specified in Table 2.

7.1.1 Tensile properties for material specified as small-diameter tube and tube with specified wall thickness 3 % or less of the specified outside diameter (converter sizes) shall be as prescribed in Table X1.1.

7.2 *Hydrostatic or Nondestructive Electric Test*—Each pipe or tube shall be subjected to either the hydrostatic test or the nondestructive electric test. The type of test to be used shall be at the option of the manufacturer, unless otherwise specified in the purchase order.

#### 7.3 Grain Size:

7.3.1 Grain size for N06674 shall be 7 or coarser, as determined in accordance with Test Methods E112.

### 8. Dimensions and Permissible Variations

8.1 *Diameter, Wall Thickness, and Length*—The permissible variations in the outside diameter and wall thickness shall conform to the permissible variations prescribed in the Permissible Variations for Outside Diameter and Wall Thickness of Seamless Cold-Worked Pipe and Tube, Permissible Variations for Outside Diameter and Wall Thickness of Hot-Finished Tube, and Permissible Variations for Outside Diameter and Wall Thickness of Seamless Hot-Worked Pipe tables in Specification B829. The permissible variations in the length shall conform to the permissible variations prescribed in the Permissible Variations in Length table in Specification B829.

8.2 Permissible variations for material specified as small-diameter and light-wall tube (converter size) shall conform to the permissible variations prescribed in Table X1.2.

### 9. Workmanship, Finish, and Appearance

9.1 The material shall be uniform in quality and temper, smooth, commercially straight, and free of injurious imperfections.

### 10. Sampling

#### 10.1 Lot Definition:

10.1.1 A lot for chemical analysis shall consist of one heat.

10.1.2 A lot for all other testing shall consist of all material from the same heat, nominal size (excepting length), and condition.

TABLE 1 Chemical Requirements<sup>A</sup>

Element	Composition Limits, %											
	Alloy N06025	Alloy N06045	Alloy N06600	Alloy N06601	Alloy N06603	Alloy N06617	Alloy N06674	Alloy N06690	Alloy N06693	Alloy N06696	Alloy N06699	Alloy N06235
Nickel	remainder <sup>B</sup>	45.0 min	72.0 min	58.0–63.0	remainder <sup>B</sup>	44.5 min	remainder <sup>B</sup>	58.0 min	remainder <sup>B</sup>	remainder <sup>B</sup>	remainder <sup>B</sup>	remainder <sup>B</sup>
Chromium	24.0–26.0	26.0–29.0	14.0–17.0	21.0–25.0	24.0–26.0	20.0–24.0	21.5–24.5	27.0–31.0	27.0–31.0	28.0–32.0	26.0–30.0	30.0–32.5
Iron	8.0–11.0	21.0–25.0	6.0–10.0	remainder <sup>B</sup>	8.0–11.0	3.0 max	20.0–27.0	7.0–11.0	2.5–6.0	2.0–6.0	2.5 max	1.5 max
Manganese	0.15 max	1.0 max	1.0 max	1.5 max	0.15 max	1.0 max	1.50 max	0.5 max	1.0 max	1.0 max	0.50 max	0.3–0.65
Molybdenum	...	...	...	...	...	8.0–10.0	...	...	...	1.0–3.0	...	5.0–6.2
Cobalt	...	...	...	...	...	10.0–15.0	...	...	...	...	...	1.0 max
Aluminum	1.8–2.4	...	...	1.0–1.7	2.4–3.0	0.8–1.5	...	...	2.5–4.0	...	1.9–3.0	0.2–0.4
Carbon	0.15–0.25	0.05–0.12	0.15 max	0.10 max	0.20–0.40	0.05–0.15	0.10 max	0.05 max	0.15 max	0.15 max	0.005–0.10	0.02–0.06
Copper	0.1 max	0.3 max	0.5 max	1.0 max	0.50 max	0.5 max	...	0.5 max	0.5 max	1.5–3.0	0.50 max	3.5–4.0
Boron	...	...	...	...	...	0.006 max	0.0005–0.006	...	...	...	0.008 max	...
Silicon	0.5 max	2.5–3.0	0.5 max	0.5 max	0.50 max	1.0 max	1.0 max	0.5 max	0.5 max	1.0–2.5	0.50 max	0.2–0.6
Sulfur	0.010 max	0.010 max	0.015 max	0.015 max	0.010 max	0.015 max	0.015 max	0.015 max	0.01 max	0.010 max	0.01 max	0.015 max
Titanium	0.1–0.2	...	...	...	0.1–0.25	0.6 max	0.05–0.20	...	1.0 max	1.0 max	0.60 max	0.5 max
Niobium	...	...	...	...	...	...	0.10–0.35	...	0.5–2.5	...	0.50 max	1.0 max
Phosphorous	0.020 max	0.020 max	...	...	0.020 max	...	0.030 max	...	...	...	0.02 max	0.03 max
Zirconium	0.01–0.10	...	...	...	0.01–0.10	...	...	...	...	...	0.10 max	...
Yttrium	0.05–0.12	...	...	...	0.01–0.15	...	...	...	...	...	...	...
Cerium	...	0.03–0.09	...	...	...	...	...	...	...	...	...	...
Nitrogen	...	...	...	...	...	...	0.02 max	...	...	...	0.05 max	...
Tungsten	...	...	...	...	...	...	6.0–8.0	...	...	...	...	0.60 max

<sup>A</sup> Where ellipses (...) appear in this table, there is no requirement and the element need neither be analyzed for nor reported.

<sup>B</sup> Element shall be determined arithmetically by difference.

ASME NORMATIVES : Click to view the full PDF of ASME BPVC.II.B (ASME BPVC Section II part B) 2025

TABLE 2 Mechanical Properties

Condition and Size	Tensile Strength, min psi (MPa)	Yield Strength (0.2 % offset), min, psi (MPa)	Elongation in 2 in. or 50 mm or 4D min,%
<i>UNS N06025:</i> Hot-worked annealed or cold worked annealed (all sizes)	98 000 (680)	39 000 (270)	30
<i>UNS N06045:</i> Hot-worked annealed or cold-worked annealed (all sizes)	90 000 (620)	35 000 (240)	35
<i>UNS N06600:</i> Hot-worked or hot- worked annealed: 5 in. (127 mm) in outside diameter and under	80 000 (550)	30 000 (205)	35
Over 5 in. (127 mm) in outside diameter	75 000 (515)	25 000 (170)	35
Cold-worked annealed: 5 in. (127 mm) in outside diameter and under	80 000 (550)	35 000 (240)	30
Over 5 in. (127 mm) in outside diameter	80 000 (550)	30 000 (205)	35
<i>UNS N06601:</i> Cold-worked annealed or hot-worked annealed: All sizes	80 000 (550)	30 000 (205)	30
<i>UNS N06603:</i> Hot-worked annealed or cold worked annealed (all sizes)	94 000 (650)	43 000 (300)	25
<i>UNS N06617:</i> Cold-worked annealed <sup>A</sup> or hot-worked annealed <sup>A</sup> : All sizes	95 000 (665)	35 000 (240)	35
<i>UNS N06674:</i> Cold-worked annealed or hot-worked annealed: All sizes	86 000 (590)	34 000 (235)	30
<i>UNS N06690:</i> Hot-worked or hot- worked annealed: 5 in. (127 mm) in outside diameter and under	85 000 (586)	30 000 (205)	35
Over 5 in. (127 mm) in outside diameter	75 000 (515)	25 000 (170)	35
Cold-worked annealed: 5 in. (127 mm) in outside diameter and under	85 000 (586)	35 000 (240)	30
Over 5 in. (127 mm) in outside diameter	85 000 (586)	30 000 (205)	35
<i>UNS N06693:</i> Cold-worked annealed or hot-worked annealed: 5 in. (127 mm) in outside diameter and under	100 000 (690)	50 000 (345)	30
<i>UNS N06696</i> Cold-worked annealed (all sizes)	85 000 (586)	35 000 (240)	30
<i>UNS N06235</i> Hot-worked annealed or cold worked annealed (all sizes)	90 000 (620)	35 000 (240)	35
<i>UNS N06699</i>			

TABLE 2 Continued

Condition and Size	Tensile Strength, min psi (MPa)	Yield Strength (0.2 % offset), min, psi (MPa)	Elongation in 2 in. or 50 mm or 4D min,%
Hot-worked annealed or cold worked annealed (all sizes)	89 000 (610)	35 000 (240)	40

<sup>A</sup>Solution anneal is done at 2,100°F to 2,250°F and quenched in water or rapidly cooled by other means.

10.1.2.1 Where material cannot be identified by heat, a lot shall consist of not more than 500 lb (227 kg) of material in the same condition and nominal size (excepting length).

10.2 Test Material Selection:

10.2.1 Chemical Analysis—Representative samples from each lot shall be taken during pouring or subsequent processing.

10.2.1.1 Product (check) analysis shall be wholly the responsibility of the purchaser.

10.2.2 Mechanical and Other Properties—Samples of the material to provide test specimens for mechanical and other properties shall be taken from such locations in each lot as to be representative of that lot. Test specimens shall be taken from material in the final condition.

11. Number of Tests

11.1 Chemical Analysis—One test per lot.

11.2 Tension—One test per lot.

11.3 Hydrostatic or Nondestructive Electric Test—Each piece in each lot.

12. Specimen Preparation

12.1 Room-Temperature Tension Specimen—Material shall be tested in the direction of fabrication. Whenever possible, all pipe and tube shall be tested in full tubular size. When testing in full tubular size is not possible, longitudinal strip specimens, or the largest possible round specimen, shall be used. In the event of disagreement when full tubular testing is not possible, a longitudinal strip specimen with reduced gage length as contained in Test Methods E8/E8M shall be used.

13. Test Methods

13.1 Chemical Composition—In case of disagreement, the chemical composition shall be determined in accordance with Test Methods E1473 or Methods E38. Methods E38 is to be used only for elements not covered by Test Methods E1473.

13.2 Tension Test—Tension testing shall be conducted in accordance with Test Methods E8/E8M.

13.3 Hydrostatic Test—Each pipe or tube with an outside diameter 1/8 in. (3 mm) and larger and with wall thickness of 0.015 in. (0.38 mm) and over shall be tested by the manufacturer to an internal hydrostatic pressure of 1000 psi (6.9 MPa) provided that the fiber stress calculated in accordance with the following equation does not exceed the allowable fiber stress, S, indicated as follows:

$$P = 2St/D \tag{1}$$

where:

P = hydrostatic test pressure, psi (or MPa),

S = allowable fiber stress, for material in the condition (temper) furnished as follows:

Hot-worked or hot-worked annealed:

UNS N06025	24 000 (165 MPa)
UNS N06045	22 500 (155 MPa)
UNS N06600	20 000 (140 MPa)
UNS N06601	20 000 (140 MPa)
UNS N06603	24 000 (165 MPa)
UNS N06617	23 700 (163 MPa)
UNS N06690	21 200 (146 MPa)
UNS N06674	21 500 (148 MPa)
UNS N06693	25 000 (172 MPa)
UNS N06235	22 500 (155 MPa)
UNS N06699	22 100 (152 MPa)

Over 5 in. outside diameter:

UNS N06600	16 700 (115 MPa)
UNS N06690	16 700 (115 MPa)

Cold-worked annealed—All sizes:

UNS N06025	24 500 (169 MPa)
UNS N06045	22 500 (155 MPa)
UNS N06600	20 000 (140 MPa)
UNS N06601	20 000 (140 MPa)
UNS N06674	21 500 (148 MPa)
UNS N06690	21 200 (146 MPa)
UNS N06693	21 200 (146 MPa)
UNS N06696	21 200 (146 MPa)
UNS N06235	22 500 (155 MPa)
UNS N06699	22 100 (152 MPa)

t = minimum wall thickness, in. (or mm), equal to the specified nominal wall minus the permissible minus wall tolerance, or the specified minimum wall thickness, and,

D = outside diameter of the pipe or tube, in. (or mm).

13.3.1 When so agreed upon between the manufacturer and purchaser, pipe or tube may be tested to 1½ times the allowable fiber stress given above.

13.3.2 If any pipe or tube shows leaks during hydrostatic testing, it shall be rejected.

13.4 Nondestructive Electric Test—Each pipe or tube shall be examined with a nondestructive electric test in accordance with Specification B829.

13.5 Grain Size—Grain size determinations, to demonstrate compliance with 7.3.1, shall be made on one end of one finished tube from each lot. See 10.1.2.

13.6 Rounding Method—For purposes of determining compliance with the specified limits for requirements of the properties listed in the following table, an observed value, or a calculated value, shall be rounded as indicated below, in accordance with the rounding method of Practice E29:

Test	Rounded Unit for Observed or Calculated Value
Chemical composition and tolerances (when expressed in decimals)	nearest unit in the last right-hand place of figures of the specified limit. If two choices are possible, as when the digits dropped are exactly a 5 or a 5 followed only by zeros, choose the one ending in an even digit with zero defined as an even digit.
Tensile strength, yield strength	nearest 1000 psi (6.9 MPa)
Elongation	nearest 1 %

#### 14. Inspection

14.1 Inspection of the material shall be agreed upon between the purchaser and the supplier as part of the purchase contract.

#### 15. Rejection and Rehearing

15.1 Material that fails to conform to the requirements of this specification may be rejected. Rejection should be reported to the producer or supplier promptly and in writing. In case of dissatisfaction with the results of the test, the producer or supplier may make claim for a rehearing.

#### 16. Certification

16.1 A manufacturer's certification shall be furnished to the purchaser stating that material has been manufactured, tested, and inspected in accordance with this specification, and that the test results on representative samples meet specification requirements. A report of the test results shall be furnished.

#### 17. Product Marking

17.1 The following information shall be marked on the material or included on the package, or on a label or tag attached thereto: The name of the material or UNS number, heat number, condition (temper), this specification number, the size, gross, tare and net weight, consignor and consignee address, contract or order number, or such other information as may be defined in the contract or order.

#### 18. Keywords

18.1 seamless pipe; seamless tube; UNS N06025; UNS N06045; UNS N06600; UNS N06601; UNS N06603; UNS N06617; UNS N06674; UNS N06690; UNS N06693; UNS N06696; UNS N06235; UNS N06699

### SUPPLEMENTARY REQUIREMENTS

The following supplementary requirements shall apply only when specified by the purchaser in the inquiry, contract, or order, for agencies of the U. S. Government.

#### S1. Referenced Documents

S1.1 The following documents of the issue in effect on date of material purchased form a part of this specification to the extent referenced herein: Federal Standards 102, 123, and 182 and Military Standard MIL-STD-129.

#### S2. Quality Assurance

##### S2.1 Responsibility for Inspection:

S2.1.1 Unless otherwise specified in the contract or purchase order, the manufacturer is responsible for the performance of all inspection and test requirements specified. Except as otherwise specified in the contract or purchase order, the manufacturer may use his own or any other suitable facilities for the performance of the inspection and test requirements unless disapproved by the purchaser at the time the order is placed. The purchaser shall have the right to perform any of the inspections or tests set forth when such inspections and tests are deemed necessary to ensure that the material conforms to prescribed requirements.

#### S3. Identification Marking

S3.1 All material shall be properly marked for identification in accordance with Fed. Std. No. 182, except that the ASTM specification number and the alloy number shall be used.

#### S4. Preparation for Delivery

##### S4.1 Preservation, Packaging, Packing:

S4.1.1 *Military Agencies*—The material shall be separated by size, composition, grade, or class and shall be preserved and packaged, level A or C, packed level A, B, or C as specified in the contract or purchase order.

S4.1.2 *Civil Agencies*—The requirements of Fed. Std. No. 102 shall be referenced for definitions of the various levels of packaging protection.

##### S4.2 Marking:

S4.2.1 *Military Agencies*—In addition to any special marking required by the contract or purchase order, marking for shipment shall be in accordance with MIL-STD-129.

S4.2.2 *Civil Agencies*—In addition to any special marking required by the contract or purchase order, marking for shipment shall be in accordance with Fed. Std. No. 123.

## APPENDIXES

## (Nonmandatory Information)

## X1. CONVERTER SIZES

X1.1 Small-diameter tube and tube with specified wall thickness 3 % or less of the specified outside diameter in outside diameters 1/4 in. (31.8 mm) and under may be furnished in the conditions listed in Table X1.1 when so specified. The material is furnished in a limited range of sizes

and the manufacturer shall be consulted as to the various outside diameters and wall thicknesses that may be furnished. Material will have a bright finish. Such material shall conform to the applicable requirements in Table X1.1 and Table X1.2.

**TABLE X1.1 Mechanical Properties<sup>A</sup> of Small-Diameter Tube and Tube with Specified Wall Thickness  $\leq$  3 % of the Specified Outside Diameter (Converter Sizes)**

Condition	Tensile Strength, psi (MPa)	Yield Strength (0.2 % offset) min, psi (MPa)	Elongation in 2 in. or 50 mm, min, %
<i>UNS N06600:</i> Annealed <sup>B,C</sup>	80 000 (550) to 110 000 (760)	35 000 (240)	30
Half-hard <sup>D</sup>	105 000 (725) min	55 000 (380)	13
Full-hard <sup>E</sup>	130 000 (895) min	105 000 (725)	4
<i>UNS N06601:</i> Annealed <sup>B,C</sup>	80 000 (550) to 110 000 (760)	30 000 (205)	30
<i>UNS N06601:</i> <i>UNS N06603:</i> Annealed <sup>B,C</sup>	94 000 (650) to 140 000 (965)	43 000 (300)	25
<i>UNS N06617:</i> Annealed <sup>B,C</sup>	95 000 (665) to 110 000 (760)	35 000 (240)	35
<i>UNS N06690:</i> Annealed <sup>B,C</sup>	85 000 (586) to 110 000 (760)	35 000 (240)	30
Half-hard <sup>D</sup>	105 000 (725) min	55 000 (380)	13
Full-hard <sup>E</sup>	130 000 (895) min	105 000 (725)	4
<i>UNS N06025:</i> Annealed <sup>B,C</sup>	98 000 (680) to 125 000 (860)	39 000 (270)	30
<i>UNS N06045:</i> Annealed <sup>B,C</sup>	90 000 (620) to 120 000 (830)	35 000 (240)	35

<sup>A</sup> Not applicable to outside diameters under 1/8 in. (3.2 mm) and wall thicknesses under 0.015 in. (0.38 mm).

<sup>B</sup> This condition is sometimes designated as "No. 1 Temper."

<sup>C</sup> The minimum tensile strength value applies only to tubing in straight lengths.

<sup>D</sup> This condition is sometimes designated as "No. 2 Temper."

<sup>E</sup> This condition is sometimes designated as "No. 3 Temper."

**TABLE X1.2 Permissible Variations for Small-Diameter Tube and Tube with Specified Wall Thickness ≤ 3 % of the Specified Outside Diameter (Converter Sizes)<sup>A,B,C,D,E,F,G</sup>**

Specified Outside Diameter, in. (mm)	Outside Diameter		Inside Diameter		Wall thickness, %	
	+	-	+	-	+	-
		in. (mm)				
Under 3/32 (2.4)	0.002 (0.05)	0	0	0.002 (0.05)	10	10
3/32 to 3/16 (2.4 to 4.8), excl	0.003 (0.08)	0	0	0.003 (0.08)	10	10
3/16 to 1/2 (4.8 to 12.7), excl	0.004 (0.10)	0	0	0.004 (0.10)	10	10
1/2 to 1 1/4 (12.7 to 31.8), incl	0.005 (0.13)	0	0	0.005 (0.13)	10	10

<sup>A</sup>Ovality, Tube with Specified Wall Thickness >3 % of the Specified Outside Diameter—As-Drawn (No. 2 and 3) Tempers—Ovality will be held within the outside diameter tolerances shown in the table.

Annealed (No. 1) Temper—Ovality will be held within 2 % of the theoretical average outside diameter.

<sup>B</sup>Ovality, Tube with Specified Wall Thickness ≤3 % of the Specified Outside Diameter—As-Drawn (No. 2 and 3) Tempers—Up to but not including 1 1/4 in. (31.8 mm) in outside diameter, ovality will be held within 2 % of the theoretical average outside diameter.

Annealed (No. 1) Temper—Ovality will be held within 3 % of the theoretical average outside diameter.

<sup>C</sup>Wall Tolerances, Tube with Specified Wall Thickness ≤3 % of the Specified Outside Diameter—The plus and minus wall tolerance shown in the table shall apply down to and including 0.005 in. (0.13 mm) in wall thickness. For wall thicknesses less than 0.005 in. (0.13 mm), the tolerance shall be ± 0.005 in. (0.013 mm).

<sup>D</sup>Random Lengths:

Where nominal random lengths on tubing 1/8 in. (3.2 mm) and larger in outside diameter are specified, a length of ± 3 1/2 ft (1.06 m) applies to the nominal length. This is a total spread of 7 ft (2.10 m).

Random lengths in sizes 1/8 in. (3.2 mm) and larger in outside diameter shall be subject to a length range of 5 to 24 ft (1.50 to 7.30 m). Long random lengths are subject to a range of 15 to 22 ft (4.57 to 6.70 m).

Random lengths in sizes up to but not including 1/8 in. (3.2 mm) in outside diameter, and fragile tubes with specified wall thickness ≤3 % of the specified outside diameter over this outside diameter are subject to the length range of 1 to 15 ft (0.30 to 4.57 m).

<sup>E</sup>Cut Lengths—Tolerances on cut lengths shall be in accordance with Table X1.3.

<sup>F</sup>Straightness—Round tubing is subject to a straightness tolerance of one part in 600 [equivalent to a depth of arc of 0.030 in. (0.76 mm) in any 3 ft (0.91 m) of length].

<sup>G</sup>When specified, the tolerance spreads of this table may be applied as desired. However, when not specified, the tolerances in this table will apply. It should be noted that inside diameter tolerances are based upon the outside diameter range.

**TABLE X1.3 Tolerances on Cut Lengths of Tube with Specified Wall Thickness ≤3 % of the Specified Outside Diameter**

Length, ft (m)	Tube Size, in. (mm)	Permissible Variations, in. (mm)	
		Over	Under
Under 1 (0.30)	up to 1.250 (31.8), incl	1/32 (0.8)	0 (0)
1 to 4 (0.30 to 1.22), incl	up to 1.250 (31.8), incl	1/16 (1.6)	0 (0)
Over 4 to 10 (1.22 to 3.0), incl	up to 1.250 (31.8), incl	3/32 (2.4)	0 (0)
Over 10 (3.0)	up to 1.250 (31.8), incl	3/16 (4.8)	0 (0)

**X2. PIPE SCHEDULES**

X2.1 The schedules of pipe shown in Table X2.1 are regularly available. Other schedules may be furnished, and the manufacturer should be consulted. Table X2.1 is published for information only.

**TABLE X2.1 Pipe Schedules<sup>A</sup>**

Nominal Pipe Size, in.	Outside Diameter	Nominal Wall Thickness, in. (mm)			
		Schedule No. 5	Schedule No. 10	Schedule No. 40	Schedule No. 80
1/4	0.540(13.7)	...	0.065 (1.6)	0.088 (2.2)	...
3/8	0.675(17.1)	...	0.065 (1.6)	0.091 (2.3)	0.126 (3.2)
1/2	0.840(21.3)	0.065 (1.6)	0.083 (2.1)	0.109 (2.8)	0.147 (3.7)
3/4	1.050(26.7)	0.065 (1.6)	0.083 (2.1)	0.113 (2.8)	0.154 (3.9)
1	1.315(33.4)	0.065 (1.6)	0.109 (2.8)	0.133 (3.4)	0.179 (4.5)
1 1/4	1.660(42.2)	0.065 (1.6)	0.109 (2.8)	0.140 (3.6)	0.191 (4.8)
1 1/2	1.900(48.3)	0.065 (1.6)	0.109 (2.8)	0.145 (3.7)	0.200 (5.1)
2	2.375(60.3)	0.065 (1.6)	0.109 (2.8)	0.154 (3.9)	0.218 (5.5)
2 1/2	2.875(73.0)	0.083 (2.1)	0.120 (3.0)	0.203 (5.2)	0.276 (7.0)
3	3.500(88.9)	0.083 (2.1)	0.120 (3.0)	0.216 (5.5)	0.300 (7.6)
3 1/2	4.000(101.6)	0.083 (2.1)	0.120 (3.0)	0.226 (5.7)	0.318 (8.1)
4	4.500(114.3)	0.083 (2.1)	0.120 (3.0)	0.237 (6.0)	0.337 (8.6)
5	5.563(141.3)	...	...	0.258 (6.5)	...
6	6.625(168.3)	...	...	0.280 (7.1)	...

<sup>A</sup> The pipe schedules shown above conform with standards adopted by the American National Standards Institute.

### X3. CONDITIONS AND FINISHES NORMALLY SUPPLIED

#### X3.1 Scope

X3.1.1 This appendix lists the conditions and finishes in which pipe and tube (other than converter sizes) are normally supplied. These are subject to change, and the manufacturer should be consulted for the latest information available.

#### X3.2 Cold-Worked Tube and Pipe

X3.2.1 *Cold-Worked, Annealed, with Ground Outside Diameter*—The inside diameter may have a bright finish when material is annealed in a protective atmosphere; otherwise, the inside diameter is supplied descaled as necessary. It is available in sizes ½ to 4 in. (12.7 to 102 mm), inclusive, in outside diameter in both normal and heavy-wall tube, and pipe sizes, all schedules, of corresponding outside-diameter dimensions.

X3.2.2 *Cold-Worked, Annealed, and Pickled (Not Ground)*—Outside and inside diameter will have dull, matte (pickled) surfaces. It is available in sizes ½ to 6⅝ in. (12.7 to 168 mm), inclusive, in outside diameter in both normal and

heavy-wall tube, and pipe sizes, all schedules, of corresponding outside-diameter dimensions.

#### X3.3 Hot-Worked Tube

X3.3.1 *Hot-Worked or Hot-Worked-Annealed (Not Pickled) Tube*—Has an oxide surface resulting from the hot-working operation. Intended generally for machined parts where the oxide surface will be removed.

X3.3.2 *Hot-Worked or Hot-Worked-Annealed (Pickled) Tube*—Has the oxide surface removed on both outside and inside diameters by pickling. Surface may be spot ground for removal of minor surface imperfections at the manufacturer's option.

X3.3.3 *Hot-Worked or Hot-Worked-Annealed (Machined Outside and Inside Diameters) Tubes*—The outside and inside diameter surfaces are machined to specified dimensions. Minor surface imperfections may be spot ground for removal, at the manufacturer's option.

ASME BPVC Section II Part B) 2025  
Click to view the full PDF of ASME BPVC.II.B (ASME BPVC Section II Part B) 2025

**SPECIFICATION FOR NICKEL-CHROMIUM-ALUMINUM ALLOYS (UNS N06699), NICKEL-CHROMIUM-IRON ALLOYS (UNS N06600, N06601, N06603, N06690, N06693, N06025, N06045, AND N06696), NICKEL-CHROMIUM-COBALT-MOLYBDENUM ALLOY (UNS N06617), NICKEL-IRON-CHROMIUM-TUNGSTEN ALLOY (UNS N06674), AND NICKEL-CHROMIUM-MOLYBDENUM-COPPER ALLOY (UNS N06235) PLATE, SHEET, AND STRIP**



SB-168

(25)

(Identical with ASTM Specification B168-19 except for the deletion of Footnote A in Table 3 and addition of N06617 heat treatment requirements. Certification and test reports have been made mandatory.)

# Specification for Nickel-Chromium-Aluminum Alloys (UNS N06699), Nickel- Chromium-Iron Alloys (UNS N06600, N06601, N06603, N06690, N06693, N06025, N06045, and N06696), Nickel- Chromium-Cobalt-Molybdenum Alloy (UNS N06617), Nickel- Iron-Chromium-Tungsten Alloy (UNS N06674), and Nickel- Chromium-Molybdenum-Copper Alloy (UNS N06235) Plate, Sheet, and Strip

## 1. Scope

1.1 This specification covers rolled nickel-chromium-aluminum alloys (UNS N06699), nickel-chromium-iron alloys (UNS N06600, N06601, N06603, N06690, N06693, N06025, N06045, and N06696), nickel-chromium-cobalt-molybdenum alloy (UNS N06617), nickel-iron-chromium-tungsten alloy (UNS N06674), and nickel-chromium-molybdenum-copper alloy (UNS N06235) plate, sheet, and strip.

1.2 The values stated in inch-pound units are to be regarded as standard. The values given in parentheses are mathematical conversions to SI units that are provided for information only and are not considered standard.

1.3 The following precautionary caveat pertains only to the test methods portion, Section 13, of this specification: *This standard does not purport to address all of the safety concerns, if any, associated with its use. It is the responsibility of the user of this standard to become familiar with all hazards including those identified in the appropriate Safety Data Sheet (SDS) for this product/material as provided by the manufacturer, to establish appropriate safety, health, and environmental practices, and determine the applicability of regulatory limitations prior to use.*

1.4 *This international standard was developed in accordance with internationally recognized principles on standard-*

*ization established in the Decision on Principles for the Development of International Standards, Guides and Recommendations issued by the World Trade Organization Technical Barriers to Trade (TBT) Committee.*

## 2. Referenced Documents

### 2.1 ASTM Standards:

- B166 Specification for Nickel-Chromium-Aluminum Alloy, Nickel-Chromium-Iron Alloys, Nickel-Chromium-Cobalt-Molybdenum Alloy, Nickel-Iron-Chromium-Tungsten Alloy, and Nickel-Chromium-Molybdenum-Copper Alloy Rod, Bar, and Wire
- B880 Specification for General Requirements for Chemical Check Analysis Limits for Nickel, Nickel Alloys and Cobalt Alloys
- E8/E8M Test Methods for Tension Testing of Metallic Materials
- E10 Test Method for Brinell Hardness of Metallic Materials
- E18 Test Methods for Rockwell Hardness of Metallic Materials
- E29 Practice for Using Significant Digits in Test Data to Determine Conformance with Specifications
- E38 Methods for Chemical Analysis of Nickel-Chromium and Nickel-Chromium-Iron Alloys (Withdrawn 1989)
- E112 Test Methods for Determining Average Grain Size
- E140 Hardness Conversion Tables for Metals Relationship Among Brinell Hardness, Vickers Hardness, Rockwell

Hardness, Superficial Hardness, Knoop Hardness, Scleroscope Hardness, and Leeb Hardness

E527 Practice for Numbering Metals and Alloys in the Unified Numbering System (UNS)

E1473 Test Methods for Chemical Analysis of Nickel, Cobalt and High-Temperature Alloys

F155 Method of Test for Temper of Strip and Sheet Metals for Electronic Devices (Spring-Back Method) (Withdrawn 1982)

#### 2.2 Federal Standards:

Fed. Std. No. 102 Preservation, Packaging and Packing Levels

Fed. Std. No. 123 Marking for Shipment (Civil Agencies)

Fed. Std. No. 182 Continuous Identification Marking of Nickel and Nickel-Base Alloys

#### 2.3 Military Standard:

MIL-STD-129 Marking for Shipment and Storage

### 3. Terminology

3.1 *Descriptions of Terms Specific to This Standard*—The terms given in Table 1 shall apply.

### 4. Ordering Information

4.1 It is the responsibility of the purchaser to specify all requirements that are necessary for the safe and satisfactory performance of material ordered under this specification. Examples of such requirements include, but are not limited to, the following:

4.1.1 *Alloy*—Name or UNS number (see Table 2),

4.1.2 *ASTM designation*, including year of issue,

4.1.3 *Condition*—See 7.1 and 7.2 and Appendix X1,

4.1.4 *Finish*—Appendix X1,

4.1.5 *Dimensions*—Thickness, width, and length,

4.1.6 *Quantity*,

4.1.7 *Optional Requirements*:

4.1.7.1 *Sheet and Strip*—Whether to be furnished in coil, in cut straight lengths, or in random straight lengths,

4.1.7.2 *Strip*—Whether to be furnished with commercial slit edge, square edge, or round edge,

4.1.7.3 *Plate*—Whether to be furnished specially flattened (see 8.7.2); also how plate is to be cut (see 8.2.1 and 8.3.2),

4.1.8 DELETED

4.1.9 *Samples for Product (Check) Analysis*—Whether samples for product (check) analysis should be furnished (see 5.2), and

4.1.10 *Purchaser Inspection*—If the purchaser wishes to witness tests or inspection of material at the place of manufacture, the purchase order must so state indicating which tests or inspections are to be witnessed (Section 14).

### 5. Chemical Composition

5.1 The material shall conform to the requirements as to chemical composition prescribed in Table 2.

5.2 If a product (check) analysis is performed by the purchaser, the material shall conform to the product (check) analysis variations prescribed in Specification B880.

### 6. Heat Treatment

6.1 Material of N06674 shall be solution annealed after cold-working or hot-working by heating to 2150°F (1175°C) minimum, followed by quenching in water or rapidly cooling by other means.

### 7. Mechanical Properties and Other Requirements

7.1 *Mechanical Properties*—The material shall conform to the mechanical properties prescribed in Table 3.

7.2 *Deep Drawing and Spinning Quality Sheet and Strip*—The material shall conform to the grain size and hardness requirements as prescribed in Table 4.

7.2.1 The mechanical properties of Table 3 do not apply to deep drawing and spinning quality sheet and strip.

7.3 *Grain Size*—Except as prescribed in 7.2, the grain size for N06674 shall be 7 or coarser, as determined in accordance with Test Methods E112.

### 8. Dimensions and Permissible Variations

#### 8.1 Thickness and Weight:

8.1.1 *Plate*—For plate up to 2 in. (50.8 mm), inclusive, in thickness, the permissible variation under the specified thickness and permissible excess in overweight shall not exceed the amounts prescribed in Table 5.

8.1.1.1 For use with Table 5, plate shall be assumed to weigh 0.304 lb/in.<sup>3</sup> (8.415 g/cm<sup>3</sup>).

8.1.2 *Plate*—For plate over 2 in. (50.8 mm) in thickness, the permissible variations over the specified thickness shall not exceed the amounts prescribed in Table 6.

8.1.3 *Sheet and Strip*—The permissible variations in thickness of sheet and strip shall be as prescribed in Table 7. The

TABLE 1 Product Description

Product	Thickness, in. (mm)	Width, in. (mm)
Hot-rolled plate <sup>A</sup>	3/16 and over (Table 5 and Table 6)	(Table 8) <sup>B</sup>
Hot-rolled sheet <sup>A</sup>	0.018 to 0.250 (0.46 to 6.4), incl (Table 7)	(Table 10)
Cold-rolled sheet <sup>C</sup>	0.018 to 0.250 (0.46 to 6.4), incl (Table 7)	(Table 10)
Cold-rolled strip <sup>C</sup>	0.005 to 0.250 (0.13 to 6.4), incl (Table 7)	(Table 10)

<sup>A</sup> Material 3/16 to 1/4 in. (4.8 to 6.4 mm), incl, in thickness may be furnished as sheet or plate provided the material meets the specification requirements for the condition ordered.

<sup>B</sup> Hot-rolled plate, in widths 10 in. (254 mm) and under, may be furnished as hot-finished rectangles with sheared or cut edges in accordance with Specification B166, provided the mechanical property requirements of this specification are met.

<sup>C</sup> Material under 48 in. (1219 mm) in width may be furnished as sheet or strip provided the material meets the specification requirements for the condition ordered.

TABLE 2 Chemical Requirements<sup>A</sup>

Element	Composition Limits, %											
	Alloy N06600	Alloy N06601	Alloy N06617	Alloy N06674	Alloy N06690	Alloy N06693	Alloy N06025	Alloy N06045	Alloy N06603	Alloy N06696	Alloy N06235	Alloy N06699
Nickel	72.0 min	58.0–63.0	44.5 min	remainder <sup>B</sup>	58.0 min	remainder <sup>B</sup>	remainder <sup>B</sup>	45.0 min	remainder <sup>B</sup>	remainder <sup>B</sup>	remainder <sup>B</sup>	remainder <sup>B</sup>
Chromium	14.0–17.0	21.0–25.0	20.0–24.0	21.5–24.5	27.0–31.0	27.0–31.0	24.0–26.0	26.0–29.0	24.0–26.0	28.0–32.0	30.0–32.5	26.0–30.0
Cobalt	...	...	10.0–15.0	...	...	...	...	...	...	...	1.0 max	...
Molybdenum	...	...	8.0–10.0	...	...	...	...	...	...	1.0–3.0	5.0–6.2	...
Niobium	...	...	...	0.10–0.35	...	0.5–2.5	...	...	...	...	1.0 max	0.50 max
Iron	6.0–10.0	remainder <sup>B</sup>	3.0 max	20.0–27.0	7.0–11.0	2.5–6.0	8.0–11.0	21.0–25.0	8.0–11.0	2.0–6.0	1.5 max	2.5 max
Manganese	1.0 max	1.0 max	1.0 max	1.50 max	0.5 max	1.0 max	0.15 max	1.0 max	0.15 max	1.0 max	0.3–0.65	0.50 max
Aluminum	...	1.0–1.7	0.8–1.5	...	...	2.5–4.0	1.8–2.4	...	2.4–3.0	...	0.2–0.4	1.9–3.0
Carbon	0.15 max	0.10 max	0.05–0.15	0.10 max	0.05 max	0.15 max	0.15–0.25	0.05–0.12	0.20–0.40	0.15 max	0.02–0.06	0.005–0.10
Copper	0.5 max	1.0 max	0.5 max	...	0.5 max	0.5 max	0.1 max	0.3 max	0.50 max	1.5–3.0	3.5–4.0	0.50 max
Silicon	0.5 max	0.5 max	1.0 max	1.0 max	0.5 max	0.5 max	0.5 max	2.5–3.0	0.50 max	1.0–2.5	0.2–0.6	0.50 max
Sulfur	0.015 max	0.015 max	0.015 max	0.015 max	0.015 max	0.01 max	0.010 max	0.010 max	0.010 max	0.010 max	0.015 max	0.01 max
Titanium	...	...	0.6 max	0.05–0.20	...	1.0 max	0.1–0.2	...	0.01–0.25	1.0 max	0.5 max	0.60 max
Phosphorus	...	...	...	0.030 max	...	...	0.020 max	0.020 max	0.020 max	...	0.03 max	0.02 max
Zirconium	...	...	...	...	...	...	0.01–0.10	...	0.01–0.10	...	...	0.10 max
Yttrium	...	...	...	...	...	...	0.05–0.12	...	0.01–0.15	...	...	...
Boron	...	...	0.006 max	0.0005–0.006	...	...	...	...	...	...	...	0.008 max
Nitrogen	...	...	...	0.02 max	...	...	...	...	...	...	...	0.05 max
Cerium	...	...	...	...	...	...	...	0.03–0.09	...	...	...	...
Tungsten	...	...	...	6.0–8.0	...	...	...	...	...	...	0.60 max	...

<sup>A</sup> Where ellipses (...) appear in this table there is no requirement and the element need neither be analyzed for nor reported.

<sup>B</sup> Element shall be determined arithmetically by difference.

ASME NORMDOC.COM : Click to view the full PDF of ASME BPVC.II.B (ASME BPVC Section II part B) 2025

TABLE 3 Mechanical Properties for Plate, Sheet, and Strip (All Thicknesses and Sizes Unless Otherwise Indicated)

Condition (Temper)	Tensile Strength, min, psi (MPa)	Yield Strength <sup>A</sup> (0.2 % offset), min, psi (MPa)	Elongation in 2 in. or 50 mm (or 4D), min,%	Rockwell Hardness <sup>B,C</sup>
Hot-Rolled Plate				
UNS N06600:				
Annealed	80 000 (550)	35 000 (240)	30	...
As-rolled <sup>D,E</sup>	85 000 (586)	35 000 (240)	30	...
UNS N06601:				
Annealed	80 000 (550)	30 000 (205)	30	...
UNS N06603:				
Annealed	94 000 (650)	43 000 (300)	25	...
UNS N06617:				
Annealed <sup>H</sup>	95 000 (655)	35 000 (240)	35	...
UNS N06674:				
Annealed	86 000 (590)	34 000 (235)	30	...
UNS N06690:				
Annealed	85 000 (586)	35 000 (240)	30	...
As-rolled <sup>D,E</sup>	85 000 (586)	35 000 (240)	30	...
Annealed <sup>F</sup>	75 000 (514)	30 000 (206)	30	...
UNS N06693:				
Annealed	100 000 (690)	50 000 (345)	30	...
UNS N06025:				
Annealed	98 000 (680)	39 000 (270)	30	...
UNS N06045:				
Annealed	90 000 (620)	35 000 (240)	35	...
UNS N06235:				
Annealed	90 000 (620)	35 000 (240)	35	...
UNS N06699:				
Annealed	89 000 (610)	35 000 (240)	40	...
Hot-Rolled Sheet				
UNS N06600:				
Annealed	80 000 (550)	35 000 (240)	30	...
UNS N06601:				
Annealed	80 000 (550)	30 000 (205)	30	...
UNS N06603:				
Annealed	94 000 (650)	43 000 (300)	25	...
UNS N06617:				
Annealed <sup>H</sup>	95 000 (655)	35 000 (240)	30	...
UNS N06674:				
Annealed	86 000 (590)	34 000 (235)	30	...
UNS N06690:				
Annealed	85 000 (586)	35 000 (240)	30	...
UNS N06693:				
Annealed	100 000 (690)	50 000 (345)	30	...
UNS N06025:				
Annealed	98 000 (680)	39 000 (270)	30	...
UNS N06045:				
Annealed	90 000 (620)	35 000 (240)	35	...
UNS N06235:				
Annealed	90 000 (620)	35 000 (240)	35	...
UNS N06699:				
Annealed	89 000 (610)	35 000 (240)	40	...
Cold-Rolled Plate				
UNS N06603:				
Annealed	94 000 (650)	43 000 (300)	25	...
UNS N06674:				
Annealed	86 000 (590)	34 000 (235)	30	...
UNS N06025:				
Annealed	98 000 (680)	39 000 (270)	30	...
UNS N06045:				
Annealed	90 000 (620)	35 000 (240)	35	...
UNS N06235:				
Annealed	90 000 (620)	35 000 (240)	35	...
UNS N06699:				
Annealed	89 000 (610)	35 000 (240)	40	...
Cold-Rolled Sheet				
UNS N06600:				
Annealed	80 000 (550) <sup>G</sup>	35 000 (240)	30 <sup>G</sup>	...
Hard	125 000 (860) <sup>G</sup>	90 000 (620)	2 <sup>G</sup>	...
UNS N06601:				
Annealed	80 000 (550) <sup>G</sup>	30 000 (205)	30 <sup>G</sup>	...
UNS N06603:				
Annealed	94 000 (650)	43 000 (300)	25 <sup>G</sup>	...
UNS N06674:				
Annealed	86 000 (590)	34 000 (235)	30	...
UNS N06617:				

TABLE 3 Continued

Condition (Temper)	Tensile Strength, min, psi (MPa)	Yield Strength <sup>A</sup> (0.2 % offset), min, psi (MPa)	Elongation in 2 in. or 50 mm (or 4D), min,%	Rockwell Hardness <sup>B,C</sup>
Annealed <sup>H</sup>	95 000 (655) <sup>G</sup>	35 000 (240)	25 <sup>G</sup>	...
UNS N06690:				
Annealed	85 000 (586) <sup>G</sup>	35 000 (240)	30 <sup>G</sup>	...
Hard	125 000 (860) <sup>G</sup>	90 000 (620)	2 <sup>G</sup>	...
UNS N06693:				
Annealed	100 000 (690)	50 000 (345)	30	...
UNS N06025:				
Annealed	98 000 (680)	39 000 (270)	30	...
UNS N06045:				
Annealed	90 000 (620)	35 000 (240)	35	...
UNS N06235:				
Annealed	90 000 (620)	35 000 (240)	35	...
UNS N06699:				
Annealed	89 000 (610)	35 000 (240)	40	...
Cold-Rolled Strip				
UNS N06600:				
Annealed	80 000 (550) <sup>G</sup>	35 000 (240)	30 <sup>G</sup>	...
Skin-hard	...	...	...	B85 to B88
Quarter-hard	...	...	...	B88 to B94
Half-hard	...	...	...	B93 to B98
Three-quarter-hard	...	...	...	B97 to C25
Hard	125 000 (860) <sup>G</sup>	90 000 (620)	2 <sup>G</sup>	...
Spring	...	...	...	C30 min
UNS N06601:				
Annealed	80 000 (550) <sup>G</sup>	30 000 (205)	30 <sup>G</sup>	...
UNS N06603:				
Annealed	94 000 (650)	43 000 (300)	25 <sup>G</sup>	...
UNS N06617:				
Annealed <sup>H</sup>	95 000 (655) <sup>G</sup>	35 000 (240)	30 <sup>G</sup>	...
UNS N06674:				
Annealed	86 000 (590)	34 000 (235)	30	...
UNS N06690:				
Annealed	85 000 (586) <sup>G</sup>	35 000 (240)	30 <sup>G</sup>	...
Skin-hard	...	...	...	B85 to B88
Quarter-hard	...	...	...	B88 to B94
Half-hard	...	...	...	B93 to B98
Three-quarter-hard	...	...	...	B97 to C25
Hard	125 000 (860) <sup>G</sup>	90 000 (620)	2 <sup>G</sup>	...
Spring	...	...	...	C30 min
UNS N06693:				
Annealed	100 000 (690)	50 000 (345)	30	...
UNS N06025:				
Annealed	98 000 (680)	39 000 (270)	30	...
UNS N06045:				
Annealed	90 000 (620)	35 000 (240)	35	...
UNS N06696:				
Annealed	85 000 (586)	35 000 (240)	30	...
UNS N06235:				
Annealed	90 000 (620)	35 000 (240)	35	...
UNS N06699:				
Annealed	89 000 (610)	35 000 (210)	40	...

<sup>A</sup> DELETED<sup>B</sup> For Rockwell or equivalent hardness conversions, see Hardness Conversion Tables E140.<sup>C</sup> Caution should be served in using the Rockwell test on thin material, as the results may be affected by specimen thickness. For thicknesses under 0.050 in. (1.3 mm), the use of the Rockwell superficial or the Vickers hardness test is suggested.<sup>D</sup> As-rolled plate may be given a stress relieving heat treatment subsequent to final rolling.<sup>E</sup> As-rolled plate specified "suitable for hot forming" shall be furnished from heats of known good hot-malleability characteristics (see X1.2.2). There are no applicable tensile or hardness requirements for such material.<sup>F</sup> Annealed at 1850°F (1010°C) minimum.<sup>G</sup> Not applicable for thickness under 0.010 in. (0.25 mm).<sup>H</sup> Solution anneal is done at 2,100°F to 2,250°F and quenched in water or rapidly cooled by other means.

thickness of strip and sheet shall be measured with the micrometer spindle  $\frac{3}{8}$  in. (9.5 mm) or more from either edge for material 1 in. (25.4 mm) or over in width and at any place on the strip under 1 in. in width.

## 8.2 Width or Diameter:

8.2.1 *Plate*—The permissible variations in width of rectangular plates and diameter of circular plates shall be as prescribed in Table 8 and Table 9.

8.2.2 *Sheet and Strip*—The permissible variations in width for sheet and strip shall be as prescribed in Table 10.

## 8.3 Length:

8.3.1 Sheet and strip of all sizes may be ordered to cut lengths, in which case a variation of  $\frac{1}{8}$  in. (3.2 mm) over the specified length shall be permitted.

8.3.2 Permissible variations in length of rectangular plate shall be as prescribed in Table 11.

**TABLE 4 Grain Size and Hardness for Cold-Rolled, Deep-Drawing, and Spinning-Quality Sheet and Strip**

Thickness, in. (mm)	Calculated Diameter of Average Grain Section, max, in. (mm)	Corresponding ASTM MicroGrain Size No.	Rockwell B <sup>A,B</sup> Hardness, max
Sheet (56 in. (1.42 m) Wide and Under)			
0.050 (1.3) and less	0.0030 (0.075)	4.5	86
Over 0.050 to 0.250 (1.3 to 6.4), incl	0.0043 (0.110)	3.5	86
Strip (12 in. (305 mm) Wide and Under) <sup>C</sup>			
0.005 <sup>D</sup> to 0.010 (0.13 to 0.25), incl	0.0009 (0.022)	8 <sup>E</sup>	88 <sup>E</sup>
Over 0.010 to 0.125 (0.25 to 3.2), incl	0.0030 (0.075)	4.5	86

<sup>A</sup> For Rockwell or equivalent hardness conversions, see Hardness Conversion Tables E140.

<sup>B</sup> Caution should be observed in using the Rockwell test on thin material, as the results may be affected by specimen thickness. For thicknesses under 0.050 in. (1.3 mm), the use of the Rockwell superficial or the Vickers hardness test is suggested.

<sup>C</sup> Sheet requirements (above) apply to strip thicknesses over 0.125 in. (3.2 mm) and for all thicknesses of strip over 12 in. (305 mm) in width.

<sup>D</sup> For ductility evaluations for strip under 0.005 in. (0.13 mm) in thickness, the springback test, such as described in Test Method F155, is often used and the manufacturer should be consulted.

<sup>E</sup> Accurate grain size and hardness determinations are difficult to make on strip under 0.005 in. (0.13 mm) in thickness and are not recommended.

**TABLE 5 Permissible Variations in Thickness and Overweight of Rectangular Plates**

NOTE 1—All plates shall be ordered to thickness and not to weight per square foot (cm). No plates shall vary more than 0.01 in. (0.3 mm) under the thickness ordered, and the overweight of each lot<sup>A</sup> in each shipment shall not exceed the amount in the table. Spot grinding is permitted to remove surface imperfections, such spots not to exceed 0.01 in. under the specified thickness.

Specified Thickness, in. (mm)	Permissible Excess in Average Weight <sup>B,C</sup> per Square Foot of Plates for Widths Given in Inches (Millimetres) Expressed in Percentage of Nominal Weights									
	Under 48 (1220)	48 to 60 (1220 to 1520), excl	60 to 72 (1520 to 1830), excl	72 to 84 (1830 to 2130), excl	84 to 96 (2130 to 2440), excl	96 to 108 (2440 to 2740), excl	108 to 120 (2740 to 3050), excl	120 to 132 (3050 to 3350), excl	132 to 144 (3350 to 3660), excl	144 to 160 (3660 to 4070), excl
3/16 to 5/16 (4.8 to 7.9), excl	9.0	10.5	12.0	13.5	15.0	16.5	18.0	...	...	...
5/16 to 3/8 (7.9 to 9.5), excl	7.5	9.0	10.5	12.0	13.5	15.0	16.5	18.0	...	...
3/8 to 7/16 (9.5 to 11.1), excl	7.0	7.5	9.0	10.5	12.0	13.5	15.0	16.5	18.0	19.5
7/16 to 1/2 (11.1 to 12.7), excl	6.0	7.0	7.5	9.0	10.5	12.0	13.5	15.0	16.5	18.0
1/2 to 5/8 (12.7 to 15.9), excl	5.0	6.0	7.0	7.5	9.0	10.5	12.0	13.5	15.0	16.5
5/8 to 3/4 (15.9 to 19.1), excl	4.5	5.5	6.0	7.0	7.5	9.0	10.5	12.0	13.5	15.0
3/4 to 1 (19.1 to 25.4), excl	4.0	4.5	5.5	6.0	7.0	7.5	9.0	10.5	12.0	13.5
1 to 2 (25.4 to 50.8), incl	4.0	4.0	4.5	5.5	6.0	7.0	7.5	9.0	10.5	12.0

<sup>A</sup> The term "lot" applied to this table means all of the plates of each group width and each group thickness.

<sup>B</sup> The permissible overweight for lots of circular and sketch plates shall be 25 % greater than the amounts given in this table.

<sup>C</sup> The weight of individual plates shall not exceed the nominal weight by more than 1/4 times the amount given in the table and Footnote B.

8.4 Straightness:

8.4.1 The edgewise curvature (depth of chord) of flat sheet, strip, and plate shall not exceed 0.05 in. multiplied by the length in feet (0.04 mm multiplied by the length in centimetres).

8.4.2 Straightness for coiled material is subject to agreement between the manufacturer and the purchaser.

8.5 Edges:

8.5.1 When finished edges of strip are specified in the contract or order, the following descriptions shall apply:

8.5.1.1 Square-edge strip shall be supplied with finished edges, with sharp, square corners, without bevel or rounding.

8.5.1.2 Round-edge strip shall be supplied with finished edges, semicircular in form, the diameter of the circle forming the edge being equal to the strip thickness.

**TABLE 6 Permissible Variations in Thickness for Rectangular Plates Over 2 in. (51 mm) in Thickness**

NOTE 1—Permissible variation under specified thickness, 0.01 in. (0.3 mm).

Specified Thickness, in. (mm)	Permissible Variations, in. (mm), over Specified Thickness for Widths Given, in. (mm)					
	To 36 (915), excl	36 to 60 (915 to 1520), excl	60 to 84 (1520 to 2130), excl	84 to 120 (2130 to 3050), excl	120 to 132 (3050 to 3350), excl	132 (3350) and over
Over 2 to 3 (51 to 76), excl	1/16 (1.6)	3/32 (2.4)	7/64 (2.8)	1/8 (3.2)	1/8 (3.2)	9/64 (3.6)
3 to 4 (76 to 102), incl	5/64 (2.0)	3/32 (2.4)	7/64 (2.8)	1/8 (3.2)	1/8 (3.2)	9/64 (3.6)

**TABLE 7 Permissible Variations in Thickness of Sheet and Strip  
(Permissible Variations, Plus and Minus, in Thickness, in. (mm), for Widths Given in in. (mm))**

Specified Thickness, in. (mm)	Sheet <sup>A</sup>			
	Hot-Rolled		Cold-Rolled	
	48 (1220) and Under	Over 48 to 60 (1220 to 1520), incl	48 (1220) and Under	Over 48 to 60 (1220 to 1520), incl
0.018 to 0.025 (0.5 to 0.6), incl	0.003 (0.08)	0.004 (0.10)	0.002 (0.05)	0.003 (0.08)
Over 0.025 to 0.034 (0.6 to 0.9), incl	0.004 (0.10)	0.005 (0.13)	0.003 (0.08)	0.004 (0.10)
Over 0.034 to 0.043 (0.9 to 1.1), incl	0.005 (0.13)	0.006 (0.15)	0.004 (0.10)	0.005 (0.13)
Over 0.043 to 0.056 (1.1 to 1.4), incl	0.005 (0.13)	0.006 (0.15)	0.004 (0.10)	0.005 (0.13)
Over 0.056 to 0.070 (1.4 to 1.8), incl	0.006 (0.15)	0.007 (0.18)	0.005 (0.13)	0.006 (0.15)
Over 0.070 to 0.078 (1.8 to 1.9), incl	0.007 (0.18)	0.008 (0.20)	0.006 (0.15)	0.007 (0.18)
Over 0.078 to 0.093 (1.9 to 2.4), incl	0.008 (0.20)	0.009 (0.23)	0.007 (0.18)	0.008 (0.20)
Over 0.093 to 0.109 (2.4 to 2.8), incl	0.009 (0.23)	0.010 (0.25)	0.007 (0.18)	0.009 (0.23)
Over 0.109 to 0.125 (2.8 to 3.2), incl	0.010 (0.25)	0.012 (0.31)	0.008 (0.20)	0.010 (0.25)
Over 0.125 to 0.140 (3.2 to 3.6), incl	0.012 (0.31)	0.014 (0.36)	0.008 (0.20)	0.010 (0.25)
Over 0.140 to 0.171 (3.6 to 4.3), incl	0.014 (0.36)	0.016 (0.41)	0.009 (0.23)	0.012 (0.31)
Over 0.171 to 0.187 (4.3 to 4.8), incl	0.015 (0.38)	0.017 (0.43)	0.010 (0.25)	0.013 (0.33)
Over 0.187 to 0.218 (4.8 to 5.5), incl	0.017 (0.43)	0.019 (0.48)	0.011 (0.28)	0.015 (0.38)
Over 0.218 to 0.234 (5.5 to 5.9), incl	0.018 (0.46)	0.020 (0.51)	0.012 (0.31)	0.016 (0.41)
Over 0.234 to 0.250 (5.9 to 6.4), incl	0.020 (0.51)	0.022 (0.56)	0.013 (0.33)	0.018 (0.46)
	Cold-Rolled Strip <sup>A,B</sup>			
Specified Thickness, in. (mm)	Widths 12 in. (305 mm) and under, plus and minus			
Up to 0.050 (1.27), incl				0.0015 (0.038)
Over 0.050 to 0.093 (1.27 to 2.39), incl				0.0025 (0.063)
Over 0.093 to 0.125 (2.39 to 3.18), incl				0.004 (0.11)

<sup>A</sup> Measured 3/8 in. (9.5 mm) or more from either edge except for strip under 1 in. (25.4 mm) in width which is measured at any place.

<sup>B</sup> Standard sheet tolerances apply for thicknesses over 0.125 in. (3.2 mm) and for all thicknesses of strip over 12 in. (305 mm) wide.

8.5.1.3 When no description of any required form of strip edge is given, it shall be understood that edges such as those resulting from slitting or shearing will be acceptable.

8.5.1.4 Sheet shall have sheared or slit edges.

8.5.1.5 Plate shall have sheared or cut (machined, abrasive-cut, powder-cut, or inert-arc cut) edges, as specified.

8.6 *Squareness (Sheet)*—For sheets of all thicknesses, the angle between adjacent sides shall be 90 ± 0.15° (1/16 in. in 24 in. (1.6 mm in 610 mm)).

8.7 *Flatness:*

8.7.1 There shall be no flatness requirements for “deep-drawing quality,” “spinning quality,” or “as rolled” sheet and strip (see X1.4).

8.7.2 Standard flatness tolerances for plate shall conform to the requirements of Table 12. “Specially flattened” plate, when so specified, shall have permissible variations in flatness as agreed upon between the manufacturer and the purchaser.

**9. Workmanship, Finish, and Appearance**

9.1 The material shall be uniform in quality and temper, smooth, commercially straight or flat, and free of injurious imperfections.

9.2 *Sheet, Strip, and Plate*—Sheet, strip, and plate supplied in the conditions and finishes as listed in the appendix may be ground or machined to remove surface imperfections, provided such removal does not reduce the material below the minimum specified dimensions. Surface eliminated depressions shall be faired smoothly into the surrounding material. The removal of a surface imperfection shall be verified by the method originally used to detect the imperfection.

**10. Sampling**

10.1 *Lot*—Definition:

10.1.1 A lot for chemical analysis shall consist of one heat.

10.1.2 A lot for mechanical properties, hardness, and grain size testing shall consist of all material from the same heat, nominal thickness, and condition.

10.1.2.1 Where material cannot be identified by heat, a lot shall consist of not more than 500 lb (227 kg) of material in the same thickness and condition, except for plates weighing over 500 lb, in which case only one specimen shall be taken.

10.2 *Test Material Selection:*

TABLE 8 Permissible variations<sup>A</sup> of Sheared, Plasma-Torch-Cut, and Abrasive-Cut Rectangular Plate<sup>B,C</sup>

Specified Thickness	Permissible Variations in Widths for Widths Given, in. (mm)									
	Up to 30 (760), incl		Over 30 to 72 (760 to 1830), incl		Over 72 to 108 (1830 to 2740), incl		Over 108 to 144 (2740 to 3660), incl		Over 144 to 160 (3660 to 4070), incl	
	+	-	+	-	+	-	+	-	+	-
Inches										
Sheared: <sup>D</sup>										
3/16 to 5/16, excl	3/16	1/8	1/4	1/8	3/8	1/8	1/2	1/8	...	...
5/16 to 1/2, excl	1/4	1/8	3/8	1/8	3/8	1/8	1/2	1/8	5/8	1/8
1/2 to 3/4, excl	3/8	1/8	3/8	1/8	1/2	1/8	5/8	1/8	3/4	1/8
3/4 to 1, excl	1/2	1/8	1/2	1/8	5/8	1/8	3/4	1/8	7/8	1/8
1 to 1 1/4, incl	5/8	1/8	5/8	1/8	3/4	1/8	7/8	1/8	1	1/8
Abrasive cut: <sup>E,F</sup>										
3/16 to 1 1/4, incl	1/8	1/8	1/8	1/8	1/8	1/8	1/8	1/8	1/8	1/8
Over 1 1/4 to 2 3/4, incl	3/16	1/8	3/16	1/8	3/16	1/8	3/16	1/8	3/16	1/8
Plasma-torch-cut: <sup>G</sup>										
3/16 to 2, excl	1/2	0	1/2	0	1/2	0	1/2	0	1/2	0
2 to 3, incl	5/8	0	5/8	0	5/8	0	5/8	0	5/8	0
Millimetres										
Sheared: <sup>D</sup>										
4.8 to 7.9, excl	4.8	3.2	6.4	3.2	9.5	3.2	12.7	3.2	...	...
7.9 to 12.7, excl	6.4	3.2	9.5	3.2	9.5	3.2	12.7	3.2	15.9	3.2
12.7 to 19.1, excl	9.5	3.2	9.5	3.2	12.7	3.2	15.9	3.2	19.1	3.2
19.1 to 25.4, excl	12.7	3.2	12.7	3.2	15.8	3.2	19.1	3.2	22.2	3.2
25.4 to 31.8, incl	15.9	3.2	15.9	3.2	19.1	3.2	22.2	3.2	25.4	3.2
Abrasive cut: <sup>E,F</sup>										
4.8 to 31.8, incl	3.2	3.2	3.2	3.2	3.2	3.2	3.2	3.2	3.2	3.2
Over 31.8 to 69.8, incl	4.8	3.2	4.8	3.2	4.8	3.2	4.8	3.2	4.8	3.2
Plasma-torch-cut: <sup>G</sup>										
4.8 to 50.8, excl	12.7	0	12.7	0	12.7	0	12.7	0	12.7	0
50.8 to 76.2, incl	15.9	0	15.9	0	15.9	0	15.9	0	15.9	0

<sup>A</sup> Permissible variations in width for powder- or inert-arc-cut plate shall be as agreed upon between the manufacturer and the purchaser.  
<sup>B</sup> Permissible variations in machined, powder-, or inert-arc-cut circular plate shall be as agreed upon between the manufacturer and the purchaser.  
<sup>C</sup> Permissible variations in plasma-torch-cut sketch plates shall be as agreed upon between the manufacturer and the purchaser.  
<sup>D</sup> The minimum sheared width is 10 in. (254 mm) for material 3/4 in. (19.1 mm) and under in thickness and 20 in. (508 mm) for material over 3/4 in. (19.1 mm) in thickness.  
<sup>E</sup> The minimum abrasive-cut width is 2 in. (50.8 mm) and increases to 4 in. (101.6 mm) for thicker plates.  
<sup>F</sup> These tolerances are applicable to lengths of 240 in. (6100 mm), max. For lengths over 240 in., an additional 1/16 in. (1.6 mm) is permitted, both plus and minus.  
<sup>G</sup> The tolerance spread shown for plasma-torch cutting may be obtained all on the minus side, or divided between the plus and minus side if so specified by the purchaser.

TABLE 9 Permissible Variations in Diameter for Circular Plates

Specified Diameter, in. (mm)	Sheared Plate				
	Permissible Variations over Specified Diameter for Thickness Given, in. (mm) <sup>A</sup>				
	To 3/8 ( 9.5), incl				
20 to 32 (508 to 813), excl	1/4 (6.4)				
32 to 84 (813 to 2130), excl	5/16 (7.9)				
84 to 108 (2130 to 2740), excl	3/8 (9.5)				
108 to 140 (2740 to 3580), incl	7/16 (11.1)				
Specified Diameter, in. (mm)	Plasma-Torch-Cut Plate <sup>B</sup>				
	Thickness, max, in. (mm)	Permissible Variations in Specified Diameter for Thickness Given, in. (mm) <sup>C</sup>			
		3/16 to 2 (4.8 to 50.8), excl		2 to 3 (50.8 to 76.2), incl	
		+	-	+	-
19 to 20 (483 to 508), excl	3 (76.2)	1/2 (12.7)	0	5/8 (15.9)	0
20 to 22 (508 to 559), excl	2 3/4 (69.8)	1/2 (12.7)	0	5/8 (15.9)	0
22 to 24 (559 to 610), excl	2 1/2 (63.5)	1/2 (12.7)	0	5/8 (15.9)	0
24 to 28 (610 to 711), excl	2 1/4 (57.3)	1/2 (12.7)	0	5/8 (15.9)	0
28 to 32 (711 to 812), excl	2 (50.8)	1/2 (12.7)	0	5/8 (15.9)	0
32 to 34 (812 to 864), excl	1 3/4 (44.5)	1/2 (12.7)	0	...	...
34 to 38 (864 to 965), excl	1 1/2 (38.1)	1/2 (12.7)	0	...	...
38 to 40 (965 to 1020), excl	1 1/4 (31.8)	1/2 (12.7)	0	...	...
40 to 140 (1020 to 3560), incl	3 (76.2)	1/2 (12.7)	0	5/8 (15.9)	0

<sup>A</sup> No permissible variations under.  
<sup>B</sup> Permissible variations in plasma-torch-cut sketch plates shall be as agreed upon between the manufacturer and the purchaser.  
<sup>C</sup> The tolerance spread shown may also be obtained all on the minus side or divided between the plus and minus sides if so specified by the purchaser.

TABLE 10 Permissible Variations in Width of Sheet and Strip

Specified Thickness, in. (mm)	Specified Width, in. (mm)	Permissible Variations in Specified Width, in. (mm)	
		+	-
Up to 0.250 (6.35)	all	0.125 (3.18)	0
			Sheet
			Strip <sup>A</sup>
Under 0.075 (1.9)	Up to 12 (305), incl	0.007 (0.18)	0.007 (0.18)
	Over 12 to 48 (305 to 1219), incl	0.062 (1.6)	0
0.075 to 0.100 (1.9 to 2.5), incl	Up to 12 (305), incl	0.009 (0.23)	0.009 (0.23)
	Over 12 to 48 (305 to 1219), incl	0.062 (1.6)	0
Over 0.100 to 0.125 (2.5 to 3.2), incl	Up to 12 (305), incl	0.012 (0.30)	0.012 (0.30)
	Over 12 to 48 (305 to 1219), incl	0.062 (1.6)	0
Over 0.125 to 0.160 (3.2 to 4.1), incl	Up to 12 (305), incl	0.016 (0.41)	0.016 (0.41)
	Over 12 to 48 (305 to 1219), incl	0.062 (1.6)	0
Over 0.160 to 0.187 (4.1 to 4.7), incl	Up to 12 (305), incl	0.020 (0.51)	0.020 (0.51)
	Over 12 to 48 (305 to 1219), incl	0.062 (1.6)	0
Over 0.187 to 0.250 (4.7 to 6.4), incl	Up to 12 (305), incl	0.062 (1.6)	0.062 (1.6)
	Over 12 to 48 (305 to 1219), incl	0.062 (1.6)	0.062 (1.6)

<sup>A</sup> Rolled round or square-edge strip in thicknesses of 0.071 to 0.125 in. (1.80 to 3.18 mm), incl, in widths 3 in. (76.2 mm) and under, shall have permissible width variations of ±0.005 in. (±0.13 mm). Permissible variations for other sizes shall be as agreed upon between the manufacturer and the purchaser.

TABLE 11 Permissible Variations in Length<sup>A</sup> of Sheared, Plasma-Torch-Cut,<sup>B</sup> and Abrasive-Cut Rectangular Plate<sup>C</sup>

Specified Thickness	Permissible Variation in Length for Lengths Given, in. (mm)																
	Up to 60 (1520), incl		Over 60 to 96 (1520 to 2440), incl		Over 96 to 120 (2440 to 3050), incl		Over 120 to 240 (3050 to 6096), incl		Over 240 to 360 (6096 to 9144), incl		Over 360 to 450 (9144 to 11 430), incl		Over 450 to 540 (11 430 to 13 716), incl		Over 540 (13 716)		
	+	-	+	-	+	-	+	-	+	-	+	-	+	-	+	-	
	Inches																
Sheared: <sup>D</sup>																	
3/16 to 5/16, excl	3/16	1/8	1/4	1/8	3/8	1/8	1/2	1/8	5/8	1/8	3/4	1/8	7/8	1/8	...	...	
5/16 to 1/2, excl	3/8	1/8	1/2	1/8	1/2	1/8	1/2	1/8	5/8	1/8	3/4	1/8	7/8	1/8	1	1/8	
1/2 to 3/4, excl	1/2	1/8	1/2	1/8	5/8	1/8	5/8	1/8	3/4	1/8	7/8	1/8	1 1/8	1/8	1 3/8	1/8	
3/4 to 1, excl	5/8	1/8	5/8	1/8	5/8	1/8	3/4	1/8	7/8	1/8	1 1/8	1/8	1 3/8	1/8	1 5/8	1/8	
1 to 1 1/4, incl	3/4	1/8	3/4	1/8	3/4	1/8	7/8	1/8	1 1/8	1/8	1 3/8	1/8	1 5/8	1/8	...	...	
Abrasive-cut: <sup>E</sup>																	
3/16 to 1 1/4, incl	1/8	1/8	1/8	1/8	1/8	1/8	1/8	1/8	1/8	1/8	1/8	1/8	...	...	...	...	
Over 1 1/4 to 2 3/4, incl	3/16	1/8	3/16	1/8	3/16	1/8	3/16	1/8	3/16	1/8	3/16	1/8	...	...	...	...	
Plasma torch-cut: <sup>F</sup>																	
3/16 to 2, excl	1/2	0	1/2	0	1/2	0	1/2	0	1/2	0	1/2	0	1/2	0	1/2	0	
2 to 3, incl	5/8	0	5/8	0	5/8	0	5/8	0	5/8	0	5/8	0	5/8	0	5/8	0	
	Millimetres																
Sheared: <sup>D</sup>																	
4.8 to 7.9, excl	4.8	3.2	6.4	3.2	9.5	3.2	12.7	3.2	15.9	3.2	19.0	3.2	22.2	3.2	...	...	
7.94 to 12.7, excl	9.5	3.2	12.7	3.2	12.7	3.2	12.7	3.2	15.9	3.2	19.0	3.2	22.2	3.2	25.4	3.2	
12.7 to 19.0, excl	12.7	3.2	12.7	3.2	15.9	3.2	15.9	3.2	19.0	3.2	22.2	3.2	28.6	3.2	34.9	3.2	
19.0 to 25.4, excl	15.9	3.2	15.9	3.2	15.9	3.2	19.0	3.2	22.2	3.2	28.6	3.2	34.9	3.2	41.3	3.2	
25.4 to 31.8, incl	19.0	3.2	19.0	3.2	19.0	3.2	22.2	3.2	28.6	3.2	34.9	3.2	41.3	3.2	...	...	
Abrasive-cut: <sup>E</sup>																	
4.8 to 31.8, incl	3.2	3.2	3.2	3.2	3.2	3.2	3.2	3.2	3.2	3.2	3.2	3.2	...	...	...	...	
Over 31.8 to 69.9, incl	4.8	3.2	4.8	3.2	4.8	3.2	4.8	3.2	4.8	3.2	4.8	3.2	...	...	...	...	
Plasma torch-cut: <sup>F</sup>																	
4.8 to 50.8, excl	12.7	0	12.7	0	12.7	0	12.7	0	12.7	0	12.7	0	12.7	0	12.7	0	
50.8 to 76.2, incl	15.9	0	15.9	0	15.9	0	15.9	0	15.9	0	15.9	0	15.9	0	15.9	0	

<sup>A</sup> Permissible variations in length for powder- or inert-arc-cut plate shall be agreed upon between the manufacturer and the purchaser.  
<sup>B</sup> The tolerance spread shown for plasma-torch-cutting may be obtained all on the minus side, or divided between the plus and minus sides if so specified by the purchaser.  
<sup>C</sup> Permissible variations in machined, powder- or inert-arc-cut circular plate shall be as agreed upon between the manufacturer and the purchaser.  
<sup>D</sup> The minimum sheared length is 10 in. (254 mm).  
<sup>E</sup> Abrasive cut applicable to a maximum length of 144 to 400 in. (3658 to 10 160 mm) depending on the thickness and width ordered.  
<sup>F</sup> The tolerance spread shown for plasma-torch-cut sketch plates shall be as agreed upon between the manufacturer and the purchaser.

10.2.1 *Chemical Analysis*—Representative samples from each lot shall be taken during pouring or subsequent processing.

10.2.1.1 *Product (Check) Analysis* shall be wholly the responsibility of the purchaser.

10.2.2 *Mechanical Properties, Hardness, and Grain Size*—Samples of the material to provide test specimens for mechani-

cal properties, hardness, and grain size shall be taken from such locations in each lot as to be representative of that lot.

11. Number of Tests

11.1 *Chemical Analysis*—One test per lot.

11.2 *Mechanical Properties*—One test per lot.

**TABLE 12 Permissible Variations from Flatness of Rectangular, Circular, and Sketch Plates**

NOTE 1—Permissible variations apply to plates up to 12 ft (3660 mm) in length, or to any 12 ft (3660 mm) of longer plates.

NOTE 2—If the longer dimension is under 36 in. (914 mm), the permissible variation is not greater than ¼ in. (6.4 mm).

NOTE 3—The shorter dimension specified is considered the width, and the permissible variation in flatness across the width does not exceed the tabular amount of that dimension.

NOTE 4—The maximum deviation from a flat surface does not customarily exceed the tabular tolerance for the longer dimension specified.

Specified Thickness	Permissible Variations from a Flat Surface for Thickness and Widths Given, in. (mm)								
	To 48 (1220), excl	48 to 60 (1220 to 1520), excl	60 to 72 (1520 to 1830), excl	72 to 84 (1830 to 2130), excl	84 to 96 (2130 to 2440), excl	96 to 108 (2440 to 2740), excl	108 to 120 (2740 to 3050), excl	120 to 144 (3050 to 3660), excl	144 (3660), and over
Inches									
3/16 to 1/4, excl	3/4	1 1/16	1 1/4	1 3/8	1 3/8	1 3/8	...	...	...
1/4 to 3/8, excl	1 1/16	3/4	1 5/16	1 1/8	1 3/8	1 7/16	1 9/16	1 7/8	...
3/8 to 1/2, excl	1/2	9/16	1 1/16	3/4	1 5/16	1 1/8	1 1/4	1 7/16	1 3/4
1/2 to 3/4, excl	1/2	9/16	5/8	5/8	1 3/16	1 1/8	1 1/8	1 1/8	1 3/8
3/4 to 1, excl	1/2	9/16	5/8	5/8	3/4	1 3/16	1 5/16	1	1 1/8
1 to 2, excl	1/2	9/16	5/8	9/16	1 1/16	1 1/16	1 1/16	3/4	1
2 to 4, incl	1/4	5/16	3/8	7/16	1/2	9/16	5/8	3/4	7/8
Millimetres									
4.8 to 6.4, excl	19.0	27.0	31.8	34.9	41.3	41.3	...	...	...
6.4 to 9.5, excl	17.5	19.0	23.8	28.6	34.9	36.5	39.7	47.6	...
9.5 to 12.7, excl	12.7	14.3	17.5	19.0	23.8	28.6	31.8	36.5	44.4
12.7 to 19.0, excl	12.7	14.3	15.9	15.9	20.6	28.6	28.6	28.6	34.9
19.0 to 25.4, excl	12.7	14.3	15.9	15.9	19.0	20.6	23.8	25.4	28.6
25.4 to 50.8, excl	12.7	14.3	14.3	14.3	17.5	17.5	17.5	19.0	25.4
50.8 to 101.6, incl	6.4	7.9	9.5	11.1	12.7	14.3	15.9	19.0	22.2

11.3 **Hardness**—One test per lot. (Required only as specified in Table 3 and Table 4.)

11.4 **Grain Size**—One test per lot. (Required only as specified in 7.3 or Table 4.)

**12. Specimen Preparation**

12.1 Tension test specimens shall be taken from material in the final condition (temper) and tested transverse to the direction of rolling when width will permit.

12.2 Tension test specimens shall be any of the standard or subsize specimens shown in Test Methods E8/E8M.

12.3 In the event of disagreement, referee specimens shall be as follows:

12.3.1 Full thickness of the material, machined to the form and dimensions shown for the sheet-type specimen in Test Methods E8/E8M for material under 1/2 in. (12.7 mm) in thickness.

12.3.2 The largest possible round specimen shown in Test Methods E8/E8M for material 1/2 in. (12.7 mm) and over.

**13. Test Methods**

13.1 The chemical composition, mechanical, and other properties of the material as enumerated in this specification shall be determined, in case of disagreement, in accordance with the following methods:

Test	ASTM Designation
Chemical Analysis	E38, <sup>4</sup> E1473
Tension	E8/E8M
Brinell hardness	E10
Rockwell hardness	E18
Hardness conversion	E140
Grain size	E112
Rounding procedure	E29
Spring-back	F155

<sup>4</sup> Methods E38 are to be used only for elements not covered by Test Methods E1473.

13.2 The measurement of average grain size may be carried out by the planimetric method, the comparison method, or the intercept method described in Test Methods E112. In case of dispute, the referee method for determining average grain size shall be the planimetric method.

13.3 For purposes of determining compliance with the specified limits for requirements of the properties listed in the following table, an observed value or a calculated value shall be rounded as indicated in accordance with the rounding method of Practice E29.

Test	Rounded Unit for Observed or Calculated Value
Chemical composition, hardness, and tolerances (when expressed in decimals)	nearest unit in the last right-hand place of figures of the specified limit. If two choices are possible, as when the digits dropped are exactly a 5, or a 5 followed only by zeros, choose the one ending in an even digit, with zero defined as an even digit.
Tensile strength and yield strength	nearest 1000 psi (6.9 MPa)
Elongation	nearest 1 %
Grain Size:	
0.0024 in. (0.060 mm) or larger	nearest multiple of 0.0002 in. (0.005 mm)
less than 0.0024 in. (0.060 mm)	nearest multiple of 0.0001 in. (0.002 mm)

**14. Inspection**

14.1 Inspection of the material shall be made as agreed upon between the manufacturer and the purchaser as part of the purchase contract.

### 15. Rejection and Rehearing

15.1 Material that fails to conform to the requirements of this specification may be rejected. Rejection should be reported to the producer or supplier promptly and in writing. In case of dissatisfaction with the results of the test, the producer or supplier may make claim for a rehearing.

### 16. Certification

16.1 A manufacturer's certification shall be furnished to the purchaser stating that material has been manufactured, tested, and inspected in accordance with this specification, and that the test results on representative samples meet specification requirements. A report of the test results shall be furnished.

### 17. Product Marking

17.1 Each bundle or shipping container shall be marked with the name of the material or UNS number; condition (temper); this specification number; the size; gross, tare, and net weight; consignor and consignee address; contract or order number; or such other information as may be defined in the contract or order.

### 18. Keywords

18.1 plate; sheet; strip; UNS N06025; UNS N06045; UNS N06235; UNS N06600; UNS N06601; UNS N06603; UNS N06617; UNS N06674; UNS N06690; UNS N06693; UNS N06696; UNS N06699

## SUPPLEMENTARY REQUIREMENTS

The following supplementary requirements shall apply only when specified by the purchaser in the inquiry, contract, or order, for agencies of the U. S. Government.

### S1. Referenced Documents

S1.1 The following documents of the issue in effect on date of material purchased form a part of this specification to the extent referenced herein: Federal Standards 102, 123, and 182 and Military Standard MIL-STD-129.

### S2. Quality Assurance

S2.1 *Responsibility for Inspection*—Unless otherwise specified in the contract or purchase order, the manufacturer is responsible for the performance of all inspection and test requirements specified. Except as otherwise specified in the contract or purchase order, the manufacturer may use his own or any other suitable facilities for the performance of the inspection and test requirements unless disapproved by the purchaser at the time the order is placed. The purchaser shall have the right to perform any of the inspections or tests set forth when such inspections and tests are deemed necessary to ensure that the material conforms to prescribed requirements.

### S3. Identification Marking

S3.1 All material shall be properly marked for identification in accordance with Fed. Std. No. 182, except that the ASTM specification number and the alloy number shall be used.

### S4. Preparation for Delivery

S4.1 *Preservation, Packaging, Packing:*

S4.1.1 *Military Agencies*—The material shall be separated by size, composition, grade, or class and shall be preserved and packaged, Level A or C or packed, Level A, B, or C as specified in the contract or purchase order.

S4.1.2 *Civil Agencies*—The requirements of Fed. Std. No. 102 shall be referenced for definitions of the various levels of packaging protection.

S4.2 *Marking:*

S4.2.1 *Military Agencies*—In addition to any special marking required by the contract or purchase order, marking for shipment shall be in accordance with MIL-STD-129.

S4.2.2 *Civil Agencies*—In addition to any special marking required by the contract or purchase order, marking for shipment shall be in accordance with Fed. Std. No. 123.

## APPENDIX

## (Nonmandatory Information)

## X1. CONDITIONS AND FINISHES

**X1.1 Scope**

X1.1.1 This appendix lists the conditions and finishes in which plate, sheet, and strip are normally supplied. These are subject to change, and the manufacturer should be consulted for the latest information available.

**X1.2 Plate, Hot-Rolled**

X1.2.1 *Annealed*—Soft with an oxide surface, and suitable for heavy cold forming. Available with a descaled surface, when so specified.

X1.2.2 *As-Rolled*—With an oxide surface. Available with a descaled surface, when so specified. Suitable for flat work, mild forming, or tube sheets. When intended for tube sheets, specify that plates are to be specially flattened. When intended for hot forming, this should be indicated on the purchase order so that the manufacturer may select appropriate material.

**X1.3 Plate, Cold-Rolled**

X1.3.1 *Annealed*—Soft with an oxide surface; available in a descaled surface when so specified.

**X1.4 Sheet, Hot-Rolled**

X1.4.1 *Annealed and Pickled*—Soft with a pickled matte finish. Properties similar to X1.5.1 but with broader thickness tolerances. Not suggested for applications where the finish of a cold-rolled sheet is considered essential, or for deep drawing or spinning.

**X1.5 Sheet and Strip, Cold-Rolled**

X1.5.1 *Annealed*—Soft with a pickled or bright annealed finish.

X1.5.2 *Deep-Drawing or Spinning Quality*—Similar to X1.5.1, except furnished to controlled hardness and grain size and lightly leveled.

X1.5.3 *Skin-Hard*—Similar to X1.5.1, but given a light cold reduction to hardness range shown in Table 3.

X1.5.4 *Quarter-Hard*—Cold rolled to the hardness range indicated in Table 3, bright finish. Out-of-flatness must be expected and will vary with temper and thickness.

X1.5.5 *Half-Hard*—Cold rolled to the hardness range indicated in Table 3, bright finish. Out-of-flatness must be expected and will vary with temper and thickness.

X1.5.6 *Three-Quarter Hard*—Cold rolled to the hardness range indicated in Table 3, bright finish. Out-of-flatness must be expected and will vary with temper and thickness.

X1.5.7 *Hard*—Cold rolled to the tensile requirements indicated in Table 3, bright finish. Out-of-flatness must be expected and will vary with temper and thickness.

X1.5.8 *Spring Temper*—Cold rolled to the minimum hardness indicated in Table 3, bright finish. Out-of-flatness must be expected and will vary with temper and thickness.

ASMENORMDOC.COM : Click to view the full PDF of ASME BPVC.II.B (ASME BPVC Section II part B) 2025

INTENTIONALLY LEFT BLANK

## SPECIFICATION FOR ALUMINUM BRONZE SHEET, STRIP, AND ROLLED BAR



**SB-169/SB-169M**

(Identical with ASTM Specification B169/B169M-20 except that paras. 5.2.4 and 5.2.5 have been deleted. Certification and mill test reports have been made mandatory.)

# Specification for Aluminum Bronze Sheet, Strip, and Rolled Bar

## 1. Scope

1.1 This specification establishes the requirements for Copper Alloy UNS Nos. C61300 and C61400 aluminum bronze sheet, strip, and rolled bar.

1.2 The products made to this specification are commonly used for drawing, forming, stamping, and bending applications and are not intended for electrical applications.

NOTE 1—The products produced under this general specification may be used in many applications in which the individual requirements may be too specific to be determined by normal physical or mechanical testing. Therefore, it may be advisable for the purchaser to submit samples or drawings to the manufacturer to be assured that the product furnished is suitable for the intended application.

NOTE 2—Refer to Specification B171/B171M for plate product.

1.3 *Units*—The values stated in either inch-pound units or SI units are to be regarded separately as standard. Within the text, SI units are shown in brackets. The values stated in each system are not necessarily exact equivalents; therefore, to ensure conformance with the standard, each system shall be used independently of the other, and values from the two systems shall not be combined.

1.4 *This international standard was developed in accordance with internationally recognized principles on standardization established in the Decision on Principles for the Development of International Standards, Guides and Recommendations issued by the World Trade Organization Technical Barriers to Trade (TBT) Committee.*

## 2. Referenced Documents

### 2.1 ASTM Standards:

B171/B171M Specification for Copper-Alloy Plate and Sheet for Pressure Vessels, Condensers, and Heat Exchangers

B248 Specification for General Requirements for Wrought Copper and Copper-Alloy Plate, Sheet, Strip, and Rolled Bar

B248M Specification for General Requirements for Wrought Copper and Copper-Alloy Plate, Sheet, Strip, and Rolled Bar (Metric)

B601 Classification for Temper Designations for Copper and Copper Alloys—Wrought and Cast

B846 Terminology for Copper and Copper Alloys

E8/E8M Test Methods for Tension Testing of Metallic Materials

E290 Test Methods for Bend Testing of Material for Ductility

## 3. General Requirements

3.1 The following sections of Specifications B248 or B248M constitute a part of this specification.

3.1.1 Terminology

3.1.2 Workmanship, Finish, and Appearance

3.1.3 Sampling

3.1.4 Number of Tests and Retests

3.1.5 Specimen Preparation

3.1.6 Significance of Numerical Limits

3.1.7 Inspection

3.1.8 Rejection and Rehearing

3.1.9 Certification

3.1.10 Test Reports

3.1.11 Packaging and Package Marking

3.1.12 Supplementary Requirements

3.2 In addition, when a section with a title identical to that referenced in 3.1, above, appears in this specification, it contains additional requirements which supplement those appearing in Specifications B248 or B248M.

## 4. Terminology

4.1 For definitions of terms related to copper and copper alloys, refer to Terminology B846.

## 5. Ordering Information

5.1 Include the following specified choices when placing orders for product under this specification, as applicable:

5.1.1 ASTM designation and year of issue;

5.1.2 Copper [Alloy] UNS No. designation;

5.1.3 Temper, (Section 8);

5.1.4 Dimensions, thickness, width, and length (Section 11);

5.1.5 How furnished: straight lengths or coils; and

5.1.6 Quantity—total weight or total length or number of pieces of each size.

5.2 The following options are available but may not be included unless specified at the time of placing the order when required:

5.2.1 Type of edge (for example, slit, sheared, sawed, and so forth);

5.2.2 Heat identification or traceability details;

5.2.3 Bend test;

5.2.4 DELETED

5.2.5 DELETED

5.2.6 If product is purchased for agencies of the U.S. Government (see Supplementary Requirements section of Specifications B248 or B248M for additional requirements); and

5.2.7 DELETED

## 6. Materials and Manufacture

### 6.1 Materials:

6.1.1 The material of manufacture shall be a form (cast bar, cake, slab, etc.) of Copper Alloy UNS No. C61300 or C61400 of such purity and soundness as to be suitable for processing into the products prescribed herein.

### 6.2 Manufacture:

6.2.1 The product shall be manufactured by such hot working, cold working, and annealing processes as to produce a uniform wrought structure in the finished product.

6.2.2 The product shall be hot or cold worked to the finished size, and subsequently annealed, when required, to meet the temper properties specified.

### 6.3 Edges:

6.3.1 Slit edges shall be furnished unless otherwise specified in the contract or purchase order.

## 7. Chemical Composition

7.1 The material shall conform to the chemical composition requirements in Table 1 for the Copper [alloy] UNS No.

TABLE 1 Chemical Requirements

Element	Composition, %	
	Copper Alloy UNS No.	
	C61300 <sup>A</sup>	C61400
Copper (including Silver)	remainder	remainder
Lead, max	0.01	0.01
Iron	2.0–3.0	1.5–3.5
Zinc, max	0.10	0.20
Aluminum	6.0–7.5	6.0–8.0
Manganese, max	0.20	1.0
Phosphorus, max	0.015	0.015
Silicon, max	0.10	...
Tin	0.20–0.50	...
Nickel (including cobalt), max	0.15	...

<sup>A</sup> When the product is for subsequent welding applications and is so specified by the purchaser, chromium shall be 0.05 % max, cadmium 0.05 % max, zirconium 0.05 % max, and zinc 0.05 % max.

designation specified in the ordering information.

7.1.1 These composition limits do not preclude the presence of other elements. By agreement between the manufacturer and purchaser, limits may be established and analysis required for unnamed elements.

7.2 For alloys in which copper is listed as “remainder,” copper is the difference between the sum of results of all elements determined and 100 %. When all elements in Table 1 for the specified alloy are determined, the sum of the results shall be:

Copper Alloy UNS No.	Sum of Results % min.
C61300	99.8
C61400	99.5

## 8. Temper

8.1 The standard tempers for products described in this specification are given in Table 2 and Table 3.

8.1.1 Hot-rolled temper M20.

8.1.2 Annealed-to-temper O25 or O60.

NOTE 3—Inquiry should be made to the supplier concerning the availability of the specific temper required.

## 9. Mechanical Property Requirements

### 9.1 Tensile Strength Requirements:

9.1.1 Product furnished under this specification shall conform to the tensile requirements prescribed in Table 2 or Table 3 when tested in accordance with Test Methods E8/E8M.

9.1.2 The test specimens shall be taken so that the longitudinal axis of the specimen is parallel to the direction of rolling.

## 10. Bending Requirements

10.1 When specified in the contract or purchase order, the test specimen shall withstand being bent cold perpendicular to the direction of rolling (rightway bend) through 120° around a mandrel whose radius is equal to the thickness of the product. When the outside surface of the bend is examined with an unaided eye, no sign of fracturing shall be observed.

## 11. Dimensions, Mass, and Permissible Variations

11.1 The dimensions and tolerances for product described by this specification shall be as specified in Specification B248 or B248M.

11.2 Thickness (Table 1).

11.3 Width:

11.3.1 Slit Metal and Slit Metal with Rolled Edges (Table 4).

11.3.2 Square Sheared Metal (Table 5).

11.4 Length:

11.4.1 Length Tolerances for Straight Lengths (Table 7).

11.4.2 Schedule for Minimum Lengths and Maximum Weights of Ends for Specific Lengths with Ends, and Stock Lengths with Ends (Table 8).

11.4.3 Length Tolerance for Square Sheared Metal (Table 9).

11.4.4 Length Tolerances for Sawed Metal (Table 10).

11.5 Straightness:

TABLE 2 Tensile Requirements (Inch-Pound)

Copper Alloy UNS No.	Temper Designation <sup>A</sup>		Thickness, in.	Width, in.	Tensile Strength min, ksi <sup>B</sup>	Yield Strength at 0.5 % Extension Under Load, min, ksi <sup>B</sup>	Yield Strength at 0.2 % Extension Under Load, min, ksi <sup>B</sup>	Elongation in 2 in., min, %
	Code	Name						
C61300	O25, O60, or M20	soft	½ and under	all widths	75	36	34	35
			Over ½ to 2, incl	all widths	72	32	30	35
			Over 2 to 5, incl	all widths	65	28	26	35
C61400	O25, O60, or M20	soft	½ and under	all widths	72	32	30	35
			Over ½ to 2, incl	all widths	70	30	28	35
			Over 2 to 5, incl	all widths	65	28	26	35

<sup>A</sup> Standard designations defined in Classification B601.

<sup>B</sup> ksi = 1000 psi.

TABLE 3 Tensile Requirements (SI)

Copper Alloy UNS No.	Temper Designation <sup>A</sup>		Thickness, mm	Width, mm	Tensile Strength min, MPa	Yield Strength at 0.5 % Extension Under Load, min, MPa	Yield Strength at 0.2 % Extension Under Load, min, MPa	Elongation in 2 in., min, %
	Code	Name						
C61300	O25, O60, or M20	soft	12.0 and under	all widths	515	250	235	35
			Over 12.0 to 50.0, incl	all widths	495	220	205	35
			Over 50.0 to 140 incl	all widths	450	195	180	35
C61400	O25, O60, or M20	soft	12.0 and under	all widths	495	220	205	35
			Over 12.0 to 50.0, incl	all widths	485	205	195	35
			Over 50.0 to 140 incl	all widths	450	195	180	35

<sup>A</sup> Standard designations defined in Classification B601.

11.5.1 Slit Metal or Slit Metal Either Straightened or Edge Rolled (Table 11).

11.5.2 Square Sheared Metal (Table 12).

11.5.3 Sawed Metal (Table 13).

11.6 Edge Contours:

11.6.1 Square Corners (Table 14).

11.6.2 Rounded Corners (Table 15).

11.6.3 Rounded Edges (Table 16).

11.6.4 Full-Rounded Edges (Table 17).

**12. Number of Tests and Retests**

12.1 Tests:

12.1.1 *Chemical Analysis*—Chemical composition shall be determined in accordance with the element mean of the results from at least two replicate analyses of the sample(s).

12.1.2 *Mechanical Properties*—Tensile strength, yield strength, and elongation shall be reported as the average of results from at least two specimens.

12.1.3 *Bending Requirements*—Two specimens shall be tested and both shall pass.

**13. Specimen Preparation**

13.1 *Bend Test*—Bend test specimens shall be prepared as directed in Test Methods E290.

**14. Test Methods**

14.1 *Chemical Analysis:*

14.1.1 In cases of disagreement, tests methods for chemical analysis shall be subject to agreement between the manufacturer or supplier and the purchaser.

14.1.2 Test method(s) to be followed for the determination of element(s) resulting from contractual or purchase order agreement shall be as agreed upon between the manufacturer or supplier and purchaser.

14.2 *Other Tests:*

14.2.1 The product furnished shall conform to specified requirements when subjected to test in accordance with the following table:

Test	Method
Tensile strength	E8/E8M
Yield strength	E8/E8M
Elongation	E8/E8M
Bending	E290

14.2.2 *Yield Strength*—The yield strength shall be determined by the extension-under-load method of Test Methods E8/E8M. When test results are obtained from both full-size and machined specimens, and they differ, the test results from the full-size specimens shall prevail.

14.2.3 Elongation shall be determined as specified in the section of Test Methods E8/E8M, entitled “Elongation.”

14.2.4 Test results are affected by variations in speed of testing. A considerable range of testing speed is permitted. The rate of stressing to the yield strength should not exceed 100 ksi/min [690 MPa/min.]. Above the yield strength, the movement per minute of the testing machine head under load should not exceed 0.5 in./in [0.5 mm/mm].

## 15. Certification and Test Report

15.1 The manufacturer’s certificate of compliance shall be furnished to the purchaser stating that samples representing each lot have been tested and inspected in accordance with this specification and the requirements have been met.

15.2 The manufacturer shall furnish to the purchaser a test report showing results of tests required by the specification.

## 16. Keywords

16.1 aluminum bronze; aluminum bronze rolled bar; aluminum bronze sheet; aluminum bronze strip; UNS C61300; UNS C61400

ASMENORMDOC.COM : Click to view the full PDF of ASME BPVC.II.B (ASME BPVC Section II part B) 2025

ASMENORMDOC.COM : Click to view the full PDF of ASME BPVC.II.B (ASME BPVC Section II part B) 2025

INTENTIONALLY LEFT BLANK

# SPECIFICATION FOR COPPER-ALLOY PLATE AND SHEET FOR PRESSURE VESSELS, CONDENSERS, AND HEAT EXCHANGERS



**SB-171/SB-171M**

(Identical with ASTM Specification B171/B171M-18 except that certification and test reports have been made mandatory, and temper restrictions are removed.)

ASMENORMDOC.COM : Click to view the full PDF of ASME BPVC.II.B (ASME BPVC Section II part B) 2025

# Specification for Copper-Alloy Plate and Sheet for Pressure Vessels, Condensers, and Heat Exchangers

## 1. Scope

1.1 This specification establishes the requirements for copper-alloy plate, sheet, and circles cut from plate and sheet for pressure vessels, condensers, and heat exchangers. The following alloys are covered:

Copper Alloy	Previously Used Designation
C36500	Leaded Muntz Metal
C44300	Admiralty, Arsenical
C44400	Admiralty, Antimonial
C44500	Admiralty, Phosphorized
C46400	Naval Brass, Uninhibited
C46500	Naval Brass, Arsenical
C61300	Aluminum Bronze
C61400	Aluminum Bronze D
C63000	10 % Aluminum-Nickel Bronze
C63200	9 % Aluminum-Nickel Bronze
C70600	90-10 Copper Nickel
C70620	90-10 Copper Nickel-(modified for welding)
C71500	70-30 Copper Nickel
C71520	70-30 Copper Nickel-(modified for welding)
C72200	...

1.2 *Units*—The values stated in either inch-pound units or SI units are to be regarded separately as standard. Within the text, SI units are shown in brackets. The values stated in each system may not be exact equivalents; therefore, each system shall be used independently of the other. Combining values from the two systems may result in non-conformance with the standard.

1.3 *This international standard was developed in accordance with internationally recognized principles on standardization established in the Decision on Principles for the Development of International Standards, Guides and Recommendations issued by the World Trade Organization Technical Barriers to Trade (TBT) Committee.*

## 2. Referenced Documents

### 2.1 ASTM Standards:

- B248 Specification for General Requirements for Wrought Copper and Copper-Alloy Plate, Sheet, Strip, and Rolled Bar
- B248M Specification for General Requirements for Wrought Copper and Copper-Alloy Plate, Sheet, Strip, and Rolled Bar (Metric)
- B846 Terminology for Copper and Copper Alloys
- E8/E8M Test Methods for Tension Testing of Metallic Materials
- E29 Practice for Using Significant Digits in Test Data to Determine Conformance with Specifications
- E54 Test Methods for Chemical Analysis of Special Brasses and Bronzes (Withdrawn 2002)
- E62 Test Methods for Chemical Analysis of Copper and Copper Alloys (Photometric Methods) (Withdrawn 2010)
- E255 Practice for Sampling Copper and Copper Alloys for the Determination of Chemical Composition
- E478 Test Methods for Chemical Analysis of Copper Alloys
- E527 Practice for Numbering Metals and Alloys in the Unified Numbering System (UNS)

## 3. Terminology

3.1 For definitions of terms related to copper and copper alloys, refer to Terminology B846.

## 4. Ordering Information

4.1 Include the following specified choices when placing orders for product under this specification, as applicable:

- 4.1.1 ASTM designation and year of issue;
- 4.1.2 Whether inch-pound or SI units are applicable (see 1.2);
- 4.1.3 Copper [Alloy] UNS. No. (see Section 6, Table 1);

TABLE 1 Chemical Requirements

Copper Alloy UNS No. <sup>A</sup>	Composition, % max (Unless Shown as a Range)									
	Copper, incl Silver	Tin	Nickel, incl Cobalt	Manganese, max	Lead	Iron	Zinc	Aluminum	Chromium	Other Named Elements
C36500	58.0-61.0 <sup>B</sup>	0.25	...	...	0.25-0.7	0.15	remainder	...	...	...
C44300	70.0-73.0 <sup>B</sup>	0.8-1.2	...	...	0.07	0.06	remainder	...	...	0.02-0.06 As
C44400	70.0-73.0 <sup>B</sup>	0.8-1.2	...	...	0.07	0.06	remainder	...	...	0.02-0.10 Sb
C44500	70.0-73.0 <sup>B</sup>	0.8-1.2	...	...	0.07	0.06	remainder	...	...	0.02-0.10 P
C46400	59.0-62.0 <sup>B</sup>	0.50-1.0	...	...	0.20	0.10	remainder	...	...	...
C46500	59.0-62.0 <sup>B</sup>	0.50-1.0	...	...	0.20	0.10	remainder	...	...	0.02-0.06 As
C61300 <sup>C</sup>	remainder	0.20-0.50	0.15	0.20	0.01	2.0-3.0	0.10 <sup>D</sup>	6.0-7.5	...	0.10 Si 0.015 P
C61400	remainder	...	...	1.0	0.01	1.5-3.5	0.20	6.0-8.0	...	0.015 P
C63000	remainder	0.20	4.0-5.5	1.5	...	2.0-4.0	0.30	9.0-11.0	...	0.25 Si
C63200	remainder	...	4.0-4.8 <sup>E</sup>	1.2-2.0	0.02	3.5-4.3 <sup>E</sup>	...	8.7-9.5	...	0.10 Si
C70600	remainder	...	9.0-11.0	1.0	0.05 <sup>D</sup>	1.0-1.8	1.0 <sup>D</sup>	...	...	...
C70620	86.5 min	...	9.0-11.0	1.0	0.02	1.0-1.8	0.50	...	...	0.05 C 0.02 P 0.02 S
C71500	remainder	...	29.0-33.0	1.0	0.05 <sup>D</sup>	0.40-1.0	1.0 <sup>D</sup>	...	...	...
C71520	65.0 min	...	29.0-33.0	1.0	0.02	0.40-1.0	0.50	...	...	0.05 C 0.02 P 0.02 S
C72200	remainder	...	15.0-18.0	1.0	0.05 <sup>D</sup>	0.50-1.0	1.0 <sup>D</sup>	...	0.30-0.70	0.03 Si 0.03 Ti <sup>D</sup>

<sup>A</sup> Designation established in accordance with Practice E527.

<sup>B</sup> Not including silver.

<sup>C</sup> When the product is for subsequent welding applications, and is so specified by the purchaser, chromium shall be 0.05 % max, cadmium 0.05 % max, zirconium 0.05 % max and zinc 0.05 % max.

<sup>D</sup> When the product is for subsequent welding applications, and is so specified by the purchaser, zinc shall be 0.50 % max, lead 0.02 % max, phosphorus 0.02 % max, sulfur 0.02 % max, and carbon 0.05 % max.

<sup>E</sup> Iron content shall not exceed the nickel content.

4.1.4 Whether the alloy ordered will be used in applications requiring it to be welded (see Table 1, footnotes C and D for UNS Nos. C61300 and C72200, respectively, and UNS Nos. C70620 and C71520 in place of UNS Nos. C70600 and C71500);

4.1.5 Whether plate is to be machined (see 9.1.3);

4.1.6 How tolerance is specified (Table 2, footnote A); and

4.1.7 Weight (total for each size).

4.2 The following options are available but may not be included unless specified at the time of placing the order, when required.

4.2.1 DELETED

4.2.2 DELETED

4.2.3 Special marking, if required (Section 20);

4.2.4 Whether yield strength 0.2 % offset is required;

4.2.5 Heat identification or traceability details (5.1.2); and

4.2.6 Source inspection (15.2).

5. Materials and Manufacture

5.1 Material:

5.1.1 The material of manufacture shall be cast cake of the Copper Alloy UNS No. specified in the purchase order of such purity and soundness as to be suitable for processing into the products prescribed herein.

5.1.2 When specified in the contract or purchase order that heat identification or traceability is required, the purchaser shall specify the details desired.

NOTE 1—Due to the discontinuous nature of the processing of castings into wrought products, it is not always practical to identify a specific casting analysis with a specific quantity of finished material.

TABLE 2 Thickness Tolerances

Thickness, in. [mm]	Thickness Tolerances, Plus and Minus, <sup>A,B</sup> in. [mm] for Diameters or Widths			
	36 in. [1000 mm] or Under, incl	Over 36 to 60 in. [1000 to 1500 mm], incl	Over 60 to 96 in. [1500 to 2500 mm], incl	Over 96 to 132 in. [2500 to 3500 mm], incl
Over 0.125 to 0.250 [3.0 to 6.0 mm], incl	0.010 [0.25]	0.012 [0.30]	0.022 [0.56]	0.028 [0.71]
Over 0.250 to 0.500 [6.0 to 12.0 mm], incl	0.025 [0.64]	0.027 [0.69]	0.029 [0.74]	0.031 [0.79]
Over 0.500 to 0.750 [12.0 to 19.0 mm], incl	0.028 [0.71]	0.030 [0.76]	0.032 [0.81]	0.035 [0.89]
Over 0.750 to 1.000 [19.0 to 25.0 mm], incl	0.033 [0.84]	0.035 [0.89]	0.037 [0.94]	0.040 [1.0]
Over 1.000 to 1.500 [25.0 to 38.0], incl	0.038 [0.97]	0.040 [1.0]	0.042 [1.1]	0.045 [1.1]
Over 1.500 to 1.750 [38.0 to 44.0 mm], incl	0.043 [1.1]	0.045 [1.1]	0.047 [1.2]	0.050 [1.3]
Over 1.750 to 2.000 [44.0 to 50.0 mm], incl	0.050 [1.3]	0.055 [1.4]	0.062 [1.6]	0.065 [1.7]
Over 2.000 to 5.000 [50.0 to 127 mm], incl	0.058 [1.5]	0.062 [1.6]	0.065 [1.7]	...

<sup>A</sup> When tolerances are specified as all plus or all minus, double the values given.

<sup>B</sup> See 9.1.2 for specific alloys with a difference tolerance.

5.2 *Manufacture:*

5.2.1 The product shall be manufactured by such hot working, cold working, and annealing processes as to produce a uniform wrought structure in the finished product.

5.2.2 The product shall be hot or cold worked to the finished size, and subsequently annealed, when required, to meet the temper properties specified.

6. **Chemical Composition**

6.1 The materials shall conform to the chemical compositional requirements specified in Table 1 for the copper [alloy] UNS designations specified in the ordering information.

6.2 These composition limits do not preclude the presence of other elements. By agreement between the manufacturer and purchaser, limits may be established and analysis required for unnamed elements.

6.3 For the alloys listed below, zinc is listed as “remainder,” either copper or zinc, respectively, may be taken as the difference between the sum of all the elements analyzed and 100 %. When all the elements in Table 1 are analyzed their sum shall be as shown below:

Copper Alloy UNS No.	Copper Plus Named Elements, % min
C36500	99.6
C44300	99.6
C44400	99.6
C44500	99.6
C46400	99.6
C46500	99.6

6.3.1 For the alloys listed below, copper may be taken as the difference between the sum of all the elements and 100 %. When all of the elements in Table 1 are analyzed, their sum shall be as shown below:

Copper Alloy UNS No.	Copper Plus Named Elements, % min
C61300	99.8
C61400	99.5
C63000	99.5
C63200	99.5
C70600	99.5
C70620	99.5
C71520	99.5
C71500	99.5
C72200	99.8

7. **Temper**

7.1 The standard tempers for products described in this specification are given in Table 3.

7.1.1 As Hot Rolled Temper M20.

7.1.2 As Hot Forged-Air Cooled M10.

7.1.3 Hot Forged and Annealed O20.

7.1.4 Hot Rolled and Annealed O25.

7.1.5 DELETED

7.1.6 DELETED

8. **Mechanical Property Requirements**

8.1 *Tensile Strength Requirements:*

8.1.1 Product furnished under this specification shall conform to the mechanical property requirements prescribed in Table 3, when tested in accordance with Test Methods E8/E8M.

8.1.2 Acceptance or rejection shall be based upon the 8.1.1 mechanical properties.

TABLE 3 Tensile Requirements—M20, M10, O20, and O25 Tempers

Copper Alloy UNS No.	Thickness, in. [mm]	Tensile Strength, min, ksi <sup>A</sup> [MPa]	Yield Strength, <sup>B</sup> min, ksi <sup>A</sup> [MPa]	Yield Strength 0.2 % Offset, min, ksi <sup>A</sup> [MPa]	Elongation in 2 in. [50.0 mm], min, %
C36500	2 [50.0] and under	50 [345]	20 [140]	20 [140]	35 [35]
	over 2 to 3.5 [50.0 to 100.0], incl	45 [310]	15 [105]	15 [105]	35 [35]
	over 3.5 to 5 [100.0 to 140.0], incl	40 [275]	12 [85]	12 [85]	35 [35]
C44300, C44400, and C44500	4 [100.0] and under	45 [310]	15 [105]	15 [105]	35 [35]
C46400, C46500	3 [80.0] and under	50 [345]	20 [140]	20 [140]	35 [35]
	over 3 to 5 [80.0 to 140.0], incl	50 [345]	18 [125]	18 [125]	35 [35]
C61300	2 [50.0] and under	75 [515]	37 [255]	36 [250]	30 [30]
	over 2 to 3 [50.0 to 80.0], incl	70 [485]	30 [205]	28 [195]	35 [35]
	over 3 to 5 [80.0 to 140.0], incl	65 [450]	28 [195]	26 [180]	35 [35]
C61400	2 [50.0] and under	70 [485]	30 [205]	28 [195]	35 [35]
	over 2 to 5 [50.0 to 140.0], incl	65 [450]	28 [195]	26 [180]	35 [35]
	2 [50.0] and under	90 [620]	36 [250]	34 [235]	10 [10]
C63000 and C63200	over 2 to 3.5 [50.0 to 100.0], incl	85 [585]	33 [230]	31 [215]	10 [10]
	over 3.5 to 5.0 [100.0 to 140.0], incl	80 [550]	30 [205]	28 [195]	10 [10]
	2.5 [60.0] and under	40 [275]	15 [105]	15 [105]	30 [30]
C70600 and C70620	over 2.5 to 5 [60.0 to 140.0], incl	40 [275]	15 [105]	15 [105]	30 [30]
	2.5 [60.0] and under	50 [345]	20 [140]	20 [140]	30 [30]
C71500 and C71520	over 2.5 to 5 [60.0 to 140.0], incl	45 [310]	18 [125]	18 [125]	30 [30]
	2.5 [60.0] and under	42 [290]	16 [110]	16 [110]	35 [35]

<sup>A</sup> ksi = 1000 psi.

<sup>B</sup> Yield strength is measured at 0.5 % extension under load (that is, 0.01 in. [0.254 mm] in a gage length of 2 in. [50.0 mm]).

## 9. Dimensions, Mass, and Permissible Variations

### 9.1 Thickness:

9.1.1 The thickness tolerances for plates of Copper Alloy UNS Nos. C36500, C44300, C44400, C44500, C46400, and C46500 shall be as prescribed in Table 2.

9.1.2 The thickness tolerances for plates of Copper Alloy UNS Nos. C61300, C61400, C63000, C63200, C71500, C70620, C71520, and C72200 shall be 25 % greater than those prescribed in Table 2.

9.1.3 If plates are machined, the thickness tolerances shall apply to the machined portion only.

9.1.4 Closer thickness tolerances than those prescribed in Table 2 can be furnished by surface machining. This is a special product and is subject to agreement between the manufacturer and the purchaser. This special product shall apply only when specified by the purchaser in the contract or order.

9.1.5 Unless otherwise agreed to by the manufacturer and the purchaser, the thickness of plate to this specification shall be determined by measuring along the length of the plate up to a distance of 7 in. [180 mm] from the edge.

9.2 *Diameters, Lengths, or Widths*—The diameters, lengths, or widths of plates shall be not less than those specified. The diameters, lengths, or widths of plates may exceed those specified by the amounts shown in Table 4.

NOTE 2—For the purpose of determining conformance with the dimensional requirements prescribed in this specification, any measured value outside the specified limiting values for any dimension may be cause for rejection.

9.3 *Flatness*—The flatness tolerances of individual plates shall not exceed those prescribed in Table 5. The tolerances shown are the total permissible variations for plates as ordered, and do not apply to the 7 in. [180 mm] marginal area at the edge of the plate. Inspection for flatness shall be made by placing the plate on a flat surfaced table with the side marked “Straight Side” up, applying a 72 in. [2 m] straightedge when the size permits, or a shorter one equal to the dimensions to be inspected, and measuring the depth of arc between the straightedge and the plate.

9.4 *Plate and Sheet Lot Weight for Pressure Vessels*—For Copper Alloy UNS Nos. C70600, C70620, C17500, C17520 or C72200, the maximum lot weight restriction in Table 6 shall apply in addition to the thickness tolerance requirement of Table 2. The weight of each lot of five or more plates or sheets shall not exceed the nominal weight by more than the amount prescribed in Table 6. Plate and sheet of lots of less than five

TABLE 4 Diameter, Length, or Width Tolerances

Diameter, Length, or Width in. [mm]	Permissible Excess in Diameter, Length, or Width, in. [mm]
36 [1000] or under	$\frac{3}{64}$ [1.2]
Over 36 to 60 [1000 to 1500], incl	$\frac{1}{16}$ [1.6]
Over 60 to 96 [1500 to 2500], incl	$\frac{3}{32}$ [2.4]
Over 96 to 132 [2500 to 3500], incl	$\frac{7}{64}$ [2.8]

TABLE 5 Flatness Tolerances

Copper Alloy UNS No.	Flatness Tolerances (Depth of Arc) Not to Exceed, in. [mm], for Diameters, Lengths, or Widths Shown		
	36 in. [1000 mm] or Under	Over 36 to 60 in. [1000 to 1500 mm], incl	Over 60 to 132 in. [1500 to 3500 mm], incl <sup>A</sup>
C36500, C46400, and C46500	0.050 [1.3]	0.055 [1.4]	0.060 [1.5]
C44300, C44400, and C44500	0.050 [1.3]	0.065 [1.7]	0.075 [1.9]
C61300, C61400, C63000, and C63200	0.060 [1.5]	0.075 [1.9]	0.090 [2.3]
C70600, C71500, C72200, C70620, and C71520	0.060 [1.5]	0.075 [1.9]	0.090 [2.3]

<sup>A</sup> Tolerance applies to any 72 in. [1.83 m] chord.

shall be governed solely by the thickness tolerances of Table 2. For purposes of calculating weights, the densities used shall be as listed in Table 7.

## 10. Workmanship, Finish, and Appearance

10.1 The product shall be free of defects, but blemishes of a nature that do not interfere with the intended application are acceptable.

## 11. Sampling

11.1 The lot size, portion size, and selection of pieces shall be as follows:

11.1.1 *Lot Size*—10 000 lb [4550 kg] or less material of the same mill form, alloy, temper, and thickness, subject to inspection at one time.

11.1.2 *Portion Size*—Four individual sample pieces shall be selected as representative of each lot. If the lot consists of less than four pieces, samples shall be selected so as to be representative of each piece.

11.2 *Chemical Analysis*—A sample for chemical analysis shall be taken and prepared in accordance with Practice E255. Drillings, millings, and so forth, shall be taken in approximately equal weight from each of the sample pieces selected in accordance with 11.1.2 and combined into one composite sample. The minimum weight of the composite sample that is to be divided into three equal parts shall be 150 g.

11.2.1 Instead of sampling in accordance with Practice E255, the manufacturer shall have the option of determining conformance to chemical composition by analyzing samples taken at the time castings are poured or samples taken from the semi-finished product. If the manufacturer determines the chemical composition of the material during the course of manufacture, he shall not be required to sample and analyze the finished product. The number of samples taken for determination of chemical composition shall be as follows:

11.2.1.1 When samples are taken at the time the castings are poured, at least one sample shall be taken for each group of castings poured simultaneously from the same source of molten metal.

11.2.1.2 When samples are taken from the semi-finished product, a sample shall be taken to represent each 10 000 lb [4550 kg] or fraction thereof, except that not more than one sample shall be required per piece.

**TABLE 6 Lot Weight Tolerances in Percentage of Theoretical Weight, All Plus Copper Alloy UNS Nos. C70600, C71500, C72200, C71520, and C70620 for Use in Pressure Vessels Exclusively**

Specified Thicknesses, in. [mm]	Permissible Excess in Average Weights of Lots, Expressed in Percentage of Nominal Weights					
	48 in. [1200 mm] and Under in Width	Over 48 to 60 in. [1200 to 1500 mm] in Width, incl	Over 60 to 72 in. [1500 to 1800 mm] in Width, incl	Over 72 to 96 in. [1800 to 2500 mm] in Width, incl	Over 96 to 120 in. [2500 to 3000 mm] in Width, incl	Over 120 to 132 in. [3000 to 3400 mm] in Width, incl
Over 1/8 to 3/16 [3.0 to 5.0], incl	6.5	8	9	11	...	...
Over 3/16 to 1/4 [5.0 to 6.0], incl	6.5	8	9	11	12	...
Over 1/4 to 5/16 [6.0 to 8.0], incl	6.5	7.75	8.75	11	12	13
Over 5/16 to 3/8 [8.0 to 10.0], incl	6.25	7.5	8.5	11	12	13
Over 3/8 to 1/2 [10.0 to 12.0], incl	6	6	8	10	11	12
Over 1/2 to 5/8 [12.0 to 16.0], incl	5.75	6.5	7.5	9	10	11
Over 5/8 to 3/4 [12.0 to 20.0], incl	5.5	6	7	8	9	10
Over 3/4 to 1 [20 to 25.0], incl	5	5	6.25	7	8	9
Over 1 to 2 [25.0 to 50.0], incl	3.5	4	5	6	7	8

**TABLE 7 Densities**

Copper Alloy UNS Nos.	Density lb/in. <sup>3</sup> [g/cm <sup>3</sup> ]
C36500	0.304 [8.41]
C44300, C44400, and C44500	0.308 [8.53]
C46400, C46500	0.304 [8.41]
C61300, C61400	0.285 [7.89]
C63000 and C63200	0.274 [7.58]
C70600, C71500, C72200, C70620, and C71520	0.323 [8.94]

11.2.2 Because of the discontinuous nature of the processing of castings into wrought products, it is not practical to keep specific casting analysis identified with a specific quantity of finished material.

11.2.3 In the event that heat identification or traceability is required, the purchaser shall specify the details desired.

**12. Number of Tests and Retests**

12.1 *Tests:*

12.1.1 *Chemical Analysis*—Chemical composition shall be determined as the per element mean of results from at least two replicate analyses of the sample(s).

12.2 *Other Tests*—For other tests, a specimen shall be taken from two of the sample pieces selected in accordance with 11.1.2. The required tests shall be made on each of the specimens so selected.

12.3 *Retests:*

12.3.1 If any test specimen shows defective machining or develops flaws, it may be discarded and another specimen substituted.

12.3.2 If the percent elongation of any test specimen is less than that specified, and any part of the fracture is outside the middle two-thirds of the gage length, or in a punched or scribed mark within the reduced section, a retest shall be allowed.

12.3.3 If one of the tests made to determine any of the mechanical properties fails to meet a specified limit, this test shall be repeated on two of the remaining pieces selected in accordance with 11.1.2, and the results of both of these tests shall comply with the specified requirements.

12.3.4 When requested by the manufacturer or supplier, a retest shall be permitted when results of tests obtained by the purchaser fail to conform to the requirements of the product specification.

12.3.5 The retest shall be as directed in the product specification for the initial test, except the number of test specimens shall be twice that normally required for the specified test.

12.3.6 If the chemical analysis fails to conform to the specified limits, analysis shall be made on a new composite sample prepared from the pieces selected in accordance with 11.1.2. The results of the retest shall conform with the specified requirements.

12.3.7 All test specimens shall conform to the product specification requirement(s) in retest. Failure to conform shall be cause for rejection.

**13. Test Methods**

13.1 The properties and chemical compositions enumerated in this specification shall, in case of disagreement, be determined in accordance with the following ASTM test methods:

13.1.1 *Tension*—Tensile properties shall be determined in accordance with Test Methods E8/E8M using the specimens shown in Fig. 7 or 8.

13.1.2 *Chemical Analysis*—In cases of disagreement, test methods for chemical analysis shall be subject to agreement between the manufacturer or supplier and the purchaser. The following table is a list of published methods, some of which may no longer be viable, and which, along with others not listed, may be used subject to agreement:

Element	Test Method
Copper	E478
Aluminum	E478
Antimony	E62
Arsenic	E62
Iron	
<1.3 %	E478
>1.3 %	E54
Lead	E478 (AA)
Manganese	E62
Nickel:	
<5 %	E478 (photometric)
>5 %	E478 (gravimetric)
Phosphorus	E62
Silicon	E54 (perchloric acid)
Tin	E478
Zinc	
<2 %	E478 (AA)
>2 %	E478 (titrametric)

NOTE 3—The tension test specimen shall conform to the dimensions shown in Figs. 7 or 8 of Test Methods E8/E8M.

13.2 In case of disagreement, the sulfur content of the alloys covered in this specification shall be determined in accordance with the method given in the annex to Specification B248 or B248M.

13.3 Test method(s) to be followed for the determination of element(s) resulting from contractual or purchase order agreement shall be as agreed upon between the manufacturer or supplier and purchaser.

#### 14. Significance of Numerical Limits

14.1 For purposes of determining compliance with the specified limits for requirements of the properties listed in the following table and for dimensional tolerances, an observed or a calculated value shall be rounded as indicated in accordance with the rounding method of Practice E29:

Property	Rounded Unit for Observed or Calculated Value
Chemical composition	nearest unit in the last right hand significant digit used in expressing the limiting value
Tensile strength	nearest ksi [nearest 5 MPa]
Yield strength	nearest ksi [nearest 5 MPa]
Elongation of 5 % and over	nearest 1 %

#### 15. Inspection

15.1 The manufacturer shall inspect and make the tests necessary to verify that the product furnished conforms to the requirements of this specification.

15.2 If, in addition, source inspection of the material by the purchaser is agreed upon by the manufacturer and the purchaser as part of the purchase contract, the nature of the facilities needed to satisfy the inspector representing the purchaser that the product is being furnished in accordance with this specification shall be included in the agreement. All tests and the inspection shall be conducted so as not to interfere unnecessarily with the operation of the works.

15.3 When mutually agreed upon, the manufacturer or supplier and the purchaser shall conduct the final inspection simultaneously.

#### 16. Rejection and Rehearing

##### 16.1 Rejection:

16.1.1 Product that fails to conform to the requirements of this specification when tested by the purchaser or the purchaser's agent shall be subject to rejection.

16.1.2 Rejection shall be reported to the manufacturer or supplier promptly. In addition, a written notification shall follow.

16.1.3 In case of dissatisfaction with the results of the test upon which the rejection is based, the manufacturer or supplier shall have the option to make claim for a rehearing.

##### 16.2 Rehearing:

16.2.1 As a result of product rejection, the manufacturer or supplier shall have the option to make claim for a retest to be conducted by the manufacturer or supplier and the purchaser. Samples of the rejected product shall be taken in accordance with the product specification and subjected to test by both

parties using the test method(s) specified in the product specifications, or alternatively, upon agreement of both parties, an independent laboratory may be selected for the test(s) using the test method(s) specified in the product specification.

#### 17. Certification

17.1 The manufacturer shall furnish to the purchaser a certificate stating that each lot has been sampled, tested, and inspected in accordance with this specification and has met the requirements.

17.2 DELETED

#### 18. Test Report

18.1 A report of test results shall be furnished.

#### 19. Product Marking

19.1 The name or trademark of the manufacturer and the manufacturer's lot identification number shall be legibly stamped on each finished plate and sheet in two places not less than 12 in. [300 mm] from the edges. If the plate and sheet are too small to locate the markings in this way, the markings may be placed near the center of the plate and sheet. In case of butt straps, the markings may be placed 12 in. [300 mm] from the end. The plate number and type shall be legibly stamped on each plate and on each test specimen.

#### 20. Packaging and Package Marking

20.1 *Packaging*—The product shall be separated by size, composition, and temper, and prepared for shipment in such a manner as to ensure acceptance by common carrier for transportation and to afford protection from the normal hazards of transportation.

##### 20.2 Package Marking:

20.2.1 Each shipping unit shall be legibly marked with the purchase order number, metal or alloy designation, temper, size, shape, gross and net weight, and name of supplier. The specification number shall be shown, when specified.

20.2.2 When specified in the contract or purchaser order, the specification number shall be shown, when specified.

#### 21. Keywords

21.1 admiralty metal plate and sheet; aluminum bronze plate and sheet; aluminum-nickel bronze plate and sheet; copper nickel plate and sheet; muntz metal plate and sheet; naval brass plate and sheet; plate and sheet for pressure vessels; UNS No. C36500; UNS No. C43300; UNS No. C44400; UNS No. C44500; UNS No. C46400; UNS No. C46500; UNS No. C61300; UNS No. C61400; UNS No. C63000; UNS No. C63200; UNS No. C70600; UNS No. C70620; UNS No. C71500; UNS No. C71520; UNS No. C72200

## SUPPLEMENTARY REQUIREMENTS

The following supplementary requirements shall apply only when specified by the purchaser in the inquiry, contract, or order, for agencies of the U.S. Government.

### S1. Reference Documents

S1.1 The following documents of the issue in effect on date of material purchase form a part of this specification to the extent herein:

S1.1.1 *ASTM Standard:*

B900 Practice for Packaging of Copper and Copper Alloy Mill Products for U.S. Government Agencies

S1.1.2 *Federal Standards:*

Fed Std 102 Preservation, Packaging and Packing Levels

Fed Std 123 Marking for Shipment (Civil Agencies)

Fed Std 185 Identification Marking of Copper and Copper-Base Alloy Mill Products

S1.1.3 *Military Standard:*

MIL-STD-129 Marking for Shipment and Storage

### S2. Quality Assurance

S2.1 *Responsibility for Inspection*—Unless otherwise specified in the contract or purchase order, the manufacturer is responsible for the performance of all inspection and test requirements specified. Except as otherwise specified in the contract or purchase order, the manufacturer shall use any suitable facilities for the performance of the inspection and test requirements unless disapproved by the purchaser at the time

the order is placed. The purchaser shall have the right to perform any of the inspections or tests set forth when such inspections and tests are deemed necessary to assure that the material conforms to prescribed requirements.

### S3. Identification Marking

S3.1 All material shall be properly marked for identification in accordance with Fed. Std. 185 except that the ASTM specification number and the alloy number shall be used.

### S4. Preparation for Delivery

S4.1 *Preservation, Packaging, and Packing:*

S4.1.1 *Military Agencies*—The material shall be separated by size, composition, grade, or class and shall be preserved and packaged, Level A or C, and packed, Level A, B, or C, as specified in the contract or purchase order in accordance with the requirements of B900.

S4.1.2 *Civil Agencies*—The requirements of Fed. Std. 102 shall be referenced for definitions of the various levels of packaging protection.

S4.2 *Marking:*

S4.2.1 *Military Agencies*—In addition to any special marking required by the contract or purchase order, marking for shipment shall be in accordance with MIL-STD-129.

S4.2.2 *Civil Agencies*—In addition to any special marking required by the contract or purchase order, marking for shipment shall be in accordance with Fed. Std. 123.

# SPECIFICATION FOR COPPER, BUS BAR, ROD, AND SHAPES AND GENERAL PURPOSE ROD, BAR, AND SHAPES



**SB-187/SB-187M**

(Identical with ASTM Specification B187/B187M-20 except that certification and mill test reports have been made mandatory. Table 2, Footnote F and 10.1.1 are revised; 10.1.1.1 is deleted to make tensile testing required for all product forms.)

# Specification for Copper, Bus Bar, Rod, and Shapes and General Purpose Rod, Bar, and Shapes

## 1. Scope

1.1 This specification establishes the requirements for copper conductor bar, rod, and shapes for electrical (bus) applications and rod, bar, and shapes for general applications.

1.1.1 The products for electrical (bus) applications shall be made from the following coppers:

Copper UNS No.	Reference Designation
C10100	OFE
C10200	OF
C10300	OFXLP
C10400, C10500, C10700	OFS
C10920, C10930, C10940	—
C11000	ETP
C11020	FRHC
C11300, C11400, C11500,	STP
C11600	
C12000	DLP

1.1.1.1 The product may be furnished from any copper listed unless otherwise specified in the contract or purchase order.

1.2 The product for general applications shall be made from any of the coppers in 1.1.1 or the following coppers:

Copper UNS No.	Reference Designation
C10800	OFLP
C12200	DHP

1.2.1 The product may be furnished from any copper listed above unless otherwise specified in the contract or purchase order. Other coppers may be used upon agreement between the supplier and purchaser.

1.3 *Units*—The values stated in either inch-pound units or SI units are to be regarded separately as standard. Within the text, SI units are shown in brackets. The values stated in each

system are not necessarily exact equivalents; therefore, to ensure conformance with the standard, each system shall be used independently of the other, and values from the two systems shall not be combined.

NOTE 1—Material for hot forging will be found in Specification B124/B124M.

1.4 *This international standard was developed in accordance with internationally recognized principles on standardization established in the Decision on Principles for the Development of International Standards, Guides and Recommendations issued by the World Trade Organization Technical Barriers to Trade (TBT) Committee.*

## 2. Referenced Documents

### 2.1 ASTM Standards:

- B124/B124M Specification for Copper and Copper Alloy Forging Rod, Bar, and Shapes
- B170 Specification for Oxygen-Free Electrolytic Copper—Refinery Shapes
- B193 Test Method for Resistivity of Electrical Conductor Materials
- B216 Specification for Tough-Pitch Fire-Refined Copper—Refinery Shapes
- B224 Classification of Coppers
- B249/B249M Specification for General Requirements for Wrought Copper and Copper-Alloy Rod, Bar, Shapes and Forgings
- B577 Test Methods for Detection of Cuprous Oxide (Hydrogen Embrittlement Susceptibility) in Copper
- B601 Classification for Temper Designations for Copper and Copper Alloys—Wrought and Cast
- B846 Terminology for Copper and Copper Alloys
- B900 Practice for Packaging of Copper and Copper Alloy Mill Products for U.S. Government Agencies
- E53 Test Method for Determination of Copper in Unalloyed Copper by Gravimetry

E62 Test Methods for Chemical Analysis of Copper and Copper Alloys (Photometric Methods) (Withdrawn 2010)  
 E255 Practice for Sampling Copper and Copper Alloys for the Determination of Chemical Composition  
 E478 Test Methods for Chemical Analysis of Copper Alloys  
 E527 Practice for Numbering Metals and Alloys in the Unified Numbering System (UNS)  
 E1004 Test Method for Determining Electrical Conductivity Using the Electromagnetic (Eddy Current) Method  
 E2575 Test Method for Determination of Oxygen in Copper and Copper Alloys by Inert Gas Fusion

2.2 *Other Standard:*

ASME Boiler and Pressure Vessel Code

### 3. Terminology

3.1 For definitions of terms related to copper and copper alloys, refer to Terminology B846.

3.2 *Definitions:*

3.2.1 *bus bar, n*—includes material of solid rectangular or square cross section or a solid section with two plane parallel surfaces and round or other simple regularly shaped edges up to and including 12 in. in width and 0.090 in. and over in thickness.

3.2.2 *bus conductor stock, n*—a bar, rod, or shape of high conductivity copper used to make electrical conductors.

3.2.3 *bus rod, n*—includes solid round and regular polygons of six and eight sides.

3.2.4 *bus shapes, n*—a solid section other than regular rod, bar, plate, sheet, strip, or flat wire, that may be oval, half oval, half round, triangular, pentagonal, or of any special cross section furnished in straight lengths. Shapes shall not include tube and pipe or other hollow sections.

3.3 *Definitions of Terms Specific to This Standard:*

3.3.1 *orange peel, n*—the surface roughness resulting from working metal of large grain size. The surface is similar in texture to that of the outside surface of an orange.

### 4. General Requirements

4.1 The following sections of Specification B249/B249M are a part of this specification:

- 4.1.1 Terminology;
- 4.1.2 Materials and Manufacture;
- 4.1.3 Workmanship, Finish, and Appearance;
- 4.1.4 Sampling;
- 4.1.5 Number of Tests and Retests;
- 4.1.6 Test Methods;
- 4.1.7 Specimen Preparation;
- 4.1.8 Significance of Numerical Limits;
- 4.1.9 Inspection;
- 4.1.10 Rejection and Reheating;
- 4.1.11 Certification;

- 4.1.12 Test Reports; and
- 4.1.13 Packaging and Package Marking.

4.2 Identical sections in this specification supplement the referenced section.

### 5. Ordering Information

5.1 Include the following specified choices when placing orders for product under this specification, as applicable:

- 5.1.1 ASTM specification designation and year of issue;
- 5.1.2 Copper UNS No. (see 7.1 and Table 1);
- 5.1.3 Temper required (see 8.1 and Table 2);
- 5.1.4 Dimensions and form;
- 5.1.5 DELETED
- 5.1.6 Shapes: dimensional tolerances required and agreed upon (see 13.3);
- 5.1.7 Quantity: number of pounds, pieces, or footage required;
- 5.1.8 Length: stock or specific (see 13.5); and
- 5.1.9 When material is purchased for agencies of the U.S. Government (see Section 12).

5.2 The following options are available but may not be included unless specified at the time of placing of the order when required:

- 5.2.1 Heat identification or traceability details required,
- 5.2.2 Hydrogen embrittlement test,
- 5.2.3 Bend test,
- 5.2.4 DELETED,
- 5.2.5 DELETED,
- 5.2.6 Special packaging requirements,
- 5.2.7 Edges other than finished edges (see 6.2.1.2),
- 5.2.8 Edge contours other than square edge (see 13.7), and
- 5.2.9 Location for the determination of the Rockwell hardness (see 10.2.2).

### 6. Materials and Manufacture

6.1 *Material:*

6.1.1 The materials shall conform to the published compositional requirements of the Copper or Copper Alloy UNS No. designation specified in the ordering information.

6.1.2 In the event heat identification or traceability is required, the purchaser shall specify the details desired.

6.2 *Manufacture:*

6.2.1 *Edges:*

6.2.1.1 Bar shall be furnished with finished edges (see 13.7) unless otherwise specified at the time of order placement.

6.2.1.2 Bar may be furnished with sawed edges and deburred corners upon agreement between the manufacturer or supplier and the purchaser (see 5.2.7).

### 7. Chemical Composition

7.1 The specified copper shall conform to the chemical requirements prescribed in Table 1.

7.2 These specification limits do not preclude the possible presence of other elements. Limits for unnamed elements may be established and analysis required by agreement between the manufacturer or the supplier and the purchaser.

TABLE 1 Chemical Requirements

NOTE 1—If the type of silver-bearing copper is not specified (that is whether tough pitch, phosphorized, or oxygen-free), any one of the three types may be supplied at the option of the manufacturer.

Composition % Maximum (Unless shown as a range or minimum)						
Copper UNS No.	Copper (Incl. Silver)	Phosphorus	Silver	Oxygen	Tellurium	Tin
C10100	99.99 <sup>A</sup> min	<i>B</i>	<i>B</i>	<i>B</i>	<i>B</i>	<i>B</i>
C10200	99.95 <sup>C</sup> min	...	...	0.0010	...	...
C10300	99.95 <sup>C</sup> min	0.001–0.005	...	...	...	...
C10400 <sup>E</sup>	99.95 <sup>C</sup> min	...	8 <sup>F</sup>	0.0010	...	...
C10500 <sup>E</sup>	99.95 <sup>C</sup> min	...	10 <sup>F</sup>	0.0010	...	...
C10700 <sup>E</sup>	99.95 <sup>C</sup> min	...	25 <sup>F</sup>	0.0010	...	...
C10800	99.95 <sup>D</sup> min	0.005–0.012	...	...	...	...
C10920	99.90 min	...	...	0.02	...	...
C10930	99.90 min	...	13 <sup>F</sup>	0.02	...	...
C10940	99.90 min	...	25 <sup>F</sup>	0.02	...	...
C11000	99.90 min	...	...	<i>G</i>	...	...
C11020	99.90 min	...	...	<i>G</i>	...	...
C11300 <sup>H</sup>	99.90 min	...	8 <sup>F</sup>	<i>G</i>	...	...
C11400 <sup>H</sup>	99.90 min	...	10 <sup>F</sup>	<i>G</i>	...	...
C11500 <sup>H</sup>	99.90 min	...	16 <sup>F</sup>	<i>G</i>	...	...
C11600 <sup>H</sup>	99.90 min	...	25 <sup>F</sup>	<i>G</i>	...	...
C12000	99.90 min	0.004–0.012	...	...	...	...
C12200	99.90 min	0.015–0.040	...	...	...	...

<sup>A</sup> Copper value is determined by the difference between the impurity total and 100 %. The copper value is exclusive of Ag.  
<sup>B</sup> Impurity maximums in ppm of C10100 shall be: antimony 4, arsenic 5, bismuth 1, cadmium 1, iron 10, lead 5, manganese 0.5, nickel 10, oxygen 5, phosphorus 3, selenium 3, silver 25, sulfur 15, tellurium 2, tin 2, and zinc 1.  
<sup>C</sup> Copper value is determined by the difference between the impurity total and 100 %.  
<sup>D</sup> Copper (includes silver) + phosphorus, min.  
<sup>E</sup> C10400, C10500, and C10700 are oxygen-free coppers with the addition of a specified amount of silver. The compositions of these alloys are equivalent to C10200 plus the intentional addition of silver.  
<sup>F</sup> Values are minimum silver in Troy ounces per Avoirdupois ton (1 oz/ton is equivalent to 0.0034 %).  
<sup>G</sup> Oxygen and trace elements may vary depending on the process.  
<sup>H</sup> C11300, C11400, C11500, and C11600 are electrolytic tough-pitch copper with silver additions. The compositions of these alloys are equivalent to C11000 plus the intentional addition of silver.

8. Temper

8.1 Tempers available under this specification and as described in Classification B601 are as follows:

Standard	Temper Designation	Former
O60		soft anneal
H02		half hard
H04		hard

9. Physical Property Requirements

9.1 *Electrical Resistivity*—Bar, rod, and shapes of alloys Copper UNS Nos. C10100, C10200, C10300, C10400, C10500, C10700, C10920, C10930, C10940, C11000, C11020, C11300, C11400, C11500, C11600, and C12000 shall conform to the electrical resistivity limits prescribed in Table 2 for specified copper, temper, form, and size when determined in accordance with Test Method B193.

9.2 *Electrical Resistivity*—Unless otherwise specified in the contract or ordering information, the manufacturer has the option of using Test Method E1004 to determine conformance to the electrical resistivity limits prescribed in Table 2 for Copper UNS Nos. C10100, C10200, C10300, C10400, C10500, C10700, C10920, C10930, C10940, C11000, C11020, C11300, C11400, C11500, C11600, and C12000. In case of dispute, Test Method B193 shall be used.

10. Mechanical Property Requirements

10.1 *Tensile Requirements:*

10.1.1 The products shall conform to the tensile, yield, and elongation requirements of Table 2.

10.1.1.1 DELETED

10.2 *Rockwell Hardness:*

10.2.1 Rockwell hardness tests offer a quick and convenient method of checking copper of any temper for general conformity to the requirements of tensile strength. The approximate Rockwell hardness values for the specified tempers are given in Table 2 for general information and assistance in testing.

10.2.2 When specified at the time of order and as agreed to by the purchaser and supplier or manufacturer, the location for the determination of the Rockwell hardness may be specified.

11. Performance Requirements

11.1 *Bending Requirements:*

11.1.1 When specified in the contract or purchase order, for bar, bus bar, flat wire, and rod, test specimens shall withstand being bent cold (right way bend) through an angle as specified in Table 2 for the specified temper and size without fracture on the outside of the bent portion and with no evidence of slivers, cracks, orange peel, or similar surface defects being visible to the unaided eye.

11.1.2 The bend shall be made on a radius equal to the minimum cross-sectional dimension of the specimen, and this dimension shall be radial to the bend.

11.1.3 The axis of the bend shall be at an angle of 90° to the direction of rolling, drawing, or extrusion (right way bend).

TABLE 2 Mechanical (All Alloys) and Electrical Requirements<sup>A</sup> (Conductor Alloys Only)

Standard	Temper Designation	Former	Diameter or Distance Between Parallel Surfaces, in.	Tensile Strength, ksi, [MPa] <sup>B</sup>		Yield Strength, ksi, [MPa]	Elongation in 4 x Diameter or Thickness of Specimen Min. % <sup>D</sup>	Bend Test Angle of Bend °	Electrical Resistivity, <sup>E</sup> Max, Ω·g/m <sup>2</sup> at 20 °C [68 °F]				Rockwell Hardness F Scale, 60-kg Load, 1/16-in. Ball
				Min	Max	Min <sup>C</sup>			C10100	C10200, C10400, C10500, C10700, C10920, C10930, C10940, C11000, C11020, C11300, C11400, C11500, C11600	C10300	C12000	
O60	Soft anneal		Rod and bar:										
			All sizes	28 [195]	37 [255]	8 [55] <sup>C</sup>	25	180	0.15176	0.153 28	0.156 14	0.16661	50 max
H04	Hard		Rod:										
			Up to 3/8 [10] incl.	45 [310]	60 [410]	—	12	120	0.15585	0.157 87	0.15940	0.17031	—
			Over 3/8 [10] to 1 [25] incl.	40 [275]	55 [380]	—	12	120	0.15585	0.15737	0.15940	0.17031	80 min
			Over 1 [25] to 2 [50] incl.	35 [240]	50 [345]	—	15	120	0.15585	0.15737	0.15940	0.17031	75 min
			Over 2 [50] to 3 [75] incl.	33 [230]	48 [330]	—	15	120	0.15425	0.15577	0.15940	0.17031	65 min
			Over 3 [75]	30 [205]	48 [330]	—	15	120	0.15425	0.15577	0.15940	0.17031	—
H02	Half Hard		Bar:										
			Up to 3/8 [10] incl. thickness and up to 4 [110] incl. in width	37.5 [260]	50 [345]	—	10	120	0.15585	0.15737	0.15940	0.17031	80 min
			All other sizes	33 [230]	50 [345]	—	15	120	0.15425	0.15577	0.15940	0.17031	65 min
			Channels, angles and shapes	<sup>F</sup>	<sup>F</sup>	<sup>F</sup>	15	—	0.15425	0.15577		0.17031	—

<sup>A</sup> See 9.1.  
<sup>B</sup> ksi = 1000 psi.  
<sup>C</sup> Light-straightening operation is permitted.  
<sup>D</sup> In any case, a minimum gage length of 1 in. shall be used.  
<sup>E</sup> See Appendix X1.  
<sup>F</sup> Yield and tensile strength shall meet the requirements of the O60 temper.

11.1.4 Edgewise and wrong way bend test requirements for bar or bus bar shall be by agreement between the manufacturer or supplier and the purchaser.

11.2 Microscopical Examination:

11.2.1 Copper UNS Nos. C10100, C10200, C10300, C10400, C10500, C10700, C10800, and C12000 shall be substantially free of cuprous oxide as determined by Procedure A, Microscopical Examination, of Test Methods B577.

11.2.2 In lieu of the Microscopic examination for copper C10100, C10200, C10300, C10400, C10500, C10700, C10800 the manufacturer has the option to determine the actual oxygen content of the copper in the final size. If the oxygen level is equal to or less than 10 ppm, then it is considered free of cuprous oxide. For Copper C12000 when phosphorus content is within the specification (0.004 and 0.012 %) it should be considered substantially free of cuprous oxide. In case of dispute, testing shall be in accordance with Test Method E2575.

11.2.3 In case of dispute, testing shall be in accordance with Procedure C, Closed Bend Test, of Test Methods B577.

11.3 Embrittlement Test:

11.3.1 When specified in the contract or purchase order, Copper UNS Nos. C10100, C10200, C10300, C10400, C10500, C10700, C10800, and C12000 shall pass the embrittlement test described in Procedure B, Microscopical Examination of Thermally Treated Specimens, in Test Methods B577.

11.3.2 In case of dispute, testing shall be in accordance with Procedure C, Closed Bend Test, of Test Methods B577.

12. Orders for U.S. Government Agencies

12.1 Orders for agencies of the U.S. Government shall conform to the special government requirements stipulated in the Supplemental Requirements section.

13. Dimensions, Mass, and Permissible Variations

13.1 The dimensions and tolerances for material manufactured under this specification shall be as specified in the following tables:

13.2 Diameter or Distance Between Parallel Surfaces:

13.2.1 Rod: Round, Hexagonal, Octagonal—See Table 3.

**TABLE 3 Diameter Tolerances for Cold-Drawn Rod (H04 and O60 Tempers)**

Diameter or Distance Between Parallel Surfaces, in. [mm]	Tolerances, Plus and Minus, <sup>A</sup> in. [mm]	
	Round	Hexagonal or Octagonal
Up to 0.150 [3.8] incl.	0.0013 [0.035]	0.0025 [0.06]
Over 0.150 [3.8] to 0.500 [12] incl.	0.0015 [0.04]	0.003 [0.08]
Over 0.500 [12] to 1.00 [25] incl.	0.002 [0.05]	0.004 [0.10]
Over 1.00 [25] to 2.00 [50] incl.	0.0025 [0.06]	0.005 [0.13]
Over 2.00 [50]	0.15 <sup>B</sup>	0.30 <sup>B</sup>

<sup>A</sup> When tolerances are specified as all plus or all minus, double the values given.

<sup>B</sup> Percent of specified diameter or distance between parallel surfaces expressed to the nearest 0.001 in. [0.025 mm].

**TABLE 4 Thickness Tolerances for Drawn or Rolled Rectangular and Square Bar Plus and Minus,<sup>A</sup> in. [mm]**

Thickness	Width, in. [mm]			
	2 [50] and Under	Over 2 [50] to 4 [100] incl.	Over 4 [100] to 8 [200] incl.	Over 8 [200] to 12 [300] incl.
Up to 0.500 [13], incl.	0.003 [0.08]	0.004 [0.10]	0.0045 [0.11]	0.0055 [0.14]
Over 0.500 [13] to 1.000 [25], incl.	0.004 [0.10]	0.0045 [0.11]	0.005 [0.13]	0.006 [0.15]
Over 1.000 [25] to 2.000 [50], incl.	0.0045 [0.11]	0.005 [0.13]	0.006 [0.15]	...

<sup>A</sup> When tolerances are specified as all plus or all minus, double the values given.

**TABLE 5 Thickness Tolerances for Sawed Edge, Deburred Corner Rectangular and Square Bar, Plus and Minus,<sup>A</sup> in. [mm] for Widths Given in Inches [mm]**

Thickness	2 [50] and Under incl.	Over 2 [50] to 4 [100] incl.	Over 4 [100] to 8 [200] incl.	Over 8 [200] to 12 [300] incl.
Up to 0.250 [6], incl.	0.0025 [0.06]	0.003 [0.08]	0.0035 [0.09]	0.005 [0.13]
Over 0.250 [6] to 0.375 [10] incl.	0.003 [0.08]	0.004 [0.10]	0.0045 [0.11]	0.005 [0.13]
Over 0.375 [10] to 0.500 [13] incl.	0.0035 [0.09]	0.0045 [0.11]	0.005 [0.13]	0.006 [0.15]
Over 0.500 [13] to 0.750 [19] incl.	0.0055 [0.14]	0.0055 [0.14]	0.0055 [0.14]	0.007 [0.18]
Over 0.750 [19] to 1.000 [25] incl.	0.007 [0.18]	0.007 [0.18]	0.007 [0.18]	0.009 [0.23]
Over 1.000 [25] to 1.500 [38] incl.	0.015 [0.38]	0.020 [0.50]	0.022 [0.55]	0.025 [0.60]
Over 1.500 [38] to 2.000 [50] incl.	0.020 [0.50]	0.024 [0.60]	0.026 [0.65]	0.030 [0.75]

<sup>A</sup> When tolerances are specified as all plus or all minus, double the values given.

**TABLE 6 Width Tolerances for Drawn or Rolled Rectangular and Square Bar**

Width, in. [mm]	Tolerances, Plus and Minus, <sup>A</sup> in. [mm]
2 [50] and under	0.008 [0.2]
Over 2 [50] to 4 [100], incl.	0.012 [0.3]
Over 4 [100] to 12 [310] incl.	0.30 <sup>B</sup>

<sup>A</sup> When tolerances are specified as all plus or all minus, double the values given.

<sup>B</sup> Percent of specified width expressed to the nearest 0.001 in. [0.01 mm].

**TABLE 8 Length Tolerances for Rod, Bar, and Shapes (Full-Length Pieces Specific and Stock Lengths with or without Ends)**

Length Classification	Tolerances, All Plus, in. [mm] (Applicable Only to Full-Length Pieces)
Specific lengths	
Up to 6 ft. [1800 mm]	1/8 [3]
Over 6 to 15 ft. [1800 to 4500 mm]	1/4 [6]
Over 15 ft. [4500 mm]	1/2 [13]
Specific lengths with ends	1 [25]
Stock lengths with or without ends	1 [25]

**TABLE 7 Width Tolerances for Sawed Edge with Deburred Corner Rectangular and Square Bar, Plus and Minus, in. [mm]<sup>A</sup>**

Thickness	Width, in. [mm]	
	12 [300] and under incl.	Over 12 [300]
Up to 1.500 [40], incl.	1/32 [0.8]	1/16 [1.6]
Over 1.500 [40]	1/16 [1.6]	1/16 [1.6]

<sup>A</sup> When tolerances are specified as all plus or all minus, double the values given.

13.2.2 Bar: Rectangular and Square:

13.2.2.1 Thickness Tolerances for Rectangular and Square Bar—See Table 4 for rolled or drawn edges and Table 5 for sawed edges with deburred corners.

13.2.2.2 Width Tolerances for Rectangular and Square Bar—See Table 6 for rolled or drawn edges and Table 7 for sawed edges with deburred corners.

13.3 Shapes—The dimensional tolerances of shapes shall be as agreed upon by the manufacturer or supplier and the purchaser and shall be specified in the order.

13.4 Coils—The coil size shall be as agreed upon between the manufacturer or supplier and the purchaser and shall be specified in the order.

TABLE 9 Schedule of Lengths (Specific and Stock) with Ends

Diameter or Distance Between Parallel Surfaces for Round Hexagonal, Octagonal Rod and Square Bar, in. [mm]	Rectangular Bar Area, <sup>A</sup> in <sup>2</sup> [mm <sup>2</sup> ]	Nominal Length, ft [mm]	Shortest Permissible Length <sup>B</sup> % of Nominal Length	Maximum Permissible Weight of Ends, % of Lot Weight
½ [13] and under	0.250 [160] and under	6 to 14 [1800 to 4300] incl.	75	20
Over ½ to 1 [13 to 25] incl.	Over 0.250 to 1 [160 to 650] incl.	6 to 14 [1800 to 4300] incl.	70	30
Over 1 to 1½ [25 to 40] incl.	Over 1 to 2.25 [650 to 1450] incl.	6 to 12 [1800 to 3600] incl.	60	40
Over 1½ to 2 [40 to 50] incl.	Over 2.25 to 4 [1450 to 2600] incl.	6 to 12 [1800 to 3600] incl.	50	45
Over 2 to 3 [50 to 75] incl.	Over 4 to 9 [2600 to 5000] incl.	6 to 10 [1800 to 3000] incl.	40	50

<sup>A</sup> Width times thickness, disregarding any rounded corner or edges.

<sup>B</sup> Expressed to the nearest ½ ft [100 mm].

TABLE 10 Straightness Tolerances Applicable to Any Longitudinal Surface or Edge

	Maximum Curvature (Depth of Arc), in. [mm]	Portion of Total Length in Which Depth of Arc Is Measured, in. [mm]
Rod	½ [13]	120 [3000]
Shapes	½ [13]	72 [1800]
Bar (except half hard rectangular bar listed in following line)	¼ [6]	60 [1500]
Half hard rectangular bar ⅛ to ⅝ in. [3 to 15 mm] incl., in thickness, having widths ranging from 2 to 6 in. [50 to 150], incl.	⅛ [3]	96 [2400]

TABLE 11 Radius for Square Corners

Specified Thickness, in. [mm]	Maximum Radius Permissible for Square Corners, in. [mm]
Up to ⅜ [5] incl.	¼ [0.4]
Over ⅜ to 1 [5 to 25] incl.	⅜ [0.8]
Over 1 [25]	⅜ [1.6]

### 13.5 Length:

13.5.1 *Specified Length*—When exact lengths are ordered, the lengths shall be not less than the ordered length and shall not exceed it by more than the amount specified in Table 8.

13.5.2 *Stock Lengths*—For material ordered in stock lengths, full-length pieces shall be not less than the designated length and shall not exceed it by more than 1 in. Short lengths may be included as prescribed in Table 9.

13.6 *Straightness*—Unless otherwise specified in the contract or purchase order, the material shall be supplied in straight lengths. The deviation from absolute straightness of any longitudinal surface or edge shall not exceed the limitations prescribed in Table 10.

13.6.1 To determine compliance with this section, rod and bar shall, in case of disagreement, be checked by the following method:

13.6.1.1 Place the rod or bar on a level table so that the arc or departure from straightness is horizontal. Measure the maximum depth of arc to the nearest ⅓<sub>2</sub> in. [0.8 mm] using a steel scale and a straight edge.

### 13.7 Edge Contours:

13.7.1 *Angles*—All polygonal sections shall have substantially exact angles and sharp corners.

13.7.2 *Square Corners*—Unless otherwise specified in the contract or purchase order, bar shall be finished with commercially square corners with the maximum permissible radius shown in Table 11.

13.7.3 *Rounded Corners*—When specified in the contract or purchase order, bar may be finished with corners rounded as shown in Fig. 1 to a quarter circle with a radius as shown in Table 12. The tolerance on the radius shall be ±25 %.

13.7.4 *Rounded Edge*—When specified in the contract or purchase order, bar may be finished with edges rounded as shown in Fig. 2, with a radius of curvature as shown in Table 13.

13.7.5 *Full Rounded Edge*—When specified in the contract or purchase order, bar may be finished with substantially uniform round edges, the radius of curvature being approximately one half the thickness of the product as shown in Fig. 3, but in no case to exceed one half the thickness of the product by more than 25 %.

13.7.6 *Shapes*—Products with edge or corner contours other than described in 13.7.1 – 13.7.5 are classified as shapes.

NOTE 2—For the purpose of determining conformance with the dimensional requirements prescribed in this specification, any measured value outside the specified limiting values for any dimension may be cause for rejection.

## 14. Specimen Preparation

14.1 *Microscopical Examination*—Specimen preparation shall be in accordance with Procedure A of Test Methods B577.

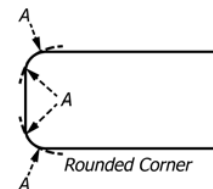

NOTE 1—The arc shall not necessarily be tangent at points, A, but the product shall be commercially free from sharp, rough, or projecting edges.

FIG. 1 Rounded Corners

**TABLE 12 Radius for Rounded Corners**

Specified Thickness, in. [mm]	Nominal Radius of Corners, in. [mm]	
	For Widths Up to and Including 2x Thickness	For Widths More Than 2x Thickness
Up to 1/8 [2], incl.	1/64 [0.4]	full rounded edges as given in 13.7.5
Over 1/8 to 3/16 [2 to 6], incl.	1/32 [0.8]	1/32 [0.8]
Over 3/16 to 1 [6 to 25], incl.	1/16 [1.6]	1/16 [1.6]
Over 1 [25]	1/8 [3]	1/8 [3]

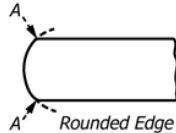

NOTE 1—The arc shall be substantially symmetrical with the axis of the product. The corners, A, will usually be sharp, but shall not have rough or projecting edges.

**FIG. 2 Rounded Edge**

**TABLE 13 Radius for Rounded Edge**

Specified Thickness, in. [mm]	Nominal Radius of Rounded Edge, in. [mm]	Tolerance on Radius, Plus and Minus, in. [mm]
Up to 3/16 [5], incl.	1/4 x thickness	1/2 x thickness
Over 3/16 [5]	1/4 x thickness	1/4 x thickness

**15. Test Methods**

15.1 Refer to Specification B249/B249M for the appropriate mechanical test method.

15.2 In cases of disagreement, test methods for chemical analysis shall be subject to agreement between the manufacturer or supplier and the purchaser. The following table is a list

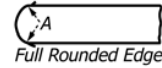

NOTE 1—The arc shall not necessarily be tangent at points, A, but shall be substantially symmetrical with the axis of the product, and the product shall be commercially free from sharp, rough, or projecting edges.

**FIG. 3 Full Rounded Edge**

of published methods, some of which may no longer be viable, which along with others not listed, may be used subject to agreement.

Element	ASTM Test Method
Copper	E53
Phosphorus	E62
Selenium	Refer to Annex, Specification B216
Silver	E478
Tellurium	Refer to Annex, Specification B216

15.2.1 For Copper No. C10100, refer to the Annex of Specification B170 for test methods.

15.2.2 Test method(s) for the determination of element(s) resulting from contractual or purchaser order agreement shall be as agreed upon between the manufacturer or supplier and the purchaser.

**16. Certification**

16.1 The certification and test report requirements of Specification B249/B249M are mandatory.

**17. Keywords**

17.1 bar; bus bar; copper; electrical conductors; embrittlement test; rod; shapes; UNS No. C10100; UNS No. C10200; UNS No. C10300; UNS No. C10400; UNS No. C10500; UNS No. C10700; UNS No. C10920; UNS No. C10930; UNS No. C10940; UNS No. C11000; UNS No. C11020; UNS No. C11300; UNS No. C11400; UNS No. C11500; UNS No. C11600; UNS No. C10800; UNS No. C12000; UNS No. C12200

**SUPPLEMENTARY REQUIREMENTS**

The following supplementary requirements shall apply only when specified by the purchaser in the inquiry, contract, or order, for agencies of the U.S. Government.

**S1. Referenced Documents**

S1.1 The following documents of the issue in effect on date of material purchase form a part of this specification to the extent referenced herein:

S1.1.1 *Federal Standards:*

Fed. Std. No. 102 Preservation, Packaging and Packing Levels

Fed. Std. No. 123 Marking for Shipment (Civil Agencies)

Fed. Std. No. 185 Identification Marking of Copper and Copper-Base Alloy Mill Products

S1.1.2 *Military Standards:*

MIL-STD-105 Sampling Procedures and Table for Inspection by Attributes

MIL-STD-129 Marking for Shipment and Storage

S1.1.3 *Military Specification:*

NOTE 3—MIL-C-3993, Packaging of Copper and Copper-Base Alloy Mill Products, has been withdrawn and replaced by Practice B900.

**S2. Quality Assurance**

S2.1 *Responsibility for Inspection*—Unless otherwise specified in the contract or purchase order, the manufacturer is responsible for the performance of all inspection and test requirements specified. Except as otherwise specified in the contract or purchase order, the manufacturer may use his own or any other suitable facilities for the performance of the inspection and test requirements unless disapproved by the

purchaser at the time the order is placed. The purchaser shall have the right to perform any of the inspections or tests set forth when such inspections and tests are deemed necessary to ensure that the material conforms to prescribed requirements.

### S3. Identification Marking

S3.1 All material shall be properly marked for identification in accordance with Fed. Std. No. 185 except that the ASTM specification number and the alloy number shall be used.

### S4. Preparation for Delivery

S4.1 *Preservation, Packaging, Packing:*

S4.1.1 *Military Agencies*—The material shall be separated by size, composition, grade or class and shall be preserved and packaged, Level A or B as specified in the contract or purchase order, in accordance with the requirements of Practice B900.

S4.1.2 *Civil Agencies*—The requirements of Fed. Std. No. 102 shall be referenced for definitions of the various levels of packaging protection.

S4.2 *Marking:*

S4.2.1 *Military Agencies*—In addition to any special marking required by the contract or purchase order, marking for shipment shall be in accordance with MIL-STD-129.

S4.2.2 *Civil Agencies*—In addition to any special marking required by the contract or purchase order, marking for shipment shall be in accordance with Fed. Std. No. 123.

## APPENDIX

### (Nonmandatory Information)

### X1. RESISTIVITY

TABLE X1.1 Resistivity Relationships

Conductivity at 68 °F, %	101.0	100.0	99.37	98.40	98.35	98.16	97.40	96.16	92.20
$\Omega\text{-g/m}^2$	0.151 76	0.153 28	0.15425	0.155 77	0.15585	0.156 14	0.157 37	0.159 40	0.16661
$\Omega\text{-lb/mile}^2$	866.53	875.20	880.75	889.42	889.88	891.60	898.55	910.15	951.31
$\Omega\text{-cmil/ft}$	10.268	10.371	10.437	10.539	10.54	10.565	10.648	10.785	11.273
$\Omega\text{-mm}^2/\text{m}$	0.017 070	0.017 241	0.017350	0.017 521	0.017530	0.017 564	0.017 701	0.017 930	.018740
$\mu\Omega\text{-in.}$	0.672 07	0.678 79	0.68309	0.689 81	0.69018	0.691 51	0.696 90	0.705 90	0.73782
$\mu\Omega\text{-cm}$	1.7070	1.7241	1.7350	1.7521	1.7530	1.7564	1.7701	1.7930	1.8740

X1.1 “Resistivity” is used in place of “conductivity.” The value of 0.153 28  $\Omega\text{-g/m}^2$  at 20 °C [68 °F] is the international standard for the resistivity of annealed copper equal to 100 % conductivity. This term means that a wire 1 m in length and weighing 1 g would have a resistance of 0.153 28  $\Omega$ . This is equivalent to a resistivity value of 875.20  $\Omega\text{-lb/mile}^2$ , which signifies the resistance of a wire 1 mile in length weighing 1 lb. It is also equivalent, for example, to 1.7241  $\mu\Omega\text{/cm}$  of length of a bar 1  $\text{cm}^2$  in cross section. A complete discussion of this

subject is contained in *NBS Handbook 100* of the National Institute of Standards and Technology. Relationships that may be useful in connection with the values of resistivity prescribed in this specification are as shown in Table X1.1, each column containing equivalent expressions at 20 °C [68 °F]:

ASMENORMDOC.COM : Click to view the full PDF of ASME BPVC.II.B (ASME BPVC Section II part B) 2025

INTENTIONALLY LEFT BLANK

## SPECIFICATION FOR ALUMINUM AND ALUMINUM-ALLOY SHEET AND PLATE



**SB-209/SB-209M**



(25)

(Identical with ASTM Specification B209/B209M-21a except for deletion of paras. 4.2.4, 4.2.8, 9.1.1, Note G from Table 2, Note H from Table 3, Note N from Table 4, Note M from Table 5; revision of para. 12.1; revision of paras. 17.1, 17.2, and 22.1 to make certification and test reports mandatory.)

*ASME SB-209/SB-209M replaces paras. 4.2.4 and 4.2.8 of ASTM B209/B209M with the following:*

4.2.4 DELETED

4.2.8 DELETED

*ASME SB-209/SB-209M, Table 2 replaces Note G of ASTM B209/B209M, Table 2 with the following:*

<sup>G</sup>DELETED

*ASME SB-209/SB-209M, Table 3 replaces Note H of ASTM B209/B209M, Table 3 with the following:*

<sup>H</sup>DELETED

*ASME SB-209/SB-209M replaces para. 9.1.1 of ASTM B209/B209M with the following:*

9.1.1 DELETED

*ASME SB-209/SB-209M, Table 4 replaces Note N of ASTM B209/B209M, Table 4 with the following:*

<sup>N</sup>DELETED

ASME SB-209/SB-209M, Table 5 replaces Note M of ASTM B209/B209M, Table 5 with the following:

<sup>M</sup>DELETED

ASME SB-209/SB-209M replaces para. 12.1 of ASTM B209/B209M with the following:

12.1 *Limits*—Sheet and plate shall be capable of being bent cold through an angle of 180° around a pin having a diameter equal to  $N$  times the thickness of the sheet or plate without cracking, the value of  $N$  being as prescribed in Table 2, Table 3, Table 4, and Table 5 for the different alloys, tempers, and thicknesses.

ASME SB-209/SB-209M replaces paras. 17.1, 17.2, and 22.1 of ASTM B209/B209M with the following:

17.1 Plate 0.500 to 4.500 in. [12.50 through 115.00 mm] in thickness and up to 2000 lb [1000 kg] in maximum weight in alloys 2014, 2024, 2124, 2219, and 7075, both bare and Alclad where applicable, shall be tested in accordance with Practice B594 to the discontinuity acceptance limits of Table 9 and Table 10.

17.2 Plate 0.500 in. [12.50 mm] in thickness and greater for ASME pressure vessel applications in alloys 1060, 1100, 3003, Alclad 3003, 3004, Alclad 3004, 5052, 5083, 5086, 5154, 5254, 5454, 5456, 6061, and Alclad 6061 shall be tested in accordance with Test Method B548. In such cases, the material will be subject to rejection if the following limits are exceeded unless it is determined by the purchaser that the area of the plate containing significant discontinuities will be removed during the subsequent fabrication process or that the plate may be repaired by welding:

22.1 The producer or supplier shall furnish to the purchaser a certificate stating that each lot has been sampled, tested, and inspected in accordance with this specification, and has met the requirements. A report of the test results shall be furnished.



Designation: B209/B209M – 21a

## Standard Specification for Aluminum and Aluminum-Alloy Sheet and Plate<sup>1</sup>

This standard is issued under the fixed designation B209/B209M; the number immediately following the designation indicates the year of original adoption or, in the case of revision, the year of last revision. A number in parentheses indicates the year of last reapproval. A superscript epsilon ( $\epsilon$ ) indicates an editorial change since the last revision or reapproval.

*This standard has been approved for use by agencies of the U.S. Department of Defense.*

### 1. Scope\*

1.1 This specification<sup>2</sup> covers aluminum and aluminum-alloy flat sheet, coiled sheet, and plate in the alloys (Note 1) and tempers shown in Tables 2, 3, 4, and 5, and in the following finishes:

1.1.1 Plate in all alloys and sheet in heat-treatable alloys: mill finish.

1.1.2 Sheet in nonheat-treatable alloys: mill finish, one-side bright mill finish, standard one-side bright finish, and standard two-sides bright finish.

1.2 Alloy and temper designations are in accordance with ANSI H35.1/H35.1M. The equivalent Unified Numbering System alloy designations are those of Table 1 preceded by A9, for example, A91100 for aluminum 1100 in accordance with Practice E527.

NOTE 1—Throughout this specification, use of the term *alloy* in the general sense includes aluminum as well as aluminum alloy.

NOTE 2—See Specification B632/B632M for tread plate.

NOTE 3—See Specification B928/B928M for 5xxx-H116 and 5xxx-H321 aluminum alloys containing 3 % or more nominal magnesium and intended for marine service and similar environments. Other alloy-temper products listed in this specification, which do not require the additional corrosion testing/capability called out in Specification B928/B928M, may be suitable for marine and similar environment applications.

1.3 For acceptance criteria for inclusion of new aluminum and aluminum alloys in this specification, see Annex A2.

1.4 The values stated in either SI units or inch-pound units are to be regarded separately as standard. The values stated in each system are not necessarily exact equivalents; therefore, to ensure conformance with the standard, each system shall be used independently of the other, and values from the two systems shall not be combined.

1.5 *This standard does not purport to address all of the safety concerns, if any, associated with its use. It is the*

<sup>1</sup> This specification is under the jurisdiction of ASTM Committee B07 on Light Metals and Alloys and is the direct responsibility of Subcommittee B07.03 on Aluminum Alloy Wrought Products.

Current edition approved Dec. 1, 2021. Published January 2022. Originally approved in 1946. Last previous edition approved in 2021 as B209/B209M – 21. DOI: 10.1520/B0209\_B0209M-21A.

<sup>2</sup> For ASME Boiler and Pressure Vessel Code applications see related Specification SB-209 in Section II of that Code.

*responsibility of the user of this standard to establish appropriate safety, health, and environmental practices and determine the applicability of regulatory limitations prior to use.*

1.6 *This international standard was developed in accordance with internationally recognized principles on standardization established in the Decision on Principles for the Development of International Standards, Guides and Recommendations issued by the World Trade Organization Technical Barriers to Trade (TBT) Committee.*

### 2. Referenced Documents

2.1 The following documents of the issue in effect on date of material purchase form a part of this specification to the extent referenced herein:

#### 2.2 ASTM Standards:<sup>3</sup>

- B548 Test Method for Ultrasonic Inspection of Aluminum-Alloy Plate for Pressure Vessels
- B557 Test Methods for Tension Testing Wrought and Cast Aluminum- and Magnesium-Alloy Products
- B557M Test Methods for Tension Testing Wrought and Cast Aluminum- and Magnesium-Alloy Products (Metric)
- B594 Practice for Ultrasonic Inspection of Aluminum-Alloy Wrought Products
- B632/B632M Specification for Aluminum-Alloy Rolled Tread Plate
- B660 Practices for Packaging/Packing of Aluminum and Magnesium Products
- B666/B666M Practice for Identification Marking of Aluminum and Magnesium Products
- B881 Terminology Relating to Aluminum- and Magnesium-Alloy Products
- B918/B918M Practice for Heat Treatment of Wrought Aluminum Alloys
- B928/B928M Specification for High Magnesium Aluminum-Alloy Products for Marine Service and Similar Environments
- B947 Practice for Hot Rolling Mill Solution Heat Treatment

<sup>3</sup> For referenced ASTM standards, visit the ASTM website, [www.astm.org](http://www.astm.org), or contact ASTM Customer Service at [service@astm.org](mailto:service@astm.org). For *Annual Book of ASTM Standards* volume information, refer to the standard's Document Summary page on the ASTM website.

for Aluminum Alloy Plate

B985 Practice for Sampling Aluminum Ingots, Billets, Castings and Finished or Semi-Finished Wrought Aluminum Products for Compositional Analysis

E29 Practice for Using Significant Digits in Test Data to Determine Conformance with Specifications

E34 Test Methods for Chemical Analysis of Aluminum and Aluminum-Base Alloys (Withdrawn 2017)<sup>4</sup>

E290 Test Methods for Bend Testing of Material for Ductility

E527 Practice for Numbering Metals and Alloys in the Unified Numbering System (UNS)

E607 Test Method for Atomic Emission Spectrometric Analysis Aluminum Alloys by the Point to Plane Technique Nitrogen Atmosphere (Withdrawn 2011)<sup>4</sup>

E716 Practices for Sampling and Sample Preparation of Aluminum and Aluminum Alloys for Determination of Chemical Composition by Spark Atomic Emission Spectrometry

E1004 Test Method for Determining Electrical Conductivity Using the Electromagnetic (Eddy Current) Method

E1251 Test Method for Analysis of Aluminum and Aluminum Alloys by Spark Atomic Emission Spectrometry

G34 Test Method for Exfoliation Corrosion Susceptibility in 2XXX and 7XXX Series Aluminum Alloys (EXCO Test)

G47 Test Method for Determining Susceptibility to Stress-Corrosion Cracking of 2XXX and 7XXX Aluminum Alloy Products

#### 2.3 ANSI Standards:<sup>5</sup>

H35.1/H35.1M American National Standard Alloy and Temper Designation Systems for Aluminum

H35.2 American National Standard Dimensional Tolerances for Aluminum Mill Products

H35.2M American National Standard Dimensional Tolerances for Aluminum Mill Products (Metric)

#### 2.4 ISO Standards:<sup>6</sup>

ISO 209-1 Wrought aluminium and aluminium alloys – Chemical composition and forms of products – Part 1: Chemical composition

ISO 2107 Aluminium and aluminium alloys – Wrought products – Temper designations

ISO 6361-2 Wrought aluminium and aluminium alloys – Sheets, strips and plates – Part 2: Mechanical properties

#### 2.5 AMS Specification:<sup>7</sup>

AMS2772 Heat Treatment of Aluminum Alloy Raw Materials

#### 2.6 CEN Standard:<sup>8</sup>

CEN - EN 14242 Aluminium and aluminium alloys – Chemical analysis – Inductively coupled plasma optical

emission spectral analysis

### 3. Terminology

#### 3.1 Definitions:

3.1.1 Refer to Terminology B881 for definitions of product terms used in this specification.

#### 3.2 Definitions of Terms Specific to This Standard:

3.2.1 *capable of*—the term *capable of*, as used in this specification, means that the test need not be performed by the producer of the material; however, should testing by the purchaser establish that the material does not meet these requirements, the material shall be subject to rejection.

### 4. Ordering Information

4.1 Orders for material to this specification shall include the following information:

4.1.1 This specification designation (which includes the number, the year, and the revision letter, if applicable).

4.1.2 Quantity in pieces or pounds.

4.1.3 Alloy (7.1).

4.1.4 Temper (9.1).

4.1.5 Finish for sheet in nonheat-treatable alloys (Section 1).

4.1.6 For sheet, whether flat or coiled.

4.1.7 Dimensions (thickness, width, and length or coil size).

4.1.8 Tensile property limits and dimensional tolerances for sizes not covered in Table 2, Table 3, Table 4, or Table 5 of this specification or in ANSI H35.2 [H35.2M].

4.2 Additionally, orders for material meeting the requirements of this specification shall include the following information when required by the purchaser:

4.2.1 Whether a supply of one of the pairs of tempers where shown in Table 2 or Table 3, (H14 or H24) or (H34 or H24), is specifically excluded (Table 2 and Table 3, Footnote C).

4.2.2 Whether heat treatment in accordance with Practice B918/B918M is required (8.2).

4.2.3 Whether solution heat treatment using the hot rolling mill is acceptable (8.3).

4.2.4 Whether bend tests are required (12.1).

4.2.5 Whether testing for stress-corrosion cracking resistance of alloy 2124-T851, 2219-T851, or 2219-T87 is required (13.1).

4.2.6 Whether ultrasonic inspection for aerospace or pressure vessels applications is required (Section 17).

4.2.7 Whether inspection or witness of inspection and tests by the purchaser's representative is required prior to material shipment (18.1).

4.2.8 Whether certification is required (Section 22).

4.2.9 Whether there are exceptions to identification marking as provided in B666/B666M (20.1).

4.2.10 Whether Practices B660 apply and, if so, the levels of preservation, packaging, and packing required (21.3).

4.2.11 For sheet and plate with tensile properties having more than one test direction shown in Table 2, Table 3, Table 4, and Table 5, whether tensile testing should be in a direction other than the direction specified in Test Method B557 or B557M (Subsection 9.4).

<sup>4</sup> The last approved version of this historical standard is referenced on [www.astm.org](http://www.astm.org).

<sup>5</sup> Available from Aluminum Association, 1400 Crystal Dr., Suite 430, Arlington, VA 22202, <http://www.aluminum.org>.

<sup>6</sup> Available from International Organization for Standardization (ISO), ISO Central Secretariat, Chemin de Blandonnet 8, CP 401, 1214 Vernier, Geneva, Switzerland, <https://www.iso.org>.

<sup>7</sup> Available from SAE International (SAE), 400 Commonwealth Dr., Warrendale, PA 15096, <http://www.sae.org>.

<sup>8</sup> Available from European Committee for Standardization (CEN), Avenue Marnix 17, B-1000, Brussels, Belgium, <http://www.cen.eu>.

TABLE 1 Chemical Composition Limits<sup>A,B,C,M</sup>

Alloy	Silicon	Iron	Copper	Manganese	Magnesium	Chromium	Zinc	Titanium	Other Elements <sup>D</sup>		Aluminum
									Each	Total <sup>E</sup>	
1060	0.25	0.35	0.05	0.03	0.03	...	0.05	0.03	0.03 <sup>F</sup>	...	99.60 min <sup>G</sup>
1100	0.95 Si + Fe		0.05–0.20	0.05	...	...	0.10	...	0.05	0.15	99.00 min <sup>G</sup>
1230 <sup>H</sup>	0.70 Si + Fe		0.10	0.05	0.05	...	0.10	0.03	0.03 <sup>F</sup>	...	99.30 min <sup>G</sup>
2014	0.50–1.2	0.7	3.9–5.0	0.40–1.2	0.20–0.8	0.10	0.25	0.15	0.05	0.15	remainder
Alclad 2014					2014 clad with 6003						
2024	0.50	0.50	3.8–4.9	0.30–0.9	1.2–1.8	0.10	0.25	0.15	0.05	0.15	remainder
Alclad 2024					2024 clad with 1230						
2124	0.20	0.30	3.8–4.9	0.30–0.9	1.2–1.8	0.10	0.25	0.15	0.05	0.15	remainder
2219	0.20	0.30	5.8–6.8	0.20–0.40	0.02	...	0.10	0.02–0.10	0.05 <sup>I</sup>	0.15 <sup>I</sup>	remainder
Alclad 2219					2219 clad with 7072						
3003	0.6	0.7	0.05–0.20	1.0–1.5	...	...	0.10	...	0.05	0.15	remainder
Alclad 3003					3003 clad with 7072						
3004	0.30	0.7	0.25	1.0–1.5	0.8–1.3	...	0.25	...	0.05	0.15	remainder
Alclad 3004					3004 clad with 7072						
3005	0.6	0.7	0.30	1.0–1.5	0.20–0.6	0.10	0.25	0.10	0.05	0.15	remainder
3105	0.6	0.7	0.30	0.30–0.8	0.20–0.8	0.20	0.40	0.10	0.05	0.15	remainder
5005	0.30	0.7	0.20	0.20	0.50–1.1	0.10	0.25	...	0.05	0.15	remainder
5010	0.40	0.7	0.25	0.10–0.30	0.20–0.6	0.15	0.30	0.10	0.05	0.15	remainder
5050	0.40	0.7	0.20	0.10	1.1–1.8	0.10	0.25	...	0.05	0.15	remainder
5052	0.25	0.40	0.10	0.10	2.2–2.8	0.15–0.35	0.10	...	0.05	0.15	remainder
5059	0.45	0.50	0.25	0.6–1.2	5.0–6.0	0.25	0.40–0.9	0.20	0.05 <sup>J</sup>	0.15	remainder
5083	0.40	0.40	0.10	0.40–1.0	4.0–4.9	0.05–0.25	0.25	0.15	0.05	0.15	remainder
5086	0.40	0.50	0.10	0.20–0.7	3.5–4.5	0.05–0.25	0.25	0.15	0.05	0.15	remainder
5154	0.25	0.40	0.10	0.10	3.1–3.9	0.15–0.35	0.20	0.20	0.05	0.15	remainder
5252	0.08	0.10	0.10	0.10	2.2–2.8	...	0.05	...	0.03 <sup>F</sup>	0.10 <sup>F</sup>	remainder
5254	0.45 Si + Fe		0.05	0.01	3.1–3.9	0.15–0.35	0.20	0.05	0.05	0.15	remainder
5454	0.25	0.40	0.10	0.50–1.0	2.4–3.0	0.05–0.20	0.25	0.20	0.05	0.15	remainder
5456	0.25	0.40	0.10	0.50–1.0	4.7–5.5	0.05–0.20	0.25	0.20	0.05	0.15	remainder
5457	0.08	0.10	0.20	0.15–0.45	0.8–1.2	...	0.05	...	0.03 <sup>F</sup>	0.10 <sup>F</sup>	remainder
5657	0.08	0.10	0.10	0.03	0.6–1.0	...	0.05	...	0.02 <sup>K</sup>	0.05 <sup>K</sup>	remainder
5754	0.40	0.40	0.10	0.50 <sup>L</sup>	2.6–3.6	0.30 <sup>L</sup>	0.20	0.15	0.05	0.15	remainder
6003 <sup>H</sup>	0.35–1.0	0.6	0.10	0.8	0.8–1.5	0.35	0.20	0.10	0.05	0.15	remainder
6013	0.6–1.0	0.50	0.6–1.1	0.20–0.8	0.8–1.2	0.10	0.25	0.10	0.05	0.15	remainder
6061	0.40–0.8	0.7	0.15–0.40	0.15	0.8–1.2	0.04–0.35	0.25	0.15	0.05	0.15	remainder
Alclad 6061					6061 clad with 7072						
7072 <sup>H</sup>	0.7 Si + Fe		0.10	0.10	0.10	...	0.8–1.3	...	0.05	0.15	remainder
7075	0.40	0.50	1.2–2.0	0.30	2.1–2.9	0.18–0.28	5.1–6.1	0.20	0.05	0.15	remainder
Alclad 7075					7075 clad with 7072						

<sup>A</sup> Limits are in weight percent maximum unless shown as a range or stated otherwise.

<sup>B</sup> Analysis shall be made for the elements for which limits are shown in this table.

<sup>C</sup> For purposes of determining conformance to these limits, an observed value or a calculated value attained from analysis shall be rounded to the nearest unit in the last righthand place of figures used in expressing the specified limit, in accordance with the Rounding Method of Practice E29.

<sup>D</sup> *Others* includes listed elements for which no specific limit is shown as well as unlisted metallic elements. The producer may analyze samples for trace elements not specified in the specification. However, such analysis is not required and may not cover all metallic *Others* elements. Should any analysis by the producer or the purchaser establish that an *Others* element exceeds the limit of *Each* or that the aggregate of several *Others* elements exceeds the limit of *Total*, the material shall be considered nonconforming. The Total for Other Elements does not include elements shown in the footnotes with specific composition limits.

<sup>E</sup> *Other Elements*—Total shall be the sum of unspecified metallic elements, 0.010 % or more, rounded to the second decimal before determining the sum.

<sup>F</sup> Vanadium 0.05 max.

<sup>G</sup> The aluminum content shall be calculated by subtracting from 100.00 % the sum of all metallic elements present in amounts of 0.010 % or more each, rounded to the second decimal before determining the sum.

<sup>H</sup> Composition of cladding alloy as applied during the course of manufacture. Samples from finished sheet or plate shall not be required to conform to these limits.

<sup>I</sup> Vanadium 0.05–0.15, zirconium 0.10–0.25.

<sup>J</sup> 0.05–0.25 Zr

<sup>K</sup> Gallium 0.03 max, vanadium 0.05 max.

<sup>L</sup> 0.10–0.6 Mn + Cr.

<sup>M</sup> In case there is a discrepancy in the values listed in Table 1 with those listed in the "International Alloy Designations and Chemical Composition Limits for Wrought Aluminum and Wrought Aluminum Alloys" (known as the "Teal Sheets"), the composition limits registered with the Aluminum Association and published in the "Teal Sheets" shall be considered the controlling composition. The "Teal Sheets" are available at <http://www.aluminum.org/tealsheets>.

## 5. Responsibility for Quality Assurance

5.1 *Responsibility for Inspection and Tests*—Unless otherwise specified in the contract or purchase order, the producer is responsible for the performance of all inspection and test requirements specified herein. The producer may use their own or any other suitable facilities for the performance of the inspection and test requirements specified herein, unless disapproved by the purchaser in the order or at the time of contract signing. The purchaser shall have the right to perform any of

the inspections and tests set forth in this specification where such inspections are deemed necessary to ensure that material conforms to prescribed requirements.

5.2 *Lot Definition*—An inspection lot shall be defined as follows:

5.2.1 For heat-treated tempers, an inspection lot shall consist of an identifiable quantity of material of the same mill form, alloy, temper, and thickness traceable to a heat-treat lot or lots, and subjected to inspection at one time.

TABLE 2 Mechanical Property Limits for Nonheat-treatable Alloy, Inch-Pound Units<sup>A,B,G</sup>

Alloy	Temper	Specified Thickness, in.	Tensile Strength, ksi		Yield Strength (0.2 % offset), ksi		Elongation in 2 in. or 4x Diameter, min, %	Bend Diameter Factor, N
			min	max	min	max		
1060	O	0.006–0.019	8.0	14.0	2.5	...	15	...
1060	O	0.020–0.050	8.0	14.0	2.5	...	22	...
1060	O	0.051–3.000	8.0	14.0	2.5	...	25	...
1060	H12 <sup>C</sup> or H22 <sup>C</sup>	0.017–0.050	11.0	16.0	9.0	...	6	...
1060	H12 <sup>C</sup> or H22 <sup>C</sup>	0.051–2.000	11.0	16.0	9.0	...	12	...
1060	H14 <sup>C</sup> or H24 <sup>C</sup>	0.009–0.019	12.0	17.0	10.0	...	1	...
1060	H14 <sup>C</sup> or H24 <sup>C</sup>	0.020–0.050	12.0	17.0	10.0	...	5	...
1060	H14 <sup>C</sup> or H24 <sup>C</sup>	0.051–1.000	12.0	17.0	10.0	...	10	...
1060	H16 <sup>C</sup> or H26 <sup>C</sup>	0.006–0.019	14.0	19.0	11.0	...	1	...
1060	H16 <sup>C</sup> or H26 <sup>C</sup>	0.020–0.050	14.0	19.0	11.0	...	4	...
1060	H16 <sup>C</sup> or H26 <sup>C</sup>	0.051–0.162	14.0	19.0	11.0	...	5	...
1060	H18 <sup>C</sup> or H28 <sup>C</sup>	0.006–0.019	16.0	...	12.0	...	1	...
1060	H18 <sup>C</sup> or H28 <sup>C</sup>	0.020–0.050	16.0	...	12.0	...	3	...
1060	H18 <sup>C</sup> or H28 <sup>C</sup>	0.051–0.128	16.0	...	12.0	...	4	...
1060	H112	0.250–0.499	11.0	...	7.0	...	10	...
1060	H112	0.500–1.000	10.0	...	5.0	...	20	...
1060	H112	1.001–3.000	9.0	...	4.0	...	25	...
1060	F	0.250–3.000	...	...	...	...	...	...
1100	O	0.006–0.019	11.0	15.5	3.5	...	15	0
1100	O	0.020–0.031	11.0	15.5	3.5	...	20	0
1100	O	0.032–0.050	11.0	15.5	3.5	...	25	0
1100	O	0.051–0.249	11.0	15.5	3.5	...	30	0
1100	O	0.250–3.000	11.0	15.5	3.5	...	28	0
1100	H12 <sup>C</sup> or H22 <sup>C</sup>	0.017–0.019	14.0	19.0	11.0	...	3	0
1100	H12 <sup>C</sup> or H22 <sup>C</sup>	0.020–0.031	14.0	19.0	11.0	...	4	0
1100	H12 <sup>C</sup> or H22 <sup>C</sup>	0.032–0.050	14.0	19.0	11.0	...	6	0
1100	H12 <sup>C</sup> or H22 <sup>C</sup>	0.051–0.113	14.0	19.0	11.0	...	8	0
1100	H12 <sup>C</sup> or H22 <sup>C</sup>	0.114–0.499	14.0	19.0	11.0	...	9	0
1100	H12 <sup>C</sup> or H22 <sup>C</sup>	0.500–2.000	14.0	19.0	11.0	...	12	0
1100	H14 <sup>C</sup> or H24 <sup>C</sup>	0.009–0.012	16.0	21.0	14.0	...	1	0
1100	H14 <sup>C</sup> or H24 <sup>C</sup>	0.013–0.019	16.0	21.0	14.0	...	2	0
1100	H14 <sup>C</sup> or H24 <sup>C</sup>	0.020–0.031	16.0	21.0	14.0	...	3	0
1100	H14 <sup>C</sup> or H24 <sup>C</sup>	0.032–0.050	16.0	21.0	14.0	...	4	0
1100	H14 <sup>C</sup> or H24 <sup>C</sup>	0.051–0.113	16.0	21.0	14.0	...	5	0
1100	H14 <sup>C</sup> or H24 <sup>C</sup>	0.114–0.499	16.0	21.0	14.0	...	6	0
1100	H14 <sup>C</sup> or H24 <sup>C</sup>	0.500–1.000	16.0	21.0	14.0	...	10	0
1100	H16 <sup>C</sup> or H26 <sup>C</sup>	0.006–0.019	19.0	24.0	17.0	...	1	4
1100	H16 <sup>C</sup> or H26 <sup>C</sup>	0.020–0.031	19.0	24.0	17.0	...	2	4
1100	H16 <sup>C</sup> or H26 <sup>C</sup>	0.032–0.050	19.0	24.0	17.0	...	3	4
1100	H16 <sup>C</sup> or H26 <sup>C</sup>	0.051–0.162	19.0	24.0	17.0	...	4	4
1100	H18 <sup>C</sup> or H28 <sup>C</sup>	0.006–0.019	22.0	...	...	...	1	...
1100	H18 <sup>C</sup> or H28 <sup>C</sup>	0.020–0.031	22.0	...	...	...	2	...
1100	H18 <sup>C</sup> or H28 <sup>C</sup>	0.032–0.050	22.0	...	...	...	3	...
1100	H18 <sup>C</sup> or H28 <sup>C</sup>	0.051–0.128	22.0	...	...	...	4	...
1100	H112	0.250–0.499	13.0	...	7.0	...	9	...
1100	H112	0.500–2.000	12.0	...	5.0	...	14	...
1100	H112	2.001–3.000	11.5	...	4.0	...	20	...
1100	F <sup>D</sup>	0.250–3.000	...	...	...	...	...	...
3003	O	0.006–0.007	14.0	19.0	5.0	...	14	0
3003	O	0.008–0.012	14.0	19.0	5.0	...	18	0
3003	O	0.013–0.031	14.0	19.0	5.0	...	20	0
3003	O	0.032–0.050	14.0	19.0	5.0	...	23	0
3003	O	0.051–0.249	14.0	19.0	5.0	...	25	0
3003	O	0.250–3.000	14.0	19.0	5.0	...	23	...
3003	H12 <sup>C</sup> or H22 <sup>C</sup>	0.017–0.019	17.0	23.0	12.0	...	3	0
3003	H12 <sup>C</sup> or H22 <sup>C</sup>	0.020–0.031	17.0	23.0	12.0	...	4	0
3003	H12 <sup>C</sup> or H22 <sup>C</sup>	0.032–0.050	17.0	23.0	12.0	...	5	0
3003	H12 <sup>C</sup> or H22 <sup>C</sup>	0.051–0.113	17.0	23.0	12.0	...	6	0
3003	H12 <sup>C</sup> or H22 <sup>C</sup>	0.114–0.161	17.0	23.0	12.0	...	7	0
3003	H12 <sup>C</sup> or H22 <sup>C</sup>	0.162–0.249	17.0	23.0	12.0	...	8	0
3003	H12 <sup>C</sup> or H22 <sup>C</sup>	0.250–0.499	17.0	23.0	12.0	...	9	...
3003	H12 <sup>C</sup> or H22 <sup>C</sup>	0.500–2.000	17.0	23.0	12.0	...	10	...
3003	H14 <sup>C</sup> or H24 <sup>C</sup>	0.009–0.012	20.0	26.0	17.0	...	1	0
3003	H14 <sup>C</sup> or H24 <sup>C</sup>	0.013–0.019	20.0	26.0	17.0	...	2	0
3003	H14 <sup>C</sup> or H24 <sup>C</sup>	0.020–0.031	20.0	26.0	17.0	...	3	0
3003	H14 <sup>C</sup> or H24 <sup>C</sup>	0.032–0.050	20.0	26.0	17.0	...	4	0
3003	H14 <sup>C</sup> or H24 <sup>C</sup>	0.051–0.113	20.0	26.0	17.0	...	5	0
3003	H14 <sup>C</sup> or H24 <sup>C</sup>	0.114–0.161	20.0	26.0	17.0	...	6	2

TABLE 2 Continued

Alloy	Temper	Specified Thickness, in.	Tensile Strength, ksi		Yield Strength (0.2 % offset), ksi		Elongation in 2 in. or 4x Diameter, min, %	Bend Diameter Factor, N
			min	max	min	max		
3003	H14 <sup>C</sup> or H24 <sup>C</sup>	0.162–0.249	20.0	26.0	17.0	...	7	2
3003	H14 <sup>C</sup> or H24 <sup>C</sup>	0.250–0.499	20.0	26.0	17.0	...	8	...
3003	H14 <sup>C</sup> or H24 <sup>C</sup>	0.500–1.000	20.0	26.0	17.0	...	10	...
3003	H16 <sup>C</sup> or H26 <sup>C</sup>	0.006–0.019	24.0	30.0	21.0	...	1	4
3003	H16 <sup>C</sup> or H26 <sup>C</sup>	0.020–0.031	24.0	30.0	21.0	...	2	4
3003	H16 <sup>C</sup> or H26 <sup>C</sup>	0.032–0.050	24.0	30.0	21.0	...	3	4
3003	H16 <sup>C</sup> or H26 <sup>C</sup>	0.051–0.162	24.0	30.0	21.0	...	4	6
3003	H18 <sup>C</sup> or H28 <sup>C</sup>	0.006–0.019	27.0	...	24.0	...	1	...
3003	H18 <sup>C</sup> or H28 <sup>C</sup>	0.020–0.031	27.0	...	24.0	...	2	...
3003	H18 <sup>C</sup> or H28 <sup>C</sup>	0.032–0.050	27.0	...	24.0	...	3	...
3003	H18 <sup>C</sup> or H28 <sup>C</sup>	0.051–0.128	27.0	...	24.0	...	4	...
3003	H112	0.250–0.499	17.0	...	10.0	...	8	...
3003	H112	0.500–2.000	15.0	...	6.0	...	12	...
3003	H112	2.001–3.000	14.5	...	6.0	...	18	...
3003	F <sup>D</sup>	0.250–3.000	...	...	...	...	...	...
Alclad 3003	O	0.006–0.007	13.0	18.0	4.5	...	14	...
Alclad 3003	O	0.008–0.012	13.0	18.0	4.5	...	18	...
Alclad 3003	O	0.013–0.031	13.0	18.0	4.5	...	20	...
Alclad 3003	O	0.032–0.050	13.0	18.0	4.5	...	23	...
Alclad 3003	O	0.051–0.249	13.0	18.0	4.5	...	25	...
Alclad 3003	O	0.250–0.499	13.0	18.0	4.5	...	23	...
Alclad 3003	O	0.500–3.000	14.0 <sup>E</sup>	19.0 <sup>E</sup>	5.0 <sup>E</sup>	...	23	...
Alclad 3003	H12 <sup>C</sup> or H22 <sup>C</sup>	0.017–0.031	16.0	22.0	11.0	...	4	...
Alclad 3003	H12 <sup>C</sup> or H22 <sup>C</sup>	0.032–0.050	16.0	22.0	11.0	...	5	...
Alclad 3003	H12 <sup>C</sup> or H22 <sup>C</sup>	0.051–0.113	16.0	22.0	11.0	...	6	...
Alclad 3003	H12 <sup>C</sup> or H22 <sup>C</sup>	0.114–0.161	16.0	22.0	11.0	...	7	...
Alclad 3003	H12 <sup>C</sup> or H22 <sup>C</sup>	0.162–0.249	16.0	22.0	11.0	...	8	...
Alclad 3003	H12 <sup>C</sup> or H22 <sup>C</sup>	0.250–0.499	16.0	22.0	11.0	...	9	...
Alclad 3003	H12 <sup>C</sup> or H22 <sup>C</sup>	0.500–2.000	17.0 <sup>E</sup>	23.0 <sup>E</sup>	12.0 <sup>E</sup>	...	10	...
Alclad 3003	H14 <sup>C</sup> or H24 <sup>C</sup>	0.009–0.012	19.0	25.0	16.0	...	1	...
Alclad 3003	H14 <sup>C</sup> or H24 <sup>C</sup>	0.013–0.019	19.0	25.0	16.0	...	2	...
Alclad 3003	H14 <sup>C</sup> or H24 <sup>C</sup>	0.020–0.031	19.0	25.0	16.0	...	3	...
Alclad 3003	H14 <sup>C</sup> or H24 <sup>C</sup>	0.032–0.050	19.0	25.0	16.0	...	4	...
Alclad 3003	H14 <sup>C</sup> or H24 <sup>C</sup>	0.051–0.113	19.0	25.0	16.0	...	5	...
Alclad 3003	H14 <sup>C</sup> or H24 <sup>C</sup>	0.114–0.161	19.0	25.0	16.0	...	6	...
Alclad 3003	H14 <sup>C</sup> or H24 <sup>C</sup>	0.162–0.249	19.0	25.0	16.0	...	7	...
Alclad 3003	H14 <sup>C</sup> or H24 <sup>C</sup>	0.250–0.499	19.0	25.0	16.0	...	8	...
Alclad 3003	H14 <sup>C</sup> or H24 <sup>C</sup>	0.500–1.000	20.0 <sup>E</sup>	26.0 <sup>E</sup>	17.0 <sup>E</sup>	...	10	...
Alclad 3003	H16 <sup>C</sup> or H26 <sup>C</sup>	0.006–0.019	23.0	29.0	20.0	...	1	...
Alclad 3003	H16 <sup>C</sup> or H26 <sup>C</sup>	0.020–0.031	23.0	29.0	20.0	...	2	...
Alclad 3003	H16 <sup>C</sup> or H26 <sup>C</sup>	0.032–0.050	23.0	29.0	20.0	...	3	...
Alclad 3003	H16 <sup>C</sup> or H26 <sup>C</sup>	0.051–0.162	23.0	29.0	20.0	...	4	...
Alclad 3003	H18	0.006–0.019	26.0	...	...	...	1	...
Alclad 3003	H18	0.020–0.031	26.0	...	...	...	2	...
Alclad 3003	H18	0.032–0.050	26.0	...	...	...	3	...
Alclad 3003	H18	0.051–0.128	26.0	...	...	...	4	...
Alclad 3003	H112	0.250–0.499	16.0	...	9.0	...	8	...
Alclad 3003	H112	0.500–2.000	15.0 <sup>E</sup>	...	6.0 <sup>E</sup>	...	12	...
Alclad 3003	H112	2.001–3.000	14.5 <sup>E</sup>	...	6.0 <sup>E</sup>	...	18	...
Alclad 3003	F <sup>D</sup>	0.250–3.000	...	...	...	...	...	...
3004	O	0.006–0.007	22.0	29.0	8.5	...	...	...
3004	O	0.008–0.019	22.0	29.0	8.5	...	10	0
3004	O	0.020–0.031	22.0	29.0	8.5	...	14	0
3004	O	0.032–0.050	22.0	29.0	8.5	...	16	0
3004	O	0.051–0.249	22.0	29.0	8.5	...	18	0
3004	O	0.250–3.000	22.0	29.0	8.5	...	16	...
3004	H32 <sup>C</sup> or H22 <sup>C</sup>	0.017–0.019	28.0	35.0	21.0	...	1	0
3004	H32 <sup>C</sup> or H22 <sup>C</sup>	0.020–0.031	28.0	35.0	21.0	...	3	1
3004	H32 <sup>C</sup> or H22 <sup>C</sup>	0.032–0.050	28.0	35.0	21.0	...	4	1
3004	H32 <sup>C</sup> or H22 <sup>C</sup>	0.051–0.113	28.0	35.0	21.0	...	5	2
3004	H32 <sup>C</sup> or H22 <sup>C</sup>	0.114–2.000	28.0	35.0	21.0	...	6	...
3004	H34 <sup>C</sup> or H24 <sup>C</sup>	0.009–0.019	32.0	38.0	25.0	...	1	2
3004	H34 <sup>C</sup> or H24 <sup>C</sup>	0.020–0.050	32.0	38.0	25.0	...	3	3
3004	H34 <sup>C</sup> or H24 <sup>C</sup>	0.051–0.113	32.0	38.0	25.0	...	4	4
3004	H34 <sup>C</sup> or H24 <sup>C</sup>	0.114–1.000	32.0	38.0	25.0	...	5	...
3004	H36 <sup>C</sup> or H26 <sup>C</sup>	0.006–0.007	35.0	41.0	28.0	...	...	...
3004	H36 <sup>C</sup> or H26 <sup>C</sup>	0.008–0.019	35.0	41.0	28.0	...	1	6
3004	H36 <sup>C</sup> or H26 <sup>C</sup>	0.020–0.031	35.0	41.0	28.0	...	2	6

TABLE 2 Continued

Alloy	Temper	Specified Thickness, in.	Tensile Strength, ksi		Yield Strength (0.2 % offset), ksi		Elongation in 2 in. or 4x Diameter, min, %	Bend Diameter Factor, N
			min	max	min	max		
3004	H36 <sup>C</sup> or H26 <sup>C</sup>	0.032–0.050	35.0	41.0	28.0	...	3	6
3004	H36 <sup>C</sup> or H26 <sup>C</sup>	0.051–0.162	35.0	41.0	28.0	...	4	8
3004	H38 <sup>C</sup> or H28 <sup>C</sup>	0.006–0.007	38.0	...	31.0	...	...	...
3004	H38 <sup>C</sup> or H28 <sup>C</sup>	0.008–0.019	38.0	...	31.0	...	1	...
3004	H38 <sup>C</sup> or H28 <sup>C</sup>	0.020–0.031	38.0	...	31.0	...	2	...
3004	H38 <sup>C</sup> or H28 <sup>C</sup>	0.032–0.050	38.0	...	31.0	...	3	...
3004	H38 <sup>C</sup> or H28 <sup>C</sup>	0.051–0.128	38.0	...	31.0	...	4	...
3004	H112	0.250–3.000	23.0	...	9.0	...	7	...
3004	F <sup>D</sup>	0.250–3.000	...	...	...	...	...	...
Alclad 3004	O	0.006–0.007	21.0	28.0	8.0	...	...	...
Alclad 3004	O	0.008–0.019	21.0	28.0	8.0	...	10	...
Alclad 3004	O	0.020–0.031	21.0	28.0	8.0	...	14	...
Alclad 3004	O	0.032–0.050	21.0	28.0	8.0	...	16	...
Alclad 3004	O	0.051–0.249	21.0	28.0	8.0	...	18	...
Alclad 3004	O	0.250–0.499	21.0	28.0	8.0	...	16	...
Alclad 3004	O	0.500–3.000	22.0 <sup>E</sup>	29.0 <sup>E</sup>	8.5 <sup>E</sup>	...	16	...
Alclad 3004	H32 <sup>C</sup> or H22 <sup>C</sup>	0.017–0.019	27.0	34.0	20.0	...	1	...
Alclad 3004	H32 <sup>C</sup> or H22 <sup>C</sup>	0.020–0.031	27.0	34.0	20.0	...	3	...
Alclad 3004	H32 <sup>C</sup> or H22 <sup>C</sup>	0.032–0.050	27.0	34.0	20.0	...	4	...
Alclad 3004	H32 <sup>C</sup> or H22 <sup>C</sup>	0.051–0.113	27.0	34.0	20.0	...	5	...
Alclad 3004	H32 <sup>C</sup> or H22 <sup>C</sup>	0.114–0.249	27.0	34.0	20.0	...	6	...
Alclad 3004	H32 <sup>C</sup> or H22 <sup>C</sup>	0.250–0.499	27.0	34.0	20.0	...	6	...
Alclad 3004	H32 <sup>C</sup> or H22 <sup>C</sup>	0.500–2.000	28.0 <sup>E</sup>	35.0 <sup>E</sup>	21.0 <sup>E</sup>	...	6	...
Alclad 3004	H34 <sup>C</sup> or H24 <sup>C</sup>	0.009–0.019	31.0	37.0	24.0	...	1	...
Alclad 3004	H34 <sup>C</sup> or H24 <sup>C</sup>	0.020–0.050	31.0	37.0	24.0	...	3	...
Alclad 3004	H34 <sup>C</sup> or H24 <sup>C</sup>	0.051–0.113	31.0	37.0	24.0	...	4	...
Alclad 3004	H34 <sup>C</sup> or H24 <sup>C</sup>	0.114–0.249	31.0	37.0	24.0	...	5	...
Alclad 3004	H34 <sup>C</sup> or H24 <sup>C</sup>	0.250–0.499	31.0	37.0	24.0	...	5	...
Alclad 3004	H34 <sup>C</sup> or H24 <sup>C</sup>	0.500–1.000	32.0 <sup>E</sup>	38.0 <sup>E</sup>	25.0 <sup>E</sup>	...	5	...
Alclad 3004	H36 <sup>C</sup> or H26 <sup>C</sup>	0.006–0.007	34.0	40.0	27.0	...	...	...
Alclad 3004	H36 <sup>C</sup> or H26 <sup>C</sup>	0.008–0.019	34.0	40.0	27.0	...	1	...
Alclad 3004	H36 <sup>C</sup> or H26 <sup>C</sup>	0.020–0.031	34.0	40.0	27.0	...	2	...
Alclad 3004	H36 <sup>C</sup> or H26 <sup>C</sup>	0.032–0.050	34.0	40.0	27.0	...	3	...
Alclad 3004	H36 <sup>C</sup> or H26 <sup>C</sup>	0.051–0.162	34.0	40.0	27.0	...	4	...
Alclad 3004	H38	0.006–0.007	37.0	...	...	...	...	...
Alclad 3004	H38	0.008–0.019	37.0	...	...	...	1	...
Alclad 3004	H38	0.020–0.031	37.0	...	...	...	2	...
Alclad 3004	H38	0.032–0.050	37.0	...	...	...	3	...
Alclad 3004	H38	0.051–0.128	37.0	...	...	...	4	...
Alclad 3004	H112	0.250–0.499	22.0	...	8.5	...	7	...
Alclad 3004	H112	0.500–3.000	23.0 <sup>E</sup>	...	9.0 <sup>E</sup>	...	7	...
Alclad 3004	F <sup>D</sup>	0.250–3.000	...	...	...	...	...	...
3005	O	0.006–0.007	17.0	24.0	6.5	...	10	...
3005	O	0.008–0.012	17.0	24.0	6.5	...	12	...
3005	O	0.013–0.019	17.0	24.0	6.5	...	14	...
3005	O	0.020–0.031	17.0	24.0	6.5	...	16	...
3005	O	0.032–0.050	17.0	24.0	6.5	...	18	...
3005	O	0.051–0.249	17.0	24.0	6.5	...	20	...
3005	H12	0.017–0.019	20.0	27.0	17.0	...	1	...
3005	H12	0.020–0.050	20.0	27.0	17.0	...	2	...
3005	H12	0.051–0.113	20.0	27.0	17.0	...	3	...
3005	H12	0.114–0.161	20.0	27.0	17.0	...	4	...
3005	H12	0.162–0.249	20.0	27.0	17.0	...	5	...
3005	H14	0.009–0.031	24.0	31.0	21.0	...	1	...
3005	H14	0.032–0.050	24.0	31.0	21.0	...	2	...
3005	H14	0.051–0.113	24.0	31.0	21.0	...	3	...
3005	H14	0.114–0.249	24.0	31.0	21.0	...	4	...
3005	H16	0.006–0.031	28.0	35.0	25.0	...	1	...
3005	H16	0.032–0.113	28.0	35.0	25.0	...	2	...
3005	H16	0.114–0.162	28.0	35.0	25.0	...	3	...
3005	H18	0.006–0.031	32.0	...	29.0	...	1	...
3005	H18	0.032–0.128	32.0	...	29.0	...	2	...
3005	H19	0.006–0.012	34.0	...	...	...	...	...
3005	H19	0.013–0.063	34.0	...	...	...	1	...
3005	H25	0.016–0.019	26.0	34.0	22.0	...	1	...
3005	H25	0.020–0.031	26.0	34.0	22.0	...	2	...
3005	H25	0.032–0.050	26.0	34.0	22.0	...	3	...
3005	H25	0.051–0.080	26.0	34.0	22.0	...	4	...

TABLE 2 Continued

Alloy	Temper	Specified Thickness, in.	Tensile Strength, ksi		Yield Strength (0.2 % offset), ksi		Elongation in 2 in. or 4x Diameter, min, %	Bend Diameter Factor, N
			min	max	min	max		
3005	H27	0.016-0.019	29.5	37.5	25.5	...	1	...
3005	H27	0.020-0.031	29.5	37.5	25.5	...	2	...
3005	H27	0.032-0.050	29.5	37.5	25.5	...	3	...
3005	H27	0.051-0.080	29.5	37.5	25.5	...	4	...
3005	H28	0.016-0.019	31.0	...	27.0	...	1	...
3005	H28	0.020-0.031	31.0	...	27.0	...	2	...
3005	H28	0.032-0.050	31.0	...	27.0	...	3	...
3005	H28	0.051-0.080	31.0	...	27.0	...	4	...
3105	O	0.013-0.019	14.0	21.0	5.0	...	16	...
3105	O	0.020-0.031	14.0	21.0	5.0	...	18	...
3105	O	0.032-0.080	14.0	21.0	5.0	...	20	...
3105	H12	0.017-0.019	19.0	26.0	15.0	...	1	...
3105	H12	0.020-0.031	19.0	26.0	15.0	...	1	...
3105	H12	0.032-0.050	19.0	26.0	15.0	...	2	...
3105	H12	0.051-0.080	19.0	26.0	15.0	...	3	...
3105	H14	0.013-0.019	22.0	29.0	18.0	...	1	...
3105	H14	0.020-0.031	22.0	29.0	18.0	...	1	...
3105	H14	0.032-0.050	22.0	29.0	18.0	...	2	...
3105	H14	0.051-0.080	22.0	29.0	18.0	...	2	...
3105	H16	0.013-0.031	25.0	32.0	21.0	...	1	...
3105	H16	0.032-0.050	25.0	32.0	21.0	...	2	...
3105	H16	0.051-0.080	25.0	32.0	21.0	...	2	...
3105	H18	0.013-0.031	28.0	...	24.0	...	1	...
3105	H18	0.032-0.050	28.0	...	24.0	...	1	...
3105	H18	0.051-0.080	28.0	...	24.0	...	2	...
3105	H22	0.013-0.019	19.0	...	15.0	...	3	...
3105	H22	0.020-0.031	19.0	...	15.0	...	4	...
3105	H22	0.032-0.050	19.0	...	15.0	...	5	...
3105	H22	0.051-0.080	19.0	...	15.0	...	6	...
3105	H24	0.013-0.019	22.0	...	18.0	...	2	...
3105	H24	0.020-0.031	22.0	...	18.0	...	3	...
3105	H24	0.032-0.050	22.0	...	18.0	...	4	...
3105	H24	0.051-0.080	22.0	...	18.0	...	6	...
3105	H25	0.013-0.019	23.0	...	19.0	...	2	...
3105	H25	0.020-0.031	23.0	...	19.0	...	3	...
3105	H25	0.032-0.050	23.0	...	19.0	...	4	...
3105	H25	0.051-0.080	23.0	...	19.0	...	6	...
3105	H26	0.013-0.031	25.0	...	21.0	...	3	...
3105	H26	0.032-0.050	25.0	...	21.0	...	4	...
3105	H26	0.051-0.080	25.0	...	21.0	...	5	...
3105	H28	0.013-0.031	28.0	...	24.0	...	2	...
3105	H28	0.032-0.050	28.0	...	24.0	...	3	...
3105	H28	0.051-0.080	28.0	...	24.0	...	4	...
5005	O	0.006-0.007	15.0	21.0	5.0	...	12	...
5005	O	0.008-0.012	15.0	21.0	5.0	...	14	...
5005	O	0.013-0.019	15.0	21.0	5.0	...	16	...
5005	O	0.020-0.031	15.0	21.0	5.0	...	18	...
5005	O	0.032-0.050	15.0	21.0	5.0	...	20	...
5005	O	0.051-0.113	15.0	21.0	5.0	...	21	...
5005	O	0.114-0.249	15.0	21.0	5.0	...	22	...
5005	O	0.250-3.000	15.0	21.0	5.0	...	22	...
5005	H12	0.017-0.019	18.0	24.0	14.0	...	2	...
5005	H12	0.020-0.031	18.0	24.0	14.0	...	3	...
5005	H12	0.032-0.050	18.0	24.0	14.0	...	4	...
5005	H12	0.051-0.113	18.0	24.0	14.0	...	6	...
5005	H12	0.114-0.161	18.0	24.0	14.0	...	7	...
5005	H12	0.162-0.249	18.0	24.0	14.0	...	8	...
5005	H12	0.250-0.499	18.0	24.0	14.0	...	9	...
5005	H12	0.500-2.000	18.0	24.0	14.0	...	10	...
5005	H14	0.009-0.031	21.0	27.0	17.0	...	1	...
5005	H14	0.032-0.050	21.0	27.0	17.0	...	2	...
5005	H14	0.051-0.113	21.0	27.0	17.0	...	3	...
5005	H14	0.114-0.161	21.0	27.0	17.0	...	5	...
5005	H14	0.162-0.249	21.0	27.0	17.0	...	6	...
5005	H14	0.250-0.499	21.0	27.0	17.0	...	8	...
5005	H14	0.500-1.000	21.0	27.0	17.0	...	10	...
5005	H16	0.006-0.031	24.0	30.0	20.0	...	1	...
5005	H16	0.032-0.050	24.0	30.0	20.0	...	2	...

TABLE 2 Continued

Alloy	Temper	Specified Thickness, in.	Tensile Strength, ksi		Yield Strength (0.2 % offset), ksi		Elongation in 2 in. or 4x Diameter, min, %	Bend Diameter Factor, N
			min	max	min	max		
5005	H16	0.051-0.162	24.0	30.0	20.0	...	3	...
5005	H18	0.006-0.031	27.0	...	...	...	1	...
5005	H18	0.032-0.050	27.0	...	...	...	2	...
5005	H18	0.051-0.128	27.0	...	...	...	3	...
5005	H32 <sup>C</sup> or H22 <sup>C</sup>	0.017-0.019	17.0	23.0	12.0	...	3	...
5005	H32 <sup>C</sup> or H22 <sup>C</sup>	0.020-0.031	17.0	23.0	12.0	...	4	...
5005	H32 <sup>C</sup> or H22 <sup>C</sup>	0.032-0.050	17.0	23.0	12.0	...	5	...
5005	H32 <sup>C</sup> or H22 <sup>C</sup>	0.051-0.113	17.0	23.0	12.0	...	7	...
5005	H32 <sup>C</sup> or H22 <sup>C</sup>	0.114-0.161	17.0	23.0	12.0	...	8	...
5005	H32 <sup>C</sup> or H22 <sup>C</sup>	0.162-0.249	17.0	23.0	12.0	...	9	...
5005	H32 <sup>C</sup> or H22 <sup>C</sup>	0.250-2.000	17.0	23.0	12.0	...	10	...
5005	H34 <sup>C</sup> or H24 <sup>C</sup>	0.009-0.012	20.0	26.0	15.0	...	2	...
5005	H34 <sup>C</sup> or H24 <sup>C</sup>	0.013-0.031	20.0	26.0	15.0	...	3	...
5005	H34 <sup>C</sup> or H24 <sup>C</sup>	0.032-0.050	20.0	26.0	15.0	...	4	...
5005	H34 <sup>C</sup> or H24 <sup>C</sup>	0.051-0.113	20.0	26.0	15.0	...	5	...
5005	H34 <sup>C</sup> or H24 <sup>C</sup>	0.114-0.161	20.0	26.0	15.0	...	6	...
5005	H34 <sup>C</sup> or H24 <sup>C</sup>	0.162-0.249	20.0	26.0	15.0	...	7	...
5005	H34 <sup>C</sup> or H24 <sup>C</sup>	0.250-0.499	20.0	26.0	15.0	...	8	...
5005	H34 <sup>C</sup> or H24 <sup>C</sup>	0.500-1.000	20.0	26.0	15.0	...	10	...
5005	H36 <sup>C</sup> or H26 <sup>C</sup>	0.006-0.007	23.0	29.0	18.0	...	1	...
5005	H36 <sup>C</sup> or H26 <sup>C</sup>	0.008-0.019	23.0	29.0	18.0	...	2	...
5005	H36 <sup>C</sup> or H26 <sup>C</sup>	0.020-0.031	23.0	29.0	18.0	...	3	...
5005	H36 <sup>C</sup> or H26 <sup>C</sup>	0.032-0.162	23.0	29.0	18.0	...	4	...
5005	H38	0.006-0.012	26.0	...	...	...	1	...
5005	H38	0.013-0.019	26.0	...	...	...	2	...
5005	H38	0.020-0.031	26.0	...	...	...	3	...
5005	H38	0.032-0.128	26.0	...	...	...	4	...
5005	H112	0.250-0.499	17.0	...	...	...	8	...
5005	H112	0.500-2.000	15.0	...	...	...	12	...
5005	H112	2.001-3.000	14.5	...	...	...	18	...
5005	F <sup>D</sup>	0.250-3.000	...	...	...	...	...	...
5010	O	0.010-0.070	15.0	21.0	5.0	...	3	...
5010	H22	0.010-0.070	17.0	23.0	14.0	...	2	...
5010	H24	0.010-0.070	20.0	26.0	17.0	...	1	...
5010	H26	0.010-0.070	23.0	29.0	21.0	...	1	...
5010	H28	0.010-0.070	26.0	...	...	...	...	...
5050	O	0.006-0.007	18.0	24.0	6.0	...	...	0
5050	O	0.008-0.019	18.0	24.0	6.0	...	16	0
5050	O	0.020-0.031	18.0	24.0	6.0	...	18	0
5050	O	0.032-0.113	18.0	24.0	6.0	...	20	0
5050	O	0.114-0.249	18.0	24.0	6.0	...	22	0
5050	O	0.250-3.000	18.0	24.0	6.0	...	20	2
5050	H32 <sup>C</sup> or H22 <sup>C</sup>	0.017-0.050	22.0	28.0	16.0	...	4	1
5050	H32 <sup>C</sup> or H22 <sup>C</sup>	0.051-0.249	22.0	28.0	16.0	...	6	2
5050	H34 <sup>C</sup> or H24 <sup>C</sup>	0.009-0.031	25.0	31.0	20.0	...	3	1
5050	H34 <sup>C</sup> or H24 <sup>C</sup>	0.032-0.050	25.0	31.0	20.0	...	4	1
5050	H34 <sup>C</sup> or H24 <sup>C</sup>	0.051-0.249	25.0	31.0	20.0	...	5	3
5050	H36 <sup>C</sup> or H26 <sup>C</sup>	0.006-0.019	27.0	33.0	22.0	...	2	3
5050	H36 <sup>C</sup> or H26 <sup>C</sup>	0.020-0.050	27.0	33.0	22.0	...	3	3
5050	H36 <sup>C</sup> or H26 <sup>C</sup>	0.051-0.162	27.0	33.0	22.0	...	4	4
5050	H38	0.006-0.007	29.0	...	...	...	...	...
5050	H38	0.008-0.031	29.0	...	...	...	2	...
5050	H38	0.032-0.050	29.0	...	...	...	3	...
5050	H38	0.051-0.128	29.0	...	...	...	4	...
5050	H112	0.250-3.000	20.0	...	8.0	...	12	...
5050	F <sup>D</sup>	0.250-3.000	...	...	...	...	...	...
5052	O	0.006-0.007	25.0	31.0	9.5	...	...	0
5052	O	0.008-0.012	25.0	31.0	9.5	...	14	0
5052	O	0.013-0.019	25.0	31.0	9.5	...	15	0
5052	O	0.020-0.031	25.0	31.0	9.5	...	16	0
5052	O	0.032-0.050	25.0	31.0	9.5	...	18	0
5052	O	0.051-0.113	25.0	31.0	9.5	...	19	0
5052	O	0.114-0.249	25.0	31.0	9.5	...	20	0
5052	O	0.250-3.000	25.0	31.0	9.5	...	18	...
5052	H141	0.090-0.174	35.5	...	24.0	...	6	...
5052	H141	0.175-0.300	34.0	...	24.0	...	8	...

TABLE 2 Continued

Alloy	Temper	Specified Thickness, in.	Tensile Strength, ksi		Yield Strength (0.2 % offset), ksi		Elongation in 2 in. or 4x Diameter, min, %	Bend Diameter Factor, N
			min	max	min	max		
5052	H32 <sup>C</sup> or H22 <sup>C</sup>	0.017–0.019	31.0	38.0	23.0	...	4	0
5052	H32 <sup>C</sup> or H22 <sup>C</sup>	0.020–0.050	31.0	38.0	23.0	...	5	1
5052	H32 <sup>C</sup> or H22 <sup>C</sup>	0.051–0.113	31.0	38.0	23.0	...	7	2
5052	H32 <sup>C</sup> or H22 <sup>C</sup>	0.114–0.249	31.0	38.0	23.0	...	9	3
5052	H32 <sup>C</sup> or H22 <sup>C</sup>	0.250–0.499	31.0	38.0	23.0	...	11	...
5052	H32 <sup>C</sup> or H22 <sup>C</sup>	0.500–2.000	31.0	38.0	23.0	...	12	...
5052	H34 <sup>C</sup> or H24 <sup>C</sup>	0.009–0.019	34.0	41.0	26.0	...	3	1
5052	H34 <sup>C</sup> or H24 <sup>C</sup>	0.020–0.050	34.0	41.0	26.0	...	4	2
5052	H34 <sup>C</sup> or H24 <sup>C</sup>	0.051–0.113	34.0	41.0	26.0	...	6	3
5052	H34 <sup>C</sup> or H24 <sup>C</sup>	0.114–0.249	34.0	41.0	26.0	...	7	4
5052	H34 <sup>C</sup> or H24 <sup>C</sup>	0.250–1.000	34.0	41.0	26.0	...	10	...
5052	H36 <sup>C</sup> or H26 <sup>C</sup>	0.006–0.007	37.0	44.0	29.0	...	2	4
5052	H36 <sup>C</sup> or H26 <sup>C</sup>	0.008–0.031	37.0	44.0	29.0	...	3	4
5052	H36 <sup>C</sup> or H26 <sup>C</sup>	0.032–0.162	37.0	44.0	29.0	...	4	5
5052	H38 <sup>C</sup> or H28 <sup>C</sup>	0.006–0.007	39.0	...	32.0	...	2	...
5052	H38 <sup>C</sup> or H28 <sup>C</sup>	0.008–0.031	39.0	...	32.0	...	3	...
5052	H38 <sup>C</sup> or H28 <sup>C</sup>	0.032–0.128	39.0	...	32.0	...	4	...
5052	H112	0.250–0.499	28.0	...	16.0	...	7	...
5052	H112	0.500–2.000	25.0	...	9.5	...	12	...
5052	H112	2.001–3.000	25.0	...	9.5	...	16	...
5052	H322	0.020–0.050	31.0	35.0	21.0	...	5	...
5052	H322	0.051–0.113	31.0	35.0	21.0	...	7	...
5052	H322	0.114–0.125	31.0	35.0	21.0	...	9	...
5052	F <sup>D</sup>	0.250–3.000	...	...	...	...	...	...
5059	O	0.078–0.249	48.0	...	23.0	...	24	...
5059	O	0.250–0.787	48.0	...	23.0	...	24	...
5059	O	0.788–1.575	48.0	...	23.0	...	20	...
5059	O	1.576–7.000	44.0	...	21.0	...	17	...
5059	H111	0.078–0.249	48.0	...	23.0	...	24	...
5059	H111	0.250–0.787	48.0	...	23.0	...	24	...
5059	H111	0.788–1.575	48.0	...	23.0	...	20	...
5059	H111	1.576–7.000	44.0	...	21.0	...	17	...
5083	O	0.051–1.500	40.0	51.0	18.0	29.0	16	...
5083	O	1.501–3.000	39.0	50.0	17.0	29.0	16	...
5083	O	3.001–4.000	38.0	...	16.0	...	16	...
5083	O	4.001–5.000	38.0	...	16.0	...	14	...
5083	O	5.001–7.000	37.0	...	15.0	...	14	...
5083	O	7.001–8.000	36.0	...	14.0	...	12	...
5083	H111	0.051–1.500	40.0	51.0	18.0	29.0	16	...
5083	H111	1.501–3.000	39.0	50.0	17.0	29.0	16	...
5083	H111	3.001–4.000	38.0	...	16.0	...	16	...
5083	H111	4.001–5.000	38.0	...	16.0	...	14	...
5083	H111	5.001–7.000	37.0	...	15.0	...	14	...
5083	H111	7.001–8.000	36.0	...	14.0	...	12	...
5083	H32	0.125–0.187	44.0	56.0	31.0	...	10	...
5083	H32	0.188–1.500	44.0	56.0	31.0	...	12	...
5083	H32	1.501–3.000	41.0	56.0	29.0	...	12	...
5083	H112	0.250–1.500	40.0	...	18.0	...	12	...
5083	H112	1.501–3.000	39.0	...	17.0	...	12	...
5083	F <sup>D</sup>	0.250–8.000	...	...	...	...	...	...
5086	O	0.020–0.050	35.0	44.0	14.0	...	15	...
5086	O	0.051–0.249	35.0	44.0	14.0	...	18	...
5086	O	0.250–2.000	35.0	44.0	14.0	...	16	...
5086	H32 <sup>C</sup> or H22 <sup>C</sup>	0.020–0.050	40.0	47.0	28.0	...	6	...
5086	H32 <sup>C</sup> or H22 <sup>C</sup>	0.051–0.249	40.0	47.0	28.0	...	8	...
5086	H32 <sup>C</sup> or H22 <sup>C</sup>	0.250–2.000	40.0	47.0	28.0	...	12	...
5086	H34 <sup>C</sup> or H24 <sup>C</sup>	0.009–0.019	44.0	51.0	34.0	...	4	...
5086	H34 <sup>C</sup> or H24 <sup>C</sup>	0.020–0.050	44.0	51.0	34.0	...	5	...
5086	H34 <sup>C</sup> or H24 <sup>C</sup>	0.051–0.249	44.0	51.0	34.0	...	6	...
5086	H34 <sup>C</sup> or H24 <sup>C</sup>	0.250–1.000	44.0	51.0	34.0	...	10	...
5086	H36 <sup>C</sup> or H26 <sup>C</sup>	0.006–0.019	47.0	54.0	38.0	...	3	...
5086	H36 <sup>C</sup> or H26 <sup>C</sup>	0.020–0.050	47.0	54.0	38.0	...	4	...
5086	H36 <sup>C</sup> or H26 <sup>C</sup>	0.051–0.162	47.0	54.0	38.0	...	6	...
5086	H38 <sup>C</sup> or H28 <sup>C</sup>	0.006–0.020	50.0	...	41.0	...	3	...
5086	H112	0.188–0.499	36.0	...	18.0	...	8	...
5086	H112	0.500–1.000	35.0	...	16.0	...	10	...

TABLE 2 Continued

Alloy	Temper	Specified Thickness, in.	Tensile Strength, ksi		Yield Strength (0.2 % offset), ksi		Elongation in 2 in. or 4x Diameter, min, %	Bend Diameter Factor, N
			min	max	min	max		
5086	H112	1.001-2.000	35.0	...	14.0	...	14	...
5086	H112	2.001-3.000	34.0	...	14.0	...	14	...
5086	F <sup>D</sup>	0.250-3.000	...	...	...	...	...	...
5154	O	0.020-0.031	30.0	41.0	11.0	...	12	...
5154	O	0.032-0.050	30.0	41.0	11.0	...	14	...
5154	O	0.051-0.113	30.0	41.0	11.0	...	16	...
5154	O	0.114-3.000	30.0	41.0	11.0	...	18	...
5154	H32 <sup>C</sup> or H22 <sup>C</sup>	0.020-0.050	36.0	43.0	26.0	...	5	...
5154	H32 <sup>C</sup> or H22 <sup>C</sup>	0.051-0.249	36.0	43.0	26.0	...	8	...
5154	H32 <sup>C</sup> or H22 <sup>C</sup>	0.250-2.000	36.0	43.0	26.0	...	12	...
5154	H34 <sup>C</sup> or H24 <sup>C</sup>	0.009-0.050	39.0	46.0	29.0	...	4	...
5154	H34 <sup>C</sup> or H24 <sup>C</sup>	0.051-0.161	39.0	46.0	29.0	...	6	...
5154	H34 <sup>C</sup> or H24 <sup>C</sup>	0.162-0.249	39.0	46.0	29.0	...	7	...
5154	H34 <sup>C</sup> or H24 <sup>C</sup>	0.250-1.000	39.0	46.0	29.0	...	10	...
5154	H36 <sup>C</sup> or H26 <sup>C</sup>	0.006-0.050	42.0	49.0	32.0	...	3	...
5154	H36 <sup>C</sup> or H26 <sup>C</sup>	0.051-0.113	42.0	49.0	32.0	...	4	...
5154	H36 <sup>C</sup> or H26 <sup>C</sup>	0.114-0.162	42.0	49.0	32.0	...	5	...
5154	H38 <sup>C</sup> or H28 <sup>C</sup>	0.006-0.050	45.0	...	35.0	...	3	...
5154	H38 <sup>C</sup> or H28 <sup>C</sup>	0.051-0.113	45.0	...	35.0	...	4	...
5154	H38 <sup>C</sup> or H28 <sup>C</sup>	0.114-0.128	45.0	...	35.0	...	5	...
5154	H112	0.250-0.499	32.0	...	18.0	...	8	...
5154	H112	0.500-2.000	30.0	...	11.0	...	11	...
5154	H112	2.001-3.000	30.0	...	11.0	...	15	...
5154	F <sup>D</sup>	0.250-3.000	...	...	...	...	...	...
5252	H24	0.030-0.090	30.0	38.0	...	...	10	...
5252	H25	0.030-0.090	31.0	39.0	...	...	9	...
5252	H28	0.030-0.090	38.0	...	...	...	3	...
5254	O	0.051-0.113	30.0	41.0	11.0	...	16	...
5254	O	0.114-3.000	30.0	41.0	11.0	...	18	...
5254	H32 <sup>C</sup> or H22 <sup>C</sup>	0.051-0.249	36.0	43.0	26.0	...	8	...
5254	H32 <sup>C</sup> or H22 <sup>C</sup>	0.250-2.000	36.0	43.0	26.0	...	12	...
5254	H34 <sup>C</sup> or H24 <sup>C</sup>	0.051-0.161	39.0	46.0	29.0	...	6	...
5254	H34 <sup>C</sup> or H24 <sup>C</sup>	0.162-0.249	39.0	46.0	29.0	...	7	...
5254	H34 <sup>C</sup> or H24 <sup>C</sup>	0.250-1.000	39.0	46.0	29.0	...	10	...
5254	H36 <sup>C</sup> or H26 <sup>C</sup>	0.051-0.113	42.0	49.0	32.0	...	4	...
5254	H36 <sup>C</sup> or H26 <sup>C</sup>	0.114-0.162	42.0	49.0	32.0	...	5	...
5254	H38 <sup>C</sup> or H28 <sup>C</sup>	0.051-0.113	45.0	...	35.0	...	4	...
5254	H38 <sup>C</sup> or H28 <sup>C</sup>	0.114-0.128	45.0	...	35.0	...	5	...
5254	H112	0.250-0.499	32.0	...	18.0	...	8	...
5254	H112	0.500-2.000	30.0	...	11.0	...	11	...
5254	H112	2.001-3.000	30.0	...	11.0	...	15	...
5254	F <sup>D</sup>	0.250-3.000	...	...	...	...	...	...
5454	O	0.020-0.031	31.0	41.0	12.0	...	12	...
5454	O	0.032-0.050	31.0	41.0	12.0	...	14	...
5454	O	0.051-0.113	31.0	41.0	12.0	...	16	...
5454	O	0.114-3.000	31.0	41.0	12.0	...	18	...
5454	H32 <sup>C</sup> or H22 <sup>C</sup>	0.020-0.050	36.0	44.0	26.0	...	5	...
5454	H32 <sup>C</sup> or H22 <sup>C</sup>	0.051-0.249	36.0	44.0	26.0	...	8	...
5454	H32 <sup>C</sup> or H22 <sup>C</sup>	0.250-2.000	36.0	44.0	26.0	...	12	...
5454	H34 <sup>C</sup> or H24 <sup>C</sup>	0.020-0.050	39.0	47.0	29.0	...	4	...
5454	H34 <sup>C</sup> or H24 <sup>C</sup>	0.051-0.161	39.0	47.0	29.0	...	6	...
5454	H34 <sup>C</sup> or H24 <sup>C</sup>	0.162-0.249	39.0	47.0	29.0	...	7	...
5454	H34 <sup>C</sup> or H24 <sup>C</sup>	0.250-1.000	39.0	47.0	29.0	...	10	...
5454	H112	0.250-0.499	32.0	...	18.0	...	8	...
5454	H112	0.500-2.000	31.0	...	12.0	...	11	...
5454	H112	2.001-3.000	31.0	...	12.0	...	15	...
5454	F <sup>D</sup>	0.250-3.000	...	...	...	...	...	...
5754	O	0.030-0.055	29.0	39.0	12.0	...	17	...
5754	O	0.056-0.087	29.0	39.0	12.0	...	18	...
5754	O	0.088-0.138	29.0	39.0	12.0	...	19	...

TABLE 2 Continued

Alloy	Temper	Specified Thickness, in.	Tensile Strength, ksi		Yield Strength (0.2 % offset), ksi		Elongation in 2 in. or 4x Diameter, min, %	Bend Diameter Factor, N
			min	max	min	max		
5456	O	0.051–1.500	42.0	53.0	19.0	30.0	16	...
5456	O	1.501–3.000	41.0	52.0	18.0	30.0	16	...
5456	O	3.001–5.000	40.0	...	17.0	...	14	...
5456	O	5.001–7.000	39.0	...	16.0	...	14	...
5456	O	7.001–8.000	38.0	...	15.0	...	12	...
5456	H32	0.188–0.499	46.0	59.0	33.0	...	12	...
5456	H32	0.500–1.500	44.0	56.0	31.0	...	12	...
5456	H32	1.501–3.000	41.0	54.0	29.0	...	12	...
5456	H112	0.250–1.500	42.0	...	19.0	...	12	...
5456	H112	1.501–3.000	41.0	...	18.0	...	12	...
5456	F <sup>D</sup>	0.250–8.000	...	...	...	...	...	...
5457	O	0.030–0.090	16.0	22.0	...	...	20	...
5657	H241 <sup>F</sup>	0.030–0.090	18.0	26.0	...	...	13	...
5657	H25	0.030–0.090	20.0	28.0	...	...	8	...
5657	H26	0.030–0.090	22.0	30.0	...	...	7	...
5657	H28	0.030–0.090	25.0	...	...	...	5	...

<sup>A</sup> To determine conformance to this specification each value for tensile strength and yield strength shall be rounded to the nearest 0.1 ksi and each value for elongation to the nearest 0.5 %, both in accordance with the Rounding Method of Practice E29.

<sup>B</sup> The basis for establishment of mechanical property limits is shown in Annex A1.

<sup>C</sup> Material in either of these tempers (H32 or H22), (H34 or H24), (H36 or H26), (H38 or H28), (H12 or H22), (H14 or H24), (H16 or H26), (H18 or H28), may be supplied at the option of the supplier, unless one is specifically excluded by the contract or purchase order. When ordered as H2x tempers, the maximum tensile strength and minimum yield strength do not apply. When H2x tempers are supplied instead of ordered H1x or H3x tempers, the supplied H2x temper material shall meet the respective H1x or H3x temper tensile property limits.

<sup>D</sup> Tests of F temper plate for tensile properties are not required.

<sup>E</sup> The tension test specimen from plate 0.500 in. and thicker is machined from the core and does not include the cladding alloy.

<sup>F</sup> This material is subject to some recrystallization and an attendant loss of brightness.

<sup>G</sup> Mechanical property requirements for product outside the gauge range covered by Table 2 shall be agreed upon between purchaser and producer.

5.2.2 For nonheat-treated tempers, an inspection lot shall consist of an identifiable quantity of material of the same mill form, alloy, temper, and thickness subjected to inspection at one time.

## 6. General Quality

6.1 Unless otherwise specified, the material shall be supplied in the mill finish, shall be uniform as defined by the requirements of this specification, and shall be commercially sound. Any requirement not covered is subject to negotiation between producer and purchaser.

6.2 Each sheet and plate shall be examined to determine conformance to this specification with respect to general quality and identification marking. On approval of the purchaser, however, the producer may use a system of statistical quality control for such examinations.

## 7. Chemical Composition

7.1 *Limits*—The sheet and plate shall conform to the chemical composition limits specified in Table 1. Conformance shall be determined by the producer by analyzing samples taken at the time the ingots are poured in accordance with Practices E716 and analyzed in accordance with Test Methods E34, E607, or E1251, or with EN 14242. At least one sample shall be taken for each group of ingots poured simultaneously from

the same source of molten metal. If the producer has determined the chemical composition during pouring of the ingots, they shall not be required to sample and analyze the finished product.

NOTE 4—It is standard practice in the United States aluminum industry to determine conformance to the chemical composition limits prior to further processing of ingots into wrought products. Due to the continuous nature of the process, it is not practical to keep a specific ingot analysis identified with a specific quantity of finished material.

7.2 If it becomes necessary to analyze sheet and plate for conformance to chemical composition limits, the methods of sampling and methods of analysis shall be as provided in the following:

7.2.1 *Methods of Sampling*—Samples for chemical analysis shall be taken in accordance with Practice B985.

7.2.2 *Methods of Analysis*—Analysis shall be performed in accordance with Test Methods E34, E607, or E1251, or with EN 14242.

NOTE 5—It is difficult to obtain a reliable analysis of each of the components of clad materials using material in its finished state. A reasonably accurate determination of the core composition can be made if the cladding is substantially removed prior to analysis. The cladding composition is more difficult to determine because of the relatively thin layer and because of diffusion of core elements to the cladding. The correctness of cladding alloy used can usually be verified by a combination of metallographic examination and spectrochemical analysis of the surface at several widely separated points.

TABLE 3 Mechanical Property Limits for Nonheat-treatable Alloys, SI Units<sup>A,B,H</sup>

Alloy	Temper	Specified Thickness, mm		Tensile Strength, MPa		Yield Strength (0.2 % offset), MPa		Elongation, min, % <sup>C</sup>		Bend Diameter Factor, N
		over	through	min	max	min	max	in 50 mm	in 5x Diameter	
1060	O	0.15	0.32	55	95	15	...	15	...	...
1060	O	0.32	0.63	55	95	15	...	18	...	...
1060	O	0.63	1.20	55	95	15	...	23	...	...
1060	O	1.20	6.30	55	95	15	...	25	...	...
1060	O	6.30	80.00	55	95	15	...	25	22	...
1060	H12 <sup>E</sup> or H22 <sup>E</sup>	0.40	0.63	75	110	60	...	6	...	...
1060	H12 <sup>E</sup> or H22 <sup>E</sup>	0.63	1.20	75	110	60	...	7	...	...
1060	H12 <sup>E</sup> or H22 <sup>E</sup>	1.20	6.30	75	110	60	...	12	...	...
1060	H12 <sup>E</sup> or H22 <sup>E</sup>	6.30	50.00	75	110	60	...	12	10	...
1060	H14 <sup>E</sup> or H24 <sup>E</sup>	0.20	0.32	85	120	70	...	1	...	...
1060	H14 <sup>E</sup> or H24 <sup>E</sup>	0.32	0.63	85	120	70	...	2	...	...
1060	H14 <sup>E</sup> or H24 <sup>E</sup>	0.63	1.20	85	120	70	...	6	...	...
1060	H14 <sup>E</sup> or H24 <sup>E</sup>	1.20	6.30	85	120	70	...	10	...	...
1060	H14 <sup>E</sup> or H24 <sup>E</sup>	6.30	25.00	85	120	70	...	10	9	...
1060	H16 <sup>E</sup> or H26 <sup>E</sup>	0.15	0.32	95	130	75	...	1	...	...
1060	H16 <sup>E</sup> or H26 <sup>E</sup>	0.32	0.63	95	130	75	...	2	...	...
1060	H16 <sup>E</sup> or H26 <sup>E</sup>	0.63	1.20	95	130	75	...	4	...	...
1060	H16 <sup>E</sup> or H26 <sup>E</sup>	1.20	4.00	95	130	75	...	5	...	...
1060	H18 <sup>E</sup> or H28 <sup>E</sup>	0.15	0.32	110	...	85	...	1	...	...
1060	H18 <sup>E</sup> or H28 <sup>E</sup>	0.32	0.63	110	...	85	...	2	...	...
1060	H18 <sup>E</sup> or H28 <sup>E</sup>	0.63	1.20	110	...	85	...	3	...	...
1060	H18 <sup>E</sup> or H28 <sup>E</sup>	1.20	3.20	110	...	85	...	4	...	...
1060	H112	6.30	12.50	75	...	...	...	10	...	...
1060	H112	12.50	40.00	70	...	...	...	...	18	...
1060	H112	40.00	80.00	60	...	...	...	...	22	...
1060	F <sup>D</sup>	6.30	80.00	...	...	...	...	...	...	...
1100	O	0.15	0.32	75	105	25	...	15	...	0
1100	O	0.32	0.63	75	105	25	...	17	...	0
1100	O	0.63	1.20	75	105	25	...	22	...	0
1100	O	1.20	6.30	75	105	25	...	30	...	0
1100	O	6.30	80.00	75	105	25	...	28	25	0
1100	H12 <sup>E</sup> or H22 <sup>E</sup>	0.40	0.63	95	130	75	...	3	...	0
1100	H12 <sup>E</sup> or H22 <sup>E</sup>	0.63	1.20	95	130	75	...	5	...	0
1100	H12 <sup>E</sup> or H22 <sup>E</sup>	1.20	6.30	95	130	75	...	8	...	0
1100	H12 <sup>E</sup> or H22 <sup>E</sup>	6.30	12.50	95	130	75	...	10	9	0
1100	H12 <sup>E</sup> or H22 <sup>E</sup>	12.50	50.00	95	130	75	...	10	9	...
1100	H14 <sup>E</sup> or H24 <sup>E</sup>	0.20	0.32	110	145	95	...	1	...	0
1100	H14 <sup>E</sup> or H24 <sup>E</sup>	0.32	0.63	110	145	95	...	2	...	0
1100	H14 <sup>E</sup> or H24 <sup>E</sup>	0.63	1.20	110	145	95	...	3	...	0
1100	H14 <sup>E</sup> or H24 <sup>E</sup>	1.20	6.30	110	145	95	...	5	...	0
1100	H14 <sup>E</sup> or H24 <sup>E</sup>	6.30	25.00	110	145	95	...	7	6	0
1100	H16 <sup>E</sup> or H26 <sup>E</sup>	0.15	0.32	130	165	115	...	1	...	4
1100	H16 <sup>E</sup> or H26 <sup>E</sup>	0.32	0.63	130	165	115	...	2	...	4
1100	H16 <sup>E</sup> or H26 <sup>E</sup>	0.63	1.20	130	165	115	...	3	...	4
1100	H16 <sup>E</sup> or H26 <sup>E</sup>	1.20	4.00	130	165	115	...	4	...	4
1100	H18 <sup>E</sup> or H28 <sup>E</sup>	0.15	0.32	150	...	...	...	1	...	...
1100	H18 <sup>E</sup> or H28 <sup>E</sup>	0.32	0.63	150	...	...	...	1	...	...
1100	H18 <sup>E</sup> or H28 <sup>E</sup>	0.63	1.20	150	...	...	...	2	...	...
1100	H18 <sup>E</sup> or H28 <sup>E</sup>	1.20	3.20	150	...	...	...	4	...	...
1100	H112	6.30	12.50	90	...	50	...	9	...	...
1100	H112	12.50	40.00	85	...	40	...	...	12	...
1100	H112	40.00	80.00	80	...	30	...	...	18	...
1100	F <sup>D</sup>	6.30	80.00	...	...	...	...	...	...	...
3003	O	0.15	0.20	95	130	35	...	14	...	0
3003	O	0.20	0.32	95	130	35	...	18	...	0
3003	O	0.32	0.63	95	130	35	...	20	...	0
3003	O	0.63	1.20	95	130	35	...	23	...	0
3003	O	1.20	6.30	95	130	35	...	25	...	0
3003	O	6.30	80.00	95	130	35	...	23	21	...
3003	H12 <sup>E</sup> or H22 <sup>E</sup>	0.40	0.63	120	160	85	...	3	...	0
3003	H12 <sup>E</sup> or H22 <sup>E</sup>	0.63	1.20	120	160	85	...	4	...	0
3003	H12 <sup>E</sup> or H22 <sup>E</sup>	1.20	6.30	120	160	85	...	6	...	0
3003	H12 <sup>E</sup> or H22 <sup>E</sup>	6.30	50.00	120	160	85	...	9	8	...
3003	H14 <sup>E</sup> or H24 <sup>E</sup>	0.20	0.32	140	180	115	...	1	...	0
3003	H14 <sup>E</sup> or H24 <sup>E</sup>	0.32	0.63	140	180	115	...	2	...	0
3003	H14 <sup>E</sup> or H24 <sup>E</sup>	0.63	1.20	140	180	115	...	3	...	0
3003	H14 <sup>E</sup> or H24 <sup>E</sup>	1.20	3.20	140	180	115	...	5	...	0
3003	H14 <sup>E</sup> or H24 <sup>E</sup>	3.20	6.30	140	180	115	...	5	...	2

TABLE 3 Continued

Alloy	Temper	Specified Thickness, mm		Tensile Strength, MPa		Yield Strength (0.2 % offset), MPa		Elongation, min, % <sup>C</sup>		Bend Diameter Factor, N
		over	through	min	max	min	max	in 50 mm	in 5x Diameter	
3003	H14 <sup>E</sup> or H24 <sup>E</sup>	6.30	25.00	140	180	115	...	8	7	...
3003	H16 <sup>E</sup> or H26 <sup>E</sup>	0.15	0.32	165	205	145	...	1	...	4
3003	H16 <sup>E</sup> or H26 <sup>E</sup>	0.32	0.63	165	205	145	...	2	...	4
3003	H16 <sup>E</sup> or H26 <sup>E</sup>	0.63	1.20	165	205	145	...	3	...	4
3003	H16 <sup>E</sup> or H26 <sup>E</sup>	1.20	4.00	165	205	145	...	4	...	6
3003	H18 <sup>E</sup> or H28 <sup>E</sup>	0.15	0.32	185	...	165	...	1	...	...
3003	H18 <sup>E</sup> or H28 <sup>E</sup>	0.32	0.63	185	...	165	...	1	...	...
3003	H18 <sup>E</sup> or H28 <sup>E</sup>	0.63	1.20	185	...	165	...	2	...	...
3003	H18 <sup>E</sup> or H28 <sup>E</sup>	1.20	3.20	185	...	165	...	4	...	...
3003	H112	6.30	12.50	115	...	70	...	8	...	...
3003	H112	12.50	40.00	105	...	40	...	...	10	...
3003	H112	40.00	80.00	100	...	40	...	...	16	...
3003	F <sup>F</sup>	6.30	80.00	...	...	...	...	...	...	...
Alclad 3003	O	0.15	0.32	90	125	30	...	14	...	...
Alclad 3003	O	0.32	0.63	90	125	30	...	20	...	...
Alclad 3003	O	0.63	1.20	90	125	30	...	22	...	...
Alclad 3003	O	1.20	6.30	90	125	30	...	25	...	...
Alclad 3003	O	6.30	12.50	90	125	30	...	23	...	...
Alclad 3003	O	12.50	80.00	95 <sup>F</sup>	130 <sup>F</sup>	35 <sup>F</sup>	...	...	21	...
Alclad 3003	H12 <sup>E</sup> or H22 <sup>E</sup>	0.40	0.63	115	155	80	...	4	...	...
Alclad 3003	H12 <sup>E</sup> or H22 <sup>E</sup>	0.63	1.20	115	155	80	...	5	...	...
Alclad 3003	H12 <sup>E</sup> or H22 <sup>E</sup>	1.20	6.30	115	155	80	...	6	...	...
Alclad 3003	H12 <sup>E</sup> or H22 <sup>E</sup>	6.30	12.50	115	155	80	...	9	...	...
Alclad 3003	H12 <sup>E</sup> or H22 <sup>E</sup>	12.50	50.00	120 <sup>F</sup>	160 <sup>F</sup>	85 <sup>F</sup>	...	...	8	...
Alclad 3003	H14 <sup>E</sup> or H24 <sup>E</sup>	0.20	0.32	135	175	110	...	1	...	...
Alclad 3003	H14 <sup>E</sup> or H24 <sup>E</sup>	0.32	0.63	135	175	110	...	2	...	...
Alclad 3003	H14 <sup>E</sup> or H24 <sup>E</sup>	0.63	1.20	135	175	110	...	3	...	...
Alclad 3003	H14 <sup>E</sup> or H24 <sup>E</sup>	1.20	6.30	135	175	110	...	5	...	...
Alclad 3003	H14 <sup>E</sup> or H24 <sup>E</sup>	6.30	12.50	135	175	110	...	8	...	...
Alclad 3003	H14 <sup>E</sup> or H24 <sup>E</sup>	12.50	25.00	140 <sup>F</sup>	180 <sup>F</sup>	115 <sup>F</sup>	...	...	7	...
Alclad 3003	H16 <sup>E</sup> or H26 <sup>E</sup>	0.15	0.32	160	200	140	...	1	...	...
Alclad 3003	H16 <sup>E</sup> or H26 <sup>E</sup>	0.32	0.63	160	200	140	...	2	...	...
Alclad 3003	H16 <sup>E</sup> or H26 <sup>E</sup>	0.63	1.20	160	200	140	...	3	...	...
Alclad 3003	H16 <sup>E</sup> or H26 <sup>E</sup>	1.20	4.00	160	200	140	...	4	...	...
Alclad 3003	H18	0.15	0.32	180	...	...	...	1	...	...
Alclad 3003	H18	0.32	0.63	180	...	...	...	1	...	...
Alclad 3003	H18	0.63	1.20	180	...	...	...	2	...	...
Alclad 3003	H18	1.20	3.20	180	...	...	...	4	...	...
Alclad 3003	H112	6.30	12.50	110	...	65	...	8	...	...
Alclad 3003	H112	12.50	40.00	105 <sup>F</sup>	...	40 <sup>F</sup>	...	...	10	...
Alclad 3003	H112	40.00	80.00	100 <sup>F</sup>	...	40 <sup>F</sup>	...	...	16	...
Alclad 3003	F <sup>D</sup>	6.30	80.00	...	...	...	...	...	...	...
3004	O	0.15	0.32	150	200	60	...	9	...	0
3004	O	0.32	0.63	150	200	60	...	12	...	0
3004	O	0.63	1.20	150	200	60	...	15	...	0
3004	O	1.20	6.30	150	200	60	...	18	...	0
3004	O	6.30	80.00	150	200	60	...	16	14	...
3004	H32 <sup>E</sup> or H22 <sup>E</sup>	0.40	0.63	190	240	145	...	1	...	0
3004	H32 <sup>E</sup> or H22 <sup>E</sup>	0.63	1.20	190	240	145	...	3	...	1
3004	H32 <sup>E</sup> or H22 <sup>E</sup>	1.20	3.20	190	240	145	...	5	...	2
3004	H32 <sup>E</sup> or H22 <sup>E</sup>	3.20	6.30	190	240	145	...	5	...	...
3004	H32 <sup>E</sup> or H22 <sup>E</sup>	6.30	50.00	190	240	145	...	6	5	...
3004	H34 <sup>E</sup> or H24 <sup>E</sup>	0.20	0.32	220	265	170	...	1	...	2
3004	H34 <sup>E</sup> or H24 <sup>E</sup>	0.32	0.63	220	265	170	...	2	...	2
3004	H34 <sup>E</sup> or H24 <sup>E</sup>	0.63	1.20	220	265	170	...	3	...	3
3004	H34 <sup>E</sup> or H24 <sup>E</sup>	1.20	3.20	220	265	170	...	4	...	4
3004	H34 <sup>E</sup> or H24 <sup>E</sup>	3.20	6.30	220	265	170	...	4	...	...
3004	H34 <sup>E</sup> or H24 <sup>E</sup>	6.30	25.00	220	265	170	...	5	4	...
3004	H36 <sup>E</sup> or H26 <sup>E</sup>	0.15	0.32	240	285	190	...	1	...	6
3004	H36 <sup>E</sup> or H26 <sup>E</sup>	0.32	0.63	240	285	190	...	2	...	6
3004	H36 <sup>E</sup> or H26 <sup>E</sup>	0.63	1.20	240	285	190	...	3	...	6
3004	H36 <sup>E</sup> or H26 <sup>E</sup>	1.20	4.00	240	285	190	...	4	...	8
3004	H38 <sup>E</sup> or H28 <sup>E</sup>	0.15	0.32	260	...	215	...	...	...	...
3004	H38 <sup>E</sup> or H28 <sup>E</sup>	0.32	0.63	260	...	215	...	1	...	...
3004	H38 <sup>E</sup> or H28 <sup>E</sup>	0.63	1.20	260	...	215	...	2	...	...
3004	H38 <sup>E</sup> or H28 <sup>E</sup>	1.20	3.20	260	...	215	...	4	...	...
3004	H112	6.30	12.50	160	...	60	...	7	...	...
3004	H112	12.50	40.00	160	...	60	...	...	6	...

TABLE 3 Continued

Alloy	Temper	Specified Thickness, mm		Tensile Strength, MPa		Yield Strength (0.2 % offset), MPa		Elongation, min, % <sup>C</sup>		Bend Diameter Factor, N
		over	through	min	max	min	max	in 50 mm	in 5x Diameter	
3004	H112	40.00	80.00	160	...	60	...	...	6	...
3004	F <sup>D</sup>	6.30	80.00	...	...	...	...	...	...	...
Alclad 3004	O	0.15	0.32	145	195	55	...	9	...	...
Alclad 3004	O	0.32	0.63	145	195	55	...	12	...	...
Alclad 3004	O	0.63	1.20	145	195	55	...	15	...	...
Alclad 3004	O	1.20	6.30	145	195	55	...	18	...	...
Alclad 3004	O	6.30	12.50	145	195	55	...	16	...	...
Alclad 3004	O	12.50	80.00	150 <sup>F</sup>	200 <sup>F</sup>	60 <sup>F</sup>	...	...	14	...
Alclad 3004	H32 <sup>E</sup> or H22 <sup>E</sup>	0.40	0.63	185	235	140	...	1	...	...
Alclad 3004	H32 <sup>E</sup> or H22 <sup>E</sup>	0.63	1.20	185	235	140	...	3	...	...
Alclad 3004	H32 <sup>E</sup> or H22 <sup>E</sup>	1.20	6.30	185	235	140	...	5	...	...
Alclad 3004	H32 <sup>E</sup> or H22 <sup>E</sup>	6.30	12.50	185	235	140	...	6	...	...
Alclad 3004	H32 <sup>E</sup> or H22 <sup>E</sup>	12.50	50.00	190 <sup>F</sup>	240 <sup>F</sup>	145 <sup>F</sup>	...	...	5	...
Alclad 3004	H34 <sup>E</sup> or H24 <sup>E</sup>	0.20	0.32	215	260	165	...	1	...	...
Alclad 3004	H34 <sup>E</sup> or H24 <sup>E</sup>	0.32	0.63	215	260	165	...	2	...	...
Alclad 3004	H34 <sup>E</sup> or H24 <sup>E</sup>	0.63	1.20	215	260	165	...	3	...	...
Alclad 3004	H34 <sup>E</sup> or H24 <sup>E</sup>	1.20	6.30	215	260	165	...	4	...	...
Alclad 3004	H34 <sup>E</sup> or H24 <sup>E</sup>	6.30	12.50	215	260	165	...	5	...	...
Alclad 3004	H34 <sup>E</sup> or H24 <sup>E</sup>	12.50	25.00	220 <sup>F</sup>	265 <sup>F</sup>	170 <sup>F</sup>	...	...	4	...
Alclad 3004	H36 <sup>E</sup> or H26 <sup>E</sup>	0.15	0.32	235	280	185	...	1	...	...
Alclad 3004	H36 <sup>E</sup> or H26 <sup>E</sup>	0.32	0.63	235	280	185	...	2	...	...
Alclad 3004	H36 <sup>E</sup> or H26 <sup>E</sup>	0.63	1.20	235	280	185	...	3	...	...
Alclad 3004	H36 <sup>E</sup> or H26 <sup>E</sup>	1.20	4.00	235	280	185	...	4	...	...
Alclad 3004	H38	0.15	0.32	255	...	...	...	...	...	...
Alclad 3004	H38	0.32	0.63	255	...	...	...	1	...	...
Alclad 3004	H38	0.63	1.20	255	...	...	...	2	...	...
Alclad 3004	H38	1.20	3.20	255	...	...	...	4	...	...
Alclad 3004	H112	6.30	12.50	155	...	55	...	7	...	...
Alclad 3004	H112	12.50	40.00	160 <sup>F</sup>	...	60 <sup>F</sup>	...	...	6	...
Alclad 3004	H112	40.00	80.00	160 <sup>F</sup>	...	60 <sup>F</sup>	...	...	6	...
Alclad 3004	F <sup>D</sup>	6.30	80.00	...	...	...	...	...	...	...
3005	O	0.15	0.32	115	165	45	...	10	...	...
3005	O	0.32	0.63	115	165	45	...	14	...	...
3005	O	0.63	1.20	115	165	45	...	17	...	...
3005	O	1.20	6.30	115	165	45	...	20	...	...
3005	H12	0.40	0.63	140	190	115	...	1	...	...
3005	H12	0.63	1.20	140	190	115	...	2	...	...
3005	H12	1.20	6.30	140	190	115	...	3	...	...
3005	H14	0.20	0.32	165	215	145	...	1	...	...
3005	H14	0.32	0.63	165	215	145	...	1	...	...
3005	H14	0.63	1.20	165	215	145	...	2	...	...
3005	H14	1.20	6.30	165	215	145	...	3	...	...
3005	H16	0.15	0.32	190	240	170	...	1	...	...
3005	H16	0.32	0.63	190	240	170	...	1	...	...
3005	H16	0.63	1.20	190	240	170	...	2	...	...
3005	H16	1.20	4.00	190	240	170	...	2	...	...
3005	H18	0.15	0.32	220	...	200	...	1	...	...
3005	H18	0.32	0.63	220	...	200	...	1	...	...
3005	H18	0.63	1.20	220	...	200	...	2	...	...
3005	H18	1.20	3.20	220	...	200	...	2	...	...
3005	H19	0.15	0.32	235	...	...	...	...	...	...
3005	H19	0.32	0.63	235	...	...	...	1	...	...
3005	H19	0.63	1.20	235	...	...	...	1	...	...
3005	H19	1.20	1.60	235	...	...	...	1	...	...
3005	H25	0.15	0.32	180	235	150	...	1	...	...
3005	H25	0.32	0.63	180	235	150	...	2	...	...
3005	H25	0.63	1.20	180	235	150	...	3	...	...
3005	H25	1.20	2.00	180	235	150	...	4	...	...
3005	H27	0.15	0.32	205	260	175	...	1	...	...
3005	H27	0.32	0.63	205	260	175	...	2	...	...
3005	H27	0.63	1.20	205	260	175	...	3	...	...
3005	H27	1.20	2.00	205	260	175	...	4	...	...
3005	H28	0.15	0.32	215	...	185	...	1	...	...
3005	H28	0.32	0.63	215	...	185	...	2	...	...
3005	H28	0.63	1.20	215	...	185	...	3	...	...
3005	H28	1.20	2.00	215	...	185	...	4	...	...

TABLE 3 Continued

Alloy	Temper	Specified Thickness, mm		Tensile Strength, MPa		Yield Strength (0.2 % offset), MPa		Elongation, min, % <sup>C</sup>		Bend Diameter Factor, N
		over	through	min	max	min	max	in 50 mm	in 5x Diameter	
3105	O	0.32	0.63	95	145	35	....	16	...	...
3105	O	0.63	1.20	95	145	35	...	19	...	...
3105	O	1.20	2.00	95	145	35	...	20	...	...
3105	H12	0.40	0.63	130	180	105	...	1	...	...
3105	H12	0.63	1.20	130	180	105	...	2	...	...
3105	H12	1.20	2.00	130	180	105	...	3	...	...
3105	H14	0.32	0.63	150	200	125	...	1	...	...
3105	H14	0.63	1.20	150	200	125	...	2	...	...
3105	H14	1.20	2.00	150	200	125	...	2	...	...
3105	H16	0.32	0.63	170	220	145	...	1	...	...
3105	H16	0.63	1.20	170	220	145	...	1	...	...
3105	H16	1.20	2.00	170	220	145	...	2	...	...
3105	H18	0.32	0.63	190	...	165	...	1	...	...
3105	H18	0.63	1.20	190	...	165	...	1	...	...
3105	H18	1.20	2.00	190	...	165	...	2	...	...
3105	H22	0.32	0.50	130	...	105	...	2	...	...
3105	H22	0.50	0.80	130	...	105	...	4	...	...
3105	H22	0.80	1.20	130	...	105	...	5	...	...
3105	H22	1.20	2.00	130	...	105	...	6	...	...
3105	H24	0.32	0.50	150	...	125	...	2	...	...
3105	H24	0.50	0.80	150	...	125	...	3	...	...
3105	H24	0.80	1.20	150	...	125	...	4	...	...
3105	H24	1.20	2.00	150	...	125	...	6	...	...
3105	H25	0.32	0.63	160	...	130	...	2	...	...
3105	H25	0.63	1.20	160	...	130	...	4	...	...
3105	H25	1.20	2.00	160	...	130	...	6	...	...
3105	H26	0.32	0.80	170	...	145	...	3	...	...
3105	H26	0.80	1.20	170	...	145	...	4	...	...
3105	H26	1.20	2.00	170	...	145	...	5	...	...
3105	H28	0.32	0.80	190	...	165	...	2	...	...
3105	H28	0.80	1.20	190	...	165	...	3	...	...
3105	H28	1.20	2.00	190	...	165	...	4	...	...
5005	O	0.15	0.32	105	145	35	...	12	...	...
5005	O	0.32	0.63	105	145	35	...	16	...	...
5005	O	0.63	1.20	105	145	35	...	19	...	...
5005	O	1.20	6.30	105	145	35	...	21	...	...
5005	O	6.30	80.00	105	145	35	...	22	20	...
5005	H12	0.40	0.63	125	165	95	...	2	...	...
5005	H12	0.63	1.20	125	165	95	...	4	...	...
5005	H12	1.20	6.30	125	165	95	...	6	...	...
5005	H12	6.30	50.00	125	165	95	...	9	8	...
5005	H14	0.20	0.32	145	185	115	...	1	...	...
5005	H14	0.32	0.63	145	185	115	...	1	...	...
5005	H14	0.63	1.20	145	185	115	...	2	...	...
5005	H14	1.20	6.30	145	185	115	...	3	...	...
5005	H14	6.30	25.00	145	185	115	...	8	7	...
5005	H16	0.15	0.32	165	205	135	...	1	...	...
5005	H16	0.32	0.63	165	205	135	...	1	...	...
5005	H16	0.63	1.20	165	205	135	...	2	...	...
5005	H16	1.20	4.00	165	205	135	...	3	...	...
5005	H18	0.15	0.32	185	...	...	...	1	...	...
5005	H18	0.32	0.63	185	...	...	...	1	...	...
5005	H18	0.63	1.20	185	...	...	...	2	...	...
5005	H18	1.20	3.20	185	...	...	...	3	...	...
5005	H32 <sup>E</sup> or H22 <sup>E</sup>	0.40	0.63	120	160	85	...	3	...	...
5005	H32 <sup>E</sup> or H22 <sup>E</sup>	0.63	1.20	120	160	85	...	4	...	...
5005	H32 <sup>E</sup> or H22 <sup>E</sup>	1.20	6.30	120	160	85	...	7	...	...
5005	H32 <sup>E</sup> or H22 <sup>E</sup>	6.30	50.00	120	160	85	...	10	9	...
5005	H34 <sup>E</sup> or H24 <sup>E</sup>	0.20	0.32	140	180	105	...	2	...	...
5005	H34 <sup>E</sup> or H24 <sup>E</sup>	0.32	0.63	140	180	105	...	3	...	...
5005	H34 <sup>E</sup> or H24 <sup>E</sup>	0.63	1.20	140	180	105	...	4	...	...
5005	H34 <sup>E</sup> or H24 <sup>E</sup>	1.20	6.30	140	180	105	...	5	...	...
5005	H34 <sup>E</sup> or H24 <sup>E</sup>	6.30	25.00	140	180	105	...	8	7	...
5005	H36 <sup>E</sup> or H26 <sup>E</sup>	0.15	0.32	160	200	125	...	1	...	...
5005	H36 <sup>E</sup> or H26 <sup>E</sup>	0.32	0.63	160	200	125	...	2	...	...
5005	H36 <sup>E</sup> or H26 <sup>E</sup>	0.63	1.20	160	200	125	...	3	...	...
5005	H36 <sup>E</sup> or H26 <sup>E</sup>	1.20	4.00	160	200	125	...	4	...	...
5005	H38	0.15	0.32	180	...	...	...	1	...	...
5005	H38	0.32	0.63	180	...	...	...	2	...	...
5005	H38	0.63	1.20	180	...	...	...	3	...	...

TABLE 3 Continued

Alloy	Temper	Specified Thickness, mm		Tensile Strength, MPa		Yield Strength (0.2 % offset), MPa		Elongation, min, % <sup>C</sup>		Bend Diameter Factor, N
		over	through	min	max	min	max	in 50 mm	in 5x Diameter	
5005	H38	1.20	3.20	180	...	...	...	4	...	...
5005	H112	6.30	12.50	115	...	...	...	8	...	...
5005	H112	12.50	40.00	105	...	...	...	10	...	...
5005	H112	40.00	80.00	100	...	...	...	16	...	...
5005	F <sup>D</sup>	6.30	80.00	...	...	...	...	...	...	...
5010	O	0.25	1.80	105	145	35	...	3	...	...
5010	H22	0.25	1.80	115	160	95	...	2	...	...
5010	H24	0.25	1.80	140	180	115	...	1	...	...
5010	H26	0.25	1.80	160	200	145	...	1	...	...
5010	H28	0.25	1.80	180	...	...	...	...	...	...
5050	O	0.15	0.32	125	165	40	...	15	...	0
5050	O	0.32	0.63	125	165	40	...	17	...	0
5050	O	0.63	1.20	125	165	40	...	19	...	0
5050	O	1.20	6.30	125	165	40	...	20	...	0
5050	O	6.30	80.00	125	165	40	...	20	18	2
5050	H32 <sup>E</sup> or H22 <sup>E</sup>	0.40	0.63	150	195	110	...	4	...	1
5050	H32 <sup>E</sup> or H22 <sup>E</sup>	0.63	1.20	150	195	110	...	5	...	1
5050	H32 <sup>E</sup> or H22 <sup>E</sup>	1.20	6.30	150	195	110	...	6	...	2
5050	H34 <sup>E</sup> or H24 <sup>E</sup>	0.20	0.32	170	215	140	...	3	...	1
5050	H34 <sup>E</sup> or H24 <sup>E</sup>	0.32	0.63	170	215	140	...	3	...	1
5050	H34 <sup>E</sup> or H24 <sup>E</sup>	0.63	1.20	170	215	140	...	4	...	1
5050	H34 <sup>E</sup> or H24 <sup>E</sup>	1.20	6.30	170	215	140	...	5	...	3
5050	H36 <sup>E</sup> or H26 <sup>E</sup>	0.15	0.32	185	230	150	...	2	...	3
5050	H36 <sup>E</sup> or H26 <sup>E</sup>	0.32	0.63	185	230	150	...	2	...	3
5050	H36 <sup>E</sup> or H26 <sup>E</sup>	0.63	1.20	185	230	150	...	3	...	3
5050	H36 <sup>E</sup> or H26 <sup>E</sup>	1.20	4.00	185	230	150	...	4	...	4
5050	H38	0.15	0.32	200	...	...	...	1	...	...
5050	H38	0.32	0.63	200	...	...	...	2	...	...
5050	H38	0.63	1.20	200	...	...	...	3	...	...
5050	H38	1.20	3.20	200	...	...	...	4	...	...
5050	H112	6.30	12.50	140	...	55	...	12	...	...
5050	H112	12.50	40.00	140	...	55	...	...	10	...
5050	H112	40.00	80.00	140	...	55	...	...	10	...
5050	F <sup>D</sup>	6.30	80.00	...	...	...	...	...	...	...
5052	O	0.15	0.32	170	215	65	...	13	...	0
5052	O	0.32	0.63	170	215	65	...	15	...	0
5052	O	0.63	1.20	170	215	65	...	17	...	0
5052	O	1.20	6.30	170	215	65	...	19	...	0
5052	O	6.30	80.00	170	215	65	...	18	16	...
5052	H141	2.00	5.00	245	...	165	...	6	...	...
5052	H141	5.00	8.00	235	...	165	...	8	...	...
5052	H32 <sup>E</sup> or H22 <sup>E</sup>	0.40	0.63	215	265	160	...	4	...	0
5052	H32 <sup>E</sup> or H22 <sup>E</sup>	0.63	1.20	215	265	160	...	5	...	1
5052	H32 <sup>E</sup> or H22 <sup>E</sup>	1.20	3.20	215	265	160	...	7	...	2
5052	H32 <sup>E</sup> or H22 <sup>E</sup>	3.20	6.30	215	265	160	...	7	...	3
5052	H32 <sup>E</sup> or H22 <sup>E</sup>	6.30	50.00	215	265	160	...	11	10	...
5052	H34 <sup>E</sup> or H24 <sup>E</sup>	0.20	0.32	235	285	180	...	3	...	1
5052	H34 <sup>E</sup> or H24 <sup>E</sup>	0.32	0.63	235	285	180	...	3	...	1
5052	H34 <sup>E</sup> or H24 <sup>E</sup>	0.63	1.20	235	285	180	...	4	...	2
5052	H34 <sup>E</sup> or H24 <sup>E</sup>	1.20	3.20	235	285	180	...	6	...	3
5052	H34 <sup>E</sup> or H24 <sup>E</sup>	3.20	6.30	235	285	180	...	6	...	4
5052	H34 <sup>E</sup> or H24 <sup>E</sup>	6.30	25.00	235	285	180	...	10	9	...
5052	H36 <sup>E</sup> or H26 <sup>E</sup>	0.15	0.32	255	305	200	...	2	...	4
5052	H36 <sup>E</sup> or H26 <sup>E</sup>	0.32	0.63	255	305	200	...	3	...	4
5052	H36 <sup>E</sup> or H26 <sup>E</sup>	0.63	1.20	255	305	200	...	4	...	5
5052	H36 <sup>E</sup> or H26 <sup>E</sup>	1.20	4.00	255	305	200	...	4	...	5
5052	H38 <sup>E</sup> or H28 <sup>E</sup>	0.15	0.32	270	...	220	...	2	...	...
5052	H38 <sup>E</sup> or H28 <sup>E</sup>	0.32	0.63	270	...	220	...	3	...	...
5052	H38 <sup>E</sup> or H28 <sup>E</sup>	0.63	1.20	270	...	220	...	4	...	...
5052	H38 <sup>E</sup> or H28 <sup>E</sup>	1.20	3.20	270	...	220	...	4	...	...
5052	H112	6.30	12.50	190	...	110	...	7	...	...
5052	H112	12.50	40.00	170	...	65	...	...	10	...
5052	H112	40.00	80.00	170	...	65	...	...	14	...
5052	H322	0.50	1.20	215	240	145	...	5	...	...
5052	H322	1.20	2.90	215	240	145	...	7	...	...
5052	H322	2.90	3.20	215	240	145	...	9	...	...
5052	F <sup>D</sup>	6.30	80.00	...	...	...	...	...	...	...

TABLE 3 Continued

Alloy	Temper	Specified Thickness, mm		Tensile Strength, MPa		Yield Strength (0.2 % offset), MPa		Elongation, min, % <sup>C</sup>		Bend Diameter Factor, <i>N</i>
		over	through	min	max	min	max	in 50 mm	in 5x Diameter	
5059	O	1.99	6.30	330	...	160	...	24	...	...
5059	O	6.30	12.50	330	...	160	...	24	...	...
5059	O	12.50	20.00	330	...	160	...	...	24	...
5059	O	20.00	40.00	330	...	160	...	...	20	...
5059	O	40.00	180.00	300	...	145	...	...	17	...
5059	H111	1.99	6.30	330	...	160	...	24	...	...
5059	H111	6.30	12.50	330	...	160	...	24	...	...
5059	H111	12.50	20.00	330	...	160	...	...	24	...
5059	H111	20.00	40.00	330	...	160	...	...	20	...
5059	H111	40.00	180.00	300	...	145	...	...	17	...
5059	F <sup>D</sup>	6.30	200.00	...	...	...	...	...	...	...
5083	O	1.20	40.00	275	350	125	200	16	14	...
5083	O	40.00	80.00	270	345	115	200	...	14	...
5083	O	80.00	100.00	260	...	110	...	...	14	...
5083	O	100.00	120.00	260	...	110	...	...	12	...
5083	O	120.00	180.00	255	...	105	...	...	12	...
5083	O	180.00	200.00	250	...	95	...	...	10	...
5083	H111	1.20	40.00	275	350	125	200	16	14	...
5083	H111	40.00	80.00	270	345	115	200	...	14	...
5083	H111	80.00	100.00	260	...	110	...	...	14	...
5083	H111	100.00	120.00	260	...	110	...	...	12	...
5083	H111	120.00	180.00	255	...	105	...	...	12	...
5083	H111	180.00	200.00	250	...	95	...	...	10	...
5083	H112	6.30	12.50	275	...	125	...	12	...	...
5083	H112	12.50	40.00	275	...	125	...	...	10	...
5083	H112	40.00	80.00	270	...	115	...	...	10	...
5083	H32	3.20	5.00	305	385	215	...	10	...	...
5083	H32	5.00	12.50	305	385	215	...	12	...	...
5083	H32	12.50	40.00	305	385	215	...	...	10	...
5083	H32	40.00	80.00	285	385	200	...	...	10	...
5083	F <sup>D</sup>	6.30	200.00	...	...	...	...	...	...	...
5086	O	0.50	0.63	240	305	95	...	15	...	...
5086	O	0.63	1.20	240	305	95	...	16	...	...
5086	O	1.20	6.30	240	305	95	...	18	...	...
5086	O	6.30	50.00	240	305	95	...	16	14	...
5086	H32 <sup>E</sup> or H22 <sup>E</sup>	0.50	0.63	275	325	195	...	6	...	...
5086	H32 <sup>E</sup> or H22 <sup>E</sup>	0.63	1.20	275	325	195	...	6	...	...
5086	H32 <sup>E</sup> or H22 <sup>E</sup>	1.20	6.30	275	325	195	...	8	...	...
5086	H32 <sup>E</sup> or H22 <sup>E</sup>	6.30	50.00	275	325	195	...	12	10	...
5086	H34 <sup>E</sup> or H24 <sup>E</sup>	0.20	0.32	300	350	235	...	4	...	...
5086	H34 <sup>E</sup> or H24 <sup>E</sup>	0.32	0.63	300	350	235	...	4	...	...
5086	H34 <sup>E</sup> or H24 <sup>E</sup>	0.63	1.20	300	350	235	...	5	...	...
5086	H34 <sup>E</sup> or H24 <sup>E</sup>	1.20	6.30	300	350	235	...	6	...	...
5086	H34 <sup>E</sup> or H24 <sup>E</sup>	6.30	25.00	300	350	235	...	10	9	...
5086	H36 <sup>E</sup> or H26 <sup>E</sup>	0.15	0.32	325	375	260	...	3	...	...
5086	H36 <sup>E</sup> or H26 <sup>E</sup>	0.32	0.63	325	375	260	...	3	...	...
5086	H36 <sup>E</sup> or H26 <sup>E</sup>	0.63	1.20	325	375	260	...	4	...	...
5086	H36 <sup>E</sup> or H26 <sup>E</sup>	1.20	4.00	325	375	260	...	6	...	...
5086	H38 <sup>E</sup> or H28 <sup>E</sup>	0.15	0.63	345	...	285	...	3	...	...
5086	H112	4.00	12.50	250	...	125	...	8	...	...
5086	H112	12.50	40.00	240	...	105	...	...	9	...
5086	H112	40.00	80.00	235	...	95	...	...	12	...
5086	F <sup>D</sup>	6.30	80.00	...	...	...	...	...	...	...
5154	O	0.50	0.63	205	285	75	...	12	...	...
5154	O	0.63	1.20	205	285	75	...	13	...	...
5154	O	1.20	6.30	205	285	75	...	16	...	...
5154	O	6.30	80.00	205	285	75	...	18	16	...
5154	H32 <sup>E</sup> or H22 <sup>E</sup>	0.50	0.63	250	300	180	...	5	...	...
5154	H32 <sup>E</sup> or H22 <sup>E</sup>	0.63	1.20	250	300	180	...	6	...	...
5154	H32 <sup>E</sup> or H22 <sup>E</sup>	1.20	6.30	250	300	180	...	8	...	...
5154	H32 <sup>E</sup> or H22 <sup>E</sup>	6.30	50.00	250	300	180	...	12	10	...
5154	H34 <sup>E</sup> or H24 <sup>E</sup>	0.20	0.32	270	320	200	...	4	...	...
5154	H34 <sup>E</sup> or H24 <sup>E</sup>	0.32	0.63	270	320	200	...	4	...	...
5154	H34 <sup>E</sup> or H24 <sup>E</sup>	0.63	1.20	270	320	200	...	5	...	...

TABLE 3 Continued

Alloy	Temper	Specified Thickness, mm		Tensile Strength, MPa		Yield Strength (0.2 % offset), MPa		Elongation, min, % <sup>C</sup>		Bend Diameter Factor, N
		over	through	min	max	min	max	in 50 mm	in 5x Diameter	
5154	H34 <sup>E</sup> or H24 <sup>E</sup>	1.20	6.30	270	320	200	...	6	...	...
5154	H34 <sup>E</sup> or H24 <sup>E</sup>	6.30	25.00	270	320	200	...	10	9	...
5154	H36 <sup>E</sup> or H26 <sup>E</sup>	0.15	0.32	290	340	220	...	3	...	...
5154	H36 <sup>E</sup> or H26 <sup>E</sup>	0.32	0.63	290	340	220	...	3	...	...
5154	H36 <sup>E</sup> or H26 <sup>E</sup>	0.63	1.20	290	340	220	...	4	...	...
5154	H36 <sup>E</sup> or H26 <sup>E</sup>	1.20	4.00	290	340	220	...	4	...	...
5154	H38 <sup>E</sup> or H28 <sup>E</sup>	0.15	0.32	310	...	240	...	3	...	...
5154	H38 <sup>E</sup> or H28 <sup>E</sup>	0.32	0.63	310	...	240	...	3	...	...
5154	H38 <sup>E</sup> or H28 <sup>E</sup>	0.63	1.20	310	...	240	...	3	...	...
5154	H38 <sup>E</sup> or H28 <sup>E</sup>	1.20	3.20	310	...	240	...	4	...	...
5154	H112	6.30	12.50	220	...	125	...	8	...	...
5154	H112	12.50	40.00	210	...	90	...	...	9	...
5154	H112	40.00	80.00	205	...	75	...	...	13	...
5154	F <sup>D</sup>	6.30	80.00	...	...	...	...	...	...	...
5252	H24	0.63	2.50	205	260	...	...	10	...	...
5252	H25	0.63	2.50	215	270	...	...	9	...	...
5252	H28	0.63	2.50	260	...	...	...	3	...	...
5254	O	0.50	0.63	205	285	75	...	12	...	...
5254	O	0.63	1.20	205	285	75	...	13	...	...
5254	O	1.20	6.30	205	285	75	...	16	...	...
5254	O	6.30	80.00	205	285	75	...	18	16	...
5254	H32 <sup>E</sup> or H22 <sup>E</sup>	0.50	0.63	250	300	180	...	5	...	...
5254	H32 <sup>E</sup> or H22 <sup>E</sup>	0.63	1.20	250	300	180	...	6	...	...
5254	H32 <sup>E</sup> or H22 <sup>E</sup>	1.20	6.30	250	300	180	...	8	...	...
5254	H32 <sup>E</sup> or H22 <sup>E</sup>	6.30	50.00	250	300	180	...	12	10	...
5254	H34 <sup>E</sup> or H24 <sup>E</sup>	0.20	0.32	270	320	200	...	4	...	...
5254	H34 <sup>E</sup> or H24 <sup>E</sup>	0.32	0.63	270	320	200	...	4	...	...
5254	H34 <sup>E</sup> or H24 <sup>E</sup>	0.63	1.20	270	320	200	...	5	...	...
5254	H34 <sup>E</sup> or H24 <sup>E</sup>	1.20	6.30	270	320	200	...	6	...	...
5254	H34 <sup>E</sup> or H24 <sup>E</sup>	6.30	25.00	270	320	200	...	10	9	...
5254	H36 <sup>E</sup> or H26 <sup>E</sup>	0.15	0.32	290	340	220	...	3	...	...
5254	H36 <sup>E</sup> or H26 <sup>E</sup>	0.32	0.63	290	340	220	...	3	...	...
5254	H36 <sup>E</sup> or H26 <sup>E</sup>	0.63	1.20	290	340	220	...	4	...	...
5254	H36 <sup>E</sup> or H26 <sup>E</sup>	1.20	4.00	290	340	220	...	4	...	...
5254	H38 <sup>E</sup> or H28 <sup>E</sup>	0.15	0.32	310	...	240	...	3	...	...
5254	H38 <sup>E</sup> or H28 <sup>E</sup>	0.32	0.63	310	...	240	...	3	...	...
5254	H38 <sup>E</sup> or H28 <sup>E</sup>	0.63	1.20	310	...	240	...	3	...	...
5254	H38 <sup>E</sup> or H28 <sup>E</sup>	1.20	3.20	310	...	240	...	4	...	...
5254	H112	6.30	12.50	220	...	125	...	8	...	...
5254	H112	12.50	40.00	210	...	90	...	...	9	...
5254	H112	40.00	80.00	205	...	75	...	...	13	...
5254	F <sup>D</sup>	6.30	80.00	...	...	...	...	...	...	...
5454	O	0.50	0.63	215	285	85	...	12	...	...
5454	O	0.63	1.20	215	285	85	...	13	...	...
5454	O	1.20	6.30	215	285	85	...	16	...	...
5454	O	6.30	80.00	215	285	85	...	18	16	...
5454	H32 <sup>E</sup> or H22 <sup>E</sup>	0.50	0.63	250	305	180	...	5	...	...
5454	H32 <sup>E</sup> or H22 <sup>E</sup>	0.63	1.20	250	305	180	...	6	...	...
5454	H32 <sup>E</sup> or H22 <sup>E</sup>	1.20	6.30	250	305	180	...	8	...	...
5454	H32 <sup>E</sup> or H22 <sup>E</sup>	6.30	50.00	250	305	180	...	12	10	...
5454	H34 <sup>E</sup> or H24 <sup>E</sup>	0.50	0.63	270	325	200	...	4	...	...
5454	H34 <sup>E</sup> or H24 <sup>E</sup>	0.63	1.20	270	325	200	...	5	...	...
5454	H34 <sup>E</sup> or H24 <sup>E</sup>	1.20	6.30	270	325	200	...	6	...	...
5454	H34 <sup>E</sup> or H24 <sup>E</sup>	6.30	25.00	270	325	200	...	10	9	...
5454	H112	6.30	12.50	220	...	125	...	8	...	...
5454	H112	12.50	40.00	215	...	85	...	...	9	...
5454	H112	40.00	80.00	215	...	85	...	...	13	...
5454	F <sup>D</sup>	6.30	80.00	...	...	...	...	...	...	...
5754	O	0.75	1.40	200	270	80	...	17	...	...
5754	O	1.40	2.20	200	270	80	...	18	...	...
5754	O	2.20	3.50	200	270	80	...	19	...	...
5456	O	1.20	6.30	290	365	130	205	16	...	...

TABLE 3 Continued

Alloy	Temper	Specified Thickness, mm		Tensile Strength, MPa		Yield Strength (0.2 % offset), MPa		Elongation, min, % <sup>C</sup>		Bend Diameter Factor, <i>N</i>
		over	through	min	max	min	max	in 50 mm	in 5× Diameter	
5456	O	6.30	80.00	285	360	125	205	16	14	...
5456	O	80.00	120.00	275	...	120	...	...	12	...
5456	O	120.00	160.00	270	...	115	...	...	12	...
5456	O	160.00	200.00	265	...	105	...	...	10	...
5456	H112	6.30	12.50	290	...	130	...	12	...	...
5456	H112	12.50	40.00	290	...	130	...	...	10	...
5456	H112	40.00	80.00	285	...	125	...	...	10	...
5456	H32	4.00	12.50	315	405	230	...	12	...	...
5456	H32	12.50	40.00	305	385	215	...	...	10	...
5456	H32	40.00	80.00	285	370	200	...	...	10	...
5456	F <sup>D</sup>	6.30	200.00	...	...	...	...	...	...	...
5457	O	0.63	2.50	110	150	...	...	20	...	...
5657	H241 <sup>G</sup>	0.63	2.50	125	180	...	...	13	...	...
5657	H25	0.63	2.50	140	195	...	...	8	...	...
5657	H26	0.63	2.50	150	205	...	...	7	...	...
5657	H28	0.63	2.50	170	...	...	...	5	...	...

<sup>A</sup> To determine conformance to this specification, each value for tensile strength and for yield strength shall be rounded to the nearest 1 MPa and each value for elongation to the nearest 0.5 %, both in accordance with the Rounding Method of Practice E29.

<sup>B</sup> The basis for establishment of mechanical property limits is shown in Annex A1.

<sup>C</sup> Elongations in 50 mm apply for thicknesses up through 12.50 mm and in 5× diameter for thicknesses over 12.50 mm.

<sup>D</sup> Materials in either of these tempers, (H32 or H22), (H34 or H24), (H36 or H26), (H38 or H28), (H12 or H22), (H14 or H24), (H16 or H26), (H18 or H28), may be supplied at the option of the supplier, unless one is specifically excluded by the contract or purchase order. When ordered as H2X tempers, the maximum tensile strength and minimum yield strength do not apply. When H2X tempers are supplied instead of ordered H1X or H3X tempers, the supplied H2X temper material shall meet the respective H1X or H3X temper tensile property limits.

<sup>E</sup> Tests of F temper plate for tensile properties are not required.

<sup>F</sup> The tension test specimen from plate over 12.50 mm in thickness is machined from the core and does not include the cladding alloy.

<sup>G</sup> This material is subject to some recrystallization and an attendant loss of brightness.

<sup>H</sup> Mechanical property requirements for product outside the gauge range covered by Table 3 shall be agreed upon between purchaser and producer.

## 8. Heat Treatment

8.1 Unless specified in 8.2 or as noted in 8.3, producer or supplier heat treatment for the applicable tempers in Table 4 or Table 5 shall be in accordance with AMS 2772.

8.2 When specified (4.2.2), heat treatment of applicable tempers in Table 4 and Table 5 shall be in accordance with Practice B918/B918M.

8.3 When specified (4.2.3), alloy 6061 plate may be produced using hot rolling mill solution heat treatment in accordance with Practice B947, when aged in accordance with Practice B918/B918M for the production of T651 tempers, as applicable.

## 9. Tensile Properties of Material as Supplied

9.1 *Limits*—The sheet and plate shall conform to the requirements for tensile properties as specified in Table 2, Table 3, Table 4, and Table 5 for nonheat-treatable and heat-treatable alloys, respectively.

9.1.1 Tensile property limits for sizes not covered in Table 2, Table 3, Table 4, or Table 5 shall be as agreed upon between the producer and purchaser and shall be so specified in the contract or purchase order.

9.2 *Number of Samples*—One sample shall be taken from each end of each parent coil, or parent plate, but no more than one sample per 2000 lb of sheet or 4000 lb of plate, or part thereof, in a lot shall be required. Other procedures for

selecting samples may be employed if agreed upon between the producer and purchaser.

9.3 *Test Specimens*—Geometry of test specimens and the location in the product from which they are taken shall be as specified in Test Method B557 or B557M.

9.4 *Test Direction*—Unless otherwise specified, tensile testing shall be in the direction specified in Test Method B557 or B557M. When a direction other than specified in Test Method B557 or B557M is tested, the tensile testing direction shall be noted on all documentation.

9.5 *Test Methods*—The tension test shall be made in accordance with Test Method B557 or B557M.

## 10. Producer Confirmation of Heat-treat Response

10.1 In addition to the requirements of 9.1, material in the O or F temper of alloys 2014, Alclad 2014, 2024, Alclad 2024, 1½ % Alclad 2024, Alclad one-side 2024, 1½ % Alclad one-side 2024, 6061, and Alclad 6061 shall, upon proper solution heat treatment and natural aging at room temperature, develop the properties specified in Table 4 or Table 5 for T42 temper material. The natural aging period at room temperature shall be not less than four days, but samples of material may be tested prior to four days aging, and if the material fails to conform to the requirements of T42 temper material, the tests may be repeated after completion of four days aging without prejudice.

TABLE 4 Tensile Property Limits for Heat-treatable Alloys, Inch-Pound Units<sup>A,B,N</sup>

Alloy	Temper	Specified Thickness, in.	Axis of Test Specimen <sup>C</sup>	Tensile Strength, ksi		Yield Strength (0.2 % offset), ksi		Elongation in 2 in. or 4x Diameter, min, %	Bend Diameter Factor, N
				min	max	min	max		
2014	O	0.020–0.124	...	...	32.0	...	16.0	16	0
2014	O	0.125–0.249	...	...	32.0	...	16.0	16	1
2014	O	0.250–0.499	...	...	32.0	...	16.0	16	2
2014	T3	0.020–0.039	...	59.0	...	35.0	...	14	3
2014	T3	0.040–0.124	...	59.0	...	36.0	...	14	3
2014	T3	0.125–0.249	...	59.0	...	36.0	...	14	4
2014	T4 <sup>D</sup>	0.020–0.124	...	59.0	...	35.0	...	14	3
2014	T4 <sup>D</sup>	0.125–0.249	...	59.0	...	35.0	...	14	4
2014	T42 <sup>E</sup>	0.020–0.124	...	58.0	...	34.0	...	14	3
2014	T42 <sup>E</sup>	0.125–0.249	...	58.0	...	34.0	...	14	4
2014	T42 <sup>E</sup>	0.250–0.499	...	58.0	...	34.0	...	14	5
2014	T42 <sup>E</sup>	0.500–1.000	...	58.0	...	34.0	...	14	...
2014	T451 <sup>F</sup>	0.250–1.000	...	58.0	...	36.0	...	14	...
2014	T451 <sup>F</sup>	1.001–2.000	...	58.0	...	36.0	...	12	...
2014	T451 <sup>F</sup>	2.001–3.000	...	57.0	...	36.0	...	8	...
2014	T6, T62 <sup>E</sup>	0.020–0.039	...	64.0	...	57.0	...	6	4
2014	T6, T62 <sup>E</sup>	0.040–0.050	...	66.0	...	58.0	...	7	5
2014	T6, T62 <sup>E</sup>	0.051–0.124	...	66.0	...	58.0	...	7	6
2014	T6, T62 <sup>E</sup>	0.125–0.249	...	66.0	...	58.0	...	7	8
2014	T62, <sup>E</sup> T651 <sup>F</sup>	0.250–0.499	...	67.0	...	59.0	...	7	10
2014	T62, <sup>E</sup> T651 <sup>F</sup>	0.500–1.000	...	67.0	...	59.0	...	6	...
2014	T62, <sup>E</sup> T651 <sup>F</sup>	1.001–2.000	...	67.0	...	59.0	...	4	...
2014	T62, <sup>E</sup> T651 <sup>F</sup>	2.001–2.500	...	65.0	...	58.0	...	2	...
2014	T62, <sup>E</sup> T651 <sup>F</sup>	2.501–3.000	...	63.0	...	57.0	...	2	...
2014	T62, <sup>E</sup> T651 <sup>F</sup>	3.001–4.000	...	59.0	...	55.0	...	1	...
2014	F <sup>G</sup>	0.250–1.000	...	...	...	...	...	...	...
Alclad 2014	O	0.020–0.499	...	...	30.0	...	14.0	16	...
Alclad 2014	O	0.500–1.000	...	...	32.0 <sup>H</sup>	...	...	10	...
Alclad 2014	T3	0.020–0.024	...	54.0	...	33.0	...	14	...
Alclad 2014	T3	0.025–0.039	...	55.0	...	34.0	...	14	...
Alclad 2014	T3	0.040–0.249	...	57.0	...	35.0	...	15	...
Alclad 2014	T4 <sup>D</sup>	0.020–0.024	...	54.0	...	31.0	...	14	...
Alclad 2014	T4 <sup>D</sup>	0.025–0.039	...	55.0	...	32.0	...	14	...
Alclad 2014	T4 <sup>D</sup>	0.040–0.249	...	57.0	...	34.0	...	15	...
Alclad 2014	T42 <sup>E</sup>	0.020–0.024	...	54.0	...	31.0	...	14	...
Alclad 2014	T42 <sup>E</sup>	0.025–0.039	...	55.0	...	32.0	...	14	...
Alclad 2014	T42 <sup>E</sup>	0.040–0.499	...	57.0	...	34.0	...	15	...
Alclad 2014	T42 <sup>E</sup>	0.500–1.000	...	58.0 <sup>H</sup>	...	34.0 <sup>H</sup>	...	14	...
Alclad 2014	T451 <sup>F</sup>	0.250–0.499	...	57.0	...	36.0	...	15	...
Alclad 2014	T451 <sup>F</sup>	0.500–1.000	...	58.0 <sup>H</sup>	...	36.0 <sup>H</sup>	...	14	...
Alclad 2014	T451 <sup>F</sup>	1.001–2.000	...	58.0 <sup>H</sup>	...	36.0 <sup>H</sup>	...	12	...
Alclad 2014	T451 <sup>F</sup>	2.001–3.000	...	57.0 <sup>H</sup>	...	36.0 <sup>H</sup>	...	8	...
Alclad 2014	T6, T62 <sup>E</sup>	0.020–0.024	...	62.0	...	54.0	...	7	...
Alclad 2014	T6, T62 <sup>E</sup>	0.025–0.039	...	63.0	...	55.0	...	7	...
Alclad 2014	T6, T62 <sup>E</sup>	0.040–0.249	...	64.0	...	57.0	...	8	...
Alclad 2014	T62, <sup>E</sup> T651 <sup>F</sup>	0.250–0.499	...	64.0	...	57.0	...	8	...
Alclad 2014	T62, <sup>E</sup> T651 <sup>F</sup>	0.500–1.000	...	67.0 <sup>H</sup>	...	59.0 <sup>H</sup>	...	6	...
Alclad 2014	T62, <sup>E</sup> T651 <sup>F</sup>	1.001–2.000	...	67.0 <sup>H</sup>	...	59.0 <sup>H</sup>	...	4	...
Alclad 2014	T62, <sup>E</sup> T651 <sup>F</sup>	2.001–2.500	...	65.0 <sup>H</sup>	...	58.0 <sup>H</sup>	...	2	...
Alclad 2014	T62, <sup>E</sup> T651 <sup>F</sup>	2.501–3.000	...	63.0 <sup>H</sup>	...	57.0 <sup>H</sup>	...	2	...
Alclad 2014	T62, <sup>E</sup> T651 <sup>F</sup>	3.001–4.000	...	59.0 <sup>H</sup>	...	55.0 <sup>H</sup>	...	1	...
Alclad 2014	F <sup>G</sup>	0.250–1.000	...	...	...	...	...	...	...
2024	O	0.010–0.032	...	...	32.0	...	14.0	12	0
2024	O	0.033–0.063	...	...	32.0	...	14.0	12	1
2024	O	0.064–0.128	...	...	32.0	...	14.0	12	4
2024	O	0.129–0.499	...	...	32.0	...	14.0	12	6
2024	T3	0.008–0.009	...	63.0	...	42.0	...	10	4
2024	T3	0.010–0.020	...	63.0	...	42.0	...	12	4
2024	T3	0.021–0.051	...	63.0	...	42.0	...	15	5
2024	T3	0.052–0.128	...	63.0	...	42.0	...	15	6
2024	T3	0.129–0.249	...	64.0	...	42.0	...	15	8
2024	T351 <sup>F</sup>	0.250–0.499	...	64.0	...	42.0	...	12	...
2024	T351 <sup>F</sup>	0.500–1.000	...	63.0	...	42.0	...	8	...
2024	T351 <sup>F</sup>	1.001–1.500	...	62.0	...	42.0	...	7	...
2024	T351 <sup>F</sup>	1.501–2.000	...	62.0	...	42.0	...	6	...
2024	T351 <sup>F</sup>	2.001–3.000	...	60.0	...	42.0	...	4	...
2024	T351 <sup>F</sup>	3.001–4.000	...	57.0	...	41.0	...	4	...
2024	T361 <sup>I</sup>	0.020–0.051	...	67.0	...	50.0	...	8	4

TABLE 4 Continued

Alloy	Temper	Specified Thickness, in.	Axis of Test Specimen <sup>C</sup>	Tensile Strength, ksi		Yield Strength (0.2 % offset), ksi		Elongation in 2 in. or 4x Diameter, min, %	Bend Diameter Factor, N
				min	max	min	max		
2024	T361 <sup>I</sup>	0.052–0.062	...	67.0	...	50.0	...	8	8
2024	T361 <sup>I</sup>	0.063–0.249	...	68.0	...	51.0	...	9	8
2024	T361 <sup>I</sup>	0.250–0.499	...	66.0	...	49.0	...	9	...
2024	T361 <sup>I</sup>	0.500	...	66.0	...	49.0	...	10	...
2024	T4 <sup>D</sup>	0.010–0.020	...	62.0	...	40.0	...	12	4
2024	T4 <sup>D</sup>	0.021–0.051	...	62.0	...	40.0	...	15	5
2024	T4 <sup>D</sup>	0.052–0.128	...	62.0	...	40.0	...	15	6
2024	T4 <sup>D</sup>	0.129–0.249	...	62.0	...	40.0	...	15	8
2024	T42 <sup>E</sup>	0.010–0.020	...	62.0	...	38.0	...	12	4
2024	T42 <sup>E</sup>	0.021–0.051	...	62.0	...	38.0	...	15	5
2024	T42 <sup>E</sup>	0.052–0.128	...	62.0	...	38.0	...	15	6
2024	T42 <sup>E</sup>	0.129–0.249	...	62.0	...	38.0	...	15	8
2024	T42 <sup>E</sup>	0.250–0.499	...	62.0	...	38.0	...	12	10
2024	T42 <sup>E</sup>	0.500–1.000	...	61.0	...	38.0	...	8	...
2024	T42 <sup>E</sup>	1.001–1.500	...	60.0	...	38.0	...	7	...
2024	T42 <sup>E</sup>	1.501–2.000	...	60.0	...	38.0	...	6	...
2024	T42 <sup>E</sup>	2.001–3.000	...	58.0	...	38.0	...	4	...
2024	T62 <sup>E</sup>	0.010–0.499	...	64.0	...	50.0	...	5	...
2024	T62 <sup>E</sup>	0.500–3.000	...	63.0	...	50.0	...	5	...
2024	T72 <sup>E,J</sup>	0.010–0.249	...	60.0	...	46.0	...	5	...
2024	T81	0.010–0.249	...	67.0	...	58.0	...	5	...
2024	T851 <sup>F</sup>	0.250–0.499	...	67.0	...	58.0	...	5	...
2024	T851 <sup>F</sup>	0.500–1.000	...	66.0	...	58.0	...	5	...
2024	T851 <sup>F</sup>	1.001–1.499	...	66.0	...	57.0	...	5	...
2024	T861 <sup>I</sup>	0.020–0.062	...	70.0	...	62.0	...	3	...
2024	T861 <sup>I</sup>	0.063–0.249	...	71.0	...	66.0	...	4	...
2024	T861 <sup>I</sup>	0.250–0.499	...	70.0	...	64.0	...	4	...
2024	T861 <sup>I</sup>	0.500	...	70.0	...	64.0	...	4	...
2024	F <sup>G</sup>	0.250–3.000	...	...	...	...	...	...	...
Alclad 2024	O	0.008–0.009	...	...	30.0	...	14.0	10	0
Alclad 2024	O	0.010–0.032	...	...	30.0	...	14.0	12	0
Alclad 2024	O	0.033–0.062	...	...	30.0	...	14.0	12	1
Alclad 2024	O	0.063–0.249	...	...	32.0	...	14.0	12	2
Alclad 2024	O	0.250–0.499	...	...	32.0	...	14.0	12	3
Alclad 2024	O	0.500–1.750	...	...	32.0 <sup>H</sup>	...	...	12	...
Alclad 2024	T3	0.008–0.009	...	58.0	...	39.0	...	10	4
Alclad 2024	T3	0.010–0.020	...	59.0	...	39.0	...	12	4
Alclad 2024	T3	0.021–0.040	...	59.0	...	39.0	...	15	4
Alclad 2024	T3	0.041–0.062	...	59.0	...	39.0	...	15	5
Alclad 2024	T3	0.063–0.128	...	61.0	...	40.0	...	15	5
Alclad 2024	T3	0.129–0.249	...	62.0	...	40.0	...	15	8
Alclad 2024	T351 <sup>F</sup>	0.250–0.499	...	62.0	...	40.0	...	12	...
Alclad 2024	T351 <sup>F</sup>	0.500–1.000	...	63.0 <sup>H</sup>	...	42.0 <sup>H</sup>	...	8	...
Alclad 2024	T351 <sup>F</sup>	1.001–1.500	...	62.0 <sup>H</sup>	...	42.0 <sup>H</sup>	...	7	...
Alclad 2024	T351 <sup>F</sup>	1.501–2.000	...	62.0 <sup>H</sup>	...	42.0 <sup>H</sup>	...	6	...
Alclad 2024	T351 <sup>F</sup>	2.001–3.000	...	60.0 <sup>H</sup>	...	42.0 <sup>H</sup>	...	4	...
Alclad 2024	T351 <sup>F</sup>	3.001–4.000	...	57.0 <sup>H</sup>	...	41.0 <sup>H</sup>	...	4	...
Alclad 2024	T361 <sup>I</sup>	0.020–0.062	...	61.0	...	47.0	...	8	4
Alclad 2024	T361 <sup>I</sup>	0.063–0.187	...	64.0	...	48.0	...	9	6
Alclad 2024	T361 <sup>I</sup>	0.188–0.249	...	64.0	...	48.0	...	9	8
Alclad 2024	T361 <sup>I</sup>	0.250–0.499	...	64.0	...	48.0	...	9	...
Alclad 2024	T361 <sup>I</sup>	0.500	...	66.0 <sup>H</sup>	...	49.0 <sup>H</sup>	...	10	...
Alclad 2024	T4 <sup>D</sup>	0.010–0.020	...	58.0	...	36.0	...	12	4
Alclad 2024	T4 <sup>D</sup>	0.021–0.040	...	58.0	...	36.0	...	15	4
Alclad 2024	T4 <sup>D</sup>	0.041–0.062	...	58.0	...	36.0	...	15	5
Alclad 2024	T4 <sup>D</sup>	0.063–0.128	...	61.0	...	38.0	...	15	5
Alclad 2024	T42 <sup>E</sup>	0.008–0.009	...	55.0	...	34.0	...	10	4
Alclad 2024	T42 <sup>E</sup>	0.010–0.020	...	57.0	...	34.0	...	12	4
Alclad 2024	T42 <sup>E</sup>	0.021–0.040	...	57.0	...	34.0	...	15	4
Alclad 2024	T42 <sup>E</sup>	0.041–0.062	...	57.0	...	34.0	...	15	5
Alclad 2024	T42 <sup>E</sup>	0.063–0.128	...	60.0	...	36.0	...	15	5
Alclad 2024	T42 <sup>E</sup>	0.129–0.187	...	60.0	...	36.0	...	15	8
Alclad 2024	T42 <sup>E</sup>	0.188–0.249	...	60.0	...	36.0	...	15	8
Alclad 2024	T42 <sup>E</sup>	0.250–0.499	...	60.0	...	36.0	...	12	10
Alclad 2024	T42 <sup>E</sup>	0.500–1.000	...	61.0 <sup>H</sup>	...	38.0 <sup>H</sup>	...	8	...
Alclad 2024	T42 <sup>E</sup>	1.001–1.500	...	60.0 <sup>H</sup>	...	38.0 <sup>H</sup>	...	7	...
Alclad 2024	T42 <sup>E</sup>	1.501–2.000	...	60.0 <sup>H</sup>	...	38.0 <sup>H</sup>	...	6	...
Alclad 2024	T42 <sup>E</sup>	2.001–3.000	...	58.0 <sup>H</sup>	...	38.0 <sup>H</sup>	...	4	...
Alclad 2024	T62 <sup>E</sup>	0.010–0.062	...	60.0	...	47.0	...	5	...
Alclad 2024	T62 <sup>E</sup>	0.063–0.499	...	62.0	...	49.0	...	5	...

TABLE 4 Continued

Alloy	Temper	Specified Thickness, in.	Axis of Test Specimen <sup>C</sup>	Tensile Strength, ksi		Yield Strength (0.2 % offset), ksi		Elongation in 2 in. or 4x Diameter, min, %	Bend Diameter Factor, <i>N</i>
				min	max	min	max		
Alclad 2024	T72 <sup>E,J</sup>	0.010–0.062	...	56.0	...	43.0	...	5	...
Alclad 2024	T72 <sup>E,J</sup>	0.063–0.249	...	58.0	...	45.0	...	5	...
Alclad 2024	T81	0.010–0.062	...	62.0	...	54.0	...	5	...
Alclad 2024	T81	0.063–0.249	...	65.0	...	56.0	...	5	...
Alclad 2024	T851 <sup>F</sup>	0.250–0.499	...	65.0	...	56.0	...	5	...
Alclad 2024	T851 <sup>F</sup>	0.500–1.000	...	66.0 <sup>H</sup>	...	58.0 <sup>H</sup>	...	5	...
Alclad 2024	T861 <sup>I</sup>	0.020–0.062	...	64.0	...	58.0	...	3	...
Alclad 2024	T861 <sup>I</sup>	0.063–0.187	...	69.0	...	64.0	...	4	...
Alclad 2024	T861 <sup>I</sup>	0.188–0.249	...	69.0	...	64.0	...	4	...
Alclad 2024	T861 <sup>I</sup>	0.250–0.499	...	68.0	...	62.0	...	4	...
Alclad 2024	T861 <sup>I</sup>	0.500	...	70.0 <sup>H</sup>	...	64.0 <sup>H</sup>	...	4	...
Alclad 2024	F <sup>G</sup>	0.250–3.000	...	...	...	...	...	...	...
1½ % Alclad 2024	O	0.188–0.499	...	...	32.0	...	14.0	12	...
1½ % Alclad 2024	O	0.500–1.750	...	...	32.0 <sup>H</sup>	...	...	12	...
1½ % Alclad 2024	T3	0.188–0.249	...	63.0	...	41.0	...	15	...
1½ % Alclad 2024	T361	0.188–0.249	...	65.0	...	49.0	...	9	...
1½ % Alclad 2024	T361	0.250–0.499	...	65.0	...	48.0	...	9	...
1½ % Alclad 2024	T361	0.500	...	66.0 <sup>H</sup>	...	49.0 <sup>H</sup>	...	10	...
1½ % Alclad 2024	T351 <sup>F</sup>	0.250–0.499	...	63.0	...	41.0	...	12	...
1½ % Alclad 2024	T351 <sup>F</sup>	0.500–1.000	...	63.0 <sup>H</sup>	...	42.0 <sup>H</sup>	...	8	...
1½ % Alclad 2024	T351 <sup>F</sup>	1.001–1.500	...	62.0 <sup>H</sup>	...	42.0 <sup>H</sup>	...	7	...
1½ % Alclad 2024	T351 <sup>F</sup>	1.501–2.000	...	62.0 <sup>H</sup>	...	42.0 <sup>H</sup>	...	6	...
1½ % Alclad 2024	T351 <sup>F</sup>	2.001–3.000	...	60.0 <sup>H</sup>	...	42.0 <sup>H</sup>	...	4	...
1½ % Alclad 2024	T351 <sup>F</sup>	3.001–4.000	...	57.0 <sup>H</sup>	...	41.0 <sup>H</sup>	...	4	...
1½ % Alclad 2024	T42 <sup>E</sup>	0.188–0.249	...	61.0	...	37.0	...	15	...
1½ % Alclad 2024	T42 <sup>E</sup>	0.250–0.499	...	61.0	...	37.0	...	12	...
1½ % Alclad 2024	T42 <sup>E</sup>	0.500–1.000	...	61.0 <sup>H</sup>	...	38.0 <sup>H</sup>	...	8	...
1½ % Alclad 2024	T42 <sup>E</sup>	1.001–1.500	...	60.0 <sup>H</sup>	...	38.0 <sup>H</sup>	...	7	...
1½ % Alclad 2024	T42 <sup>E</sup>	1.501–2.000	...	60.0 <sup>H</sup>	...	38.0 <sup>H</sup>	...	6	...
1½ % Alclad 2024	T42 <sup>E</sup>	2.001–3.000	...	58.0 <sup>H</sup>	...	38.0 <sup>H</sup>	...	4	...
1½ % Alclad 2024	T62 <sup>E</sup>	0.188–0.499	...	62.0	...	49.0	...	5	...
1½ % Alclad 2024	T72 <sup>E,J</sup>	0.188–0.249	...	59.0	...	45.0	...	5	...
1½ % Alclad 2024	T81	0.188–0.249	...	66.0	...	57.0	...	5	...
1½ % Alclad 2024	T851 <sup>F</sup>	0.250–0.499	...	66.0	...	57.0	...	5	...
1½ % Alclad 2024	T851 <sup>F</sup>	0.500–1.000	...	66.0 <sup>H</sup>	...	58.0 <sup>H</sup>	...	5	...
1½ % Alclad 2024	T861	0.188–0.249	...	70.0	...	65.0	...	4	...
1½ % Alclad 2024	T861	0.250–0.499	...	69.0	...	63.0	...	4	...
1½ % Alclad 2024	T861	0.500	...	70.0 <sup>H</sup>	...	64.0 <sup>H</sup>	...	4	...
1½ % Alclad 2024	F <sup>G</sup>	0.250–3.000	...	...	...	...	...	...	...
Alclad 1-Side 2024	O	0.008–0.009	...	...	31.0	...	14.0	10	...
Alclad 1-Side 2024	O	0.010–0.062	...	...	31.0	...	14.0	12	...
Alclad 1-Side 2024	O	0.063–0.499	...	...	32.0	...	14.0	12	...
Alclad 1-Side 2024	T3	0.010–0.020	...	61.0	...	40.0	...	12	...
Alclad 1-Side 2024	T3	0.021–0.062	...	61.0	...	40.0	...	15	...
Alclad 1-Side 2024	T3	0.063–0.128	...	62.0	...	41.0	...	15	...
Alclad 1-Side 2024	T3	0.129–0.249	...	63.0	...	41.0	...	15	...
Alclad 1-Side 2024	T351 <sup>F</sup>	0.250–0.499	...	63.0	...	41.0	...	12	...
Alclad 1-Side 2024	T361	0.020–0.062	...	64.0	...	48.0	...	8	...
Alclad 1-Side 2024	T361	0.063–0.249	...	66.0	...	49.0	...	9	...
Alclad 1-Side 2024	T361	0.250–0.499	...	65.0	...	48.0	...	9	...
Alclad 1-Side 2024	T42 <sup>E</sup>	0.010–0.020	...	59.0	...	35.0	...	12	...
Alclad 1-Side 2024	T42 <sup>E</sup>	0.021–0.062	...	59.0	...	36.0	...	15	...
Alclad 1-Side 2024	T42 <sup>E</sup>	0.063–0.249	...	61.0	...	37.0	...	15	...
Alclad 1-Side 2024	T42 <sup>E</sup>	0.250–0.499	...	61.0	...	37.0	...	12	...
Alclad 1-Side 2024	T62 <sup>E</sup>	0.010–0.062	...	62.0	...	48.0	...	5	...
Alclad 1-Side 2024	T62 <sup>E</sup>	0.063–0.499	...	63.0	...	49.0	...	5	...
Alclad 1-Side 2024	T72 <sup>E,J</sup>	0.010–0.062	...	58.0	...	44.0	...	5	...
Alclad 1-Side 2024	T72 <sup>E,J</sup>	0.063–0.249	...	59.0	...	45.0	...	5	...
Alclad 1-Side 2024	T81	0.010–0.062	...	64.0	...	56.0	...	5	...
Alclad 1-Side 2024	T81	0.063–0.249	...	66.0	...	57.0	...	5	...
Alclad 1-Side 2024	T851 <sup>F</sup>	0.250–0.499	...	66.0	...	57.0	...	5	...
Alclad 1-Side 2024	T861	0.020–0.062	...	67.0	...	60.0	...	3	...
Alclad 1-Side 2024	T861	0.063–0.249	...	70.0	...	65.0	...	4	...
Alclad 1-Side 2024	T861	0.250–0.499	...	69.0	...	63.0	...	4	...
Alclad 1-Side 2024	F <sup>G</sup>	0.250–0.499	...	...	...	...	...	...	...

TABLE 4 Continued

Alloy	Temper	Specified Thickness, in.	Axis of Test Specimen <sup>C</sup>	Tensile Strength, ksi		Yield Strength (0.2 % offset), ksi		Elongation in 2 in. or 4x Diameter, min, %	Bend Diameter Factor, N
				min	max	min	max		
1½ % Alclad 1-Side 2024	O	0.188–0.499	...	...	32.0	...	14.0	12	...
1½ % Alclad 1-Side 2024	T3	0.188–0.249	...	63.0	...	41.0	...	15	...
1½ % Alclad 1-Side 2024	T351 <sup>F</sup>	0.250–0.499	...	63.0	...	41.0	...	12	...
1½ % Alclad 1-Side 2024	T361	0.188–0.249	...	66.0	...	49.0	...	9	...
1½ % Alclad 1-Side 2024	T361	0.250–0.499	...	65.0	...	48.0	...	9	...
1½ % Alclad 1-Side 2024	T42 <sup>E</sup>	0.188–0.249	...	61.0	...	37.0	...	15	...
1½ % Alclad 1-Side 2024	T42 <sup>E</sup>	0.250–0.499	...	61.0	...	37.0	...	12	...
1½ % Alclad 1-Side 2024	T62 <sup>E</sup>	0.188–0.499	...	63.0	...	49.0	...	5	...
1½ % Alclad 1-Side 2024	T72 <sup>E,J</sup>	0.188–0.249	...	59.0	...	45.0	...	5	...
1½ % Alclad 1-Side 2024	T81	0.188–0.249	...	66.0	...	57.0	...	5	...
1½ % Alclad 1-Side 2024	T851 <sup>F</sup>	0.250–0.499	...	66.0	...	57.0	...	5	...
1½ % Alclad 1-Side 2024	T861	0.188–0.249	...	70.0	...	65.0	...	4	...
1½ % Alclad 1-Side 2024	T861	0.250–0.499	...	69.0	...	63.0	...	4	...
1½ % Alclad 1-Side 2024	F <sup>G</sup>	0.250–0.499	...	...	...	...	...	...	...
2124	T851 <sup>F</sup>	1.000–2.000 <sup>K</sup>	longitudinal	66.0	...	57.0	...	6	...
2124	T851 <sup>F</sup>	1.000–2.000 <sup>K</sup>	long	66.0	...	57.0	...	5	...
2124	T851 <sup>F</sup>	1.000–2.000 <sup>K</sup>	transverse short	64.0	...	55.0	...	1.5	...
2124	T851 <sup>F</sup>	2.001–3.000	longitudinal	65.0	...	57.0	...	6	...
2124	T851 <sup>F</sup>	2.001–3.000	long	65.0	...	57.0	...	4	...
2124	T851 <sup>F</sup>	2.001–3.000	transverse short	63.0	...	55.0	...	1.5	...
2124	T851 <sup>F</sup>	3.001–4.000	longitudinal	65.0	...	56.0	...	5	...
2124	T851 <sup>F</sup>	3.001–4.000	long	63.0	...	56.0	...	4	...
2124	T851 <sup>F</sup>	3.001–4.000	transverse short	62.0	...	54.0	...	1.5	...
2124	T851 <sup>F</sup>	4.001–5.000	longitudinal	64.0	...	55.0	...	5	...
2124	T851 <sup>F</sup>	4.001–5.000	long	64.0	...	55.0	...	4	...
2124	T851 <sup>F</sup>	4.001–5.000	transverse short	61.0	...	53.0	...	1.5	...
2124	T851 <sup>F</sup>	5.001–6.000	longitudinal	63.0	...	54.0	...	5	...
2124	T851 <sup>F</sup>	5.001–6.000	long	63.0	...	54.0	...	4	...
2124	T851 <sup>F</sup>	5.001–6.000	transverse short	58.0	...	51.0	...	1.5	...
2124	T851 <sup>F</sup>	5.001–6.000	transverse	...	...	...	...	...	...
2219	O	0.020–0.250	...	...	32.0	...	16.0	12	4
2219	O	0.251–0.750	...	...	32.0	...	16.0	12	6
2219	O	0.751–1.000	...	...	32.0	...	16.0	12	8
2219	O	1.001–2.000	...	...	32.0	...	16.0	12	...
2219	T31 <sup>L</sup> (flat sheet)	0.020–0.039	...	46.0	...	29.0	...	8	...
2219	T31 <sup>L</sup> (flat sheet)	0.040–0.249	...	46.0	...	28.0	...	10	...
2219	T351 <sup>F,L</sup> plate (formerly T31 plate)	0.250–2.000	...	46.0	...	28.0	...	10	...
2219	T351 <sup>F,L</sup> plate (formerly T31 plate)	2.001–3.000	...	44.0	...	28.0	...	10	...
2219	T351 <sup>F,L</sup> plate (formerly T31 plate)	3.001–4.000	...	42.0	...	27.0	...	9	...
2219	T351 <sup>F,L</sup> plate (formerly T31 plate)	4.001–5.000	...	40.0	...	26.0	...	9	...
2219	T351 <sup>F,L</sup> plate (formerly T31 plate)	5.001–6.000	...	39.0	...	25.0	...	8	...
2219	T37 <sup>L</sup>	0.020–0.039	...	49.0	...	38.0	...	6	...
2219	T37 <sup>L</sup>	0.040–2.500	...	49.0	...	37.0	...	6	...
2219	T37 <sup>L</sup>	2.501–3.000	...	47.0	...	36.0	...	6	...
2219	T37 <sup>L</sup>	3.001–4.000	...	45.0	...	35.0	...	5	...
2219	T37 <sup>L</sup>	4.001–5.000	...	43.0	...	34.0	...	4	...
2219	T62 <sup>E</sup>	0.020–0.039	...	54.0	...	36.0	...	6	...
2219	T62 <sup>E</sup>	0.040–0.249	...	54.0	...	36.0	...	7	...
2219	T62 <sup>E</sup>	0.250–1.000	...	54.0	...	36.0	...	8	...
2219	T62 <sup>E</sup>	1.001–2.000	...	54.0	...	36.0	...	7	...
2219	T81 sheet	0.020–0.039	...	62.0	...	46.0	...	6	...

TABLE 4 Continued

Alloy	Temper	Specified Thickness, in.	Axis of Test Specimen <sup>C</sup>	Tensile Strength, ksi		Yield Strength (0.2 % offset), ksi		Elongation in 2 in. or 4x Diameter, min, %	Bend Diameter Factor, <i>N</i>
				min	max	min	max		
2219	T81 sheet	0.040–0.249	...	62.0	...	46.0	...	7	...
2219	T851 <sup>F</sup> plate (formerly T81 plate)	0.250–1.000	...	62.0	...	46.0	...	8	...
2219	T851 <sup>F</sup> plate (formerly T81 plate)	1.001–2.000	...	62.0	...	46.0	...	7	...
2219	T851 <sup>F</sup> plate (formerly T81 plate)	2.001–3.000	...	62.0	...	45.0	...	6	...
2219	T851 <sup>F</sup> plate (formerly T81 plate)	3.001–4.000	...	60.0	...	44.0	...	5	...
2219	T851 <sup>F</sup> plate (formerly T81 plate)	4.001–5.000	...	59.0	...	43.0	...	5	...
2219	T851 <sup>F</sup> plate (formerly T81 plate)	5.001–6.000	...	57.0	...	42.0	...	4	...
2219	T87	0.020–0.039	...	64.0	...	52.0	...	5	...
2219	T87	0.040–0.249	...	64.0	...	52.0	...	6	...
2219	T87	0.250–1.000	...	64.0	...	51.0	...	7	...
2219	T87	1.001–2.000	...	64.0	...	51.0	...	6	...
2219	T87	2.001–3.000	...	64.0	...	51.0	...	6	...
2219	T87	3.001–4.000	...	62.0	...	50.0	...	4	...
2219	T87	4.001–5.000	...	61.0	...	49.0	...	3	...
2219	F <sup>G</sup>	0.250–2.000	...	...	...	...	...	...	...
Alclad 2219	O	0.020–0.499	...	...	32.0	...	16.0	12	...
Alclad 2219	O	0.500–2.000	...	...	32.0 <sup>H</sup>	...	16.0 <sup>H</sup>	...	...
Alclad 2219	T31 <sup>L</sup> (flat sheet)	0.040–0.099	...	42.0	...	25.0	...	10	...
Alclad 2219	T31 <sup>L</sup> (flat sheet)	0.100–0.249	...	44.0	...	26.0	...	10	...
Alclad 2219	T351 <sup>F,L</sup> plate (formerly T31 plate)	0.250–0.499	...	44.0	...	26.0	...	10	...
Alclad 2219	T37 <sup>L</sup>	0.040–0.099	...	45.0	...	34.0	...	6	...
Alclad 2219	T37 <sup>L</sup>	0.100–0.499	...	47.0	...	35.0	...	6	...
Alclad 2219	T62 <sup>E</sup>	0.020–0.039	...	44.0	...	29.0	...	6	...
Alclad 2219	T62 <sup>E</sup>	0.040–0.099	...	49.0	...	32.0	...	7	...
Alclad 2219	T62 <sup>E</sup>	0.100–0.249	...	51.0	...	34.0	...	7	...
Alclad 2219	T62 <sup>E</sup>	0.250–0.499	...	51.0	...	34.0	...	8	...
Alclad 2219	T62 <sup>E</sup>	0.500–1.000	...	54.0 <sup>H</sup>	...	36.0 <sup>H</sup>	...	8	...
Alclad 2219	T62 <sup>E</sup>	1.001–2.000	...	54.0 <sup>H</sup>	...	36.0 <sup>H</sup>	...	7	...
Alclad 2219	T81 (flat sheet)	0.020–0.039	...	49.0	...	37.0	...	6	...
Alclad 2219	T81 (flat sheet)	0.040–0.099	...	55.0	...	41.0	...	7	...
Alclad 2219	T81 (flat sheet)	0.100–0.249	...	58.0	...	43.0	...	7	...
Alclad 2219	T851 <sup>F</sup> plate (formerly T81 plate)	0.250–0.499	...	58.0	...	42.0	...	8	...
Alclad 2219	T87	0.040–0.099	...	57.0	...	46.0	...	6	...
Alclad 2219	T87	0.100–0.249	...	60.0	...	48.0	...	6	...
Alclad 2219	T87	0.250–0.499	...	60.0	...	48.0	...	7	...
Alclad 2219	F <sup>G</sup>	0.250–2.000	...	...	...	...	...	...	...
6013	T4	0.020–0.249	...	40.0	...	21.0	...	20	...
6013	T6	0.020–0.249	...	52.0	...	46.0	...	8	...
6013	T651	0.250–1.500	...	53.0	...	44.0	...	5	...
6013	T651	1.501–3.000	...	54.0	...	47.0	...	5	...
6013	T651	3.001–6.000	...	55.0	...	47.0	...	4	...
6061	O	0.006–0.007	...	...	22.0	...	12.0	10	0
6061	O	0.008–0.009	...	...	22.0	...	12.0	12	0
6061	O	0.010–0.020	...	...	22.0	...	12.0	14	0
6061	O	0.021–0.128	...	...	22.0	...	12.0	16	1
6061	O	0.129–0.249	...	...	22.0	...	12.0	18	2
6061	O	0.250–0.499	...	...	22.0	...	12.0	18	3
6061	O	0.500–1.000	...	...	22.0	...	...	18	...
6061	O	1.001–3.000	...	...	22.0	...	...	16	...
6061	T4	0.006–0.007	...	30.0	...	16.0	...	10	2
6061	T4	0.008–0.009	...	30.0	...	16.0	...	12	2
6061	T4	0.010–0.020	...	30.0	...	16.0	...	14	2
6061	T4	0.021–0.249	...	30.0	...	16.0	...	16	3
6061	T451 <sup>F</sup>	0.250–0.499	...	30.0	...	16.0	...	18	4

TABLE 4 Continued

Alloy	Temper	Specified Thickness, in.	Axis of Test Specimen <sup>C</sup>	Tensile Strength, ksi		Yield Strength (0.2 % offset), ksi		Elongation in 2 in. or 4x Diameter, min, %	Bend Diameter Factor, <i>N</i>
				min	max	min	max		
6061	T451 <sup>F</sup>	0.500–1.000	...	30.0	...	16.0	...	18	...
6061	T451 <sup>F</sup>	1.001–3.000	...	30.0	...	16.0	...	16	...
6061	T42 <sup>E</sup>	0.006–0.007	...	30.0	...	14.0	...	10	2
6061	T42 <sup>E</sup>	0.008–0.009	...	30.0	...	14.0	...	12	2
6061	T42 <sup>E</sup>	0.010–0.020	...	30.0	...	14.0	...	14	2
6061	T42 <sup>E</sup>	0.021–0.249	...	30.0	...	14.0	...	16	3
6061	T42 <sup>E</sup>	0.250–0.499	...	30.0	...	14.0	...	18	4
6061	T42 <sup>E</sup>	0.500–1.000	...	30.0	...	14.0	...	18	...
6061	T42 <sup>E</sup>	1.001–3.000	...	30.0	...	14.0	...	16	...
6061	T6, T62 <sup>E</sup>	0.006–0.007	...	42.0	...	35.0	...	4	2
6061	T6, T62 <sup>E</sup>	0.008–0.009	...	42.0	...	35.0	...	6	2
6061	T6, T62 <sup>E</sup>	0.010–0.020	...	42.0	...	35.0	...	8	2
6061	T6, T62 <sup>E</sup>	0.021–0.036	...	42.0	...	35.0	...	10	3
6061	T6, T62 <sup>E</sup>	0.037–0.064	...	42.0	...	35.0	...	10	4
6061	T6, T62 <sup>E</sup>	0.065–0.128	...	42.0	...	35.0	...	10	5
6061	T6, T62 <sup>E</sup>	0.129–0.249	...	42.0	...	35.0	...	10	6
6061	T62, <sup>E</sup> T651 <sup>F</sup>	0.250–0.499	...	42.0	...	35.0	...	10	7
6061	T62, <sup>E</sup> T651 <sup>F</sup>	0.500–1.000	...	42.0	...	35.0	...	9	...
6061	T62, <sup>E</sup> T651 <sup>F</sup>	1.001–2.000	...	42.0	...	35.0	...	8	...
6061	T62, <sup>E</sup> T651 <sup>F</sup>	2.001–4.000	...	42.0	...	35.0	...	6	...
6061	T62, <sup>E</sup> T651 <sup>F</sup>	4.001–6.000 <sup>M</sup>	...	40.0	...	35.0	...	6	...
6061	F <sup>G</sup>	0.250–3.000	...	...	...	...	...	...	...
Alclad 6061	O	0.010–0.020	...	...	20.0	...	12.0	14	...
Alclad 6061	O	0.021–0.128	...	...	20.0	...	12.0	16	...
Alclad 6061	O	0.129–0.499	...	...	20.0	...	12.0	18	...
Alclad 6061	O	0.500–1.000	...	...	22.0 <sup>H</sup>	...	...	18	...
Alclad 6061	O	1.001–3.000	...	...	22.0 <sup>H</sup>	...	...	16	...
Alclad 6061	T4	0.010–0.020	...	27.0	...	14.0	...	14	...
Alclad 6061	T4	0.021–0.249	...	27.0	...	14.0	...	16	...
Alclad 6061	T451 <sup>F</sup>	0.250–0.499	...	27.0	...	14.0	...	18	...
Alclad 6061	T451 <sup>F</sup>	0.500–1.000	...	30.0 <sup>H</sup>	...	16.0 <sup>H</sup>	...	18	...
Alclad 6061	T451 <sup>F</sup>	1.001–3.000	...	30.0 <sup>H</sup>	...	16.0 <sup>H</sup>	...	16	...
Alclad 6061	T42 <sup>E</sup>	0.010–0.020	...	27.0	...	12.0	...	14	...
Alclad 6061	T42 <sup>E</sup>	0.021–0.249	...	27.0	...	12.0	...	16	...
Alclad 6061	T42 <sup>E</sup>	0.250–0.499	...	27.0	...	12.0	...	18	...
Alclad 6061	T42 <sup>E</sup>	0.500–1.000	...	30.0 <sup>H</sup>	...	14.0 <sup>H</sup>	...	18	...
Alclad 6061	T42 <sup>E</sup>	1.001–3.000	...	30.0 <sup>H</sup>	...	14.0 <sup>H</sup>	...	16	...
Alclad 6061	T6, T62 <sup>E</sup>	0.010–0.020	...	38.0	...	32.0	...	8	...
Alclad 6061	T6, T62 <sup>E</sup>	0.021–0.249	...	38.0	...	32.0	...	10	...
Alclad 6061	T62, <sup>E</sup> T651 <sup>F</sup>	0.250–0.499	...	38.0	...	32.0	...	10	...
Alclad 6061	T62, <sup>E</sup> T651 <sup>F</sup>	0.500–1.000	...	42.0 <sup>H</sup>	...	35.0 <sup>H</sup>	...	9	...
Alclad 6061	T62, <sup>E</sup> T651 <sup>F</sup>	1.001–2.000	...	42.0 <sup>H</sup>	...	35.0 <sup>H</sup>	...	8	...
Alclad 6061	T62, <sup>E</sup> T651 <sup>F</sup>	2.001–4.000	...	42.0 <sup>H</sup>	...	35.0 <sup>H</sup>	...	6	...
Alclad 6061	T62, <sup>E</sup> T651 <sup>F</sup>	4.001–5.000	...	40.0 <sup>H</sup>	...	35.0 <sup>H</sup>	...	6	...
Alclad 6061	F <sup>G</sup>	0.250–3.000	...	...	...	...	...	...	...
7075	O	0.015–0.020	...	...	40.0	...	21.0	10	1
7075	O	0.021–0.062	...	...	40.0	...	21.0	10	2
7075	O	0.063–0.091	...	...	40.0	...	21.0	10	3
7075	O	0.092–0.125	...	...	40.0	...	21.0	10	4
7075	O	0.126–0.249	...	...	40.0	...	21.0	10	5
7075	O	0.250–0.499	...	...	40.0	...	21.0	10	6
7075	O	0.500–2.000	...	...	40.0	...	...	10	...
7075	T6, T62 <sup>E</sup>	0.008–0.011	...	74.0	...	63.0	...	5	7
7075	T6, T62 <sup>E</sup>	0.012–0.020	...	76.0	...	67.0	...	8	7
7075	T6, T62 <sup>E</sup>	0.021–0.039	...	76.0	...	67.0	...	8	8
7075	T6, T62 <sup>E</sup>	0.040–0.062	...	78.0	...	68.0	...	9	8
7075	T6, T62 <sup>E</sup>	0.063–0.091	...	78.0	...	68.0	...	9	9
7075	T6, T62 <sup>E</sup>	0.092–0.125	...	78.0	...	68.0	...	9	10
7075	T6, T62 <sup>E</sup>	0.126–0.187	...	79.0	...	69.0	...	9	11
7075	T6, T62 <sup>E</sup>	0.188–0.249	...	80.0	...	69.0	...	9	11
7075	T62, <sup>E</sup> T651 <sup>F</sup>	0.250–0.499	...	78.0	...	67.0	...	9	14
7075	T62, <sup>E</sup> T651 <sup>F</sup>	0.500–1.000	...	78.0	...	68.0	...	7	...
7075	T62, <sup>E</sup> T651 <sup>F</sup>	1.001–2.000	...	77.0	...	67.0	...	6	...
7075	T62, <sup>E</sup> T651 <sup>F</sup>	2.001–2.500	...	76.0	...	64.0	...	5	...
7075	T62, <sup>E</sup> T651 <sup>F</sup>	2.501–3.000	...	72.0	...	61.0	...	5	...
7075	T62, <sup>E</sup> T651 <sup>F</sup>	3.001–3.500	...	71.0	...	58.0	...	5	...
7075	T62, <sup>E</sup> T651 <sup>F</sup>	3.501–4.000	...	67.0	...	54.0	...	3	...
7075	T73 sheet	0.040–0.249	...	67.0	...	56.0	...	8	...

TABLE 4 Continued

Alloy	Temper	Specified Thickness, in.	Axis of Test Specimen <sup>C</sup>	Tensile Strength, ksi		Yield Strength (0.2 % offset), ksi		Elongation in 2 in. or 4x Diameter, min, %	Bend Diameter Factor, <i>N</i>
				min	max	min	max		
7075	T7351 <sup>F</sup> plate	0.250–1.000	...	69.0	...	57.0	...	7	...
7075	T7351 <sup>F</sup> plate	1.001–2.000	...	69.0	...	57.0	...	6	...
7075	T7351 <sup>F</sup> plate	2.001–2.500	...	66.0	...	52.0	...	6	...
7075	T7351 <sup>F</sup> plate	2.501–3.000	...	64.0	...	49.0	...	6	...
7075	T7351 <sup>F</sup> plate	3.001–3.500	...	63.0	...	49.0	...	6	...
7075	T7351 <sup>F</sup> plate	3.501–4.000	...	61.0	...	48.0	...	6	...
7075	T76 sheet	0.063–0.125	...	73.0	...	62.0	...	8	...
7075	T76 sheet	0.126–0.249	...	73.0	...	62.0	...	8	...
7075	T7651 plate <sup>F</sup>	0.250–0.499	...	72.0	...	61.0	...	8	...
7075	T7651 plate <sup>F</sup>	0.500–1.000	...	71.0	...	60.0	...	6	...
7075	T7651 plate <sup>F</sup>	1.001–2.000	...	71.0	...	60.0	...	5	...
7075	F <sup>G</sup>	0.250–4.000	...	...	...	...	...	...	...
Alclad 7075	O	0.008–0.014	...	...	36.0	...	20.0	9	1
Alclad 7075	O	0.015–0.032	...	...	36.0	...	20.0	10	1
Alclad 7075	O	0.033–0.062	...	...	36.0	...	20.0	10	2
Alclad 7075	O	0.063–0.125	...	...	38.0	...	20.0	10	3
Alclad 7075	O	0.126–0.187	...	...	38.0	...	20.0	10	4
Alclad 7075	O	0.188–0.249	...	...	39.0	...	21.0	10	4
Alclad 7075	O	0.250–0.499	...	...	39.0	...	21.0	10	6
Alclad 7075	O	0.500–1.000	...	...	40.0 <sup>H</sup>	...	...	10	...
Alclad 7075	T6, T62 <sup>E</sup>	0.008–0.011	...	68.0	...	58.0	...	5	6
Alclad 7075	T6, T62 <sup>E</sup>	0.012–0.020	...	71.0	...	61.0	...	8	6
Alclad 7075	T6, T62 <sup>E</sup>	0.021–0.039	...	71.0	...	61.0	...	8	7
Alclad 7075	T6, T62 <sup>E</sup>	0.040–0.062	...	72.0	...	62.0	...	9	7
Alclad 7075	T6, T62 <sup>E</sup>	0.063–0.091	...	74.0	...	64.0	...	9	8
Alclad 7075	T6, T62 <sup>E</sup>	0.092–0.125	...	74.0	...	64.0	...	9	9
Alclad 7075	T6, T62 <sup>E</sup>	0.126–0.187	...	74.0	...	64.0	...	9	10
Alclad 7075	T6, T62 <sup>E</sup>	0.188–0.249	...	76.0	...	65.0	...	9	10
Alclad 7075	T62, <sup>E</sup> T651 <sup>F</sup>	0.250–0.499	...	75.0	...	65.0	...	9	12
Alclad 7075	T62, <sup>E</sup> T651 <sup>F</sup>	0.500–1.000	...	78.0 <sup>H</sup>	...	68.0 <sup>H</sup>	...	7	...
Alclad 7075	T62, <sup>E</sup> T651 <sup>F</sup>	1.001–2.000	...	77.0 <sup>H</sup>	...	67.0 <sup>H</sup>	...	6	...
Alclad 7075	T62, <sup>E</sup> T651 <sup>F</sup>	2.001–2.500	...	76.0 <sup>H</sup>	...	64.0 <sup>H</sup>	...	5	...
Alclad 7075	T62, <sup>E</sup> T651 <sup>F</sup>	2.501–3.000	...	72.0 <sup>H</sup>	...	61.0 <sup>H</sup>	...	5	...
Alclad 7075	T62, <sup>E</sup> T651 <sup>F</sup>	3.001–3.500	...	71.0 <sup>H</sup>	...	58.0 <sup>H</sup>	...	5	...
Alclad 7075	T62, <sup>E</sup> T651 <sup>F</sup>	3.501–4.000	...	67.0 <sup>H</sup>	...	54.0 <sup>H</sup>	...	3	...
Alclad 7075	T76 sheet	0.040–0.062	...	67.0	...	56.0	...	8	...
Alclad 7075	T76 sheet	0.063–0.125	...	68.0	...	57.0	...	8	...
Alclad 7075	T76 sheet	0.126–0.187	...	68.0	...	57.0	...	8	...
Alclad 7075	T76 sheet	0.188–0.249	...	70.0	...	59.0	...	8	...
Alclad 7075	T7651 <sup>F</sup> plate	0.250–0.499	...	69.0	...	58.0	...	8	...
Alclad 7075	T7651 <sup>F</sup> plate	0.500–1.000	...	71.0 <sup>H</sup>	...	60.0 <sup>H</sup>	...	6	...
Alclad 7075	F <sup>G</sup>	0.250–4.000	...	...	...	...	...	...	...
Alclad 1-Side 7075	O	0.015–0.032	...	...	38.0	...	21.0	10	1
Alclad 1-Side 7075	O	0.033–0.062	...	...	38.0	...	21.0	10	2
Alclad 1-Side 7075	O	0.063–0.091	...	...	39.0	...	21.0	10	3
Alclad 1-Side 7075	O	0.092–0.125	...	...	39.0	...	21.0	10	4
Alclad 1-Side 7075	O	0.126–0.187	...	...	39.0	...	21.0	10	5
Alclad 1-Side 7075	O	0.188–0.249	...	...	39.0	...	21.0	10	5
Alclad 1-Side 7075	O	0.250–0.499	...	...	39.0	...	21.0	10	6
Alclad 1-Side 7075	O	0.500–1.000	...	...	40.0 <sup>H</sup>	...	...	10	...
Alclad 1-Side 7075	T6, T62 <sup>E</sup>	0.008–0.011	...	71.0	...	60.0	...	5	...
Alclad 1-Side 7075	T6, T62 <sup>E</sup>	0.012–0.014	...	74.0	...	64.0	...	8	...
Alclad 1-Side 7075	T6, T62 <sup>E</sup>	0.015–0.032	...	74.0	...	64.0	...	8	7
Alclad 1-Side 7075	T6, T62 <sup>E</sup>	0.033–0.039	...	74.0	...	64.0	...	8	8
Alclad 1-Side 7075	T6, T62 <sup>E</sup>	0.040–0.062	...	75.0	...	65.0	...	9	8
Alclad 1-Side 7075	T6, T62 <sup>E</sup>	0.063–0.091	...	76.0	...	66.0	...	9	9
Alclad 1-Side 7075	T6, T62 <sup>E</sup>	0.092–0.125	...	76.0	...	66.0	...	9	10
Alclad 1-Side 7075	T6, T62 <sup>E</sup>	0.126–0.187	...	77.0	...	67.0	...	9	11
Alclad 1-Side 7075	T6, T62 <sup>E</sup>	0.188–0.249	...	78.0	...	67.0	...	9	11
Alclad 1-Side 7075	T62, <sup>E</sup> T651 <sup>F</sup>	0.250–0.499	...	76.0	...	66.0	...	9	13
Alclad 1-Side 7075	T62, <sup>E</sup> T651 <sup>F</sup>	0.500–1.000	...	78.0 <sup>H</sup>	...	68.0 <sup>H</sup>	...	7	...
Alclad 1-Side 7075	T62, <sup>E</sup> T651 <sup>F</sup>	1.001–2.000	...	77.0 <sup>H</sup>	...	67.0 <sup>H</sup>	...	6	...
Alclad 1-Side 7075	F <sup>G</sup>	0.250–2.000	...	...	...	...	...	...	...

<sup>A</sup> To determine conformance to this specification, each value for tensile strength and yield strength shall be rounded to the nearest 0.1 ksi and each value for elongation to the nearest 0.5 %, both in accordance with the Rounding Method of Practice E29.

<sup>B</sup> The basis for establishment of mechanical property limits is shown in Annex A1.

<sup>C</sup> Long transverse unless otherwise noted.

<sup>D</sup> Coiled sheet.

<sup>E</sup> Material in the T42, T62, and T72 tempers is not available from the material producer.

<sup>F</sup> For stress-relieved tempers (T351, T451, T651, T7351, T7651, and T851), characteristics and properties other than those specified may differ somewhat from the corresponding characteristics and properties of material in the basic temper.

<sup>G</sup> Test for tensile properties in the F temper are not required.

<sup>H</sup> The tension test specimen from plate 0.500 in. and thicker is machined from the core and does not include the cladding.

<sup>I</sup> Applicable to flat sheet and plate only.

<sup>J</sup> The T72 temper is applicable only to Alloys 2024 and Alclad 2024 sheet solution heat treated and artificially overaged by the user to develop increased resistance to stress-corrosion cracking.

<sup>K</sup> Short transverse tensile property limits are not applicable to material less than 1.500 in. in thickness.

<sup>L</sup> Use of Alloys 2219 and Alclad 2219 in the T31, T351, and T37 tempers for finished products is not recommended.

<sup>M</sup> The properties for this thickness apply only to the T651 temper.

<sup>N</sup> Mechanical property requirements for product outside the gauge range covered by Table 4 shall be agreed upon between purchaser and producer.

10.2 Also, material in the O or F temper of alloys 2219, Alclad 2219, 6061, 7075, Alclad 7075, and Alclad one-side 7075 shall, upon proper solution heat treatment and precipitation heat treatment, develop the properties specified in Table 4 or Table 5 for T62 temper material.

10.3 *Number of Specimens*—The number of specimens from each lot of O temper material and F temper material to be tested to verify conformance with 10.1 and 10.2 shall be as specified in 9.2.

precipitation heat treatment, be capable of attaining the properties specified in Table 4 or Table 5 for the T62 temper.

Alloys	Tempers
2219 and Alclad 2219	T31, T351, T81, T851
7075	T6, T651, T73, T7351, T76, T7651
Alclad 7075	T6, T651, T76, T7651
Alclad 1-Side 7075	T6, T651

## 11. Heat Treatment and Reheat-treatment Capability

11.1 Mill-produced material in the O or F temper of alloys 2014, Alclad 2014, 2024, Alclad 2024, 1½ % Alclad 2024, Alclad one-side 2024, 1½ % Alclad one-side 2024, 6061, and Alclad 6061 (without the subsequent imposition of cold work or forming operations) shall, upon proper solution heat treatment and natural aging at room temperature, develop the properties specified in Table 4 or Table 5 for T42 temper material. The natural aging period at room temperature shall be not less than four days, but samples of material may be tested prior to four days aging, and if the material fails to conform to the requirements of T42 temper material, the tests may be repeated after completion of four days aging without prejudice.

11.2 Mill-produced material in the O or F temper of alloys 2219, Alclad 2219, 6061, 7075, Alclad 7075, and Alclad one-side 7075 (without the subsequent imposition of cold work or forming operations) shall, upon proper solution heat treatment and precipitation heat treatment, develop the properties specified in Table 4 or Table 5 for T62 temper material.

11.3 Mill-produced material in the following alloys and tempers shall, after proper resolution heat treatment and natural aging for four days at room temperature, be capable of attaining the properties specified in Table 4 or Table 5 for the T42 temper.

Alloys	Tempers
2014 and Alclad 2014	T3, T4, T451, T6, T651
2024 and Alclad 2024	T3, T4, T351, T81, T851
1½ % Alclad 2024, Alclad 1-Side 2024 and 1½ % Alclad 1-Side 2024	T3, T351, T81, T851

NOTE 6—Beginning with the 1974 revision, 6061 and Alclad 6061 T4, T451, T6, and T651 were deleted from this paragraph because experience has shown that reheat-treated material may develop large recrystallized grains and may fail to develop the tensile properties shown in Table 4 or Table 5.

11.4 Mill-produced material in the following alloys and tempers shall, after proper resolution heat treatment and

TABLE 5 Tensile Property Limits for Heat-treatable Alloys, SI Units<sup>A,B,M</sup>

Alloy	Temper	Specified Thickness, mm		Tensile Strength, MPa		Yield Strength (0.2% offset), MPa		Elongation, <sup>C</sup> min, %	
		over	through	min	max	min	max	in 50 mm	in 5x Diameter
2014	O	0.50	12.50	...	220	...	110	16	...
2014	O	12.50	25.00	...	220	...	...	...	9
2014	T3	0.50	1.00	405	...	240	...	14	...
2014	T3	1.00	6.30	405	...	250	...	14	...
2014	T4 <sup>D</sup>	0.50	6.30	405	...	240	...	14	...
2014	T451 <sup>E</sup>	6.30	12.50	400	...	250	...	14	...
2014	T451 <sup>E</sup>	12.50	25.00	400	...	250	...	...	12
2014	T451 <sup>E</sup>	25.00	50.00	400	...	250	...	...	10
2014	T451 <sup>E</sup>	50.00	80.00	395	...	250	...	...	7
2014	T42 <sup>F</sup>	0.50	12.50	400	...	235	...	14	...
2014	T42 <sup>F</sup>	12.50	25.00	400	...	235	...	...	12
2014	T6, T62 <sup>F</sup>	0.50	1.00	440	...	395	...	6	...
2014	T6, T62 <sup>F</sup>	1.00	6.30	455	...	400	...	7	...
2014	T6 <sup>F</sup> , T651 <sup>E</sup>	6.30	12.50	460	...	405	...	7	...
2014	T6 <sup>F</sup> , T651 <sup>E</sup>	12.50	25.00	460	...	405	...	...	5
2014	T6 <sup>F</sup> , T651 <sup>E</sup>	25.00	50.00	460	...	405	...	...	3
2014	T6 <sup>F</sup> , T651 <sup>E</sup>	50.00	60.00	450	...	400	...	...	1
2014	T6 <sup>F</sup> , T651 <sup>E</sup>	60.00	80.00	435	...	395	...	...	1
2014	T6 <sup>F</sup> , T651 <sup>E</sup>	80.00	100.00	405	...	380	...	...	...
2014	F <sup>G</sup>	6.30	25.00	...	...	...	...	...	...
Alclad 2014	O	0.50	0.63	...	205	...	95	16	...
Alclad 2014	O	0.63	1.00	...	205	...	95	16	...
Alclad 2014	O	1.00	2.50	...	205	...	95	16	...
Alclad 2014	O	2.50	12.50	...	205	...	95	16	...
Alclad 2014	O	12.50	25.00	...	220 <sup>H</sup>	...	...	...	9
Alclad 2014	T3	0.50	0.63	370	...	230	...	14	...
Alclad 2014	T3	0.63	1.00	380	...	235	...	14	...
Alclad 2014	T3	1.00	2.50	395	...	240	...	15	...
Alclad 2014	T3	2.50	6.30	395	...	240	...	15	...
Alclad 2014	T4 <sup>E</sup>	0.50	0.63	370	...	215	...	14	...
Alclad 2014	T4 <sup>E</sup>	0.63	1.00	380	...	220	...	14	...
Alclad 2014	T4 <sup>E</sup>	1.00	2.50	395	...	235	...	15	...
Alclad 2014	T4 <sup>E</sup>	2.50	6.30	395	...	235	...	15	...
Alclad 2014	T451 <sup>E</sup>	6.30	12.50	395	...	250	...	15	...
Alclad 2014	T451 <sup>E</sup>	12.50	25.00	400 <sup>H</sup>	...	250 <sup>H</sup>	...	...	12
Alclad 2014	T451 <sup>E</sup>	25.00	50.00	400 <sup>H</sup>	...	250 <sup>H</sup>	...	...	10
Alclad 2014	T451 <sup>E</sup>	50.00	80.00	395 <sup>H</sup>	...	250 <sup>H</sup>	...	...	7
Alclad 2014	T42 <sup>F</sup>	0.50	0.63	370	...	215	...	14	...
Alclad 2014	T42 <sup>F</sup>	0.63	1.00	380	...	220	...	14	...
Alclad 2014	T42 <sup>F</sup>	1.00	2.50	395	...	235	...	15	...
Alclad 2014	T42 <sup>F</sup>	2.50	12.50	395	...	235	...	15	...
Alclad 2014	T42 <sup>F</sup>	12.50	25.00	400 <sup>H</sup>	...	235 <sup>H</sup>	...	...	12
Alclad 2014	T6, T62 <sup>F</sup>	0.50	0.63	425	...	370	...	7	...
Alclad 2014	T6, T62 <sup>F</sup>	0.63	1.00	435	...	380	...	7	...
Alclad 2014	T6, T62 <sup>F</sup>	1.00	2.50	440	...	395	...	8	...
Alclad 2014	T6, T62 <sup>F</sup>	2.50	6.30	440	...	395	...	8	...
Alclad 2014	T62 <sup>F</sup> , T651 <sup>E</sup>	6.30	12.50	440	...	395	...	8	...
Alclad 2014	T62 <sup>F</sup> , T651 <sup>E</sup>	12.50	25.00	460 <sup>H</sup>	...	405 <sup>H</sup>	...	...	5
Alclad 2014	T62 <sup>F</sup> , T651 <sup>E</sup>	25.00	50.00	460 <sup>H</sup>	...	405 <sup>H</sup>	...	...	3
Alclad 2014	T62 <sup>F</sup> , T651 <sup>E</sup>	50.00	60.00	450 <sup>H</sup>	...	400 <sup>H</sup>	...	...	1
Alclad 2014	T62 <sup>F</sup> , T651 <sup>E</sup>	60.00	80.00	435 <sup>H</sup>	...	395 <sup>H</sup>	...	...	1
Alclad 2014	T62 <sup>F</sup> , T651 <sup>E</sup>	80.00	100.00	405 <sup>H</sup>	...	380 <sup>H</sup>	...	...	...
Alclad 2014	F <sup>G</sup>	6.30	25.00	...	...	...	...	...	...
2024	O	0.24	12.50	...	220	...	95	12	...
2024	O	12.50	45.00	...	220	...	...	...	10
2024	T3	0.19	0.25	435	...	290	...	10	...
2024	T3	0.25	0.50	435	...	290	...	12	...
2024	T3	0.50	3.20	435	...	290	...	15	...
2024	T3	3.20	6.30	435	...	290	...	15	...
2024	T351 <sup>E</sup>	6.30	12.50	440	...	290	...	12	...
2024	T351 <sup>E</sup>	12.50	25.00	435	...	290	...	...	7
2024	T351 <sup>E</sup>	25.00	40.00	425	...	290	...	...	6
2024	T351 <sup>E</sup>	40.00	50.00	425	...	290	...	...	5
2024	T351 <sup>E</sup>	50.00	80.00	415	...	290	...	...	3
2024	T351 <sup>E</sup>	80.00	100.00	395	...	285	...	...	3
2024	T361	0.50	1.60	460	...	345	...	8	...
2024	T361	1.60	6.30	470	...	350	...	9	...
2024	T361	6.30	12.50	455	...	340	...	9	...

TABLE 5 Continued

Alloy	Temper	Specified Thickness, mm		Tensile Strength, MPa		Yield Strength (0.2 % offset), MPa		Elongation, <sup>C</sup> min, %	
		over	through	min	max	min	max	in 50 mm	in 5x Diameter
2024	T361	12.50	12.70	455	...	340	...	...	9
2024	T4 <sup>D</sup>	0.24	0.50	425	...	275	...	12	...
2024	T4 <sup>D</sup>	0.50	6.30	425	...	275	...	15	...
2024	T42 <sup>F</sup>	0.24	0.50	425	...	260	...	12	...
2024	T42 <sup>F</sup>	0.50	6.30	425	...	260	...	15	...
2024	T42 <sup>F</sup>	6.30	12.50	425	...	260	...	12	...
2024	T42 <sup>F</sup>	12.50	25.00	420	...	260	...	...	7
2024	T42 <sup>F</sup>	25.00	40.00	415	...	260	...	...	6
2024	T42 <sup>F</sup>	40.00	50.00	415	...	260	...	...	5
2024	T42 <sup>F</sup>	50.00	80.00	400	...	260	...	...	3
2024	T62 <sup>F</sup>	0.24	12.50	440	...	345	...	...	5
2024	T62 <sup>F</sup>	12.50	80.00	435	...	345	...	...	4
2024	T72 <sup>F,I</sup>	0.24	6.30	415	...	315	...	5	...
2024	T81	0.24	6.30	460	...	400	...	5	...
2024	T851 <sup>E</sup>	6.30	12.50	460	...	400	...	5	...
2024	T851 <sup>E</sup>	12.50	25.00	455	...	400	...	...	4
2024	T851 <sup>E</sup>	25.00	40.00	455	...	395	...	...	4
2024	T861	0.50	1.60	480	...	425	...	3	...
2024	T861	1.60	6.30	490	...	455	...	4	...
2024	T861	6.30	12.50	480	...	440	...	4	...
2024	T861	12.50	12.70	480	...	440	...	...	3
2024	F <sup>G</sup>	6.30	80.00	...	...	...	...	...	...
Alclad 2024	O	0.19	0.25	...	205	...	95	10	...
Alclad 2024	O	0.25	1.60	...	205	...	95	12	...
Alclad 2024	O	1.60	12.50	...	220	...	95	12	...
Alclad 2024	O	12.50	45.00	...	220 <sup>H</sup>	...	...	...	10
Alclad 2024	T3	0.19	0.25	400	...	270	...	10	...
Alclad 2024	T3	0.25	0.50	405	...	270	...	12	...
Alclad 2024	T3	0.50	1.60	405	...	270	...	15	...
Alclad 2024	T3	1.60	3.20	420	...	275	...	15	...
Alclad 2024	T3	3.20	6.30	420	...	275	...	15	...
Alclad 2024	T351 <sup>E</sup>	6.30	12.50	425	...	275	...	12	...
Alclad 2024	T351 <sup>E</sup>	12.50	25.00	435 <sup>H</sup>	...	290 <sup>H</sup>	...	...	7
Alclad 2024	T351 <sup>E</sup>	25.00	40.00	425 <sup>H</sup>	...	290 <sup>H</sup>	...	...	6
Alclad 2024	T351 <sup>E</sup>	40.00	50.00	425 <sup>H</sup>	...	290 <sup>H</sup>	...	...	5
Alclad 2024	T351 <sup>E</sup>	50.00	80.00	415 <sup>H</sup>	...	290 <sup>H</sup>	...	...	3
Alclad 2024	T351 <sup>E</sup>	80.00	100.00	395 <sup>H</sup>	...	285 <sup>H</sup>	...	...	3
Alclad 2024	T361	0.50	1.60	420	...	325	...	8	...
Alclad 2024	T361	1.60	6.30	440	...	330	...	9	...
Alclad 2024	T361	6.30	12.50	440	...	330	...	9	...
Alclad 2024	T361	12.50	12.70	455 <sup>H</sup>	...	340 <sup>H</sup>	...	...	9
Alclad 2024	T4 <sup>D</sup>	0.24	0.50	400	...	245	...	12	...
Alclad 2024	T4 <sup>D</sup>	0.50	1.60	400	...	245	...	15	...
Alclad 2024	T4 <sup>D</sup>	1.60	3.20	420	...	260	...	15	...
Alclad 2024	T42 <sup>F</sup>	0.19	0.25	380	...	235	...	10	...
Alclad 2024	T42 <sup>F</sup>	0.25	0.50	395	...	235	...	12	...
Alclad 2024	T42 <sup>F</sup>	0.50	1.60	395	...	235	...	15	...
Alclad 2024	T42 <sup>F</sup>	1.60	6.30	415	...	250	...	15	...
Alclad 2024	T42 <sup>F</sup>	6.30	12.50	415	...	250	...	12	...
Alclad 2024	T42 <sup>F</sup>	12.50	25.00	420 <sup>H</sup>	...	260 <sup>H</sup>	...	...	7
Alclad 2024	T42 <sup>F</sup>	25.00	40.00	415 <sup>H</sup>	...	260 <sup>H</sup>	...	...	6
Alclad 2024	T42 <sup>F</sup>	40.00	50.00	415 <sup>H</sup>	...	260 <sup>H</sup>	...	...	5
Alclad 2024	T42 <sup>F</sup>	50.00	80.00	400 <sup>H</sup>	...	260 <sup>H</sup>	...	...	3
Alclad 2024	T62 <sup>F</sup>	0.24	1.60	415	...	325	...	5	...
Alclad 2024	T62 <sup>F</sup>	1.60	12.50	425	...	335	...	5	...
Alclad 2024	T72 <sup>F,I</sup>	0.24	1.60	385	...	295	...	5	...
Alclad 2024	T72 <sup>F,I</sup>	1.60	6.30	400	...	310	...	5	...
Alclad 2024	T81	0.24	1.60	425	...	370	...	5	...
Alclad 2024	T81	1.60	6.30	445	...	385	...	5	...
Alclad 2024	T851 <sup>E</sup>	6.30	12.50	445	...	385	...	5	...
Alclad 2024	T851 <sup>E</sup>	12.50	25.00	455 <sup>H</sup>	...	400 <sup>H</sup>	...	...	4
Alclad 2024	T861	0.50	1.60	440	...	400	...	3	...
Alclad 2024	T861	1.60	6.30	475	...	440	...	4	...
Alclad 2024	T861	6.30	12.50	470	...	425	...	4	...
Alclad 2024	T861	12.50	12.70	480 <sup>H</sup>	...	440 <sup>H</sup>	...	...	3
Alclad 2024	F <sup>G</sup>	6.30	80.00	...	...	...	...	...	...

TABLE 5 Continued

Alloy	Temper	Specified Thickness, mm		Tensile Strength, MPa		Yield Strength (0.2 % offset), MPa		Elongation, <sup>C</sup> min, %	
		over	through	min	max	min	max	in 50 mm	in 5x Diameter
1½ % Alclad 2024	O	4.00	12.50	...	220	...	95	12	...
1½ % Alclad 2024	O	12.50	45.00	...	220 <sup>H</sup>	...	...	...	10
1½ % Alclad 2024	T3	4.00	6.30	430	...	285	...	15	...
1½ % Alclad 2024	T351 <sup>E</sup>	6.30	12.50	435	...	285	...	12	...
1½ % Alclad 2024	T351 <sup>E</sup>	12.50	25.00	435 <sup>H</sup>	...	290 <sup>H</sup>	...	...	7
1½ % Alclad 2024	T351 <sup>E</sup>	25.00	40.00	425 <sup>H</sup>	...	290 <sup>H</sup>	...	...	6
1½ % Alclad 2024	T351 <sup>E</sup>	40.00	50.00	425 <sup>H</sup>	...	290 <sup>H</sup>	...	...	5
1½ % Alclad 2024	T351 <sup>E</sup>	50.00	80.00	415 <sup>H</sup>	...	290 <sup>H</sup>	...	...	3
1½ % Alclad 2024	T351 <sup>E</sup>	80.00	100.00	395 <sup>H</sup>	...	285 <sup>H</sup>	...	...	3
1½ % Alclad 2024	T361	4.00	6.30	450	...	340	...	9	...
1½ % Alclad 2024	T361	6.30	12.50	450	...	330	...	9	...
1½ % Alclad 2024	T361	12.50	12.70	455 <sup>H</sup>	...	340 <sup>H</sup>	...	...	9
1½ % Alclad 2024	T42 <sup>F</sup>	4.00	6.30	420	...	255	...	15	...
1½ % Alclad 2024	T42 <sup>F</sup>	6.30	12.50	420	...	255	...	12	...
1½ % Alclad 2024	T42 <sup>F</sup>	12.50	25.00	420 <sup>H</sup>	...	260 <sup>H</sup>	...	...	7
1½ % Alclad 2024	T42 <sup>F</sup>	25.00	40.00	415 <sup>H</sup>	...	260 <sup>H</sup>	...	...	6
1½ % Alclad 2024	T42 <sup>F</sup>	40.00	50.00	415 <sup>H</sup>	...	260 <sup>H</sup>	...	...	5
1½ % Alclad 2024	T42 <sup>F</sup>	50.00	80.00	400 <sup>H</sup>	...	260 <sup>H</sup>	...	...	3
1½ % Alclad 2024	T62 <sup>F</sup>	4.00	12.50	425	...	340	...	5	...
1½ % Alclad 2024	T72 <sup>F,I</sup>	4.00	6.30	405	...	310	...	5	...
1½ % Alclad 2024	T81	4.00	6.30	455	...	395	...	5	...
1½ % Alclad 2024	T851 <sup>E</sup>	6.30	12.50	455	...	395	...	5	...
1½ % Alclad 2024	T851 <sup>E</sup>	12.50	25.00	455 <sup>H</sup>	...	400 <sup>H</sup>	...	...	4
1½ % Alclad 2024	T861	4.00	6.30	480	...	450	...	4	...
1½ % Alclad 2024	T861	6.30	12.50	475	...	435	...	4	...
1½ % Alclad 2024	T861	12.50	12.70	480 <sup>H</sup>	...	440 <sup>H</sup>	...	...	3
1½ % Alclad 2024	F <sup>G</sup>	6.30	80.00	...	...	...	...	...	...
Alclad 1-Side 2024	O	0.19	0.25	...	215	...	95	10	...
Alclad 1-Side 2024	O	0.25	1.60	...	215	...	95	12	...
Alclad 1-Side 2024	O	1.60	12.50	...	220	...	95	12	...
Alclad 1-Side 2024	T3	0.24	0.50	420	...	275	...	12	...
Alclad 1-Side 2024	T3	0.50	1.60	420	...	275	...	15	...
Alclad 1-Side 2024	T3	1.60	3.20	425	...	285	...	15	...
Alclad 1-Side 2024	T3	3.20	6.30	430	...	285	...	15	...
Alclad 1-Side 2024	T351 <sup>E</sup>	6.30	12.50	435	...	285	...	12	...
Alclad 1-Side 2024	T361	0.50	1.00	440	...	330	...	8	...
Alclad 1-Side 2024	T361	1.60	6.30	455	...	340	...	9	...
Alclad 1-Side 2024	T361	6.30	12.50	450	...	330	...	9	...
Alclad 1-Side 2024	T42 <sup>F</sup>	0.24	0.50	405	...	240	...	12	...
Alclad 1-Side 2024	T42 <sup>F</sup>	0.50	1.60	405	...	250	...	15	...
Alclad 1-Side 2024	T42 <sup>F</sup>	1.60	6.30	420	...	255	...	15	...
Alclad 1-Side 2024	T42 <sup>F</sup>	6.30	12.50	420	...	255	...	12	...
Alclad 1-Side 2024	T62 <sup>F</sup>	0.24	1.60	425	...	330	...	5	...
Alclad 1-Side 2024	T62 <sup>F</sup>	1.60	12.50	435	...	340	...	5	...
Alclad 1-Side 2024	T72 <sup>F,I</sup>	0.24	1.60	400	...	305	...	5	...
Alclad 1-Side 2024	T72 <sup>F,I</sup>	1.60	6.30	405	...	310	...	5	...
Alclad 1-Side 2024	T81	0.24	1.60	440	...	385	...	5	...
Alclad 1-Side 2024	T81	1.60	6.30	455	...	395	...	5	...
Alclad 1-Side 2024	T851 <sup>E</sup>	6.30	12.50	455	...	395	...	5	...
Alclad 1-Side 2024	T861	0.50	1.60	460	...	415	...	3	...
Alclad 1-Side 2024	T861	1.60	6.30	485	...	450	...	4	...
Alclad 1-Side 2024	T861	6.30	12.50	475	...	435	...	4	...
Alclad 1-Side 2024	F <sup>G</sup>	6.30	12.50	...	...	...	...	...	...
1½ % Alclad 1-Side 2024	O	4.00	12.50	...	220	...	95	12	...
1½ % Alclad 1-Side 2024	T3	4.00	6.30	430	...	285	...	15	...
1½ % Alclad 1-Side 2024	T351 <sup>E</sup>	6.30	12.50	435	...	285	...	12	...
1½ % Alclad 1-Side 2024	T361	4.00	6.30	455	...	340	...	9	...
1½ % Alclad 1-Side 2024	T361	6.30	12.50	450	...	330	...	9	...
1½ % Alclad 1-Side 2024	T42 <sup>F</sup>	4.00	6.30	420	...	255	...	15	...
1½ % Alclad 1-Side 2024	T42 <sup>F</sup>	6.30	12.50	420	...	255	...	12	...
1½ % Alclad 1-Side 2024	T62 <sup>F</sup>	4.00	12.50	435	...	340	...	5	...
1½ % Alclad 1-Side 2024	T72 <sup>F,I</sup>	4.00	6.30	405	...	310	...	5	...
1½ % Alclad 1-Side 2024	T81	4.00	6.30	455	...	395	...	5	...
1½ % Alclad 1-Side 2024	T851 <sup>E</sup>	6.30	12.50	455	...	395	...	5	...
1½ % Alclad 1-Side 2024	T861	4.00	6.30	480	...	450	...	4	...
1½ % Alclad 1-Side 2024	T861	6.30	12.50	475	...	435	...	4	...
1½ % Alclad 1-Side 2024	F <sup>G</sup>	6.30	12.50	...	...	...	...	...	...

TABLE 5 Continued

Alloy	Temper	Specified Thickness, mm		Axis of Test Specimen	Tensile Strength, MPa		Yield Strength (0.2 % offset), MPa		Elongation, <sup>C</sup> min, %	
		over	through		min	max	min	max	in 50 mm	in 5x Diameter
2124	T851 <sup>E</sup>	25.00	50.00	longitudinal	455	...	395	...	...	5
2124	T851 <sup>E</sup>			long transverse	455	...	395	...	...	4
2124	T851 <sup>E</sup>			short transverse	440 <sup>J</sup>	...	380 <sup>J</sup>	...	...	1
2124	T851 <sup>E</sup>	50.00	80.00	longitudinal	450	...	395	...	...	5
2124	T851 <sup>E</sup>			long transverse	450	...	395	...	...	3
2124	T851 <sup>E</sup>			short transverse	435	...	380	...	...	1
2124	T851 <sup>E</sup>	80.00	100.00	longitudinal	450	...	385	...	...	4
2124	T851 <sup>E</sup>			long transverse	450	...	385	...	...	3
2124	T851 <sup>E</sup>			short transverse	425	...	370	...	...	1
2124	T851 <sup>E</sup>	100.00	130.00	longitudinal	440	...	380	...	...	4
2124	T851 <sup>E</sup>			long transverse	440	...	380	...	...	3
2124	T851 <sup>E</sup>			short transverse	420	...	365	...	...	1
2124	T851 <sup>E</sup>	130.00	150.00	longitudinal	435	...	370	...	...	4
2124	T851 <sup>E</sup>			long transverse	435	...	370	...	...	3
2124	T851 <sup>E</sup>			short transverse	400	...	350	...	...	1

Alloy	Temper	Specified Thickness, mm		Tensile Strength, MPa	Yield Strength (0.2 % offset), MPa	Elongation, <sup>C</sup> min, %			
		over	through			min	max	in 50 mm	in 5x Diameter
2219	O	0.50	12.50	...	220	...	110	12	...
2219	O	12.50	50.00	...	220	...	110	...	10
2219	T31 <sup>K</sup> (flat sheet)	0.50	1.00	315	...	200	...	8	...
2219	T31 <sup>K</sup> (flat sheet)	1.00	6.30	315	...	195	...	10	...
2219	T351 <sup>E,H</sup> plate (formerly T31 plate)	6.30	12.50	315	...	195	...	10	...
2219	T351 <sup>E,H</sup> plate (formerly T31 plate)	12.50	50.00	315	...	195	...	...	9
2219	T351 <sup>E,H</sup> plate (formerly T31 plate)	50.00	80.00	305	...	195	...	...	9
2219	T351 <sup>E,H</sup> plate (formerly T31 plate)	80.00	100.00	290	...	185	...	...	8
2219	T351 <sup>E,H</sup> plate (formerly T31 plate)	100.00	130.00	275	...	180	...	...	8
2219	T351 <sup>E,H</sup> plate (formerly T31 plate)	130.00	150.00	270	...	170	...	...	7
2219	T37 <sup>K</sup>	0.50	1.00	340	...	260	...	6	...
2219	T37 <sup>K</sup>	1.00	12.50	340	...	255	...	6	...
2219	T37 <sup>K</sup>	12.50	60.00	340	...	255	...	...	5
2219	T37 <sup>K</sup>	60.00	80.00	325	...	250	...	...	5
2219	T37 <sup>K</sup>	80.00	100.00	310	...	240	...	...	4
2219	T37 <sup>K</sup>	100.00	120.00	295	...	235	...	...	3
2219	T62 <sup>F</sup>	0.50	1.00	370	...	250	...	6	...
2219	T62 <sup>F</sup>	1.00	6.30	370	...	250	...	7	...
2219	T62 <sup>F</sup>	6.30	12.50	370	...	250	...	8	...
2219	T62 <sup>F</sup>	12.50	25.00	370	...	250	...	...	7
2219	T62 <sup>F</sup>	25.00	50.00	370	...	250	...	...	6
2219	T81 sheet	0.50	1.00	425	...	315	...	6	...
2219	T81 sheet	1.00	6.30	425	...	315	...	7	...
2219	T851 <sup>E</sup> (formerly T81 plate)	6.30	12.50	425	...	315	...	8	...
2219	T851 <sup>E</sup> (formerly T81 plate)	12.50	25.00	425	...	315	...	...	7
2219	T851 <sup>E</sup> (formerly T81 plate)	25.00	50.00	425	...	315	...	...	6

TABLE 5 Continued

Alloy	Temper	Specified Thickness, mm		Tensile Strength, MPa		Yield Strength (0.2 % offset), MPa		Elongation, <sup>C</sup> min, %	
		over	through	min	max	min	max	in 50 mm	in 5x Diameter
2219	T851 <sup>E</sup> (formerly T81 plate)	50.00	80.00	425	...	310	...	...	5
2219	T851 <sup>E</sup> (formerly T81 plate)	80.00	100.00	415	...	305	...	...	4
2219	T851 <sup>E</sup> (formerly T81 plate)	100.00	130.00	405	...	295	...	...	4
2219	T851 <sup>E</sup> (formerly T81 plate)	130.00	150.00	395	...	290	...	...	3
2219	T87	0.50	1.00	440	...	360	...	5	...
2219	T87	1.00	6.30	440	...	360	...	6	...
2219	T87	6.30	12.50	440	...	350	...	7	...
2219	T87	12.50	25.00	440	...	350	...	...	6
2219	T87	25.00	80.00	440	...	350	...	...	5
2219	T87	80.00	100.00	425	...	345	...	...	3
2219	T87	100.00	120.00	420	...	340	...	...	2
2219	F <sup>G</sup>	6.30	50.00	...	...	...	...	...	...
Alclad 2219	O	0.50	1.00	...	220	...	110	12	...
Alclad 2219	O	1.00	2.50	...	220	...	110	12	...
Alclad 2219	O	2.50	12.50	...	220	...	110	12	...
Alclad 2219	O	12.50	50.00	...	220 <sup>H</sup>	...	110 <sup>H</sup>	...	10
Alclad 2219	T31 <sup>K</sup> (flat sheet)	1.00	2.50	290	...	170	...	10	...
Alclad 2219	T31 <sup>K</sup> (flat sheet)	2.50	6.30	305	...	180	...	10	...
Alclad 2219	T351 <sup>E,K</sup> plate (formerly T31 plate)	6.30	12.50	305	...	180	...	10	...
Alclad 2219	T37 <sup>K</sup>	1.00	2.50	310	...	235	...	6	...
Alclad 2219	T37 <sup>K</sup>	2.50	12.50	325	...	240	...	6	...
Alclad 2219	T62 <sup>F</sup>	0.50	1.00	305	...	200	...	6	...
Alclad 2219	T62 <sup>F</sup>	1.00	2.50	340	...	220	...	7	...
Alclad 2219	T62 <sup>F</sup>	2.50	6.30	350	...	235	...	7	...
Alclad 2219	T62 <sup>F</sup>	6.30	12.50	350	...	235	...	8	...
Alclad 2219	T62 <sup>F</sup>	12.50	25.00	370 <sup>H</sup>	...	250 <sup>H</sup>	...	...	7
Alclad 2219	T62 <sup>F</sup>	25.00	50.00	370 <sup>H</sup>	...	250 <sup>H</sup>	...	...	6
Alclad 2219	T81 (flat sheet)	0.50	1.00	340	...	255	...	6	...
Alclad 2219	T81 (flat sheet)	1.00	2.50	380	...	285	...	7	...
Alclad 2219	T81 (flat sheet)	2.50	6.30	400	...	295	...	7	...
Alclad 2219	T851 <sup>E</sup> plate (formerly T81 plate)	6.30	12.50	400	...	290	...	8	...
Alclad 2219	T87	1.00	2.50	395	...	315	...	6	...
Alclad 2219	T87	2.50	6.30	415	...	330	...	6	...
Alclad 2219	T87	6.30	12.50	415	...	330	...	7	...
Alclad 2219	F <sup>G</sup>	6.30	50.00	...	...	...	...	...	...
6013	T4	0.50	6.30	275	...	145	...	20	...
6013	T6	0.50	6.30	360	...	315	...	8	...
6013	T651 <sup>E</sup>	6.30	40.00	365	...	305	...	...	4
6013	T651 <sup>E</sup>	40.00	80.00	370	...	325	...	...	4
6013	T651 <sup>E</sup>	80.00	160.00	380	...	325	...	...	3
6061	O	0.15	0.20	...	150	...	85	10	...
6061	O	0.20	0.25	...	150	...	85	12	...
6061	O	0.25	0.50	...	150	...	85	14	...
6061	O	0.50	3.20	...	150	...	85	16	...
6061	O	3.20	12.50	...	150	...	85	18	...
6061	O	12.50	25.00	...	150	...	...	...	16
6061	O	25.00	80.00	...	150	...	...	...	14
6061	T4	0.15	0.20	205	...	110	...	10	...
6061	T4	0.20	0.25	205	...	110	...	12	...

TABLE 5 Continued

Alloy	Temper	Specified Thickness, mm		Tensile Strength, MPa		Yield Strength (0.2 % offset), MPa		Elongation, <sup>C</sup> min, %	
		over	through	min	max	min	max	in 50 mm	in 5x Diameter
6061	T4	0.25	0.50	205	...	110	...	14	...
6061	T4	0.50	6.30	205	...	110	...	16	...
6061	T451 <sup>E</sup>	6.30	12.50	205	...	110	...	18	...
6061	T451 <sup>E</sup>	12.50	25.00	205	...	110	...	...	16
6061	T451 <sup>E</sup>	25.00	80.00	205	...	110	...	...	14
6061	T42 <sup>F</sup>	0.15	0.20	205	...	95	...	10	...
6061	T42 <sup>F</sup>	0.20	0.25	205	...	95	...	12	...
6061	T42 <sup>F</sup>	0.25	0.50	205	...	95	...	14	...
6061	T42 <sup>F</sup>	0.50	6.30	205	...	95	...	16	...
6061	T42 <sup>F</sup>	6.30	12.50	205	...	95	...	18	...
6061	T42 <sup>F</sup>	12.50	25.00	205	...	95	...	...	16
6061	T42 <sup>F</sup>	25.00	80.00	205	...	95	...	...	14
6061	T6, T62 <sup>F</sup>	0.15	0.20	290	...	240	...	4	...
6061	T6, T62 <sup>F</sup>	0.20	0.25	290	...	240	...	6	...
6061	T6, T62 <sup>F</sup>	0.25	0.50	290	...	240	...	8	...
6061	T6, T62 <sup>F</sup>	0.50	6.30	290	...	240	...	10	...
6061	T62 <sup>F</sup> T651 <sup>E</sup>	6.30	12.50	290	...	240	...	10	...
6061	T62 <sup>F</sup> T651 <sup>E</sup>	12.50	25.00	290	...	240	...	...	8
6061	T62 <sup>F</sup> T651 <sup>E</sup>	25.00	50.00	290	...	240	...	...	7
6061	T62 <sup>F</sup> T651 <sup>E</sup>	50.00	100.00	290	...	240	...	...	5
6061	T62 <sup>F</sup> T651 <sup>E</sup>	100.00	150.00 <sup>L</sup>	275	...	240	...	...	5
6061	F <sup>G</sup>	6.30	80.00	...	...	...	...	...	...
Alclad 6061	O	0.24	0.50	...	140	...	85	14	...
Alclad 6061	O	0.50	3.20	...	140	...	85	16	...
Alclad 6061	O	3.20	12.50	...	140	...	85	18	...
Alclad 6061	O	12.50	25.00	...	150 <sup>H</sup>	...	...	...	16
Alclad 6061	O	25.00	80.00	...	150 <sup>H</sup>	...	...	...	14
Alclad 6061	T4	0.24	0.50	185	...	95	...	14	...
Alclad 6061	T4	0.50	6.30	185	...	95	...	16	...
Alclad 6061	T451 <sup>E</sup>	6.30	12.50	185	...	95	...	18	...
Alclad 6061	T451 <sup>E</sup>	12.50	25.00	205 <sup>H</sup>	...	110 <sup>H</sup>	...	...	16
Alclad 6061	T451 <sup>E</sup>	25.00	80.00	205 <sup>H</sup>	...	110 <sup>H</sup>	...	...	14
Alclad 6061	T42 <sup>F</sup>	0.24	0.50	185	...	85	...	14	...
Alclad 6061	T42 <sup>F</sup>	0.50	6.30	185	...	85	...	16	...
Alclad 6061	T42 <sup>F</sup>	6.30	12.50	185	...	85	...	18	...
Alclad 6061	T42 <sup>F</sup>	12.50	25.00	205 <sup>H</sup>	...	95 <sup>H</sup>	...	...	16
Alclad 6061	T42 <sup>F</sup>	25.00	80.00	205 <sup>H</sup>	...	95 <sup>H</sup>	...	...	14
Alclad 6061	T6, T62 <sup>F</sup>	0.24	0.50	260	...	220	...	8	...
Alclad 6061	T6, T62 <sup>F</sup>	0.50	6.30	260	...	220	...	10	...
Alclad 6061	T62 <sup>F</sup> T651 <sup>E</sup>	6.30	12.50	260	...	220	...	10	...
Alclad 6061	T62 <sup>F</sup> T651 <sup>E</sup>	12.50	25.00	290 <sup>H</sup>	...	240 <sup>H</sup>	...	...	8
Alclad 6061	T62 <sup>F</sup> T651 <sup>E</sup>	25.00	50.00	290 <sup>H</sup>	...	240 <sup>H</sup>	...	...	7
Alclad 6061	T62 <sup>F</sup> T651 <sup>E</sup>	50.00	100.00	290 <sup>H</sup>	...	240 <sup>H</sup>	...	...	5
Alclad 6061	T62 <sup>F</sup> T651 <sup>E</sup>	100.00	120.00 <sup>L</sup>	275 <sup>H</sup>	...	240 <sup>H</sup>	...	...	5
Alclad 6061	F <sup>G</sup>	6.30	80.00	...	...	...	...	...	...
7075	O	0.39	12.50	...	275	...	145	10	...
7075	O	12.50	50.00	...	275	...	...	...	9
7075	T6, T62 <sup>F</sup>	0.19	0.32	510	...	435	...	5	...
7075	T6, T62 <sup>F</sup>	0.32	1.00	525	...	460	...	8	...
7075	T6, T62 <sup>F</sup>	1.00	3.20	540	...	470	...	9	...
7075	T6, T62 <sup>F</sup>	3.20	4.70	545	...	475	...	9	...
7075	T6, T62 <sup>F</sup>	4.70	6.30	550	...	475	...	9	...
7075	T62 <sup>F</sup> T651 <sup>E</sup>	6.30	12.50	540	...	460	...	9	...
7075	T62 <sup>F</sup> T651 <sup>E</sup>	12.50	25.00	540	...	470	...	...	6
7075	T62 <sup>F</sup> T651 <sup>E</sup>	25.00	50.00	530	...	460	...	...	5
7075	T62 <sup>F</sup> T651 <sup>E</sup>	50.00	60.00	525	...	440	...	...	4

TABLE 5 Continued

Alloy	Temper	Specified Thickness, mm		Tensile Strength, MPa		Yield Strength (0.2 % offset), MPa		Elongation, <sup>C</sup> min, %	
		over	through	min	max	min	max	in 50 mm	in 5x Diameter
7075	T62, <sup>F</sup> T651 <sup>E</sup>	60.00	80.00	495	...	420	...	...	4
7075	T62, <sup>F</sup> T651 <sup>E</sup>	80.00	90.00	490	...	400	...	...	4
7075	T62, <sup>F</sup> T651 <sup>E</sup>	90.00	100.00	460	...	370	...	...	2
7075	T73 sheet	1.00	6.30	460	...	385	...	8	...
7075	T7351 <sup>E</sup> plate	6.30	12.50	475	...	390	...	7	...
7075	T7351 <sup>E</sup> plate	12.50	25.00	475	...	390	...	...	6
7075	T7351 <sup>E</sup> plate	25.00	50.00	475	...	390	...	...	5
7075	T7351 <sup>E</sup> plate	50.00	60.00	455	...	360	...	...	5
7075	T7351 <sup>E</sup> plate	60.00	80.00	440	...	340	...	...	5
7075	T7351 <sup>E</sup> plate	80.00	90.00	435	...	340	...	...	5
7075	T7351 <sup>E</sup> plate	90.00	100.00	420	...	330	...	...	5
7075	T76 sheet	1.60	6.30	505	...	425	...	8	...
7075	T7651 <sup>E</sup> plate	6.30	12.50	495	...	420	...	8	...
7075	T7651 <sup>E</sup> plate	12.50	25.00	490	...	415	...	...	5
7075	F <sup>G</sup>	6.30	100.00	...	...	...	...	...	...
Alclad 7075	O	0.19	0.40	...	250	...	140	9	...
Alclad 7075	O	0.40	1.60	...	250	...	140	10	...
Alclad 7075	O	1.60	4.00	...	260	...	140	10	...
Alclad 7075	O	4.00	12.50	...	270	...	145	10	...
Alclad 7075	O	12.50	25.00	...	275 <sup>H</sup>	...	...	...	9
Alclad 7075	T6, T62 <sup>F</sup>	0.19	0.32	470	...	400	...	5	...
Alclad 7075	T6, T62 <sup>F</sup>	0.32	1.00	490	...	420	...	8	...
Alclad 7075	T6, T62 <sup>F</sup>	1.00	1.60	495	...	425	...	9	...
Alclad 7075	T6, T62 <sup>F</sup>	1.60	3.20	510	...	440	...	9	...
Alclad 7075	T6, T62 <sup>F</sup>	3.20	4.70	510	...	440	...	9	...
Alclad 7075	T6, T62 <sup>F</sup>	4.70	6.30	525	...	450	...	9	...
Alclad 7075	T62, <sup>F</sup> T651 <sup>E</sup>	6.30	12.50	515	...	445 <sup>H</sup>	...	9	...
Alclad 7075	T62, <sup>F</sup> T651 <sup>E</sup>	12.50	25.00	540 <sup>H</sup>	...	470 <sup>H</sup>	...	...	6
Alclad 7075	T62, <sup>F</sup> T651 <sup>E</sup>	25.00	50.00	530 <sup>H</sup>	...	460 <sup>H</sup>	...	...	5
Alclad 7075	T62, <sup>F</sup> T651 <sup>E</sup>	50.00	60.00	525 <sup>H</sup>	...	440 <sup>H</sup>	...	...	4
Alclad 7075	T62, <sup>F</sup> T651 <sup>E</sup>	60.00	80.00	495 <sup>H</sup>	...	420 <sup>H</sup>	...	...	4
Alclad 7075	T62, <sup>F</sup> T651 <sup>E</sup>	80.00	90.00	490 <sup>H</sup>	...	400 <sup>H</sup>	...	...	4
Alclad 7075	T62, <sup>F</sup> T651 <sup>E</sup>	90.00	100.00	460 <sup>H</sup>	...	370 <sup>H</sup>	...	...	2
Alclad 7075	T76 sheet	1.00	1.60	460	...	385	...	8	...
Alclad 7075	T76 sheet	1.60	4.70	470	...	395	...	8	...
Alclad 7075	T76 sheet	4.70	6.30	485	...	405	...	8	...
Alclad 7075	T7651 <sup>E</sup> plate	6.30	12.50	475	...	400	...	8	...
Alclad 7075	T7651 <sup>E</sup> plate	12.50	25.00	490 <sup>H</sup>	...	415 <sup>H</sup>	...	...	5
Alclad 7075	F <sup>G</sup>	6.30	100.00	...	...	...	...	...	...
Alclad 1-Side 7075	O	0.39	1.60	...	260	...	145	10	...
Alclad 1-Side 7075	O	1.60	4.00	...	270	...	145	10	...
Alclad 1-Side 7075	O	4.00	12.50	...	270	...	145	10	...
Alclad 1-Side 7075	O	12.50	25.00	...	275 <sup>H</sup>	...	...	...	9
Alclad 1-Side 7075	T6, T62 <sup>F</sup>	0.19	0.32	490	...	415	...	5	...
Alclad 1-Side 7075	T6, T62 <sup>F</sup>	0.32	1.00	510	...	440	...	8	...
Alclad 1-Side 7075	T6, T62 <sup>F</sup>	1.00	1.60	515	...	450	...	9	...
Alclad 1-Side 7075	T6, T62 <sup>F</sup>	1.60	3.20	525	...	455	...	9	...
Alclad 1-Side 7075	T6, T62 <sup>F</sup>	3.20	4.70	530	...	460	...	9	...
Alclad 1-Side 7075	T6, T62 <sup>F</sup>	4.70	6.30	540	...	460	...	9	...
Alclad 1-Side 7075	T62, <sup>F</sup> T651 <sup>E</sup>	6.30	12.50	525	...	455	...	9	...

TABLE 5 Continued

Alloy	Temper	Specified Thickness, mm		Tensile Strength, MPa		Yield Strength (0.2 % offset), MPa		Elongation, <sup>C</sup> min, %	
		over	through	min	max	min	max	in 50 mm	in 5x Diameter
Alclad 1-Side 7075	T62, <sup>F</sup> T651 <sup>E</sup>	12.50	25.00	540 <sup>H</sup>	...	470 <sup>H</sup>	...	...	6
	T62, <sup>F</sup> T651 <sup>E</sup>	25.00	50.00	530 <sup>H</sup>	...	460 <sup>H</sup>	...	...	5

<sup>A</sup> To determine conformance to this specification, each value for tensile strength shall be rounded to the nearest 1 MPa and each value for elongation to the nearest 0.5 %, both in accordance with the Rounding Method of Practice E29.

<sup>B</sup> The basis for establishment of mechanical property limits is shown in Annex A1.

<sup>C</sup> Elongations in 50 mm apply for thicknesses up through 12.50 mm and in 5x diameter for thicknesses over 12.50 mm.

<sup>D</sup> Coiled sheet.

<sup>E</sup> For stress-relieved tempers (T351, T451, T651, T7351, T7651, and T851), characteristics and properties other than those specified may differ somewhat from the corresponding characteristics and properties of material in the basic temper.

<sup>F</sup> Material in the T42, T62, and T72 tempers is not available from the material producer.

<sup>G</sup> Test for tensile properties in the F temper are not required.

<sup>H</sup> The tension test specimen from plate over 12.50 mm in thickness is machined from the core and does not include the cladding.

<sup>I</sup> The T72 temper is applicable only to Alloys 2024 and Alclad 2024 sheet solution heat treated and artificially overaged by the user to develop increased resistance to stress-corrosion cracking.

<sup>J</sup> Short transverse tensile properties are not applicable to material less than 40 mm in thickness.

<sup>K</sup> Use of Alloys 2219 and Alclad 2219 in the T31, T351, and T37 tempers for finished products is not recommended.

<sup>L</sup> The properties for this thickness apply only to the T651 temper.

<sup>M</sup> Mechanical property requirements for product outside the gauge range covered by Table 5 shall be agreed upon between purchaser and producer.

11.5 Mill-produced material in the following alloys and tempers and T42 temper material shall, after proper precipitation heat treatment, be capable of attaining the properties specified in Table 4 or Table 5 for the aged tempers listed below.

Alloy and Temper	Temper after Aging
2014 and Alclad 2014-T3, T4, T42, T451	T6, T6, T62, T651, respectively
2024, Alclad 2024, 1 ½ % Alclad 2024, Alclad 1-Side 2024 and 1½ % Alclad one side 2024-T3, T351, T361, T42	T81, T851, T861, T62, or T72, respectively
2219 and Alclad 2219-T31, T351, T37	T81, T851, T87, respectively
6061 and Alclad 6061-T4, T451, T42	T6, T651, T62, respectively

## 12. Bend Properties

12.1 *Limits*—Sheet and plate shall be capable of being bent cold through an angle of 180° around a pin having a diameter

equal to  $N$  times the thickness of the sheet or plate without cracking, the value of  $N$  being as prescribed in Table 2, Table 3, Table 4, and Table 5 for the different alloys, tempers, and thicknesses. The test need not be conducted unless specified on the purchase order.

12.2 *Test Specimens*—When bend tests are made, the specimens for sheet shall be the full thickness of the material, approximately ¾ in. in width, and when practical, at least 6 in. in length. Such specimens may be taken in any direction and their edges may be rounded to a radius of approximately ¼ in. if desired. For sheet less than ¾ in. in width, the specimens should be the full width of the material.

12.3 *Test Methods*—The bend tests shall be made in accordance with Test Method E290 except as stated otherwise in 12.2.

**13. Stress-corrosion Resistance**

13.1 When specified on the purchase order or contract, alloys 2124-T851, 2219-T851, and 2219-T87 plate shall be subjected to the test specified in 13.3 and shall exhibit no evidence of stress-corrosion cracking. One sample shall be taken from each parent plate in each lot and a minimum of three adjacent replicate specimens from this sample shall be tested. The producer shall maintain records of all lot acceptance test results and make them available for examination at the producer’s facility.

13.2 Alloy 7075 in the T73-type and T76-type tempers, and Alclad 7075 in the T76-type tempers, shall be capable of exhibiting no evidence of stress-corrosion cracking when subjected to the test specified in 13.3.

13.2.1 For lot-acceptance purposes, resistance to stress-corrosion cracking for each lot of material shall be established by testing the previously selected tension-test samples to the criteria shown in Table 6.

13.2.2 For surveillance purposes, each month the producer shall perform at least one test for stress-corrosion resistance in accordance with 13.3 on each applicable alloy-temper for each thickness range 0.750 in. [20.00 mm] and over listed in Table 4 and Table 5, produced that month. Each sample shall be taken from material considered acceptable in accordance with lot-acceptance criteria of Table 6. A minimum of three adjacent replicate specimens shall be taken from each sample and tested. The producer shall maintain records of all lots so tested and make them available for examination at the producer’s facility.

13.3 The stress-corrosion cracking test shall be performed on plate 0.750 in. [20.00 mm] and over in thickness as follows:

13.3.1 Specimens shall be stressed in tension in the short transverse direction with respect to grain flow and held at constant strain. For alloy 2124-T851, the stress levels shall be 50 % of the specified minimum long transverse yield strength. For alloy 2219-T851 and T87, the stress levels shall be 75 % of the specified minimum long transverse yield strength. For alloy 7075 in the T73-type tempers, the stress level shall be 75 % of the specified minimum yield strength, and for alloy 7075 and Alclad 7075 in the T76-type, it shall be 25 ksi [170 MPa].

13.3.2 The stress-corrosion test shall be made in accordance with Test Method G47.

13.3.3 There shall be no visual evidence of stress-corrosion cracking in any specimen, except that the retest provisions of 19.2 shall apply.

**14. Exfoliation-corrosion Resistance**

14.1 Alloys 7075 and Alclad 7075, in the T76-type tempers, shall be capable of exhibiting no evidence of exfoliation corrosion equivalent to or in excess of that illustrated by Photo EB in Fig. 2 of Test Method G34 when subjected to the test in 14.2.

14.1.1 For lot-acceptance purposes, resistance to exfoliation corrosion for each lot of material in the alloys and tempers listed in 14.1 shall be established by testing the previously selected tension-test samples to the criteria shown in Table 6.

14.1.2 For surveillance purposes, each month the producer shall perform at least one test for exfoliation-corrosion resistance on each applicable alloy-temper for each thickness range listed in Table 4 and Table 5, produced that month. The samples for test shall be selected at random from material considered acceptable in accordance with the lot-acceptance

**TABLE 6 Lot Acceptance Criteria for Resistance to Stress Corrosion and Exfoliation Corrosion**

NOTE 1—For alclad products, the cladding shall be removed and the electrical conductivity determined on the core alloy.

Alloy and Temper	Lot Acceptance Criteria		Lot Acceptance Status
	Electrical Conductivity, <sup>A</sup> % IACS	Level of Mechanical Properties	
7075–T73 and T7351	40.0 or greater	in accordance with specified requirements	acceptable
	38.0 through 39.9	in accordance with specified requirements but yield strength does not exceed minimum by more than 11.9 ksi	acceptable
	38.0 through 39.9	in accordance with specified requirements but yield strength exceeds minimum by 12.0 ksi or more	unacceptable <sup>B</sup>
	less than 38.0	any level	unacceptable <sup>B</sup>
7075–T76 and T7651 Alclad 7075–T76 and T7651	38.0 or greater	in accordance with specified requirements	acceptable
	36.0 through 37.9	in accordance with specified requirements	suspect <sup>C</sup>
	less than 36.0	any level	unacceptable <sup>B</sup>

<sup>A</sup> The electrical conductivity shall be determined in accordance with Practice E1004 in the locations specified below.

<sup>B</sup> When material is found to be unacceptable, it shall be reprocessed (additional precipitation heat treatment or re-solution heat treatment, stress relieving and precipitation heat treatment, when applicable).

<sup>C</sup> When material in these tempers is found to be suspect it is either tested for exfoliation corrosion resistance in accordance with Test Method G34 or it is reprocessed (additional precipitation heat treatment or resolution heat treatment and precipitation heat treatment). Favorable exfoliation corrosion test results must never be used as an acceptance criteria for stress corrosion resistance.

Alloy-Temper	Thickness, in.	Location
7075–T73 and T7351	all	surface of tension-test sample
	up through 0.100	surface of tension-test sample
7075–T76 and T7651	0.101 and over	sub-surface after removal of approximately 10 % of the thickness

For alclad products, the cladding shall be removed and the electrical conductivity determined on the core alloy.

criteria of Table 6. The producer shall maintain records of all surveillance test results and make them available for examination.

14.2 The test for exfoliation-corrosion resistance shall be made in accordance with Test Method G34 and the following:

14.2.1 The specimens shall be a minimum of 2 by 4 in. [50 by 100 mm] with the 4-in. [100 mm] dimension in a plane parallel to the direction of final rolling. They shall be full-section thickness specimens of the material except that for material 0.101 in. [2.5 mm] or more in thickness, 10 % of the thickness shall be removed by machining one surface. The cladding of alclad sheet of any thickness shall be removed by machining the test surface; the cladding on the back side (nontest surface) of the specimen for any thickness of alclad material shall also either be removed or masked off. For machined specimens, the machined surface shall be evaluated by exposure to the test solution.

## 15. Cladding

15.1 Preparatory to rolling alclad sheet and plate to the specified thickness, the aluminum or aluminum-alloy plates

which are bonded to the alloy ingot or slab shall be of the composition shown in Table 1 and shall each have a thickness not less than that shown in Table 7 and Table 8 for the alloy specified.

15.2 When the thickness of the cladding is to be determined on finished material, not less than one transverse sample approximately  $\frac{3}{4}$  in. in length shall be taken from each edge and from the center width of the material. Samples shall be mounted to expose a transverse cross section and shall be polished for examination with a metallurgical microscope. Using 100× magnification, the maximum and minimum cladding thickness on each surface shall be measured in each of five fields approximately 0.1 in. apart for each sample. The average of the ten values (five minima plus five maxima) on each sample surface is the average cladding thickness and shall meet the minimum average and, when applicable, the maximum average specified in Table 7 and Table 8.

## 16. Dimensional Tolerances

16.1 *Thickness*—The thickness of flat sheet, coiled sheet, and plate shall not vary from that specified by more than the

TABLE 7 Components of Clad Products, Inch-Pound Units

Alloy	Component Alloys <sup>A</sup>		Total Composite Thickness of Finished Sheet and Plate, in.	Sides Clad	Cladding Thickness per Side, percent of Composite Thickness		
	Core	Cladding			Nominal	Average <sup>B</sup>	
						min	max
Alclad 2014	2014	6003	up through 0.024	both	10	8	...
			0.025–0.039	both	7.5	6	...
			0.040–0.099	both	5	4	...
			0.100 and over	both	2.5	2	3 <sup>C</sup>
Alclad 2024	2024	1230	up through 0.062	both	5	4	...
			0.063 and over	both	2.5	2	3 <sup>C</sup>
1½ % Alclad 2024	2024	1230	0.188 and over	both	1.5	1.2	3 <sup>D</sup>
Alclad one-side 2024	2024	1230	up through 0.062	one	5	4	...
			0.063 and over	one	2.5	2	3 <sup>C</sup>
1½ % Alclad one-side 2024	2024	1230	0.188 and over	one	1.5	1.2	3 <sup>D</sup>
Alclad 2219	2219	7072	up through 0.039	both	10	8	...
			0.040–0.099	both	5	4	...
			0.100 and over	both	2.5	2	3 <sup>C</sup>
Alclad 3003	3003	7072	all	both	5	4	6 <sup>C</sup>
Alclad 3004	3004	7072	all	both	5	4	6 <sup>C</sup>
Alclad 6061	6061	7072	all	both	5	4	6 <sup>C</sup>
Alclad 7075	7075	7072	up through 0.062	both	4	3.2	...
			0.063–0.187	both	2.5	2	...
			0.188 and over	both	1.5	1.2	3 <sup>D</sup>
Alclad one-side 7075	7075	7072	up through 0.062	one	4	3.2	...
			0.063–0.187	one	2.5	2	...
			0.188 and over	one	1.5	1.2	3 <sup>D</sup>

<sup>A</sup> Cladding composition is applicable only to the aluminum alloy bonded to the alloy ingot or slab preparatory to rolling to the specified composite product. The composition of the cladding may be altered subsequently by diffusion between the core and cladding due to thermal treatment.

<sup>B</sup> Average thickness per side as determined by averaging cladding thickness measurements when determined in accordance with the procedure specified in 15.2.

<sup>C</sup> Applicable for thicknesses of 0.500 in. and greater.

<sup>D</sup> For thicknesses of 0.500 in. and over with 1.5 % of nominal cladding thickness, the average maximum thickness of cladding per side after rolling to the specified thickness of plate shall be 3 % of the thickness of the plate as determined by averaging cladding thickness measurements taken at a magnification of 100 diameters on the cross section of a transverse sample polished and etched for examination with a metallurgical microscope.

TABLE 8 Components of Clad Products, SI Units

Alloy	Component Alloys <sup>A</sup>		Specified Total Composite Thickness of Finished Sheet and Plate, mm		Sides Clad	Cladding Thickness per Side, percent of Composite Thickness		
			Over	Through		Nominal	Average <sup>B</sup>	
	Core	Cladding					min	max
Alclad 2014	2014	6003	...	0.63	both	10	8	...
			0.63	1.00	both	7.5	6	...
			1.00	2.50	both	5	4	...
			2.50	...	both	2.5	2	3 <sup>C</sup>
Alclad 2024	2024	1230	...	1.60	both	5	4	...
			1.60	...	both	2.5	2	3 <sup>D</sup>
1½ % Alclad 2024	2024	1230	4.00	...	both	1.5	1.2	3 <sup>D</sup>
Alclad 1-Side 2024	2024	1230	...	1.60	one	5	4	...
			1.60	...	one	2.5	2	3 <sup>C</sup>
1½ % Alclad 1-Side 2024	2024	1230	4.00	...	one	1.5	1.2	3 <sup>D</sup>
Alclad 2219	2219	7072	...	1.00	both	10	8	...
			1.00	2.50	both	5	4	...
			2.50	...	both	2.5	2	3 <sup>C</sup>
Alclad 3003	3003	7072	all		both	5	4	6 <sup>C</sup>
Alclad 3004	3004	7072	all		both	5	4	6 <sup>C</sup>
Alclad 6061	6061	7072	all		both	5	4	6 <sup>C</sup>
Alclad 7075	7075	7072	...	1.60	both	4	3.2	...
			1.60	4.00	both	2.5	2	...
			4.00	...	both	1.5	1.2	3 <sup>D</sup>
Alclad 1-Side 7075	7075	7072	...	1.60	one	4	3.2	...
			1.60	4.00	one	2.5	2	...
			4.00	...	one	1.5	1.2	3 <sup>D</sup>

<sup>A</sup> Cladding composition is applicable only to the aluminum alloy bonded to the alloy ingot or slab preparatory to rolling to the specified composite product. The composition of the cladding may be altered subsequently by diffusion between the core and cladding due to thermal treatment.

<sup>B</sup> Average thickness per side as determined by averaging cladding thickness measurements when determined in accordance with the procedure specified in 15.2.

<sup>C</sup> Applicable for thicknesses over 12.50 mm.

<sup>D</sup> For thickness over 12.50 mm with 1.5 % of nominal cladding thickness, the average maximum thickness of cladding per side after rolling to the specified thickness of plate shall be 3 % of the thickness of the plate as determined by averaging cladding thickness measurements taken at a magnification of 100 diameters on the cross section of a transverse sample polished and etched for examination with a metallurgical microscope.

respective permissible variations prescribed in Tables 7.7a, 7.7b, 7.26, 7.31, and 8.2 of ANSI H35.2 [H35.2M]. Permissible variations in thickness of plate specified in thicknesses exceeding 6 in. shall be the subject of agreement between the purchaser and the producer or the supplier at the time the order is placed.

16.2 *Length, Width, Lateral Bow, Squareness, and Flatness*—Coiled sheet shall not vary in width or in lateral bow from that specified by more than the permissible variations prescribed in Tables 7.11 and 7.12, respectively, of ANSI H35.2 [H35.2M]. Flat sheet and plate shall not vary in width, length, lateral bow, squareness, or flatness by more than the permissible variations prescribed in the following tables of ANSI H35.2 [H35.2M] except that where the tolerances for sizes ordered are not covered by this specification, the permissible variations shall be the subject of agreement between the purchaser and the producer or the supplier at the time the order is placed:

Table No.	Title
7.8	Width, Sheared Flat Sheet and Plate
7.9	Length, Sheared Flat Sheet and Plate
7.10	Width and Length, Sawed Flat Sheet and Plate
7.13	Lateral Bow, Flat Sheet and Plate
7.14	Squareness, Flat Sheet and Plate
7.17	Flatness, Flat Sheet
7.18	Flatness, Sawed or Sheared Plate

16.3 Dimensional tolerances for sizes not covered in ANSI H35.2 [H35.2M] shall be as agreed upon between the producer and purchaser and shall be specified in the contract or purchase order.

16.4 *Sampling for Inspection*—Examination for dimensional conformance shall be made to ensure conformance to the tolerance specified.

**17. Internal Quality**

17.1 When specified by the purchaser at the time of placing the order, plate 0.500 to 4.500 in. [12.50 through 115.00 mm] in thickness and up to 2000 lb [1000 kg] in maximum weight

in alloys 2014, 2024, 2124, 2219, and 7075, both bare and Alclad where applicable, shall be tested in accordance with Practice B594 to the discontinuity acceptance limits of Table 9 and Table 10.

17.2 When specified by the purchaser at the time of placing the order, plate 0.500 in. [12.50 mm] in thickness and greater for ASME pressure vessel applications in alloys 1060, 1100, 3003, Alclad 3003, 3004, Alclad 3004, 5052, 5083, 5086, 5154, 5254, 5454, 5456, 6061, and Alclad 6061 shall be tested in accordance with Test Method B548. In such cases, the material will be subject to rejection if the following limits are exceeded unless it is determined by the purchaser that the area of the plate containing significant discontinuities will be removed during the subsequent fabrication process or that the plate may be repaired by welding:

17.2.1 If the longest dimension of the marked area representing a discontinuity causing a complete loss of back reflection (95 % or greater) exceeds 1.0 in [25 mm].

17.2.2 If the length of the marked area representing a discontinuity causing an isolated ultrasonic indication without a complete loss of back reflection (95 % or greater) exceeds 3.0 in [75 mm].

17.2.3 If each of two marked areas representing two adjacent discontinuities causing isolated ultrasonic indications without a complete loss of back reflection (95 % or greater) is longer than 1.0 in. [25 mm], and if they are located within 3.0 in. [75 mm] of each other.

## 18. Source Inspection

18.1 If the purchaser desires that their representative inspect or witness the inspection and testing of the material prior to shipment, such agreement shall be made by the purchaser and producer as part of the purchase contract.

18.2 When such inspection or witness of inspection and testing is agreed upon, the producer shall afford the purchaser's representative all reasonable facilities to satisfy him that the material meets the requirements of this specification. Inspection and tests shall be conducted so there is no unnecessary interference with the producer's operations.

## 19. Retest and Rejection

19.1 If any material fails to conform to all of the applicable requirements of this specification, the inspection lot shall be rejected.

19.2 When there is evidence that a failed specimen was not representative of the inspection lot and when no other sampling plan is provided or approved by the purchaser through the contract or purchase order, at least two additional specimens shall be selected to replace each test specimen that failed. All specimens so selected for retest shall meet the requirements of the specification or the lot shall be subject to rejection.

19.3 Material which is determined to be non-conforming subsequent to inspection may be rejected.

19.4 If material is rejected by the purchaser, the producer or supplier is responsible only for replacement of material to the purchaser. As much as possible of the rejected material shall be returned to the producer or supplier by the purchaser.

## 20. Identification Marking of Product

20.1 All sheet and plate shall be marked in accordance with Practice B666/B666M, unless otherwise specified.

20.2 The requirements specified in 20.1 are minimum; marking systems that involve added information, larger characters, and greater frequencies are acceptable under this specification.

## 21. Packaging and Package Marking

21.1 The material shall be packaged to provide adequate protection during normal handling and transportation and each package shall contain only one size, alloy, and temper of material unless otherwise agreed. The type of packaging and gross weight of containers shall, unless otherwise agreed, be at the producer's or supplier's discretion, provided that they are such as to ensure acceptance by common or other carriers for safe transportation at the lowest rate to the delivery point.

21.2 Each shipping container shall be marked with the purchase order number, material size, specification number, alloy and temper, gross and net weights, and the producer's name or trademark.

21.3 When specified in the contract or purchase order, material shall be preserved, packaged, and packed in accordance with the requirements of Practices B660. The applicable levels shall be as specified in the contract or order.

## 22. Certification

22.1 The producer or supplier shall, on request, furnish to the purchaser a certificate stating that each lot has been

TABLE 9 Ultrasonic Discontinuity Limits for Plate, Inch-Pound Units<sup>A</sup>

Alloy	Thickness, in.	Maximum Weight Per Piece, lb <sup>B</sup>	Discontinuity Class <sup>C</sup>
2014 <sup>D</sup> 2024 <sup>D</sup>	0.500–1.499	2000	B
2124 2219 <sup>D</sup> 7075 <sup>D</sup>	1.500–3.000	2000	A
	3.001–6.000	2000	B

<sup>A</sup> Discontinuities in excess of those listed in this table shall be allowed if it is established that they will be removed by machining or that they are in noncritical areas.

<sup>B</sup> The maximum weight is either the ordered weight of a plate of rectangular shape or the planned weight of a rectangular plate prior to removing metal to produce a part or plate shape to a drawing.

<sup>C</sup> The discontinuity class limits are defined in Section 11 of Practice B594.

<sup>D</sup> Also applies for alclad plate.

**TABLE 10 Ultrasonic Discontinuity Limits for Plate, SI Units<sup>A</sup>**

Alloy	Thickness, mm		Maximum Mass per Piece, kg <sup>B</sup>	Discontinuity Class <sup>C</sup>
	over	through		
2014 <sup>D</sup> 2024 <sup>D</sup>	12.50	38.00	1,000	B
2124 2219 <sup>D</sup>	38.00	80.00	1,000	A
7075 <sup>D</sup>	80.00	115.00	1,000	B

<sup>A</sup> Discontinuities in excess of those listed in this table shall be allowed if it is established that they will be removed by machining or that they are in non-critical areas.

<sup>B</sup> The maximum mass is either the ordered mass of a plate of rectangular shape or the planned mass of a rectangular plate prior to removing metal to produce a part or plate shape to a drawing.

<sup>C</sup> The discontinuity class limits are defined in Section 11 of Practice B594.

<sup>D</sup> Also applies for alclad plate.

sampled, tested, and inspected in accordance with this specification, and has met the requirements.

**23. Keywords**

23.1 aluminum alloy; aluminum-alloy plate; aluminum-alloy sheet

**ANNEXES**

**(Mandatory Information)**

**A1. BASIS FOR INCLUSION OF PROPERTY LIMITS**

A1.1 Mechanical property limits are established in accord with Section 6, Standards Section, of the most current edition of the Aluminum Standards and Data and the latest edition of the Aluminum Association publication “Tempers for Aluminum and Aluminum Alloy Products (Yellow and Tan Sheets).”

A1.2 Limits are based on a statistical evaluation of the data indicating that at least 99 % of the population obtained from all standard material meets the limit with 95 % confidence. For the products described, mechanical property limits are based on the statistical analyses of at least 100 tests from at least five cast lots of standard production material with no more than ten observations from a given heat treat or inspection lot. Mechanical properties limits for press solution heat treated products have specific additional requirements which are provided in the “Tempers for Aluminum and Aluminum Alloy Products.”

A1.3 Limits denoted as “Tentative” by the Aluminum Association may be included. Requirements for tentative property registrations are defined in the latest edition of the Aluminum Association publication “Tempers for Aluminum and Aluminum Alloy Products.” Tentative property limits are established at levels at which at least 99 % of the data conform at a confidence level of 95 %. Tentative property limits, which are subject to revision, shall be based on a statistical analysis of at least 30 tests from at least three cast lots of standard production material with no more than ten observations from a given heat treat or inspection lot. Where tentative property limits are listed, they shall be shown in italics and footnoted as Tentative in the standard.

A1.4 All tests are performed in accordance with the appropriate ASTM test methods.

## A2. ACCEPTANCE CRITERIA FOR INCLUSION OF NEW ALUMINUM AND ALUMINUM ALLOYS IN SPECIFICATION B209/B209M

A2.1 Prior to acceptance for inclusion in this specification, the composition of wrought or cast aluminum or aluminum alloy shall be registered in accordance with ANSI H35.1/H35.1M. The Aluminum Association<sup>5</sup> holds the Secretariat of ANSI H35 Committee and administers the criteria and procedures for registration.

A2.2 If it is documented that the Aluminum Association could not or would not register a given composition, an alternative procedure and the criteria for acceptance shall be as follows:

A2.2.1 The designation submitted for inclusion does not utilize the same designation system as described in ANSI H35.1/H35.1M. A designation not in conflict with other designation systems or a trade name is acceptable.

A2.2.2 The aluminum or aluminum alloy has been offered for sale in commercial quantities within the prior twelve months to at least three identifiable users.

A2.2.3 The complete chemical composition limits are submitted.

A2.2.4 The composition is, in the judgment of the responsible subcommittee, significantly different from that of any other aluminum or aluminum alloy already in the specification.

A2.2.5 For codification purposes, an alloying element is any element intentionally added for any purpose other than grain

refinement and for which minimum and maximum limits are specified. Unalloyed aluminum contains a minimum of 99.00 % aluminum.

A2.2.6 Standard limits for alloying elements and impurities are expressed to the following decimal places:

Less than 0.001 %	0.000X
0.001 to but less than 0.01 %	0.00X
0.01 to but less than 0.10 %	
Unalloyed aluminum made by a refining process	0.0XX
Alloys and unalloyed aluminum not made by a refining process	0.0X
0.10 through 0.55 %	0.XX
(It is customary to express limits of 0.30 through 0.55 % as 0.X0 or 0.X5.)	
Over 0.55 %	0.X, X.X, and so forth
(except that combined Si + Fe limits for 99.00 % minimum aluminum must be expressed as 0.XX or 1.XX)	

A2.2.7 Standard limits for alloying elements and impurities are expressed in the following sequence: Silicon; Iron; Copper; Manganese; Magnesium; Chromium; Nickel; Zinc; Titanium; (Note A2.1); Other Elements, Each; Other Elements, Total; Aluminum (Note A2.2).

NOTE A2.1—Additional specified elements having limits are inserted in alphabetical order of their chemical symbols between Titanium and Other Elements, Each, or are specified in footnotes.

NOTE A2.2—Aluminum is specified as *minimum* for unalloyed aluminum and as a *remainder* for aluminum alloys.

### SUMMARY OF CHANGES

Committee B07 has identified the location of selected changes to this standard since the last issue (B209/B209M – 21) that may impact the use of this standard. (Approved Dec. 1, 2021.)

- (1) Corrected Footnote M of Table 1 to reference the correct table.
- (2) Corrected subsection 8.1 to reference Table 4 and Table 5 instead of Table 3.
- (3) Added 5083-H111 minimum properties.

Committee B07 has identified the location of selected changes to this standard since the last issue (B209 – 14) that may impact the use of this standard. (Approved May 1, 2021.)

- (1) Merged B209M into B209.
- (2) Updated Aluminum Association address.
- (3) Added footnotes to Tables 2-5: Mechanical property requirements for product outside the gauge range covered by Table X shall be agreed upon between purchaser and producer.

ASTM International takes no position respecting the validity of any patent rights asserted in connection with any item mentioned in this standard. Users of this standard are expressly advised that determination of the validity of any such patent rights, and the risk of infringement of such rights, are entirely their own responsibility.

This standard is subject to revision at any time by the responsible technical committee and must be reviewed every five years and if not revised, either reapproved or withdrawn. Your comments are invited either for revision of this standard or for additional standards and should be addressed to ASTM International Headquarters. Your comments will receive careful consideration at a meeting of the responsible technical committee, which you may attend. If you feel that your comments have not received a fair hearing you should make your views known to the ASTM Committee on Standards, at the address shown below.

This standard is copyrighted by ASTM International, 100 Barr Harbor Drive, PO Box C700, West Conshohocken, PA 19428-2959, United States. Individual reprints (single or multiple copies) of this standard may be obtained by contacting ASTM at the above address or at 610-832-9585 (phone), 610-832-9555 (fax), or [service@astm.org](mailto:service@astm.org) (e-mail); or through the ASTM website ([www.astm.org](http://www.astm.org)). Permission rights to photocopy the standard may also be secured from the Copyright Clearance Center, 222 Rosewood Drive, Danvers, MA 01923, Tel: (978) 646-2600; <http://www.copyright.com/>

ASMENORMDOC.COM : Click to view the full PDF of ASME BPVC.II.B (ASME BPVC Section II part B) 2025

# SPECIFICATION FOR ALUMINUM AND ALUMINUM-ALLOY DRAWN SEAMLESS TUBES



**SB-210**

(Identical with ASTM Specification B210-12 except that certification, test reports, and testing for leaks have been made mandatory.)

ASMENORMDOC.COM : Click to view the full PDF of ASME BPVC.II.B (ASME BPVC Section II part B) 2025

# Specification for Aluminum and Aluminum-Alloy Drawn Seamless Tubes

## 1. Scope

1.1 This specification covers aluminum and aluminum-alloy drawn seamless tubes in straight lengths and coils for general purpose and pressure applications in alloys (Note 2), tempers, and thicknesses shown in Table 2. Coiled tubes are generally available only as round tubes with a wall thickness not exceeding 0.083 in. and only in nonheat-treatable alloys.

1.2 Alloy and temper designations are in accordance with ANSI H35.1/H35.1(M). The equivalent Unified Numbering System alloy designations are those of Table 1 preceded by A9, for example, A91100 for aluminum designation 1100 in accordance with Practice E527.

NOTE 1—See Specification B483/B483M for aluminum-alloy drawn tubes for general purpose applications; Specification B234 for aluminum-alloy drawn seamless tubes for condensers and heat exchangers; and Specification B241/B241M for aluminum-alloy seamless pipe and seamless extruded tube.

NOTE 2—Throughout this specification, use of the term *alloy* in the general sense includes aluminum as well as aluminum alloy.

1.3 A complete metric companion to Specification B210 has been developed—Specification B210M; therefore, no metric equivalents are presented in this specification.

1.4 For acceptance criteria for inclusion of new aluminum and aluminum alloys in this specification, see Annex A2.

1.5 *This standard does not purport to address all of the safety concerns, if any, associated with its use. It is the responsibility of the user of this standard to establish appropriate safety and health practices and determine the applicability of regulatory limitations prior to use.*

## 2. Referenced Documents

2.1 The following documents of the issue in effect on date of material purchase form a part of this specification to the extent referenced herein:

### 2.2 ASTM Standards:

- B234 Specification for Aluminum and Aluminum-Alloy Drawn Seamless Tubes for Condensers and Heat Exchangers
- B241/B241M Specification for Aluminum and Aluminum-Alloy Seamless Pipe and Seamless Extruded Tube
- B483/B483M Specification for Aluminum and Aluminum-Alloy Drawn Tube and Pipe for General Purpose Applications (Withdrawn 2012)
- B557 Test Methods for Tension Testing Wrought and Cast Aluminum- and Magnesium-Alloy Products
- B660 Practices for Packaging/Packing of Aluminum and Magnesium Products
- B666/B666M Practice for Identification Marking of Aluminum and Magnesium Products
- B807/B807M Practice for Extrusion Press Solution Heat Treatment for Aluminum Alloys
- B881 Terminology Relating to Aluminum- and Magnesium-Alloy Products
- B918/B918M Practice for Heat Treatment of Wrought Aluminum Alloys
- E29 Practice for Using Significant Digits in Test Data to Determine Conformance with Specifications
- E34 Test Methods for Chemical Analysis of Aluminum and Aluminum-Base Alloys
- E215 Practice for Standardizing Equipment for Electromagnetic Testing of Seamless Aluminum-Alloy Tube
- E527 Practice for Numbering Metals and Alloys in the Unified Numbering System (UNS)
- E607 Test Method for Atomic Emission Spectrometric Analysis Aluminum Alloys by the Point to Plane Technique Nitrogen Atmosphere (Withdrawn 2011)
- E716 Practices for Sampling and Sample Preparation of Aluminum and Aluminum Alloys for Determination of Chemical Composition by Spectrochemical Analysis
- E1004 Test Method for Determining Electrical Conductivity Using the Electromagnetic (Eddy-Current) Method

TABLE 1 Chemical Composition Limits<sup>A,B,C,D</sup>

Alloy	Silicon	Iron	Copper	Manganese	Magnesium	Chromium	Zinc	Titanium	Bismuth	Lead	Other Elements <sup>E</sup>		Aluminum, min
											Each	Total <sup>F</sup>	
1060	0.25	0.35	0.05	0.03	0.03	...	0.05	0.03	...	...	0.03 <sup>G</sup>	...	99.60 min <sup>H</sup>
1100	0.95 Si + Fe	...	0.05–0.20	0.05	...	...	0.10	...	...	...	0.05	0.15	99.00 min <sup>H</sup>
2011	0.40	0.7	5.0–6.0	...	...	...	0.30	...	0.20–0.6	0.20–0.6	0.05	0.15	remainder
2014	0.50–1.2	0.7	3.9–5.0	0.40–1.2	0.20–0.8	0.10	0.25	0.15	...	...	0.05	0.15	remainder
2024	0.50	0.50	3.8–4.9	0.30–0.9	1.2–1.8	0.10	0.25	0.15	...	...	0.05	0.15	remainder
3003	0.6	0.7	0.05–0.20	1.0–1.5	...	...	0.10	...	...	...	0.05	0.15	remainder
Alclad 3003 <sup>I</sup>	...	...	...	...	...	...	...	...	...	...	...	...	...
3102	0.40	0.7	0.10	0.05–0.40	...	...	0.30	0.10	...	...	0.05	0.15	remainder
Alclad 3102 <sup>J</sup>	...	...	...	...	...	...	...	...	...	...	...	...	...
5005	0.30	0.7	0.20	0.20	0.50–1.1	0.10	0.25	...	...	...	0.05	0.15	remainder
5050	0.40	0.7	0.20	0.10	1.1–1.8	0.10	0.25	...	...	...	0.05	0.15	remainder
5052	0.25	0.40	0.10	0.10	2.2–2.8	0.15–0.35	0.10	...	...	...	0.05	0.15	remainder
5083	0.40	0.40	0.10	0.40–1.0	4.0–4.9	0.05–0.25	0.25	0.15	...	...	0.05	0.15	remainder
5086	0.40	0.50	0.10	0.20–0.7	3.5–4.5	0.05–0.25	0.25	0.15	...	...	0.05	0.15	remainder
5154	0.25	0.40	0.10	0.10	3.1–3.9	0.15–0.35	0.20	0.20	...	...	0.05	0.15	remainder
5456	0.25	0.40	0.10	0.50–1.0	4.7–5.5	0.05–0.20	0.25	0.20	...	...	0.05	0.15	remainder
6061	0.40–0.8	0.7	0.15–0.40	0.15	0.8–1.2	0.04–0.35	0.25	0.15	...	...	0.05	0.15	remainder
6063	0.20–0.6	0.35	0.10	0.10	0.45–0.9	0.10	0.10	0.10	...	...	0.05	0.15	remainder
6262	0.40–0.8	0.7	0.15–0.40	0.15	0.8–1.2	0.04–0.14	0.25	0.15	0.40–0.7	0.40–0.7	0.05	0.15	remainder
7072 cladding	0.7 Si + Fe	...	0.10	0.10	...	...	0.8–1.3	...	...	...	0.05	0.15	remainder
7075 <sup>K</sup>	0.40	0.50	1.2–2.0	0.30	2.1–2.9	0.18–0.28	5.1–6.1	0.20	...	...	0.05	0.15	remainder

<sup>A</sup> Limits are in weight percent maximum unless shown as a range or otherwise stated.

<sup>B</sup> Analysis shall be made for the elements for which limits are shown in this table.

<sup>C</sup> For purposes of determining conformance to these limits, an observed value or a calculated value obtained from analysis shall be rounded to the nearest unit in the last right-hand place of figures used in expressing the specified limit, in accordance with the rounding-off method of Practice E29.

<sup>D</sup> In case of a discrepancy in the values listed in Table 1 with those listed in the *International Alloy Designations and Chemical Composition Limits for Wrought Aluminum and Wrought Aluminum Alloys* (known as the "Teal Sheets"), the composition limits registered with the Aluminum Association and published in the "Teal Sheets" shall be considered the controlling composition. The "Teal Sheets" are available at <http://www.aluminum.org/tealsheets>.

<sup>E</sup> *Others* includes listed elements for which no specific limit is shown as well as unlisted metallic elements. The producer may analyze samples for trace elements not specified in the specification. However, such analysis is not required and may not cover all metallic *Others* elements. Should any analysis by the producer or the purchaser establish that an *Others* element exceeds the limit of *Each* or that the aggregate of several *Others* elements exceeds the limit of *Total*, the material shall be considered non-conforming.

<sup>F</sup> *Other elements*—Total shall be the sum of unspecified metallic elements 0.010 % or more, rounded to the second decimal before determining the sum.

<sup>G</sup> Vanadium 0.05 % max.

<sup>H</sup> The aluminum content shall be calculated by subtracting from 100.00 % the sum of all metallic elements present in amounts of 0.010 % or more each, rounded to the second decimal before determining the sum.

<sup>I</sup> Alloy clad with Alloy 7072.

<sup>J</sup> Composition of cladding alloy as applied during the course of manufacture. The samples from finished tube shall not be required to conform to these limits.

<sup>K</sup> A Zr +Ti limit of 0.25 percent maximum may be used with this alloy designation for extruded and forged products only, but only when the supplier or producer and the purchaser have mutually so agreed. Agreement may be indicated, for example, by reference to a standard, by letter, by order note, or other means which allow the Zr +Ti limit.

<sup>L</sup> Bismuth and lead each 0.40–0.7 %.

<sup>M</sup> Bismuth and lead each 0.20–0.6 %.

E1251 Test Method for Analysis of Aluminum and Aluminum Alloys by Spark Atomic Emission Spectrometry

2.3 *ANSI Standards:*

H35.1/H35.1(M) Alloy and Temper Designation Systems for Aluminum

H35.2 Dimensional Tolerances for Aluminum Mill Products

2.4 *Military Standard:*

MIL-STD-129 Marking for Shipment and Storage

2.5 *AMS Specification:*

AMS-2772 Heat Treatment of Aluminum Alloy Raw Materials

2.6 *Federal Standard:*

Fed. Std. No. 123 Marking for Shipment (Civil Agencies)

### 3. Terminology

#### 3.1 Definitions:

3.1.1 *alclad seamless pipe or alclad seamless tube*—a composite pipe or tube product composed of a seamless aluminum alloy core having on either the inside or the outside surface a metallurgically bonded aluminum or aluminum-alloy coating that is anodic to the core, thus electrolytically protecting the core against corrosion.

3.1.2 *extruded seamless round tube*—an extruded hollow product having a round cross section and a uniform wall thickness, which does not contain any line junctures resulting from method of manufacture.

3.1.3 *producer*—the primary manufacturer of the material.

3.1.4 *seamless pipe*—extruded or drawn seamless tube having certain standardized sizes of outside diameter and wall thickness commonly designated by "Nominal Pipe Sizes" and American National Standards Institute (ANSI) Schedule Numbers. Note that while this is a combined SI and Metric Units

TABLE 2 Tensile Property Limits<sup>A,B</sup>

Temper	Specified Wall Thickness, <sup>C</sup> in.	Tensile Strength, ksi		Yield Strength <sup>D</sup> (0.2 % offset), min, ksi	Elongation in 2 in. or 4 × Diameter, <sup>E</sup> min, %	
		min	max		Full-Section Specimen	Cut-Out Specimen
Aluminum 1060 <sup>F</sup>						
O	0.014–0.500	8.5	13.5	2.5	...	...
H12		10.0	...	4.0	...	...
H14		12.0	...	10.0	...	...
H18		16.0	...	13.0	...	...
H113 <sup>G</sup>		8.5	...	2.5	...	...
Aluminum 1100 <sup>F</sup>						
O	0.010–0.500	11.0	15.5	3.5	...	...
H12		14.0	...	11.0	...	...
H14		16.0	...	14.0	...	...
H16		19.0	...	17.0	...	...
H18		22.0	...	20.0	...	...
H113 <sup>G</sup>		11.0	...	3.5	...	...
Alloy 2011						
T3	0.018–0.049	47.0	...	40.0	...	...
	0.050–0.500	47.0	...	40.0	10	8
T4511	0.018–0.049	44.0	...	25.0	...	...
	0.050–0.259	44.0	...	25.0	20	18
	0.260–0.500	44.0	...	25.0	20	20
T8	0.018–0.500	58.0	...	46.0	10	8
Alloy 2014						
O	0.018–0.500	...	32.0	16.0 max	...	...
T4, T42 <sup>H</sup>	0.018–0.024	54.0	...	30.0	10	...
	0.025–0.049	54.0	...	30.0	12	10
	0.050–0.259	54.0	...	30.0	14	10
	0.260–0.500	54.0	...	30.0	16	12
T6, T62 <sup>H</sup>	0.018–0.024	65.0	...	55.0	7	...
	0.025–0.049	65.0	...	55.0	7	6
	0.050–0.259	65.0	...	55.0	8	7
	0.260–0.500	65.0	...	55.0	9	8
Alloy 2024						
O	0.018–0.500	...	32.0	15.0 max	...	...
T3	0.018–0.024	64.0	...	42.0	10	...
	0.025–0.049	64.0	...	42.0	12	10
	0.050–0.259	64.0	...	42.0	14	10
	0.260–0.500	64.0	...	42.0	16	12
T42 <sup>H</sup>	0.018–0.024	64.0	...	40.0	10	...
	0.025–0.049	64.0	...	40.0	12	10
	0.050–0.259	64.0	...	40.0	14	10
	0.260–0.500	64.0	...	40.0	16	12
Alloy 3003 <sup>F</sup>						
O	0.010–0.024	14.0	19.0	5.0	...	...
	0.025–0.049	14.0	19.0	5.0	30	20
	0.050–0.259	14.0	19.0	5.0	35	25
	0.260–0.500	14.0	19.0	5.0	...	30
H12	0.010–0.500	17.0	...	12.0	...	...
H14	0.010–0.024	20.0	...	17.0	3	...
	0.025–0.049	20.0	...	17.0	5	3
	0.050–0.259	20.0	...	17.0	8	4
	0.260–0.500	20.0	...	17.0	...	...
H16	0.010–0.024	24.0	...	21.0	...	...
	0.025–0.049	24.0	...	21.0	3	2
	0.050–0.259	24.0	...	21.0	5	4
	0.260–0.500	24.0	...	21.0	...	...
H18	0.010–0.024	27.0	...	24.0	2	...
	0.025–0.049	27.0	...	24.0	3	2
	0.050–0.259	27.0	...	24.0	5	3
	0.260–0.500	27.0	...	24.0	...	...
H113 <sup>G</sup>	0.010–0.500	14.0	...	5.0	...	...
Alloy Alclad 3003 <sup>F</sup>						
O	0.010–0.024	13.0	19.0	4.5	...	...
	0.025–0.049	13.0	19.0	4.5	30	20
	0.050–0.259	13.0	19.0	4.5	35	25
	0.260–0.500	13.0	19.0	4.5	...	30
H14	0.010–0.024	19.0	...	16.0	...	...
	0.025–0.049	19.0	...	16.0	5	3
	0.050–0.259	19.0	...	16.0	8	4
	0.260–0.500	19.0	...	16.0	...	...
H18	0.010–0.500	26.0	...	23.0	...	...
H113 <sup>G</sup>	0.010–0.500	13.0	...	4.5	...	...
Alloy 3102 <sup>F</sup>						
O	0.018–0.049	12.0	17.0	4.0	30 <sup>I</sup>	20 <sup>I</sup>

TABLE 2 Continued

Temper	Specified Wall Thickness, <sup>C</sup> in.	Tensile Strength, ksi		Yield Strength <sup>D</sup> (0.2 % offset), min, ksi	Elongation in 2 in. or 4 × Diameter, <sup>E</sup> min, %	
		min	max		Full-Section Specimen	Cut-Out Specimen
	0.050–0.065	12.0	17.0	4.0	35	25
		Alloy Alclad 3102 <sup>F</sup>				
O	0.018–0.049	10.0	17.0	3.5	30 <sup>I</sup>	20 <sup>I</sup> / 25
	0.050–0.065	10.0	17.0	3.5	35	
		Alloy 5005 <sup>F</sup>				
O	0.018–0.500	15.0	21.0	5.0	...	...
		Alloy 5050 <sup>F</sup>				
O	0.010–0.500	18.0	24.0	6.0	...	...
H32	0.010–0.500	22.0	...	16.0	...	...
H34	0.010–0.500	25.0	...	20.0	...	...
H36	0.010–0.500	27.0	...	22.0	...	...
H38	0.010–0.500	29.0	...	24.0	...	...
		Alloy 5052 <sup>F</sup>				
O	0.010–0.450	25.0	35.0	10.0	...	...
H32	0.010–0.450	31.0	...	23.0	...	...
H34	0.010–0.450	34.0	...	26.0	...	...
H36	0.010–0.450	37.0	...	29.0	...	...
H38	0.010–0.450	39.0	...	24.0	...	...
		Alloy 5083 <sup>F</sup>				
O	0.018–0.450	39.0	51.0	16.0	...	14
		Alloy 5086 <sup>F</sup>				
O	0.010–0.450	35.0	46.0	14.0	...	...
H32	0.010–0.450	40.0	...	28.0	...	...
H34	0.010–0.450	44.0	...	34.0	...	...
H36	0.010–0.450	47.0	...	38.0	...	...
		Alloy 5154 <sup>F</sup>				
O	0.010–0.500	30.0	41.0	11.0	10	10
H34	0.010–0.500	39.0	...	29.0	5	5
H38	0.010–0.250	45.0	...	34.0	...	...
		Alloy 5456 <sup>F</sup>				
O	0.018–0.450	41.0	53.0	19.0	...	14
		Alloy 6061				
O	0.018–0.500	...	22.0	14.0 max	15	15
T4	0.025–0.049	30.0	...	16.0	16	14
	0.050–0.259	30.0	...	16.0	18	16
	0.260–0.500	30.0	...	16.0	20	18
T42 <sup>H</sup>	0.025–0.049	30.0	...	14.0	16	14
	0.050–0.259	30.0	...	14.0	18	16
	0.260–0.500	30.0	...	14.0	20	18
T6, T62 <sup>H</sup>	0.025–0.049	42.0	...	35.0	10	8
	0.050–0.259	42.0	...	35.0	12	10
	0.260–0.500	42.0	...	35.0	14	12
		Alloy 6063				
O	0.018–0.500	...	19.0	...	...	...
T4, T42 <sup>H</sup>	0.025–0.049	22.0	...	10.0	16	14
	0.050–0.259	22.0	...	10.0	18	16
	0.260–0.500	22.0	...	10.0	20	18
T6, T62 <sup>H</sup>	0.025–0.049	33.0	...	28.0	12	8
	0.050–0.259	33.0	...	28.0	14	10
	0.260–0.500	33.0	...	28.0	16	12
T83	0.025–0.259	33.0	...	30.0	5	...
T831	0.025–0.259	28.0	...	25.0	5	...
T832	0.025–0.049	41.0	...	36.0	8	5
	0.050–0.259	40.0	...	35.0	8	5
		Alloy 6262				
T6, T62 <sup>H</sup>	0.025–0.049	42.0	...	35.0	10	8
	0.050–0.259	42.0	...	35.0	12	10
	0.260–0.500	42.0	...	35.0	14	12
T9	0.025–0.375	48.0	...	44.0	5	4
		Alloy 7075				
O	0.025–0.049	...	40.0	21.0 max <sup>J</sup>	10	8
	0.050–0.500	...	40.0	21.0 max <sup>J</sup>	12	10
T6, T62 <sup>H</sup>	0.025–0.259	77.0	...	66.0	8	7
	0.260–0.500	77.0	...	66.0	9	8

TABLE 2 Continued

Temper	Specified Wall Thickness, <sup>C</sup> in.	Tensile Strength, ksi		Yield Strength <sup>D</sup> (0.2 % offset), min, ksi	Elongation in 2 in. or 4 × Diameter, <sup>E</sup> min, %	
		min	max		Full-Section Specimen	Cut-Out Specimen
T73 <sup>K</sup>	0.025–0.259	66.0	...	56.0	10	8
	0.260–0.500	66.0	...	56.0	12	10

<sup>A</sup> See Annex A1.  
<sup>B</sup> To determine conformance to this specification, each value for tensile strength and for yield strength shall be rounded to the nearest 0.1 ksi and each value for elongation to the nearest 0.5 % both in accordance with the rounding-off method of Practice E29.  
<sup>C</sup> Coiled tube is generally available with a maximum wall thickness of 0.083 in. and only in nonheat-treatable alloys.  
<sup>D</sup> Yield strength to be determined only on straight tube.  
<sup>E</sup> Elongation of full-section and cut-out sheet-type specimens is measured in 2 in. of cut-out round specimens, in 4× specimen diameter.  
<sup>F</sup> In this alloy tube other than round is produced only in the F (as drawn) and O tempers. Properties for F temper are not specified or guaranteed.  
<sup>G</sup> Beginning with the 1982 issue the requirements for the H112 tempers were replaced by the H113 temper, applicable to other than round tube, which is fabricated by cold-forming annealed round tube and acquires some temper in this forming operation.  
<sup>H</sup> Material in the T42 or T62 tempers is not available from the material producers.  
<sup>I</sup> For specified wall thickness under 0.025 in., elongation is not required.  
<sup>J</sup> Applicable only to round tube. The maximum yield strength for other-than-round tube shall be negotiated.  
<sup>K</sup> Material in this temper exhibits improved resistance to stress corrosion compared to that of the T6 temper. The stress-corrosion resistance capability of individual lots is determined by testing the previously selected tension-test samples in accordance with the applicable electrical conductivity acceptance criteria of Table 3.

TABLE 3 Lot Acceptance Criteria for Resistance to Stress-Corrosion

Alloy and Temper	Lot Acceptance Criteria		Lot Acceptance Status
	Electrical Conductivity, <sup>A,B</sup> % IACS	Level of Mechanical Properties	
7075–T73	40.0 or greater	per specified requirements	acceptable
	38.0 through 39.9	per specified requirements and yield strength does not exceed minimum by more than 11.9 ksi	acceptable
	38.0 through 39.9	per specified requirements but yield strength exceeds minimum by 12.0 ksi or more	unacceptable <sup>C</sup>
	less than 38.0	any level	unacceptable <sup>C</sup>

<sup>A</sup> The electrical conductivity shall be determined in accordance with Practice E1004 in the locations noted below.  
<sup>B</sup> For curved surfaces, the conductivity shall be measured on a machined flat spot; however, for small size tubes, a cut-out piece may be flattened and the conductivity determined.  
<sup>C</sup> When material is found to be unacceptable, it shall be reprocessed (additional precipitation heat treatment or resolution heat treatment and precipitation heat treatment).

Wall Thickness, in.	Location
up through 0.100	surface of tensile sample
0.101 and over	subsurface after removal of approximately 10 % of thickness.

Specification, there are no standard equivalent metric sizes for Pipe. Metric sizes are converted and shown only for user convenience.

3.1.5 *supplier*—jobber or distributor as distinct from producer.

3.1.6 *Definitions*—Refer to Terminology B881 for definitions of other product terms used in this specification.

3.2 *Definitions of Terms Specific to This Standard:*

3.2.1 *capable of*—the test need not be performed by the producer of the material. However, should subsequent testing by the purchaser establish that the material does not meet these requirements, the material shall be subject to rejection.

3.2.2 *drawn seamless tube*—seamless tube that is subjected to drawing after extrusion.

4. Ordering Information

4.1 Orders for material to this specification shall include the following information:

4.1.1 This specification designation (which includes the number, the year, and the revision letter, if applicable),

4.1.2 Quantity in pieces or pounds,

4.1.3 Alloy (Section 7),

4.1.4 Temper (Section 8),

4.1.5 Cross-sectional dimensions (outside diameter and wall thickness, or inside diameter and wall thickness for round tube; for tube other than round, square, rectangular, hexagonal, or octagonal with sharp corners, a drawing is required),

4.1.6 Length (straight or coiled),

4.1.7 Nominal inside diameter of coils and weight or maximum outside diameter, if applicable,

4.1.8 For alloy Alclad 3003 or Alclad 3102 state clad inside or outside (17.1).

4.2 Additionally, orders for material to this specification shall include the following information when required by the purchaser:

4.2.1 For alloys 6061, 6063, and 6262, specify if Press Solution Heat Treatment in accordance with Practice B807/B807M is not acceptable (11.2).

4.2.2 Whether heat treatment in accordance with Practice B918/B918M is required (11.3),

4.2.3 Whether flattening tests are required (Section 9 and Table 4),

4.2.4 Whether flare testing is required (Section 10),

4.2.5 Whether 7075-O material is required to develop requirements for T73 temper (12.3),

4.2.6 When eddy current indications are allowed, the number allowed and the manner of marking (15.1.3.2),

4.2.7 Whether inside cleanness test is required on coiled tubes (16.2) and frequency of testing required,

4.2.8 Whether inspection or witness of inspection and tests by the purchaser's representative is required prior to material shipment (Section 20),

4.2.9 DELETED

4.2.10 Whether marking for identification is required (Section 23), and

4.2.11 Whether Practices B660 applies, and if so, the levels of preservation, packaging, and packing required (Section 24).

4.2.12 Whether 7075 alloy Zr+Ti limit applies (Table 1 Footnote J).

## 5. Materials and Manufacture

5.1 The tube shall be produced by drawing an extruded tube made from hollow extrusion ingot (cast in hollow form or pierced) and extruded by the use of the die and mandrel method.

**TABLE 4 Minimum Outside Diameter Flattening Factor**

Alloy	Temper	Wall Thickness, in.	Minimum Diameter Flattening Factor, $F$	
1100	O	0.014–0.500	2	
	H12	0.014–0.500	3	
	H14	0.014–0.500	6	
	H16	0.014–0.500	8	
3003	O	0.025–0.500	2	
	H12	0.025–0.500	3	
	H14	0.025–0.500	6	
	H16	0.025–0.500	8	
2024	O	0.018–0.049	3	
		0.050–0.500	4	
	T3	0.018–0.500	8	
5052	O	0.010–0.450	3	
	H32	0.010–0.450	6	
	H34	0.010–0.450	8	
5086	O	0.010–0.450	3	
	H32	0.010–0.450	8	
6061	O	0.018–0.120	3	
		0.121–0.238	4	
		0.239–0.500	6	
	T4	0.025–0.500	6	
		T6	0.025–0.500	8
7075	O	0.025–0.049	4	
		0.050–0.259	5	
	T6	0.025–0.259	10	

5.2 The ends of coiled tube shall be crimped or otherwise sealed to avoid contamination during shipment.

## 6. Responsibility for Quality Assurance

6.1 *Responsibility for Inspection and Tests*—Unless otherwise specified in the contract or purchase order, the producer is responsible for the performance of all inspection and test requirements specified herein. The producer may use his own or any other suitable facilities for the performance of the inspection and test requirements specified herein, unless disapproved by the purchaser in the order or at the time of signing the contract. The purchaser shall have the right to perform any of the inspections and tests set forth in this specification where such inspections are deemed necessary to ensure that material conforms to prescribed requirements.

6.2 *Lot Definition*—An inspection lot shall be defined as follows:

6.2.1 For heat-treated tempers an inspection lot shall consist of an identifiable quantity of material of the same mill form, alloy, temper, and nominal dimensions traceable to a heat-treat lot or lots, and subjected to inspection at one time.

6.2.2 For nonheat-treated tempers, an inspection lot shall consist of an identifiable quantity of material of the same mill form, alloy, temper, and nominal dimensions subjected to inspection at one time.

## 7. Chemical Composition

7.1 *Limits*—The tubes shall conform to the chemical composition limits specified in Table 1. Conformance shall be determined by the producer, by taking samples in accordance with Practices E716, when the ingots are poured, and analyzing those samples in accordance with E607, E1251, or E34. At least one sample shall be taken for each group of ingots poured simultaneously from the same source of molten metal. If the producer has determined the chemical composition during pouring of the ingots, they shall not be required to sample and analyze the finished product.

NOTE 3—It is standard practice in the United States aluminum industry to determine conformance to the chemical composition limits prior to further processing of ingots into wrought products. Due to the continuous nature of the process, it is not practical to keep a specific ingot analysis identified with a specific quantity of finished material.

7.2 If it becomes necessary to analyze tubes for conformance to chemical composition limits, the method used to sample the tubes for the determination of chemical composition shall be by agreement between the producer and the purchaser. Analysis shall be performed in accordance with E716, E607, E1251, or E34. The number of samples taken for determination of chemical composition shall be as follows:

7.2.1 When samples are taken from tubes, a sample shall be taken to represent each 4000 lb or fraction thereof of material in the shipment, except that not more than one sample shall be required per piece.

7.3 Other methods of analysis or in the case of dispute may be by agreement between the producer and the purchaser.

NOTE 4—It is difficult to obtain a reliable analysis of each of the components of clad materials using material in its finished state. A reasonably accurate determination of the core composition can be made if

the cladding is substantially removed prior to analysis. The cladding composition is more difficult to determine because of the relatively thin layer and because of diffusion of core elements to the cladding. The correctness of cladding alloy used can usually be verified by a combination of metallographic examination and spectrochemical analysis of the surface at several widely separated points.

## 8. Tensile Properties of Material as Supplied

8.1 *Limits*—Tube shall conform to the tensile property requirements specified in Table 2.

### 8.2 Number of Specimens:

8.2.1 For tubes having a nominal weight of less than 1 lb/linear ft, one tension test specimen shall be taken for each 1000 lb, or fraction thereof, in a lot.

8.2.2 For tubes having a nominal weight of 1 lb or more/linear ft, one tension test specimen shall be taken for each 1000 ft, or fraction thereof, in a lot.

8.2.3 If the shipment contains tubes of more than one alloy, temper, or size, only those tubes of the same alloy, temper, and size shall be grouped for the purpose of selecting tension test specimens. Other procedures for selecting samples may be employed if agreed upon by the producer and the purchaser.

8.3 *Test Specimens*—Geometry of test specimens and the location in the product from which they are taken shall be as specified in Test Method B557.

8.4 *Test Methods*—The tension tests shall be made in accordance with Test Method B557.

## 9. Flattening Properties

9.1 *Limits*—When specified by the purchaser at the time of placing the order, round tube in alloys and tempers listed in Table 4 shall be tested in full section and withstand, without cracking, the minimum outside diameter flattening factor specified in Table 4.

### 9.2 Number of Specimens:

9.2.1 For tubes having a nominal weight of less than 1 lb/linear ft, one flattening test specimen shall be taken for each 1000 lb or fraction thereof in a lot.

9.2.2 For tubes having a nominal weight of 1 lb or more/linear ft, one flattening test specimen shall be taken for each 1000 ft, or fraction thereof, in a lot.

9.3 *Methods of Test*—Flattening test specimens shall be flattened sidewise under a gradually applied load so as to give a uniform radius of bend until the minimum outside diameter under load is not more than  $F$  times the wall thickness of the tube as specified in Table 4.

9.4 *Alternative Bend Test*—In case the tube does not flatten so as to give a uniform radius of bend, suitable jigs may be used to bring about this result, or a section of tube of not less than  $\frac{1}{2}$  in. in length, with the subtended arc not greater than one half nor less than one third of the circumference of the original tube, shall be removed from the material in question and without further treatment shall be bent around a mandrel having a diameter  $N$  times the wall thickness of the tube as specified in Table 5. The bend shall be made with the pin placed on the inside surface of the specimen, with the longi-

TABLE 5 Minimum Bend Factor

Alloy	Temper	Wall Thickness, in.	Minimum Bend Factor, $N$
2024	T3	0.018–0.128	6
5052	O	0.010–0.249	1
	H32	0.010–0.249	4
	H34	0.010–0.249	6
5086	O	0.010–0.249	1
	H32	0.010–0.249	6
6061	O	0.018–0.120	1
		0.121–0.238	2
		0.239–0.500	4
	T4	0.025–0.500	4
7075	T6	0.025–0.500	6
		0.025–0.125	4
		0.126–0.259	6
7075	T6	0.025–0.062	8
		0.063–0.125	10
		0.126–0.259	12

tudinal axis of the pin and the specimen parallel. The bend shall be continued until the specimen encloses at least 180° of the pin.

9.4.1 After the flattening test, the outer surface of the tube shall be examined visually for cracks. Any evidence of cracking shall be cause for rejection.

## 10. Flaring Properties

10.1 *Limits*—When specified by the purchaser at the time of placing the order, round tube in straight lengths in alloys and tempers 1100-H14, 3003-H14, 5052-O, and 6061-O with a nominal outside diameter of 0.375 in. or less, shall be capable of being double-flared to the configuration of Fig. 1, and with a nominal outside diameter over 0.375 in. shall be capable of being single-flared to the configuration of Fig. 2, without formation of cracks or other defects clearly visible to the unaided eye.

10.2 *Number of Specimens*—When flare testing is specified in the order, for tube sizes having a nominal weight of less than 1 lb/linear ft, one flaring test specimen shall be taken for each 1000 lb or fraction thereof in the lot. For tubes having a nominal weight of 1 lb or more/linear ft, one flaring test specimen shall be taken for each 1000 ft, or fraction thereof, in the lot.

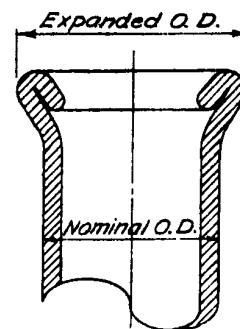

FIG. 1 Double Flare

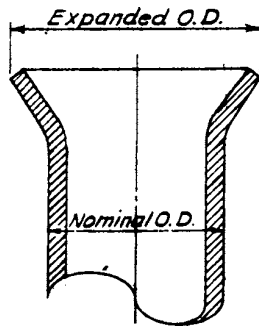

FIG. 2 Single Flare

10.3 *Preparation of Specimens*—Specimens for flaring may be cut from any portion of the tube, or an entire tube may be used as a specimen. The end of the specimen to be flared shall be cut square, with the cut end smooth and free from burrs, but not rounded, except for sizes 0.375 in. and under.

10.4 *Test Methods*—The specimen shall be forced axially with steady pressure over a hardened and polished tapered steel pin having a 74° included angle, to produce a flare having the permanent expanded outside diameter specified in Table 6.

## 11. Heat Treatment

11.1 For the production of T3, T4, T6, T7, and T8-type tempers, except as noted in 11.2 or 11.3, shall be in accordance with AMS 2772.

11.2 Unless otherwise specified (4.2.1), alloys, 6061, 6063, and 6262 may be Extrusion Press Solution Heat Treated in accordance with Practice B807/B807M for the production of T4 and T6-type tempers, as applicable.

11.3 When specified (4.2.2), heat treatment for the production of T3, T4, T6, T7, and T8-type tempers shall be in accordance with Practice B918/B918M.

## 12. Producer's Confirmation of Heat-Treat Response

12.1 In addition to the requirements of Section 8, material in Alloys 2014, 2024, 6061, and 6063 produced in the O or F temper (within the size limits specified in Table 2) shall, after proper solution heat treatment and natural aging for not less than 4 days at room temperature, conform to the properties specified in Table 2 for T42 temper material. The heat-treated samples may be tested prior to 4 days natural aging, but if they

TABLE 6 Flare<sup>A</sup> Dimensions, in.

Nominal OD	Expanded OD, min	Nominal OD	Expanded OD, min
0.125	0.224	0.750	0.937
0.188	0.302	1.000	1.187
0.250	0.359	1.250	1.500
0.312	0.421	1.500	1.721
0.375	0.484	1.750	2.106
0.500	0.656	2.000	2.356
0.625	0.781		

<sup>A</sup> Tube with intermediate nominal diameters shall meet the same requirements as those for the next largest diameter. Tube with nominal diameters larger than 2.000 or less than 0.125 in. shall meet requirements as agreed by the purchaser and producer.

fail to conform to the T42 temper properties, the tests may be repeated after completion of 4 days natural aging without prejudice.

12.2 Alloy 7075 material produced in the O or F temper (within the size limits specified in Table 2) shall, after proper solution heat treatment and precipitation heat treatment, conform to the properties specified in Table 2 for T62 temper material.

12.3 When specified, 7075-O material (within the size limits specified in Table 2) shall, after proper solution and precipitation heat treatment, conform to the properties specified for T73 temper in Table 2 and Section 14.

12.4 *Number of Specimens*—The number of specimens from each lot of O temper material and F temper material to verify conformance with Section 12 shall be as specified in 8.2.

## 13. Heat Treatment and Reheat Treatment Capability

13.1 As-received material in the O or F temper and in Alloys 2014, 2024, 6061, and 6063 (within the size limitations specified in Table 2 and without the imposition of cold work) shall, after proper solution heat treatment and natural aging for not less than 4 days at room temperature, conform to the properties specified in Table 2 for T42 temper material.

13.2 As-received Alloy 7075 material in the O or F temper (within the size limitations specified in Table 2 and without the imposition of cold work) shall, after proper solution and precipitation heat treatment, conform to the properties specified in Table 2 for the T62 temper.

13.3 Material in Alloys and Tempers 2014-T4, T6; 2024-T8; and 6063-T4, T6 shall, after proper resolution heat treatment and natural aging for not less than 4 days at room temperature, conform to the properties specified in Table 2 for the T42 temper.

NOTE 5—Beginning with the 1975 revision of B210, 6061-T4 and T6 were deleted from this paragraph because experience has shown the reheat-treated material may develop large recrystallized grains and may fail to develop the tensile properties shown in Table 2.

13.4 Alloy 7075 material in T6 and T73 tempers shall, after proper resolution heat treatment and precipitation heat treatment, conform to the properties specified in Table 2 for the T62 temper.

13.5 Material in T4 and T42 tempers shall, after proper precipitation heat treatment, conform to the properties specified in Table 2 for the T6 and T62 tempers, respectively.

## 14. Stress-Corrosion Resistance

14.1 For lot acceptance purposes, resistance to stress-corrosion cracking for each lot of 7075-T73 material shall be established by testing the previously selected tension-test samples to the criteria shown in Table 3.

14.2 The producer shall maintain records of all lots so tested and make them available for examination at the producer's facility.

## 15. Test for Leaks

15.1 Tube shall be tested for leaks by one of the following methods at the option of the producer.

15.1.1 *Method 1*—Tubes 1½ in. or less in diameter shall be tested pneumatically at not less than 60 psi air pressure while immersed in water or other suitable liquid. Any evidence of leakage shall be cause for rejection.

15.1.2 *Method 2*—Tubes 1½ in. or less in diameter shall be tested pneumatically at not less than 90 psi air pressure with a gage that will indicate loss of pressure. There shall not be any loss of pressure during a test period of at least 15-s duration.

15.1.3 *Method 3*—Tubes shall be subjected to an eddy-current test in accordance with the procedures described in Practice E215. Reference standards or secondary standards having equivalent eddy-current response shall serve to define acceptance-rejection limits. These reference standards are acceptable for testing any strain-hardened temper of the nonheat-treatable alloys and the F temper of heat-treatable alloys of Table 2 in tubes 1½ in. or less in diameter having a maximum wall thickness of 0.083 in.

15.1.3.1 For *straight lengths* of tube reference standards described in Appendixes X1 and X2 of Practice E215 shall be used to standardize the equipment. Tubes 1½ in. or less in diameter and maximum wall thickness of 0.083 in. that produce eddy-current indications less than those from the 2A holes of the applicable reference standard or an equivalent secondary standard shall be acceptable. Any tube having a discontinuity that produces an eddy-current indication equal to or greater than those from the 2A holes of the applicable reference standard or an equivalent secondary standard shall be rejected.

15.1.3.2 For *coiled tube* secondary standards having an equivalent eddy-current response to a No. 70 (0.028 in.) and No. 60 (0.040 in.) drill holes shall be used to standardize the equipment. Tubes ¾ to 1 in., incl, in diameter and maximum wall thickness of 0.083 in. that produce eddy-current indications less than those from the No. 60 hole of the secondary standard shall be acceptable. Any tube that produces an indication equal to or greater than those from the No. 60 hole of the secondary standard shall be rejected. Setup procedures shall include a check to ensure that tubes containing defects giving responses equal to or greater than that from a No. 60 hole are rejected at the speed of inspection. Tube in long coils may contain up to a specified number of defects per coil when agreed upon between the producer and purchaser. In cases where a specified number of defects per coil is allowed, the need for marking such defects in a coil shall be handled as agreed upon between the producer and purchaser.

### 16. Special Requirements for Coiled Tubes

16.1 *Expansion Test*—Coiled tube in the annealed temper only shall be capable of being expanded on a hardened ground tapered steel pin having an included angle of 60°, to the following amounts, without signs of cracks, ruptures, or other defects clearly visible to the unaided eye:

Nominal Outside Diameter, in.	Expansion of Outside Diameter, %
Up through 0.750	40
0.751 and over	30

NOTE 6—Other expansion capabilities may be required in special cases but shall be the subject of negotiation between the producer and the purchaser.

16.2 *Inside Cleanliness Requirements and Test*—When specified by the purchaser at the time of placing the order, the inside of coiled tube in the annealed temper only shall be sufficiently clean so that, when a test sample of 50 ft or a minimum of 375 in.<sup>2</sup> internal surface is washed with 1,1,1-trichloroethane or trichloroethylene or equivalent, the residue remaining upon evaporation of the solvent shall not exceed 0.002 g/ft<sup>2</sup> of interior surface.

16.2.1 To perform the test a measured quantity of the solvent shall be pulled through the tube into a flask which is, in turn, attached to an aspirator or vacuum pump. The solvent shall then be transferred to a weighed container (crucible, evaporating dish, or beaker). The solvent in the container shall be evaporated to dryness on a low-temperature hot plate or steam bath. Overheating of the container shall be avoided to prevent charring of the residue. The container shall then be dried in an oven at 100 to 110°C for 10 min, cooled in a desiccator, and weighed. A blank determination shall be run on the measured quantity of solvent, and the gain in weight for the blank shall be subtracted from the weighings of the residue sample. The corrected weight shall then be calculated in grams of residue per internal area of tube.

16.2.2 The quantity of the solvent used may vary with the size of tube being examined. A minimum quantity of 100 mL should be used for diameters up to ½ in. and should be increased proportionately for the larger sizes. The quantity of solvent used for the blank run shall be the same as that used for the actual examination of the tube sample.

16.2.3 In performing the test, care must be exercised to clean the outside surface of the end of the sample to be immersed in the solvent. The sample must be prepared in such a manner as to prevent the inclusion in the residue of aluminum chips or dust resulting from the cutting of the sample.

## 17. Cladding

17.1 The aluminum-alloy cladding of Alloy Alclad 3003 and Alloy Alclad 3102 tubes shall comprise either the inside surface (only) or the outside surface (only) of the tube as specified. The purchaser shall specify whether “clad inside” or “clad outside” tubes are required.

17.2 The Alloy Alclad 3003 and Alloy Alclad 3102 tubes shall be fabricated in such a manner that the cladding thickness will be approximately 10 % of the specified composite wall thickness for “clad inside” and 7 % for “clad outside.”

17.3 When the thickness of the cladding is to be determined on finished tubes, transverse cross sections of at least three tubes from the lot shall be polished for examination with a metallurgical microscope. Using a magnification of 100×, the cladding thickness at four points, 90° apart, in each sample shall be measured and the average of the twelve measurements shall be taken as the thickness. In the case of tubes having a

diameter larger than can properly be mounted for polishing and examination, the portions of the cross section polished for examination may consist of an arc about ½ in. in length.

## 18. Dimensional Tolerances

18.1 Variations from the specified or nominal dimensions shall not exceed the permissible variations prescribed in tables of ANSI H35.2 in accordance with Table 7.

18.2 *Sampling for Inspection*—Examinations for dimensions shall be made to ensure conformance to the tolerances specified.

## 19. General Quality

19.1 Unless otherwise specified, the material shall be supplied in the mill finish and shall be uniform as defined by the requirements of this specification and shall be commercially sound. Any requirement not so covered is subject to negotiation between producer and purchaser.

19.2 Each tube shall be examined to determine conformance to this specification with respect to general quality and identification marking. On approval of the purchaser, however, the producer may use a system of statistical quality control for such examinations.

## 20. Source Inspection

20.1 If the purchaser desires that his representative inspect or witness the inspection and testing of the material prior to shipment, such agreement shall be made by the purchaser and the producer as part of the purchase contract.

20.2 When such inspection or witness of inspection and testing is agreed upon, the producer or supplier shall afford the purchaser's representative all reasonable facilities to satisfy him that the material meets the requirements of this specification. Inspection and tests shall be conducted so there is no unnecessary interference with the producer's operations.

## 21. Retest and Rejection

21.1 If any material fails to conform to all the applicable requirements of this specification, it shall be cause for rejection of the inspection lot.

**TABLE 7 Index to Tables of Tolerances in ANSI H35.2**

Table No.	Title
12.20	Diameter-Drawn, Round Tube
12.21	Width and Depth, Drawn Square, Rectangular, Hexagonal and Octagonal Tube
12.22	Diameter-Drawn, Oval, Elliptical, and Streamline Tube
12.23	Corner Radii-Drawn Tube
12.24	Wall Thickness-Drawn Round and Other-than-Round Tube
12.25	Straightness-Drawn Tube
12.26	Twist-Drawn Tube
12.27	Length-Drawn Tube
12.28	Flatness, (Flat Surfaces) Other-than-Round Drawn Tube
12.29	Squareness of Cut Ends-Drawn Tube
12.30	Angularity-Drawn Tube
12.31	Surface Roughness-Drawn Tube
12.32	Dents-Drawn Tube

21.2 When there is evidence that a failed specimen was not representative of the inspection lot and when no other sampling plan is provided or approved by the purchaser through the contract or purchase order, at least two additional specimens shall be selected to replace each test specimen that failed. All specimens so selected for retest shall meet the requirements of the specification or the lot shall be subject to rejection.

21.3 Material in which defects are discovered subsequent to inspection may be rejected.

21.4 If material is rejected by the purchaser, the producer or supplier is responsible only for replacement of the material to the purchaser. As much as possible of the rejected material shall be returned to the producer or supplier.

## 22. Certification

22.1 The producer or supplier shall furnish to the purchaser a certificate stating that the material has been sampled, tested, and inspected in accordance with this specification, and has met the requirements. In addition, all tests reports required by this specification shall be supplied with the certification.

## 23. Identification Marking of Product

23.1 When specified in the contract or purchase order all tubes in straight lengths shall be marked in accordance with Practice B666/B666M and the marking legend shall include the word "seamless."

23.2 The foregoing requirements are minimum; marking systems that involve added information, larger characters, and greater frequencies are acceptable under this specification.

## 24. Packaging and Package Marking

24.1 The material shall be packaged to provide adequate protection during normal handling and transportation and each package shall contain only one size, alloy, and temper of material unless otherwise agreed. The type of packing and gross weight of containers shall, unless otherwise agreed upon, be at the producer's or supplier's discretion, provided that they are such as to ensure acceptance by common or other carriers for safe transportation at the lowest rate to the delivery point.

24.2 Each shipping container shall be marked with the purchase order number, material size, specification number, alloy and temper, gross and net weights, and the producer's name or trademark.

24.3 When specified in the contract or purchase order, material shall be preserved, packaged, and packed in accordance with the requirements of Practice B660. The applicable levels shall be as specified in the contract or order. Marking for shipment of such material shall be in accordance with Fed. Std. No. 123 for civil agencies and MIL-STD-129 for military agencies.

## 25. Keywords

25.1 aluminum alloy; aluminum-alloy drawn seamless tubes

## ANNEXES

## (Mandatory Information)

## A1. BASIS FOR INCLUSION OF PROPERTY LIMITS

A1.1 Mechanical property limits are established in accord with Section 6, Standards Section, of the most current edition of the Aluminum Standards and Data and the latest edition of the Aluminum Association publication “Tempers for Aluminum and Aluminum Alloy Products (Yellow and Tan Sheets)”.

A1.2 Limits are based on a statistical evaluation of the data indicating that at least 99 % of the population obtained from all standard material meets the limit with 95 % confidence. For the products described, mechanical property limits are based on the statistical analyses of at least 100 tests from at least 5 cast lots of standard production material with no more than 10 observations from a given heat treat or inspection lot. Mechanical properties limits for press solution heat treated products have specific additional requirements which are provided in the “Tempers for Aluminum and Aluminum Alloy Products”.

A1.3 Limits denoted as “Tentative” by the Aluminum Association may be included. Requirements for tentative property registrations are defined in the latest edition of the Aluminum Association publication “Tempers for Aluminum and Aluminum Alloy Products”. Tentative property limits are established at levels at which at least 99 % of the data conform at a confidence level of 95 %. Tentative property limits, which are subject to revision, shall be based on a statistical analysis of at least 30 tests from at least 3 cast lots of standard production material with no more than 10 observations from a given heat treat or inspection lot. Where tentative property limits are listed, they shall be shown in italics and footnoted as Tentative in the standard.

A1.4 All tests are performed in accordance with the appropriate ASTM Test Methods.

## A2. ACCEPTANCE CRITERIA FOR INCLUSION OF NEW ALUMINUM AND ALUMINUM ALLOYS IN THIS SPECIFICATION

A2.1 Prior to acceptance for inclusion in this specification, the composition of wrought or cast aluminum or aluminum alloy shall be registered in accordance with ANSI H35.1/H35.1(M). The Aluminum Association holds the Secretariat of ANSI H35 Committee and administers the criteria and procedures for registration.

A2.2 If it is documented that the Aluminum Association could not or would not register a given composition, an alternative procedure and the criteria for acceptance shall be as follows:

A2.2.1 The designation submitted for inclusion does not utilize the same designation system as described in ANSI H35.1/H35.1(M). A designation not in conflict with other designation systems or a trade name is acceptable.

A2.2.2 The aluminum or aluminum alloy has been offered for sale in commercial quantities within the prior twelve months to at least three identifiable users.

A2.2.3 The complete chemical composition limits are submitted.

A2.2.4 The composition is, in the judgment of the responsible subcommittee, significantly different from that of any other aluminum or aluminum alloy already in the specification.

A2.2.5 For codification purposes, an alloying element is any element intentionally added for any purpose other than grain refinement and for which minimum and maximum limits are specified. Unalloyed aluminum contains a minimum of 99.00 % aluminum.

A2.2.6 Standard limits for alloying elements and impurities are expressed to the following decimal places:

Less than 0.001 %	0.000X
0.001 to but less than 0.01 %	0.00X
0.01 to but less than 0.10 %	
Unalloyed aluminum made by a refining process	0.0XX
Alloys and unalloyed aluminum not made by a refining process	0.0X
0.10 through 0.55 %	0.XX
(It is customary to express limits of 0.30 through 0.55 % as 0.X0 or 0.X5)	
Over 0.55 %	0.X, X.X, and so forth.

(except that combined Si + Fe limits for 99.00 % minimum aluminum must be expressed as 0.XX or 1.XX)

A2.2.7 Standard limits for alloying elements and impurities are expressed in the following sequence: Silicon; Iron; Copper; Manganese; Magnesium; Chromium; Nickel; Zinc; Titanium (Note A2.1); Other Elements, Each; Other Elements, Total; Aluminum (Note A2.2).

NOTE A2.1—Additional specified elements having limits are inserted in alphabetical order of their chemical symbols between Titanium and Other Elements, Each, or are specified in footnotes.

NOTE A2.2—Aluminum is specified as *minimum* for unalloyed aluminum and as a *remainder* for aluminum alloys.

**SPECIFICATION FOR ALUMINUM AND  
ALUMINUM-ALLOY ROLLED OR COLD-FINISHED BAR,  
ROD, AND WIRE**



**SB-211/SB-211M**

(Identical with ASTM Specification B211/B211M-19 except that certification and test reports have been made mandatory.)

ASME NORMDOC.COM : Click to view the full PDF of ASME BPVC.II.B (ASME BPVC Section II part B) 2025

# Specification for Aluminum and Aluminum-Alloy Rolled or Cold Finished Bar, Rod, and Wire

## 1. Scope

1.1 This specification covers rolled or cold-finished bar, rod, and wire in alloys (Note 1) and tempers as shown in Table 2 [Table 3].

NOTE 1—Throughout this specification use of the term *alloy* in the general sense includes aluminum as well as aluminum alloy.

NOTE 2—The term *cold finished* is used to indicate the type of surface finish, sharpness of angles, and dimensional tolerances produced by drawing through a die.

NOTE 3—See Specification B221 [B221M] for aluminum and aluminum-alloy extruded bars, rods, wire, shapes, and tubes; and Specification B316/B316M for aluminum and aluminum-alloy rivet and cold-heading wire and rods.

1.2 Alloy and temper designations are in accordance with ANSI H35.1/H35.1M. The equivalent UNS alloy designations are those of Table 1 preceded by A9, for example, A91100 for aluminum 1100 in accordance with Practice E527.

1.3 For acceptance criteria for inclusion of new aluminum and aluminum alloys in this specification, see Annex A2.

1.4 *This international standard was developed in accordance with internationally recognized principles on standardization established in the Decision on Principles for the Development of International Standards, Guides and Recommendations issued by the World Trade Organization Technical Barriers to Trade (TBT) Committee.*

## 2. Referenced Documents

2.1 The following documents of the issue in effect on date of material purchase form a part of this specification to the extent referenced herein:

### 2.2 ASTM Standards:

- B221 Specification for Aluminum and Aluminum-Alloy Extruded Bars, Rods, Wire, Profiles, and Tubes
- B221M Specification for Aluminum and Aluminum-Alloy Extruded Bars, Rods, Wire, Profiles, and Tubes (Metric)
- B316/B316M Specification for Aluminum and Aluminum-Alloy Rivet and Cold-Heading Wire and Rods
- B557 Test Methods for Tension Testing Wrought and Cast Aluminum- and Magnesium-Alloy Products
- B557M Test Methods for Tension Testing Wrought and Cast Aluminum- and Magnesium-Alloy Products (Metric)
- B594 Practice for Ultrasonic Inspection of Aluminum-Alloy Wrought Products
- B660 Practices for Packaging/Packing of Aluminum and Magnesium Products
- B666/B666M Practice for Identification Marking of Aluminum and Magnesium Products
- B881 Terminology Relating to Aluminum- and Magnesium-Alloy Products
- B918/B918M Practice for Heat Treatment of Wrought Aluminum Alloys
- B985 Practice for Sampling Aluminum Ingots, Billets, Castings and Finished or Semi-Finished Wrought Aluminum Products for Compositional Analysis
- E29 Practice for Using Significant Digits in Test Data to Determine Conformance with Specifications
- E290 Test Methods for Bend Testing of Material for Ductility
- E527 Practice for Numbering Metals and Alloys in the Unified Numbering System (UNS)
- E607 Test Method for Atomic Emission Spectrometric Analysis Aluminum Alloys by the Point to Plane Technique Nitrogen Atmosphere (Withdrawn 2011)
- E716 Practices for Sampling and Sample Preparation of Aluminum and Aluminum Alloys for Determination of

TABLE 1 Chemical Composition Limits<sup>A,B,C,D</sup>

Alloy	Si	Fe	Cu	Mn	Mg	Cr	Ni	Zn	Ti	Bi	Pb	Sn	Other Elements <sup>E</sup>		Al, min
													Each	Total <sup>F</sup>	
1100 <sup>G</sup>	0.95 Si + Fe	0.05–0.20	0.05	...	...	...	...	0.10	...	...	...	...	0.05	0.15	99.00 <sup>G</sup>
2011	0.40	0.7	5.0–6.0	...	...	...	...	0.30	...	0.20–0.6	0.20–0.6	...	0.05	0.15	rem
2111	0.40	0.7	5.0–6.0	...	...	...	...	0.30	...	0.20–0.8	...	0.10–0.50	0.05	0.15	rem
2014	0.50–1.2	0.7	3.9–5.0	0.40–1.2	0.20–0.8	0.10	...	0.25	0.15	...	...	...	0.05	0.15	rem
2017	0.20–0.8	0.7	3.5–4.5	0.40–1.0	0.40–0.8	0.10	...	0.25	0.15	...	...	...	0.05	0.15	rem
2024	0.50	0.50	3.8–4.9	0.30–0.9	1.2–1.8	0.10	...	0.25	0.15	...	...	...	0.05	0.15	rem
2219	0.20	0.30	5.8–6.8	0.20–0.40	0.02	...	...	0.10	0.02–0.10	...	...	...	0.05 <sup>H</sup>	0.15 <sup>H</sup>	rem
3003	0.6	0.7	0.05–0.20	1.0–1.5	...	...	...	0.10	...	...	...	...	0.05	0.15	rem
4032	11.0–13.5	1.0	0.50–1.3	...	0.8–1.3	0.10	0.5–1.3	0.25	...	...	...	...	0.05	0.15	rem
5052	0.25	0.40	0.10	0.10	2.2–2.8	0.15–0.35	...	0.10	...	...	...	...	0.05	0.15	rem
5056	0.30	0.40	0.10	0.05–0.20	4.5–5.6	0.05–0.20	...	0.10	...	...	...	...	0.05	0.15	rem
5154	0.25	0.40	0.10	0.10	3.1–3.9	0.15–0.35	...	0.20	0.20	...	...	...	0.05	0.15	rem
6013	0.6–1.0	0.50	0.6–1.1	0.20–0.8	0.8–1.2	0.10	...	0.25	0.10	...	...	...	0.05	0.15	rem
6020	0.40–0.9	0.50	0.30–0.9	0.35	0.6–1.2	0.15	...	0.20	0.15	...	0.05	0.9–1.5	0.05	0.15	rem
6026	0.6–1.4	0.7	0.20–0.50	0.20–1.0	0.6–1.2	0.30	...	0.30	0.20	0.50–1.5	0.40	0.05	0.05	0.15	rem
6061	0.40–0.8	0.7	0.15–0.40	0.15	0.8–1.2	0.04–0.35	...	0.25	0.15	...	...	...	0.05	0.15	rem
6110	0.7–1.5	0.8	0.20–0.7	0.20–0.7	0.50–1.1	0.04–0.25	...	0.30	0.15	...	...	...	0.05	0.15	rem
6262	0.40–0.8	0.7	0.15–0.40	0.15	0.8–1.2	0.04–0.14	...	0.25	0.15	0.40–0.7	0.40–0.7	...	0.05	0.15	rem
7075	0.40	0.50	1.2–2.0	0.30	2.1–2.9	0.18–0.28	...	5.1–6.1	0.20	...	...	...	0.05	0.15	rem

<sup>A</sup> In case of any discrepancy in the values listed in this table when compared with those listed in the “Teal Sheets” (International Alloy Designations and Chemical Composition Limits for Wrought Aluminum and Wrought Aluminum Alloys), the composition limits registered with The Aluminum Association and published in the “Teal Sheets” shall be considered the controlling composition. The “Teal Sheets” are available at <http://www.aluminum.org/tealsheets>.

<sup>B</sup> Limits are in mass percent maximum unless otherwise shown.

<sup>C</sup> Analysis shall be made for the elements for which limits are shown in this table.

<sup>D</sup> For purposes of determining conformance to these limits, an observed value or a calculated value obtained from analysis shall be rounded to the nearest unit in the last right-hand place of figures used in expressing the specified limit, in accordance with the rounding-off method of Practice E29.

<sup>E</sup> *Others* includes listed elements for which no specific limit is shown as well as unlisted metallic elements. The producer may analyze samples for trace elements not specified in the specification. However, such analysis is not required and may not cover all metallic *Others* elements. Should any analysis by the producer or the purchaser establish that an *Others* element exceeds the limit of *Each* or that the aggregate of several *Others* elements exceeds the limit of *Total*, the material shall be considered non-conforming.

<sup>F</sup> *Other Elements—Total*: Total shall be the sum of unspecified metallic elements 0.010 % or more each, rounded to the second decimal before determining the sum.

<sup>G</sup> The aluminum content is the difference between 100.00 % and the sum of all other metallic elements and silicon present in amounts of 0.010 % or more each, rounded to the second decimal before determining the sum.

<sup>H</sup> Vanadium 0.05–0.15 % zirconium 0.10–0.25 %. The total for other elements does not include vanadium and zirconium.

### Chemical Composition by Spark Atomic Emission Spectrometry

E1004 Test Method for Determining Electrical Conductivity

Using the Electromagnetic (Eddy Current) Method

E1251 Test Method for Analysis of Aluminum and Aluminum Alloys by Spark Atomic Emission Spectrometry

E3061 Test Method for Analysis of Aluminum and Aluminum Alloys by Inductively Coupled Plasma Atomic Emission Spectrometry (Performance Based Method)

G47 Test Method for Determining Susceptibility to Stress-Corrosion Cracking of 2XXX and 7XXX Aluminum Alloy Products

### 2.3 ANSI Standards:

H35.1/H35.1M Alloy and Temper Designation Systems for Aluminum

H35.2 [H35.2M] Dimensional Tolerances for Aluminum Mill Products

### 2.4 Federal Standard:

Fed. Std. No. 123 Marking for Shipment (Civil Agencies)

### 2.5 Military Standard:

MIL-STD-129 Marking for Shipment and Storage

### 2.6 Aerospace Material Specification:

AMS 2772 Heat Treatment of Aluminum Alloy Raw Materials

### 2.7 The Aluminum Association:

International Alloy Designations and Chemical Composition Limits for Wrought Aluminum and Wrought Aluminum Alloys (“Teal Sheets”)

### 2.8 Other Standards:

CEN EN 14242 Aluminium and Aluminium Alloys—Chemical Analysis—Inductively Coupled Plasma Optical Emission Spectral Analysis

## 3. Terminology

### 3.1 Definitions:

3.1.1 Refer to Terminology B881 for definitions of product terms in this specification.

3.1.2 *flattened and slit wire*—Flattened wire which has been slit to obtain square edges.

### 3.2 Definitions of Terms Specific to This Standard:

TABLE 2 Mechanical Property Limits<sup>A</sup> (US Customary)

Temper	Specified Diameter or Thickness, in.	Tensile Strength, ksi		Yield Strength <sup>B</sup> (0.2 % offset), min, ksi	Elongation <sup>B</sup> in 2 in. or 4× Diameter, min %
		min	max		
<b>Aluminum 1100</b>					
O	0.124 and under	11.0	15.5	...	...
	0.125 and over	11.0	15.5	3.0	25
H12	0.374 and under	14.0	...	...	...
H14	0.374 and under	16.0	...	...	...
H16	0.374 and under	19.0	...	...	...
H18	0.374 and under	22.0	...	...	...
H112	all	11.0	...	3.0	...
F	all	<sup>D</sup>	...	<sup>D</sup>	...
<b>Alloy 2011</b>					
T3	0.125–1.500	45.0	...	38.0	10
	1.501–2.000	43.0	...	34.0	12
	2.001–3.500	42.0	...	30.0	12
T4 and T451 <sup>E</sup>	0.125–8.000	40.0	...	18.0	16
T6 and T651 <sup>E</sup>	0.375–6.500	54.0	...	40.0	10
T8	0.125–3.250	54.0	...	40.0	10
<b>Alloy 2111</b>					
T8	0.500–3.500	52.0	...	38.0	10
<b>Alloy 2014<sup>F</sup></b>					
O	0.124 and under	...	35.0	...	...
	0.125–8.000	...	35.0	...	12
T4, T42 <sup>G</sup> , & T451 <sup>E</sup>	0.124 and under	55.0	...	...	...
	0.125–8.000 <sup>H</sup>	55.0	...	32.0	16
T6, T62 <sup>G</sup> , & T651 <sup>E</sup>	0.124 and under	65.0	...	...	...
	0.125–8.000 <sup>H</sup>	65.0	...	55.0	8
<b>Alloy 2017<sup>F</sup></b>					
O	0.124 and under	...	35.0	...	...
	0.125–8.000	...	35.0	...	16
T4, T42 <sup>G</sup> , & T451 <sup>E</sup>	0.124 and under	55.0	...	...	...
	0.125–8.000 <sup>I</sup>	55.0	...	32.0	12
<b>Alloy 2024<sup>F</sup></b>					
O	0.124 and under	...	35.0	...	...
	0.125–8.000	...	35.0	...	16
T36	0.124 and under	69.0	...	...	...
	0.125–0.375	69.0	...	52.0	10
T4 <sup>J</sup>	0.124 and under	62.0	...	...	...
	0.125–0.499	62.0	...	45.0 <sup>J</sup>	10
	0.500–4.500 <sup>H</sup>	62.0	...	42.0 <sup>J</sup>	10
	4.501–6.500 <sup>K</sup>	62.0	...	40.0	10
	6.501–8.000 <sup>K</sup>	58.0	...	38.0	10
T42 <sup>G</sup>	0.124 and under	62.0	...	...	...
T42 <sup>G</sup>	0.125–1.000	62.0	...	40.0	10
	1.001–6.500 <sup>H</sup>	62.0	...	40.0	10
T351 <sup>E</sup>	0.500–6.500 <sup>H</sup>	62.0	...	45.0	10
	6.501–8.000	62.0	...	45.0	9
T6	0.124 and under	62.0	...	...	...
	0.125–6.500 <sup>H</sup>	62.0	...	50.0	5
T62 <sup>G</sup>	0.124 and under	60.0	...	...	...
	0.125–6.500 <sup>H</sup>	60.0	...	46.0	5
T851 <sup>E</sup>	0.500–6.500 <sup>H</sup>	66.0	...	58.0	5
<b>Alloy 2219</b>					
T851 <sup>E</sup>	0.500–2.000	58.0	...	40.0	4
	2.001–4.000	57.0	...	39.0	4
<b>Alloy 3003</b>					
O	all	14.0	19.0	5.0	25
H12	0.374 and under	17.0	...	...	...
H14	0.374 and under	20.0	...	...	...
H16	0.374 and under	24.0	...	...	...
H18	0.374 and under	27.0	...	...	...
H112	all	14.0	...	5.0	...
F	all	<sup>D</sup>	...	<sup>D</sup>	...
<b>Alloy 4032</b>					
T86	0.375–0.750	51.0	...	46.0	4
<b>Alloy 5052</b>					
O	0.124 and under	...	32.0	...	...
	0.125 and over	25.0	32.0	9.5	25
H32	0.124 and under	31.0	...	...	...
	0.125–0.374	31.0	...	23.0	...
H34	0.374 and under	34.0	...	26.0	...
H36	0.124 and under	37.0	...	...	...
	0.125–0.374	37.0	...	29.0	...
H38	0.374 and under	39.0	...	...	...
F	all	<sup>D</sup>	...	<sup>D</sup>	...

TABLE 2 Continued

Temper	Specified Diameter or Thickness, in.	Tensile Strength, ksi		Yield Strength <sup>B</sup> (0.2 % offset), min, ksi	Elongation <sup>B</sup> in 2 in. or 4× Diameter, min %
		min	max		
<b>Alloy 5056</b>					
O	0.124 and under	...	46.0	...	...
	0.125 and over	...	46.0	...	20
H111	0.374 and under	44.0	...	...	...
H12	0.374 and under	46.0	...	...	...
H32	0.374 and under	44.0	...	...	...
H14	0.374 and under	52.0	...	...	...
H34	0.374 and under	50.0	...	...	...
H18	0.374 and under	58.0	...	...	...
H38	0.374 and under	55.0	...	...	...
H192	0.374 and under	60.0	...	...	...
H392	0.374 and under	58.0	...	...	...
<b>Alloy 5154</b>					
O	all	30.0	41.0	11.0	25
H32	0.374 and under	36.0	...	...	...
H34	0.374 and under	39.0	...	...	...
H36	0.374 and under	42.0	...	...	...
H38	0.374 and under	45.0	...	...	...
H112	all	30.0	...	11.0	...
<b>Alloy 6013</b>					
T651 <sup>F</sup>	0.500–4.000	56.0	...	52.0	7
T8	0.750–1.500	58.0	...	56.0	8
	1.501–5.500	57.0	...	55.0	7
<b>Alloy 6020</b>					
T8	0.187–0.375	43.0	...	40.0	12
	0.376–1.999	42.0	...	39.0	12
	2.000–3.250	39.0	...	36.0	12
<b>Alloy 6026</b>					
T6	0.200–3.000	54.0	...	44.0	6
T8	0.200–3.000	50.0	...	46.0	3
T9	0.200–3.000	52.0	...	48.0	3
<b>Alloy 6061<sup>F</sup></b>					
O	0.124 and under	...	22.0	...	...
	0.125–8.000	...	22.0	...	18
T4 & T451 <sup>E</sup>	0.124 and under	30.0	...	...	...
	0.125–8.000 <sup>I</sup>	30.0	...	16.0	18
T42 <sup>G</sup>	0.125–8.000 <sup>I</sup>	30.0	...	14.0	18
T6, T62 <sup>G</sup> , & T651 <sup>E</sup>	0.124 and under	42.0	...	...	...
	0.125–8.000 <sup>I</sup>	42.0	...	35.0	10
T89 & T94	0.374 and under	54.0	...	47.0	...
<b>Alloy 6110</b>					
T9	0.374 and under	65.0	...	63.0	2
<b>Alloy 6262</b>					
T6 & T651 <sup>E</sup>	0.125–8.000 <sup>IJ</sup>	42.0	...	35.0	10
T8	0.750–2.000	45.0	...	43.0	12
T9	0.125–2.000	52.0	...	48.0	5
	2.001–3.000	50.0	...	46.0	5
<b>Alloy 7075<sup>F</sup></b>					
O	0.124 and under	...	40.0	...	...
	0.125–8.000	...	40.0	...	10
T6, T62 <sup>G</sup>	0.124 and under	77.0	...	66.0	...
	0.125–4.000 <sup>L</sup>	77.0	...	66.0	7
T651 <sup>E</sup>	0.124 and under	77.0	...	66.0	...
	0.125–4.000 <sup>L</sup>	77.0	...	66.0	7
	4.001–6.000	75.0	...	64.0	7
	6.001–7.000	73.0	...	62.0	7
T73 & T7351 <sup>E</sup>	0.124 and under	68.0	...	...	...
	0.125–4.000	68.0	...	56.0	10
	4.001–5.000	66.0	...	55.0	8
	5.001–6.000	64.0	...	52.0	8
<b>Alloy 2017</b>					
T4, T42, & T451	0.124 and under			3 <sup>M</sup>	
	0.125–8.000 <sup>I</sup>			6 <sup>M</sup>	
<b>Alloy 2024</b>					
O	0.124 and under			1	
T351, T4, T42	0.124 and under			3	
	0.125–6.500			6	
<b>Alloy 3003</b>					
O	all			0	
H12	0.374 and under			2	
H14	0.374 and under			2	
H16	0.374 and under			8	

<sup>A</sup> To determine conformance to this specification, each value for tensile strength and for yield strength shall be rounded to the nearest 0.1 ksi [1 MPa] and each value for elongation to the nearest 0.5 %, both in accordance with the rounding-off method of Practice E29. The basis for establishment of tensile property limits is shown in Annex A1.

<sup>B</sup> The measurement of yield strength and elongation is not required for wire less than 0.125 in. [3.20 mm] in thickness or diameter.

<sup>C</sup> Elongations in 50 mm applies to rectangular bar up through 12.5 mm thickness from which a standard rectangular tension test specimen is machined. The 5× diameter (5.65√A) requirements, where D and A are diameter and cross-sectional area of the specimen, respectively, apply to round specimens tested in full section or to standard or proportional, round-machined, tension test specimens.

<sup>D</sup> There are no tensile requirements for material in the F temper but it usually can be expected that material 1½ in. [40 mm] or less in thickness or diameter (except sections over 4 in. [100 mm] in width) will have a strength about equivalent to the H14 or H34 temper. As size increases the strength decreases to nearly that of the O temper.

<sup>E</sup> For stress-relieved tempers, characteristics and properties other than those specified may differ somewhat from the corresponding characteristics and properties of material in the basic tempers.

<sup>F</sup> Also available in the F temper for which no properties are specified or test results provided. Producers shall perform tension tests to confirm response to heat treatment as required by Section 10.

<sup>G</sup> Material in the T42 or T62 tempers is not available from the materials producers. These properties can usually be obtained by the user when material is properly solution heat treated or solution and precipitation heat treated from the O or F temper. These properties also apply to samples of material in the O or F temper that are solution heat treated or solution and precipitation heat treated by the producer to determine that the material will respond to proper heat treatment. Properties attained by the user, however, may be lower than those listed if the material has been formed or otherwise cold or hot worked, particularly in the O temper, prior to solution heat treatment.

<sup>H</sup> Properties listed for this full size increment are applicable to rod. Properties listed are also applicable to square, rectangular, hexagonal, or octagonal bar having a maximum thickness of 4 in. [100 mm] and a maximum cross-sectional area of 36 in.<sup>2</sup> [23 000 mm<sup>2</sup>].

<sup>I</sup> For bar, maximum cross-sectional area is 50 in.<sup>2</sup> [32 000 mm<sup>2</sup>].

<sup>J</sup> Minimum yield strength for 2024-T4 wire and rod 0.125 in. [3.20 mm] and larger in thickness or diameter, produced in coil form for both straight length and coiled products, is 40.0 ksi [275 MPa].

<sup>K</sup> Properties listed for this size increment are applicable to rod only.

<sup>L</sup> For rounds, maximum diameter is 4 in. [100 mm]; for square, hexagonal, or octagonal bar, maximum thickness is 3½ in. [90 mm]; for rectangular bar, maximum thickness is 3 in. [80 mm] with corresponding maximum width of 6 in. [150 mm]; for rectangular bar less than 3 in. [80 mm] in thickness, maximum width is 10 in. [250 mm].

<sup>M</sup> Bend diameter factor values stated for this full size increment apply to T4 product only. Values listed also apply to T451 product in the 0.500–8.000 in. [12.20–200 mm] size range.

3.2.1 *capable of*—The term *capable of* as used in this specification means that the test need not be performed by the producer of the material. However, should subsequent testing by the purchaser establish that the material does not meet these requirements, the material shall be subject to rejection.

#### 4. Ordering Information

4.1 Orders for material to this specification shall include the following information:

4.1.1 This specification designation (which includes the number, the year, and the revision letter, if applicable),

4.1.2 Quantity in pieces or pounds [kilograms],

4.1.3 Alloy (Section 7),

4.1.4 Temper (Section 9),

4.1.5 *Product Form*, rolled or cold finished bar, rolled or cold finished rod, or wire,

4.1.6 *Geometry and Dimensions*, Diameter for rounds; distance across flats for square-cornered squares, hexagons, or octagons; width and depth for square-cornered rectangles (orders for squares, hexagons, octagons, or rectangles with rounded corners usually require a drawing),

4.1.7 Length, and

4.1.8 Tensile property limits and dimensional tolerances for sized not covered in Table 2 [Table 3] and in ANSI H35.2 [H35.2M], respectively.

4.2 Additionally, orders for material to this specification shall include the following information when required by the purchaser:

4.2.1 Whether heat treatment in accordance with Practice B918/B918M is required (8.2),

4.2.2 Whether 7075-O material is required to develop requirements for T73 temper (see 10.1.2),

4.2.3 Whether bend testing is required for 2017, 2024, or 3003 (Section 12),

4.2.4 When specified finish of bar and rod is not required (Section 15),

4.2.5 Whether marking for identification is required (Section 16),

4.2.6 Whether ultrasonic inspection is required (Section 17, Table 5Table 5),

4.2.7 Whether inspection or witness of inspection and tests by the purchaser's representative is required prior to material shipment (Section 19),

4.2.8 DELETED

4.2.9 Whether Practices B660 apply, and if so, the levels of preservation, packaging, and packing required (Section 22).

#### 5. Manufacture

5.1 The products covered by this specification shall be produced either by hot extruding and cold finishing or by hot rolling with or without cold finishing, at the option of the producer.

#### 6. Quality Assurance

6.1 *Responsibility for Inspection and Tests*—Unless otherwise specified in the contract or purchase order, the producer is responsible for the performance of all inspection and test requirements specified herein. The producer may use their own or any other suitable facilities for the performance of the inspection and test requirements specified herein, unless disapproved by the purchaser in the order or at the time of contract signing. The purchaser shall have the right to perform any of the inspections and tests set forth in this specification where such inspections are deemed necessary to ensure that material conforms to prescribed requirements.

6.2 *Lot Definition*—An inspection lot shall be defined as follows:

6.2.1 For heat-treated tempers, an inspection lot shall consist of an identifiable quantity of material of the same mill form, alloy, temper, and nominal dimensions traceable to a heat-treat lot or lots, and subjected to inspection at one time.

**TABLE 3 Mechanical Property Limits (Metric SI)<sup>A</sup>**  
(See Table 2 for footnotes.)

Temper	Specified Diameter or Thickness, mm		Tensile Strength, MPa		Yield Strength <sup>B</sup> (0.2 % offset), MPa		Elongation, <sup>B,C</sup> min, %	
	over	through	min	max	min	max	in 50 mm	in 5x Diameter (5.65√A)
<b>Aluminum 1100</b>								
O	...	3.20	75	105	...	...	...	...
	3.20	...	75	105	20	...	25	22
H12	...	10.00	95	...	...	...	...	...
H14	...	10.00	110	...	...	...	...	...
H16	...	10.00	130	...	...	...	...	...
H18	...	10.00	150	...	...	...	...	...
H112	all		75	...	20	...	...	...
F	all		<sup>D</sup>	...	<sup>D</sup>	...	...	...
<b>Alloy 2011</b>								
T3	3.20	40.00	310	...	260	...	10	9
	40.00	50.00	295	...	235	...	...	10
	50.00	90.00	290	...	205	...	...	12
T4 and T451 <sup>E</sup>	3.20	200.00	275	...	125	...	16	14
T6 and T651	10.00	160.00	370	...	275	...	10	9
T8	3.20	80.00	370	...	275	...	10	9
<b>Alloy 2111</b>								
T8	12.70	88.90	360	...	260	...	...	9
<b>Alloy 2014<sup>F</sup></b>								
O	...	3.20	...	240	...	...	...	...
	3.20	200.00	...	240	...	...	12	10
T4, T42 <sup>G</sup> , & T451 <sup>E</sup>	...	3.20	380	...	...	...	...	...
	3.20	200.00 <sup>H</sup>	380	...	220	...	16	14
T6, T62 <sup>G</sup> , & T651 <sup>E</sup>	...	3.20	450	...	...	...	...	...
	3.20	200.00 <sup>H</sup>	450	...	380	...	8	7
<b>Alloy 2017<sup>F</sup></b>								
O	...	3.20	...	240	...	...	...	...
	3.20	200.00	...	240	...	...	16	14
T4, T42 <sup>G</sup> , & T451 <sup>E</sup>	...	3.20	380	...	...	...	...	...
	3.20	200.00 <sup>H,I</sup>	380	...	220	...	12	10
<b>Alloy 2024<sup>F</sup></b>								
O	...	3.20	...	240	...	...	...	...
	3.20	200.00	...	240	...	...	16	14
T36	...	3.20	475	...	...	...	...	...
	3.20	10.00	475	...	360	...	10	...
T4 <sup>J</sup>	...	3.20	425	...	...	...	...	...
	3.20	12.50	425	...	310 <sup>J</sup>	...	10	...
	12.50	120.00 <sup>H</sup>	425	...	290 <sup>J</sup>	...	...	9
	120.00	160.00 <sup>K</sup>	425	...	275	...	...	9
	160.00	200.00 <sup>K</sup>	425	...	260	...	...	9
T42 <sup>G</sup>	...	3.20	400	...	...	...	...	...
	3.20	25.00	425	...	275	...	10	9
	25.00	160.00 <sup>H</sup>	425	...	275	...	...	9
T351 <sup>E</sup>	12.50	160.00 <sup>H</sup>	425	...	310	...	...	9
	160.00	200.00	425	...	310	...	...	8
T6	...	3.20	425	...	...	...	...	...
	3.20	160.00 <sup>H</sup>	425	...	345	...	5	4
T62 <sup>G</sup>	...	3.20	415	...	...	...	...	...
	3.20	160.00 <sup>H</sup>	415	...	315	...	5	4
T851 <sup>E</sup>	12.50	160.00 <sup>H</sup>	455	...	400	...	...	4
<b>Alloy 2219</b>								
T851 <sup>E</sup>	12.50	50.00	400	...	275	...	...	3
	50.00	100.00	395	...	270	...	...	3
<b>Alloy 3003</b>								
O	...	3.20	95	130	...	...	...	...
	3.20	...	95	130	35	...	25	22
H12	...	10.00	115	...	...	...	...	...
H14	...	10.00	140	...	...	...	...	...
H16	...	10.00	165	...	...	...	...	...
H18	...	10.00	185	...	...	...	...	...
H112	all		95	...	35	...	...	...
F	all		<sup>D</sup>	...	<sup>D</sup>	...	...	...
<b>Alloy 4032</b>								
T86	10.00	20.00	350	...	315	...	4	3
<b>Alloy 5052</b>								
O	...	3.20	170	220	...	...	...	...
	3.20	...	170	220	65	...	25	22
H32	...	3.20	215	...	...	...	...	...
	3.20	10.00	215	...	160	...	...	...
H34	...	3.20	235	...	...	...	...	...
	3.20	10.00	235	...	180	...	...	...

TABLE 3 Continued

Temper	Specified Diameter or Thickness, mm		Tensile Strength, MPa		Yield Strength <sup>B</sup> (0.2 % offset), MPa		Elongation, <sup>B,C</sup> min, %	
	over	through	min	max	min	max	in 50 mm	in 5× Diameter (5.65√A)
<b>Alloy 5052 (Continued)</b>								
H36	...	3.20	255	...	...	...	...	...
	3.20	10.00	255	...	200	...	...	...
F	all		<i>D</i>	...	<i>D</i>	...	...	...
<b>Alloy 5056</b>								
O	...	3.20	...	320	...	...	...	...
	3.20	...	...	320	...	...	20	18
H111	...	10.00	300	...	...	...	...	...
H12	...	10.00	315	...	...	...	...	...
H32	...	10.00	300	...	...	...	...	...
H14	...	10.00	360	...	...	...	...	...
H34	...	10.00	345	...	...	...	...	...
H18	...	10.00	400	...	...	...	...	...
H38	...	10.00	380	...	...	...	...	...
H192	...	10.00	415	...	...	...	...	...
H392	...	10.00	400	...	...	...	...	...
<b>Alloy 5154</b>								
O	...	3.20	205	285	...	...	...	...
	3.20	...	205	285	75	...	25	22
H32	...	10.00	250	...	...	...	...	...
H34	...	10.00	270	...	...	...	...	...
H36	...	10.00	290	...	...	...	...	...
H38	...	10.00	310	...	...	...	...	...
H112	all		205	...	75	...	...	...
<b>Alloy 6013</b>								
T651 <sup>E</sup>	12.50	100.00	385	...	360	...	...	6
T8	20.00	40.00	400	...	385	...	...	7
	40.00	140.00	395	...	380	...	...	6
<b>Alloy 6020</b>								
T8	5.00	10.00	295	...	275	...	12	...
	10.00	50.00	290	...	270	...	12	10
	50.00	80.00	270	...	250	...	...	10
<b>Alloy 6026</b>								
T6	5.00	80.00	370	...	300	...	6	8
T8	5.00	80.00	345	...	315	...	3	4
T9	5.00	80.00	360	...	330	...	3	4
<b>Alloy 6061<sup>F</sup></b>								
O	...	3.20	...	155	...	...	...	...
	3.20	200.00	...	155	...	...	18	16
T4 & T451 <sup>E</sup>	...	3.20	205	...	...	...	...	...
	3.20	200.00 <sup>I</sup>	205	...	110	...	18	16
T42 <sup>G</sup>	3.20	200.00 <sup>I</sup>	205	...	95	...	18	16
T6, T62 <sup>G</sup> , & T651 <sup>E</sup>	...	3.20	290	...	...	...	...	...
	3.20	200.00 <sup>I</sup>	290	...	240	...	10	9
T89 and T94	...	10.00	370	...	325	...	...	...
<b>Alloy 6110</b>								
T9	...	10.00	450	...	435	...	2	...
<b>Alloy 6262</b>								
T6 and T651 <sup>E</sup>	3.20	200.00 <sup>H</sup>	290	...	240	...	10	9
T8	20.00	50.00	310	...	295	...	12	10
T9	3.20	50.00	360	...	330	...	5	4
	50.00	80.00	345	...	315	...	...	4
<b>Alloy 7075<sup>F</sup></b>								
O	...	3.20	...	275	...	...	...	...
	3.20	200.00	...	275	...	...	10	9
T6, T62 <sup>G</sup>	...	3.20	530	...	455	...	...	...
	3.20	100.00 <sup>L</sup>	530	...	455	...	7	6
T651 <sup>E</sup>	...	3.20	530	...	455	...	...	...
	3.20	100.00 <sup>L</sup>	530	...	455	...	7	...
	100.00	160.00	515	...	440	...	7	...
	160.00	200.00	505	...	425	...	7	...
T73 and T7351 <sup>E</sup>	...	3.20	470	...	...	...	...	...
	3.20	100.00	470	...	425	...	10	9
	100.00	120.00	455	...	380	...	8	9
	120.00	160.00	440	...	360	...	...	7

Temper	Specified Diameter or Thickness, mm		Bend Diameter Factor, N
	over	through	
T4, T42, and T451	...	3.20	3 <sup>M</sup>
	3.20	200.00 <sup>l</sup>	6 <sup>M</sup>
<b>Alloy 2024</b>			
O	...	3.20	1
T351, T4, and T42	...	3.20	3
	3.20	160.00	6
<b>Alloy 3003</b>			
O	all		0
H12	...	10.00	2
H14	...	10.00	2
H16	...	10.00	8

(See Table 2 for footnotes.)

**TABLE 4 Lot Acceptance Criteria for Resistance to Stress Corrosion**

Alloy and Temper	Lot Acceptance Criteria		Lot Acceptance Status
	Electrical Conductivity, <sup>A</sup> % IACS	Level of Mechanical Properties	
7075-T73 and T7351	40.0 or greater	per specified requirements	acceptable
	38.0 through 39.9	per specified requirements and yield strength does not exceed minimum by more than 11.9 ksi [82 MPa]	acceptable
	38.0 through 39.9	per specified requirements but yield strength exceeds minimum by 12.0 ksi [82 MPa] or more	unacceptable <sup>B</sup>
	less than 38.0	any level	unacceptable <sup>B</sup>
Product <sup>A,B</sup>	Thickness, in. [Thickness, mm]	Location	
Rolled or cold finished from rolled stock	all	surface of tension-test sample	
Cold finished from extruded stock	up through 0.100 [up through 2.50 mm]	surface of tension-test sample	
	over 0.100 through 0.500 [over 2.50 through 12.50 mm]	subsurface after removing approximately 10 % of the thickness by machining	
	over 0.500 through 1.500 [over 12.50 through 40.00 mm]	subsurface at approximate center of thickness on a plane parallel to the longitudinal centerline of the material	
	over 1.500 [over 40.00 mm]	subsurface of tension-test sample surface that is closest to the center of the material and on a plane parallel to the extrusion surface	

<sup>A</sup> The electrical conductivity shall be determined in accordance with Practice E1004 in the following locations:

<sup>B</sup> When material is found to be unacceptable, it shall be reprocessed (additional precipitation heat treatment or re-solution heat treatment, stress relieving and precipitation heat treatment, when applicable).

**TABLE 5 Ultrasonic Discontinuity Limits for Rolled or Cold-Finished Bar<sup>A</sup>**

Alloys	Thickness, in. [Thickness, mm]	Maximum Weight per Piece, lb [kg]	Size		Discontinuity Class <sup>B</sup>
			Maximum Width to Thickness Ratio		
2014, 2219, 2024, 7075	0.500–1.499 [12.50–35.00 mm]	600 [300 kg]	...		B
	1.500–3.000 [35.00–80.00 mm]	600 [300 kg]	...		A
	3.001–6.000 [80.00–155.00 mm]	1000 [500 kg]	...		B

<sup>A</sup> Discontinuities in excess of those listed in this table shall be allowed if it is established that they will be removed by machining or that they are in noncritical areas.

<sup>B</sup> The discontinuity class limits are defined in Section 11 of Practice B594.

6.2.2 For nonheat-treated tempers, an inspection lot shall consist of an identifiable quantity of material of the same mill form, alloy, temper, and nominal dimensions subjected to inspection at one time.

## 7. Chemical Composition

7.1 *Limits*—The bars, rods, and wire shall conform to the chemical composition limits specified in Table 1. Conformance shall be determined by the producer by taking samples in accordance with E716 when the ingots are poured and analyzing those samples in accordance with E607, E1251, E3061, or CEN EN 14242. At least one sample shall be taken for each group of ingots poured simultaneously from the same source of molten metal. If the producer has determined the chemical composition of the material during pouring of the ingots, they shall not be required to sample and analyze the product.

NOTE 4—It is standard practice in the United States aluminum industry to determine conformance to the chemical composition limits prior to further processing of ingots into wrought products. Due to the continuous nature of the process, it is not practical to keep a specific ingot analysis identified with a specific quantity of finished material.

7.2 If it becomes necessary to analyze bars, rod or wire for conformance to chemical composition limits, the method used to sample for the determination of chemical composition shall be by agreement between the producer and the purchaser. Analysis shall be performed in accordance with Practices E716, Test Methods E607, E1251, or E3061, or CEN EN 14242 (ICP method). The number of samples taken for determination of chemical composition shall be as follows:

7.2.1 *Methods of Sampling*—Samples for chemical analysis shall be taken in accordance with Practice B985.

7.2.2 *Methods of Analysis*—Analysis shall be performed in accordance with Test Methods E607, E1251, E3061, or CEN EN 14242 (ICP Method).

7.3 Other methods of analysis or in the case of dispute may be by agreement between the producer and the purchaser.

NOTE 5—It is difficult to obtain a reliable analysis of each of the components of clad materials using material in its finished state. A reasonably accurate determination of the core composition can be made if the cladding is substantially removed prior to analysis. The cladding composition is more difficult to determine because of the relatively thin layer and because of diffusion of core elements to the cladding. The correctness of cladding alloy used can usually be verified by a combination of metallographic examination and spectrochemical analysis of the surface at several widely separated points.

## 8. Heat Treatment

8.1 Unless otherwise specified in 8.2, producer or supplier heat treatment for the applicable tempers in Table 2 [Table 3] shall be in accordance with AMS 2772.

8.2 When specified, heat treatment of applicable tempers in Table 2 [Table 3] shall be in accordance with Practice B918/B918M.

## 9. Tensile Properties of Material As Supplied

9.1 *Limits*—The bar, rod, and wire shall conform to the tensile requirements in Table 2 [Table 3].

9.2 *Number of Specimens*:

9.2.1 For material having a nominal weight of less than 1 lb/linear ft [up through 1.7 kg/linear meter], one tension test specimen shall be taken for each 1000 lb [500 kg] or fraction thereof in the lot. Only one specimen shall be taken from any one piece when more than one piece is available.

9.2.2 For material having a nominal weight of 1 lb or more/linear ft [over 1.7 kg/linear meter], one tension test specimen shall be taken for each 1000 ft [300 m] or fraction thereof in the lot. Only one specimen shall be taken from any one piece when more than one piece is available.

9.3 *Test Specimens*—Geometry of test specimens and the location in the product from which they are taken shall be as specified in Test Methods B557 [B557M].

9.4 *Test Methods*—The tension tests shall be made in accordance with Test Method B557 [B557M].

## 10. Producer Confirmation of Heat-Treat Response

10.1 In addition to the requirements of 9.1, material in Alloys 2014, 2017, 2024, and 6061 produced in the O or F temper (within the size limits specified in Table 2 [Table 3]) shall, after proper solution heat treatment and natural aging for not less than four days at room temperature, conform to the properties specified in Table 2 [Table 3] for T42 temper material. The heat-treated samples may be tested prior to four days natural aging, but if they fail to conform to the T42 temper properties, the tests may be repeated after completion of four days natural aging without prejudice.

10.1.1 Alloy 7075 material produced in the O or F temper (within the size limits specified in Table 2 [Table 3]) shall, after proper solution heat treatment and precipitation heat treatment, conform to the properties specified in Table 2 [Table 3] for T62 temper material.

10.1.2 When specified, 7075-O material (within the size limits specified in Table 2 [Table 3]) shall, after proper solution and precipitation heat treatment, conform to the properties specified for T73 temper in Table 2 [Table 3] and Section 13.

10.2 *Number of Specimens*—The number of specimens from each lot of O temper material and F temper material to verify conformance with 10.1 shall be as specified in 9.2.

## 11. Heat Treatment and Reheat Treatment Capability

11.1 As-received material in the O or F temper and in Alloys 2014, 2017, 2024, and 6061 (within the size limitation specified in Table 2 [Table 3] and without the imposition of cold work) shall, after proper solution heat treatment and natural aging for not less than four days at room temperature, conform to the properties specified in Table 2 [Table 3] for T42 temper material.

11.2 As-received Alloy 7075 material in the O or F temper (within the size limitation specified in Table 2 [Table 3] and without the imposition of cold work) shall, after proper solution and precipitation heat treatment, conform to the properties specified in Table 2 [Table 3] for T6 and T62 tempers.

11.3 Material in Alloys and Tempers 2014-T4, T451, T6, T651; 2017-T4, T451; 2024-T4, T6, T351, and T851, shall,

after proper resolution heat treatment and natural aging for not less than four days at room temperature, conform to the properties specified in Table 2 [Table 3] for the T42 temper.

NOTE 6—Beginning with the 1975 revision, 6061-T4, T6, T451, and T651 were deleted from this paragraph because experience has shown the reheat-treated material tends to develop large recrystallized grains and may fail to develop the expected level of properties.

11.4 Alloy 7075 material in T6, T651, T73, and T7351 tempers shall, after proper resolution heat treatment and precipitation heat treatment, conform to the properties specified in Table 2 [Table 3] for T6 and T62 tempers.

11.5 Material in T3, T4, T42, T351, and T451 tempers shall, after proper precipitation heat treatment, conform to the properties specified in Table 2 [Table 3] for the T8, T6, T62, T851 and T651 tempers, respectively.

## 12. Bend Properties

12.1 When bend testing is specified for the alloys, tempers, and dimensions as listed with Bend Diameter Factor, N, values in Table 2 [Table 3]; bend test specimens shall be prepared and tests shall be made in accordance with the applicable requirements of Test Method E290. Bend test samples shall be bent cold without cracking through an angle of 180° around a pin having a diameter equal to N times the product diameter or least thickness of the specimen.

## 13. Stress-Corrosion Resistance

13.1 Alloy 7075 in the T73-type tempers shall be capable of exhibiting no evidence of stress-corrosion cracking when subjected to the test specified in 13.2.

13.1.1 For lot-acceptance purposes, resistance to stress-corrosion cracking for each lot of material shall be established by testing the previously selected tension-test samples to the criteria shown in Table 4.

13.1.2 For surveillance purposes, each month the producer shall perform at least one test for stress-corrosion resistance in accordance with 13.2 in the T73 type temper, for each thickness range 0.750 in. [20.00 mm] and over listed in Table 2 [Table 3], produced that month. Each sample shall be taken from material considered acceptable in accordance with lot-acceptance criteria of Table 4. A minimum of three adjacent replicate specimens shall be taken from each sample and tested. The producer shall maintain records of all lots so tested and make them available for examination at the producer's facility.

13.2 The stress-corrosion cracking test shall be performed on material 0.750 in. [20.00 mm] and over in thickness as follows:

13.2.1 Specimens shall be stressed in tension in the short transverse direction with respect to grain flow and held at constant strain. The stress level shall be 75 % of the specified minimum yield strength.

13.2.2 The stress-corrosion test shall be made in accordance with Test Method G47.

13.2.3 There shall be no visual evidence of stress-corrosion cracking in any specimen, except that the retest provisions of 20.2 shall apply.

## 14. Dimensional Tolerances

14.1 Material ordered to this specification shall meet the applicable dimensional requirements of ANSI H35.2 [H35.2M].

14.2 *Sampling for Inspection*—Examination for dimensional conformance shall be made to ensure conformance to the tolerance specified.

## 15. Finish

15.1 Unless otherwise specified, rod up to and including 3 in. in diameter and bar up to and including 2 in. thick (with maximum width for rectangles of 4 in.) shall be supplied cold finished. Rod and bar in larger sizes may be furnished either as rolled or cold finished, at the producer's or supplier's discretion.

## 16. Identification Marking of Product

16.1 When specified in the contract or purchase order, all material shall be marked in accordance with Practice B666/B666M.

## 17. Internal Quality

17.1 When specified by the purchaser at the time of placing the order, each bar 0.500 in. or greater in thickness or smallest dimension in Alloys 2014, 2024, 2219, and 7075 shall be tested in accordance with Practice B594 to the discontinuity acceptance limits of Table 5.

## 18. General Quality

18.1 Unless otherwise specified, the material shall be supplied in the mill finish and shall be uniform as defined by the requirements of this specification and shall be commercially sound. Any requirement not so covered is subject to negotiation between the producer and the purchaser.

18.2 Each inspection lot of bar, rod, and wire shall be examined to determine conformance to this specification with respect to general quality and identification marking. On approval of the purchaser, however, the producer may use a system of statistical quality control for such examinations.

## 19. Source Inspection

19.1 If the purchaser desires that his representative inspect or witness the inspection and testing of the material prior to shipment, such agreement shall be made by the purchaser and producer as part of the purchase contract.

19.2 When such inspection or witness of inspection and testing is agreed upon, the producer shall afford the purchaser's representative all reasonable facilities to satisfy him that the material meets the requirements of this specification. Inspection and tests shall be conducted so there is no unnecessary interference with the producer's operations.

## 20. Rejection and Retest

20.1 If any material fails to conform to all of the applicable requirements of this specification, it shall be cause for rejection of the inspection lot.

20.2 When there is evidence that a failed specimen was not representative of the inspection lot and when no other sampling plan is provided or approved by the purchaser through the contract or purchase order, at least two additional specimens shall be selected to replace each test specimen that failed. All specimens so selected for re-test shall meet the requirements of the specification or the lot shall be subject to rejection.

20.3 Material in which defects are discovered subsequent to inspection may be rejected.

20.4 If material is rejected by the purchaser, the producer or supplier is responsible only for replacement of the material to the purchaser. As much as possible of the rejected material shall be returned to the producer or supplier.

## 21. Certification and Test Report

21.1 The producer or supplier shall furnish to the purchaser a certificate of inspection stating that each lot has been sampled, tested, and inspected in accordance with this specification, and has been found to meet the requirements. In addition, all test reports required by this specification shall be supplied with the certification.

## 22. Packaging and Package Marking

22.1 The material shall be packaged to provide adequate protection during normal handling and transportation and each

package shall contain only one size, alloy, and temper of material unless otherwise agreed. The type of packing and gross weight of containers shall, unless otherwise agreed upon, be at the producer's discretion, provided that they are such as to ensure acceptance by common or other carriers for safe transportation at the lowest rate to the delivery point.

22.2 Each shipping container shall be marked with the purchase order number, material size, specification number, alloy and temper, gross and net weight, and the producer's name and trademark.

22.3 When specified in the contract or purchase order, material shall be preserved, packaged, and packed in accordance with the requirements of Practice B660. The applicable levels shall be as specified in the contract or order. Marking for shipment of such material shall be in accordance with Fed. Std. No. 123 for civil agencies and MIL-STD-129 for military agencies.

## 23. Keywords

23.1 aluminum alloy; rolled or cold-finished bar; rolled or cold-finished rod; rolled or cold-finished wire

## ANNEXES

### (Mandatory Information)

#### A1. BASIS FOR INCLUSION OF PROPERTY LIMITS

A1.1 Mechanical property limits are established in accordance with section 6, Standards Section, of the most current edition of the Aluminum Standards and Data and the latest edition of the Aluminum Association publication "Tempers for Aluminum and Aluminum Alloy Products (Yellow and Tan Sheets)".

Limits are based on a statistical evaluation of the data indicating that at least 99 % of the population obtained from all standard material meets the limit with 95 % confidence. For the products described, mechanical property limits are based on the statistical analyses of at least 100 tests from at least five cast lots of standard production material with no more than ten observations from a given heat treat or inspection lot. Mechanical properties limits for press solution heat treated products have specific additional requirements which are provided in the "Tempers for Aluminum and Aluminum Alloy Products".

Limits denoted as "Tentative" by the Aluminum Association may be included. Requirements for tentative property registrations are defined in the latest edition of the Aluminum Association publication "Tempers for Aluminum and Aluminum Alloy Products". Tentative property limits are established at levels at which at least 99 % of the data conform at a confidence level of 95 %.

Tentative property limits, which are subject to revision, shall be based on a statistical analysis of at least 30 tests from at least three cast lots of standard production material with no more than ten observations from a given heat treat or inspection lot. Where tentative property limits are listed, they shall be shown in italics and footnoted as Tentative in the standard.

All tests are performed in accordance with the appropriate ASTM test methods.

## A2. ACCEPTANCE CRITERIA FOR INCLUSION OF NEW ALUMINUM AND ALUMINUM ALLOYS IN THIS SPECIFICATION

A2.1 Prior to acceptance for inclusion in this specification, the composition of wrought or cast aluminum or aluminum alloy shall be registered in accordance with ANSI H35.1/H35.1M. The Aluminum Association holds the Secretariat of ANSI H35 Committee and administers the criteria and procedures for registration.

A2.2 If it is documented that the Aluminum Association could not or would not register a given composition, an alternative procedure and the criteria for acceptance shall be as follows:

A2.2.1 The designation submitted for inclusion does not utilize the same designation system as described in ANSI H35.1/H35.1M. A designation not in conflict with other designation systems or a trade name is acceptable.

A2.2.2 The aluminum or aluminum alloy has been offered for sale in commercial quantities within the prior twelve months to at least three identifiable users.

A2.2.3 The complete chemical composition limits are submitted.

A2.2.4 The composition is, in the judgment of the responsible subcommittee, significantly different from that of any other aluminum or aluminum alloy already in the specification.

A2.2.5 For codification purposes, an alloying element is any element intentionally added for any purpose other than grain

refinement and for which minimum and maximum limits are specified. Unalloyed aluminum contains a minimum of 99.00 % aluminum.

A2.2.6 Standard limits for alloying elements and impurities are expressed to the following decimal places:

Less than 0.001 %	0.000X
0.001 to but less than 0.01 %	0.00X
0.01 to but less than 0.10 %	
Unalloyed aluminum made by a refining process	0.0XX
Alloys and unalloyed aluminum not made by a refining process	0.0X
0.10 through 0.55 %	0.XX
(It is customary to express limits of 0.30 through 0.55 % as 0.X0 or 0.X5)	
Over 0.55 %	0.X, X.X, etc.
(except that combined Si + Fe limits for 99.00 % minimum aluminum must be expressed as 0.XX or 1.XX)	

A2.2.7 Standard limits for alloying elements and impurities are expressed in the following sequence: Silicon; Iron; Copper; Manganese; Magnesium; Chromium; Nickel; Zinc; Titanium (Note A2.1); Other Elements, Each; Other Elements, Total; Aluminum (Note A2.2).

NOTE A2.1—Additional specified elements having limits are inserted in alphabetical order of their chemical symbols between zinc and titanium, or are specified in footnotes.

NOTE A2.2—Aluminum is specified as *minimum* for unalloyed aluminum and as a *remainder* for aluminum alloys.

ASMENORMDOC.COM : Click to view the full PDF of ASME BPVC.II.B (ASME BPVC Section II part B) 2025

INTENTIONALLY LEFT BLANK

# SPECIFICATION FOR ALUMINUM AND ALUMINUM-ALLOY EXTRUDED BARS, RODS, WIRE, PROFILES, AND TUBES



**SB-221**



(25)

(Identical with ASTM Specification B221-21 except para. 1.1 has been revised to forbid the use of pipe, tube, and any hollow profile in pressure-retaining applications, and certification and test reports have been made mandatory.)

*ASME SB-221 replaces para. 1.1 and related Note 3, para. 4.2.5, and para. 22.1 of ASTM B221 with the following:*

1.1 This specification<sup>2</sup> covers aluminum and aluminum-alloy extruded bars, rods, wires, profiles, and tubes in the aluminum alloys (Note 1) and tempers shown in Table 2. Pipe, tube, and any hollow profile produced in accordance with Specification B221 shall not be used in pressure-retaining applications.

NOTE 3 — Pipe and tube products listed in this specification are intended for general purpose applications. See Specification B210/B210M, B241/B241M, or both as appropriate for seamless pipe and tube used in fluid-carrying applications involving pressure. See Specification B234M, as appropriate, for use in surface condensers, evaporators, and heat exchangers.

4.2.5 DELETED

22.1 The producer or supplier shall furnish to the purchaser a certificate stating that each lot has been sampled, tested, and inspected in accordance with this specification and has met the requirements. A report of test results shall be furnished.



Designation: B221 – 21

## Standard Specification for Aluminum and Aluminum-Alloy Extruded Bars, Rods, Wire, Profiles, and Tubes<sup>1</sup>

This standard is issued under the fixed designation B221; the number immediately following the designation indicates the year of original adoption or, in the case of revision, the year of last revision. A number in parentheses indicates the year of last reapproval. A superscript epsilon ( $\epsilon$ ) indicates an editorial change since the last revision or reapproval.

*This standard has been approved for use by agencies of the U.S. Department of Defense.*

### 1. Scope\*

1.1 This specification<sup>2</sup> covers aluminum and aluminum-alloy extruded bars, rods, wire, profiles, and tubes in the aluminum alloys (Note 1) and tempers shown in Table 2.

NOTE 1—Throughout this specification, the use of the term *alloy* in the general sense includes aluminum as well as aluminum alloy.

NOTE 2—For rolled or cold-finished bar and rod refer to Specification B211/B211M, for drawn seamless tube used in pressure applications, Specification B210/B210M, for structural pipe and tube, Specification B429/B429M, and for seamless pipe and tube used in pressure applications, Specification B241/B241M.

NOTE 3—Pipe and tube products listed in this specification are intended for general purpose applications. This specification may not address the manufacturing processes, integrity testing, and verification required for fluid-carrying applications involving pressure. See Specifications B210/B210M or B241/B241M, or both as appropriate, for seamless pipe and tube used in fluid-carrying applications involving pressure. See Specification B234, as appropriate, for use in surface condensers, evaporators, and heat exchangers.

1.2 Alloy and temper designations are in accordance with ANSI H35.1/H35.1M. The equivalent Unified Numbering System alloy designations are those of Table 1 preceded by A9; for example, A91100 for Aluminum 1100 in accordance with Practice E527.

1.3 For acceptance criteria for inclusion of new aluminum and aluminum alloys in this specification, see Annex A2.

1.4 A complete metric companion to Specification B221 has been developed—Specification B221M; therefore, no metric equivalents are presented in this specification.

1.5 *This international standard was developed in accordance with internationally recognized principles on standardization established in the Decision on Principles for the Development of International Standards, Guides and Recom-*

*mendations issued by the World Trade Organization Technical Barriers to Trade (TBT) Committee.*

### 2. Referenced Documents

2.1 The following documents of the issue in effect on the date of material purchase, unless otherwise noted, form a part of this specification to the extent referenced herein:

2.2 *ASTM Standards*:<sup>3</sup>

- B210/B210M Specification for Aluminum and Aluminum-Alloy Drawn Seamless Tubes
- B211/B211M Specification for Aluminum and Aluminum-Alloy Rolled or Cold Finished Bar, Rod, and Wire
- B234 Specification for Aluminum and Aluminum-Alloy Drawn Seamless Tubes for Surface Condensers, Evaporators, and Heat Exchangers
- B241/B241M Specification for Aluminum and Aluminum-Alloy Seamless Pipe and Seamless Extruded Tube
- B429/B429M Specification for Aluminum-Alloy Extruded Structural Pipe and Tube
- B557 Test Methods for Tension Testing Wrought and Cast Aluminum- and Magnesium-Alloy Products
- B594 Practice for Ultrasonic Inspection of Aluminum-Alloy Wrought Products
- B660 Practices for Packaging/Packing of Aluminum and Magnesium Products
- B666/B666M Practice for Identification Marking of Aluminum and Magnesium Products
- B807/B807M Practice for Extrusion Press Solution Heat Treatment for Aluminum Alloys
- B881 Terminology Relating to Aluminum- and Magnesium-Alloy Products
- B918/B918M Practice for Heat Treatment of Wrought Aluminum Alloys
- B945 Practice for Aluminum Alloy Extrusions Press Cooled from an Elevated Temperature Shaping Process for Production of T1, T2, T5 and T10-Type Tempers

<sup>1</sup> This specification is under the jurisdiction of ASTM Committee B07 on Light Metals and Alloys and is the direct responsibility of Subcommittee B07.03 on Aluminum Alloy Wrought Products.

Current edition approved Sept. 1, 2021. Published November 2021. Originally approved in 1947. Last previous edition approved in 2020 as B221 – 20. DOI: 10.1520/B0221-21.

<sup>2</sup> For ASME Boiler and Pressure Vessel Code applications see related Specification SB-221 in Section II of this Code.

<sup>3</sup> For referenced ASTM standards, visit the ASTM website, [www.astm.org](http://www.astm.org), or contact ASTM Customer Service at [service@astm.org](mailto:service@astm.org). For *Annual Book of ASTM Standards* volume information, refer to the standard's Document Summary page on the ASTM website.

- B985 Practice for Sampling Aluminum Ingots, Billets, Castings and Finished or Semi-Finished Wrought Aluminum Products for Compositional Analysis
- E29 Practice for Using Significant Digits in Test Data to Determine Conformance with Specifications
- E527 Practice for Numbering Metals and Alloys in the Unified Numbering System (UNS)
- E716 Practices for Sampling and Sample Preparation of Aluminum and Aluminum Alloys for Determination of Chemical Composition by Spark Atomic Emission Spectrometry
- E1004 Test Method for Determining Electrical Conductivity Using the Electromagnetic (Eddy Current) Method
- E1251 Test Method for Analysis of Aluminum and Aluminum Alloys by Spark Atomic Emission Spectrometry
- E3061 Test Method for Analysis of Aluminum and Aluminum Alloys by Inductively Coupled Plasma Atomic Emission Spectrometry (Performance Based Method)
- G34 Test Method for Exfoliation Corrosion Susceptibility in 2XXX and 7XXX Series Aluminum Alloys (EXCO Test)
- G47 Test Method for Determining Susceptibility to Stress-Corrosion Cracking of 2XXX and 7XXX Aluminum Alloy Products
- 2.3 *ANSI Standards:*<sup>4</sup>
- ANSI H35.1/H35.1M Alloy and Temper Designation Systems for Aluminum
- ANSI H35.2 Dimensional Tolerances For Aluminum Mill Products
- 2.4 *Federal Standard:*<sup>5</sup>
- FED-STD-123 Marking for Shipment (Civil Agencies)
- 2.5 *Military Standard:*<sup>5</sup>
- MIL-STD-129 Military Marking for Shipment and Storage
- 2.6 *AMS Specification:*<sup>6</sup>
- AMS 2772 Heat Treatment of Aluminum Alloy Raw Materials
- 2.7 *CEN Standard:*<sup>7</sup>
- CEN EN 14242 Aluminium and aluminium alloys - Chemical analysis - Inductively coupled plasma optical emission spectral analysis

### 3. Terminology

#### 3.1 Definitions:

3.1.1 Refer to Terminology B881 for definitions of product terms used in this specification.

#### 3.2 Definitions of Terms Specific to This Standard:

3.2.1 *capable of*—(as used in this specification) means that the test need not be performed by the producer of the material. However, should subsequent testing by the purchaser establish that the material does not meet these requirements, the material shall be subject to rejection.

<sup>4</sup> Available from Aluminum Association, 1400 Crystal Dr., Suite 430, Arlington, VA 22202, <http://www.aluminum.org>.

<sup>5</sup> Available from DLA Document Services, Building 4/D, 700 Robbins Ave., Philadelphia, PA 19111-5094, <http://quicksearch.dla.mil>.

<sup>6</sup> Available from SAE International (SAE), 400 Commonwealth Dr., Warrendale, PA 15096, <http://www.sae.org>.

<sup>7</sup> Available from European Committee for Standardization (CEN), Avenue Marnix 17, B-1000, Brussels, Belgium, <http://www.cen.eu>.

### 4. Ordering Information

4.1 Orders for material to this specification shall include the following information:

4.1.1 This specification designation (which includes the number, the year, and the revision letter, if applicable).

4.1.2 Quantity in pieces or pounds.

4.1.3 Alloy (Section 7 and Table 1).

NOTE 4—In the case of a discrepancy in the values listed in Table 1 with those listed in the “International Alloy Designations and Chemical Composition Limits for Wrought Aluminum and Wrought Aluminum Alloys” (known as the “Teal Sheets”), the composition limits registered with the Aluminum Association and published in the “Teal Sheets” should be considered the controlling composition. The “Teal Sheets” are available at <http://www.aluminum.org/tealsheets>.

4.1.4 Temper (Section 8 and Table 2).

4.1.5 Nominal cross-sectional dimensions as follows:

4.1.5.1 For rod and round wire: diameter.

4.1.5.2 For square-cornered bar and wire: depth and width.

4.1.5.3 For sharp-cornered hexagonal or octagonal bar and wire: distance across flats.

4.1.5.4 For round tube: outside or inside diameter and wall thickness.

4.1.5.5 For square or sharp-cornered tube other than round: distance across flats and wall thickness.

4.1.5.6 For round-cornered bars, profiles, tube other than round, square, rectangular, hexagonal, or octagonal with sharp corners: drawing required.

4.1.6 Length.

4.2 Additionally, orders for material to this specification shall include the following information when required by the purchaser:

NOTE 5—For heat-treatable alloys, the default standard to follow for producing T3, T4, T6, T7, T8 and T9 tempers is AMS 2772. However, in the case of most 6XXX and some 7XXX alloys (see 9.2 for list of alloys), the producer may choose to solution heat treat the product at the press in accordance with Practice B807/B807M, as long as the purchaser does not specifically object to this practice in the purchasing agreement. Alternatively, heat treatment may be accomplished in accordance with Practice B918/B918M instead of either of the previous options.

It is up to the purchaser to specify in the purchasing agreement if solution heat treatment at the press is not allowed and/or if heat treatment in accordance with Practice B918/B918M is preferred. If the purchaser does not specify a preference for a heat treatment practice, Practice B807/B807M may be used for any alloy listed in 9.2, and AMS 2772 shall be the practice used for any other heat-treatable alloy.

4.2.1 Whether solution heat treatment at the press in accordance with Practice B807/B807M is unacceptable (9.2).

4.2.2 Whether heat treatment in accordance with Practice B918/B918M is preferred to the default practice, AMS 2772 (9.3).

4.2.3 Whether ultrasonic inspection is required (Section 17, Table 3).

4.2.4 Whether inspection or witness of inspection and tests by the purchaser’s representative is required prior to material shipment (Section 18).

4.2.5 Whether certification is required (Section 22).

4.2.6 Whether marking for identification is required in accordance with Practice B666/B666M, Section 20.

4.2.7 Whether Practice B660 applies and, if so, the levels of preservation, packaging, and packing required (21.3).

TABLE 1 Chemical Composition Limits<sup>A,B,C</sup>

Alloy	Si	Fe	Cu	Mn	Mg	Cr	Zn	Ti	V	Other Elements <sup>D</sup>		Al
										Each	Total <sup>E</sup>	
1060	0.25	0.35	0.05	0.03	0.03	...	0.05	0.03	0.05	0.03	...	99.60 min <sup>F</sup>
1100 <sup>G</sup>	0.95 Si + Fe		0.05-0.20	0.05	...	...	0.10	...	...	0.05	0.15	99.00 min <sup>F</sup>
2014 <sup>H</sup>	0.50-1.2	0.7	3.9-5.0	0.40-1.2	0.20-0.8	0.10	0.25	0.15	...	0.05	0.15	rem
2024 <sup>H</sup>	0.50	0.50	3.8-4.9	0.30-0.9	1.2-1.8	0.10	0.25	0.15	...	0.05	0.15	rem
2219 <sup>I</sup>	0.20	0.30	5.8-6.8	0.20-0.40	0.02	...	0.10	0.02-0.10	0.05-0.15	0.05	0.15	rem
3003	0.6	0.7	0.05-0.20	1.0-1.5	...	...	0.10	...	...	0.05	0.15	rem
Alclad 3003	...	3003 Clad with 7072 alloy		...	...	...	...	...	...	...	...	rem
3004	0.30	0.7	0.25	1.0-1.5	0.8-1.3	...	0.25	...	...	0.05	0.15	rem
3102	0.40	0.7	0.10	0.05-0.40	...	...	0.30	0.10	...	0.05	0.15	rem
5052	0.25	0.40	0.10	0.10	2.2-2.8	0.15-0.35	0.10	...	...	0.05	0.15	rem
5083	0.40	0.40	0.10	0.40-1.0	4.0-4.9	0.05-0.25	0.25	0.15	...	0.05	0.15	rem
5086	0.40	0.50	0.10	0.20-0.7	3.5-4.5	0.05-0.25	0.25	0.15	...	0.05	0.15	rem
5154 <sup>G</sup>	0.25	0.40	0.10	0.10	3.1-3.9	0.15-0.35	0.20	0.20	...	0.05	0.15	rem
5454	0.25	0.40	0.10	0.50-1.0	2.4-3.0	0.05-0.20	0.25	0.20	...	0.05	0.15	rem
5456	0.25	0.40	0.10	0.50-1.0	4.7-5.5	0.05-0.20	0.25	0.20	...	0.05	0.15	rem
6005	0.6-0.9	0.35	0.10	0.10	0.40-0.6	0.10	0.10	0.10	...	0.05	0.15	rem
6005A <sup>J</sup>	0.50-0.9	0.35	0.30	0.50	0.40-0.7	0.30	0.20	0.10	...	0.05	0.15	rem
6013	0.6-1.0	0.50	0.6-1.1	0.20-0.8	0.8-1.2	0.10	0.25	0.10	...	0.05	0.15	rem
6020 <sup>K</sup>	0.40-0.9	0.50	0.30-0.9	0.35	0.6-1.2	0.15	0.20	0.15	...	0.05	0.15	rem
6026 <sup>L</sup>	0.6-1.4	0.7	0.20-0.50	0.20-1.0	0.6-1.2	0.30	0.30	0.20	...	0.05	0.05	rem
6041 <sup>M</sup>	0.50-0.9	0.15-0.7	0.15-0.6	0.05-0.20	0.8-1.2	0.05-0.15	0.25	0.15	...	0.05	0.15	rem
6042 <sup>N</sup>	0.50-1.2	0.7	0.20-0.6	0.40	0.7-1.2	0.04-0.35	0.25	0.15	...	0.05	0.15	rem
6060	0.30-0.6	0.10-0.30	0.10	0.10	0.35-0.6	0.5	0.15	0.10	...	0.05	0.15	rem
6061 <sup>O</sup>	0.40-0.8	0.7	0.15-0.40	0.15	0.8-1.2	0.04-0.35	0.25	0.15	...	0.05	0.15	rem
6063	0.20-0.6	0.35	0.10	0.10	0.45-0.9	0.10	0.10	0.10	...	0.05	0.15	rem
6064 <sup>P</sup>	0.40-0.8	0.7	0.15-0.40	0.15	0.8-1.2	0.05-0.14	0.25	0.15	...	0.05	0.15	rem
6066	0.9-1.8	0.50	0.7-1.2	0.6-1.1	0.8-1.4	0.40	0.25	0.20	...	0.05	0.15	rem
6070	1.0-1.7	0.50	0.15-0.40	0.40-1.0	0.50-1.2	0.10	0.25	0.15	...	0.05	0.15	rem
6082	0.7-1.3	0.50	0.10	0.40-1.0	0.6-1.2	0.25	0.20	0.10	...	0.05	0.15	rem
6105	0.6-1.0	0.35	0.10	0.15	0.45-0.8	0.10	0.10	0.10	...	0.05	0.15	rem
6162	0.40-0.8	0.50	0.20	0.10	0.7-1.1	0.10	0.25	0.10	...	0.05	0.15	rem
6262 <sup>Q</sup>	0.40-0.8	0.7	0.15-0.40	0.15	0.8-1.2	0.04-0.14	0.25	0.15	...	0.05	0.15	rem
6351	0.7-1.3	0.50	0.10	0.40-0.8	0.40-0.8	...	0.20	0.20	...	0.05	0.15	rem
6360	0.35-0.8	0.10-0.30	0.15	0.02-0.15	0.25-0.45	0.05	0.10	0.10	...	0.05	0.15	rem
6463	0.20-0.6	0.15	0.20	0.05	0.45-0.9	...	0.05	...	...	0.05	0.15	rem
6560	0.30-0.7	0.10-0.30	0.05-0.20	0.20	0.20-0.6	0.05	0.15	0.10	...	0.05	0.15	rem
7005 <sup>R</sup>	0.35	0.40	0.10	0.20-0.7	1.0-1.8	0.06-0.20	4.0-5.0	0.01-0.06	...	0.05	0.15	rem
7072 <sup>S</sup>	0.7 Si + Fe		0.10	0.10	0.10	...	0.8-1.3	...	...	...	...	rem
7075 <sup>T</sup>	0.40	0.50	1.2-2.0	0.30	2.1-2.9	0.18-0.28	5.1-6.1	0.20	...	0.05	0.15	rem
7116 <sup>U</sup>	0.15	0.30	0.50-1.1	0.05	0.8-1.4	...	4.2-5.2	0.05	0.05	0.05	0.15	rem
7129 <sup>U</sup>	0.15	0.30	0.50-0.9	0.10	1.3-2.0	0.10	4.2-5.2	0.05	0.05	0.05	0.15	rem

<sup>A</sup> Limits are in weight percent maximum unless shown as a range, or stated otherwise.

<sup>B</sup> Analysis shall be made for the elements for which limits are shown in this table.

<sup>C</sup> For the purpose of determining conformance to these limits, an observed value or a calculated value obtained from analysis shall be rounded to the nearest unit in the last right-hand place of the figures used in expressing the specified limit, in accordance with the rounding-off method of Practice E29.

<sup>D</sup> *Others* includes listed elements for which no specific limit is shown as well as unlisted metallic elements. The producer may analyze samples for trace elements not specified in the specification. However, such analysis is not required and may not cover all metallic *Others* elements. Should any analysis by the producer or the purchaser establish that an *Others* element exceeds the limit of *Each*, or that the aggregate of several *Others* elements exceeds the limit of *Total*, the material shall be considered nonconforming.

<sup>E</sup> *Other Elements*—Total shall be the sum of unspecified metallic elements 0.010 % or more, rounded to the second decimal before determining the sum.

<sup>F</sup> The aluminum content shall be calculated by subtracting from 100.00 % the sum of all metallic elements present in amounts of 0.010 % or more each, rounded to the second decimal before determining the sum.

<sup>G</sup> Be 0.0003 max for welding electrode, welding rod, and filler wire.

<sup>H</sup> Upon agreement between the purchaser and the producer or supplier, a Zr + Ti limit of 0.20 % max is permitted. Properties in Specification (Table 2) are not based on the Zirconium and Titanium algorithm.

<sup>I</sup> Zirconium, 0.10-0.25 %. The total for other elements does not include zirconium.

<sup>J</sup> Manganese plus chromium shall total 0.12-0.50.

<sup>K</sup> Lead 0.05 % max, Tin 0.9-1.5 %.

<sup>L</sup> Bismuth 0.50-1.5 %, Lead 0.4 % max, Tin 0.05 % max.

<sup>M</sup> Bismuth 0.30-0.9 %, Tin 0.35-1.2 %.

<sup>N</sup> Bismuth 0.20-0.8 %, Lead 0.15-0.40 %.

<sup>O</sup> In 1965 the requirements for 6062 were combined with those for 6061 by revising the minimum chromium from "0.15 %" to "0.04 %." This action cancelled alloy 6062.

<sup>P</sup> Bismuth 0.50-0.7 %, Lead 0.20-0.40 %.

<sup>Q</sup> Bismuth and lead shall be 0.40-0.7 % each.

<sup>R</sup> Zirconium 0.08-0.20 %. The total for other elements does not include zirconium.

<sup>S</sup> Composition of cladding alloy applied during the course of manufacture. Samples from finished tube shall not be required to conform to these limits.

<sup>T</sup> Upon agreement between the purchaser and the producer or supplier, a Zr + Ti limit of 0.25 % max is permitted. Properties in Specification (Table 2) are not based on the Zirconium and Titanium algorithm.

<sup>U</sup> Gallium 0.03 % max.

TABLE 2 Mechanical Property Limits<sup>A,B</sup>

NOTE 1—Strength values shown in parentheses are for information only.

Temper	Product Type <sup>C</sup>	Specified Section or Wall Thickness, in.	Area, in. <sup>2</sup>	Tensile Strength, ksi		Yield Strength, (0.2 % offset), ksi		Elongation in 2 in. or 4x Diameter, min, % <sup>D</sup>
				min	max	min	max	
Aluminum 1060 <sup>E</sup>								
O	Extruded Tube	all	all	8.5	14.0	2.5	...	25
H112	Extruded Tube	all	all	8.5	...	2.5	...	25
Aluminum 1100 <sup>E</sup>								
O	Extruded Tube	all	all	11.0	15.5	3.0	...	25
H112	Extruded Tube	all	all	11.0	...	3.0	...	25
Alloy 2014 <sup>E</sup>								
O	Extruded Wire, Rod, Bar, Profiles, and Tube	all	all	...	30.0	...	18.0	12
T4 T4510 <sup>F</sup> T4511 <sup>F</sup>	Extruded Wire, Rod, Bar, Profiles, and Tube	all	all	50.0	...	35.0	...	12
T42 <sup>G</sup>								
T6 T6510 <sup>F</sup> T6511 <sup>F</sup>	Extruded Wire, Rod, Bar, Profiles, and Tube	up through 0.499 0.500–0.749	all all	60.0 64.0	...	53.0 58.0	...	7 7
T62 <sup>G</sup>	Extruded Wire, Rod, Bar, Profiles, and Tube	up through 0.749 0.750 and over	all up through 25 over 25 through 32	60.0 60.0	...	53.0 53.0	...	7 6
O	Extruded Wire, Rod, Bar, Profiles, and Tube	all	all	...	35.0	...	19.0	12
T3 T3510 <sup>F</sup> T3511 <sup>F</sup>	Extruded Wire, Rod, Bar, and Profiles	up through 0.249 0.250–0.749 0.750–1.499	all all all	57.0 60.0 65.0	...	42.0 44.0 46.0	...	12 12 10
T3 T3510 <sup>F</sup> T3511 <sup>F</sup>	Extruded Tube	up through 0.249 0.250–0.749 0.750–1.499	all all all	57.0 60.0 65.0	...	42.0 44.0 46.0	...	10 10 10
T42 <sup>G</sup>	Extruded Wire, Rod, Bar, Profiles, and Tube	up through 0.749 0.750–1.499	all all	57.0 57.0	...	38.0 38.0	...	12 10

TABLE 2 Continued

Temper	Product Type <sup>C</sup>	Specified Section or Wall Thickness, in.	Area, in. <sup>2</sup>	Tensile Strength, ksi		Yield Strength, (0.2 % offset), ksi		Elongation in 2 in. or 4x Diameter, min, % <sup>D</sup>
				min	max	min	max	
Alloy 2024 <sup>E</sup> (Continued)								
T81 T8510 <sup>F</sup> T8511 <sup>F</sup>	Extruded Wire, Rod, Bar, Profiles, and Tube	0.050–0.249	all	64.0	...	56.0	...	4
		0.250–1.499	all	66.0	...	58.0	...	5
		1.500 and over	up through 32	66.0	...	58.0	...	5
Alloy 2219 <sup>E</sup>								
O	Extruded Wire, Rod, Bar, Profiles, and Tube	all	all	...	32.0	...	18.0	12
T31 T3510 <sup>F</sup> T3511 <sup>F</sup>	Extruded Wire, Rod, Bar, Profiles, and Tube	up through 0.499	up through 25	42.0	...	26.0	...	14
		0.500–2.999	up through 25	45.0	...	27.0	...	14
T62 <sup>G</sup>	Extruded Wire, Rod, Bar, Profiles, and Tube	up through 0.999	up through 25	54.0	...	36.0	...	6
		1.000 and over	up through 25	54.0	...	36.0	...	6
T81 T8510 <sup>F</sup> T8511 <sup>F</sup>	Extruded Wire, Rod, Bar, Profiles, and Tube	up through 2.999	up through 25	58.0	...	42.0	...	6
		Alloy 3003 <sup>E</sup>						
O	Extruded Wire, Rod, Bar, Profiles, and Tube	all	all	14.0	19.0	5.0	...	25
H112	Extruded Wire, Rod, Bar, and Profiles	all	all	14.0	...	5.0	...	...
H112	Extruded Tube	all	all	14.0	...	5.0	...	25
Alloy Alclad 3003 <sup>E</sup>								
O	Extruded Tube	all	all	13.0	18.0	4.5	...	25
H112	Extruded Tube	all	all	13.0	...	4.5'	...	25
Alloy 3004 <sup>E</sup>								
O	Extruded Tube	all	all	23.0	29.0	8.5	...	...
Alloy 3102								
H112	Extruded Tube	0.028–0.050	all	11.0	18.0	4.0	...	25
Alloy 5052 <sup>E</sup>								
O	Extruded Tube	all	all	25.0	35.0	10.0	...	...
Alloy 5083 <sup>E</sup>								
O	Extruded Wire, Rod, Bar, and Profiles	up through 5.000	up through 32	39.0	51.0	16.0	...	14
H111	Extruded Wire, Rod, Bar, and Profiles	up through 5.000	up through 32	40.0	...	24.0	...	12
H112	Extruded Wire, Rod, Bar, and Profiles	up through 5.000	up through 32	39.0	...	16.0	...	12
O	Extruded Tube	up through 2.999 <sup>H</sup>	up through 32	39.0	51.0	16.0	...	14
H111	Extruded Tube	up through 2.999 <sup>H</sup>	up through 32	40.0	...	24.0	...	12
H112	Extruded Tube	up through 2.999 <sup>H</sup>	up through 32	39.0	...	16.0	...	12
Alloy 5086 <sup>E</sup>								
O	Extruded Wire, Rod, Bar, and Profiles	up through 5.000	up through 32	35.0	46.0	14.0	...	14
H111	Extruded Wire, Rod, Bar, and Profiles	up through 5.000	up through 32	36.0	...	21.0	...	12
H112	Extruded Wire, Rod, Bar, and Profiles	up through 5.000	up through 32	35.0	...	14.0	...	12
O	Extruded Tube	up through 2.999 <sup>H</sup>	up through 32	35.0	46.0	14.0	...	14

ASMENORMDOC.COM · Click to view the full PDF of ASME BPVC.II.B (ASME BPVC Section II part B) 2025

TABLE 2 Continued

Temper	Product Type <sup>C</sup>	Specified Section or Wall Thickness, in.	Area, in. <sup>2</sup>	Tensile Strength, ksi		Yield Strength, (0.2 % offset), ksi		Elongation in 2 in. or 4x Diameter, min, % <sup>D</sup>
				min	max	min	max	
Alloy 5086 <sup>E</sup> (Continued)								
H111	Extruded Tube	up through 2.999 <sup>H</sup>	up through 32	36.0	...	21.0	...	12
H112	Extruded Tube	up through 2.999 <sup>H</sup>	up through 32	35.0	...	14.0	...	12
Alloy 5154								
O	Extruded Wire, Rod, Bar, Profiles, and Tube	all	all	30.0	41.0	11.0	...	...
H112	Extruded Wire, Rod, Bar, Profiles, and Tube	all	all	30.0	...	11.0	...	...
Alloy 5454 <sup>E</sup>								
O	Extruded Wire, Rod, Bar, and Profiles	up through 5.000	up through 32	31.0	41.0	12.0	...	14
H111	Extruded Wire, Rod, Bar, and Profiles	up through 5.000	up through 32	33.0	...	19.0	...	12
H112	Extruded Wire, Rod, Bar, and Profiles	up through 5.000	up through 32	31.0	...	12.0	...	12
O	Extruded Tube	up through 2.999 <sup>H</sup>	up through 32	31.0	41.0	12.0	...	14
H111	Extruded Tube	up through 2.999 <sup>H</sup>	up through 32	33.0	...	19.0	...	12
H112	Extruded Tube	up through 2.999 <sup>H</sup>	up through 32	31.0	...	12.0	...	12
Alloy 5456 <sup>E</sup>								
O	Extruded Wire, Rod, Bar, and Profiles	up through 5.000	up through 32	41.0	53.0	19.0	...	14
H111	Extruded Wire, Rod, Bar, and Profiles	up through 5.000	up through 32	42.0	...	26.0	...	12
H112	Extruded Wire, Rod, Bar, and Profiles	up through 5.000	up through 32	41.0	...	19.0	...	12
O	Extruded Tube	up through 2.999	up through 32	41.0	53.0	19.0	...	14
H111	Extruded Tube	up through 2.999 <sup>I</sup>	up through 32	42.0	...	26.0	...	12
H112	Extruded Tube	up through 2.999 <sup>I</sup>	up through 32	41.0	...	19.0	...	12
Alloy 6005								
T1	Extruded Wire, Rod, Bar, Profiles, and Tube	up through 0.500	all	25.0	...	15.0	...	16
T5	Extruded Wire, Rod, Bar, Profiles, and Tube	up through 0.124 0.125–1.000	all	38.0	...	35.0	...	8
			all	38.0	...	35.0	...	10
Alloy 6005A								
T1	Extruded Wire, Rod, Bar, Profiles, and Tube	up through 0.249	all	25.0	...	14.5	...	15
T5	Extruded Wire, Rod, Bar, Profiles, and Tube	up through 0.249 0.250–0.999	all	38.0	...	31.0	...	7
			all	38.0	...	31.0	...	9
T6 T61	Extruded Wire, Rod, Bar, Profiles, and Tube	up through 0.249 0.250–1.000	all	38.0	...	35.0	...	8
			all	38.0	...	35.0	...	10
Alloy 6013								
T6 T6511 <sup>F</sup>	Extruded Wire, Rod, Bar, Profiles, and Tube	0.200–0.499 0.500–0.749 0.750–2.000	all	49.0	...	46.0	...	8
			all	49.0	...	46.0	...	8
			all	49.0	...	45.0	...	8

TABLE 2 Continued

Temper	Product Type <sup>C</sup>	Specified Section or Wall Thickness, in.	Area, in. <sup>2</sup>	Tensile Strength, ksi		Yield Strength, (0.2 % offset), ksi		Elongation in 2 in. or 4x Diameter, min, % <sup>D</sup>								
				min	max	min	max									
Alloy 6020																
T6511 <sup>F</sup>	Extruded Rod and Bar	3.250–6.000	all	38.0	...	35.0	...	10								
Alloy 6026																
T6 T6510 <sup>F</sup> T6511 <sup>F</sup>	Extruded Profiles	0.200–1.500	all	49.0	...	38.0	...	6								
T6 T6510 <sup>F</sup> T6511 <sup>F</sup>									Extruded Tube	0.400–1.300	all	49.0	...	38.0	...	6
T6 T6510 <sup>F</sup> T6511 <sup>F</sup>																
T6 T6510 <sup>F</sup> T6511 <sup>F</sup>	Extruded Wire, Rod, and Bar	1.300–5.500	all	54.0	...	44.0	...	6								
		5.501–8.000	all	49.0	...	36.0	...	6								
		8.001–10.000	all	44.0	...	29.0	...	6								
Alloy 6041																
T6, T6511 <sup>F</sup>	Extruded Rod, Bar, and Profiles	0.400–2.000	all	45.0	...	40.0	...	10								
Alloy 6042																
T5, T5511 <sup>F</sup>	Extruded Rod, Bar, and Profiles	0.400–0.499	all	38.0	...	35.0	...	10								
		0.500–1.800	all	42.0	...	35.0	...	10								
Alloy 6060																
T51	Extruded Wire, Rod, Bar, and Profiles	up through 0.125	all	22.0	...	16.0	...	8								
T61	Extruded Wire, Rod, Bar, and Profiles	up through 0.124	all	30.0	...	25.0	...	8								
		0.125–1.000		30.0		25.0		10								
Alloy 6061 <sup>E</sup>																
O	Extruded Wire, Rod, Bar, Profiles, and Tube	all	all	...	22.0	...	16.0	16								
T1	Extruded Wire, Rod, Bar, Profiles, and Tube	up through 0.625	all	26.0	...	14.0	...	16								
T4 T4510 <sup>F</sup> T4511 <sup>F</sup>	Extruded Wire, Rod, Bar, Profiles, and Tube	all	all	26.0	...	16.0	...	16								
T42 <sup>G</sup>									Extruded Wire, Rod, Bar, Profiles, and Tube	all	all	26.0	...	12.0	...	16
T51									Extruded Wire, Rod, Bar, Profiles, and Tube	up through 0.625	all	35.0	...	30.0	...	8
T6, T62 <sup>G</sup> T6510 <sup>F</sup> T6511 <sup>F</sup>	Extruded Wire, Rod, Bar, Profiles, and Tube	up through 0.249	all	38.0	...	35.0	...	8								
				0.250 and over		all		38.0	35.0	10						
Alloy 6063																
O	Extruded Wire, Rod, Bar, Profiles, and Tube	all	all	...	19.0	...	...	18								
T1	Extruded Wire, Rod, Bar, Profiles, and Tube	up through 0.500	all	17.0	...	9.0	...	12								
		0.501–1.000	all	16.0	...	8.0	...	12								
T4, T42 <sup>G</sup>	Extruded Wire, Rod, Bar, Profiles, and Tube	up through 0.500	all	19.0	...	10.0	...	14								
			all	18.0	...	9.0	...	14								

TABLE 2 Continued

Temper	Product Type <sup>C</sup>	Specified Section or Wall Thickness, in.	Area, in. <sup>2</sup>	Tensile Strength, ksi		Yield Strength, (0.2 % offset), ksi		Elongation in 2 in. or 4x Diameter, min, % <sup>D</sup>	
				min	max	min	max		
Alloy 6063 (Continued)									
T5	Extruded Wire, Rod, Bar, Profiles, and Tube	{	up through 0.500	all	22.0	...	16.0	...	8
			0.501–1.000	all	21.0	...	15.0	...	8
T52	Extruded Wire, Rod, Bar, Profiles, and Tube		up through 1.000	all	22.0	30.0	16.0	25.0	8
T54	Extruded Wire, Rod, Bar, Profiles, and Tube	{	up through 0.124	all	33.0	...	30.0	...	8
			0.125–0.499	all	33.0	...	30.0	...	10
T6, T62 <sup>G</sup>	Extruded Wire, Rod, Bar, Profiles, and Tube	{	up through 0.124	all	30.0	...	25.0	...	8
			0.125–1.000	all	30.0	...	25.0	...	10
T65	Extruded Wire, Rod, Bar, Profiles, and Tube		up through 0.182	all	36.0	...	33.0	...	8
Alloy 6064									
T6, T6511 <sup>F</sup>	Extruded Rod, Bar, and Profiles		0.180–3.250	all	42.0	...	38.0	...	10
Alloy 6066									
O	Extruded Wire, Rod, Bar, Profiles, and Tube		all	all	...	29.0	...	18.0	16
T4 T4510 <sup>F</sup> T4511 <sup>F</sup>	Extruded Wire, Rod, Bar, Profiles, and Tube	}	all	all	40.0	...	25.0	...	14
T42 <sup>G</sup>	Extruded Wire, Rod, Bar, Profiles, and Tube		all	all	40.0	...	24.0	...	14
T6 T6510 <sup>F</sup> T6511 <sup>F</sup>	Extruded Wire, Rod, Bar, Profiles, and Tube	}	all	all	50.0	...	45.0	...	8
T62 <sup>G</sup>	Extruded Wire, Rod, Bar, Profiles, and Tube		all	all	50.0	...	42.0	...	8
Alloy 6070									
T6, T62 <sup>G</sup>	Extruded Wire, Rod, Bar, Profiles, and Tube		up through 2.999	up through 32	48.0	...	45.0	...	6
Alloy 6082									
T6, T6511 <sup>F</sup>	Extruded Wire, Rod, Bar, and Profiles	{	0.200–0.750	all	45.0	...	38.0	...	6
			0.751–6.000	all	45.0	...	38.0	...	8
			6.001–8.000	all	41.0	...	35.0	...	6
T6	Extruded Tube		0.200–1.000	all	45.0	...	38.0	...	8
Alloy 6105									
T1	Extruded Wire, Rod, Bar, Profiles, and Tube		up through 0.500	all	25.0	...	15.0	...	16
T5	Extruded Wire, Rod, Bar, Profiles, and Tube	{	up through 0.500	all	38.0	...	35.0	...	8
T6	Extruded Wire, Rod, Bar, and Profiles		up through 0.500	all	38.0	...	35.0	...	8

TABLE 2 Continued

Temper	Product Type <sup>C</sup>	Specified Section or Wall Thickness, in.	Area, in. <sup>2</sup>	Tensile Strength, ksi		Yield Strength, (0.2 % offset), ksi		Elongation in 2 in. or 4x Diameter, min, % <sup>D</sup>
				min	max	min	max	
Alloy 6162								
T5 T5510 <sup>F</sup> T5511 <sup>F</sup>	Extruded Wire, Rod, Bar, Profiles, and Tube	up thru 1.000	all	37.0	...	34.0	...	7
T6 T6510 <sup>F</sup> T6511 <sup>F</sup>								
T6 T6510 <sup>F</sup> T6511 <sup>F</sup>	Extruded Wire, Rod, Bar, Profiles, and Tube	up thru 0.249 0.250–0.499	all all	38.0 38.0	...	35.0 35.0	...	8 10
T6, T62 <sup>G</sup> T6510 <sup>F</sup> T6511 <sup>F</sup>								
Alloy 6262								
T6, T62 <sup>G</sup> T6510 <sup>F</sup> T6511 <sup>F</sup>	Extruded Wire, Rod, Bar, Profiles, and Tube	all	all	38.0	...	35.0	...	10
Alloy 6351								
T1	Extruded Wire, Rod, Bar, and Profiles	up through 0.499	up through 20	26.0	...	13.0	...	15
T11	Extruded Wire, Rod, Bar, and Profiles	up through 0.749	all	26.0	...	16.0	...	16
T4	Extruded Wire, Rod, Bar, Profiles, and Tube	up through 0.749	all	32.0	...	19.0	...	16
T5	Extruded Wire, Rod, Bar, and Profiles	up through 0.249 0.250–1.000	all all	38.0 38.0	...	35.0 35.0	...	8 10
T51								
T51	Extruded Wire, Rod, Bar, and Profiles	0.125–1.000	up through 20	36.0	...	33.0	...	10
T54	Extruded Wire, Rod, Bar, and Profiles	up through 0.500	up through 20	30.0	...	20.0	...	10
T6	Extruded Wire, Rod, Bar, Profiles, and Tube	up through 0.124 0.125–0.749	all all	42.0 42.0	...	37.0 37.0	...	8 10
T6								
Alloy 6360								
T5	Extruded Wire, Rod, Bar, and Profiles	up through 0.250	all	22.0	...	16.0	...	8
T6	Extruded Wire, Rod, Bar, and Profiles	up through 0.120 0.121–0.250	all all	30.0 30.0	...	25.0 25.0	...	8 10
T6								
Alloy 6463								
T1	Extruded Wire, Rod, Bar, and Profiles	up through 0.500	up through 20	17.0	...	9.0	...	12
T5	Extruded Wire, Rod, Bar, and Profiles	up through 0.500	up through 20	22.0	...	16.0	...	8
T6, T62 <sup>G</sup>	Extruded Wire, Rod, Bar, and Profiles	up through 0.124 0.125–0.500	up through 20 up through 20	30.0 30.0	...	25.0 25.0	...	8 10
T6, T62 <sup>G</sup>								
Alloy 6560								
T5	Extruded Wire, Rod, Bar, Profiles, and Tube	0.090–0.125	all	22.0	...	16.0	...	8
T6	Extruded Wire, Rod, Bar, Profiles, and Tube	0.090–0.125	all	30.0	...	25.0	...	8
Alloy 7005								
T53	Extruded Wire, Rod, Bar, and Profiles	up through 0.750	all	50.0	...	44.0	...	10

Click to view the full PDF of ASME BPVC.II.B (ASME BPVC Section II part B) 2025

ASMENORMDOC.COM

TABLE 2 Continued

Temper	Product Type <sup>C</sup>	Specified Section or Wall Thickness, in.	Area, in. <sup>2</sup>	Tensile Strength, ksi		Yield Strength, (0.2 % offset), ksi		Elongation in 2 in. or 4x Diameter, min, % <sup>D</sup>
				min	max	min	max	
Alloy 7075 <sup>E</sup>								
O	Extruded Wire, Rod, Bar, Profiles, and Tube	all	all	...	40.0	...	24.0	10
T6, T62 <sup>G</sup> T6510 <sup>F</sup> T6511 <sup>F</sup>	Extruded Wire, Rod, Bar, and Profiles	up through 0.249	all	78.0	...	70.0	...	7
		0.250–0.499	all	81.0	...	73.0	...	7
		0.500–1.499	all	81.0	...	72.0	...	7
		1.500–2.999	all	81.0	...	72.0	...	7
		3.000–4.499	up through 20 over 20 through 32	81.0	...	71.0	...	7
78.0	...			70.0	...	6		
4.500–5.000	up through 32	78.0	...	68.0	...	6		
T6, T62 <sup>G</sup> T6510 <sup>F</sup> T6511 <sup>F</sup>	Extended Tube	up through 0.249	all	78.0	...	70.0	...	7
		0.250–0.499	all	81.0	...	73.0	...	7
		0.500–1.499	all	81.0	...	72.0	...	7
		1.500–2.999	all	81.0	...	72.0	...	7
T73 T73510 <sup>F</sup> T73511 <sup>F</sup>	Extruded Wire, Rod, Bar and Profiles	0.062–0.249	up through 20	68.0	...	58.0	...	7
		0.250–1.499	up through 25	70.0	...	61.0	...	8
			up through 25	69.0	...	59.0	...	8
		3.000–4.499	up through 20 over 20 through 32	68.0	...	57.0	...	7
				65.0	...	55.0	...	7
4.500–5.000	up through 36	65.0	...	53.0	...	7		
T73 T73510 <sup>F</sup> T73511 <sup>F</sup>	Extended Tube	0.062–0.249	all	68.0	...	58.0	...	7
		0.250–1.499	up through 25	70.0	...	61.0	...	8
		1.500–2.999	up through 25	69.0	...	59.0	...	8
T76 T76510 <sup>F</sup> T76511 <sup>F</sup>	Extruded Wire, Rod, Bar, and Profiles	up through 0.049	all	73.0	...	63.0	...	7
		0.050–0.124	all	74.0	...	64.0	...	7
		0.125–0.249	up through 20	74.0	...	64.0	...	7
		0.250–0.499	up through 20	75.0	...	65.0	...	7
		0.500–1.000	up through 20	75.0	...	65.0	...	7
		1.001–2.000	up through 20	75.0	...	65.0	...	7
		2.001–3.000	up through 20	74.0	...	64.0	...	7
		3.001–4.000	up through 20	74.0	...	63.0	...	7
Alloy 7116								
T5	Extrusion	0.125–0.500	all	48.0	...	42.0	...	8
Alloy 7129								
T5, T6	Extrusion	up through 0.500	all	55.0	...	49.0	...	9

<sup>A</sup> The basis for establishment of tensile property limits is shown in Annex A1.

<sup>B</sup> To determine conformance to this specification, each value shall be rounded to the nearest 0.1 ksi for strength and nearest 0.5 % for elongation in accordance with the rounding-off-method of Practice E29.

<sup>C</sup> Product type as specified in by Aluminum Association Registrations found in Yellow Sheets and AS&D

<sup>D</sup> Elongation of full-section and cut-out sheet-type specimens is measured in 2 in. Elongation of cut-out round specimens is measured in 4x specimen diameter. See 8.1.1 and 8.1.2 for conditions under which measurements are not required.

<sup>E</sup> These alloys are also produced in the F temper for which no tensile properties are specified or guaranteed.

<sup>F</sup> For stress relieved tempers (T3510, T3511, T4510, T4511, T5510, T5511, T6510, T6511, T73510, T73511, T76510, T76511, T8510, T8511), characteristics and properties other than those specified may differ somewhat from the corresponding characteristics and properties of material in the basic tempers.

<sup>G</sup> Material in the T42 and T62 tempers is not available from the material producers.

<sup>H</sup> Specified wall thickness range is limited to 2.999 in. This differs from Aluminum Standards and Data, which specifies wall thickness range as "All."

<sup>I</sup> Specified wall thickness range is limited to 2.999 in. This differs from Aluminum Association Yellow Sheets, which specifies wall thickness range as 5.000 in for all extrusion products.

**TABLE 3 Ultrasonic Discontinuity Limits for Extruded Bar and Profiles<sup>A</sup>**

Alloy	Thickness, <sup>B</sup> in.	Weight, max per Piece, lb	Max Width: Thickness Ratio	Discontinuity Class <sup>C</sup>				
2014 2024 2219	0.500 and over	600	10:1	B				
7075					0.500–1.499	600	10:1	B
					1.500 and over	600	10:1	A

<sup>A</sup> Discontinuities in excess of those listed in this table shall be allowed, subject to the approval of the procuring activity, if it is established that they will be removed by machining or that they are in noncritical areas.

<sup>B</sup> The thickness of any element of a profile shall be deemed to be the smallest dimension of that element and the discontinuity class applicable to that particular thickness shall apply to that element of the profile.

<sup>C</sup> The discontinuity class limits are defined in Section 11 of Practice B594.

4.2.8 Requirements for tensile property and dimensional tolerance for sizes not specifically covered (8.1.3 and 15.1.1).

4.2.9 Whether Titanium and Zirconium algorithm is allowed as shown in Table 1 (Footnote H), when ordering 2014 or 2024.

4.2.10 Whether Titanium and Zirconium algorithm is allowed as shown in Table 1 (Footnote T), when ordering 7075.

## 5. Materials and Manufacture

5.1 The products covered by this specification shall be produced by the hot extrusion method or by similar methods at the option of the producer, provided that the resulting products comply with the requirements in this specification.

## 6. Quality Assurance

6.1 *Responsibility for Inspection and Tests*—Unless otherwise specified in the contract or purchase order, the producer is responsible for the performance of all inspection and test requirements specified herein. The producer may use his own or any other suitable facilities for the performance of the inspection and test requirements specified herein, unless disapproved by the purchaser in the order or at the time of contract signing. The purchaser shall have the right to perform any of the inspections and tests set forth in this specification where such inspections are deemed necessary to ensure that material conforms to prescribed requirements.

6.2 *Lot Definition*—An inspection lot shall be defined as follows:

6.2.1 For heat-treated tempers, an inspection lot shall consist of an identifiable quantity of material of the same mill form, alloy, temper, and nominal dimensions traceable to a heat-treat lot or lots, and subjected to inspection at one time.

6.2.2 For nonheat-treated tempers, an inspection lot shall consist of an identifiable quantity of material of the same mill form, alloy, temper, and nominal dimensions subjected to inspection at one time.

## 7. Chemical Composition

7.1 *Limits*—The material shall conform to the chemical composition limits in Table 1. Conformance shall be deter-

mined by the producer by taking samples in accordance with Practices E716 when the ingots are poured and analyzing those samples in accordance with Test Methods E1251, E3061, or EN 14242. At least one sample shall be taken for each group of ingots poured simultaneously from the same source of molten metal. If the producer has determined the chemical composition during pouring of the ingots, they shall not be required to sample and analyze the finished product.

NOTE 6—It is standard practice in the United States aluminum industry to determine conformance to the chemical composition limits prior to further processing of ingots into wrought products. Due to the continuous nature of the process, it is not practical to keep a specific ingot analysis identified with a specific quantity of finished material.

7.2 If it becomes necessary to analyze extrusions for conformance to chemical composition limits, the methods of sampling and methods of analysis shall be as provided in the following:

7.2.1 *Methods of Sampling*—Samples for chemical analysis shall be taken in accordance with Practice B985

7.2.2 *Methods of Analysis*—Analysis shall be performed in accordance with Test Method E1251, E3061, or EN 14242.

7.3 Other methods of analysis, or in the case of dispute, may be decided by agreement between the producer and the purchaser.

NOTE 7—It is difficult to obtain a reliable analysis of each of the components of clad materials using material in its finished state. A reasonably accurate determination of the core composition can be made if the cladding is substantially removed prior to analysis. The cladding composition is more difficult to determine because of the relatively thin layer and because of diffusion of core elements to the cladding. The correctness of cladding alloy used can usually be verified by a combination of metallographic examination and spectrochemical analysis of the surface at several widely separated points.

## 8. Tensile Properties of Material from Producer

8.1 *Limits*—The material shall conform to the tensile property requirements specified in Table 2.

8.1.1 The elongation requirements shall not be applicable to the following:

8.1.1.1 Material of such dimensions that a standard test specimen cannot be taken in accordance with Test Method B557, and of such a profile that it cannot be satisfactorily tested in full section.

8.1.1.2 Material thinner than 0.062 in.

8.1.1.3 Wire less than 0.125 in. in diameter.

8.1.2 The measurement for yield strength is not required for wire less than 0.125 in. in diameter.

8.1.3 Tensile property limits for sizes not covered in Table 2 shall be as agreed upon between the producer and purchaser, and shall be so specified in the contract or purchase order.

8.2 *Number of Specimens:*

8.2.1 For material having a nominal weight of less than 1 lb/linear ft, one tension test specimen shall be taken for each 1000 lb or fraction thereof in the lot.

8.2.2 For material having a nominal weight of 1 lb or more per linear foot, one tension test specimen shall be taken for each 1000 ft or fraction thereof in the lot.

8.2.3 Other procedures for selecting samples may be employed if agreed upon between the producer or supplier and the purchaser.

8.3 Geometry of test specimens and the location in the product from which they are taken shall be as specified in Test Method B557.

8.4 *Test Methods*—The tension tests shall be made in accordance with Test Method B557.

8.5 *Retests*—When there is evidence that the test specimen is defective or is not representative of the lot of material, retesting may be performed in accordance with Sections 8 and 9 of Test Method B557.

## 9. Heat Treatment

9.1 Producer or supplier heat treatment for the production of T1, T2, T5, and T10-type tempers shall be in accordance with Practice B945. Producer or supplier heat treatment for the production of T3, T4, T6, T7, T8, and T9-type tempers, unless otherwise specified in 9.2 or unless otherwise specified in 9.3, shall be in accordance with AMS 2772.

9.2 Unless otherwise specified (4.2.1), alloys 6005A, 6013, 6041, 6060, 6061, 6063, 6064, 6066, 6070, 6082, 6105, 6162, 6262, 6351, 6360, 6463, 6560, and 7129 may be solution heat treated and quenched at the extrusion press in accordance with Practice B807/B807M for the production of T3, T4 T6, T7, T8, and T9-type tempers.

9.3 When specified (4.2.2), heat treatment of the production of T3, T4, T6, T7, T8 and T9-type tempers shall be in accordance with Practice B918/B918M.

## 10. Producer Confirmation of Heat-Treat Response

10.1 In addition to the requirements of Section 8, material in alloys 2014, 2024, and 6061 produced in the O or F temper (within the size limits specified in Table 2) shall, after proper solution heat treatment and natural aging for not less than 4 days at room temperature, conform to the properties specified in Table 2 for T42 temper material. The heat-treated sample may be tested prior to 4 days natural aging but if they fail to conform to the T42 temper properties, the test may be repeated after completion of 4 days natural aging without prejudice.

10.2 Alloys 2219, and 7075 material produced in the O or F temper, (within the size limits specified in Table 2) shall, after proper solution heat treatment and precipitation heat treatment, conform to the properties specified in Table 2 for T62 temper material.

10.3 *Number of Specimens*—The number of specimens from each lot of O temper material and F temper material to be tested to verify conformance with 10.1 and 10.2 shall be as specified in 8.2.

## 11. Heat Treatment and Reheat-Treatment Capability

11.1 As-received material in the O or F temper in alloys 2014, 2024, and 6061 (within the size limitations specified in Table 2 and without the imposition of cold work) shall be capable of conforming to the properties specified in Table 2 for

T42 temper, upon being properly solution heat-treated and naturally aged for not less than 4 days at room temperature.

11.2 As-received material in the O and F tempers in alloys 2219 and 7075 (within the size limitations specified in Table 2 and without the imposition of cold work) shall be capable of conforming to the properties specified in Table 2 for the T62 temper, upon being properly solution and precipitation heat-treated.

11.3 Material in alloys and tempers 2014-T4, T4510, T4511, T6, T6510, and T6511, and 2024-T3, T3510, T3511, T81, T8510, and T8511, shall be capable of conforming to the properties specified in Table 2 for the T42 temper, upon being properly resolution heat-treated and naturally aged for not less than 4 days at room temperature.

NOTE 8—Beginning with the 1975 revision, 6061-T4, T6, T4510, T4511, T6510, and T6511 were deleted from 11.3 because experience has shown the reheat-treated material tends to develop large recrystallized grains and may fail to develop the tensile properties shown in Table 2.

11.4 Alloy 2219 in the T31, T3510, T3511, T81, T8510, and T8511 tempers, and alloy 7075 in the T6, T651, T6510, and T6511 tempers, shall be capable of conforming to the properties specified in Table 2 for the T62 temper, upon being properly resolution heat-treated and precipitation heat-treated.

11.5 Material in T3/T31, T3510, T3511, T4, T4510, and T4511 tempers shall be capable of conforming, upon being properly precipitation heat-treated, to the properties specified in Table 2 for the T81, T8510, T8511, T6, T6510, and T6511 tempers, respectively.

## 12. Stress-Corrosion Resistance

12.1 Alloy 7075 in the T73 and T76-type tempers shall be capable of exhibiting no evidence of stress-corrosion cracking when subjected to the test specified in 12.2.

12.1.1 For lot-acceptance purposes, resistance to stress-corrosion cracking for each lot of material shall be established by testing the previously selected tension-test samples to the criteria shown in Table 4.

12.1.2 For surveillance purposes, each month the producer shall perform at least one test for stress corrosion resistance in accordance with 12.2 on each applicable alloy-temper, for each thickness range 0.750 in. and over produced that month. Each sample shall be taken from material considered acceptable in accordance with the lot-acceptance criteria of Table 4. A minimum of three adjacent replicate specimens shall be taken from each sample and tested. The producer shall maintain records of all lots so tested and make them available for examination at the producer's facility.

12.2 The stress-corrosion cracking test shall be performed on material 0.750 in. and over in thickness as follows:

12.2.1 Specimens shall be stressed in tension in the short transverse direction with respect to grain flow and held at constant strain. The stress level shall be 75 % of the specified minimum yield strength for T73-type tempers and 25 ksi for T76-type tempers.

12.2.2 The stress-corrosion test shall be made in accordance with Test Method G47.

TABLE 4 Lot Acceptance Criteria for Resistance to Stress Corrosion and Exfoliation Corrosion

Alloy and Temper	Lot Acceptance Criteria		Lot Acceptance Status
	Electrical Conductivity, % IACS <sup>A</sup>	Level of Mechanical Properties	
7075-T73, T73510, and T73511	40.0 or greater	in accordance with specified requirements	acceptable
	38.0 through 39.9	in accordance with specified requirements and yield strength does not exceed minimum by more than 11.9 ksi	acceptable
	38.0 through 39.9	in accordance with specified requirements but yield strength exceeds minimum by 12.0 ksi or more	unacceptable <sup>B</sup>
7075-T76, T76510, and T76511	less than 38.0	any level	unacceptable <sup>B</sup>
	38.0 or greater	in accordance with specified requirements	acceptable
	36.0 through 37.9	in accordance with specified requirements	suspect <sup>C</sup>
T76510, and T76511	less than 36.0	any level	unacceptable <sup>B</sup>
	38.0 or greater	in accordance with specified requirements	acceptable
	35.0 through 37.9	in accordance with specified requirements	suspect <sup>C</sup>
	less than 35.0	any level	unacceptable <sup>B</sup>

<sup>A</sup> Sampling for electrical conductivity tests shall be the same as for tensile tests as specified in 8.2. Test specimens may be prepared by machining a flat, smooth surface of sufficient width for proper testing. For small sizes of tubes, a cut-out portion may be flattened and the conductivity determined on the surface. Chemical milling may be used on flat surface samples. The electrical conductivity shall be determined in accordance with Practice E1004 in the following locations:

<sup>B</sup> When material is found to be unacceptable, it shall be reprocessed (additional precipitation heat treatment or re-solution heat treatment, stress relieving, straightening, and precipitation heat treatment, when applicable).

<sup>C</sup> When material in these tempers is found to be suspect it is either tested for exfoliation corrosion resistance in accordance with Test Method G34 and stress corrosion in accordance with Test Method G47, or it is reprocessed (additional precipitation heat treatment or resolution heat treatment and precipitation heat treatment). Favorable exfoliation corrosion test results must never be used as acceptance criteria for stress corrosion resistance.

Section thickness, in.			Location
Over	Through		
...	0.100	surface of tension sample	subsurface at approximate center of section thickness, on a plane parallel to the longitudinal center line of the material
0.100	0.500	subsurface after removal of approximately 10 % of the thickness	
0.500	1.500	subsurface on tension-test specimen surface that is closest to the center of the section thickness and on a plane parallel to the extrusion surface	
1.500	...		

12.2.3 There shall be no visual evidence of stress-corrosion cracking in any specimen, except that the retest provisions of 19.2 shall apply.

**13. Exfoliation-Corrosion Resistance**

13.1 Alloy 7075 in the T76, T76510, and T76511 tempers shall be capable of exhibiting no evidence of exfoliation corrosion equivalent to or in excess of that illustrated by Category B in Fig. 2 of Test Method G34 when tested in accordance with 13.1.1.

13.1.1 For surveillance purposes, each month at least one exfoliation-corrosion test shall be performed for each size range of extrusions produced during that month. The test shall be in accordance with Test Method G34 on material considered acceptable in accordance with lot-acceptance criteria of Table 4. Specimens shall be selected at random and shall be, if possible, a minimum of 2 by 4 in. with the 4-in. dimension in a plane parallel to the direction of extrusion. The test location shall be in accordance with that specified in Table 4. The producer shall maintain records of all surveillance test results and make them available for examination at the producer's facility.

13.2 For lot-acceptance purposes, resistance to exfoliation corrosion for each lot of material in the alloys and tempers listed in 13.1 shall be established by testing the previously selected tension-test samples to the criteria shown in Table 4.

**14. Cladding**

14.1 The aluminum-alloy cladding on clad tube shall comprise the inside surface (only) of the tube and its thickness shall be approximately 10 % of the total wall thickness.

14.2 When the cladding thickness is to be determined on finished tube, transverse cross sections of at least three tubes from the lot shall be polished for examination with a metal-lurgical microscope. Using a 100x magnification, the cladding thickness at four points 90° apart in each sample shall be measured and the average of the 12 measurements shall be taken as the thickness. For a tube having a diameter larger than can be properly mounted for polishing and examination, the portions of the cross section polished for examination may consist of an arc about 1/2 in. in length.

**15. Dimensional Tolerances**

15.1 *Dimensions*—Variations from the specified dimensions for the type of material ordered shall not exceed the permissible variations prescribed in the tables of ANSI H35.2 (see Table 5).

15.1.1 Dimensional tolerances for sizes not covered in ANSI H35.2 shall be agreed upon between the producer and purchaser and shall be specified in the contract or purchase order.

TABLE 5 Tables of ANSI H35.2

Table No.	Title
11.2	Cross-Sectional Dimension Tolerances: Profiles Except for Profiles in T3510, T4510, T6510, T73510, T76510 and T8510 Tempers
11.3	Diameter or Distance across Flats—Round Wire and Rod—Square, Hexagonal and Octagonal Wire and Bar
11.4	Thickness or Width (Distance Across Flats)—Rectangular Wire and Bar
11.5	Length: Wire, Rod, Bar and Profiles
11.6	Straightness: Rod, Bar and Profiles
11.7	Twist—Bar and Profiles
11.8	Flatness (Flat Surfaces)—Bar, Solid Profiles and Semihollow Profiles Except for O, T3510, T4510, T6510, T73510, T76510 and T8510 Tempers
11.9	Flatness (Flat Surfaces)—Hollow Profiles Except for O, T3510, T4510, T6510, T73510, T76510 and T8510 Tempers
11.10	Surface Roughness—Wire, Rod, Bar and Profiles
11.11	Contour (Curved Surfaces) Profiles
11.12	Squareness of Cut Ends—Wire, Rod, Bar and Profiles
11.13	Corner and Fillet Radii—Bar and Profiles
11.14	Angularity—Bar and Profiles Except for O, T3510, T4510, T6510, T73510, T76510, and T8510 Tempers
12.2	Diameter Round Tube Except for T3510, T4510, T6510, T73510, T76510 and T8510 Tempers
12.3	Width and Depth—Square, Rectangular, Hexagonal, Octagonal Tube Except for T3510, T4510, T6510, T73510, T76510 and T8510 Temper
12.4	Wall Thickness—Round Extruded Tube
12.5	Wall Thickness—Other Than Round Extruded Tube
12.6	Length—Extruded Tube
12.7	Twist—Other Than Round Extruded Tube
12.8	Straightness—Tube in Straight Lengths
12.9	Flatness (Flat Surfaces)
12.10	Squareness of Cut Ends
12.11	Corner and Fillet Radii: Tube Other Than Round
12.12	Angularity: Tube Other Than Round
12.13	Surface Roughness: Extruded Tube
12.14	Dents: Extruded Tube

15.2 *Sampling for Inspection*—Examination for dimensional conformance shall be made to ensure conformance to the tolerance specified.

## 16. General Quality

16.1 Unless otherwise specified the extruded bar, rod, wire, profile, and tube shall be supplied in the mill finish and shall be uniform as defined by the requirements of this specification and shall be commercially sound. Any requirement not so covered is subject to negotiation between the producer and purchaser.

16.2 Each bar, rod, wire, profile, or tube shall be examined to determine conformance to this specification with respect to general quality and identification marking. On approval of the purchaser, however, the producer or the supplier may use a system of statistical quality control for such examination.

## 17. Internal Quality

17.1 When specified by the purchaser at the time of placing the contract or order, each bar or profile 0.500 in. or greater in thickness or smallest dimension, in alloys 2014, 2024, 2219, and 7075 shall be tested ultrasonically in accordance with Practice B594 to the discontinuity acceptance limits of Table 3.

## 18. Source Inspection

18.1 If the purchaser desires that his representative inspect or witness the inspection and testing of the material prior to shipment, such agreement shall be made by the purchaser and the producer or supplier as part of the purchase contract.

18.2 When such inspection or witness of inspection and testing is agreed upon, the producer or supplier shall afford the purchaser's representative all reasonable facilities to satisfy him that the material meets the requirements of this specification. Inspection and tests shall be conducted so there is no unnecessary interference with the producer's or supplier's operations.

## 19. Retest and Rejection

19.1 If any material fails to conform to all of the applicable requirements of this specification, it shall be cause for rejection of the inspection lot.

19.2 When there is evidence that a failed specimen was not representative of the inspection lot and when no other sampling plan is provided or approved by the purchaser through the contract or purchase order, at least two additional specimens shall be selected to replace each test specimen that failed. All specimens so selected for retest shall meet the requirements of the specification or the lot shall be subject to rejection.

19.3 Material in which defects are discovered subsequent to inspection may be rejected.

19.4 If material is rejected by the purchaser, the producer or supplier is responsible only for replacement of the material to the purchaser. As much of the rejected material as possible shall be returned to the producer or supplier by the purchaser.

## 20. Identification Marking of Product

20.1 When specified in the contract or purchase order, all material shall be marked in accordance with Practice B666/B666M.

NOTE 9—Ordering in accordance with Practice B666/B666M will require the supplier to mark the lot number on each extruded section.

20.2 The requirements specified in 20.1 are minimum; marking systems that involve added information, larger characters, and greater frequencies are acceptable under this specification and shall be agreed upon between the producer and purchaser.

## 21. Packaging and Package Marking

21.1 The material shall be packaged to provide adequate protection during normal handling and transportation and each package shall contain only one size, alloy, and temper of material unless otherwise agreed upon. The type of packing and gross weight of containers shall, unless otherwise agreed upon, be at the producer or supplier's discretion, provided they are such as to ensure acceptance by common or other carriers for safe transportation at the lowest rate to the delivery point.

21.2 Each shipping container shall be marked with the purchase order number, material size, specification number, alloy and temper, gross and net weights, and the producer's name or trademark.

21.3 When specified in the contract or purchase order, material shall be preserved, packaged, and packed in accordance with the requirements of Practices B660. The applicable level shall be as specified in the contract or order. Marking for

shipment of such material shall be in accordance with Fed. Std. No. 123 for civil agencies and MIL-STD-129 for Military agencies.

## 22. Certification

22.1 The producer or supplier shall, on request, furnish to the purchaser a certificate stating that each lot has been sampled, tested, and inspected in accordance with this specification and has met the requirements.

## 23. Keywords

23.1 aluminum alloy; extruded bars; extruded profiles; extruded rods; extruded tubes; extruded wire

## ANNEXES

### (Mandatory Information)

#### A1. BASIS FOR INCLUSION OF PROPERTY LIMITS

A1.1 Limits are established at a level at which a statistical evaluation of the data indicates that 99 % of the population obtained from all standard material meets the limit with 95 % confidence. For the products described, mechanical property limits for the respective size ranges are based on the analyses of at least 100 data from standard production material with no more than ten data from a given lot. All tests are performed in accordance with the appropriate ASTM test methods. For informational purposes, refer to "Statistical Aspects of Mechanical Property Assurance" in the Related Material section of the Annual Book of ASTM Standards, Vol 02.02.

A1.2 Mechanical property limits are established in accord with Section 6, Standards Section, of the most current edition of the Aluminum Standards and Data and the latest edition of the Aluminum Association publication "Tempers for Aluminum and Aluminum Alloy Products (Yellow and Tan Sheets)."

A1.3 Limits are based on a statistical evaluation of the data indicating that at least 99 % of the population obtained from all standard material meets the limit with 95 % confidence. For the products described, mechanical property limits are based on the statistical analyses of at least 100 tests from at least 5 cast

lots of standard production material with no more than 10 observations from a given heat treat or inspection lot. Mechanical properties limits for press solution heat treated products have specific additional requirements which are provided in the "Tempers for Aluminum and Aluminum Alloy Products."

A1.4 Limits denoted as "Tentative" by the Aluminum Association may be included. Requirements for tentative property registrations are defined in the latest edition of the Aluminum Association publication "Tempers for Aluminum and Aluminum Alloy Products". Tentative property limits are established at levels at which at least 99 % of the data conform at a confidence level of 95 %. Tentative property limits, which are subject to revision, shall be based on a statistical analysis of at least 30 tests from at least 3 cast lots of standard production material with no more than 10 observations from a given heat treat or inspection lot. Where tentative property limits are listed, they shall be shown in italics and footnoted as Tentative in the standard.

A1.5 All tests are performed in accordance with the appropriate ASTM test methods.

## A2. ACCEPTANCE CRITERIA FOR INCLUSION OF NEW ALUMINUM AND ALUMINUM ALLOYS IN SPECIFICATION B221

A2.1 Prior to acceptance for inclusion in this specification, the composition of wrought or cast aluminum or aluminum alloy shall be registered in accordance with ANSI H35.1/H35.1M. The Aluminum Association<sup>4</sup> holds the Secretariat of ANSI H35 Committee and administers the criteria and procedures for registration.

A2.2 If it is documented that the Aluminum Association could not or would not register a given composition, an alternative procedure and the criteria for acceptance shall be as follows:

A2.2.1 The designation submitted for inclusion does not utilize the same designation system as described in ANSI H35.1/H35.1M. A designation not in conflict with other designation systems or a trade name is acceptable.

A2.2.2 The aluminum or aluminum alloy has been offered for sale in commercial quantities within the prior twelve months to at least three identifiable users.

A2.2.3 The complete chemical composition limits are submitted.

A2.2.4 The composition is, in the judgment of the responsible subcommittee, significantly different from that of any other aluminum or aluminum alloy already in the specification.

A2.2.5 For codification purposes, an alloying element is any element intentionally added for any purpose other than grain

refinement and for which minimum and maximum limits are specified. Unalloyed aluminum contains a minimum of 99.00 % aluminum.

A2.2.6 Standard limits for alloying elements and impurities are expressed to the following decimal places:

Less than 0.001 %	0.000X
0.001 to but less than 0.01 %	0.00X
0.01 to but less than 0.10 %	
Unalloyed aluminum made by a refining process	0.0XX
Alloys and unalloyed aluminum not made by a refining process 0.10 through 0.55 %	0.0X
(It is customary to express limits of 0.30 through 0.55 % as 0.X0 or 0.X5.)	0.XX
Over 0.55 %	0.X, X.X, and so forth

(except that combined Si + Fe limits for 99.00 % minimum aluminum must be expressed as 0.XX or 1.XX)

A2.2.7 Standard limits for alloying elements and impurities are expressed in the following sequence: Silicon; Iron; Copper; Manganese; Magnesium; Chromium; Nickel; Zinc (Note A2.1); Titanium; Other Elements, Each; Other Elements, Total; Aluminum (Note A2.2).

NOTE A2.1—Additional specified elements having limits are inserted in alphabetical order of their chemical symbols between titanium and other elements, each, or are specified in footnotes.

NOTE A2.2—Aluminum is specified as *minimum* for unalloyed aluminum and as a *remainder* for aluminum alloys.

## APPENDIX

(Nonmandatory Information)

### X1. DESIGNATIONS FOR METALS AND ALLOYS FORMERLY ASSIGNED IN CONFORMANCE WITH SPECIFICATION B221

X1.1 Designations assigned in conformance with this practice were used for wrought aluminum and wrought aluminum alloys in ASTM specifications prior to 1960, and for cast aluminum and aluminum alloys and ingot prior to 1974, but now designations conforming to the American National Standard Alloys and Temper Designation Systems for Aluminum

(ANSI H35.1/H35.1M) are standard with the UNS, Practice E527 for information only. The former ASTM designations and the corresponding ANSI and UNS designations for wrought alloys are as shown in Table X3.1. Cast alloys and ingot are as shown in Table X3.2. (See Table X1.1.)

TABLE X1.1 Wrought Aluminum Alloys

Designations					
ANSI H35.1/H35.1M	Former B275 – 63	UNS	ANSI H35.1/H35.1M	Former B275 – 63	UNS
1060	996A	A91060	5056	GM50A	A95056
1100	990A	A91100	5083	GM41A	A95083
2011	CB60A	A92011	5086	GM40A	A95086
2014	CS41A	A92014	5154	GR40A	A95154
2017	CM41A	A92017	5254	GR40B	A95254
2018	CN42C	A92018	5454	GM31A	A95454
2024	CG42A	A92024	5456	GM51A	A95456
2117	CG30A	A92117	5652	GR20B	A95652
3003	M1A	A93003	6053	GS11B	A96053
3004	MG11A	A93004	6061	GS11A	A96061
4032	SG121A	A94032	6063	GS10A	A96063
5005	G1B	A95005	6101	GS10B	A96101
5050	G1A	A95050	7075	ZG62A	A97075
5052	GR20A	A95052			

SUMMARY OF CHANGES

Committee B07 has identified the location of selected changes to this standard since the last issue (B221 – 20) that may impact the use of this standard. (Approved Sept. 1, 2021.)

- (1) Re-labelled footnote V of Table 1 as Note 4, in order to be in sequence with other notes, updated verbiage in accordance with standardized, and renumbered subsequent notes.
- (2) Removed footnotes I, J, and K from Table 2.
- (3) Changed footnote H to C in Table 2, and re-labelled subsequent footnotes.
- (4) Added footnote F to all stress-relieved tempers (T3510, T3511, T4510, T4511, T5510, T5511, T6510, T6511, T73510, T73511, T76510, T76511, T8510, T8511) for alloys 6013, 6020, 6064, 6066, and 6082.
- (5) Added footnote I to Table 2 and applied footnote to Alloy 5456 Extruded Tube tempers. Change replaces footnote H for those tempers, which was incorrectly applied in the previous revision.

- (6) Revised Note 5 (previously Note 4).
- (7) Revised 9.1 in accordance with standardized language.
- (8) Modified 12.1.2 to state that surveillance tests should be conducted IAW 12.2.
- (9) Updated Annex A1 in accordance with standardized language.
- (10) Updated Summary of changes.

*ASTM International takes no position respecting the validity of any patent rights asserted in connection with any item mentioned in this standard. Users of this standard are expressly advised that determination of the validity of any such patent rights, and the risk of infringement of such rights, are entirely their own responsibility.*

*This standard is subject to revision at any time by the responsible technical committee and must be reviewed every five years and if not revised, either reapproved or withdrawn. Your comments are invited either for revision of this standard or for additional standards and should be addressed to ASTM International Headquarters. Your comments will receive careful consideration at a meeting of the responsible technical committee, which you may attend. If you feel that your comments have not received a fair hearing you should make your views known to the ASTM Committee on Standards, at the address shown below.*

*This standard is copyrighted by ASTM International, 100 Barr Harbor Drive, PO Box C700, West Conshohocken, PA 19428-2959, United States. Individual reprints (single or multiple copies) of this standard may be obtained by contacting ASTM at the above address or at 610-832-9585 (phone), 610-832-9555 (fax), or service@astm.org (e-mail); or through the ASTM website (www.astm.org). Permission rights to photocopy the standard may also be secured from the Copyright Clearance Center, 222 Rosewood Drive, Danvers, MA 01923, Tel: (978) 646-2600; http://www.copyright.com/*

## SPECIFICATION FOR ALUMINUM AND ALUMINUM-ALLOY EXTRUDED BARS, RODS, WIRE, PROFILES, AND TUBES (METRIC)



**SB-221M**



(25)

(Identical with ASTM Specification B221M-21 except para. 1.1 has been revised to forbid the use of pipe, tube, and any hollow profile in pressure-retaining applications, and certification and test reports have been made mandatory.)

*ASME SB-221M replaces para. 1.1 and related Note 3, para. 4.2.5, and para. 22.1 of ASTM B221M with the following:*

1.1 This specification covers aluminum and aluminum-alloy extruded bars, rods, wires, profiles, and tubes in the aluminum alloys (Note 1) and tempers shown in Table 2. Pipe, tube, and any hollow profile produced in accordance with Specification B221M shall not be used in pressure-retaining applications.

NOTE 3 — Pipe and tube products listed in this specification are intended for general purpose applications. See Specification B210/B210M, B241/B241M, or both as appropriate for seamless pipe and tube used in fluid-carrying applications involving pressure. See Specification B234M, as appropriate, for use in surface condensers, evaporators, and heat exchangers.

4.2.5 DELETED

22.1 The producer or supplier shall furnish to the purchaser a certificate stating that each lot has been sampled, tested, and inspected in accordance with this specification and has met the requirements. A report of test results shall be furnished.



Designation: B221M – 21

## Standard Specification for Aluminum and Aluminum-Alloy Extruded Bars, Rods, Wire, Profiles, and Tubes (Metric)<sup>1</sup>

This standard is issued under the fixed designation B221M; the number immediately following the designation indicates the year of original adoption or, in the case of revision, the year of last revision. A number in parentheses indicates the year of last reapproval. A superscript epsilon ( $\epsilon$ ) indicates an editorial change since the last revision or reapproval.

*This standard has been approved for use by agencies of the U.S. Department of Defense.*

### 1. Scope\*

1.1 This specification covers aluminum and aluminum-alloy extruded bars, rods, wires, profiles, and tubes in the aluminum alloys (Note 1) and tempers shown in Table 2.

NOTE 1—Throughout this specification the use of the term *alloy* in the general sense includes aluminum as well as aluminum alloy.

NOTE 2—For rolled or cold-finished bars and rods refer to Specification B211/B211M, for drawn seamless tube used in pressure applications, Specification B210/B210M, for structural pipe and tube, Specification B429/B429M, and for seamless pipe and tube used in pressure applications, Specification B241/B241M.

NOTE 3—Pipe and tube products listed in this specification are intended for general purpose applications. This specification may not address the manufacturing processes, integrity testing, and verification required for fluid-carrying applications involving pressure. See Specification B210/B210M, B241/B241M, or both as appropriate for seamless pipe and tube used in fluid-carrying applications involving pressure. See Specification B234M, as appropriate, for use in surface condensers, evaporators, and heat exchangers.

1.2 Alloy and temper designations are in accordance with ANSI H35.1/H35.1M. The equivalent Unified Numbering System alloy designations are those of Table 1 preceded by A9, for example, A91100 for Aluminum 1100 in accordance with Practice E527.

1.3 For acceptance criteria for inclusion of new aluminum and aluminum alloys in this specification, see Annex A2.

1.4 This specification is the metric counterpart of Specification B221.

1.5 The values stated in SI are to be regarded as standard. No other units of measurement are included in this specification.

1.6 *This international standard was developed in accordance with internationally recognized principles on standardization established in the Decision on Principles for the Development of International Standards, Guides and Recom-*

<sup>1</sup> This specification is under the jurisdiction of ASTM Committee B07 on Light Metals and Alloys and is the direct responsibility of Subcommittee B07.03 on Aluminum Alloy Wrought Products.

Current edition approved Sept. 1, 2021. Published November 2021. Originally approved in 1979. Last previous edition approved in 2013 as B221M – 13. DOI: 10.1520/B0221M-21.

*mendations issued by the World Trade Organization Technical Barriers to Trade (TBT) Committee.*

### 2. Referenced Documents

2.1 The following documents of the issue in effect on the date of material purchase form a part of this specification to the extent referenced herein:

2.2 *ASTM Standards:*<sup>2</sup>

- B210/B210M Specification for Aluminum and Aluminum-Alloy Drawn Seamless Tubes
- B211/B211M Specification for Aluminum and Aluminum-Alloy Rolled or Cold Finished Bar, Rod, and Wire
- B234M Specification for Aluminum and Aluminum-Alloy Drawn Seamless Tubes for Surface Condensers, Evaporators, and Heat Exchangers (Metric)
- B241/B241M Specification for Aluminum and Aluminum-Alloy Seamless Pipe and Seamless Extruded Tube
- B429/B429M Specification for Aluminum-Alloy Extruded Structural Pipe and Tube
- B557M Test Methods for Tension Testing Wrought and Cast Aluminum- and Magnesium-Alloy Products (Metric)
- B594 Practice for Ultrasonic Inspection of Aluminum-Alloy Wrought Products
- B660 Practices for Packaging/Packing of Aluminum and Magnesium Products
- B666/B666M Practice for Identification Marking of Aluminum and Magnesium Products
- B807/B807M Practice for Extrusion Press Solution Heat Treatment for Aluminum Alloys
- B881 Terminology Relating to Aluminum- and Magnesium-Alloy Products
- B918/B918M Practice for Heat Treatment of Wrought Aluminum Alloys
- B945 Practice for Aluminum Alloy Extrusions Press Cooled from an Elevated Temperature Shaping Process for Production of T1, T2, T5 and T10-Type Tempers

<sup>2</sup> For referenced ASTM standards, visit the ASTM website, [www.astm.org](http://www.astm.org), or contact ASTM Customer Service at [service@astm.org](mailto:service@astm.org). For *Annual Book of ASTM Standards* volume information, refer to the standard's Document Summary page on the ASTM website.

TABLE 1 Chemical Composition Limits<sup>A,B,C</sup>

Alloy	Silicon	Iron	Copper	Manga- nese	Magne- sium	Chromium	Zinc	Titanium	Vanadium	Other Elements <sup>D</sup>		Aluminum
										Each	Total <sup>E</sup>	
1060	0.25	0.35	0.05	0.03	0.03	...	0.05	0.03	0.05	0.03	...	99.60 min <sup>F</sup>
1100 <sup>G</sup>	0.95 Si + Fe		0.05–0.20	0.05	...	...	0.10	...	...	0.05	0.15	99.00 min <sup>F</sup>
2014 <sup>H</sup>	0.50–1.2	0.7	3.9–5.0	0.40–1.2	0.20–0.8	0.10	0.25	0.15	...	0.05	0.15	rem
2024 <sup>H</sup>	0.50	0.50	3.8–4.9	0.30–0.9	1.2–1.8	0.10	0.25	0.15	...	0.05	0.15	rem
2219 <sup>I</sup>	0.20	0.30	5.8–6.8	0.20–0.40	0.02	...	0.10	0.02–0.10	0.05–0.15	0.05	0.15	rem
3003	0.6	0.7	0.05–0.20	1.0–1.5	...	...	0.10	...	...	0.05	0.15	rem
Alclad 3003	...	3003 Clad with 7072 Alloy		...	...	...	...	...	...	...	...	...
3004	0.30	0.7	0.25	1.0–1.5	0.8–1.3	...	0.25	...	...	0.05	0.15	rem
3102	0.40	0.7	0.10	0.05–0.40	...	...	0.30	0.10	...	0.05	0.15	rem
5052	0.25	0.40	0.10	0.10	2.2–2.8	0.15–0.35	0.10	...	...	0.05	0.15	rem
5083	0.40	0.40	0.10	0.40–1.0	4.0–4.9	0.05–0.25	0.25	0.15	...	0.05	0.15	rem
5086	0.40	0.50	0.10	0.20–0.7	3.5–4.5	0.05–0.25	0.25	0.15	...	0.05	0.15	rem
5154 <sup>G</sup>	0.25	0.40	0.10	0.10	3.1–3.9	0.15–0.35	0.20	0.20	...	0.05	0.15	rem
5454	0.25	0.40	0.10	0.50–1.0	2.4–3.0	0.05–0.20	0.25	0.20	...	0.05	0.15	rem
5456	0.25	0.40	0.10	0.50–1.0	4.7–5.5	0.05–0.20	0.25	0.20	...	0.05	0.15	rem
6005	0.6–0.9	0.35	0.10	0.10	0.40–0.6	0.10	0.10	0.10	...	0.05	0.15	rem
6005A <sup>J</sup>	0.50–0.9	0.35	0.30	0.50	0.40–0.7	0.30	0.20	0.10	...	0.05	0.15	rem
6013	0.6–1.0	0.50	0.6–1.1	0.20–0.8	0.8–1.2	0.10	0.25	0.10	...	0.05	0.15	rem
6020 <sup>K</sup>	0.40–0.9	0.50	0.30–0.9	0.35	0.6–1.2	0.15	0.20	0.15	...	0.05	0.15	rem
6026 <sup>L</sup>	0.6–1.4	0.7	0.20–0.50	0.20–1.0	0.6–1.2	0.30	0.30	0.20	...	0.05	0.15	rem
6041 <sup>M</sup>	0.50–0.9	0.15–0.7	0.15–0.6	0.05–0.20	0.8–1.2	0.05–0.15	0.25	0.15	...	0.05	0.15	rem
6042 <sup>N</sup>	0.50–1.2	0.7	0.20–0.6	0.40	0.7–1.2	0.04–0.35	0.25	0.15	...	0.05	0.15	rem
6060	0.30–0.6	0.10–0.30	0.10	0.10	0.35–0.6	0.05	0.15	0.10	...	0.05	0.15	rem
6061 <sup>O</sup>	0.40–0.8	0.7	0.15–0.40	0.15	0.8–1.2	0.04–0.35	0.25	0.15	...	0.05	0.15	rem
6063	0.20–0.6	0.35	0.10	0.10	0.45–0.9	0.10	0.10	0.10	...	0.05	0.15	rem
6064 <sup>P</sup>	0.40–0.8	0.7	0.15–0.40	0.15	0.8–1.2	0.05–0.14	0.25	0.15	...	0.05	0.15	rem
6066	0.9–1.8	0.50	0.7–1.2	0.6–1.1	0.8–1.4	0.40	0.25	0.20	...	0.05	0.15	rem
6070	1.0–1.7	0.50	0.15–0.40	0.40–1.0	0.50–1.2	0.10	0.25	0.15	...	0.05	0.15	rem
6082	0.7–1.3	0.50	0.10	0.40–1.0	0.6–1.2	0.25	0.20	0.10	...	0.05	0.15	rem
6105	0.6–1.0	0.35	0.10	0.15	0.45–0.8	0.10	0.10	0.10	...	0.05	0.15	rem
6162	0.40–0.8	0.50	0.20	0.10	0.7–1.1	0.10	0.25	0.10	...	0.05	0.15	rem
6262 <sup>Q</sup>	0.40–0.8	0.7	0.15–0.40	0.15	0.8–1.2	0.04–0.14	0.25	0.15	...	0.05	0.15	rem
6351	0.7–1.3	0.50	0.10	0.40–0.8	0.40–0.8	...	0.20	0.20	...	0.05	0.15	rem
6360	0.35–0.8	0.10–0.30	0.15	0.02–0.15	0.25–0.45	0.05	0.10	0.10	...	0.05	0.15	rem
6463	0.20–0.6	0.15	0.20	0.05	0.45–0.9	...	0.05	...	...	0.05	0.15	rem
6560	0.30–0.7	0.10–0.30	0.05–0.20	0.20	0.20–0.6	0.05	0.15	0.10	...	0.05	0.15	rem
7005 <sup>R</sup>	0.35	0.40	0.10	0.20–0.7	1.0–1.8	0.06–0.20	4.0–5.0	0.01–0.06	...	0.05	0.15	rem
7072 <sup>S</sup>	0.7 Si + Fe		0.10	0.10	0.10	...	0.8–1.3	...	...	...	...	rem
7075 <sup>T</sup>	0.40	0.50	1.2–2.0	0.30	2.1–2.9	0.18–0.28	5.1–6.1	0.20	...	0.05	0.15	rem
7116 <sup>U</sup>	0.15	0.30	0.50–1.1	0.05	0.8–1.4	...	4.2–5.2	0.05	0.05	0.05	0.15	rem
7129 <sup>U</sup>	0.15	0.30	0.50–0.9	0.10	1.3–2.0	0.10	4.2–5.2	0.05	0.05	0.05	0.15	rem

<sup>A</sup> Limits are in weight percent maximum unless shown as a range, or stated otherwise.

<sup>B</sup> Analysis shall be made for the elements for which limits are shown in this table.

<sup>C</sup> For the purpose of determining conformance to these limits, an observed value or a calculated value obtained from analysis shall be rounded to the nearest unit in the last right-hand place of the figures used in expressing the specified limit, in accordance with the rounding-off method of Practice E29.

<sup>D</sup> *Others* includes listed elements for which no specific limit is shown as well as unlisted metallic elements. The producer may analyze samples for trace elements not specified in the specification. However, such analysis is not required and may not cover all metallic *Others* elements. Should any analysis by the producer or the purchaser establish that an *Others* element exceeds the limit of *Each* or that the aggregate of several *Others* elements exceeds the limit of *Total*, the material shall be considered nonconforming.

<sup>E</sup> *Other Elements*—Total shall be the sum of unspecified metallic elements 0.010 % or more, rounded to the second decimal before determining the sum.

<sup>F</sup> The aluminum content shall be calculated by subtracting from 100.00 % the sum of all metallic elements present in amounts of 0.010 % or more each, rounded to the second decimal before determining the sum.

<sup>G</sup> Be 0.0003 max for welding electrode, welding rod, and filler wire.

<sup>H</sup> Upon agreement between the purchaser and the producer or supplier, a Zr + Ti limit of 0.20 % max is permitted. Properties in Specification (Table 2) are not based on the Zirconium and Titanium algorithm.

<sup>I</sup> Zirconium, 0.10–0.25 %. The total for other elements does not include zirconium.

<sup>J</sup> Manganese plus chromium shall total 0.12–0.50.

<sup>K</sup> Lead 0.05 % max, Tin 0.9–1.5 %.

<sup>L</sup> Bismuth 0.50–1.5 %, Lead 0.4 % max, Tin 0.05 % max.

<sup>M</sup> Bismuth 0.30–0.9 %, Tin 0.35–1.2 %.

<sup>N</sup> Bismuth 0.20–0.8 % Lead 0.15–0.40 %.

<sup>O</sup> In 1965 the requirements for 6062 were combined with those for 6061 by revising the minimum chromium from "0.15 %" to "0.04 %." This action cancelled Alloy 6062.

<sup>P</sup> Bismuth 0.50–0.7 %, Lead 0.20–0.04 %.

<sup>Q</sup> Bismuth and lead shall be 0.40–0.7 % each.

<sup>R</sup> Zirconium 0.08–0.20 %. The total for other elements does not include zirconium.

<sup>S</sup> Composition of cladding alloy applied during the course of manufacture. Samples from finished tube shall not be required to conform to these limits.

<sup>T</sup> Upon agreement between the purchaser and the producer or supplier, a Zr + Ti limit of 0.25 % max is permitted. Properties in Specification (Table 2) are not based on the Zirconium and Titanium algorithm.

<sup>U</sup> Gallium 0.03 % max.

TABLE 2 Tensile Property Limits<sup>A,B</sup>

Temper	Product Type <sup>C</sup>	Specified Section or Wall Thickness, mm		Area, mm <sup>2</sup>		Tensile Strength, MPa		Yield Strength (0.2 %)		Elongation, <sup>D</sup> %, min	
		over	incl	over	incl	min	max	min	max	in 50 mm	in 50 × Diameter (5.56√A)
Aluminum 1060 <sup>E</sup>											
O	Extruded Tube	all		all		60	95	15	...	25	22
H112	Extruded Tube	all		all		60	...	15	...	25	22
Aluminum 1100 <sup>E</sup>											
O	Extruded Tube	all		all		75	105	20	...	25	22
H112	Extruded Tube	all		all		75	...	20	...	25	22
Alloy 2014 <sup>E</sup>											
O	Extruded Wire, Rod, Bar, Profiles, and Tube	all		all		...	205	...	125	12	10
T4 T4510 <sup>F</sup> T4511 <sup>F</sup>	Extruded Wire, Rod, Bar, Profiles, and Tube	all		all		345	...	240	...	12	10
T42 <sup>G</sup>		all		all		345	...	200	...	12	10
T6 T6510 <sup>F</sup> T6511 <sup>F</sup>		Extruded Wire, Rod, Bar, Profiles, and Tube	...	12.50	all		415	...	365	...	7
	12.50		18.00	all		440	...	400	...	...	6
	18.00		...	...	16 000	470	...	415	...	...	6
	18.00		...	16 000	20 000	470	...	400	...	...	5
T62 <sup>G</sup>	Extruded Wire, Rod, Bar, Profiles, and Tube	...	18.00	all		415	...	365	...	7	6
		18.00	...	...	16 000	415	...	365	...	...	6
		18.00	...	16 000	20 000	415	...	365	...	...	5
Alloy 2024 <sup>E</sup>											
O	Extruded Wire, Rod, Bar, and Profiles	all		all		...	240	...	130	12	10
T3 T3510 <sup>F</sup> T3511 <sup>F</sup>	Extruded Wire, Rod, Bar, and Profiles	...	6.30	all		395	...	290	...	12	...
		6.30	18.00	all		415	...	305	...	12	10
		18.00	35.00	all		450	...	315	...	...	9
		35.00	...	...	16 000	485	...	360	...	...	9
		35.00	...	16 000	20 000	470	...	330	...	...	7
T3 T3510 <sup>F</sup> T3511 <sup>F</sup>	Extruded Tube	...	6.30	all		395	...	290	...	10	...
		6.30	18.00	all		415	...	305	...	10	9
		18.00	35.00	all		450	...	315	...	...	9
		35.00	...	...	16 000	485	...	330	...	...	9
		35.00	...	16 000	20 000	470	...	315	...	...	7
T42 <sup>G</sup>	Extruded Wire, Rod, Bar, Profiles, and Tube	...	18.00	all		395	...	260	...	12	10
		18.00	35.00	all	...	395	...	260	...	...	9
		35.00	...	...	16 000	395	...	260	...	...	9
		35.00	...	16 000	20 000	395	...	260	...	...	7
T81 T8510 <sup>F</sup> T8511 <sup>F</sup>	Extruded Wire, Rod, Bar, Profiles, and Tube	1.20	6.30	all		440	...	385	...	4	...
		6.30	35.00	all		455	...	400	...	5	4
		35.00	...	...	20 000	455	...	400	...	...	4

TABLE 2 Continued

Temper	Product Type <sup>C</sup>	Specified Section or Wall Thickness, mm		Area, mm <sup>2</sup>		Tensile Strength, MPa		Yield Strength (0.2 %)		Elongation, <sup>D</sup> %, min	
		over	incl	over	incl	min	max	min	max	in 50 mm	in 50 × Diameter (5.56√A)
Alloy 2219 <sup>E</sup>											
O	Extruded Wire, Rod, Bar, Profiles, and Tube	all		all		...	220	...	125	12	10
T31 T3510 <sup>F</sup> T3511 <sup>F</sup>	Extruded Wire, Rod, Bar, Profiles, and Tube	...	12.50	...	16 000	290	...	180	...	14	12
			12.50	80.00	...	16 000	310	...	185	...	
T62 <sup>G</sup>	Extruded Wire, Rod, Bar, Profiles, and Tube	...	25.00	...	16 000	370	...	250	...	6	5
			25.00		...	20 000	370	...	250	...	
T81 T8510 <sup>F</sup> T8511 <sup>F</sup>	Extruded Wire, Rod, Bar, Profiles, and Tube	...	80.00	...	16 000	400	...	290	...	6	5
Alloy 3003 <sup>E</sup>											
O	Extruded Wire, Rod, Bar, Profiles, and Tube	all		all		95	130	35	...	25	22
H112	Extruded Wire, Rod, Bar, and Profiles	all		all		95	...	35	...	...	...
H112	Extruded Tube	all		all		95	...	35	...	25	22
Alclad Alloy 3003											
O	Extruded Tube	all		all		90	125	30	...	25	22
H112	Extruded Tube	all		all		90	...	30	...	25	22
Alloy 3004 <sup>E</sup>											
O	Extruded Tube	all		all		160	200	60	...	...	...
Alloy 3102											
H112	Extruded Tube	0.63	1.20	all		75	125	30	...	25	...
Alloy 5052 <sup>E</sup>											
O	Extruded Tube	all		all		170	240	70	...	...	...
Alloy 5083 <sup>E</sup>											
O	Extruded Wire, Rod, Bar, and Profiles	...	130.00	...	20 000	270	350	110	...	14	12
H111	Extruded Wire, Rod, Bar, and Profiles	...	130.00	...	20 000	275	...	165	...	12	10
H112	Extruded Wire, Rod, Bar, and Profiles	...	130.00	...	20 000	270	...	110	...	12	10
O	Extruded Tube		70 <sup>H</sup>	...	20 000	270	350	110	...	14	12
H111	Extruded Tube		70 <sup>H</sup>	...	20 000	275	...	165	...	12	10
H112	Extruded Tube		70 <sup>H</sup>	...	20 000	270	...	110	...	12	10
Alloy 5086 <sup>E</sup>											
O	Extruded Wire, Rod, Bar, and Profiles	...	130.00	...	20 000	240	315	95	...	14	12
H111	Extruded Wire, Rod, Bar, and Profiles	...	130.00	...	20 000	250	...	145	...	12	10
H112	Extruded Wire, Rod, Bar, and Profiles	...	130.00	...	20 000	240	...	95	...	12	10
O	Extruded Tube		70 <sup>H</sup>	...	20 000	240	315	95	...	14	12
H111	Extruded Tube		70 <sup>H</sup>	...	20 000	250	...	145	...	12	10
H112	Extruded Tube		70 <sup>H</sup>	...	20 000	240	...	95	...	12	10

ASME BPVC.II.B (ASME BPVC Section II part B) 2025  
 ASMENORMDOC.COM · Click to view the full PDF of ASME BPVC.II.B (ASME BPVC Section II part B) 2025

TABLE 2 Continued

Temper	Product Type <sup>C</sup>	Specified Section or Wall Thickness, mm		Area, mm <sup>2</sup>		Tensile Strength, MPa		Yield Strength (0.2 %)		Elongation, <sup>D</sup> % min	
		over	incl	over	incl	min	max	min	max	in 50 mm	in 50 x Diameter (5.56√A)
Alloy 5154											
O	Extruded Wire, Rod, Bar, Profiles, and Tube	all		all		205	285	75	...	...	...
H112	Extruded Wire, Rod, Bar, Profiles, and Tube	all		all		205	...	75	...	...	...
Alloy 5454 <sup>E</sup>											
O	Extruded Wire, Rod, Bar, and Profiles	...	130.00	...	20 000	215	285	85	...	14	12
H111	Extruded Wire, Rod, Bar, and Profiles	...	130.00	...	20 000	230	...	130	...	12	10
H112	Extruded Wire, Rod, Bar, and Profiles	...	130.00	...	20 000	215	...	85	...	12	10
O	Extruded Tube		70 <sup>H</sup>		20 000	215	285	85	...	14	12
H111	Extruded Tube		70 <sup>H</sup>		20 000	230	...	130	...	12	10
H112	Extruded Tube		70 <sup>H</sup>		20 000	215	...	85	...	12	10
Alloy 5456 <sup>E</sup>											
O	Extruded Wire, Rod, Bar, and Profiles	...	120.00	...	20 000	285	365	130	...	14	12
H111	Extruded Wire, Rod, Bar, and Profiles	...	120.00	...	20 000	290	...	180	...	12	10
H112	Extruded Wire, Rod, Bar, and Profiles	...	120.00	...	20 000	285	...	130	...	12	10
O	Extruded Tube		70 <sup>I</sup>		20 000	285	365	130	...	14	12
H111	Extruded Tube		70 <sup>I</sup>		20 000	290	...	180	...	12	10
H112	Extruded Tube		70 <sup>I</sup>		20 000	285	...	130	...	12	10
Alloy 6005											
T1	Extruded Wire, Rod, Bar, Profiles, and Tube	...	12.50	all		170	...	105	...	16	14
T5	Extruded Wire, Rod, Bar, Profiles, and Tube	3.20	3.20	all		260	...	240	...	8	...
			25.00	all		260	...	240	...	10	9
Alloy 6005A											
T1	Extruded Wire, Rod, Bar, Profiles, and Tube	...	6.30	all		170	...	100	...	15	...
T5	Extruded Wire, Rod, Bar, Profiles, and Tube	6.30	6.30	all		260	...	215	...	7	...
			25.00	all		260	...	215	...	9	8
T61	Extruded Wire, Rod, Bar, Profiles, and Tube	6.30	6.30	all		260	...	240	...	8	...
			25.00	all		260	...	240	...	10	9
Alloy 6013											
T6, T6511 <sup>F</sup>	Extrusion, Rod, and Seamless Tube	5.00	12.50	all		340	...	315	...	8	...
		12.50	20.00	all		340	...	315	...	...	7
		20.00	50.00	all		340	...	310	...	...	7
Alloy 6020											
T6511 <sup>F</sup>	Extruded Rod and Bar	80.00	160.00	all		260	...	240	...	...	9

TABLE 2 Continued

Temper	Product Type <sup>C</sup>	Specified Section or Wall Thickness, mm		Area, mm <sup>2</sup>		Tensile Strength, MPa		Yield Strength (0.2 %)		Elongation, <sup>D</sup> % min	
		over	incl	over	incl	min	max	min	max	in 50 mm	in 50 × Diameter (5.56√A)
Alloy 6026											
T6, T6510, <sup>F</sup> T6511 <sup>F</sup>	Extruded Profiles	5.00	40.00	all		340	...	260	...	6	8
T6, T6510, <sup>F</sup> T6511 <sup>F</sup>	Extruded Tube	10.00	30.00	all		340	...	260	...	6	8
T6, T6510, <sup>F</sup> T6511 <sup>F</sup>	Extruded Bar, Rod, and Wire	30.00	140.00	all		370	...	300	...	6	8
		140.00	200.00	all		340	...	250	...	6	8
		200.00	250.00	all		300	...	200	...	6	8
Alloy 6041											
T6, T6511 <sup>F</sup>	Extruded Rod, Bar, and Profiles	10.00	50.00	all		310	...	275	...	10	9
Alloy 6042											
T5, T5511 <sup>F</sup>	Extruded Rod, Bar, and Profiles	10.00	12.50	all		260	...	240	...	10	...
		12.50	50.00	all		260	...	240	...	...	9
Alloy 6060											
T51	Extruded Profiles	...	3.20	all		150	...	110	...	8	...
T61	Extruded Profiles	...	3.20	all		205	...	170	...	8	...
		3.20	25.00	all		205	...	170	...	10	9
Alloy 6061 <sup>E</sup>											
O	Extruded Wire, Rod, Bar, Profiles, and Tube	all		all		...	150	...	110	16	14
T1	Extruded Wire, Rod, Bar, Profiles, and Tube	...	16.00	all		180	...	95	...	16	14
T4, T4510, <sup>F</sup> T4511 <sup>F</sup>	Extruded Wire, Rod, Bar Profiles, and Tube	all		all		180	...	110	...	16	14
		all		all		180	...	110	...	16	14
T42 <sup>G</sup>	Extruded Wire, Rod, Bar, Profiles, and Tube	all		all		180	...	85	...	16	14
T51	Extruded Wire, Rod, Bar, Profiles, and Tube	...	16.00	all		240	...	205	...	8	7
T6, T62, <sup>G</sup> T6510, <sup>F</sup> T6511 <sup>F</sup>	Extruded Wire, Rod, Bar, Profiles, and Tube	...	6.30	all		260	...	240	...	8	...
		6.30	...	all		260	...	240	...	10	9
Alloy 6063											
O	Extruded Wire, Rod, Bar, Profiles, and Tube	all		all		...	130	...	...	18	16
T1	Extruded Wire, Rod, Bar, Profiles, and Tube	...	12.50	all		115	...	60	...	12	10
		12.50	25.00	all		110	...	55	...	...	10
T4, T42 <sup>G</sup>	Extruded Wire, Rod, Bar, Profiles, and Tube	...	12.50	all		130	...	70	...	14	12
		12.50	25.00	all		125	...	60	...	...	12
T5	Extruded Wire, Rod, Bar, Profiles, and Tube	...	12.50	all		150	...	110	...	8	7
		12.50	25.00	all		145	...	105	...	...	7
T52	Extruded Wire, Rod, Bar, Profiles, and Tube	...	25.00	all		150	205	110	170	8	7
T54	Extruded Wire, Rod, Bar, and Profiles	...	3.20	all		225	...	205	...	8	...
		3.20	12.50	all		225	...	205	...	10	...

TABLE 2 Continued

Temper	Product Type <sup>C</sup>	Specified Section or Wall Thickness, mm		Area, mm <sup>2</sup>		Tensile Strength, MPa		Yield Strength (0.2 %)		Elongation, <sup>D</sup> %, min												
		over	incl	over	incl	min	max	min	max	in 50 mm	in 50 x Diameter (5.56√A)											
Alloy 6063 (Continued)																						
T6, T62 <sup>G</sup>	Extruded Wire, Rod, Bar, Profiles, and Tube	...	3.20 25.0	all	all	205 205	...	170 170	...	8 10	...											
T65	Extruded Wire, Rod, Bar, and Profiles	...	5.00	all		250	...	230	...	7												
Alloy 6064																						
T6	Extruded Wire, Rod, Bar, and Profiles	5.00	80.00	all		290	...	260	...	10	9											
T6511 <sup>F</sup>	Extruded Wire, Rod, Bar, and Profiles	5.00	80.00	all		290	...	260	...	10	9											
Alloy 6066																						
O	Extruded Wire, Rod, Bar, Profiles, and Tube	all		all		...	200	...	125	16	14											
T4, T4510, <sup>F</sup> T4511 <sup>F</sup>	Extruded Wire, Rod, Bar, Profiles, and Tube	all		all		275	...	170	...	14	12											
T42 <sup>G</sup>												Extruded Wire, Rod, Bar, Profiles, and Tube	all		all		275	...	165	...	14	12
T6, T6510, <sup>F</sup> T6511 <sup>F</sup>	Extruded Wire, Rod, Bar, Profiles, and Tube	all		all		345	...	310	...	8	7											
T62 <sup>G</sup>												Extruded Wire, Rod, Bar, Profiles, and Tube	all		all		345	...	290	...	8	7
Alloy 6070																						
T6, T62 <sup>G</sup>	Extruded Wire, Rod, Bar, Profiles, and Tube	...	80.00	...	20 000	330	...	310	...	6	5											
Alloy 6082																						
T6, T6511 <sup>F</sup>	Extruded Wire, Rod, Bar, and Profiles	5.00 20.00 150.00	20.00 150.00 200.00	all all all		310 310 280	...	260 260 240	...	6 8 8	8 8 8											
T6												Extruded Tube	5.00	25.00	all		310	...	260	...	8	10
Alloy 6105																						
T1	Extruded Wire, Rod, Bar, Profiles, and Tube	...	12.50	all		170	...	105	...	16	14											
T5	Extruded Wire, Rod, Bar, Profiles, and Tube	...	12.50	all		260	...	240	...	8	7											
T6	Extruded Wire, Rod, Bar, and Profiles	...	12.50	all		260	...	240	...	8	7											
Alloy 6162																						
T5, T5510, <sup>F</sup> T5511 <sup>F</sup>	Extruded Wire, Rod, Bar, Profiles, and Tube	...	25.00	all		255	...	235	...	7	6											
T6, T6510, <sup>F</sup> T6511 <sup>F</sup>	Extruded Wire, Rod, Bar, Profiles, and Tube	...	6.30 12.50	all all		260 260	...	240 240	...	8 10	...											
Alloy 6262																						
T6, T62, <sup>G</sup> T6510, <sup>F</sup> T6511 <sup>F</sup>	Extruded Wire, Rod, Bar, Profiles and Tube	all		all		260	...	240	...	10	9											

TABLE 2 Continued

Temper	Product Type <sup>C</sup>	Specified Section or Wall Thickness, mm		Area, mm <sup>2</sup>		Tensile Strength, MPa		Yield Strength (0.2%)		Elongation, <sup>D</sup> %, min	
		over	incl	over	incl	min	max	min	max	in 50 mm	in 50 × Diameter (5.56√A)
Alloy 6351											
T1	Extruded Wire, Rod, Bar, and Profiles	...	12.50	...	13 000	180	...	90	...	15	13
T11	Extruded Wire, Rod, Bar, and Profiles	...	20.00	all		180	...	110	...	16	14
T4	Extruded Wire, Rod, Bar, Profiles, and Tube	...	20.00	all		220	...	130	...	16	14
T5	Extruded Wire, Rod, Bar, and Profiles	...	6.30	all		260	...	240	...	8	...
		6.30	25.00	all		260	...	240	...	10	9
T51	Extruded Wire, Rod, Bar, and Profiles	3.20	25.00	...	13 000	250	...	230	...	10	7
T54	Extruded Wire, Rod, Bar, and Profiles	...	12.50	...	13 000	205	...	140	...	10	9
T6	Extruded Wire, Rod, Bar, Profiles, and Tube	...	3.20	all		290	...	255	...	8	...
		3.20	20.00	all		290	...	255	...	10	9
Alloy 6360											
T5	Extruded Wire, Rod, Bar, Profiles and Tube	...	6.30	all		150	...	110	...	8	...
T6	Extruded Wire, Rod, Bar, Profiles, and Tube	...	3.20	all		205	...	170	...	8	...
		3.20	6.30	all		205	...	170	...	10	...
Alloy 6463											
T1	Extruded Wire, Rod, Bar, and Profiles	...	12.50	...	13 000	115	...	60	...	12	10
T5	Extruded Wire, Rod, Bar, and Profiles	...	12.50	...	13 000	150	...	110	...	8	7
T6, T62 <sup>G</sup>	Extruded Wire, Rod, Bar, and Profiles	...	3.20	...	13 000	205	...	170	...	8	...
		3.20	12.50	...	13 000	205	...	170	...	10	9
Alloy 6560											
T5	Extruded Wire, Rod, Bar, Profiles, and Tube	2.50	3.20	all		150	...	110	...	8	...
T6	Extruded Wire, Rod, Bar, Profiles, and Tube	2.50	3.20	all		205	...	170	...	8	...
Alloy 7005											
T53	Extruded Wire, Rod, Bar, and Profiles		20.00	all		345	...	305	...	10	9
Alloy 7075 <sup>E</sup>											
T6	Extruded Wire, Rod, Bar, and Profiles	all		all		...	275	...	165	10	9
T62 <sup>G</sup> T6510 <sup>F</sup> T6511 <sup>F</sup>		...	6.30	all		540	...	485	...	7	...
		6.30	12.50	all		560	...	505	...	7	6
		12.50	70.00	all		560	...	495	...	...	6
		70.00	110.00	...	13 000	560	...	490	...	...	6
		70.00	110.00	...	13 000	540	...	485	...	...	5
110.00	130.00	...	20 000	540	...	470	...	...	5		

TABLE 2 Continued

Temper	Product Type <sup>C</sup>	Specified Section or Wall Thickness, mm		Area, mm <sup>2</sup>		Tensile Strength, MPa		Yield Strength (0.2%)		Elongation, <sup>D</sup> %, min	
		over	incl	over	incl	min	max	min	max	in 50 mm	in 50 × Diameter (5.56√A)
Alloy 7075 <sup>E</sup> (Continued)											
T6 T62 <sup>G</sup> T6510 <sup>F</sup> T6511 <sup>F</sup>	Extruded Tube	...	6.30	all	...	540	...	485	...	7	...
		6.30	12.50	all	...	540	...	505	...	7	6
		12.50	70.00	all	...	560	...	495	...	...	6
T73 T73510 <sup>F</sup> T73511 <sup>F</sup>	Extruded Wire, Rod, Bar, and Profiles	1.60	6.30	...	13 000	470	...	400	...	7	...
		6.30	35.00	...	16 000	485	...	420	...	8	7
		35.00	70.00	...	16 000	475	...	405	...	...	7
		70.00	110.00	...	13 000	470	...	395	...	...	6
		70.00	110.00	13 000	20 000	450	...	380	...	...	6
T73 T73510 <sup>F</sup> T73511 <sup>F</sup>	Extruded Tube	1.60	6.30	all	...	470	...	400	...	7	...
		6.30	35.00	...	16 000	485	...	420	...	8	7
		35.00	70.00	...	16 000	475	...	405	...	...	7
T76 T76510 <sup>F</sup> T76511 <sup>F</sup>	Extruded Wire, Rod, Bar, and Profiles	...	1.25	all	...	500	...	435	...	7	...
		1.25	3.20	all	...	510	...	440	...	7	...
		3.20	6.30	...	13 000	510	...	440	...	7	...
		6.30	12.50	...	13 000	515	...	450	...	7	6
		12.50	25.00	...	13 000	515	...	450	...	...	6
		25.00	50.00	...	13 000	515	...	450	...	...	6
		50.00	75.00	...	13 000	510	...	440	...	...	6
		75.00	100.00	...	13 000	510	...	435	...	...	6
Alloy 7116											
T5	Extruded Wire, Rod, Bar, and Profiles	3.20	12.50	all	...	330	...	290	...	8	7
Alloy 7129											
T5, T6	Extruded Wire, Rod, Bar, and Profiles	...	12.50	all	...	380	...	340	...	9	8

<sup>A</sup> The basis for establishment of tensile property limits is shown in Annex A1.  
<sup>B</sup> To determine conformance to this specification, each value shall be rounded to the nearest 1 MPa for strength and the nearest 0.5 % for elongation, in accordance with the rounding-off method of Practice E29.  
<sup>C</sup> Product type as specified in by Aluminum Association Registrations found in Tan Sheets, and AS&D.  
<sup>D</sup> Elongations in 50 mm apply for shapes tested in full section and for sheet-type specimens machined from material up through 12.5 mm in thickness having parallel surfaces. Elongations in 5× diameter (5.65√A), where D and A are diameter and cross-sectional area of the specimen respectively, apply to round test specimens machined from thicknesses over 6.30. See 8.1.1 and 8.1.2 for conditions under which measurements are not required.  
<sup>E</sup> These alloys are also produced in the F temper for which no tensile properties are specified or guaranteed.  
<sup>F</sup> For stress-relieved tempers (T3510, T3511, T4510, T4511, T5510, T5511, T6510, T6511, T73510, T73511, T76510, T76511, T8510, T8511), characteristics and properties offer than those specified may differ somewhat from the corresponding characteristics and properties of material in the basic tempers.  
<sup>G</sup> Material in the T42 and T62 tempers is not available from the material producers.  
<sup>H</sup> Specified wall thickness range is limited to 70 mm. This differs from Aluminum Standards and Data, which specifies wall thickness range as "All."  
<sup>I</sup> Specified wall thickness range is limited to 70 mm. This differs from Aluminum Association Tan Sheets, which specifies wall thickness range as 120 mm for all extrusion products.

B985 Practice for Sampling Aluminum Ingots, Billets, Castings and Finished or Semi-Finished Wrought Aluminum Products for Compositional Analysis

E29 Practice for Using Significant Digits in Test Data to Determine Conformance with Specifications

E34 Test Methods for Chemical Analysis of Aluminum and Aluminum-Base Alloys (Withdrawn 2017)<sup>3</sup>

E527 Practice for Numbering Metals and Alloys in the Unified Numbering System (UNS)

E716 Practices for Sampling and Sample Preparation of Aluminum and Aluminum Alloys for Determination of Chemical Composition by Spark Atomic Emission Spectrometry

E1004 Test Method for Determining Electrical Conductivity Using the Electromagnetic (Eddy Current) Method

E1251 Test Method for Analysis of Aluminum and Aluminum Alloys by Spark Atomic Emission Spectrometry

E3061 Test Method for Analysis of Aluminum and Aluminum Alloys by Inductively Coupled Plasma Atomic Emission Spectrometry (Performance Based Method)

G34 Test Method for Exfoliation Corrosion Susceptibility in 2XXX and 7XXX Series Aluminum Alloys (EXCO Test)

G47 Test Method for Determining Susceptibility to Stress-Corrosion Cracking of 2XXX and 7XXX Aluminum Alloy Products

2.3 *ANSI Standards:*<sup>7</sup>

ANSI H35.1/H35.1M Alloy and Temper Designation Systems for Aluminum

ANSI H35.2M Dimensional Tolerances For Aluminum Mill Products (Metric)

2.4 *ISO Standards:*<sup>7</sup>

ISO 209-1 Wrought aluminium and aluminium alloys — Chemical composition and forms of products

ISO 2107 Aluminium, magnesium and their alloys — Temper designations

ISO 6362-2 Wrought aluminium and aluminium alloys — Extruded rods/bars, tubes and profiles — Part 2: Mechanical properties

2.5 *Federal Standard:*<sup>4</sup>

FED-STD-123 Marking for Shipment (Civil Agencies)

2.6 *Military Standard:*<sup>4</sup>

MIL-STD-129 Military Marking for Shipment and Storage

2.7 *AMS Specification:*<sup>5</sup>

AMS 2772 Heat Treatment of Aluminum Alloy Raw Materials

2.8 *CEN Standards:*<sup>6</sup>

CEN EN 14242 Aluminium and aluminium alloys - Chemical analysis - Inductively coupled plasma optical emission spectral analysis

<sup>3</sup>The last approved version of this historical standard is referenced on [www.astm.org](http://www.astm.org).

<sup>7</sup> Available from Aluminum Association, 1400 Crystal Dr., Suite 430, Arlington, VA 22202, <http://www.aluminum.org>.

<sup>4</sup> Available from DLA Document Services, Building 4/D, 700 Robbins Ave., Philadelphia, PA 19111-5094, <http://quicksearch.dla.mil>.

<sup>5</sup> Available from SAE International (SAE), 400 Commonwealth Dr., Warrendale, PA 15096, <http://www.sae.org>.

<sup>6</sup> Available from European Committee for Standardization (CEN), Avenue Marnix 17, B-1000, Brussels, Belgium, <http://www.cen.eu>.

### 3. Terminology

3.1 *Definitions*—Refer to Terminology B881 for definitions of product terms used in this specification.

3.2 *Definitions of Terms Specific to This Standard:*

3.2.1 *capable of*—The term *capable of* as used in this specification means that the test need not be performed by the producer of the material. However, should subsequent testing by the purchaser establish that the material does not meet these requirements, the material shall be subject to rejection.

### 4. Ordering Information

4.1 Orders for material to this specification shall include the following information:

4.1.1 This specification designation (which includes the number, the year, and the revision letter, if applicable),

4.1.2 Quantity in pieces or kilograms,

4.1.3 Alloy (Section 7 and Table 1),

NOTE 4—In the case of a discrepancy in the values listed in Table 2 with those listed in the “International Alloy Designations and Chemical Composition Limits for Wrought Aluminum and Wrought Aluminum Alloys” (known as the “Teal Sheets”),<sup>7</sup> the composition limits registered with the Aluminum Association and published in the “Teal Sheets” should be considered the controlling composition.

4.1.4 Temper (Section 8 and Table 2),

4.1.5 Nominal cross-sectional dimensions as follows:

4.1.5.1 *For Rod and Round Wire*—diameter,

4.1.5.2 *For Square-cornered Bar and Wire*—depth and width,

4.1.5.3 *For Sharp-cornered Hexagonal or Octagonal Bar and Wire*—distance across flats,

4.1.5.4 *For Round Tube*—outside or inside diameter and wall thickness,

4.1.5.5 *For Square or Sharp-cornered Tube Other Than Round*—distance across flats and wall thickness,

4.1.5.6 *For Round-cornered Bar, Profile, Tube Other Than Round, Square, Rectangular, Hexagonal, or Octagonal With Sharp Corners*—drawing required, and

4.1.6 Length.

4.2 Additionally, orders for material to this specification shall include the following information when required by the purchaser:

NOTE 5—For heat-treatable alloys, the default standard to follow for producing T3, T4, T6, T7, T8, and T9 tempers is AMS 2772. However, in the case of most 6XXX and some 7XXX alloys (see 9.2 for list of alloys), the producer may choose to solution heat treat the product at the press in accordance with Practice B807/B807M, as long as the purchaser does not specifically object to this practice in the purchasing agreement. Alternatively, heat treatment may be accomplished in accordance with Practice B918/B918M instead of either of the previous options.

It is up to the purchaser to specify in the purchasing agreement if solution heat treatment at the press is not allowed or if heat treatment in accordance with Practice B918/B918M is preferred, or both. If the purchaser does not specify a preference for a heat treatment practice, Practice B807/B807M may be used for any alloy listed in 9.2, and AMS 2772 shall be the practice used for any other heat-treatable alloy.

4.2.1 Whether solution heat treatment at the press in accordance with Practice B807/B807M is unacceptable (9.2),

4.2.2 Whether heat treatment in accordance with Practice B918/B918M is required (9.3),

4.2.3 Whether ultrasonic inspection is required (Section 17, Table 3),

4.2.4 Whether inspection or witness of inspection and tests by the purchaser's representative is required prior to material shipment (Section 18),

4.2.5 Whether certification is required (Section 22),

4.2.6 Whether marking for identification is required as per Practice B666/B666M (Section 20),

4.2.7 Whether Practices B660 applies and, if so, the levels of preservation, packaging, and packing required (Section 21.3), and

4.2.8 Requirements for tensile property and dimensional tolerance for sizes not specifically covered (8.1.3 and 15.1.1).

4.2.9 Whether Titanium and Zirconium algorithm is allowed as shown in Table 1, footnote H when ordering 2014 or 2024.

4.2.10 Whether Titanium and Zirconium algorithm is allowed as shown in Table 1, footnote T when ordering 7075.

**5. Materials and Manufacture**

5.1 The products covered by this specification shall be produced by the hot extrusion method or by similar methods at the option of the producer, provided that the resulting products comply with the requirements in this specification.

**6. Quality Assurance**

6.1 *Responsibility for Inspection and Tests*—Unless otherwise specified in the contract or purchase order, the producer is responsible for the performance of all inspection and test requirements specified herein. The producer may use their own or any other suitable facilities for the performance of the inspection and test requirements specified herein, unless disapproved by the purchaser in the order or at the time of contract signing. The purchaser shall have the right to perform any of

the inspections and tests set forth in this specification where such inspections are deemed necessary to ensure that material conforms to prescribed requirements.

6.2 *Lot Definition*—An inspection lot shall be defined as follows:

6.2.1 For heat-treated tempers, an inspection lot shall consist of an identifiable quantity of material of the same mill form, alloy, temper, and nominal dimensions traceable to a heat-treat lot or lots, and subjected to inspection at one time.

6.2.2 For nonheat-treated tempers, an inspection lot shall consist of an identifiable quantity of material of the same mill form, alloy, temper, and nominal dimensions subjected to inspection at one time.

**7. Chemical Composition**

7.1 *Limits*—The material shall conform to the chemical composition limits in Table 1. Conformance shall be determined by the producer by taking samples in accordance with E716 when the ingots are poured and analyzing those samples in accordance with E1251, E3061, or EN14242. At least one sample shall be taken for each group of ingots poured simultaneously from the same source of molten metal. If the producer has determined the chemical composition during pouring of the ingots, they shall not be required to sample and analyze the finished product.

NOTE 6—It is standard practice in the United States aluminum industry to determine conformance to the chemical composition limits prior to further processing of ingots into wrought products. Due to the continuous nature of the process, it is not practical to keep a specific ingot analysis identified with a specific quantity of finished material.

7.2 If it becomes necessary to analyze extrusions for conformance to chemical composition limits, the methods of sampling and methods of analysis shall be as provided in the following:

7.2.1 *Methods of Sampling*—Samples for chemical analysis shall be taken in accordance with Practice B985.

7.2.2 *Methods of Analysis*—Analysis shall be performed in accordance with Test Methods E1251, E3061, or EN 14242.

7.3 Other methods of analysis or in the case of dispute may be by agreement between the producer and the purchaser.

NOTE 7—It is difficult to obtain a reliable analysis of each of the components of clad materials using material in its finished state. A reasonably accurate determination of the core composition can be made if the cladding is substantially removed prior to analysis. The cladding composition is more difficult to determine because of the relatively thin layer and because of diffusion of core elements to the cladding. The correctness of cladding alloy used can usually be verified by a combination of metallographic examination and spectrochemical analysis of the surface at several widely separated points.

7.4 *Methods of Analysis*—The determination of chemical composition shall be made in accordance with suitable chemical (Test Methods E34) or spectrochemical (Test Method E1251, E3061, or EN14242) methods. Other methods may be used only when no published ASTM test method is available. In case of dispute, the methods of analysis shall be agreed upon between the producer and purchaser.

**8. Tensile Properties of Material From Producer**

8.1 *Limits*—The material shall conform to the tensile property requirements specified in Table 2.

**TABLE 3 Ultrasonic Discontinuity Limits for Extruded Bar and Profiles<sup>A</sup>**

Alloy	Thickness, <sup>B</sup> mm		Mass max per Piece, kg	Max Width, Thickness Ratio	Discontinuity Class <sup>C</sup>
	over	incl			
2014 2024 2219	12.50		300	10:1	B
7075 7178	12.50 35.00	35.00 ...	300 300	10:1 10:1	B A

<sup>A</sup> Discontinuities in excess of those listed in this table shall be allowed, subject to the approval of the procuring activity, if it is established that they will be removed by machining or that they are in noncritical areas.

<sup>B</sup> The thickness of any element of a "profile" shall be deemed to be the smallest dimension of that element and the discontinuity class applicable to that particular thickness shall apply to that element of the profile.

<sup>C</sup> The discontinuity class limits are defined in Section 11 of Practice B594.

8.1.1 The elongation requirements shall not be applicable to the following:

8.1.1.1 Material of such dimensions that a standard test specimen cannot be taken in accordance with Test Methods B557M, and of such profile that it cannot be satisfactorily tested in full section.

8.1.1.2 Material up through 1.60 mm in thickness.

8.1.1.3 Wire up through 3.20 mm in diameter.

8.1.2 The measurement for yield strength is not required for wire up through 3.20 mm in diameter.

8.1.3 Tensile property limits for sizes not covered in Table 2 shall be as agreed upon between the producer and purchaser and shall be so specified in the contract or purchase order.

8.2 *Number of Specimens:*

8.2.1 For material having a nominal mass up through 1.7 kg/linear m, one tension test specimen shall be taken for each 500 kg or fraction thereof in the lot.

8.2.2 For material having a nominal mass over 1.7 kg/linear m, one tension test specimen shall be taken for each 300 m or fraction thereof in the lot.

8.2.3 Other procedures for selecting samples may be employed if agreed upon between the producer or supplier and the purchaser.

8.3 Geometry of test specimens and the location in the product from which they are taken shall be as specified in Test Methods B557M.

8.4 *Test Methods*—The tension tests shall be made in accordance with Test Methods B557M.

8.5 *Retests*—When there is evidence that the test specimen is defective or is not representative of the lot of material, retesting may be performed in accordance with Section 8 and 9 of Test Methods B557M.

## 9. Heat Treatment

9.1 Producer or supplier heat treatment for the production of T1, T2, T5 and T10-type tempers shall be in accordance with Practice B945. Producer or supplier heat treatment for the production of T3, T4, T6, T7, T8, and T9-type tempers, unless otherwise specified in 9.2 or unless otherwise specified in 9.3, shall be in accordance with AMS 2772.

9.2 Unless otherwise specified (4.2.1), alloys 6005A, 6013, 6041, 6060, 6061, 6063, 6064, 6066, 6070, 6082, 6105, 6162, 6262, 6351, 6360, 6463, 6560, and 7129 may be solution heat treated and quenched at the extrusion press in accordance with Practice B807/B807M for the production of T3, T4 T6, T7, T8, and T9-type tempers.

9.3 When specified (4.2.2), heat treatment of the production of T3, T4, T6, T7, T8, and T9-type tempers shall be in accordance with Practice B918/B918M.

## 10. Producer Confirmation of Heat-Treat Response

10.1 In addition to the requirements of Section 8, material in alloys 2014, 2024, and 6061 produced in the O or F temper (within the size limits specified in Table 2) shall, after proper solution heat treatment and natural aging for not less than four days at room temperature, conform to the properties specified

in Table 2 for T42 temper material. The heat-treated samples may be tested prior to four days natural aging but if they fail to conform to the T42 temper properties, the test may be repeated after completion of four days natural aging without prejudice.

10.2 Alloys 2219, 7075, and 7178 material produced in the O or F temper (within the size limits specified in Table 2) shall, after proper solution heat treatment and precipitation heat treatment, conform to the properties specified in Table 2 for T62 temper material.

10.3 *Number of Specimens*—The number of specimens from each lot of O temper material and F temper material to be tested to verify conformance with 10.1 and 10.2 shall be as specified in 8.2.

## 11. Heat Treatment and Reheat-Treatment Capability

11.1 As-received material in the O or F temper in alloys 2014, 2024, and 6061 (within the size limitations specified in Table 2 and without the imposition of cold work) shall be capable of conforming to the properties specified in Table 2 for T42 temper upon being properly solution heat-treated and naturally aged for not less than four days at room temperature.

11.2 As-received material in the O and F tempers in alloys 2219, 7075, and 7178 (within the size limitations specified in Table 2 and without the imposition of cold work) shall be capable of conforming to the properties specified in Table 2 for the T62 temper upon being properly solution and precipitation heat-treated.

11.3 Material in alloys and tempers 2014-T4, T4510, T4511, T6, T6510, and T6511, and 2024-T3, T3510, T3511, T81, T8510, and T8511 shall be capable of conforming to the properties specified in Table 2 for the T42 temper upon being properly resolution heat-treated and naturally aged for not less than four days at room temperature.

NOTE 8—6061-T4, T6, T4510, T4511, T6510, and T6511 are deleted from 11.3 because experience has shown the reheat-treated material tends to develop large recrystallized grains and may fail to develop the tensile properties shown in Table 2.

11.4 Alloy 2219 in the T31, T3510, T3511, T81, T8510, and T8511 tempers, and alloys 7075 and 7178 in the T6, T651, T6510, and T6511 tempers shall be capable of conforming to the properties specified in Table 2 for the T62 temper upon being properly resolution heat-treated and precipitation heat-treated.

11.5 Material in T3/T31, T3510, T3511, T4, T4510, and T4511 tempers shall be capable of conforming upon being properly precipitation heat-treated, to the properties specified in Table 2 for the T81, T8510, T8511, T6, T6510, and T6511 tempers, respectively.

## 12. Stress-Corrosion Resistance

12.1 Alloy 7075 in the T73 and T76-type tempers and alloy 7178 in the T76-type tempers shall be capable of exhibiting no evidence of stress-corrosion cracking when subjected to the test specified in 12.2.

12.1.1 For lot-acceptance purposes, resistance to stress-corrosion cracking for each lot of material shall be established

by testing the previously selected tension-test samples to the criteria shown in Table 4.

12.1.2 For surveillance purposes, each month the producer shall perform at least one test for stress corrosion resistance in accordance with 12.2 on each applicable alloy temper for each thickness range 20.00 and over produced that month. Each sample shall be taken from material considered acceptable in accordance with the lot-acceptance criteria of Table 4. A minimum of three adjacent replicate specimens shall be taken from each sample and tested. The producer shall maintain records of all lots so tested and make them available for examination at the producer’s facility.

12.2 The stress-corrosion cracking test shall be performed on material 20.00 mm and over in thickness as follows:

12.2.1 Specimens shall be stressed in tension in the short transverse direction with respect to grain flow and held at constant strain. The stress level shall be 75 % of the specified minimum yield strength for T73-type tempers and 170 MPa for T76-type tempers.

12.2.2 The stress-corrosion test shall be made in accordance with Test Method G47.

12.2.3 There shall be no visual evidence of stress-corrosion cracking in any specimen, except that the retest provisions of 19.2 shall apply.

**13. Exfoliation-Corrosion Resistance**

13.1 Alloys 7075 and 7178 in the T76, T76510, and T76511 tempers shall be capable of exhibiting no evidence of exfoliation corrosion equivalent to or in excess of that illustrated by

Category B in Fig. 2 of ASTM G34 Test Method for Exfoliation Corrosion Susceptibility in 2XXX and 7XXX Series Aluminum Alloys (EXCO Test) when tested in accordance with 13.1.1.

13.1.1 For surveillance purposes, each month at least one exfoliation-corrosion test shall be performed for each size range of extrusions produced during that month. The test shall be in accordance with ASTM G34 Test Method for Exfoliation Corrosion Susceptibility in 2XXX and 7XXX Series Aluminum Alloys (EXCO Test) on material considered acceptable in accordance with lot-acceptance criteria of Table 4. Specimens shall be selected at random and shall be, if possible, a minimum of 50 by 100 mm with the 100 mm dimension in a plane parallel to the direction of extrusion. The test location shall be in accordance with that specified in Table 4. The producer shall maintain records of all surveillance test results and make them available for examination at the producer’s facility.

13.2 For lot-acceptance purposes, resistance to exfoliation corrosion for each lot of material in the alloys and tempers listed in 13.1 shall be established by testing the previously selected tension-test samples to the criteria shown in Table 4.

**14. Cladding**

14.1 The aluminum-alloy cladding on clad tube shall comprise the inside surface (only) of the tube and its thickness shall be approximately 10 % of the total wall thickness.

14.2 When the cladding thickness is to be determined on finished tube, transverse cross sections of at least three tubes

**TABLE 4 Lot Acceptance Criteria for Resistance to Stress Corrosion and Exfoliation Corrosion**

Alloy and Temper	Lot Acceptance Criteria		Lot Acceptance Status
	Electrical Conductivity, <sup>A</sup> % IACS	Level of Mechanical Properties	
7075-T73 T73510 and T73511	40.0 or greater	per specified requirements	acceptable
	38.0 through 39.9	per specified requirements and yield strength does not exceed minimum by more than 82 MPa	acceptable
	38.0 through 39.9	per specified requirements but yield strength exceeds minimum by more than 82 MPa	unacceptable <sup>B</sup>
7075-T76, T76510, and T76511	less than 38.0	any level	unacceptable <sup>B</sup>
	38.0 or greater	per specified requirements	acceptable
	36.0 through 37.9	per specified requirements	suspect <sup>C</sup>
7178-T76, T76510, and T76511	less than 36.0	any level	unacceptable <sup>B</sup>
	38.0 or greater	per specified requirements	acceptable
	35.0 through 37.9	per specified requirements	suspect <sup>C</sup>
	less than 35.0	any level	unacceptable <sup>B</sup>

<sup>A</sup> Sampling for electrical conductivity tests shall be the same as for tensile tests as specified in 8.2. Test specimens may be prepared by machining a flat, smooth surface of sufficient width for proper testing. For small sizes of tubes, a cut-out portion may be flattened and the conductivity determined on the surface. Chemical milling may be used on flat surface samples. The electrical conductivity shall be determined in accordance with Practice E1004 in the following locations:

<sup>B</sup> When material is found to be unacceptable, it shall be reprocessed (additional precipitation heat treatment or re-solution heat treatment, stress relieving, straightening, and precipitation heat treatment, when applicable).

<sup>C</sup> When material in these tempers is found to be suspect it is either tested for exfoliation corrosion resistance in accordance with Test Method G34 and stress corrosion in accordance with Test Method G47, or it is reprocessed (additional precipitation heat treatment or resolution heat treatment and precipitation heat treatment). Favorable exfoliation corrosion test results must never be used as acceptance criteria for stress corrosion resistance.

Section Thickness, mm		Location
over	through	
...	2.50	surface of tension sample
2.50	12.50	subsurface after removal of approximately 10 % of the thickness
12.50	40.00	subsurface at approximate center of section thickness, on a plane parallel to the longitudinal center line of the material.
40.00	...	subsurface on tension-test specimen surface that is closest to the center of the section thickness and on a plane parallel to the extrusion surface.

from the lot shall be polished for examination with a metallurgical microscope. Using a 100× magnification, the cladding thickness at four points 90° apart in each sample shall be measured and the average of the twelve measurements shall be taken as the thickness. For a tube having a diameter larger than can be properly mounted for polishing and examination, the portions of the cross section polished for examination may consist of an arc about 12 mm in length.

## 15. Dimensional Tolerances

15.1 *Dimensions*—Variations from the specified dimensions for the type of material ordered shall not exceed the permissible variations prescribed in the tables of ANSI H35.2M (see Table 5).

15.1.1 Dimensional tolerances for sizes not covered in ANSI H35.2M shall be as agreed upon between the producer and purchaser and shall be so specified in the contract or purchase order.

15.2 *Sampling for Inspection*—Examination for dimensional conformance shall be made to ensure conformance to the tolerance specified.

## 16. General Quality

16.1 Unless otherwise specified, the extruded bar, rod, wire, profile, and tube shall be supplied in the mill finish and shall be uniform as defined by the requirements of this specification and

shall be commercially sound. Any requirement not so covered is subject to negotiation between the producer and purchaser.

16.2 Each bar, rod, wire, profile, or tube shall be examined to determine conformance to this specification with respect to general quality and identification marking. On approval of the purchaser, however, the producer or the supplier may use a system of statistical quality control for such examination.

## 17. Internal Quality

17.1 When specified by the purchaser at the time of placing the contract or order, each bar or profile over 12.50 mm in thickness or smallest dimension, in alloys 2014, 2024, 2219, 7075, and 7178 shall be tested ultrasonically in accordance with Practice B594 to the discontinuity acceptance limits of Table 3.

## 18. Source Inspection

18.1 If the purchaser desires that his representative inspect or witness the inspection and testing of the material prior to shipment, such agreement shall be made by the purchaser and the producer or supplier as part of the purchase contract.

18.2 When such inspection or witness of inspection and testing is agreed upon, the producer or supplier shall afford the purchaser's representative all reasonable facilities to satisfy him that the material meets the requirements of this specification. Inspection and tests shall be conducted so there is no unnecessary interference with the producer's or supplier's operations.

## 19. Retest and Rejection

19.1 If any material fails to conform to all of the applicable requirements of this specification, it shall be cause for rejection of the inspection lot.

19.2 When there is evidence that a failed specimen was not representative of the inspection lot and when no other sampling plan is provided or approved by the purchaser through the contract or purchase order, at least two additional specimens shall be selected to replace each test specimen that failed. All specimens so selected for retest shall meet the requirements of the specification or the lot shall be subject to rejection.

19.3 Material in which defects are discovered subsequent to inspection may be rejected.

19.4 If material is rejected by the purchaser, the seller is responsible only for replacement of the material to the purchaser. As much as possible of the rejected material shall be returned to the seller by the purchaser.

## 20. Identification Marking of Product

20.1 When specified in the contract or purchase order, all material shall be marked in accordance with Practice B666/B666M.

NOTE 9—Ordering per Practice B666/B666M will require the supplier to mark the lot number on each extruded section.

20.2 The requirements specified in 20.1 are the minimum; marking systems that involve added information, larger

TABLE 5 Tables of ANSI H35.2M

Table No.	Title
11.2	Cross-Sectional Dimension Tolerances: Profiles Except for Profiles in T3510, T4510, T6510, T73510, T76510 and T8510 Tempers
11.3	Diameter or Distance across Flats—Round Wire and Rod—Square, Hexagonal and Octagonal Wire and Bar
11.4	Thickness or Width (Distance Across Flats)—Rectangular Wire and Bar
11.5	Length: Wire, Rod, Bar and Profiles
11.6	Straightness: Rod, Bar and Profiles
11.7	Twist—Bar and Profiles
11.8	Flatness (Flat Surfaces)—Bar, Solid Profiles and Semi-hollow Profiles Except for O, T3510, T4510, T6510, T73510, T76510, and T8510 Tempers
11.9	Flatness (Flat Surfaces)—Hollow Profiles Except for O, T3510, T4510, T6510, T73510, T76510 and T8510 Tempers
11.10	Surface Roughness—Wire, Rod, Bar and Profiles
11.11	Contour (Curved Surfaces) Profiles
11.12	Squareness of Cut Ends—Wire, Rod, Bar and Profiles
11.13	Corner and Fillet Radii—Bar and Profiles
11.14	Angularity—Bar and Profiles Except for O, T3510, T4510, T6510, T73510, T76510, and T8510 Tempers
12.2	Diameter—Round Tube Except for T3510, T4510, T6510, T73510, T76510, and T8510 Tempers
12.3	Width and Depth—Square, Rectangular, Hexagonal, Octagonal Tube Except for T3510, T4510, T6510, T73510, T76510, and T8510 Temper
12.4	Wall Thickness—Round Extruded Tube
12.5	Wall Thickness—Other Than Round Extruded Tube
12.6	Length—Extruded Tube
12.7	Twist—Other Than Round Extruded Tube
12.8	Straightness—Tube in Straight Lengths
12.9	Flatness (Flat Surfaces)
12.10	Squareness of Cut Ends
12.11	Corner and Fillet Radii—Tube Other Than Round
12.12	Angularity—Tube Other Than Round
12.13	Surface Roughness—Extruded Tube
12.14	Dents—Extruded Tube

characters, and greater frequencies are acceptable under this specification, and shall be agreed upon by the producer and purchaser.

## 21. Packaging and Package Marking

21.1 The material shall be packaged to provide adequate protection during normal handling and transportation and each package shall contain only one size, alloy, and temper of material unless otherwise agreed upon. The type of packing and gross mass of containers shall, unless otherwise agreed upon, be at the producer or supplier's discretion, provided they are such as to ensure acceptance by common or other carriers for safe transportation at the lowest rate to the delivery point.

21.2 Each shipping container shall be marked with the purchase order number, material size, specification number, alloy and temper, gross and net masses, and the producer's name or trademark.

21.3 When specified in the contract or purchase order, material shall be preserved, packaged, and packed in accordance with the requirements of Practices B660. The applicable level shall be as specified in the contract or order. Marking for shipment of such material shall be in accordance with Fed. Std. No. 123 for civil agencies and MIL-STD-129 for Military agencies.

## 22. Certification

22.1 The producer or supplier shall, on request, furnish to the purchaser a certificate stating that each lot has been sampled, tested, and inspected in accordance with this specification and has met the requirements.

## 23. Keywords

23.1 aluminum alloy; extruded bars; extruded profiles; extruded rods; extruded tubes; extruded wire

## ANNEXES

### (Mandatory Information)

#### A1. BASIS FOR INCLUSION OF PROPERTY LIMITS

A1.1 Limits are established at a level at which a statistical evaluation of the data indicates that 99 % of the population obtained from all standard material meets the limit with 95 % confidence. For the products described, mechanical property limits for the respective size ranges are based on the analyses of at least 100 data from standard production material with no more than ten data from a given lot. All tests are performed in accordance with the appropriate ASTM test methods. For informational purposes, refer to "Statistical Aspects of Mechanical Property Assurance" in the Related Material section of the Annual Book of ASTM Standards, Vol 02.02.

A1.2 Mechanical property limits are established in accord with section 6, Standards Section, of the most current edition of the Aluminum Standards and Data and the latest edition of the Aluminum Association publication "Tempers for Aluminum and Aluminum Alloy Products (Yellow and Tan Sheets)."

A1.3 Limits are based on a statistical evaluation of the data indicating that at least 99 % of the population obtained from all standard material meets the limit with 95 % confidence. For the products described, mechanical property limits are based on the statistical analyses of at least 100 tests from at least five

cast lots of standard production material with no more than ten observations from a given heat treat or inspection lot. Mechanical properties limits for press solution heat treated products have specific additional requirements which are provided in the "Tempers for Aluminum and Aluminum Alloy Products."

A1.4 Limits denoted as "Tentative" by the Aluminum Association may be included. Requirements for tentative property registrations are defined in the latest edition of the Aluminum Association publication "Tempers for Aluminum and Aluminum Alloy Products." Tentative property limits are established at levels at which at least 99 % of the data conform at a confidence level of 95 %. Tentative property limits, which are subject to revision, shall be based on a statistical analysis of at least 30 tests from at least 3 cast lots of standard production material with no more than 10 observations from a given heat treat or inspection lot. Where tentative property limits are listed, they shall be shown in italics and footnoted as Tentative in the standard.

A1.5 All tests are performed in accordance with the appropriate ASTM test methods.

## A2. ACCEPTANCE CRITERIA FOR INCLUSION OF NEW ALUMINUM AND ALUMINUM ALLOYS IN THIS SPECIFICATION

A2.1 Prior to acceptance for inclusion in this specification, the composition of wrought or cast aluminum or aluminum alloy shall be registered in accordance with ANSI H35.1/H35.1M. The Aluminum Association holds the Secretariat of ANSI H35 Committee and administers the criteria and procedures for registration.

A2.2 If it is documented that the Aluminum Association could not or would not register a given composition, an alternative procedure and the criteria for acceptance shall be as follows:

A2.2.1 The designation submitted for inclusion does not utilize the same designation system as described in ANSI H35.1/H35.1M. A designation not in conflict with other designation systems or a trade name is acceptable.

A2.2.2 The aluminum or aluminum alloy has been offered for sale in commercial quantities within the prior twelve months to at least three identifiable users.

A2.2.3 The complete chemical composition limits are submitted.

A2.2.4 The composition is, in the judgment of the responsible subcommittee, significantly different from that of any other aluminum or aluminum alloy already in the specification.

A2.2.5 For codification purposes, an alloying element is any element intentionally added for any purpose other than grain refinement and for which minimum and maximum limits are specified. Unalloyed aluminum contains a minimum of 99.00 % aluminum.

A2.2.6 Standard limits for alloying elements and impurities are expressed to the following decimal places:

Less than 0.001 %	0.000X
0.001 to but less than 0.01 %	0.00X
0.01 to but less than 0.10 %	
Unalloyed aluminum made by a refining process	0.0XX
Alloys and unalloyed aluminum not made by a refining process	0.0X
0.10 through 0.55 %	0.XX
(It is customary to express limits of 0.30 through 0.55 % as 0.X0 or 0.X5.)	
Over 0.55 %	0.X, X.X,
(except that combined Si + Fe limits for 99.00 % minimum aluminum must be expressed as 0.XX or 1.XX)	and so forth

A2.2.7 Standard limits for alloying elements and impurities are expressed in the following sequence: Silicon; Iron; Copper; Manganese; Magnesium; Chromium; Nickel; Zinc; Titanium (Note A2.1); Other Elements, Each; Other Elements, Total; Aluminum (Note A2.2).

NOTE A2.1—Additional specified elements having limits are inserted in alphabetical order of their chemical symbols between titanium and Other Elements, Each, or are specified in footnotes.

NOTE A2.2—Aluminum is specified as *minimum* for unalloyed aluminum and as a *remainder* for aluminum alloys.

## APPENDIXES

### (Nonmandatory Information)

## X1. ISO EQUIVALENTS OF ANSI ALLOYS AND TEMPERS

X1.1 International Organization for Standardization (ISO) equivalents of the ANSI alloys and tempers given in Table X1.1 and Table X1.2 are included in ISO 209-1: 1989, Part 1, Chemical Composition and ISO 2107-1983. Mechanical property limits shown in Part 2, Mechanical Properties, of ISO 6362-2: 1990 are similar to B221M but not necessarily identical.

TABLE X1.1 ISO Equivalents of Alloys in B221M

Alloys			
ANSI	ISO	ANSI	ISO
1060	Al 99.6	6005	Al SiMg
1100	Al 99.0 Cu	6005A	Al SiMg (A)
2014	Al Cu4SiMg	6060	Al MgSi
2024	Al Cu4Mg1	6061	Al Mg1SiCu
2219	Al Cu6Mn	6263	Al Mg0.7Si
3003	Al Mn1Cu	6262	Al Mg1SiPb
3004	Al Mn1Mg1	6351	Al Si1Mg0.5Mn
5052	Al Mg2.5	7005	Al Zn4.5Mg1.5Mn
5083	Al Mg4.5Mn0.7	7075	Al Zn5.5MgCu
5086	Al Mg4	7178	Al Zn7MgCu
5154	Al Mg3.5		
5454	Al Mg3Mn		
5456	Al Mg5Mn1		

TABLE X1.2 ISO Equivalents of Tempers in B221M

Tempers	
ANSI	ISO
F	F
O	O
H112	M
T1	TA
T3	TD
T4	TB
T5	TE
T6	TF
T7	TM
T8	TH

X2. DESIGNATIONS FOR METALS AND ALLOYS FORMERLY ASSIGNED IN CONFORMANCE WITH PRACTICE B275

X2.1 Designations assigned in conformance with this practice were used for wrought aluminum and wrought aluminum alloys in ASTM specifications prior to 1960 and for cast aluminum and aluminum alloys and ingot prior to 1974, but now designations conforming to the American National Standard Alloys and Temper Designation Systems for Aluminum (ANSI H35.1/H35.1M) are standard with the UNS, Practice E527 for information only. The former ASTM designations and the corresponding ANSI and UNS designations for wrought alloys are as shown in Table X3.1. Cast alloys and ingot are as shown in Table X3.2.

TABLE X2.1 Wrought Aluminum Alloys

Designations					
ANSI H35.1/H35.1M	Former B275 - 63	UNS	ANSI H35.1/H35.1M	Former B275 - 63	UNS
1060	996A	A91060	5056	GM50A	A95056
1100	990A	A91100	5083	GM41A	A95083
2011	CB60A	A92011	5086	GM40A	A95086
2014	CS41A	A92014	5154	GR40A	A95154
2017	CM41A	A92017	5254	GR40B	A95254
2018	CN42C	A92018	5454	GM31A	A95454
2024	CG42A	A92024	5456	GM51A	A95456
2117	CG30A	A92117	5652	GR20B	A95652
3003	M1A	A93003	6053	GS11B	A96053
3004	MG11A	A93004	6061	GS11A	A96061
4032	SG121A	A94032	6063	GS10A	A96063
5005	G1B	A95005	6101	GS10B	A96101
5050	G1A	A95050	7075	ZG62A	A97075
5052	GR20A	A95052			

SUMMARY OF CHANGES

Committee B07 has identified the location of selected changes to this standard since the last issue (B221M – 13) that may impact the use of this standard. (Approved Sept. 1, 2021.)

- (1) Added B985 and E3061 to Referenced Documents, and removed E34 and E607 (withdrawn in 2011).
- (2) Removed footnote 3 and renumbered subsequent footnotes. (The last approved version of this historical standard is referenced on [www.astm.org](http://www.astm.org)).
- (3) Changed ANSI reference to Aluminum Association and address in corresponding footnote. Consolidated footnote references to Aluminum Association throughout.

- (4) Changed Specification B234 to B234M in Referenced Documents, as the metric version of the standard is appropriate version to be referenced by a metric standard.
- (5) Updated references to Practice B918 to B918/B918M throughout.
- (6) Updated Annex A1 IAW standardized language.

- (7) Re-labelled “Note 1” of Table 1 as Note 4, in order to be in sequence with other notes, and updated verbiage in accordance with standardized language.
- (8) Added new Note 5 to provide clarity about choices for heat treatment methods for the purchaser. Renumbered subsequent notes accordingly.
- (9) Revised 4.2.1 by using the phrase “solution heat treatment in accordance with Practice B807/B807M” to match standardized language.
- (10) In Table 1, corrected 4.2.9 and 4.2.10 references to footnote H and T, respectively..
- (11) Removed Test Methods E34 and E607 as approved testing methods from, and added Test Method E3061 to, 7.1 and 7.2.
- (12) Revised 7.2.1 in accordance with standardized language, with the use of B985 as the standard method for sampling.
- (13) Revised 7.2.2 in accordance with standardized language
- (14) Revised Section 9 by consolidating 9.1 and 9.2 into new 9.1, in accordance with standardized language, renumbering remaining paragraphs in Section 9 and adjusting related items in Section 4.
- (15) Revised Section 9 to show all applicable tempers for each heat treatment option.
- (16) Revised 9.2 to reflect all B221 6XXX and 7XXX alloys in common with B807/B807M.
- (17) Made corrections to chemistry of 6060 in Table 1, IAW AA Registration Series (Teal Sheets).
- (18) Added alloy 6026 to Table 1, which required inserting new footnote L, and renamed previous footnotes L through U in order to keep alphabetical order.
- (19) Moved footnotes G, H, I, J, Q, R, S, T, and U in Table 1 to alloy number to be consistent through standard.
- (20) Abbreviated “remainder” with “rem” in Aluminum column in Table 1 IAW standardized language.
- (21) Added column for Product Type in Table 2, and identified which products are covered by listed tempers for each alloy.
- (22) Removed F temper lines from applicable alloys and revised footnote E to “These alloys are also produced in the F temper for which no tensile properties are specified or guaranteed.” to reflect the approach to F tempers in Table 2 in B221.
- (23) Added Extruded Tube properties for 2024 to Table 2. Removed footnotes G, H, and I from Table 2, as they are unnecessary due to adding column for Product Type.
- (24) Added T3511 to alloy 2219.
- (25) Added separate properties for 3003 H112 for Extruded Wire, Rod, Bar and Profiles and 3003 H112 Extruded Tube, IAW Aluminum Standards and Data.
- (26) Eliminated footnote J from Alclad 3003 H112, IAW Aluminum Standards and Data as it is no longer necessary due to adding Product Type column and does not correspond to AS&D or other ASTM standards.
- (27) Corrected thickness range for 3102 H112 to correspond to AA Tan Sheets.
- (28) Removed footnote K reference for 3102 from Table 2 as it is not needed due to adding Product Type column.
- (29) Removed footnote L reference for 5083, 5086, 5454, 5456 and 7075 tube wall maximum and added Extruded Tube entries for each alloy.
- (30) Removed “Tentative” footnote from 6041 in Table 2, and deleted footnote M as it does not apply to any current entries.
- (31) Added footnote C to Table 2 in order to clarify the source of the Product Type information, and re-labelled subsequent footnotes.
- (32) Applied footnote E to Alloy 5052 to correspond to ASTM B241/B241M.
- (33) Created new footnote H in Table 2 to point out that Specified Wall Thickness for 5083, 5086 and 5454 Extruded Tube is not IAW Aluminum Standards and Data, which specifies wall thickness as “all.”
- (34) Created new footnote I in Table 2 to point out that Specified Wall Thickness for 5456 Extruded Tube is not IAW Aluminum Association Tan Sheets, which specifies wall thickness as “120.00 mm.”
- (35) Added alloy 6026 and associated tempers to Table 2.
- (36) Corrected 6042-T551 to T5511 in Table 2 IAW AA Tan Sheets.
- (37) Added 6082-T6 Extruded Tube properties to Table 2 IAW Aluminum Standards and Data.
- (38) Added footnote F to all stress-relieved tempers (T3510, T3511, T4510, T4511, T5510, T5511, T6510, T6511, T73510, T73511, T76510, T76511, T8510, T8511).
- (39) Added T6 temper and corrected T1 and T5 tempers to 6105 entries in Table 2 IAW AS&D and Tan Sheets.
- (40) Added T62 temper to 6262 IAW AS&D
- (41) Added Tubing properties for Alloy 7075 separate from Extruded Wire, Rod, Bar and Profiles.
- (42) Removed Alloy 7178 from this standard due to being inactivated by the Aluminum Association.

ASTM International takes no position respecting the validity of any patent rights asserted in connection with any item mentioned in this standard. Users of this standard are expressly advised that determination of the validity of any such patent rights, and the risk of infringement of such rights, are entirely their own responsibility.

This standard is subject to revision at any time by the responsible technical committee and must be reviewed every five years and if not revised, either reapproved or withdrawn. Your comments are invited either for revision of this standard or for additional standards and should be addressed to ASTM International Headquarters. Your comments will receive careful consideration at a meeting of the responsible technical committee, which you may attend. If you feel that your comments have not received a fair hearing you should make your views known to the ASTM Committee on Standards, at the address shown below.

This standard is copyrighted by ASTM International, 100 Barr Harbor Drive, PO Box C700, West Conshohocken, PA 19428-2959, United States. Individual reprints (single or multiple copies) of this standard may be obtained by contacting ASTM at the above address or at 610-832-9585 (phone), 610-832-9555 (fax), or service@astm.org (e-mail); or through the ASTM website (www.astm.org). Permission rights to photocopy the standard may also be secured from the Copyright Clearance Center, 222 Rosewood Drive, Danvers, MA 01923, Tel: (978) 646-2600; http://www.copyright.com/

ASMENORMDOC.COM : Click to view the full PDF of ASME BPVC.II.B (ASME BPVC Section II part B) 2025

INTENTIONALLY LEFT BLANK

# SPECIFICATION FOR ALUMINUM AND ALUMINUM-ALLOY DRAWN SEAMLESS TUBES FOR CONDENSERS AND HEAT EXCHANGERS



**SB-234**

(Identical with ASTM Specification B234-10 except that certification and test reports have been made mandatory.)

ASMENORMDOC.COM : Click to view the full PDF of ASME BPVC.II.B (ASME BPVC Section II part B) 2025

# Standard Specification for Aluminum and Aluminum-Alloy Drawn Seamless Tubes for Condensers and Heat Exchangers

## 1. Scope

1.1 This specification covers aluminum-alloy (Note 1) drawn seamless round tube in straight lengths designated as shown in Table 2, for use in surface condensers, evaporators, and heat exchangers.

NOTE 1—Throughout this specification use of the term *alloy* in the general sense includes aluminum as well as aluminum alloy.

NOTE 2—For drawn seamless tubes used in general applications, see Specifications B210 and B210M; for extruded tubes see Specifications B221 and B221M; for seamless pipe and seamless extruded tube used in pressure applications see Specification B241/B241M; and for structural pipe and tube see Specification B429/B429M.

1.2 Alloy and temper designations are in accordance with ANSI H35.1/H35.1(M). The equivalent Unified Numbering System alloy designations are those of Table 1 preceded by A9, for example, A91060 for aluminum 1060, in accordance with Practice E527.

1.3 For acceptance criteria for inclusion of new aluminum and aluminum alloys in this specification, see Annex A2.

1.4 This specification is the inch-pound companion to Specification B234M; therefore, no SI equivalents are presented in the specification.

1.5 *This standard does not purport to address all of the safety concerns, if any, associated with its use. It is the responsibility of the user of this standard to establish appropriate safety and health practices and determine the applicability of regulatory limitations prior to use.*

## 2. Referenced Documents

2.1 The following documents of the issue in effect on date of material purchase form a part of this specification to the extent referenced herein:

### 2.2 ASTM Standards:

- B210 Specification for Aluminum and Aluminum-Alloy Drawn Seamless Tubes
- B210M Specification for Aluminum and Aluminum-Alloy Drawn Seamless Tubes (Metric)
- B221 Specification for Aluminum and Aluminum-Alloy Extruded Bars, Rods, Wire, Profiles, and Tubes
- B221M Specification for Aluminum and Aluminum-Alloy Extruded Bars, Rods, Wire, Profiles, and Tubes (Metric)
- B241/B241M Specification for Aluminum and Aluminum-Alloy Seamless Pipe and Seamless Extruded Tube
- B429/B429M Specification for Aluminum-Alloy Extruded Structural Pipe and Tube
- B557 Test Methods for Tension Testing Wrought and Cast Aluminum- and Magnesium-Alloy Products
- B660 Practices for Packaging/Packing of Aluminum and Magnesium Products
- B666/B666M Practice for Identification Marking of Aluminum and Magnesium Products
- B881 Terminology Relating to Aluminum- and Magnesium-Alloy Products
- B918 Practice for Heat Treatment of Wrought Aluminum Alloys
- E29 Practice for Using Significant Digits in Test Data to Determine Conformance with Specifications
- E34 Test Methods for Chemical Analysis of Aluminum and Aluminum-Base Alloys
- E215 Practice for Standardizing Equipment for Electromagnetic Testing of Seamless Aluminum-Alloy Tube
- E527 Practice for Numbering Metals and Alloys in the Unified Numbering System (UNS)
- E607 Test Method for Atomic Emission Spectrometric Analysis Aluminum Alloys by the Point to Plane Technique Nitrogen Atmosphere (Withdrawn 2011)
- E716 Practices for Sampling and Sample Preparation of Aluminum and Aluminum Alloys for Determination of

TABLE 1 Chemical Composition Limits<sup>A,B,C</sup>

Alloy	Silicon	Iron	Copper	Manganese	Magnesium	Chromium	Zinc	Titanium	Other Elements <sup>D</sup>		Aluminum
									Each	Total <sup>E</sup>	
1060	0.25	0.35	0.05	0.03	0.03	...	0.05	0.03	0.03 <sup>F</sup>	...	99.60 min <sup>G</sup>
3003	0.6	0.7	0.05–0.20	1.0–1.5	...	...	0.10	...	0.05	0.15	remainder
Alclad 3003					3003 alloy clad with 7072 alloy						
5052	0.25	0.40	0.10	0.10	2.2–2.8	0.15–0.35	0.10	...	0.05	0.15	remainder
5454	0.25	0.40	0.10	0.50–1.0	2.4–3.0	0.05–0.20	0.25	0.20	0.05	0.15	remainder
6061	0.40–0.8	0.7	0.15–0.40	0.15	0.8–1.2	0.04–0.35	0.25	0.15	0.05	0.15	remainder
7072 <sup>H</sup>	0.7 Si + Fe		0.10	0.10	0.10	...	0.8–1.3	...	0.05	0.15	remainder

<sup>A</sup> Limits are in percent maximum unless shown as a range or otherwise stated.

<sup>B</sup> Analysis shall be made for the elements for which limits are shown in this table.

<sup>C</sup> For purposes of determining conformance to these limits, an observed value or a calculated value attained from analysis shall be rounded to the nearest unit in the last right-hand place of figures used in expressing the specified limit, in accordance with the rounding-off method of Practice E29.

<sup>D</sup> *Others* includes listed elements for which no specific limit is shown as well as unlisted metallic elements. The producer may analyze samples for trace elements not specified in this specification. However, such analysis is not required and may not cover all metallic *Others* elements. Should any analysis by the producer or the purchaser establish that an *Others* element exceeds the limit of *Each* or that the aggregate of several *Others* elements exceeds the limit of *Total*, the material shall be considered nonconforming.

<sup>E</sup> *Other Elements—Total* shall be the sum of unspecified metallic elements 0.010 % or more, rounded to the second decimal before determining the sum.

<sup>F</sup> Vanadium 0.05 max.

<sup>G</sup> The aluminum content shall be calculated by subtracting from 100.00 % the sum of all the metallic elements present in amounts of 0.010 % or more, rounded to the second decimal before determining the sum.

<sup>H</sup> Composition of cladding alloy as applied during the course of manufacture. The sample from finished tube shall not be required to conform to these limits.

TABLE 2 Tensile Property Limits<sup>A,B</sup>

Alloy	Temper	Wall Thickness, in.	Tensile Strength, min, ksi	Yield Strength, (0.2 % Offset), min, ksi	Elongation in 2 in., or 4 × Dia, <sup>C</sup> min, %	
					Full-Section Specimen	Cut-Out Specimen
1060	H14	0.010–0.200	12.0	10.0	...	...
3003	H14	0.010–0.024	20.0	17.0	3	...
		0.025–0.049	20.0	17.0	5	3
	0.050–0.200	20.0	17.0	8	4	
	H25	0.010–0.200	22.0	19.0	...	...
Alclad 3003	H14	0.010–0.024	19.0	16.0	...	...
		0.025–0.049	19.0	16.0	5	3
	0.050–0.200	19.0	16.0	8	4	
	H25	0.010–0.200	21.0	18.0	...	...
5052	H32	0.010–0.200	31.0	23.0	...	...
	H34	0.010–0.200	34.0	26.0	...	...
5454	H32	0.010–0.050	36.0	26.0	...	5
		0.051–0.200	36.0	26.0	...	8
	H34	0.010–0.050	39.0	29.0	...	4
		0.051–0.200	39.0	29.0	...	6
6061	T4	0.025–0.049	30.0	16.0	16	14
		0.050–0.200	30.0	16.0	18	16
	T6	0.025–0.049	42.0	35.0	10	8
		0.050–0.200	42.0	35.0	12	10

<sup>A</sup> To determine conformance to this specification, each value for ultimate strength and for yield strength shall be rounded to the nearest 0.1 ksi and each value for elongation to the nearest 0.5 %, both in accordance with the rounding-off method of Practice E29.

<sup>B</sup> The basis for establishment of mechanical property limits is shown in Annex A1.

<sup>C</sup> Elongation of full-section and cut-out sheet-type specimens is measured in 2 in., of cut-out round specimens, in 4 × specimen diameter.

Chemical Composition by Spectrochemical Analysis  
E1251 Test Method for Analysis of Aluminum and Aluminum Alloys by Spark Atomic Emission Spectrometry  
2.3 *ANSI Standards:*  
H35.1/H35.1(M) Alloy and Temper Designation Systems for Aluminum

H35.2 Dimensional Tolerances for Aluminum Mill Products  
2.4 *Federal Standard:*  
Fed. Std. No. 123 Marking for Shipment (Civil Agencies)  
2.5 *Military Standard:*  
MIL-STD-129 Marking for Shipment and Storage

### 2.6 AMS Specification:

AMS 2772 Heat Treatment of Aluminum Alloy Raw Materials

### 2.7 EN Standard:

CEN EN 14242 Aluminum and Aluminum Alloys, Chemical Analysis, Inductively Coupled Plasma Optical Emission Spectral Analysis

## 3. Terminology

3.1 Refer to Terminology B881 for definitions of product terms used in this specification.

### 3.2 Definitions of Terms Specific to This Standard:

3.2.1 *capable of*—the term *capable of* as used in this specification means that the test need not be performed by the producer of the material. However, should testing by the purchaser establish that the material does not meet these requirements, the material shall be subject to rejection.

## 4. Ordering Information

4.1 Orders for material to this specification shall include the following information:

- 4.1.1 This specification designation (which includes the number, the year, and the revision letter, if applicable),
- 4.1.2 Quantity in pieces or pounds,
- 4.1.3 Alloy (Section 7),
- 4.1.4 Temper (Section 8),
- 4.1.5 Outside or inside diameter, wall thickness, and length,
- 4.1.6 For alloy Alclad 3003, state clad inside or outside (12.1).

4.2 Additionally, orders for material to this specification shall include the following information when required by the purchaser:

- 4.2.1 Whether heat treatment in accordance with Practice B918 is required (9.2),
- 4.2.2 Whether cut ends of tube are to be deburred (Section 14),
- 4.2.3 Whether inspection or witness of inspection and tests by the purchaser's representative is required prior to material shipment (Section 15),
- 4.2.4 DELETED
- 4.2.5 Whether marking for identification is required (Section 18), and
- 4.2.6 Whether Practices B660 applies and, if so, the level of preservation, packaging, and packing required (19.3).

## 5. Manufacture

5.1 The tube shall be produced by drawing an extruded tube made from hollow extrusion ingot (cast in hollow form or pierced) and extruded by use of the die and mandrel method.

## 6. Responsibility for Quality Assurance

6.1 *Responsibility for Inspection and Tests*—Unless otherwise specified in the contract or purchase order, the producer is

responsible for the performance of all inspection and test requirements specified herein. The producer may use his own or any other suitable facilities for the performance of the inspection and test requirements specified herein, unless disapproved by the purchaser in the order or at the time of contract signing. The purchaser shall have the right to perform any of the inspections and tests set forth in this specification where such inspections are deemed necessary to assure that material conforms to prescribed requirements.

6.2 *Lot Definition*—An inspection lot shall be defined as follows:

6.2.1 For heat-treated tempers, an inspection lot shall consist of an identifiable quantity of material of the same mill form, alloy, temper, and thickness traceable to a heat-treat lot or lots, and subjected to inspection at one time.

6.2.2 For nonheat-treated tempers, an inspection lot shall consist of an identifiable quantity of material of the same mill form, alloy, temper, and thickness subjected to inspection at one time.

## 7. Chemical Composition

7.1 *Limits*—The tube shall conform to the chemical composition limits in Table 1. Conformance shall be determined by the producer by analyzing samples taken at the time the ingots are poured in accordance with E716 and analyzed in accordance with E607, E1251, E34 or EN 14242. At least one sample shall be taken for each group of ingots poured from the same source of molten metal. If the producer has determined the chemical composition of the material during the course of manufacture, he shall not be required to sample and analyze the finished product.

NOTE 3—It is standard practice in the United States aluminum industry to determine conformance to the chemical composition limits prior to further processing of ingots into wrought products. Due to the continuous nature of the process, it is not practical to keep a specific ingot analysis identified with a specific quantity of finished material.

7.2 If it becomes necessary to analyze the finished or semifinished product for conformance to chemical composition limits, the method used to sample the finished or semifinished product for the determination of chemical composition shall be as agreed between the buyer and seller. Analysis shall be performed in accordance with E716, E607, E1251, E34, or EN 14242 (ICP method). The number of samples shall be as follows:

7.2.1 When samples are taken from the finished or semifinished product, a sample shall be taken to represent each 4000 lb or fraction thereof, of material in the lot, except that not more than one sample shall be required per piece.

7.2.2 Other methods of analysis, in the case of dispute, may be used by agreement between the producer and purchaser.

NOTE 4—It is difficult to obtain a reliable analysis of each of the components of clad materials using material in its finished state. A reasonably accurate determination of the core composition can be made if the cladding is substantially removed prior to analysis. The cladding composition is more difficult to determine because of the relatively thin layer and because of diffusion of core elements to the cladding. The correctness of cladding alloy used can usually be verified by a combination of metallographic examination and spectrochemical analysis of the surface at several widely separated points.

## 8. Tensile Properties of Material as Supplied

8.1 *Limits*—The tube shall conform to the tensile property requirements in Table 2.

### 8.2 Number of Specimens:

8.2.1 For material having a nominal weight of less than 1 lb/linear ft, one tension test specimen shall be taken for each 1000 lb, or fraction thereof, in the lot.

8.2.2 For material having a nominal weight of 1 lb or more/linear ft one tension test specimen shall be taken for each 1000 ft, or fraction thereof, in the lot.

8.2.3 Other procedures for selecting samples may be employed if agreed upon by the producer and the purchaser.

8.3 *Test Methods*—The tension tests shall be made in accordance with Test Methods B557.

## 9. Heat Treatment

9.1 Unless otherwise specified in 9.2, producer or supplier heat treatment for the applicable tempers in Table 2 shall be in accordance with AMS 2772.

9.2 When specified, heat treatment of applicable tempers in Table 2 shall be in accordance with Practice B918.

## 10. Leak Test

10.1 Each length of tube 1.5 in. or less in diameter shall be tested by either of the following methods, at the option of the producer or supplier, consistent with the size limitations indicated:

10.1.1 *Method 1*—Applicable to tube with a wall thickness of 0.200 in. max. Each tube shall be subjected to an internal air gage pressure of 250 psi for 5 s while immersed in a suitable liquid. Any evidence of leakage shall be cause for rejection.

10.1.2 *Method 2*—Applicable to tube with a wall thickness of 0.083 in. maximum, as covered by Practice E215. Each tube shall be subjected to an eddy current test in accordance with the procedures described in Practice E215. Reference standards described in Annex A1 and Annex A2 shall be used to standardize the equipment. These same reference standards or secondary standards having equivalent eddy current response shall also serve to define acceptance-rejection limits. Tubes that produce eddy current indications less than those from the 2A holes of the applicable reference standard or an equivalent secondary standard shall be acceptable. Any tube having a discontinuity that produces an eddy current indication equal to or greater than those from the 2A holes of the applicable reference standard or an equivalent secondary standard shall be rejected.

## 11. Expansion Test

11.1 The tube ends shall be capable of being flared, without showing cracks or ruptures visible to the unaided eye when corrected for normal vision, by forcing a steel pin having a taper of 1.5 in./ft into the tube until the inside diameter has been increased 20 %.

## 12. Cladding

12.1 The aluminum alloy cladding of Alclad 3003 tube shall, as specified, comprise either the inside surface (only) and

its thickness shall be approximately 10 % of the total wall thickness, or the outside surface (only) in which case its thickness shall be approximately 7 % of the total wall thickness.

12.2 When the thickness of the cladding is to be determined on finished tube, transverse cross sections of at least three tubes from the lot shall be polished for examination with a metallurgical microscope. Using a magnification of 100 $\times$ , the cladding thickness at four points, 90° apart, in each sample shall be measured and the average of all measurements shall be taken as the thickness. In the case of tubes having a diameter larger than can properly be mounted for polishing and examination, the portions of the cross section polished for examination may consist of an arc about 1/2 in. in length.

## 13. Dimensional Tolerances

13.1 Variations from the specified wall thickness, length, outside diameter, straightness, and squareness of cut ends shall not exceed the tolerances specified in the tables of ANSI H35.2 (see Table 3).

13.2 *Sampling for Inspection*—Examination for dimensional conformance shall be made to ensure conformance to the tolerance specified.

## 14. General Quality

14.1 Unless otherwise specified, the material shall be supplied in the mill finish and shall be uniform as defined by the requirements of this specification and shall be commercially sound. Any requirement not so covered is subject to negotiation between producer and purchaser.

14.2 Grinding to remove minor surface imperfections shall not be cause for rejection, provided the repaired area is within dimensional tolerances.

14.3 When so specified on the purchase order, the cut ends of each tube shall be deburred by the use of a wire wheel, file, or other suitable tool or device.

14.4 Each tube shall be examined to determine conformance to this specification with respect to general quality and identification marking. On approval of the purchaser however, the producer may use a system of statistical quality control for such examinations.

## 15. Source Inspection

15.1 If the purchaser desires that his representative inspect or witness the inspection and testing of the material prior to

TABLE 3 Tables of ANSI H35.2

Table No.	Title
12.36	Heat-Exchanger Tube Wall Thickness
12.37	Heat-Exchanger Tube Length
12.34	Heat-Exchanger Tube Outside Diameter, Heat-Treatable Tube
12.35	Heat-Exchanger Tube Outside Diameter, Non-Heat-Treatable Tube
12.38	Heat-Exchanger Tube Straightness
12.39	Heat-Exchanger Tube Squareness of Cut Ends

shipment, such agreement shall be made by the purchaser and producer as part of the purchase contract.

15.2 When such inspection or witness of inspection and testing is agreed upon, the producer shall afford the purchaser's representative all reasonable facilities to satisfy him that the material meets the requirements of this specification. Inspection and tests shall be conducted so there is no unnecessary interference with the producer's operations.

## 16. Retest and Rejection

16.1 If any material fails to conform to all of the applicable requirements of this specification, it shall be cause for rejection of the inspection lot.

16.2 When there is evidence that a failed specimen was not representative of the inspection lot and when no other sampling plan is provided or approved by the purchaser through the contract or purchase order, at least two additional specimens shall be selected to replace each test specimen that failed. All specimens so selected for retest shall meet the requirements of the specification or the lot shall be subject to rejection.

16.3 Material in which defects are discovered subsequent to inspection may be rejected.

16.4 If material is rejected by the purchaser, the producer or supplier is responsible only for replacement of the material to the purchaser. As much as possible of the rejected material shall be returned to the producer or supplier by the purchaser.

## 17. Certification

17.1 The producer or supplier shall furnish to the purchaser a certificate stating that each lot has been sampled, tested, and inspected in accordance with this specification, and has met the requirements. In addition, all test reports required by this specification shall be provided.

## 18. Identification Marking of Product

18.1 When specified in the contract or purchase order all material shall be marked in accordance with Practice B666/B666M.

18.2 The foregoing requirements are minimum; marking systems which involve added information, large characteristics, and greater frequencies are acceptable under this specification.

## 19. Packaging and Package Marking

19.1 The material shall be packaged to provide adequate protection during normal handling and transportation, and each package shall contain only one alloy, temper, and size of material unless otherwise agreed. The type of packaging and gross weight of containers shall, unless otherwise agreed upon, be at the producer's or supplier's discretion, provided that they are such as to ensure acceptance by common or other carriers for safe transportation at the lowest rate to the delivery point.

19.2 Each shipping container shall be marked with the purchase order number, material size, specification number, alloy and temper, gross and net weights, and the producer's name or trademark.

19.3 When specified in the contract or purchase order, material shall be preserved, packaged, and packed in accordance with the requirements of Practices B660. The applicable levels shall be as specified in the contract or order. Marking for shipment of such material shall be in accordance with Fed. Std. No. 123 for civil agencies and MIL-STD-129 for Military agencies.

## 20. Keywords

20.1 aluminum alloy; drawn seamless tubes; heat exchangers

## ANNEXES

### (Mandatory Information)

#### A1. BASIS FOR INCLUSION OF PROPERTY LIMITS

A1.1 Mechanical property limits are established in accord with Section 6, Standards Section, of the most current edition of the Aluminum Standards and Data and the latest edition of the Aluminum Association publication "Tempers for Aluminum and Aluminum Alloy Products (Yellow and Tan Sheets)."

A1.1.1 Limits are based on a statistical evaluation of the data indicating that at least 99 % of the population obtained from all standard material meets the limit with 95 % confidence. For the products described, mechanical property limits are based on the statistical analyses of at least 100 tests from at least 5 cast lots of standard production material with no more than 10 observations from a given heat treat or inspection lot. Mechanical properties limits for press solution heat treated

products have specific additional requirements which are provided in the "Tempers for Aluminum and Aluminum Alloy Products."

A1.1.2 Limits denoted as "Tentative" by the Aluminum Association may be included. Requirements for tentative property registrations are defined in the latest edition of the Aluminum Association publication "Tempers for Aluminum and Aluminum Alloy Products." Tentative property limits are established at levels at which at least 99 % of the data conform at a confidence level of 95 %. Tentative property limits, which are subject to revision, shall be based on a statistical analysis of at least 30 tests from at least 3 cast lots of standard production material with no more than 10 observations from a given heat

treat or inspection lot. Where tentative property limits are listed, they shall be shown in italics and footnoted as Tentative in the standard.

A1.1.3 All tests are performed in accordance with the appropriate ASTM test methods.

## A2. ACCEPTANCE CRITERIA FOR INCLUSION OF NEW ALUMINUM AND ALUMINUM ALLOYS IN THIS SPECIFICATION

A2.1 Prior to acceptance for inclusion in this specification, the composition of wrought or cast aluminum or aluminum alloy shall be registered in accordance with ANSI H35.1/H35.1(M). The Aluminum Association holds the Secretariat of ANSI H35 Committee and administers the criteria and procedures for registration.

A2.2 If it is documented that the Aluminum Association could not or would not register a given composition, an alternative procedure and the criteria for acceptance shall be as follows:

A2.2.1 The designation submitted for inclusion does not utilize the same designation system as described in ANSI H35.1/H35.1(M). A designation not in conflict with other designation systems or a trade name is acceptable.

A2.2.2 The aluminum or aluminum alloy has been offered for sale in commercial quantities within the prior twelve months to at least three identifiable users.

A2.2.3 The complete chemical composition limits are submitted.

A2.2.4 The composition is, in the judgment of the responsible subcommittee, significantly different from that of any other aluminum or aluminum alloy already in the specification.

A2.2.5 For codification purposes, an alloying element is any element intentionally added for any purpose other than grain

refinement and for which minimum and maximum limits are specified. Unalloyed aluminum contains a minimum of 99.00 % aluminum.

A2.2.6 Standard limits for alloying elements and impurities are expressed to the following decimal places:

Less than 0.001 %	0.000X
0.001 to but less than 0.01 %	0.00X
0.01 to but less than 0.10 %	
Unalloyed aluminum made by a refining process	0.0XX
Alloys and unalloyed aluminum not made by a refining process 0.10 through 0.55 %	0.0X
(It is customary to express limits of 0.30 through 0.55 % as 0.X0 or 0.X5.)	0.XX
Over 0.55 %	0.X, X.X, and so forth.

(except that combined Si + Fe limits for 99.00 % minimum aluminum must be expressed as 0.XX or 1.XX)

A2.2.7 Standard limits for alloying elements and impurities are expressed in the following sequence: Silicon; Iron; Copper; Manganese; Magnesium; Chromium; Nickel; Zinc (Note A2.1); Titanium; Other Elements, Each; Other Elements, Total; Aluminum (Note A2.2).

NOTE A2.1—Additional specified elements having limits are inserted in alphabetical order of their chemical symbols between zinc and titanium, or are specified in footnotes.

NOTE A2.2—Aluminum is specified as *minimum* for unalloyed aluminum and as a *remainder* for aluminum alloys.

## APPENDIX

### (Nonmandatory Information)

#### X1. GENERAL INFORMATION

X1.1 The following information does not constitute a part of this specification but is intended to assist in the proper selection and use of the materials.

X1.2 Alloys 1060, 3003, alclad 3003, 5052, and 5454 are supplied in a strain-hardened temper to meet the specified tensile and yield strengths. Alloy 6061 is supplied in the heat-treated temper (-T4) and in the heat-treated and aged temper (-T6): the -T4 temper is more workable, and after forming work is completed may be aged to the stronger -T6 temper. A typical aging treatment would be to hold the material at 340°F for 6 to 10 h in a suitable furnace and allow to cool at room temperature.

X1.3 Aluminum heat-exchanger tubes are resistant to most petroleum products and a large number of organic and inorganic chemicals. Aluminum is very resistant to hydrogen sulfide and carbon dioxide. Alloy alclad 3003 tubes are generally recommended in those heat-exchanger services where salt or fresh cooling waters within a pH range of 5 to 8 pass through the tubes. Waters with a pH outside of this range may or may not be corrosive, depending on what compounds present in the water contribute to the acidity or alkalinity.

ASMENORMDOC.COM : Click to view the full PDF of ASME BPVC.II.B (ASME BPVC Section II part B) 2025

INTENTIONALLY LEFT BLANK

# SPECIFICATION FOR ALUMINUM AND ALUMINUM-ALLOY SEAMLESS PIPE AND SEAMLESS EXTRUDED TUBE



**SB-241/SB-241M**



(25)

(Identical with ASTM Specification B241/B241M-22 except paras. 4.2.6, 4.2.7, 9.1.1.2, and 9.1.2 have been deleted; Note D for Tables 1 and 2 has been deleted; Note B for Table 5 has been deleted; certification and test report are mandatory; and T42 and T62 tempers are not permitted for ASME construction use (see Note F of Tables 1 and 2.)

*ASME SB-241/SB-241M replaces paras. 4.2.6 and 4.2.7 of ASTM 241/B241M with the following:*

4.2.6 DELETED

4.2.7 DELETED

*ASME SB-241/SB-241M, Tables 1 and 2 replace Notes D and F of ASTM 241/B241M, Tables 1 and 2 with the following:*

<sup>D</sup>DELETED

<sup>F</sup>T42 and T62 tempers are currently not permitted for ASME construction use.

*ASME SB-241/SB-241M replaces paras. 9.1.1.2 and 9.1.2 of ASTM 241/B241M with the following:*

9.1.1.2 DELETED

9.1.2 DELETED

ASME SB-241/SB-241M, Table 5 replaces Note B of ASTM 241/B241M, Table 5 with the following:

<sup>B</sup>DELETED

ASME SB-241/SB-241M, Table 8 replaces Note A of ASTM 241/B241M, Table 8 with the following:

<sup>A</sup>Sampling for electrical conductivity tests shall be the same as for tensile tests as specified in 9.2. Test specimens may be prepared by matching a flat, smooth surface of sufficient width for proper testing. For small sizes of tubes, a cut-out portion may be flattened and the conductivity determined on the surface. Milling may be used on flat surface samples. The electrical conductivity shall be determined in accordance with Practice E1004 in the following locations:

ASME SB-241/SB-241M replaces paras. 14.4 and 21.1 of ASTM 241/B241M with the following:

14.4 Nominal sizes and weights of 14, 16, 18, and 20-in. pipe are given in Table 3. Dimensional Tolerances for these sizes shall be agreed upon between the producer and purchaser and shall be specified in the contract or purchase order.

21.1 The supplier or producer shall furnish to the purchaser a certificate and test report stating that the material has been sampled, tested, and inspected in accordance with this specification, and has met the requirements.



Designation: B241/B241M – 22

## Standard Specification for Aluminum and Aluminum-Alloy Seamless Pipe and Seamless Extruded Tube<sup>1</sup>

This standard is issued under the fixed designation B241/B241M; the number immediately following the designation indicates the year of original adoption or, in the case of revision, the year of last revision. A number in parentheses indicates the year of last reapproval. A superscript epsilon ( $\epsilon$ ) indicates an editorial change since the last revision or reapproval.

*This standard has been approved for use by agencies of the U.S. Department of Defense.*

### 1. Scope\*

1.1 This specification<sup>2</sup> covers aluminum and aluminum–alloy seamless pipe and seamless extruded round tube in the alloys and tempers shown in Table 1 [Table 2] intended for pressure applications. The standard sizes for seamless pipe are listed in Table 16.7 of ANSI H35.2 and H35.2(M). Nonstandard alloys, tempers, and sizes of pipe are produced as seamless extruded tube. Also included in this standard are seamless extruded pipe and seamless extruded tube for Oil & Gas Transmission previously covered under Specification B345/B345M.

NOTE 1—Throughout this specification, use of the term *alloy*, in the general sense, includes aluminum as well as aluminum alloy.

NOTE 2—For drawn seamless tubes, see Specification B210/B210M; for extruded tubes, Specifications B221 and B221M; for drawn seamless tubes for condensers and heat exchangers, Specifications B234 and B234M; for seamless condenser and heat exchanger tubes with integral fins, Specification B429/B429M; and for drawn tube for general purpose applications, Specification B483/B483M.

1.2 Alloy and temper designations are in accordance with ANSI H35.1/H35.1(M). The equivalent Unified Numbering System alloy designations are those of Table 4 preceded by A9, for example, A91100 for aluminum 1100 in accordance with Practice E527.

1.3 For acceptance criteria for inclusion of new aluminum and aluminum alloys in this specification, see Annex A2.

1.4 The values stated in either SI units or inch-pound units are to be regarded separately as standard. The values stated in each system may not be exact equivalents; therefore, each system shall be used independently of the other. Combining values from the two systems may result in non-conformance with the standard.

1.4.1 The SI units are shown either in brackets or in separate tables.

1.5 *This international standard was developed in accordance with internationally recognized principles on standardization established in the Decision on Principles for the Development of International Standards, Guides and Recommendations issued by the World Trade Organization Technical Barriers to Trade (TBT) Committee.*

### 2. Referenced Documents

2.1 The following documents of the issue in effect on date of material purchase form a part of this specification to the extent referenced herein:

#### 2.2 ASTM Standards:<sup>3</sup>

- B210/B210M Specification for Aluminum and Aluminum-Alloy Drawn Seamless Tubes
- B221 Specification for Aluminum and Aluminum-Alloy Extruded Bars, Rods, Wire, Profiles, and Tubes
- B221M Specification for Aluminum and Aluminum-Alloy Extruded Bars, Rods, Wire, Profiles, and Tubes (Metric)
- B234 Specification for Aluminum and Aluminum-Alloy Drawn Seamless Tubes for Surface Condensers, Evaporators, and Heat Exchangers
- B234M Specification for Aluminum and Aluminum-Alloy Drawn Seamless Tubes for Surface Condensers, Evaporators, and Heat Exchangers (Metric)
- B429/B429M Specification for Aluminum-Alloy Extruded Structural Pipe and Tube
- B483/B483M Specification for Aluminum and Aluminum-Alloy Drawn Tube and Drawn Pipe for General Purpose Applications
- B557 Test Methods for Tension Testing Wrought and Cast Aluminum- and Magnesium-Alloy Products
- B557M Test Methods for Tension Testing Wrought and Cast Aluminum- and Magnesium-Alloy Products (Metric)

<sup>1</sup> This specification is under the jurisdiction of ASTM Committee B07 on Light Metals and Alloys and is the direct responsibility of Subcommittee B07.03 on Aluminum Alloy Wrought Products.

Current edition approved Oct. 1, 2022. Published November 2022. Originally approved in 1949. Last previous edition approved in 2016 as B241/B241M – 16. DOI: 10.1520/B0241\_B0241M-22.

<sup>2</sup> For ASME Boiler and Pressure Vessel Code applications see related specifications 241/SB241-241M/SB241M in Section II of that code.

<sup>3</sup> For referenced ASTM standards, visit the ASTM website, [www.astm.org](http://www.astm.org), or contact ASTM Customer Service at [service@astm.org](mailto:service@astm.org). For *Annual Book of ASTM Standards* volume information, refer to the standard's Document Summary page on the ASTM website.

B594 Practice for Ultrasonic Inspection of Aluminum-Alloy Wrought Products

B647 Test Method for Indentation Hardness of Aluminum Alloys by Means of a Webster Hardness Gage

B648 Test Method for Indentation Hardness of Aluminum Alloys by Means of a Barcol Impressor

B660 Practices for Packaging/Packing of Aluminum and Magnesium Products

B666/B666M Practice for Identification Marking of Aluminum and Magnesium Products

B807/B807M Practice for Extrusion Press Solution Heat Treatment for Aluminum Alloys

B881 Terminology Relating to Aluminum- and Magnesium-Alloy Products

B918/B918M Practice for Heat Treatment of Wrought Aluminum Alloys

B945 Practice for Aluminum Alloy Extrusions Press Cooled from an Elevated Temperature Shaping Process for Production of T1, T2, T5 and T10-Type Tempers

B985 Practice for Sampling Aluminum Ingots, Billets, Castings and Finished or Semi-Finished Wrought Aluminum Products for Compositional Analysis

E18 Test Methods for Rockwell Hardness of Metallic Materials

E29 Practice for Using Significant Digits in Test Data to Determine Conformance with Specifications

E527 Practice for Numbering Metals and Alloys in the Unified Numbering System (UNS)

E716 Practices for Sampling and Sample Preparation of Aluminum and Aluminum Alloys for Determination of Chemical Composition by Spark Atomic Emission Spectrometry

E1004 Test Method for Determining Electrical Conductivity Using the Electromagnetic (Eddy Current) Method

E1251 Test Method for Analysis of Aluminum and Aluminum Alloys by Spark Atomic Emission Spectrometry

E3061 Test Method for Analysis of Aluminum and Aluminum Alloys by Inductively Coupled Plasma Atomic Emission Spectrometry (Performance Based Method)

G47 Test Method for Determining Susceptibility to Stress-Corrosion Cracking of 2XXX and 7XXX Aluminum Alloy Products

2.3 *ANSI Standards:*

B2.1 Pipe Threads (except Dryseal)<sup>4</sup>

B36.10 Wrought Steel and Wrought Iron Pipe<sup>4</sup>

H35.1/H35.1(M) Alloy and Temper Designation Systems for Aluminum<sup>5</sup>

H35.2 Dimensional Tolerances for Aluminum Mill Products<sup>5</sup>

H35.2(M) Dimensional Tolerances for Aluminum Mill Products [Metric]<sup>5</sup>

<sup>4</sup> Available from American National Standards Institute, 11 West 42nd Street, 13th Floor, New York, NY 10036.

<sup>5</sup> Available from Aluminum Association, Inc., 1400 Crystal Dr., Suite 430, Arlington, VA 22202 <http://www.aluminum.org>.

2.4 *American Welding Society Standard*

D10.7 Recommended Practices for Gas Shielded Arc Welding of Aluminum and Aluminum-Alloy Pipe<sup>6</sup>

2.5 *Federal Standard:*

Fed. Std. No. 123 Marking for Shipment (Civil Agencies)<sup>7</sup>

2.6 *Military Standard:*

MIL-STD-129 Marking for Shipment and Storage<sup>7</sup>

2.7 *AMS Specification:*

AMS 2772 Heat Treatment of Aluminum Alloy Raw Materials<sup>8</sup>

2.8 *CEN EN Standards*

CEN EN 14242 Aluminum and Aluminum Alloys—Chemical Analysis—Inductively Coupled Plasma Optical Emission Spectral Analysis<sup>9</sup>

### 3. Terminology

#### 3.1 *Definitions of Terms Specific to This Standard:*

3.1.1 *alclad seamless pipe or alclad seamless round tube, n*—a composite pipe or tube product composed of a seamless aluminum alloy core having on either the inside or the outside surface a metallurgically bonded aluminum or aluminum-alloy coating that is anodic to the core, thus electrolytically protecting the core against corrosion.

3.1.2 *capable of, adj*—the test need not be performed by the producer of the material. However, should subsequent testing by the purchaser establish that the material does not meet these requirements, the material shall be subject to rejection.

3.1.3 *extruded seamless alclad tube, n*—a composite round tube product composed of an aluminum alloy core having on either the inside or outside surface a metallurgically bonded aluminum or aluminum alloy coating that is anodic to the core, thus electrolytically protecting the core against corrosion.

3.1.4 *extruded seamless pipe, n*—extruded seamless round tube with standardized sizes of outside diameter and wall thickness commonly designated by “Nominal Pipe Sizes” and American National Standards Institute (ANSI) “Schedule Numbers.”

3.1.5 *extruded seamless round tube, n*—a hollow product having a round cross section and a uniform wall thickness, brought to final dimensions by extruding from a hollow cast ingot or mandrel pierced ingot.

3.1.6 *producer, n*—the primary manufacturer of the material.

3.1.7 *seamless pipe, n*—extruded or drawn seamless tube having certain standardized sizes of outside diameter and wall thickness commonly designated by “Nominal Pipe Sizes” and American National Standards Institute (ANSI) “Schedule Numbers.”

<sup>6</sup> Available from the American Welding Society, 8669 NW 36th St, Miami, FL 33166.

<sup>7</sup> Available from Standardization Documents Order Desk, DODSSP, Bldg. 4, Section D, 700 Robbins Ave., Philadelphia, PA 19111-5098, <http://dodssp.daps.dla.mil>.

<sup>8</sup> Available from SAE International (SAE), 400 Commonwealth Dr., Warrendale, PA 15096-0001, <http://www.sae.org>.

<sup>9</sup> Available from European Committee for Standardization (CEN), 36 Rue de Stassart, B-1050, Brussels, Belgium, <http://www.cenorm.be>.

3.1.8 *supplier, n*—jobber or distributor as distinct from producer.

3.2 *Other Definitions*—For all other definitions of product terms, refer to Terminology B881.

#### 4. Ordering Information

4.1 Orders for material to this specification shall include the following information:

4.1.1 This specification designation (which includes the number, the year, and the revision letter, if applicable),

NOTE 3—For inch-pound orders specify Specification B241; for metric orders specify Specification B241M. Do not mix units.

4.1.2 Quantity in pieces or pounds [kilograms],

4.1.3 Alloy (Section 7),

4.1.4 Temper (Section 9),

4.1.5 Pipe size and schedule number (Table 12.55 of ANSI H35.2 and H35.2(M)), or outside diameter and wall thickness (tube). Dimensional tolerances for 14, 16, 18, and 20-in. pipe sizes (see Table 3) shall be agreed upon between the producer and purchaser and shall be specified by contract or purchase order.

4.1.6 For alloy Alclad 3003, state clad inside or outside (Section 13).

4.1.7 End configuration (Sections 15.4 and 15.5).

4.1.8 Length (Section 14).

4.2 Additionally, orders for material to this specification shall include the following information when required by the purchaser:

4.2.1 Whether solution treatment at the press is unacceptable (8.3),

4.2.2 Whether heat treatment in accordance with Practice B918/B918M is required (8.4),

4.2.3 Whether threaded ends are required (see 15.2),

4.2.4 Whether inspection or witness of inspection and tests by the purchaser's representative is required prior to material shipment (Section 16),

4.2.5 Whether Practices B660 applies and, if so, the levels of preservation, packaging, and packing required (20.3),

4.2.6 Whether certification of the material is required (Section 21),

4.2.7 Requirements for tensile property and dimensional tolerance for sizes not specifically covered (9.1.2 and 14.2),

4.2.8 Whether ultrasonic inspection is required (Section 16, Table 5 [Table 6]),

4.2.9 Whether Sections 10 and 11 apply to 6063 and 6061 alloys, and

4.2.10 Whether the term "Seamless" is required in product marking in accordance with Practice B666/B666M.

4.2.11 Whether hardness screening is required (10.3, Table 5 [Table 6]).

#### 5. Materials and Manufacture

5.1 The pipe and tube shall be produced from hollow extrusion ingot (cast in hollow form, or drilled, or pierced from solid ingot) and shall be extruded by use of the die and mandrel method.

5.1.1 At the option of the producer, the pipe and tube may be drawn after extrusion, provided all the requirements of this specification are met.

#### 6. Quality Assurance

6.1 *Responsibility for Inspection and Tests*—Unless otherwise specified in the contract or purchase order, the producer is responsible for the performance of all inspection and test requirements specified herein. The producer may use his own or any other suitable facilities for the performance of the inspection and test requirements specified herein, unless disapproved by the purchaser in the order or at the time of contract signing. The purchaser shall have the right to perform any of the inspections and tests set forth in this specification where such inspections and tests are deemed necessary to ensure that material conforms to prescribed requirements.

6.2 *Lot Definition*—An inspection lot shall be defined as follows:

6.2.1 For heat-treated tempers, an inspection lot shall consist of an identifiable quantity of material of the same mill form, alloy, temper, and nominal dimensions traceable to a heat-treat lot or lots, and subjected to inspection at one time.

6.2.2 For non-heat treated tempers, an inspection lot shall consist of an identifiable quantity of material of the same mill form alloy, temper, and nominal dimensions subjected to inspection at one time.

#### 7. Composition

7.1 *Limits*—The pipe or tube shall conform to the composition limits specified in Table 4. Conformance shall be determined by the producer, by taking samples in accordance with Practices E716, when the ingots are poured, and analyzing those samples in accordance with Test Methods E1251, E3061, or EN 14242. At least one sample shall be taken for each group of ingots poured simultaneously from the same source of molten metal. If the producer has determined the composition during pouring of the ingots, they shall not be required to sample and analyze the finished product.

7.2 If it becomes necessary to analyze the finished or semi-finished product for conformance to chemical composition limits, the methods of sampling and methods of analysis shall be as provided in the following:

7.2.1 *Methods of Sampling*—Samples for chemical analysis shall be taken in accordance with Practice B985.

7.2.2 *Methods of Analysis*—Analysis shall be performed in accordance with Test Methods E1251, E3061, or CEN EN 14242 (ICP method).

NOTE 4—It is standard practice in the United States aluminum industry to determine conformance to the composition limits prior to further processing of ingots into wrought products. Due to the continuous nature of the process, it is not practical to keep a specific ingot analysis identified with a specific quantity of finished material.

TABLE 1 Tensile Property Limits, Inch-Pound Units<sup>A,B</sup>

Temper	Specified Section or Wall Thickness, in.	Area, in. <sup>2</sup>	Tensile Strength, ksi		Yield Strength (0.2 % Offset), ksi		Elongation in 2 in. or 4 x Diameter, min, % <sup>C</sup>
			Min	Max	Min	Max	
Aluminum 1060							
O	all	all	8.5	14.0	2.5	...	25
H112	all	all	8.5	...	2.5	...	25
F <sup>D</sup>	all	all	...	...	...	...	...
Aluminum 1100							
O	all	all	11.0	15.5	3.0	...	25
H112	all	all	11.0	...	3.0	...	25
F <sup>D</sup>	all	all	...	...	...	...	...
Alloy 2014							
O	all	all	...	30.0	...	18.0	12
T4	all	all	50.0	...	35.0	...	12
T4510 <sup>E</sup>							
T4511 <sup>E</sup>							
T42 <sup>F,G</sup>	all	all	50.0	...	...	...	12
T6	up thru 0.499	all	60.0	...	...	...	7
T6510 <sup>E</sup>		all	64.0	...	...	...	7
T6511 <sup>E</sup>		up thru 25	68.0	...	...	...	7
		over 25 thru 32	68.0	...	...	...	6
T62 <sup>F,G</sup>	up thru 0.749	all	60.0	...	...	...	7
	0.750 and over	up thru 25	60.0	...	...	...	7
		over 25 thru 32	60.0	...	...	...	6
F <sup>D</sup>	all	all	...	...	...	...	...
Alloy 2024							
O	all	all	...	35.0	...	19.0	12
T3	up thru 0.249	all	57.0	...	...	...	10
T3510 <sup>E</sup>		all	60.0	...	...	...	10
T3511 <sup>E</sup>		all	65.0	...	...	...	10
	1.500 and over	up thru 25	70.0	...	...	...	10
		over 25 thru 32	68.0	...	...	...	8
T42 <sup>F,G</sup>	up thru 0.749	all	57.0	...	...	...	12
	0.750-1.499	all	57.0	...	...	...	10
	1.500 and over	up thru 25	57.0	...	...	...	10
		over 25 thru 32	57.0	...	...	...	8
T81	0.050-0.249	all	64.0	...	...	...	4
T8510 <sup>E</sup>	0.250-1.499	all	66.0	...	...	...	5
T8511 <sup>E</sup>	1.500 and over	up thru 32	66.0	...	...	...	5
F <sup>D</sup>	all	all	...	...	...	...	...
Alloy 2219							
O	all	all	...	32.0	...	18.0	12
T31	up thru 0.499	up thru 25	42.0	...	...	...	14
T3510 <sup>E</sup>		up thru 25	45.0	...	...	...	14
T3511 <sup>E</sup>	0.500-2.999						

TABLE 1 Continued

Temper	Specified Section or Wall Thickness, in.	Area, in. <sup>2</sup>	Tensile Strength, ksi		Yield Strength (0.2 % Offset), ksi		Elongation in 2 in. or 4 x Diameter, min, % <sup>C</sup>						
			Min	Max	Min	Max							
T62 <sup>F, G</sup>	up thru 0.999	up thru 25	54.0	...	36.0	...	6						
	1.000 and over	up thru 25	54.0	...	36.0	...	6						
T81 T8510 <sup>E</sup> T8511 <sup>E</sup>	up thru 2.999	up thru 25	58.0	...	42.0	...	6						
F <sup>D</sup>								all	all	...	...	...	...
Alloy 3003													
O	all	all	14.0	19.0	5.0	...	25						
H112	all	all	14.0	...	5.0	...	25						
F <sup>D</sup>	all	all	...	...	...	...	...						
Alclad Alloy 3003													
O	all	all	13.0	18.0	4.5	...	25						
H112	all	all	13.0	...	4.5	...	25						
F <sup>D</sup>	all	all	...	...	...	...	...						
Alloy 5052													
O	all	all	25.0	35.0	10.0	...	...						
F <sup>D</sup>	all	all	...	...	...	...	...						
Alloy 5083													
O	all	up thru 32	39.0	51.0	16.0	...	14						
H111	all	up thru 32	40.0	...	24.0	...	12						
H112	all	up thru 32	39.0	...	16.0	...	12						
F <sup>D</sup>	all	all	...	...	...	...	...						
Alloy 5086													
O	all	up thru 32	35.0	46.0	14.0	...	14						
H111	all	up thru 32	36.0	...	21.0	...	12						
H112	all	up thru 32	35.0	...	14.0	...	12						
F <sup>D</sup>	all	all	...	...	...	...	...						
Alloy 5154													
O	all	all	30.0	41.0	11.0	...	...						
H112	all	all	30.0	...	11.0	...	...						
Alloy 5454													
O	all	up thru 32	31.0	41.0	12.0	...	14						
H111	all	up thru 32	33.0	...	19.0	...	12						
H112	all	up thru 32	31.0	...	12.0	...	12						
F <sup>D</sup>	all	all	...	...	...	...	...						
Alloy 5456													
O	all	up thru 32	41.0	53.0	19.0	...	14						
H111	all	up thru 32	42.0	...	26.0	...	12						
H112	all	up thru 32	41.0	...	19.0	...	12						
F <sup>D</sup>	all	all	...	...	...	...	...						
Alloy 6005													
T1	up thru 0.500	all	25.0	...	15.0	...	16						
T5	up thru 0.124	all	38.0	...	35.0	...	8						
	0.125–1.000	all	38.0	...	35.0	...	10						
Alloy 6005A													
T1	up thru 0.249	all	25.0	...	14.5	...	15						
T5	up thru 0.249	all	38.0	...	31.0	...	7						
	0.250–0.999	all	38.0	...	31.0	...	9						
T61	up thru 0.249	all	38.0	...	35.0	...	8						
	0.250–1.000	all	38.0	...	35.0	...	10						

TABLE 1 Continued

Temper	Specified Section or Wall Thickness, in.	Area, in. <sup>2</sup>	Tensile Strength, ksi		Yield Strength (0.2 % Offset), ksi		Elongation in 2 in. or 4 x Diameter, min, % <sup>C</sup>
			Min	Max	Min	Max	
Alloy 6013							
T6, T6511	0.200-0.499	all	49.0		46.0		8
	0.500-0.749	all	49.0		46.0		8
	0.750-2.000	all	49.0		45.0		8
Alloy 6026							
T6, T6510 T6511	0.400-1.300	all	49.0		38.0		8
Alloy 6041							
T6, T6511	0.400-2.000	all	45.0		40.0		10
Alloy 6042							
T5, T5511	0.400-0.499	all	38.0		35.0		10
	0.500-1.800	all	42.0		35.0		10
Alloy 6061							
O	all	all	...	22.0	...	16.0	16
T1	up thru 0.625	all	26.0	...	14.0	...	16
T4 T4510 <sup>E</sup> T4511 <sup>E</sup> }	all	all	26.0	...	16.0	...	16
T42 <sup>F, G</sup>	all	all	26.0	...	12.0	...	16
T51	up thru 0.625	all	35.0	...	30.0	...	8
T6, T62 <sup>F, G</sup> T6510 <sup>E</sup> T6511 <sup>E</sup> }	up thru 0.249 0.250 and over	all all	38.0 38.0	... ...	35.0 35.0	... ...	8 10
F <sup>D</sup>	all	all	...	...	...	...	...
Alloy 6063							
O	all	all	...	19.0	...	...	18
T1 <sup>H</sup>	up thru 0.500	all	17.0	...	9.0	...	12
	0.501-1.000	all	16.0	...	8.0	...	12
T4, T42 <sup>F, G</sup>	up thru 0.500	all	19.0	...	10.0	...	14
	0.501-1.000	all	18.0	...	9.0	...	14
T5	up thru 0.500	all	22.0	...	16.0	...	8
	0.501-1.000	all	21.0	...	15.0	...	8
T52	up thru 1.000	all	22.0	30.0	16.0	25.0	8
T6, T62 <sup>F, G</sup> F <sup>D</sup>	up thru 0.124	all	30.0	...	25.0	...	8
	0.125-1.000	all	30.0	...	25.0	...	10
	all	all	...	...	...	...	...
Alloy 6064							
T6, T6511	0.400-2.000	all	42.0		38.0		10
Alloy 6066							

TABLE 1 Continued

Temper	Specified Section or Wall Thickness, in.	Area, in. <sup>2</sup>	Tensile Strength, ksi		Yield Strength (0.2 % Offset), ksi		Elongation in 2 in. or 4 x Diameter, min, % <sup>C</sup>
			Min	Max	Min	Max	
O	all	all	...	29.0	...	18.0	16
T4, T4510 <sup>E</sup> T4511 <sup>E</sup>	all	all	40.0	...	25.0	...	14
T42 <sup>F, G</sup>	all	all	40.0	...	24.0	...	14
T6, T6510, <sup>E</sup> T6511 <sup>E</sup>	all	all	50.0	...	45.0	...	8
T62 <sup>F, G</sup>	all	all	50.0	...	42.0	...	8
Alloy 6070							
T6, T62 <sup>F, G</sup>	up thru 2.999	up thru 32	48.0	...	45.0	6	5
Alloy 6082							
T6	0.200–1.000	all	45.0	...	38.0	...	8
Alloy 6105							
T1	up thru 0.500	all	25.0	...	15.0	...	16
T5	up thru 0.500	all	38.0	...	35.0	...	8
Alloy 6162							
T5, T5510 <sup>E</sup> T5511 <sup>E</sup>	up thru 1.000	all	37.0	...	34.0	...	7
T6, T6510 <sup>E</sup> T6511 <sup>E</sup>	up thru 0.249	all	38.0	...	35.0	...	8
	0.250–0.499	all	38.0	...	35.0	...	10
Alloy 6262							
T6, T6511	all	all	38.0	...	35.0	...	10
Alloy 6351							
T4 T6	up thru 0.749	all	32.0	...	19.0	...	16
	up thru 0.124	...	42.0	...	37.0	...	8
	0.125–0.749	...	42.0	...	37.0	...	10
Alloy 7075							
O	all	...	...	40.0	...	24.0	10
T6, T62 <sup>F, G</sup> T6510 <sup>E</sup> T6511 <sup>E</sup>	up through 0.249	all	78.0	...	70.0	...	7
	0.250–0.499	all	81.0	...	73.0	...	7
	0.500–1.499	all	81.0	...	72.0	...	7
T73 T73510 T73511	1.500–2.999	all	81.0	...	72.0	...	7
	0.062–0.249	all	68.0	...	58.0	...	7
	0.250–1.499	up thru 25	70.0	...	61.0	...	8
T73511	1.500–2.999	up thru 25	69.0	...	59.0	...	8
	...	...	...	...	...	...	...
F <sup>D</sup>	all	all	...	...	...	...	...

<sup>A</sup> The basis for establishment of mechanical property limits is shown in Annex A1.

<sup>B</sup> To determine conformance to this specification, each value for ultimate strength and for yield strength shall be rounded to the nearest 0.1 ksi and each value for elongation to the nearest 0.5 %, both in accordance with the rounding-off-method of Practice E29.

<sup>C</sup> Elongation of full-section and cut-out sheet-type specimens is measured in 2 in.; for round specimens, in 4 × specimen diameter. See 9.1.1 for conditions under which measurements are not required.

<sup>D</sup> No mechanical properties are specified, guaranteed, or provided.

<sup>E</sup> For stress relieved tempers (T3510, T3511, T4510, T4511, T5510, T5511, T6510, T6511, T73510, T73511, T8510, T8511), characteristics and properties other than those specified may differ somewhat from the corresponding characteristics and properties of material in the basic tempers.

<sup>F</sup> While material in the T42 and T62 tempers is not available from the material producer, the properties are listed to indicate those which can usually be obtained by the user when the material is properly solution heat treated or solution and precipitation heat treated from the O (annealed) or F (as-fabricated) tempers. These properties apply when samples of material supplied in the O or F temper are heat treated by the producer to the T42 or T62 tempers to determine that the material will respond to proper thermal treatment. Properties attained by the user, however, may be lower than those listed if the material has been formed or otherwise cold or hot worked, particularly in the annealed temper, prior to solution heat treatment.

<sup>G</sup> Material in the T42 and T62 tempers is not available from the material producers.

<sup>H</sup> Formerly designated T42 temper. When properly aged (precipitation heat-treated) 6063-T1 extruded products are designated T5.

NOTE 5—It is difficult to obtain a reliable analysis of each of the components of clad materials using material in its finished state. A reasonably accurate determination of the core composition can be made if the cladding is substantially removed prior to analysis. The cladding composition is more difficult to determine because of the relatively thin layer and because of diffusion of core elements to the cladding. The correctness of cladding alloy used can usually be verified by a combination of metallographic examination and spectrochemical analysis of the surface at several widely separated points.

## 8. Heat Treatment

8.1 For the production of T1, T2, T5, and T10-type tempers, producer or supplier heat treatment shall be in accordance with Practice B945.

8.2 For the production of T3, T4, T6, T7, and T8-type tempers, except as noted in 8.3 or 8.4, shall be in accordance with AMS 2772.

8.3 Unless otherwise specified (4.2.1), alloys 6005A, 6041, 6061, 6063, 6064, 6162, 6082, and 6351 may be solution heat treated and quenched at the extrusion press in accordance with Practice B807/B807M for the production of T3, T4, T6, T7, T8, and T9-type tempers, as applicable.

8.4 When specified (4.2.2), heat treatment for the production of T3, T4, T6, T7, T8, and T9-type tempers shall be in accordance with Practice B918/B918M.

## 9. Tensile Properties

9.1 *Limits*—The material shall conform to the tensile property requirements specified in Table 1 [Table 2] as applicable.

9.1.1 The elongation requirements shall not be applicable to the following:

9.1.1.1 Material of such dimensions that a standard test specimen cannot be taken in accordance with Test Methods B557 [B557M].

9.1.1.2 Tubes less than 0.062 in. [up through 1.60 mm] in wall thickness.

9.1.2 Tensile property limits for sizes not covered in Table 1 [Table 2] shall be as agreed upon between the producer and purchaser and shall be so specified in the contract or purchase order.

### 9.2 Number of Specimens:

9.2.1 For material having a nominal weight of less than 1 lb/linear ft [up through 1.7 kg/linear m], one tension test specimen shall be taken for each 1000 lb [500 kg] or fraction thereof in the lot.

9.2.2 For material having a nominal weight of 1 lb or more/linear ft [over 1.7 kg/linear m], one tension test specimen shall be taken for each 1000 ft [300 m] or fraction thereof in the lot.

9.2.3 Other procedures for selecting samples may be employed if agreed upon by the producer and the purchaser.

9.3 *Test Methods*—The tension tests shall be made in accordance with Test Methods B557 [B557M].

## 10. Producer Confirmation of Heat Treatment Response

10.1 The producer shall determine that heat treatable alloys supplied in the O or F tempers (within the size limits specified in Table 1 [Table 2]) respond to heat treatment in accordance with the following:

10.1.1 Alloys 2014 and 2024 shall, after proper solution heat treatment and natural aging for not less than four days at room temperature, conform to the properties specified in Table 1 [Table 2] for T42 temper material. The heat-treated samples may be tested prior to four days natural aging but if they fail to conform to the T42 temper properties, the tests may be repeated after completion of the four days natural aging without prejudice. Alloys 6061 and 6063 may be required to meet the same requirements per 4.2.9, ordering information, when required by the purchase agreement.

10.1.2 Alloys 2024, 2219, and 7075 shall, after proper solution heat treatment and precipitation heat treatment, conform to the properties specified in Table 1 [Table 2] for T62 temper material. Alloys 6061 and 6063 may be required to meet the same requirements per 4.2.9, ordering information, when required by the purchase agreement.

10.2 *Number of Specimens*—The number of specimens from each lot of O and F temper material shall be as specified in 9.2.

10.3 *Quality Assurance Screening of Extrusion Press Heat Treated Pipe and Tube*—Pipe and tube heat-treated at the extrusion press shall conform to all the requirements of Section 9. When specified (4.2.11), hardness tests shall be performed on each extruded length or, with the approval of the purchaser, on samples selected in accordance with a mutually agreeable sampling plan. The minimum hardness control value shall be in accordance with Table 5 [Table 6] for tube and pipe for the type of hardness tester used. The specific type of hardness tester shall be left to the discretion of the producer, but the test method shall be in accordance with Test Methods B647, B648, or E18, as applicable.

TABLE 2 Tensile Property Limits [SI Units]<sup>A,B</sup>

Temper	Specified Section or Wall Thickness, mm		Area, mm <sup>2</sup>		Tensile Strength, MPa		Yield Strength (0.2 % offset), MPa		Elongation, <sup>C</sup> %, min										
	over	through	over	through	min	max	min	max	in 50 mm	in 5 × diameter or 5.65√A									
Aluminum 1060																			
O	all		all		60	95	15	...	25	22									
H112	all		all		60	...	15	...	25	22									
F <sup>D</sup>	all		all		...	...	...	...	...	...									
Aluminum 1100																			
O	all		all		75	105	20	...	25	22									
H112	all		all		75	...	20	...	25	22									
F <sup>D</sup>	all		all		...	...	...	...	...	...									
Alloy 2014																			
O	all		all		...	205	...	125	12	10									
T4	all		all		345	...	240	...	12	10									
T4510 <sup>F</sup>	}		all		345	...	240	...	12	10									
T4511 <sup>E</sup>																			
T42 <sup>F, G</sup>	all		all		345	...	200	...	12										
T6	}	12.50	all		415	...	365	...	7	6									
T6510 <sup>F</sup>											18.00	18.00	all	440	...	400	...	6	
T6511 <sup>E</sup>											18.00	...	...	16 000	470	...	415	...	6
	}	18.00	all	16 000	470	...	400	...	...	5									
											18.00	...	...	20 000	470	...	400	...	
T62 <sup>F, G</sup>	}	18.00	all	...	415	...	365	...	7	6									
											18.00	...	...	16 000	415	...	365	...	6
											18.00	...	16 000	20 000	415	...	365	...	5
F <sup>D</sup>	all		all		...	...	...	...	...	...									
Alloy 2024																			
O	all		all		...	240	...	130	12	10									
T3	}	6.30	all		395	...	290	...	10	...									
T3510 <sup>F</sup>											18.00	18.00	all	415	...	305	...	10	9 <sup>H</sup>
T3511 <sup>E</sup>											18.00	35.00	all	450	...	315	...	...	9
											35.00	...	...	16 000	485	...	330	...	9
											35.00	...	16 000	20 000	470	...	315	...	7
T42 <sup>F, G</sup>	}	18.00	all	...	395	...	260	...	12	10									
											35.00	35.00	all	395	...	260	...	...	9
											35.00	...	...	16 000	395	...	260	...	9
											35.00	...	16 000	20 000	395	...	260	...	7
T81	}	6.30	all		440	...	385	...	4	...									
T8510 <sup>E</sup>											35.00	35.00	all	455	...	400	...	5	4
T8511 <sup>E</sup>											35.00	...	...	20 000	455	...	400	...	4
F <sup>D</sup>	all		all		...	...	...	...	...	...									
Alloy 2219																			
O	all		all		...	220	...	125	12	10									

TABLE 2 Continued

Temper	Specified Section or Wall Thickness, mm		Area, mm <sup>2</sup>		Tensile Strength, MPa		Yield Strength (0.2 % offset), MPa		Elongation, <sup>C</sup> %, min	
	over	through	over	through	min	max	min	max	in 50 mm	in 5 × diameter or 5.65√A
T31	...	12.50	...	16 000	290	...	180	...	14	12
T3510 <sup>E</sup>	}	12.50	80.00	16 000	310	...	185	...	...	12
T3511 <sup>E</sup>										
T62 <sup>F, G</sup>	}	25.00	...	16 000	370	...	250	...	6	5
			...	20 000	370	...	250	...	...	5
T81	}	80.00	...	16 000	400	...	290	...	6	5
T8510 <sup>E</sup>										
T8511 <sup>E</sup>										
F <sup>D</sup>	all		all		...	...	...	...	...	...
Alloy 3003										
O	all	...	all		95	130	35	...	25	22
H112	...		all		95	...	35	...	25	22
F <sup>D</sup>	all		all		...	...	...	...	...	...
Alclad Alloy 3003										
O	all		all		90	125	30	...	25	22
H112	all		all		90	...	30	...	25	22
F <sup>D</sup>	all		all		...	...	...	...	...	...
Alloy 5052										
O	all		all		170	240	70	...	...	...
F <sup>D</sup>	all		all		...	...	...	...	...	...
Alloy 5083										
O	all		...	20 000	270	350	110	...	14	12
H111	all		...	20 000	275	...	165	...	12	10
H112	all		...	20 000	270	...	110	...	12	10
F <sup>D</sup>	all		all		...	...	...	...	...	...
Alloy 5086										
O	all		...	20 000	240	315	95	...	14	12
H111	all		...	20 000	250	...	145	...	12	10
H112	all		...	20 000	240	...	95	...	12	10
F <sup>D</sup>	all		all		...	...	...	...	...	...
Alloy 5154										
O	all		all		205	285	75	...	...	...
H112	all		all		205	...	75	...	...	...
Alloy 5454										
O	all		...	20 000	215	285	85	...	14	12
H111	all		...	20 000	230	...	130	...	12	10
H112	all		...	20 000	215	...	85	...	12	10
F <sup>D</sup>	all		all		...	...	...	...	...	...
Alloy 5456										
O	all		...	20 000	285	365	130	...	14	12
H111	all		...	20 000	290	...	180	...	12	10
H112	all		...	20 000	285	...	130	...	12	10
F <sup>D</sup>	all		all		...	...	...	...	...	...

ASME BPVC Section II part B) 2025  
 Click to view the full PDF of ASME BPVC.II.B (ASME BPVC Section II part B) 2025

TABLE 2 Continued

Temper	Specified Section or Wall Thickness, mm		Area, mm <sup>2</sup>		Tensile Strength, MPa		Yield Strength (0.2 % offset), MPa		Elongation, <sup>C</sup> %, min	
	over	through	over	through	min	max	min	max	in 50 mm	in 5 × diameter or 5.65√A
Alloy 6005										
T1	...	12.50	all		170	...	105	...	16	14
T5	...	3.20			260	...	240	...	8	...
	3.20	25.00			260	...	240	...	10	9
Alloy 6005A										
T1	...	6.30	all		170	...	100	...	15	
T5	...	6.30	all		260	...	215	...	7	
	6.30	25.00	all		260	...	215	...	9	8
T61	...	6.30	all		260	...	240	...	8	
	6.30	25.00	all		260	...	240	...	10	9
Alloy 6013										
T6, T6511	5.00	12.50	all		340		315		8	...
	12.50	20.00	all		340		315		...	7
	20.00	50.00			340		310		...	7
Alloy 6026										
T6, T6510 T6511	10.00	30.00	all		340		260		6	8
Alloy 6041										
T6, T6511	10.00	50.00			310	...	275	...	10	9
Alloy 6042										
T5, T5511	10.00	12.50	all		260	...	240	...	10	
	12.50	50.00	all		290	...	240	...		9
Alloy 6061										
O	all		all		...	150	...	110	16	14
T1	...	16.00	all		180	...	95	...	16	14
T4			all		180	...	110	...	16	14
T4510 <sup>F</sup>	}	all								
T4511 <sup>E</sup>										
T42 <sup>F, G</sup>	all		all		180	...	85	...	16	14
T51	...	16.00	all		240	...	205	...	8	7
T6, T62 <sup>F, G</sup>	}	6.30	all		260	...	240	...	8	...
T6510 <sup>E</sup>										
T6511 <sup>E</sup>										
		...	all		260	...	240	...	10	9
F <sup>D</sup>	all		all		...	...	...	...	...	...
Alloy 6063										
O	all		all		...	130	...	...	18	16
T1	...	12.50	all	...	115	...	60	...	12	10
	12.50	25.00	all	...	110	...	55	...	...	10
T4, T42 <sup>F, G</sup>	...	12.50	all		130	...	70	...	14	12
	12.50	25.00	all		125	...	60	...	...	12

TABLE 2 Continued

Temper	Specified Section or Wall Thickness, mm		Area, mm <sup>2</sup>		Tensile Strength, MPa		Yield Strength (0.2 % offset), MPa		Elongation, <sup>C</sup> %, min	
	over	through	over	through	min	max	min	max	in 50 mm	in 5 × diameter or 5.65√A
T5	...	12.50	all		150	...	110	...	8	7
	12.50	25.00	all		145	...	105	...	...	7
T52	...	25.00	all		150	205	110	170	8	7
T6	...	3.20	all		205	...	170	...	8	...
	3.20	25.00	all		205	...	170	...	10	9
F <sup>D</sup>	all		all		...	...	...	...	...	...
Alloy 6064										
T6, T6511	10.00	50.00			290		240		10	9
Alloy 6066										
O T4,	all		all		...	200	...	125	16	14
T4510 <sup>E</sup>	}	all	all		275	...	170	...	14	12
T4511 <sup>E</sup>										
T42	}	all	all		275	...	165	...	14	12
T6, T6510 <sup>E</sup>										
T6511 <sup>E</sup>	all		all		345		310		8	7
T62	all		all		345	...	290	...	8	7
Alloy 6070										
T6, T62 <sup>F, G</sup>	80.00		20.000		330		310		6	5
Alloy 6082										
T6	5.00	25.00			310		260		8	10 <sup>H</sup>
Alloy 6105										
T1	...	12.50	all		170	...	105	...	16	14
T5	...	12.50	all		260	...	240	...	8	7
Alloy 6162										
T5,	}	25.00	all		255	...	235	...	7	6
T5510 <sup>E</sup>										
T5511 <sup>E</sup>										
T6,	}	6.30	all		260	...	240	...	8	...
T6510 <sup>E</sup>		6.30	12.50	all		260	...	240	...	10
T6511 <sup>E</sup>										
Alloy 6262										
T6, T6511	all		all		260	...	240	...	10	9
Alloy 6351										
T4	...	20.00	all		220	...	130	...	16	14
T6	...	3.20	...		290	...	255	...	8	...
	3.20	25.00	...		290	...	255	...	10	9

ASMENGDDOC.COM · Click to view the full PDF of ASME BPVC.II.B (ASME BPVC Section II part B) 2025

TABLE 2 Continued

Temper	Specified Section or Wall Thickness, mm		Area, mm <sup>2</sup>		Tensile Strength, MPa		Yield Strength (0.2 % offset), MPa		Elongation, <sup>C</sup> %, min	
	over	through	over	through	min	max	min	max	in 50 mm	in 5 × diameter or 5.65√A
Alloy 7075										
O	all		all		...	275	...	165	10	9
T6, T62 <sup>F, G</sup>	...	6.30	all		540	...	485	...	7	...
T6510 <sup>E</sup>	6.30	12.50	all		560	...	505	...	7	6
T6511 <sup>E</sup>	12.50	70.00	all		560	...	495	...	...	6
T73	1.60	6.30	all	13 000	470	...	400	...	7	...
T73510 <sup>E</sup>	6.30	35.00		16 000	485	...	420	...	8	7
	35.00	70.00		16 000	475	...	405	...	...	7
T73511 <sup>E</sup>										
F <sup>D</sup>	all		all		...	...	...	...	...	...

<sup>A</sup> The basis for establishment of tensile property limits is shown in Annex A1.

<sup>B</sup> To determine conformance to this specification, each value for tensile strength and yield strength shall be rounded to the nearest 1 MPa and each value for elongation to the nearest 0.5 %, both in accordance with the rounding-off method of Practice E29.

<sup>C</sup> Elongation in 50 mm apply for shapes tested in full section and for sheet-type specimens machined from material up through 12.5 mm in thickness having parallel surfaces. Elongations in 5 *D* (5.65√*A*), where *D* and *A* are diameter and cross-sectional area of the specimen respectively, apply to round test specimens machined from thicknesses over 6.30. See 9.1.1 for conditions under which measurements are not required.

<sup>D</sup> No mechanical properties are specified, guaranteed, or provided.

<sup>E</sup> For stress-relieved tempers (T3510, T3511, T4510, T4511, T5510, T5511, T6510, T6511, T73510, T73511, T76510, T76511, T8510, T8511), characteristics and properties other than those specified may differ somewhat from the corresponding characteristics and properties of material in the basic tempers.

<sup>F</sup> While material in the T42 and T62 tempers is not available from the material producer, the properties are listed to indicate those which can usually be obtained by the user when the material is properly solution heat treated or solution and precipitation heat treated from the O (annealed) or F (as-fabricated) tempers. These properties apply when samples of material supplied in the O or F temper are heat treated by the producer to the T42 or T62 tempers to determine that the material will respond to proper thermal treatment. Properties attained by the user, however, may be lower than those listed if the material has been formed or otherwise cold or hot worked, particularly in the annealed temper, prior to solution heat treatment.

<sup>G</sup> Material in the T42 and T62 tempers is not available from the material producer.

<sup>H</sup> For Table 12.1 in both ASD and ASD(M):

For purposes of harmonization, the 5D and 50 mm elongation limits were established to match extruded tube elongation values previously published in EN 755-2 [1997]. The relationship among the US customary and metric elongation values does not comply with the conversion rules of the Aluminum Association.

TABLE 3 Nominal Size and Weight<sup>A</sup> of Aluminum-Alloy Pipe<sup>D</sup>

Nominal Pipe Size, in. <sup>B</sup>	Schedule Number <sup>C</sup>	Nominal Outside Diameter, in. [mm]	Nominal Wall Thickness, in. [mm]	Nominal Weight per Foot, lb (kg/m) <sup>A</sup>
14	10	14.000 [356]	0.250 [6.35]	12.70 [18.83]
	20		0.312 [7.92]	15.78 [23.38]
	30		0.375 [9.52]	18.88 [27.98]
	40		0.438 [11.13]	21.95 [32.56]
	60		0.594 [15.04]	29.42 [43.50]
	80		0.750 [19.05]	36.71 [54.45]
	16		10	16.000 [406]
20		0.312 [7.92]	18.08 [26.74]	
30		0.375 [9.52]	21.65 [32.02]	
40		0.500 [12.70]	28.63 [42.37]	
60		0.656 [16.66]	37.19 [55.02]	
80		0.844 [21.44]	47.26 [69.94]	
18		40	18.000 [457]	
	20	40		20.000 [508]

<sup>A</sup> Based on density of 0.098 lb/in.<sup>3</sup> [270].

<sup>B</sup> Other pipe sizes with outside diameters listed in Table 2 of ANSI B36.10 may be considered covered by this specification if agreed upon between the producer and the purchaser.

<sup>C</sup> ANSI B36.10.

<sup>D</sup> Large size pipe previously covered under Specification B345/B345M.

10.3.1 Individual pieces within a lot that fail to conform to the minimum applicable hardness values may be accepted provided that samples from the two pieces exhibiting the

lowest minimum hardness values are tension tested and found to conform to the requirements of Table 1 [Table 2].

TABLE 4 Composition Limits<sup>A,B,C,D</sup>

Alloy	Silicon	Iron	Copper	Manganese	Magnesium	Chromium	Zinc	Titanium	Bi	Lead	Tin	Other Elements <sup>E</sup>		Aluminum
												Each	Total <sup>F</sup>	
1060	0.25	0.35	0.05	0.03	0.03	...	0.05	0.03	...	...	...	0.03 <sup>G</sup>	...	99.60 min <sup>H</sup>
1100	0.95 Si + Fe		0.05–0.20	0.05	...	...	0.10	...	...	...	...	0.05	0.15	99.00 min <sup>H</sup>
2014	0.50–1.2	0.7	3.9–5.0	0.40–1.2	0.20–0.8	0.10	0.25	0.15 <sup>I</sup>	...	...	...	0.05	0.15	rem
2024	0.50	0.50	3.8–4.9	0.30–0.9	1.2–1.8	0.10	0.25	0.15 <sup>I</sup>	...	...	...	0.05	0.15	rem
2219	0.20	0.30	5.8–6.8	0.20–0.40	0.02	...	0.10	0.02–0.10	...	...	...	0.05 <sup>J</sup>	0.15 <sup>J</sup>	rem
3003	0.6	0.7	0.05–0.20	1.0–1.5	...	...	0.10	...	...	...	...	0.05	0.15	rem
Alclad 3003 <sup>K</sup>	...	...	...	...	...	...	...	...	...	...	...	...	...	...
5052	0.25	0.40	0.10	0.10	2.2–2.8	0.15–0.35	0.10	...	...	...	...	0.05	0.15	rem
5083	0.40	0.40	0.10	0.40–1.0	4.0–4.9	0.05–0.25	0.25	0.15	...	...	...	0.05	0.15	rem
5086	0.40	0.50	0.10	0.20–0.7	3.5–4.5	0.05–0.25	0.25	0.15	...	...	...	0.05	0.15	rem
5454	0.25	0.40	0.10	0.50–1.0	2.4–3.0	0.05–0.20	0.25	0.20	...	...	...	0.05	0.15	rem
5456	0.25	0.40	0.10	0.50–1.0	4.7–5.5	0.05–0.20	0.25	0.20	...	...	...	0.05	0.15	rem
6005	0.6–0.9	0.35	0.10	0.10	0.40–0.6	0.10	0.10	0.10	...	...	...	0.05	0.15	rem
6005A	0.50–0.9	0.35	0.30	0.50	0.40–0.7	0.30	0.20	0.10	...	...	...	0.05 <sup>L</sup>	0.15	rem
6013	0.6–1.0	0.50	0.6–1.1	0.20–0.8	0.8–1.2	0.10	0.25	0.10	...	...	...	0.05	0.15	rem
6026	0.6–1.4	0.7	0.20–0.50	0.20–1.0	0.6–1.2	0.30	0.30	0.20	0.50–1.5	0.40	0.05	0.05	0.15	rem
6041	0.50–0.9	0.15–0.7	0.15–0.6	0.05–0.20	0.8–1.2	0.05–0.15	0.25	0.15	0.30–0.9	...	0.35–1.2	0.05	0.15	rem
6042	0.5–1.2	0.7	0.20–0.6	0.40	0.7–1.2	0.04–0.35	0.25	0.15	0.20–0.8	0.15–0.40	...	0.05	0.15	rem
6061 <sup>M</sup>	0.40–0.8	0.7	0.15–0.40	0.15	0.8–1.2	0.04–0.35	0.25	0.15	...	...	...	0.05	0.15	rem
6063	0.20–0.6	0.35	0.10	0.10	0.45–0.9	0.10	0.10	0.10	...	...	...	0.05	0.15	rem
6064	0.40–0.8	0.7	0.15–0.40	0.15	0.8–1.2	0.05–0.14	0.25	0.15	0.50–0.7	0.20–0.40	...	0.05	0.15	rem
6066	0.9–1.8	0.50	0.7–1.2	0.6–1.1	0.8–1.4	0.40	0.25	0.20	...	...	...	0.05	0.15	rem
6082	0.7–1.3	0.50	0.10	0.40–1.0	0.6–1.2	0.25	0.20	0.10	...	...	...	0.05	0.15	rem
6105	0.6–1.0	0.35	0.10	0.15	0.45–0.8	0.10	0.10	0.10	...	...	...	0.05	0.15	rem
6162	0.40–0.8	0.50	0.20	0.10	0.7–1.1	0.10	0.25	0.10	...	...	...	0.05	0.15	rem
6262	0.40–0.8	0.7	0.15–0.40	0.15	0.8–1.2	0.04–0.14	0.25	0.15	0.40–0.7	0.40–0.7	...	0.05	0.15	rem
6351	0.7–1.3	0.50	0.10	0.40–0.8	0.40–0.8	...	0.20	0.20	...	...	...	0.05	0.15	rem
6070	1.0–1.7	0.50	0.15–0.40	0.40–1.0	0.50–1.2	0.10	0.25	0.15	...	...	...	0.05	0.15	rem
7072 <sup>N</sup>	0.7 Si + Fe		0.10	0.10	0.10	...	0.8–1.3	...	...	...	...	0.05	0.15	rem
7075	0.40	0.50	1.2–2.0	0.30	2.1–2.9	0.18–0.28	5.1–6.1	0.20 <sup>O</sup>	...	...	...	0.05	0.15	rem

<sup>A</sup> Limits are in weight [mass] percent maximum unless shown as a range or stated otherwise.

<sup>B</sup> Analysis shall be made for the elements for which limits are shown in this table.

<sup>C</sup> For purposes of determining conformance to these limits, an observed value or a calculated value obtained from analysis shall be rounded to the nearest unit in the last right-hand place of figures used in expressing the specified limit, in accordance with the rounding-off method of Practice E29.

<sup>D</sup> In case there is a discrepancy in the values listed in Table 4 with those listed in the International Alloy Designations and Composition Limits for Wrought Aluminum and Wrought Aluminum Alloys (commonly known as the "Teal Sheets"), the composition limits registered with The Aluminum Association and published in the "Teal Sheets" should be considered the controlling composition. The "Teal Sheets" are available at <http://www.aluminum.org/tealsheets>.

<sup>E</sup> *Others* includes listed elements for which no specific limit is shown as well as unlisted metallic elements. The producer may analyze samples for trace elements not specified in the specification. However, such analysis is not required and may not cover all metallic *Others* elements. Should any analysis by the producer or the purchaser establish that an *Others* element exceeds the limit of *Each* or that the aggregate of several *Others* elements exceeds the limit of *Total*, the material shall be considered nonconforming.

<sup>F</sup> *Other Elements*—Total shall be the sum of unspecified metallic elements 0.010 % or more, rounded to the second decimal before determining the sum.

<sup>G</sup> Vanadium 0.05 % maximum.

<sup>H</sup> The aluminum content shall be calculated by subtracting from 100.00 % the sum of all metallic elements present in amounts of 0.010 % or more each, rounded to the second decimal before determining the sum.

<sup>I</sup> A maximum limit of 0.20 % for zirconium + titanium is permitted upon agreement between the purchaser and producer.

<sup>J</sup> Vanadium 0.05–0.15 %; zirconium, 0.10–0.25 %. The total for other elements does not include vanadium and zirconium.

<sup>K</sup> Alloy 3003 clad with alloy 7072.

<sup>L</sup> 0.12–0.50 Mn + Cr.

<sup>M</sup> Beginning in the 1965 issue, the requirements for alloy 6062 were combined with alloy 6061 by revision of the minimum chromium content of 6061 from 0.15 to 0.04. This action cancelled alloy 6062.

<sup>N</sup> Cladding on Alclad 3003.

<sup>O</sup> A maximum limit of 0.25 % for zirconium + titanium is permitted upon agreement between the purchaser and producer.

TABLE 5 Hardness Screening Values for Seamless Extruded Tube, Inch-Pound Units<sup>A</sup>

Alloy and Temper	Specified Wall Thickness, in.	Hardness Number, min <sup>B,C</sup>		
		Webster	Barcol	Rockwell E
6005-T5	0.050 and over	15	76	89
6005A-T61	0.050 and over	15	76	89
6041-T6	0.050 and over	15	80	92
6042-T5, T5511	0.050 and over	15	76	89
6061-T4	0.050 and over	...	64	...
-T6	0.050 through 0.075	15	76	89
	0.076 through 0.499	15	76	89
	0.500 through 1.000	15	76	...
6063-T1	0.050 through 0.500	...	50	...
-T4	0.050 through 0.500	...	60	...
-T5	0.050 through 0.500	...	65	...
-T6	0.050 through 1.000	12	72	75
6064-T6	0.050 and over	15	76	89
6082-T6	0.050 and over	16	80	92
6105-T5	0.050 and over	15	76	89
6262-T6	0.050 and over	15	76	89
6351-T5	0.050 and over	15	76	89
6351-T6	0.050 through 1.000	16	...	...

<sup>A</sup> See 10.3.<sup>B</sup> Alternate minimum hardness values and hardness testing devices may be used provided agreement is reached between the purchaser and supplier or producer.<sup>C</sup> The hardness values shown do not guarantee material will pass the applicable mechanical property requirements but are for informational purposes only. It is the responsibility of the user of this specification to establish the relationship between the hardness values and tensile properties.TABLE 6 Hardness Screening Values for Seamless Extruded Pipe & Tube [SI Units]<sup>A</sup>

Alloy and Temper	Specified Wall Thickness, mm	Hardness Number, Minimum <sup>B,C</sup>		
		Webster	Barcol	Rockwell E
6005-T5	1.25 and over	15	76	89
6005A-T61	1.25 and over	15	76	89
6041-T6	1.25 and over	15	80	92
6042-T5, T5511	1.25 and over	15	76	89
6061-T4	1.25 and over	...	64	...
-T6	1.25 through 1.50	15	76	89
	over 1.50 through 12.5	15	76	89
	over 12.5 through 25.0	15	76	...
6063-T1	1.25 through 12.5	...	50	...
-T4	1.25 through 12.5	...	60	...
-T5	1.25 through 12.5	...	65	...
-T6	1.25 through 25.0	12	72	75
6064-T6	1.25 and over	15	76	89
6082-T6	1.25 and over	16	80	92
6105-T5	1.25 and over	15	76	89
6262-T6	1.25 and over	15	76	89
6351-T5	1.25 through 25.0	15	76	89
6351-T6	1.25 through 25.0	16	...	...

<sup>A</sup> See Section 10.3.<sup>B</sup> Alternative minimum hardness values and hardness testing devices may be used provided agreement is reached between the purchaser and supplier or producer.<sup>C</sup> The hardness values shown do not guarantee material will pass the applicable mechanical property requirements but are for informational purposes only. It is the responsibility of the user of this specification to establish the relationship between the hardness values and tensile properties.

NOTE 6—It may be necessary in the case of 6xxx—naturally aged tempers to allow for the elapse of four days subsequent to heat treatment for the material to attain its expected strength. Material in these tempers that has been tested for mechanical properties prior to an elapse of four days and fails may be retested after four days without prejudice.

## 11. Heat Treatment and Reheat Treatment Capability

11.1 As-received material in the O or F temper in alloys 2014 and 2024 (within the size limits specified in Table 1 [Table 2] and without the imposition of cold work) shall be capable of attaining the properties specified in Table 1 [Table 2] for T42 temper material, upon being properly solution heat-treated and natural aged for not less than four days at room temperature. Alloys 6061 and 6063 may be required to meet the same requirements per 4.2.9, ordering information, when required by the purchase agreement.

11.2 As-received material in the O or F temper in alloys 2014, 2219, and 7075 (within the size limits specified in Table 1 [Table 2] and without the imposition of cold work) shall be capable of attaining the properties specified in Table 1 [Table 2] for T62 tempers, upon being properly solution and precipitation heat-treated. Alloys 6061 and 6063 may be required to meet the same requirements per 4.2.9, ordering information, when required by the purchase agreement.

11.3 Material in alloys and tempers 2014-T4, T4510, T4511, T6, T6510, and T6511 and 2024-T3, T3510, T3511, T81, T8510, and T8511 shall be capable of attaining the properties specified in Table 1 [Table 2] for the T42 temper, upon being properly resolution heat-treated and natural aged for not less than four days at room temperature.

11.4 Material in alloys and tempers 2219-T31, T3510, T3511, T81, T8510, and T8511, 7075-T6, T6510 and T6511 shall be capable of attaining the properties specified in Table 1 [Table 2] for T62 tempers, upon being properly resolution heat-treated and precipitation heat-treated.

11.5 Material in T31, T3510, T3511, T4, T4510, and T4511 tempers shall be capable of attaining the properties specified in Table 1 [Table 2] for the T81, T8510, T8511, T6, T6510, and T6511 tempers, respectively, upon being properly precipitation heat-treated.

**12. Stress-Corrosion Resistance**

12.1 Alloy 7075 extruded tube in the T73-type tempers shall be capable of exhibiting no evidence of stress-corrosion cracking when subjected to the test specified in 12.2.

12.1.1 For lot-acceptance purposes, resistance to stress-corrosion cracking for each lot shall be established by testing the previously selected tension-test samples to the criteria shown in Table 7 [Table 8].

12.1.2 For surveillance purposes, each month the producer shall perform at least one stress-corrosion test in accordance with 12.2 on each of the T73-type tempers for each thickness range 0.750 in. [20.00 mm] and over listed in Table 1 [Table 2] produced that month. Each sample shall be taken from material considered acceptable in accordance with lot-acceptance criteria of Table 7 [Table 8]. A minimum of three adjacent replicate specimens shall be taken from each sample and tested. The producer shall maintain records of all lots so tested and make them available for examination at the producer’s facility.

12.2 The stress-corrosion cracking test shall be performed on extruded tube with wall thickness 0.750 in. [20.00 mm] and over as follows:

12.2.1 The stress-corrosion test shall be made in accordance with Test Method G47.

12.2.2 Specimens shall be stressed in tension in the short transverse direction with respect to the grain flow and held at constant strain. The stress level shall be 75 % of the specified minimum yield strength.

12.2.3 There shall be no visual evidence of stress-corrosion cracking in any specimen, except that the retest provisions of 17.2 shall apply.

**13. Cladding**

13.1 The aluminum alloy coating of clad tube shall comprise the inside surface of the tube, the outside surface of the tube, or both, and its thickness shall be approximately 10 % of the total wall thickness (inside) or 7 % of the total wall thickness (outside) of the tube.

13.2 When the thickness of the coating is to be determined on finished tube, transverse cross sections of at least three tubes from the lot shall be polished for examination with a metal-lurgical microscope. Using a magnification of 100 ×, the coating thickness at four points, 90° apart, in each sample shall be measured and the average of all measurements shall be taken as the thickness. In the case of tube having a diameter larger than can properly be mounted for polishing and examination, the portions of the cross section polished for examination may consist of an arc about ½ in. [13 mm] in length.

Alloy and Cladding	Approximate Thickness of Cladding, % of Specified Wall Thickness
Alclad 3003 (clad inside)	10
Alclad 3003 (clad outside)	7

**TABLE 7 Lot Acceptance Criteria for Resistance to Stress Corrosion, Inch-Pound Units**

Alloy and Temper	Lot Acceptance Criteria			Lot Acceptance Status
	Electrical Conductivity <sup>A</sup> , % IACS	Level of Tensile Properties		
7075-T73, T73510, and T73511	40.0 or greater	per specified requirements		acceptable
	38.0 thru 39.9	per specified requirements and yield strength does not exceed minimum by more than 11.9 ksi		acceptable
	38.0 thru 39.9	per specified requirements but yield strength exceeds minimum 12.0 ksi or more		unacceptable <sup>B</sup>
	less than 38.0	any level		unacceptable <sup>B</sup>

<sup>A</sup> Sampling for electrical conductivity tests shall be the same as for tensile tests as specified in 9.2. Test specimens may be prepared by machining a flat, smooth surface of sufficient width for proper testing. For small sizes of tubes, a cut-out portion may be flattened and the conductivity determined on the surface. milling may be used on flat surface samples. The electrical conductivity shall be determined in accordance with Practice E1004 in the following locations:

Wall Thickness, in.	Location
up thru 0.100	surface of tensile sample
0.101 thru 0.500	subsurface after removal of approximately 10 % of thickness of tensile sample
0.501 thru 1.500	subsurface at approximately center of wall thickness on a plane parallel to the longitudinal center line of the material
over 1.500	subsurface on tensile test sample surface which is closest to the center of the wall thickness and on a plane parallel to the extrusion surface

<sup>B</sup> When material is found to be unacceptable, it shall be reprocessed (additional precipitation heat treatment, or re-solution heat treatment, stress relieving, straightening and precipitation heat treatment, when applicable).

TABLE 8 Lot Acceptance Criteria for Resistance to Stress Corrosion, [SI Units]

Alloy and Temper	Lot Acceptance Criteria			Lot Acceptance Status
	Electrical Conductivity <sup>A</sup> , MS/m	Level of Mechanical Properties		
7075-T73, T73510, and T73511	23.2 or greater	per specified requirements		acceptable
	22.0 thru 23.1	per specified requirements and yield strength does not exceed minimum by more than 82 MPa		acceptable
	38.0 thru 39.9	per specified requirements but yield strength exceeds minimum by 83 MPa or more		unacceptable <sup>B</sup>
	less than 38.0	any level		unacceptable <sup>B</sup>

<sup>A</sup> Sampling for electrical conductivity tests shall be the same as for tensile tests as specified in 0.2. Test specimens may be prepared by matching a flat, smooth surface of sufficient width for proper testing. For small sizes of tubes, a cut-out portion may be flattened and the conductivity determined on the surface; milling may be used on flat surface samples. The electrical conductivity shall be determined in accordance with Practice E1004 in the following locations:

Wall Thickness, mm		Location
Over	Through	surface of tensile sample
...	2.50	
2.50	12.50	subsurface after removal of approximately 10 % of thickness of tensile sample
12.50	40.00	
40.00	...	subsurface at approximately center of wall thickness on a plane parallel to the longitudinal center line of the material
		subsurface on tensile test sample surface which is closest to the center of the wall thickness and on a plane parallel to the extrusion surface

<sup>B</sup> When material is found to be unacceptable, it shall be reprocessed (additional precipitation heat treatment or re-solution heat treatment, stress relieving, straightening, and precipitation heat treatment, when applicable).

## 14. Dimensional Tolerances

14.1 Variations from the specified dimensions for the type of material ordered shall not exceed the permissible variations prescribed in the following tables of ANSI H35.2 [H35.2(M)]:

Table No. (Section)	Title
12.2	Extruded Tube and Pipe Diameter, Round Tube
12.4	Wall Thickness, Round Extruded Tube
12.6	Length-Extruded Tube
12.8	Straightness, Tube in Straight Lengths
12.10	Squareness of Cut Ends
12	Tube and Pipe
12.49	Outside Diameter Tolerance-Extruded Pipe and Extruded and Drawn Pipe
12.50	Wall Thickness Tolerance-Extruded Pipe and Extruded and Drawn Pipe
12.51	Weight Tolerances-Extruded Pipe and Extruded and Drawn Pipe
12.52	Length Tolerance-Extruded Pipe and Extruded and Drawn Pipe
12.55	Diameters, Wall Thicknesses, Weights

14.2 Tolerances for tempers and sizes not included in ANSI H35.2 [H35.2(M)] shall be as agreed upon between producer and purchaser and shall be so specified in the contract or purchase order.

14.3 *Sampling for Inspection*—Examination for dimensional conformance shall be made to ensure conformance to the tolerance specified.

14.4 Nominal sizes and weights of 14, 16, 18, and 20-in. pipe are given in Table 5. Dimensional Tolerances for these sizes shall be agreed upon between the producer and purchaser and shall be specified in the contract or purchase order.

14.5 *Length Tolerance*—Eighty-five percent or more of the ordered quantity shall be the specified length  $\pm 1$  in. [25 mm]. Fifteen percent of the ordered quantity may be a minimum of 90 % of the specified length, unless other agreement is made between the purchaser and producer.

14.6 *Sampling for Inspection*—Examinations for dimensions shall be made to ensure conformance to the tolerance specified.

## 15. General Quality

15.1 Unless otherwise specified, the material shall be supplied in the mill finish and shall be uniform as defined by the requirements of this specification and shall be commercially sound. Dents and surface finish conditions which do not detract from its usefulness for piping systems shall not be causes for rejection. Grinding to remove minor surface defects is permitted if the dimensional tolerances are met. Any requirement not so covered is subject to negotiation between producer and purchaser.

15.2 When so specified in the contract or order, both ends of each length of pipe, or extruded tube except pipe of alloy 3003, temper H112, shall be threaded using American National Standard Taper Pipe Thread B2.1. The variation from standard, when tested with the standard working gauge, shall not exceed  $\pm 1\frac{1}{2}$  turns. Beveled ends shall be agreed upon between the producer and the purchaser. The threaded ends shall be free from burrs and suitably protected against damage in transit.

15.3 Each pipe and tube shall be examined to determine conformance to this specification with respect to general quality and identification marking. On approval of the purchaser however, the producer may use a system of statistical quality control for such examinations. Discoloration that is characteristic of proper solution heat treatment shall not be cause for rejection

15.4 Grooved ends shall be as specified by the purchaser.

15.5 Threaded ends shall be in accordance with ANSI B2.1. The threaded ends shall be free from burrs and suitably protected from damage during in handling Threading of pipe

made from non heat-treatable alloys in a temper softer than H14 is not recommended.

NOTE 7—Many end configurations have been developed such as the V groove, which appear to be superior to the straight bevel under many circumstances. The “modified vee” described in AWS D10.7 is one example.

**16. Internal Quality**

16.1 When specified by the purchaser at the time of placing the contract or order, each tube 0.500 in. or greater [over 12.50 mm] in thickness, in alloys 2024, and 7075 shall be tested ultrasonically in accordance with Practice B594 to the discontinuity acceptance limits of Table 9 [Table 10].

NOTE 8—Many end configurations have been developed such as the V groove, which appear to be superior to the straight bevel under many circumstances. The “modified vee” described in AWS D10.7 is one example.

**17. Source Inspection**

17.1 If the purchaser desires that his representative inspect or witness the inspection and testing of the material prior to shipment, such agreement shall be made by the purchaser and producer as part of the purchase contract.

17.2 When such inspections or witness of inspection and testing is agreed upon, the producer shall afford the purchaser’s representative all reasonable facilities to satisfy him that the material meets the requirements of this specification. Inspection and tests shall be conducted so there is no unnecessary interference with the producer’s operations.

**18. Retest and Rejection**

18.1 If any material fails to conform to all of the applicable requirements of this specification, the inspection lot shall be rejected.

18.2 When there is evidence that a failed specimen was not representative of the inspection lot and when no other sampling plan is provided or approved by the purchaser through the contract or purchase order, at least two additional specimens shall be selected to replace each test specimen that failed. All specimens so selected for retest shall meet the requirements of the specification or the lot shall be subject to rejection.

18.3 Material in which defects are discovered subsequent to inspection may be rejected.

18.4 If material is rejected by the purchaser, the producer or supplier is responsible only for replacement of material to the purchaser. As much as possible of the rejected material shall be returned to the producer or supplier.

**TABLE 9 Ultrasonic Discontinuity Limits<sup>A</sup>, Inch-Pound Units**

Alloy	Wall Thickness, in.	Max Weight per Piece, lb	Max Width: Thickness Ratio	Discontinuity Class <sup>B</sup>
2024	0.500 & over	600	10:1	B
7075	0.500–1.499	600	10:1	B

<sup>A</sup> Discontinuities in excess of those listed in this table shall be allowed, subject to the approval of the procuring activity, if it is established that they will be removed by machining or that they are in noncritical areas.

<sup>B</sup> The discontinuity class limits are defined in Section 11, Discontinuity Class Limits, of Practice B594.

**TABLE 10 Ultrasonic Discontinuity Limits<sup>A</sup>, [SI Units]**

Alloy	Wall Thickness, mm <sup>B</sup>		Max Mass per Piece, kg	Max Width: Thickness Ratio	Discontinuity Class <sup>C</sup>
	Over	Through			
2024	12.50	...	300	10:1	B
7075	12.50	35.00	300	10:1	B
	35.00	...	300	10:1	A

<sup>A</sup> Discontinuities in excess of those listed in this table shall be allowed, subject to the approval of the procuring activity, if it is established that they will be removed by machining or that they are in noncritical areas.

<sup>B</sup> The thickness of any element of a “profile” is deemed to be the smallest dimension of that element and the discontinuity class applicable to that particular thickness applies to that element of the profile.

<sup>C</sup> The discontinuity class limits are defined in Section 11, Discontinuity Class Limits, of Practice B594.

**19. Identification Marking of Product**

19.1 All pipe and tube shall be marked in accordance with Practice B666/B666M, unless otherwise specified, and when specified (4.2.10) the marking legend shall include the word “seamless.”

19.2 The requirements specified in 19.1 are minimum. Marking systems that involve added information, larger characters and greater frequencies are acceptable under this specification.

**20. Packaging and Package Marking**

20.1 The material shall be packaged to provide adequate protection during normal handling and transportation and each package shall contain only one size, alloy, and temper of material unless otherwise agreed upon. The type of packaging and gross weight of containers shall, unless otherwise agreed upon, be at the producer’s discretion, provided that they are such as to ensure acceptance by common or other carriers for safe transportation at the lowest rate to the delivery point.

20.2 Each shipping container shall be marked with the purchase order number, material size, specification number, alloy and temper, gross and net weights, and the producer’s name or trademark.

20.3 When specified in the contract or purchase order, material shall be preserved, packaged, and packed in accordance with the requirements of Practices B660. The applicable levels shall be as specified in the contract or order. Marking for shipment of such material shall be in accordance with Fed. Std. No. 123 for civilian agencies and MIL-STD-129 for military agencies.

**21. Certification**

21.1 The supplier or producer shall, on request, furnish to the purchaser a certificate stating that the material has been sampled, tested, and inspected in accordance with this specification, and has met the requirements.

**22. Keywords**

22.1 aluminum alloy; seamless extruded tube; seamless pipe

## ANNEXES

## (Mandatory Information)

## A1. BASIS FOR INCLUSION OF PROPERTY LIMITS

A1.1 Mechanical property limits are established in accordance with Section 6, Standards Section, of the most current edition of the Aluminum Standards and Data and the latest edition of the Aluminum Association publication “Tempers for Aluminum and Aluminum Alloy Products (Yellow and Tan Sheets)”.

A1.2 Limits are based on a statistical evaluation of the data indicating that at least 99 % of the population obtained from all standard material meets the limit with 95 % confidence. For the products described, mechanical property limits are based on the statistical analyses of at least 100 tests from at least five cast lots of standard production material with no more than ten observations from a given heat treat or inspection lot. Mechanical properties limits for press solution heat treated products have specific additional requirements which are provided in the “Tempers for Aluminum and Aluminum Alloy Products”.

A1.3 Limits denoted as “Tentative” by the Aluminum Association may be included. Requirements for tentative property registrations are defined in the latest edition of the Aluminum Association publication “Tempers for Aluminum and Aluminum Alloy Products.” Tentative property limits are established at levels at which at least 99 % of the data conform at a confidence level of 95 %. Tentative property limits, which are subject to revision, shall be based on a statistical analysis of at least 30 tests from at least three cast lots of standard production material with no more than ten observations from a given heat treat or inspection lot. Where tentative property limits are listed, they shall be shown in italics and footnoted as Tentative in the standard.

A1.4 All tests are performed in accordance with the appropriate ASTM test methods.

## A2. ACCEPTANCE CRITERIA FOR INCLUSION OF NEW ALUMINUM AND ALUMINUM ALLOYS IN THIS SPECIFICATION

A2.1 Prior to acceptance for inclusion in this specification, the composition of wrought or cast aluminum or aluminum alloy shall be registered in accordance with ANSI H35.1/H35.1(M). The Aluminum Association<sup>3</sup> holds the Secretariat of ANSI H35 Committee and administers the criteria and procedures for registration.

A2.2 If it is documented that the Aluminum Association could not or would not register a given composition, an alternative procedure and the criteria for acceptance shall be as follows:

A2.2.1 The designation submitted for inclusion does not utilize the same designation system as described in ANSI H35.1/H35.1(M). A designation not in conflict with other designation systems or a trade name is acceptable.

A2.2.2 The aluminum or aluminum alloy has been offered for sale in commercial quantities within the prior twelve months to at least three identifiable users.

A2.2.3 The complete composition limits are submitted.

A2.2.4 The composition is, in the judgment of the responsible subcommittee, significantly different from that of any other aluminum or aluminum alloy already in the specification.

A2.2.5 For codification purposes, an alloying element is any element intentionally added for any purpose other than grain refinement and for which minimum and maximum limits are specified. Unalloyed aluminum contains a minimum of 99.00 % aluminum.

A2.2.6 Standard limits for alloying elements and impurities are expressed to the following decimal places:

Less than 0.001 %	0.000X
0.001 to but less than 0.01 %	0.00X
0.01 to but less than 0.10 %	
Unalloyed aluminum made by a refining process	0.0XX
Alloys and unalloyed aluminum not made by a refining process	0.0X
0.10 through 0.55 %	0.XX
(It is customary to express limits of 0.30 through 0.55 % as 0.X0 or 0.X5.)	
Over 0.55 %	0.X, X.X, etc.

(except that combined Si + Fe limits for 99.00 % minimum aluminum must be expressed as 0.XX or 1.XX)

A2.2.7 Standard limits for alloying elements and impurities are expressed in the following sequence: Silicon; Iron; Copper; Manganese; Magnesium; Chromium; Nickel; Zinc; Titanium (Note A2.1); Other Elements, Each; Other Elements, Total; Aluminum (Note A2.2).

NOTE A2.1—Additional specified elements having limits are inserted in

alphabetical order of their symbols between zinc and titanium, or are specified in footnotes.

NOTE A2.2—Aluminum is specified as *minimum* for unalloyed aluminum and as a *remainder* for aluminum alloys.

**A3. PART OR IDENTIFYING NUMBERS (PINs) FOR USE BY THE DEPARTMENT OF DEFENSE**

A3.1 Part numbers are essential to maintain the integrity of the Department of Defense cataloging system as multiple National Stock Numbers (NSN) exist for this product.

A3.2 Part numbers shall be formulated by selecting from the options in this specification as follows:

B241 Document Identifier	-XXXX Alloy	-XXXX Temper	-XX Pipe size in 0.25 in. increments	-XX Schedule size	-XX Length in feet
--------------------------	-------------	--------------	--------------------------------------	-------------------	--------------------

A3.3 *Examples of Part Numbers:*  
 B429-6063-T6-03-40-20 indicates a Specification B429/B429M standard structural pipe in 6063 alloy and T6 temper that is ¾-in. pipe size, ANSI schedule 40, with a 20-ft length.  
 B429-3003-H112-04-10-10 indicates a Specification B429/B429M standard structural pipe in 3003 alloy and H112 temper that is 1-in. pipe size, ANSI schedule 10, with a 10-ft length.

**SUMMARY OF CHANGES**

Committee B07 has identified the location of selected changes to this standard since the last issue (B241/B241M – 16) that may impact the use of this standard. (Approved Oct. 1, 2022.)

- (1) Removed (previously numbered) Tables 1 & 2.
- (2) Revised Section 1 to reflect removal of (previously numbered) Tables 1 & 2.
- (3) Replaced Specifications B210 and B210M with Specification B210/B210M in 2.2.
- (4) Removed references to Test Methods E34 and E607 in 2.2, 7.1, and 7.2.2.
- (5) Added references to Test Method E3061 in 2.2, 7.1, and 7.2.2.
- (6) Removed previous subsection 4.2.3.
- (7) Added 4.2.11.
- (8) Revised footnotes C and D of Table 1, and added Footnote G to Table 1.

- (9) Added references to footnotes F and G to all T42/T62 tempers in Table 1 and Table 2.
- (10) Revised elongation to include “or  $5.65\sqrt{A}$ ” in Table 2.
- (11) Revised footnotes C, D, and E of Table 2.
- (12) Added Alloy 6026 to Table 1, Table 2, and Table 4.
- (13) Added 6351-T5 to Table 5 and Table 6.
- (14) Revised Section 8 to include all applicable tempers allowed in Practices B945, B807/B807M, and B918/B918M.
- (15) Revised 10.1.1, 10.1.2, 10.3, and 10.3.1.
- (16) Revised 11.1 and 11.2.
- (17) Combined previous tables 8 and 10 into Table 5.
- (18) Combined previous tables 9 and 11 into Table 6.
- (19) Editorial changes throughout.

ASTM International takes no position respecting the validity of any patent rights asserted in connection with any item mentioned in this standard. Users of this standard are expressly advised that determination of the validity of any such patent rights, and the risk of infringement of such rights, are entirely their own responsibility.

This standard is subject to revision at any time by the responsible technical committee and must be reviewed every five years and if not revised, either reapproved or withdrawn. Your comments are invited either for revision of this standard or for additional standards and should be addressed to ASTM International Headquarters. Your comments will receive careful consideration at a meeting of the responsible technical committee, which you may attend. If you feel that your comments have not received a fair hearing you should make your views known to the ASTM Committee on Standards, at the address shown below.

This standard is copyrighted by ASTM International, 100 Barr Harbor Drive, PO Box C700, West Conshohocken, PA 19428-2959, United States. Individual reprints (single or multiple copies) of this standard may be obtained by contacting ASTM at the above address or at 610-832-9585 (phone), 610-832-9555 (fax), or service@astm.org (e-mail); or through the ASTM website (www.astm.org). Permission rights to photocopy the standard may also be secured from the Copyright Clearance Center, 222 Rosewood Drive, Danvers, MA 01923, Tel: (978) 646-2600; http://www.copyright.com/

# SPECIFICATION FOR ALUMINUM AND ALUMINUM-ALLOY DIE FORGINGS, HAND FORGINGS, AND ROLLED RING FORGINGS



SB-247

(Identical with ASTM Specification B247-09 except that certification, product marking, and a test report have been made mandatory.)

ASMENORMDOC.COM : Click to view the full PDF of ASME BPVC.II.B (ASME BPVC Section II part B) 2025

# SPECIFICATION FOR ALUMINUM AND ALUMINUM-ALLOY DIE FORGINGS, HAND FORGINGS, AND ROLLED RING FORGINGS



SB-247

(Identical with ASTM Specification B 247-09 except that certification, product marking, and a test report have been made mandatory.)

## 1. Scope

**1.1** This specification covers aluminum-alloy (Note 1) die forgings, hand forgings, and rolled ring forgings as shown in Table 2, Table 3 and Table 4 in Section 10 for heat-treatable alloy forgings supplied in the F and O1 tempers. The maximum thicknesses for forgings within the scope of this specification are as indicated in those tables.

NOTE 1 — Throughout this specification use of the term *alloy* in the general sense includes aluminum as well as aluminum alloy.

NOTE 2 — For forging stock supplied as rolled or cold-finished bar or rod see Specification B211. For forging stock supplied as extruded bar or rod see Specification B221.

**1.2** Alloy and temper designations are in accordance with ANSI H35.1/H35.1(M). The equivalent Unified Numbering System alloy designations are those of Table 1 preceded by A9, for example, A91100 for aluminum 1100 in accordance with Practice E527.

**1.3** For acceptance criteria for inclusion of new aluminum and aluminum alloys in this specification, see Annex A2.

**1.4** This specification is the inch-pound companion to Specification B247M; therefore, no SI equivalents are presented in the specification.

## 2. Referenced Documents

**2.1** The following documents of the issue in effect on date of material purchase form a part of this specification to the extent referenced herein:

### 2.2 ASTM Standards:

- B211 Specification for Aluminum and Aluminum-Alloy Bar, Rod, and Wire
- B221 Specification for Aluminum and Aluminum-Alloy Extruded Bars, Rods, Wire, Profiles, and Tubes

B557 Test Methods for Tension Testing Wrought and Cast Aluminum- and Magnesium-Alloy Products

B594 Practice for Ultrasonic Inspection of Aluminum-Alloy Wrought Products for Aerospace Applications

B660 Practices for Packaging/Packing of Aluminum and Magnesium Products

B881 Terminology Relating to Aluminum- and Magnesium-Alloy Products

B918 Practice for Heat Treatment of Wrought Aluminum Alloys

E10 Test Method for Brinell Hardness of Metallic Materials

E29 Practice for Using Significant Digits in Test Data to Determine Conformance with Specifications

E34 Test Methods for Chemical Analysis of Aluminum and Aluminum-Base Alloys

E165 Practice for Liquid Penetrant Examination for General Industry

E527 Practice for Numbering Metals and Alloys in the Unified Numbering System (UNS)

E607 Test Method for Atomic Emission Spectrometric Analysis Aluminum Alloys by the Point to Plane Technique Nitrogen Atmosphere

E716 Practices for Sampling Aluminum and Aluminum Alloys for Spectrochemical Analysis

E1004 Test Method for Determining Electrical Conductivity Using the Electromagnetic (Eddy-Current) Method

E1251 Test Method for Analysis of Aluminum and Aluminum Alloys by Atomic Emission Spectrometry

G47 Test Method for Determining Susceptibility to Stress-Corrosion Cracking of 2XXX and 7XXX Aluminum Alloy Products

### 2.3 ANSI Standard:

H35.1/H35.1(M) Alloy and Temper Designation Systems

TABLE 1  
CHEMICAL COMPOSITION LIMITS<sup>A,B,C</sup>

Alloy	Silicon	Iron	Copper	Manganese	Magnesium	Chromium	Nickel	Zinc	Titanium	Zirconium	Other Elements <sup>D</sup>		Aluminum
											Each	Total <sup>E</sup>	
1100	0.95 Si + Fe		0.05–0.20	0.05	...	...	...	0.10	...	...	0.05	0.15	99.00 min <sup>F</sup>
2014	0.50–1.2	0.7	3.9–5.0	0.40–1.2	0.20–0.8	0.10	...	0.25	0.15 <sup>G</sup>	...	0.05	0.15	remainder
2018	0.9	1.0	3.5–4.5	0.20	0.45–0.9	0.10	1.7–2.3	0.25	...	...	0.05	0.15	remainder
2025	0.50–1.2	1.0	3.9–5.0	0.40–1.2	0.05	0.10	...	0.25	0.15	...	0.05	0.15	remainder
2218	0.9	1.0	3.5–4.5	0.20	1.2–1.8	0.10	1.7–2.3	0.25	...	...	0.05	0.15	remainder
2219	0.20	0.30	5.8–6.8	0.20–0.40	0.02	...	...	0.10	0.02–0.10	0.10–0.25	0.05 <sup>H</sup>	0.15 <sup>H</sup>	remainder
2618	0.10–0.25	0.9–1.3	1.9–2.7	...	1.3–1.8	...	0.9–1.2	0.10	0.04–0.10	...	0.05	0.15	remainder
3003	0.6	0.7	0.05–0.20	1.0–1.5	...	...	...	0.10	...	...	0.05	0.15	remainder
4032	11.0–13.5	1.0	0.50–1.3	...	0.8–1.3	0.10	0.50–1.3	0.25	...	...	0.05	0.15	remainder
5083	0.40	0.40	0.10	0.40–1.0	4.0–4.9	0.05–0.25	...	0.25	0.15	...	0.05	0.15	remainder
6061	0.40–0.8	0.7	0.15–0.40	0.15	0.8–1.2	0.04–0.35	...	0.25	0.15	...	0.05	0.15	remainder
6066	0.9–1.8	0.50	0.7–1.2	0.6–1.1	0.8–1.4	0.40	...	0.25	0.20	...	0.05	0.15	remainder
6151	0.6–1.2	1.0	0.35	0.20	0.45–0.8	0.15–0.35	...	0.25	0.15	...	0.05	0.15	remainder
7049	0.25	0.35	1.2–1.9	0.20	2.0–2.9	0.10–0.22	...	7.2–8.2	0.10	...	0.05	0.15	remainder
7050	0.12	0.15	2.0–2.6	0.10	1.9–2.6	0.04	...	5.7–6.7	0.06	0.08–0.15	0.05	0.15	remainder
7075	0.40	0.50	1.2–2.0	0.30	2.1–2.9	0.18–0.28	...	5.1–6.1	0.20 <sup>I</sup>	...	0.05	0.15	remainder
7076	0.40	0.6	0.30–1.0	0.30–0.8	1.2–2.0	...	...	7.0–8.0	0.20	...	0.05	0.15	remainder
7175	0.15	0.20	1.2–2.0	0.10	2.1–2.9	0.18–0.28	...	5.1–6.1	0.10	...	0.05	0.15	remainder

<sup>A</sup> Limits are in weight percent maximum unless shown as a range or stated otherwise.

<sup>B</sup> Analysis shall be made for the elements for which limits are shown in this table.

<sup>C</sup> For purposes of determining conformance to these limits, an observed value or a calculated value obtained from analysis shall be rounded to the nearest unit in the last right-hand place of figures used in expressing the specified limit, in accordance with the rounding-off method of Practice E 29.

<sup>D</sup> *Others* includes listed elements for which no specific limit is shown as well as unlisted metallic elements. The producer may analyze samples for trace elements not specified in the specification. However, such analysis is not required and may not cover all metallic *Others* elements. Should any analysis by the producer or the purchaser establish that an *Others* element exceeds the limit of *Each* or that the aggregate of several *Others* elements exceeds the limit of *Total*, the material shall be considered nonconforming.

<sup>E</sup> *Other Elements* — Total shall be the sum of unspecified metallic elements 0.010% or more, rounded to the second decimal before determining the sum.

<sup>F</sup> The aluminum content shall be calculated by subtracting from 100.00% the sum of all metallic elements present in amounts of 0.010% or more each, rounded to the second decimal before determining the sum.

<sup>G</sup> Upon agreement between purchaser and producer or supplier, a zirconium-plus-titanium limit of 0.20% maximum is permitted.

<sup>H</sup> Vanadium, 0.05–0.15%. The total for other elements does not include Vanadium.

<sup>I</sup> Upon agreement between purchaser and producer or supplier, a zirconium-plus-titanium limit of 0.25% maximum is permitted.

TABLE 2  
MECHANICAL PROPERTY LIMITS FOR DIE FORGINGS<sup>A,B</sup>

Alloy and Temper	Specified Thickness, in.	Specimen Axis Parallel to Direction of Grain Flow <sup>C</sup>				Specimen Axis Not Parallel to Direction of Grain Flow <sup>C</sup>			
		Tensile Strength <sup>E</sup> , min, ksi	Yield Strength <sup>E</sup> (0.2% Offset), min, ksi	Elongation <sup>E</sup> in 2 in. or 4 × Dia, min,%		Tensile Strength <sup>E</sup> , min, ksi	Yield Strength <sup>E</sup> (0.2% Offset), min, ksi	Elongation <sup>E</sup> in 2 in. or 4 × Dia, min,% Forgings	Brinell Hardness <sup>D</sup> , min
				Forgings	Separate Test Coupon (from stock or forged) <sup>F</sup>				
1100-H112	up through 4.000	11.0	4.0	18	25	...	...	...	20
2014-T4	up through 4.000	55.0	30.0	11	16	...	...	...	100
2014-T6	up through 1.000	65.0	56.0	6	8	64.0	55.0	3	125
	1.001–2.000	65.0	56.0	6	...	64.0	55.0	2	125
	2.001–3.000	65.0	55.0	6	...	63.0	54.0	2	125
	3.001–4.000	63.0	55.0	6	...	63.0	54.0	2	125
2018-T61	up through 4.000	55.0	40.0	7	10	...	...	...	100
2025-T6	up through 4.000	52.0	33.0	11	16	...	...	...	100
2218-T61	up through 4.000	55.0	40.0	7	10	...	...	...	100
2219-T6	up through 4.000	58.0	38.0	8	10	56.0	36.0	4	100
2618-T61	up through 4.000	58.0	45.0	4	6	55.0	42.0	4	115
3003-H112	up through 4.000	14.0	5.0	18	25	...	...	...	25
4032-T6	up through 4.000	52.0	42.0	3	5	...	...	...	115
5083-H111	up through 4.000	42.0	22.0	14	14	39.0	20.0	12	...
5083-H112	up through 4.000	40.0	18.0	16	16	39.0	16.0	14	...
6061-T6	up through 4.000	38.0	35.0	7	10	38.0	35.0	5	80
6066-T6	up through 4.000	50.0	45.0	8	12	...	...	...	100
6151-T6	up through 4.000	44.0	37.0	10	14	44.0	37.0	6	90
7049-T73	up through 1.000	72.0	62.0	7	10	71.0	61.0	3	135
	1.001–2.000	72.0	62.0	7	10	70.0	60.0	3	135
	2.001–3.000	71.0	61.0	7	10	70.0	60.0	3	135
	3.001–4.000	71.0	61.0	7	10	70.0	60.0	2	135
	4.001–5.000	70.0	60.0	7	10	68.0	58.0	2	135
7050-T74 <sup>G</sup>	up through 2.000	72.0	62.0	7	10	68.0	56.0	5	135
	2.001–4.000	71.0	61.0	7	10	67.0	55.0	4	135
	4.001–5.000	70.0	60.0	7	10	66.0	54.0	3	135
	5.001–6.000	70.0	59.0	7	10	66.0	54.0	3	135

ASMENORMDOC.COM Click to view the full PDF of ASME BPVC.II.B (ASME BPVC Section II part B) 2025

TABLE 2  
MECHANICAL PROPERTY LIMITS FOR DIE FORGINGS<sup>A,B</sup> (CONT'D)

Alloy and Temper	Specified Thickness, in.	Specimen Axis Parallel to Direction of Grain Flow <sup>C</sup>				Specimen Axis Not Parallel to Direction of Grain Flow <sup>C</sup>			
		Tensile Strength <sup>E</sup> , min, ksi	Yield Strength <sup>E</sup> (0.2% Offset), min, ksi	Elongation <sup>E</sup> in 2 in. or 4 × Dia, min,%	Separate Test Coupon (from stock or forged) <sup>F</sup>	Tensile Strength <sup>E</sup> , min, ksi	Yield Strength <sup>E</sup> (0.2% Offset), min, ksi	Elongation <sup>E</sup> in 2 in. or 4 × Dia, min,%	Brinell Hardness <sup>D</sup> , min
7075-T6	up through 1.000	75.0	64.0	7	10	71.0	61.0	3	135
	1.001–2.000	74.0	63.0	7	...	71.0	61.0	3	135
	2.001–3.000	74.0	63.0	7	...	70.0	60.0	3	135
	3.001–4.000	73.0	62.0	7	...	70.0	60.0	2	135
7075-T73	up through 3.000	66.0	56.0	7	...	62.0	53.0	3	125
	3.001–4.000	64.0	55.0	7	...	61.0	52.0	2	125
7075-T7352	up through 3.000	66.0	56.0	7	...	62.0	51.0	3	125
	3.001–4.000	64.0	53.0	7	...	61.0	49.0	2	125
7076-T61	up through 4.000	70.0	60.0	10	14	67.0	58.0	3	140
7175-T74 <sup>G</sup>	up through 3.000	76.0	66.0	7	10	71.0	62.0	4	...
7175-T7452 <sup>G</sup>	up through 3.000	73.0	63.0	7	10	68.0	55.0	4	...
7175-T7454 <sup>G</sup>	up through 3.000	75.0	65.0	7	10	70.0	61.0	4	...

<sup>A</sup> To determine conformance to this specification, each value for tensile strength and yield strength shall be rounded to the nearest 0.1 ksi and each value for elongation to the nearest 0.5% (or the nearest 0.1% if measured in accordance with 7.8.4 of Test Methods B557), in accordance with the rounding-off method of Practice E29.

<sup>B</sup> For the basis for establishment of strength property limits, see Annex A1.

<sup>C</sup> These values apply to standard specimens. For the heat-treatable alloys the thicknesses shown are the maximum thickness at time of heat treatment for which the indicated properties apply. Forgings machined prior to heat treatment shall develop the properties applicable to the heat-treated thickness provided the as-forged thickness is not more than twice the heat-treated thickness.

<sup>D</sup> For information only. The hardness is usually measured on the surface of a forging using a 500-kgf load and 10-mm ball.

<sup>E</sup> Tensile property test requirements in any direction are limited to a minimum material dimension of 2.000 in. because of the difficulty to obtain a tension test specimen suitable for routine control testing.

<sup>F</sup> These values apply to standard 1/2-in. diameter test specimens machined from the stock used in making the forgings, or from separately forged coupons representative of the forgings.

<sup>G</sup> Beginning with the 1985 issue the T736, T73652, and T73654 tempers were replaced by the T74, T7452, and T7454 tempers respectively as applicable to alloys 7050 and 7175.

TABLE 3  
MECHANICAL PROPERTY LIMITS FOR ROLLED RING FORGINGS<sup>A,B,C</sup>

Alloy and Temper	Maximum Heat Treat Section Thickness, in.	Direction	Tensile Strength, Min., ksi <sup>D</sup>	Yield Strength (0.2% Offset), Min., ksi <sup>D</sup>	Elongation in 2 in. or 4 × Diameter, Min., %
2014-T6 and 2014-T652 <sup>E</sup>	up through 2.500	tangential	65.0	55.0	7
		axial	62.0	55.0	3
		radial <sup>F</sup>	60.0	52.0	2
	2.501 to 3.000	tangential	65.0	55.0	6
		axial	62.0	52.0	2
		radial <sup>F</sup>	...	...	...
2219-T6	up through 2.500	tangential	56.0	40.0	6
		axial	55.0	37.0	4
		radial <sup>F</sup>	53.0	35.0	2
2618-T61	up through 2.500	tangential	55.0	41.0	6
		axial	55.0	41.0	5
		radial <sup>F</sup>	...	...	...
6061-T6 and 6061-T652 <sup>E</sup>	up through 2.500	tangential	38.0	35.0	10
		axial	38.0	35.0	8
		radial <sup>F</sup>	37.0	33.0	5
	2.501 to 3.500	tangential	38.0	35.0	8
		axial	38.0	35.0	6
		radial <sup>F</sup>	37.0	33.0	4
6151-T6 and 6151-T652 <sup>E</sup>	up through 2.500	tangential	44.0	37.0	5
		axial	44.0	35.0	4
		radial <sup>F</sup>	42.0	35.0	2
7075-T6 and 7075-T652 <sup>E</sup>	up through 2.000	tangential	73.0	62.0	7
		axial	72.0	61.0	3
		radial <sup>F</sup>	68.0	58.0	2
	2.001 to 3.500	tangential	71.0	60.0	6
		axial	70.0	59.0	3
		radial <sup>F</sup>	...	...	...

<sup>A</sup> To determine conformance to this specification each value for tensile strength and yield strength shall be rounded to the nearest 0.1 ksi and each value for elongation to the nearest 0.5% (or the nearest 0.1% if measured in accordance with 7.8.4 of Test Methods B557), in accordance with the rounding-off method of Practice E29.

<sup>B</sup> Tensile property test requirements in any direction are limited to a minimum material dimension of 2.000 in. because of the difficulty to obtain a tension test specimen suitable for routine control testing.

<sup>C</sup> Applicable only to rings which have an OD-to-wall thickness ratio of 10/1 or greater. Those having a smaller ratio shall be the subject of agreement between the purchaser and producer.

<sup>D</sup> The basis for establishment of mechanical property limits is shown in Annex A1.

<sup>E</sup> Forgings may be available in the T651 temper but shall be the subject of agreement between the purchaser and producer.

<sup>F</sup> Radial properties are not specified requirements. For wall thicknesses 2 in. and greater, they will be determined when specifically requested for informational purposes only.

TABLE 4  
ULTRASONIC DISCONTINUITY LIMITS FOR  
DIE AND HAND FORGINGS<sup>A</sup>

Alloy	Thickness, in.	Product	Maximum Weight per Piece, lb	Discontinuity Class <sup>B</sup>
2014	0.500–4.000	die forgings	300	B
2219	0.500–4.000			
7049	0.500–4.000			
7050	0.500–4.000			
7075	0.500–4.000			
7175	0.500–4.000			
2014	1.000–8.000	hand forgings	600	A
2219	1.000–8.000			
7049	1.000–8.000			
7050	1.000–8.000			
7075	1.000–8.000			
7175	1.000–8.000			

<sup>A</sup> Discontinuities in excess of those listed in this table shall be allowed if it is established that they will be removed by machining or that they are in noncritical areas.

<sup>B</sup> The discontinuity class limits are defined in Section 11 of Practice B594.

#### 2.4 Military Standards:

MIL-STD-129 Marking for Shipment and Storage (referenced in MIL-STD-649 and applies only to direct shipments to Department of Defense agencies).

#### 2.5 SAE:

AMS 2772 Heat Treatment of Aluminum Alloys Raw Materials

#### 2.6 Federal Standard:

Fed. Std. No. 123 Marking for Shipment (Civil Agencies)

#### 2.7 National Aerospace Standard:

NAS 410 Certification and Qualification of Nondestructive Test Personnel

#### 2.8 Other Standards:

CEN EN 14242 Aluminum and aluminum alloys. Chemical Analysis. Inductively coupled plasma optical emission spectral analysis

### 3. Terminology

#### 3.1 Definitions:

**3.1.1** Refer to Terminology B881 for definitions of product terms used in this specification.

#### 3.2 Definitions of Terms Specific to This Standard:

**3.2.1** *capable of* — The term *capable of* as used in this specification means that the test need not be performed by the producer of the material. However, should subsequent testing by the purchaser establish that the material

does not meet the requirements, the material shall be subject to rejection.

### 4. Ordering Information

**4.1** Orders for material to this specification shall include the following information:

**4.1.1** This specification designation (which includes the number, the year, and the revision letter, if applicable),

**4.1.2** Quantity in pieces or pounds,

**4.1.3** Alloy (Section 7),

**4.1.4** Temper (Section 8),

**4.1.5** Dimensions (Section 13). A drawing is required for die forgings and for hand forgings whose shapes are not simple rectangles,

**4.2** Additionally, orders for material to this specification shall include the following information when required by the purchaser:

**4.2.1** For die forgings, whether tensile property and grain flow survey shall be made (8.2.1.1),

**4.2.2** For die forgings, whether tension tests are required using specimens not parallel to the direction of grain flow and whether such test specimens shall be prepared by a specific method (8.3.1),

**4.2.3** For hand forgings, whether tension tests shall be made in other than the long transverse and short transverse directions (8.3.3),

**4.2.4** For rolled ring forgings, whether tension tests shall be made in the radial direction (8.3.4),

**4.2.5** Whether it is required in tension tests that small elongations shall be measured by a special procedure (8.4.2),

**4.2.6** Whether heat treatment in accordance with Practice B918 is required (9.2),

**4.2.7** Whether 7075-F material shall meet the requirements for T73 temper (10.3),

**4.2.8** Whether ultrasonic inspection is required (Section 14 and Table 4),

**4.2.9** Whether liquid-penetrant inspection is required (15.3),

**4.2.10** Whether inspection or witness of inspection and tests by the purchaser's representative is required prior to material shipment (Section 16),

**4.2.11** DELETED

**4.2.12** Whether hand forgings shall be marked for identification (Section 19), and

**4.2.13** Whether Practices B660 applies and, if so, the levels of preservation, packaging, and packing required (Section 20).

## 5. Materials and Manufacture

5.1 The forgings may be manufactured by pressing, hammering, or rolling at the option of the producer.

## 6. Responsibility for Quality Assurance

6.1 *Responsibility for Inspection and Tests* — Unless otherwise specified in the contract or purchase order, the producer is responsible for the performance of all inspection and test requirements specified herein. The producer may use their own or any other suitable facilities for the performance of the inspection and test requirements specified herein, unless disapproved by the purchaser in the order or at the time of contract signing. The purchaser shall have the right to perform any of the inspection and tests set forth in this specification where such inspections are deemed necessary to ensure that material conforms to prescribed requirements.

6.2 *Lot Definition* — An inspection lot shall be defined as follows:

6.2.1 For heat-treated tempers, an inspection lot shall consist of forgings of the same shape, or a group of forgings of similar size and shape, of the same alloy and heat-treated in the same furnace charge. If forgings are heat-treated in a continuous furnace, forgings charged consecutively during continuous operation of the furnace shall be considered a furnace charge; for such forgings weighing 5 lb or less the maximum weight of a lot shall be 2000 lb, and for heavier forgings it shall be 6000 lb.

6.2.2 For nonheat-treated tempers, an inspection lot shall consist of an identifiable quantity of forgings of similar size and shape of the same alloy and temper subjected to inspection at one time.

## 7. Chemical Composition

7.1 *Limits* — The forgings shall conform to the chemical composition limits specified in Table 1. Conformance shall be determined by the producer by analyzing samples taken when the ingots are poured in accordance with E716 and analyzed in accordance with E607, E1251, E34, or EN 14242. If the producer has determined the chemical composition during pouring of the ingots, they shall not be required to sample and analyze the finished product.

7.2 *Sampling during pouring of ingots* — When samples are taken at the time the ingots are poured, at least one sample shall be taken for each group of ingots poured simultaneously from the same source of molten metal.

NOTE 3 — It is standard practice in the United States aluminum industry to determine conformance to the chemical composition limits prior to further processing of ingots into wrought products. Due to the continuous nature of the process, it is not practical to keep a specific ingot analysis identified with a specific quantity of finished material.

7.3 If it becomes necessary to analyze forgings for conformance to chemical composition limits, the method used to sample forgings for the determination of chemical composition shall be by agreement between the producer and the purchaser. Analysis shall be performed in accordance with E716, E607, E1251, E34, or EN 14242 (ICP method). The number of samples taken for determination of chemical composition shall be as follows:

7.3.1 When samples are taken from forgings each weighing 5 lb or less, a sample shall be taken to represent each 2000 lb or fraction thereof of material in the lot.

7.3.2 When samples are taken from forgings each weighing more than 5 lb, a sample shall be taken to represent each 6000 lb or fraction thereof of material in the lot.

7.4 Other methods of analysis or in the case of dispute may be by agreement between the producer and the purchaser.

## 8. Mechanical Properties of Material as Supplied

### 8.1 Limits:

8.1.1 Die forgings shall conform to the tensile requirements in Table 2.

8.1.1.1 Die forgings shall be capable of conforming to the Brinell hardness requirements in Table 2 when measured at or near the surface, except that in case of question the basis for acceptance shall be conformance with the specified minimum tensile requirements of Table 2.

8.1.2 Hand forgings shall conform to the tensile requirements in Table 5.

8.1.3 Rolled ring forgings shall conform to the tensile property requirements in Table 3.

### 8.2 Number of Specimens:

8.2.1 For die forgings, hand forgings, and rolled ring forgings, there shall be at least one tension specimen taken from each lot (see 6.2).

8.2.1.1 For die forgings, when specified, a grain-flow pattern and tensile-property survey shall be made on a forging representative of the first production parts (see 8.3.2). It shall be repeated after any major change in forging technique.

### 8.3 Test Specimen:

8.3.1 For die forgings, unless otherwise specified by the purchaser at the time of placing the order, test specimens shall be prepared with the axis of the specimen as nearly parallel to the direction of maximum metal flow as possible, and, at the option of the forging producer, by one of the following methods:

8.3.1.1 *Method 1* — Machined from a section of the stock used in making the forgings.

TABLE 5  
MECHANICAL PROPERTY LIMITS FOR HAND FORGING<sup>A,B</sup>

Alloy and Temper	Thickness, <sup>C</sup> in.	Direction	Tensile Strength, min, ksi	Yield Strength (0.2% Offset), min, ksi	Elongation in 2 in. or 4 × Diameter, min, %
2014-T6	up through 2.000	longitudinal	65.0	56.0	8
		long transverse	65.0	56.0	3
	2.001–3.000	longitudinal	64.0	56.0	8
		long transverse	64.0	55.0	3
		short transverse	62.0	55.0	2
	3.001–4.000	longitudinal	63.0	55.0	8
		long transverse	63.0	55.0	3
		short transverse	61.0	54.0	2
	4.001–5.000	longitudinal	62.0	54.0	7
		long transverse	62.0	54.0	2
		short transverse	60.0	53.0	1
	5.001–6.000	longitudinal	61.0	53.0	7
		long transverse	61.0	53.0	2
		short transverse	59.0	53.0	1
	6.001–7.000	longitudinal	60.0	52.0	6
		long transverse	60.0	52.0	2
		short transverse	58.0	52.0	1
	7.001–8.000	longitudinal	59.0	51.0	6
		long transverse	59.0	51.0	2
		short transverse	57.0	51.0	1
	2014-T652	up through 2.000	longitudinal	65.0	56.0
long transverse			65.0	56.0	3
2.001–3.000		longitudinal	64.0	56.0	8
		long transverse	64.0	55.0	3
		short transverse	62.0	52.0	2
3.001–4.000		longitudinal	63.0	55.0	8
		long transverse	63.0	55.0	3
		short transverse	61.0	51.0	2
4.001–5.000		longitudinal	62.0	54.0	7
		long transverse	62.0	54.0	2
		short transverse	60.0	50.0	1
5.001–6.000		longitudinal	61.0	53.0	7
		long transverse	61.0	53.0	2
		short transverse	59.0	50.0	1
6.001–7.000		longitudinal	60.0	52.0	6
		long transverse	60.0	52.0	2
		short transverse	58.0	49.0	1
7.001–8.000		longitudinal	59.0	51.0	6
		long transverse	59.0	51.0	2
		short transverse	57.0	48.0	1
2219-T6		up through 4.000	longitudinal	58.0	40.0
	long transverse		55.0	37.0	4
	short transverse <sup>D</sup>		53.0	35.0	2

TABLE 5  
MECHANICAL PROPERTY LIMITS FOR HAND FORGING<sup>A,B</sup> (CONT'D)

Alloy and Temper	Thickness, <sup>C</sup> in.	Direction	Tensile Strength, min, ksi	Yield Strength (0.2% Offset), min, ksi	Elongation in 2 in. or 4 × Diameter, min, %
2219-T852	up through 4.000	longitudinal	62.0	50.0	6
		long transverse	62.0	49.0	4
		short transverse <sup>D</sup>	60.0	46.0	3
2618-T61	up through 2.000	longitudinal	58.0	47.0	7
		long transverse	55.0	42.0	5
		short transverse <sup>D</sup>	52.0	42.0	4
	2.001–3.000	longitudinal	57.0	46.0	7
		long transverse	55.0	42.0	5
		short transverse	52.0	42.0	4
	3.001–4.000	longitudinal	56.0	45.0	7
		long transverse	53.0	40.0	5
		short transverse	51.0	39.0	4
5083-H111	up through 4.000	longitudinal	42.0	22.0	14
		long transverse	39.0	20.0	12
5083-H112	up through 4.000	longitudinal	40.0	18.0	16
		long transverse	39.0	16.0	14
6061-T6 or T652	up through 4.000	longitudinal	38.0	35.0	10
		long transverse	38.0	35.0	8
		short transverse <sup>D</sup>	37.0	33.0	5
	4.001–8.000	longitudinal	37.0	34.0	8
		long transverse	37.0	34.0	6
		short transverse	35.0	32.0	4
7049-T73	2.001–3.000	longitudinal	71.0	61.0	9
		long transverse	71.0	59.0	4
		short transverse	69.0	58.0	3
	3.001–4.000	longitudinal	69.0	59.0	8
		long transverse	69.0	57.0	3
		short transverse	67.0	56.0	2
	4.001–5.000	longitudinal	67.0	56.0	7
		long transverse	67.0	56.0	3
		short transverse	66.0	55.0	2
7049-T7352	1.001–3.000	longitudinal	71.0	59.0	9
		long transverse	71.0	57.0	4
		short transverse <sup>D</sup>	69.0	56.0	3
	3.001–4.000	longitudinal	69.0	57.0	8
		long transverse	69.0	54.0	3
		short transverse	67.0	53.0	2
	4.001–5.000	longitudinal	67.0	54.0	7
		long transverse	67.0	53.0	3
		short transverse	66.0	51.0	2

TABLE 5  
MECHANICAL PROPERTY LIMITS FOR HAND FORGING<sup>A,B</sup> (CONT'D)

Alloy and Temper	Thickness, <sup>C</sup> in.	Direction	Tensile Strength, min, ksi	Yield Strength (0.2% Offset), min, ksi	Elongation in 2 in. or 4 × Diameter, min, %	
7050-T7452 <sup>E</sup>	up through 2.000	longitudinal	72.0	63.0	9	
		long transverse	71.0	61.0	5	
	2.001–3.000	longitudinal	72.0	62.0	9	
		long transverse	70.0	60.0	5	
		short transverse	67.0	55.0	4	
	3.001–4.000	longitudinal	71.0	61.0	9	
		long transverse	70.0	59.0	5	
		short transverse	67.0	55.0	4	
	4.001–5.000	longitudinal	70.0	60.0	9	
		long transverse	69.0	58.0	4	
		short transverse	66.0	54.0	3	
	5.001–6.000	longitudinal	69.0	59.0	9	
		long transverse	68.0	56.0	4	
		short transverse	66.0	53.0	3	
	6.001–7.000	longitudinal	68.0	58.0	9	
		long transverse	67.0	56.0	4	
		short transverse	65.0	52.0	3	
	7.001–8.000	longitudinal	67.0	57.0	9	
		long transverse	66.0	52.0	4	
		short transverse	64.0	50.0	3	
	7075-T6	up through 2.000	longitudinal	74.0	63.0	9
			long transverse	73.0	61.0	4
		2.001–3.000	longitudinal	73.0	61.0	9
			long transverse	71.0	59.0	4
short transverse			69.0	58.0	3	
3.001–4.000		longitudinal	71.0	60.0	8	
		long transverse	70.0	58.0	3	
		short transverse	68.0	57.0	2	
4.001–5.000		longitudinal	69.0	58.0	7	
		long transverse	68.0	56.0	3	
		short transverse	66.0	56.0	2	
5.001–6.000		longitudinal	68.0	56.0	6	
		long transverse	66.0	55.0	3	
		short transverse	65.0	55.0	2	
7075-T652		up through 2.000	longitudinal	74.0	63.0	9
			long transverse	73.0	61.0	4
		2.001–3.000	longitudinal	73.0	61.0	9
			long transverse	71.0	59.0	4
	short transverse		69.0	57.0	2	
	3.001–4.000	longitudinal	71.0	60.0	8	
		long transverse	70.0	58.0	3	
		short transverse	68.0	56.0	1	
	4.001–5.000	longitudinal	69.0	58.0	7	
		long transverse	68.0	56.0	3	
		short transverse	66.0	55.0	1	
	5.001–6.000	longitudinal	68.0	56.0	6	
		long transverse	66.0	55.0	3	
		short transverse	65.0	54.0	1	

TABLE 5  
MECHANICAL PROPERTY LIMITS FOR HAND FORGING<sup>A,B</sup> (CONT'D)

Alloy and Temper	Thickness, <sup>C</sup> in.	Direction	Tensile Strength, min, ksi	Yield Strength (0.2% Offset), min, ksi	Elongation in 2 in. or 4 × Diameter, min, %	
7075-T73	up through 3.000	longitudinal	66.0	56.0	7	
		long transverse	64.0	54.0	4	
		short transverse <sup>D</sup>	61.0	52.0	3	
	3.001–4.000	longitudinal	64.0	55.0	7	
		long transverse	63.0	53.0	3	
		short transverse	60.0	51.0	2	
	4.001–5.000	longitudinal	62.0	53.0	7	
		long transverse	61.0	51.0	3	
		short transverse	58.0	50.0	2	
	5.001–6.000	longitudinal	61.0	51.0	6	
		long transverse	59.0	50.0	3	
		short transverse	57.0	49.0	2	
	7075-T7352	up through 3.000	longitudinal	66.0	54.0	7
			long transverse	64.0	52.0	4
			short transverse <sup>D</sup>	61.0	50.0	3
3.001–4.000		longitudinal	64.0	53.0	7	
		long transverse	63.0	50.0	3	
		short transverse	60.0	48.0	2	
4.001–5.000		longitudinal	62.0	51.0	7	
		long transverse	61.0	48.0	3	
		short transverse	58.0	46.0	2	
5.001–6.000		longitudinal	61.0	49.0	6	
		long transverse	59.0	46.0	3	
		short transverse	57.0	44.0	2	
7175-T74 <sup>E</sup>		up through 3.000	longitudinal	73.0	63.0	9
			long transverse	71.0	60.0	5
			short transverse <sup>D</sup>	69.0	60.0	4
	3.001–4.000	longitudinal	71.0	61.0	9	
		long transverse	70.0	58.0	5	
		short transverse	68.0	57.0	4	
	4.001–5.000	longitudinal	68.0	57.0	8	
		long transverse	67.0	56.0	5	
		short transverse	66.0	55.0	4	
	5.001–6.000	longitudinal	65.0	54.0	8	
		long transverse	64.0	52.0	5	
		short transverse	63.0	52.0	4	

TABLE 5  
MECHANICAL PROPERTY LIMITS FOR HAND FORGING<sup>A,B</sup> (CONT'D)

Alloy and Temper	Thickness, <sup>C</sup> in.	Direction	Tensile Strength, min, ksi	Yield Strength (0.2% Offset), min, ksi	Elongation in 2 in. or 4 × Diameter, min, %
7175-T7452 <sup>E</sup>	up through 3.000	longitudinal	71.0	61.0	9
		long transverse	69.0	58.0	5
		short transverse <sup>D</sup>	67.0	54.0	4
	3.001–4.000	longitudinal	68.0	57.0	9
		long transverse	67.0	55.0	5
		short transverse	65.0	51.0	4
	4.001–5.000	longitudinal	65.0	54.0	8
		long transverse	64.0	52.0	5
		short transverse	63.0	49.0	4
	5.001–6.000	longitudinal	63.0	51.0	8
		long transverse	61.0	49.0	5
		short transverse	60.0	46.0	2

<sup>A</sup> To determine conformance to this specification, each value for tensile strength and yield strength shall be rounded to the nearest 0.1 ksi and each value for elongation to the nearest 0.5% (or the nearest 0.1% if measured in accordance with 7.8.4 of Test Methods B557), in accordance with the rounding-off method of Practice E29.

<sup>B</sup> For the basis for establishment of strength property limits, see Annex A1.

<sup>C</sup> Maximum cross-sectional area is 256 in.<sup>2</sup>, except that for 2618-T61 it is 144 in.<sup>2</sup>. Thickness at heat treatment is measured in the short transverse direction and applies to the dimension as-forged and before any machining operation.

<sup>D</sup> Tensile properties in any direction are limited to a minimum material dimension of 2.000 in. because of the difficulty to obtain a tensile specimen suitable for routine control testing.

<sup>E</sup> Beginning with the 1985 issue the T736 and T73652 tempers were replaced by the T74 and T7452 tempers respectively as applicable to alloys 7050 and 7175.

**8.3.1.2 Method 2** — Machined from a coupon forged from the stock.

**8.3.1.3 Method 3** — Machined from a prolongation of the forging.

**8.3.1.4 Method 4** — Machined from one of the forgings in the lot.

NOTE 4 — Test specimens obtained by Method 1, 2, or 3 will usually have different properties from those obtained by Method 4. Samples obtained by Methods 1, 2, or 3 indicate only the general strength level of the forging that would be obtained with proper heat treatment.

**8.3.1.5** Specimens representing heat-treated forgings shall be heat-treated with the forgings they represent or shall be machined from coupons that have been so treated.

**8.3.2** If required, a die forging representative of the first production parts shall be selected after forging techniques have been established, and shall be tested as follows:

**8.3.2.1** Tension test specimens shall be taken in two directions: (1) substantially parallel to, and (2) not parallel to the forging flow lines. The locations shall be as indicated on the forging engineering drawing or, if not indicated, from generally representative areas.

**8.3.2.2** A sample forging shall be sectioned at the locations of the specimens, to show the grain flow.

**8.3.3** For hand forgings, the specimens shall be taken from a prolongation of the forgings or from a forging chosen to represent the lot. Tests will regularly be made only in the long transverse and short transverse directions, but when required by the purchaser tests shall also be made in the longitudinal direction.

**8.3.4** For rolled ring forgings, the specimens shall be taken from a prolongation of the forging or from a forging chosen to represent the lot. Unless otherwise specified, rolled ring forging sections shall be taken from an area representative of the center of mass where size permits. Tests will regularly be made only in the tangential and axial directions, but when required by the purchaser tests shall also be made in the radial direction for informational purposes.

#### 8.4 Test Methods:

**8.4.1** The tension tests shall be made in accordance with Test Method B557.

**8.4.2** If required when the specified elongation is less than 3% and the elongation measured in the usual manner is less than 4%, the elongation of round tension specimens shall be measured in accordance with 7.8.4 of Test Methods B557.

**8.4.3** Brinell hardness tests shall be made in accordance with Test Method E10, by applying a 500-kgf load

on a 10-mm ball for 10 to 15 s. Other equivalent combinations of load and ball or alternative methods of testing may be used if desired provided that, in case of dispute, the results secured with the 500-kgf load and 10-mm ball shall be the basis of acceptance.

## 9. Heat Treatment

**9.1** Unless otherwise specified in 9.2, heat treatment for the applicable tempers designated in Tables 2 and 3 shall be in accordance with AMS 2772.

**9.2** When specified, heat treatment for the applicable tempers in Tables 2 and 3 shall be in accordance with Practice B918.

## 10. Producer Confirmation of Heat-Treat Response

**10.1** In addition to the requirements of Section 8, die forgings in alloys 2014, 2018, 2025, 2218, 2219, 2618, 4032, 6061, 6066, 6151, 7075, and 7076 produced in the 01 and F tempers (within the size limits specified in Table 2) shall, after proper solution heat treatment and precipitation heat treatment, conform to the tensile properties specified in Table 2 for T6 temper forgings except for 2018, 2218, 2618, and 7076 for which T61 temper requirements apply.

**10.2** In addition to the requirements of Section 8, hand forgings in alloys 2014, 2219, 2618, 6061, and 7075 produced in the 01 and F tempers (within the size limits specified in Table 5) shall, after proper solution heat treatment and precipitation heat treatment, conform to the tensile properties specified in Table 5 for T6 temper forgings except for 2618 for which T61 temper requirements apply.

**10.3** Alloy 7049 die and hand forgings in the F and O tempers and, when specified, 7075 die and hand forgings in the 01 and F tempers (within the size limits specified in Tables 2 and 5, respectively) shall, after proper solution heat treatment and precipitation heat treatment, conform to the tensile properties specified in Tables 2 and 5, as applicable for T73 type temper, and Section 12.

**10.4** Alloys 7050 and 7175 die and hand forgings in the F and O tempers (within the size limits specified in Table 2 and Table 5, respectively) shall, after proper solution heat treatment and precipitation heat treatment, conform to the tensile properties specified in Table 2 and Table 5, as applicable for T74 type temper, and Section 12.

**10.5** In addition to the requirements of Section 8, rolled ring forgings in alloys 2014, 2219, 2618, 6061, 6151, and 7075 produced in F and 01 tempers (within the size limits specified in Table 3) shall, after proper heat treatment, conform to the tensile properties specified in Table 3 for T6 temper forgings except for 2618 for which T61 temper requirements apply.

**10.6 Number of Specimens** — One specimen from each lot of 01 and F temper die forgings, hand forgings, and rolled ring forgings shall be tested to verify conformance with 10.1–10.5, as applicable.

## 11. Heat-Treatment and Reheat-Treatment Capability

**11.1** As-received die and hand forgings in the 01 and F tempers in alloys 2014, 2018, 2025, 2218, 2219, 2618, 4032, 6061, 6066, 6151, 7075, and 7076 (within the size limitations specified in Tables 2 and 5) shall, after proper solution heat treatment and precipitation heat treatment, be capable of conforming to the tensile properties specified in Tables 2 and 5 for the T6 temper except for 2018, 2218, 2618, and 7076 for which T61 temper requirements apply.

**11.2** Alloy 7075 die and hand forgings in T6, T652, T73, and T7352 tempers shall, after proper solution heat treatment and precipitation heat treatment, be capable of conforming to the tensile properties specified in Tables 2 and 5 for the T6 temper.

**11.3** Die forgings in alloy 2014-T4 shall, after proper precipitation heat treatment, be capable of conforming to the tensile properties specified in Table 2 for the T6 temper.

**11.4** As-received rolled ring forgings in the F and 01 tempers in alloys 2014, 2219, 2618, 6061, 6151, and 7075 (within the size limits specified in Table 3) shall, after proper solution heat treatment and precipitation heat treatment, be capable of conforming to the tensile properties specified in Table 3 for the T6 temper except for 2618 for which T61 temper requirements apply.

## 12. Stress-Corrosion Resistance

**12.1** Alloys 7049 and 7075 in the T73-type tempers and alloys 7050 and 7175 in the T74-type tempers shall be capable of exhibiting no evidence of stress-corrosion cracking when subjected to the test specified in 12.2.

**12.1.1** For lot acceptance purposes, resistance to stress-corrosion cracking of each lot of alloys 7049, 7050, 7075, and 7175 in the applicable tempers shall be established by testing the previously selected tension-test samples to the criteria shown in Table 6.

**12.1.2** For surveillance purposes, each month the producer shall perform at least one test for stress-corrosion resistance in accordance with 12.2.2 on each of the applicable alloy-tempers for each thickness range 0.750 in. and over produced that month. Each sample shall be taken from material considered acceptable in accordance with the lot acceptance criteria of Table 6. A minimum of three adjacent replicate specimens shall be taken from each sample and tested. The producer shall maintain records of all lots so

TABLE 6  
 LOT ACCEPTANCE CRITERIA FOR THE CONTROL OF STRESS-CORROSION RESISTANCE FOR ALLOYS 7049 AND  
 7075 IN T73 TYPE TEMPER, AND ALLOYS 7050 AND 7175 IN T74 TYPE TEMPER

Alloy and Temper	Lot Acceptance Criteria		Lot Acceptance Status
	Electrical Conductivity % IACS <sup>A</sup>	Level of Mechanical Properties	
7049-T73 and T7352	40.0 or greater	per specified requirements	acceptable
	38.0 through 39.9	per specified requirements and longitudinal yield strength does not exceed minimum by more than 9.9 ksi	acceptable
	38.0 through 39.9	per specified requirements but longitudinal yield strength exceeds minimum by 10 ksi or more	unacceptable <sup>B</sup>
	less than 38.0	any level	unacceptable <sup>B</sup>
7050-T74 <sup>C</sup> Die forgings and 7050-T7452 <sup>C</sup> Hand forgings	38.0 or greater <sup>D</sup>	per specified requirements and SCF <sup>E</sup> is 32.0 or less	acceptable
	38.0 or greater	per specified requirements but SCF <sup>E</sup> is over 32.0	unacceptable <sup>B</sup>
	less than 38.0	any level	unacceptable <sup>B</sup>
7075-T73 and T7352 and 7175-T74 <sup>C</sup> , T7452 <sup>C</sup> and T7454 <sup>C</sup>	40.0 or greater	per specified requirements	acceptable
	38.0 through 39.9	per specified requirements and longitudinal yield strength does not exceed minimum by more than 11.9 ksi	acceptable
	38.0 through 39.9	per specified requirements but longitudinal yield strength exceeds minimum by 12.0 ksi or more	unacceptable <sup>B</sup>
	less than 38.0	any level	unacceptable <sup>B</sup>

<sup>A</sup> Electrical conductivity measurements shall be made on the surface of the tensile sample in accordance with Test Method E1004.

<sup>B</sup> Alloy 7049 material in tempers T73 and T7352, alloy 7050 material in tempers T74 and T7452, 7075 in tempers T73 and T7352, and 7175 in tempers T74, T7452, and T7454 when unacceptable in accordance with the lot acceptance criteria, shall be subject to reprocessing by additional precipitation heat treatment or re-solution heat treatment and precipitation heat treatment and retested.

<sup>C</sup> Beginning with the 1985 issue the temper designations T736, T73652, and T73654 were replaced by the T74, T7452, and T7454 tempers respectively as applicable to alloys 7050 and 7175.

<sup>D</sup> 7050 Die forgings in the T74 temper also are restricted to having yield strength, parallel to the direction of grain flow, not to exceed 72.0 ksi.

<sup>E</sup> Stress-Corrosion Susceptibility Factor (SCF) equals yield strength (XX.X ksi) — electrical conductivity (XX.X% IACS).

tested and make them available for examination at the producer's facility.

**12.2** The stress-corrosion cracking test shall be performed on material 0.750 in. and over in thickness as follows:

**12.2.1** Specimens shall be stressed in tension in the short transverse direction with respect to grain flow and held at constant strain. The stress level shall be as follows:

**12.2.1.1** For T73-type tempers: 75% of the minimum yield strength or the minimum longitudinal yield strength specified in Table 2 or Table 5 as applicable.

**12.2.1.2** For T74-type tempers: 35.0 ksi for die and hand forgings up through 3.000 in., and 50% of the minimum longitudinal yield strength specified in Table 5 for hand forgings over 3.000 in.

**12.2.2** The stress-corrosion test shall be made in accordance with Test Method G47.

**12.2.3** There shall be no visual evidence of stress-corrosion cracking in any specimen, except that the retest provision of 17.2 shall apply.

### 13. Dimensional Tolerances

**13.1** The forgings shall conform to the shape and dimensions specified in the contract or order within such

dimensional tolerances as may be specified in the contract, order, or referenced drawings.

### 14. Internal Quality

**14.1** When specified by the purchaser at the time of placing the order, each die forging not more than 300 lb, in thicknesses 0.500 to 4.000 in., in alloys 2014, 2219, 7049, 7050, 7075, and 7175, and each hand forging not more than 600 lb, in thicknesses 1.000 to 8.000 in., in alloys 2014, 2219, 7049, 7050, 7075, and 7175 shall be tested ultrasonically in accordance with Practice B594 to the discontinuity acceptance limits of Table 4. For rolled ring forgings ultrasonic testing requirements and the applicable discontinuity acceptance limits in accordance with Practice B594 shall be the subject of agreement between the purchaser and producer.

### 15. General Quality

**15.1** The forgings shall be of uniform quality and condition as defined by the requirements of this specification and shall be commercially sound. Any requirement not so covered shall be subject to agreement between the purchaser and producer.

**15.2 Visual Inspection** — Prior to visual inspection each die forging or rolled ring forging shall be etched in an aqueous solution of sodium hydroxide to provide a surface suitable for visual or penetrant inspection. At the option of the producer, an inhibitor may be used in the sodium hydroxide.

NOTE 5 — An inhibitor in the sodium hydroxide solution is desirable to prevent intergranular attack of copper-bearing alloys. A suitable solution consists of 50 g of sodium hydroxide and 2.5 g of sodium sulphide dissolved in 1 L of water. Etching time for this solution when maintained at 150 to 160°F should be 1 min. Other inhibited solutions may be used to provide the same etching effect. Subsequently, the parts shall be thoroughly rinsed in water followed by a wash in nitric acid or a chromic-sulphuric acid solution or any other equivalent solution to produce a surface suitable for visual or penetrant inspection.

**15.3** Unless otherwise specified, each etched forging shall be inspected visually for surface defects such as seams, laps, bursts, and quench cracks.

**15.3.1** When specified, each etched forging shall be penetrant inspected in accordance with Test Method E165, using post-emulsifiable penetrants or water-washable penetrants, for injurious surface defects. Penetrant inspection personnel shall be certified to NDT Level II in accordance with NAS 410.

NOTE 6 — All parts or areas of parts to be inspected must be clean and dry before the penetrant is applied.

## 16. Source Inspection

**16.1** If the purchaser desires that his representative inspect or witness the inspection and testing of the forgings prior to shipment, such agreement shall be made by the purchaser and producer as part of the purchase contract.

**16.2** When such inspection or witness of inspection and testing is agreed upon the producer shall afford the purchaser's representative all reasonable facilities to satisfy him that the forgings meet the requirements of this specification. Inspection and tests shall be conducted so there is no unnecessary interference with the producer's operations.

## 17. Retest and Rejection

**17.1** If any material fails to conform to all of the applicable requirements of this specification, it shall be cause for rejection of the inspection lot.

**17.2** When there is evidence that a failed specimen was not representative of the inspection lot and when no other sampling plan is provided or approved by the purchaser through the contract or purchase order, at least two additional specimens shall be selected to replace each test specimen that failed. All specimens so selected for retest shall meet the requirements of the specification or the lot shall be subject to rejection.

**17.3** Material in which defects are discovered subsequent to inspection may be rejected.

**17.4** If material is rejected by the purchaser, the producer or supplier is responsible only for replacement of the material to the purchaser. As much as possible of the rejected material shall be returned to the producer or supplier.

## 18. Certification

**18.1** The producer shall furnish to the purchaser a certificate stating that each lot of forgings has been sampled, tested, and inspected in accordance with this specification and has met the requirements. A test report shall be supplied that includes the results of all tests required by the specification.

## 19. Identification Marking of Product

**19.1** Each die forging shall be identification marked in accordance with the requirements of the forging drawing.

**19.2** Hand forgings shall be identification marked with the producer's name or trademark, the applicable alloy and temper designations, and the specification number. Identification characters shall have a minimum height of  $\frac{1}{4}$  in. The marking material shall be such as to resist obliteration during normal handling.

## 20. Packaging and Package Marking

**20.1** The forgings shall be packaged to provide adequate protection during normal handling and transportation and each package shall contain only one size, alloy, and temper of material unless otherwise agreed upon. The type of packaging and gross weight of containers shall, unless otherwise agreed upon, be at the producer's discretion, provided they are such as to ensure acceptance by common or other carriers for safe transportation at the lowest rate to the delivery point.

**20.2** Each shipping container shall be marked with the purchase order number, forging size, specification number, alloy and temper, gross and net weights, and the producer's name or trademark.

**20.3** When specified in the contract or purchase order, material shall be preserved, packaged, and packed in accordance with the requirements of Practices B660. The applicable levels shall be as specified in the contract or order. Marking for shipment of such material shall be in accordance with Fed. Std. No. 123 for civil agencies and MIL-STD-129 for military agencies.

## 21. Keywords

**21.1** aluminum alloy; die forgings; hand forgings; rolled ring forgings

## ANNEXES

## (Mandatory Information)

**A1. BASIS FOR INCLUSION OF PROPERTY LIMITS**

**A1.1** Limits are established at a level at which a statistical evaluation of the data indicates that 99% of the population obtained from all standard material meets the limit with 95% confidence. For the products described, mechanical property limits for the respective size ranges are based on the analyses of at least 100 data from standard production material with no more than ten data from a given lot. All tests are performed in accordance with the appropriate ASTM test methods. For informational purposes, refer to “Statistical Aspects of Mechanical Property Assurance” in the Related Material section of the *Annual Book of ASTM Standards*, Vol 02.02.

**A2. ACCEPTANCE CRITERIA FOR INCLUSION OF NEW ALUMINUM AND ALUMINUM ALLOYS IN THIS SPECIFICATION**

**A2.1** Prior to acceptance for inclusion in this specification, the composition of wrought or cast aluminum or aluminum alloy shall be registered in accordance with ANSI H35.1/H35.1(M). The Aluminum Association Inc. holds the Secretariat of ANSI H35 Committee and administers the criteria and procedures for registration.

**A2.2** If it is documented that The Aluminum Association Inc. could not or would not register a given composition, an alternative procedure and the criteria for acceptance shall be as follows:

**A2.2.1** The designation submitted for inclusion does not utilize the same designation system as described in ANSI H35.1/H35.1(M). A designation not in conflict with other designation systems or a trade name is acceptable.

**A2.2.2** The aluminum or aluminum alloy has been offered for sale in commercial quantities within the prior twelve months to at least three identifiable users.

**A2.2.3** The complete chemical composition limits are submitted.

**A2.2.4** The composition is, in the judgment of the responsible subcommittee, significantly different from that of any other aluminum or aluminum alloy already in the specification.

**A2.2.5** For codification purposes, an alloying element is any element intentionally added for any purpose other than grain refinement and for which minimum and maximum limits are specified. Unalloyed aluminum contains a minimum of 99.00% aluminum.

**A2.2.6** Standard limits for alloying elements and impurities are expressed to the following decimal places:

Less than 0.001%	0.000X
0.001 to but less than 0.01%	0.00X
0.01 to but less than 0.10%	
Unalloyed aluminum made by a refining process	0.0XX
Alloys and unalloyed aluminum not made by a refining process	0.0X
0.10 through 0.55%	0.XX
(It is customary to express limits of 0.30 through 0.55% as 0.X0 or 0.X5.)	
Over 0.55%	0.X, X.X, etc.
(except that combined Si+Fe limits for 99.00% minimum aluminum must be expressed as 0.XX or 1.XX)	

**A2.2.7** Standard limits for alloying elements and impurities are expressed in the following sequence: Silicon; Iron; Copper; Manganese; Magnesium; Chromium; Nickel; Zinc; Titanium (Note A2.1); Other Elements, Each; Other Elements, Total; Aluminum (Note A2.2).

NOTE A2.1 — Additional specified elements having limits are inserted in alphabetical order of their chemical symbols between Titanium and Other Elements, Each, or are specified in footnotes.

NOTE A2.2 — Aluminum is specified as *minimum* for unalloyed aluminum and as a *remainder* for aluminum alloys.

ASMENORMDOC.COM : Click to view the full PDF of ASME BPVC.II.B (ASME BPVC Section II part B) 2025

INTENTIONALLY LEFT BLANK

# SPECIFICATION FOR GENERAL REQUIREMENTS FOR WROUGHT COPPER AND COPPER-ALLOY PLATE, SHEET, STRIP, AND ROLLED BAR



**SB-248**

(Identical with ASTM Specification B248-17 except that certification and a test report have been made mandatory.)

# Specification for General Requirements for Wrought Copper and Copper- Alloy Plate, Sheet, Strip, and Rolled Bar

## 1. Scope

1.1 This specification establishes the general requirements common to several wrought product specifications. Unless otherwise specified in the purchase order or in an individual specification, these general requirements shall apply to copper and copper-alloy plate, sheet, strip, and rolled bar supplied under each of the following product specifications issued by ASTM: B19, B36/B36M, B96/B96M, B103/B103M, B121/B121M, B122/B122M, B130, B152/B152M, B169/B169M, B194, B422/B422M, B465, B534, B591, B592, B694, B740, B747, B768, B888/B888M, and B936.

1.2 *Units*—This specification is the companion specification to SI Specification B248M; therefore, no SI equivalents are shown in this specification.

1.3 *This international standard was developed in accordance with internationally recognized principles on standardization established in the Decision on Principles for the Development of International Standards, Guides and Recommendations issued by the World Trade Organization Technical Barriers to Trade (TBT) Committee.*

## 2. Referenced Documents

2.1 The following documents of the issue in effect on date of material purchase form a part of this specification to the extent referenced herein:

### 2.2 ASTM Standards:

B19 Specification for Cartridge Brass Sheet, Strip, Plate, Bar, and Disks

B36/B36M Specification for Brass Plate, Sheet, Strip, and Rolled Bar

B96/B96M Specification for Copper-Silicon Alloy Plate, Sheet, Strip, and Rolled Bar for General Purposes and Pressure Vessels

B103/B103M Specification for Phosphor Bronze Plate, Sheet, Strip, and Rolled Bar

B121/B121M Specification for Leaded Brass Plate, Sheet, Strip, and Rolled Bar

B122/B122M Specification for Copper-Nickel-Tin Alloy, Copper-Nickel-Zinc Alloy (Nickel Silver), and Copper-Nickel Alloy Plate, Sheet, Strip, and Rolled Bar

B130 Specification for Commercial Bronze Strip for Bullet Jackets

B152/B152M Specification for Copper Sheet, Strip, Plate, and Rolled Bar

B169/B169M Specification for Aluminum Bronze Sheet, Strip, and Rolled Bar

B193 Test Method for Resistivity of Electrical Conductor Materials

B194 Specification for Copper-Beryllium Alloy Plate, Sheet, Strip, and Rolled Bar

B248M Specification for General Requirements for Wrought Copper and Copper-Alloy Plate, Sheet, Strip, and Rolled Bar (Metric)

B422/B422M Specification for Copper-Aluminum-Silicon-Cobalt Alloy, Copper-Nickel-Silicon-Magnesium Alloy, Copper-Nickel-Silicon Alloy, Copper-Nickel-Aluminum-Magnesium Alloy, and Copper-Nickel-Tin Alloy Sheet and Strip

B465 Specification for Copper-Iron Alloy Plate, Sheet, Strip, and Rolled Bar

B534 Specification for Copper-Cobalt-Beryllium Alloy and Copper-Nickel-Beryllium Alloy Plate, Sheet, Strip, and Rolled Bar

B591 Specification for Copper-Zinc-Tin and Copper-Zinc-Tin-Iron-Nickel Alloys Plate, Sheet, Strip, and Rolled Bar

B592 Specification for Copper-Zinc-Aluminum-Cobalt Alloy, Copper-Zinc-Tin-Iron Alloy Plate, Sheet, Strip, and Rolled Bar

B694 Specification for Copper, Copper-Alloy, Copper-Clad Bronze (CCB), Copper-Clad Stainless Steel (CCS), and Copper-Clad Alloy Steel (CAS) Sheet and Strip for Electrical Cable Shielding

B740 Specification for Copper-Nickel-Tin Spinodal Alloy Strip

B747 Specification for Copper-Zirconium Alloy Sheet and Strip

B768 Specification for Copper-Cobalt-Beryllium Alloy and Copper-Nickel-Beryllium Alloy Strip and Sheet

B846 Terminology for Copper and Copper Alloys

B888/B888M Specification for Copper Alloy Strip for Use in Manufacture of Electrical Connectors or Spring Contacts

B936 Specification for Copper-Chromium-Iron-Titanium Alloy Plate, Sheet, Strip and Rolled Bar

E8/E8M Test Methods for Tension Testing of Metallic Materials

E18 Test Methods for Rockwell Hardness of Metallic Materials

E29 Practice for Using Significant Digits in Test Data to Determine Conformance with Specifications

E50 Practices for Apparatus, Reagents, and Safety Considerations for Chemical Analysis of Metals, Ores, and Related Materials

E53 Test Method for Determination of Copper in Unalloyed Copper by Gravimetry

E54 Test Methods for Chemical Analysis of Special Brasses and Bronzes (Withdrawn 2002)

E62 Test Methods for Chemical Analysis of Copper and Copper Alloys (Photometric Methods) (Withdrawn 2010)

E75 Test Methods for Chemical Analysis of Copper-Nickel and Copper-Nickel-Zinc Alloys (Withdrawn 2010)

E106 Test Methods for Chemical Analysis of Copper-Beryllium Alloys (Withdrawn 2011)

E112 Test Methods for Determining Average Grain Size

E118 Test Methods for Chemical Analysis of Copper-Chromium Alloys (Withdrawn 2010)

E121 Test Methods for Chemical Analysis of Copper-Tellurium Alloys (Withdrawn 2010)

E255 Practice for Sampling Copper and Copper Alloys for the Determination of Chemical Composition

E478 Test Methods for Chemical Analysis of Copper Alloys

E527 Practice for Numbering Metals and Alloys in the Unified Numbering System (UNS)

### 3. Terminology

3.1 For definitions of terms related to copper and copper alloys, see Terminology B846.

#### 3.2 Definitions of Terms Specific to This Standard:

3.2.1 *lengths, mill, n*—straight lengths, including ends, that can be conveniently manufactured in the mills. Full-length pieces are usually 8, 10, or 12 ft and subject to established length tolerances.

3.2.2 *lengths, stock, n*—straight lengths that are mill cut and stored in advance of orders. They are usually 8, 10, or 12 ft and subject to established length tolerances.

3.2.3 *rolled bar, n*—a rolled flat product over 0.188 in. thick and up to and including 12 in. wide, with sheared, sawed, or machined edges, in straight lengths or coils (rolls).

## 4. Materials and Manufacture

### 4.1 Materials:

4.1.1 The material of manufacture shall be a cast bar, cake, or slab of such purity and soundness as to be suitable for processing into the products to the product specification listed in Section 1.

4.1.2 When specified in the contract or purchase order that heat identification or traceability is required, the purchaser shall specify the details desired.

### 4.2 Manufacture:

4.2.1 The product shall be manufactured by such hot-working, cold-working and annealing processes as to produce a uniform wrought structure in the finished product.

4.2.2 The product shall be hot- or cold-worked to the finished size and subsequently annealed, when required, to meet the temper properties specified.

4.3 *Edges*—The edges shall be slit, sheared, sawed, or rolled edges, as specified. Slit edges shall be furnished unless otherwise specified in the contract or purchase order. See 5.6 for edge descriptions and corresponding tables for tolerances.

## 5. Dimensions, Weights, and Permissible Variations

5.1 *General*—For the purpose of determining conformance with the dimensional requirements prescribed in this specification, any measured value outside the specified limiting values for any dimension may be cause for rejection.

NOTE 1—Blank spaces in the tolerance tables indicate either that the material is not available or that no tolerances have been established.

5.2 *Thickness*—The standard method of specifying thickness shall be in decimal fractions of an inch. For material 0.021 in. and under in thickness, it is recommended that the nominal thicknesses be stated not closer than the nearest half-thousandth. (For example, specify 0.006 or 0.0065 in., but not 0.0063 in.) For material over 0.021 in. in thickness, it is recommended that the nominal thicknesses be stated not closer than the nearest thousandth. (For example, specify 0.128 or 0.129 in., but not 0.1285 in.) A list of preferred thicknesses is shown in Appendix X1. The thickness tolerances shall be those shown in Tables 1-3 for the product specification indicated:

5.2.1 Table 1—Thickness tolerances applicable to Specifications B36/B36M, B103/B103M, B121/B121M, B152/B152M, B465, B591, B592, B747, and B888/B888M.

5.2.2 Table 2—Thickness tolerances applicable to Specifications B96/B96M, B122/B122M, B169/B169M, B194, B422/B422M, B534, B740, and B768.

5.2.3 Table 3—Special thickness tolerances applicable to Copper Alloy UNS No. C72500 when ordered to Specification B122/B122M, and to Specifications B194, B534, B740, and B768 as noted in the table.

**TABLE 1 Thickness Tolerances**  
(Applicable to Specifications B36/B36M, B103/B103M, B121/B121M, B152/B152M, B465, B591, B592, B747, B888/B888M, and B936)

Thickness, in.	Thickness Tolerances, plus and minus, <sup>A</sup> in.								
	Strip					Sheet			
	8 in. and Under in Width	Over 8 to 12 in., incl, in Width	Over 12 to 14 in., incl, in Width	Over 14 to 20 in., incl, in Width	Over 20 to 24 in., incl, in Width	Over 24 to 28 in., incl, in Width	Over 28 to 36 in., incl, in Width	Over 36 to 48 in., incl, in Width	Over 48 to 60 in., incl, in Width
0.004 and under	0.0003	0.0006	0.0006	...	...	...	...	...	...
Over 0.004 to 0.006, incl	0.0004	0.0008	0.0008	0.0013	...	...	...	...	...
Over 0.006 to 0.009, incl	0.0006	0.0010	0.0010	0.0015	...	...	...	...	...
Over 0.009 to 0.013, incl	0.0008	0.0013	0.0013	0.0018	0.0025	0.0025	0.003	0.0035	0.004
Over 0.013 to 0.017, incl	0.0010	0.0015	0.0015	0.002	0.0025	0.0025	0.003	0.0035	0.0045
Over 0.017 to 0.021, incl	0.0013	0.0018	0.0018	0.002	0.003	0.003	0.0035	0.004	0.005
Over 0.021 to 0.026, incl	0.0015	0.002	0.002	0.0025	0.003	0.003	0.0035	0.004	0.005
Over 0.026 to 0.037, incl	0.002	0.002	0.002	0.0025	0.0035	0.0035	0.004	0.005	0.006
Over 0.037 to 0.050, incl	0.002	0.0025	0.0025	0.003	0.004	0.004	0.005	0.006	0.007
Over 0.050 to 0.073, incl	0.0025	0.003	0.003	0.0035	0.005	0.005	0.006	0.007	0.008
Over 0.073 to 0.130, incl	0.003	0.0035	0.0035	0.004	0.006	0.006	0.007	0.008	0.010
Over 0.130 to 0.188, incl	0.0035	0.004	0.004	0.0045	0.007	0.007	0.008	0.010	0.012
			<b>Rolled Bar</b>					<b>Plate</b>	
Over 0.188 to 0.205, incl	0.0035	0.004	0.004	0.0045	0.007	0.007	0.008	0.010	0.012
Over 0.205 to 0.300, incl	0.004	0.0045	0.0045	0.005	0.009	0.009	0.010	0.012	0.014
Over 0.300 to 0.500, incl	0.0045	0.005	0.005	0.006	0.012	0.012	0.013	0.015	0.018
Over 0.500 to 0.750, incl	0.0055	0.007	0.007	0.009	0.015	0.015	0.017	0.019	0.023
Over 0.750 to 1.00, incl	0.007	0.009	0.009	0.011	0.018	0.018	0.021	0.024	0.029
Over 1.00 to 1.50, incl	0.022	0.022	0.022	0.022	0.022	0.022	0.025	0.029	0.036
Over 1.50 to 2.00, incl	0.026	0.026	0.026	0.026	0.026	0.026	0.030	0.036	0.044

<sup>A</sup> When tolerances are specified as all plus or all minus, double the values given.

5.3 *Width*—The width tolerances shall be those shown in Tables 4-6, depending on the type of edge required (see 5.3.1, 5.3.2, and 5.3.3):

5.3.1 Table 4—Width tolerances for slit metal and slit metal with rolled edges.

5.3.2 Table 5—Width tolerances for square-sheared metal.

5.3.3 Table 6—Width tolerances for sawed metal.

5.4 *Length*—The material shall be furnished in coils or straight lengths of plate, sheet, strip, or rolled bar as specified. The length tolerances for straight lengths shall be those shown in Tables 7-10, depending on the method of cutting required (see 5.4.1 – 5.4.4). When ends are permitted, the length and quantity of the ends shall be in accordance with the schedule in Table 8.

5.4.1 Table 7—Length tolerances, for straight lengths.

5.4.2 Table 8—Schedule of minimum length and maximum weight of ends for mill lengths specific lengths with ends, and stock lengths with ends.

5.4.3 Table 9—Length tolerances for square-sheared metal in all widths 120 in. and under.

5.4.4 Table 10—Length tolerances for sawed metal.

5.5 *Straightness*—The straightness tolerances, which are the maximum edgewise curvature (depth of arc) in any 72-in. portion of the total length, shall be those shown in Tables 11-13, depending on the type of edge required.

5.5.1 Table 11—Straightness tolerances for metal as slit, or as slit and straightened, or as slit and edge-rolled, or metal with drawn edges.

5.5.2 Table 12—Straightness tolerances for square-sheared metal.

5.5.3 Table 13—Straightness tolerances for sawed metal.

5.6 *Edges*—When rolled edges are required, they may be produced by either rolling or drawing to one of the following specified edge contours:

5.6.1 *Square Edges (Square Corners)*—Edges shall have commercially squared corners and with a maximum corner radius as prescribed in Table 14.

5.6.2 *Rounded Corners*—Edges shall have rounded corners as shown in Fig. 1 with a radius as prescribed in Table 15.

5.6.3 *Rounded Edges*—Edges shall be rounded as shown in Fig. 2 with a radius as prescribed in Table 16.

5.6.4 *Full-Rounded Edges*—Edges shall be full rounded as shown in Fig. 3 with a radius as prescribed in Table 17.

5.7 *Weight Tolerances for Hot-Rolled Material:*

5.7.1 Table 18—Lot weight tolerances for hot-rolled sheet and plate applicable to Specifications B36/B36M, B96/B96M (Copper Alloy UNS No. C65500), B103/B103M, B122/B122M, B152/B152M, and B591.

5.7.2 The weight of each lot of five or more plates or sheets of the same type and the same specified dimensions when ordered to thickness, shall not vary from the theoretical by more than the amount prescribed in Table 18 for the product specification indicated. The weight of any individual plate or sheet may vary from the nominal by not more than one third in excess of the tolerances prescribed in Table 18 for the product specification indicated. The tolerances for lots of less than five plates or sheets shall be governed by the tolerances for individual plates or sheets.

5.7.3 For the purpose of calculation, the densities of the materials covered by these specifications are listed in Appendix X2.

**TABLE 2 Thickness Tolerances**  
(Applicable to Specifications B96/B96M, B122/B122M, B169/B169M, B194, B422/B422M, B534, B740, and B768)

Thickness, in.	Thickness Tolerances, Plus and Minus, <sup>A</sup> in.								
	Strip					Sheet			
	8 in. and Under in Width	Over 8 to 12 in., incl, in Width	Over 12 to 14 in., incl, in Width	Over 14 to 20 in., incl, in Width	Over 20 to 24 in., incl, in Width	Over 24 to 28 in., incl, in Width	Over 28 to 36 in., incl, in Width	Over 36 to 48 in., incl, in Width	Over 48 to 60 in., incl, in Width
0.004 and under	0.0004	0.0008	0.0008	...	...	...	...	...	...
Over 0.004 to 0.006, incl	0.0006	0.0010	0.0010	0.0015	...	...	...	...	...
Over 0.006 to 0.009, incl	0.0008	0.0013	0.0013	0.002	...	...	...	...	...
Over 0.009 to 0.013, incl	0.0010	0.0015	0.0015	0.0025	...	...	...	...	...
Over 0.013 to 0.017, incl	0.0013	0.002	0.002	0.0025	...	...	...	...	...
Over 0.017 to 0.021, incl	0.0015	0.0025	0.0025	0.003	...	...	...	...	...
Over 0.021 to 0.026, incl	0.002	0.0025	0.0025	0.003	0.004	0.004	0.005	0.006	0.007
Over 0.026 to 0.037, incl	0.0025	0.003	0.003	0.0035	0.005	0.005	0.006	0.007	0.008
Over 0.037 to 0.050, incl	0.003	0.0035	0.0035	0.004	0.006	0.006	0.007	0.008	0.010
Over 0.050 to 0.073, incl	0.0035	0.004	0.004	0.0045	0.007	0.007	0.008	0.010	0.012
Over 0.073 to 0.130, incl	0.004	0.0045	0.0045	0.005	0.008	0.008	0.010	0.012	0.014
Over 0.130 to 0.188, incl	0.0045	0.005	0.005	0.006	0.010	0.010	0.012	0.014	0.016
		Rolled Bar				Plate			
Over 0.188 to 0.205, incl	0.0045	0.005	0.005	0.006	0.010	0.010	0.012	0.014	0.016
Over 0.205 to 0.300, incl	0.005	0.006	0.006	0.007	0.012	0.012	0.014	0.016	0.018
Over 0.300 to 0.500, incl	0.006	0.007	0.007	0.008	0.015	0.015	0.017	0.019	0.023
Over 0.500 to 0.750, incl	0.008	0.010	0.010	0.012	0.019	0.019	0.021	0.024	0.029
Over 0.750 to 1.00, incl	0.010	0.012	0.012	0.015	0.023	0.023	0.026	0.030	0.037
Over 1.00 to 1.50, incl	0.028	0.028	0.028	0.028	0.028	0.028	0.032	0.037	0.045
Over 1.50 to 2.00, incl	0.033	0.033	0.033	0.033	0.033	0.033	0.038	0.045	0.055

<sup>A</sup> When tolerances are specified as all plus or all minus, double the values given.

**TABLE 3 Special Thickness Tolerances**

Thickness, in.	Tolerances Applicable to Copper Alloy UNS No. C72500, Specification B122/B122M Tolerances, Plus and Minus, <sup>A</sup> in., for Strip 8 in. and Under in Width	Tolerances Applicable to Specifications B194, B534, B740, and B768 Tolerances, Plus and Minus, <sup>A</sup> in., for Strip 4 in. and Under in Width
	0.004 and under	0.0002
Over 0.004 to 0.006, incl	0.0003	0.0003
Over 0.006 to 0.009, incl	0.0004	0.0005
Over 0.009 to 0.013, incl	0.0005	0.0006
Over 0.013 to 0.017, incl	0.0007	0.0007
Over 0.017 to 0.021, incl	0.0008	0.0008
Over 0.021 to 0.026, incl	0.0010	0.0010
Over 0.026 to 0.032, incl	0.0013	0.0010
Over 0.032 to 0.050, incl	0.0015	...

<sup>A</sup> If tolerances are specified as all plus or all minus, double the values given.

**TABLE 4 Width Tolerances for Slit Metal and Slit Metal with Rolled Edges**  
(Applicable to all specifications listed in 1.1)

Width, in.	Width Tolerances, <sup>A</sup> Plus and Minus, in.			
	For Thicknesses 0.004 to 0.032 in.	For Thicknesses Over 0.032 to 0.125 in.	For Thicknesses Over 0.125 to 0.188 in.	For Thicknesses Over 0.188 to 0.500 in.
	2 and under	0.005	0.010	0.012
Over 2 to 8, incl	0.008	0.013	0.015	0.015
Over 8 to 24, incl	1/64	1/64	1/64	1/32
Over 24 to 50, incl	1/32	1/32	1/32	3/64

<sup>A</sup> If tolerances are specified as all plus or all minus, double the values given.

**6. Workmanship, Finish, and Appearance**

6.1 The product shall be free of defects, but blemishes of a nature that do not interfere with the intended application are

**TABLE 5 Width Tolerances for Square-Sheared Metal**  
(Applicable to all specifications listed in 1.1)

NOTE 1—All lengths up to 120 in., incl.

Width, in.	Width Tolerances, <sup>A</sup> Plus and Minus, in.		
	1/16 in. and Under in Thickness	Over 1/16 to 1/8 in., incl. in Thickness	Over 1/8 in. in Thickness
20 and under	1/32	3/64	1/16
Over 20 to 36, incl	3/64	3/64	1/16
Over 36 to 120, incl	1/16	1/16	1/16

<sup>A</sup> If tolerances are specified as all plus or all minus, double the values given.

**TABLE 6 Width Tolerances for Sawed Metal**  
(Applicable to all specifications listed in 1.1)

Width, in.	Width Tolerances, <sup>A</sup> Plus and Minus, in.		
	For Lengths Up to 10 ft, incl		For Lengths Over 10 ft.
	For Thicknesses Up to 1 1/2 in., incl	For Thicknesses Over 1 1/2 in.	All Thicknesses
Up to 12, incl	1/32	1/16	1/16
Over 12 to 120, incl	1/16	1/16	1/16

<sup>A</sup> If tolerances are specified as all plus or all minus, double the values given.

**TABLE 7 Length Tolerances for Straight Lengths**  
(Applicable to all specifications listed in 1.1 except B694)

NOTE 1—The following length tolerances are all plus; if all minus tolerances are desired, use the same values; if tolerances are desired plus and minus, halve the values given.

Length ft.	Length Tolerances in.
Specific lengths, mill lengths, multiple lengths, and specific lengths with ends 10 and under	1/4
Over 10 to 20, incl	1/2
Stock lengths and stock lengths with ends	1 <sup>A</sup>

<sup>A</sup> As stock lengths are cut and placed in stock in advance of orders, departure from the tolerance is not practicable.

acceptable. A superficial film of residual light lubricant is normally present and is acceptable unless otherwise specified.

## 7. Sampling

7.1 *Sampling*—The lot size, portion size, and selection of sample pieces shall be as follows:

7.1.1 *Lot Size*—An inspection lot shall be 10 000 lb or less material of the same mill form, alloy, temper, and nominal dimensions, subject to inspection at one time or shall be the product of one cast bar from a single melt charge, whose weight shall not exceed 25 000 lb and that has been continuously processed and subject to inspection at one time.

7.1.2 *Portion Size*—A portion shall be two representative samples taken from the product of one cast bar that has been continually processed to the finished temper and dimensions.

7.1.2.1 *Chemical Analysis*—A sample for chemical analysis shall be taken in accordance with Practice E255 for product in its final form. Unless otherwise required by the purchaser, at the time the order is placed, the manufacturer shall have the option of determining conformance to chemical composition

by analyzing samples taken at the time the castings are poured or samples taken from the semi-finished product if heat identity can be maintained throughout all operations. If the manufacturer determines the chemical composition during manufacture, he shall not be required to sample and analyze the finished product. The minimum weight of the composite sample in accordance with Practice E255 shall be as follows:

ASTM Designation	Weight of Sample, min, g
B36/B36M, B96/B96M, B121/B121M, B122/B122M, B152/B152M, B169/B169M, B194, B422/B422M, B465, B534, B591, B592, B740, B747, B768, B888/B888M, and B936	150

7.1.2.2 *Samples for All Other Tests*—Samples for all other tests shall be taken from the sample portion in 7.1.2 and be of a convenient size to accommodate the test and comply with the requirements of the appropriate ASTM standards and test methods.

## 8. Number of Tests and Retests

### 8.1 Chemical Requirements:

8.1.1 When samples are taken at the time the castings are poured, at least one sample shall be analyzed for each group of castings poured simultaneously from the same source of molten metal.

8.1.2 When samples are taken from the semi-finished or finished product, at least one sample representative of the product of each cast bar from a single melt charge continuously processed with heat identity maintained shall be analyzed.

8.1.3 When samples are taken from the semi-finished or finished product and heat identity has not been maintained, a single sample representative of each 10 000 lb lot, or fraction thereof, shall be analyzed. When the product piece is greater than 10 000 lb, one sample to be representative of the product piece shall be analyzed.

8.2 *Mechanical and Electrical Requirements and Grain Size*—Unless otherwise provided in the product specification, test specimens shall be taken from each of the two of the sample pieces selected in accordance with 7.1.2. The required tests shall be made on each of the specimens. In the case of copper alloy Specifications B194, B534, and B740, one specimen shall be tested without further treatment, and the other specimen shall be tested after precipitation hardening. In the case of the requirements in Table 4, Mill Hardened Tempers, in Specifications B194 and B740, the two specimens need to be tested, because the product is in the precipitation hardened temper as supplied. The reported value shall be the arithmetic average of the readings. In the case of hardness, three readings shall be taken and averaged for each sample.

### 8.3 Retests:

8.3.1 If the chemical analysis of the specimens prepared from samples selected in accordance with 7.1.2 fails to conform to the specified limits, analysis shall be made on a new composite sample prepared from the samples selected in accordance with 7.1.2.

8.3.2 If one of the two tests made to determine any of the mechanical or physical properties fails to meet a specified limit, this test shall be repeated on the remaining sample

**TABLE 8 Schedule of Minimum Length and Maximum Weight of Ends for Mill Lengths, Specific Lengths with Ends, and Stock Lengths with Ends**  
(Applicable to all specifications listed in 1.1 except B694)

Nominal Length, ft	0.050 in. and Under in Thickness		Over 0.050 to 0.125 in., incl, in Thickness		Over 0.125 to 0.250 in., incl, in Thickness	
	Minimum Length of Shortest Piece, ft	Maximum Permissible Weight of Ends, % of Lot Weight	Minimum Length of Shortest Piece, ft	Maximum Permissible Weight of Ends, % of Lot Weight	Minimum Length of Shortest Piece, ft	Maximum Permissible Weight of Ends, % of Lot Weight
6 to 8, incl	4	20	4	25	3	30
8 to 10, incl	6	25	5	30	4	35
10 to 14, incl	7	30	6	35	5	40

**TABLE 9 Length Tolerances for Square-Sheared Metal in All Widths 120 in. and Under**  
(Applicable to all specifications listed in 1.1 except B694)

Length, in.	Length Tolerance, <sup>A</sup> Plus and Minus, in.		
	For Thick-nesses Up to 1/16 in., incl	For Thicknesses Over 1/16 to 1/8 in., incl	For Thick-nesses Over 1/8 in.
20 and under	1/32	3/64	1/16
Over 20 to 36, incl	3/64	3/64	1/16
Over 36 to 120, incl	1/16	1/16	1/16

<sup>A</sup> If tolerances are specified as all plus or all minus, double the values given.

**TABLE 10 Length Tolerances for Sawed Metal**  
(Applicable to all specifications listed in 1.1 except B694)

NOTE 1—The following tolerances are all plus; if all minus tolerances are desired, use the same values; if tolerances are desired plus and minus, halve the values given.

Width, in.	Length Tolerance, in.
Up to 120, incl	1/4

**TABLE 11 Straightness Tolerances for Slit Metal or Slit Metal Either Straightened or Edge-Rolled**  
(Applicable to all specifications listed in 1.1)

Width, in.	Maximum Edgewise Curvature (Depth of Arc) in any 72-in. Portion of the Total Length		
	Straightness Tolerance, in.		
	As Slit Only		As Slit and Either Straightened or Edge Rolled
	Shipped in Rolls	Shipped Flat	Shipped Flat, in Rolls, or on Bucks
Over 1/4 to 3/8, incl	2	1 1/2	1/2
Over 3/8 to 1/2, incl	1 1/2	1	1/2
Over 1/2 to 1, incl	1	3/4	1/2
Over 1 to 2, incl	5/8	5/8	3/8
Over 2 to 4, incl	1/2	1/2	3/8
Over 4	3/8	3/8	3/8

pieces, selected in accordance with 7.1.2, and the results of these tests shall comply with the specified requirements.

8.3.3 If any test specimen shows defective machining or develops flaws, it may be discarded and another specimen substituted.

8.3.4 If the percentage of elongation of any tension test specimen is less than that specified and any part of the fracture is outside the middle two thirds of the gage length or in a punched or scribed mark within the reduced section, a retest shall be allowed.

**TABLE 12 Straightness Tolerances for Square-Sheared Metal**  
(Applicable to all specifications listed in 1.1)  
(Not applicable to metal over 120 in. in length)

Thickness, in.	Maximum Edgewise Curvature (Depth of Arc) in any 72-in. Portion of the Total Length	
	Straightness Tolerances, in.	
	Up to 10 in., incl, in Width	Over 10 in., in Width
1/8 and under	1/16	1/32
Over 1/8 to 3/16, incl	1/8	3/64
Over 3/16	1/8	1/16

**TABLE 13 Straightness Tolerances for Sawed Metal**  
(Applicable to all specifications listed in 1.1)  
(Not applicable to metal over 144 in. in length)

Width, in.	Maximum Edgewise Curvature (Depth of Arc) in any 72-in. Portion of the Total Length	
	Straightness Tolerances, in.	
3 and under	1/16	
Over 3	3/64	

**TABLE 14 Tolerances for Radius of Commercially Square Corners of Rolled or Drawn Edges with Square Corners**  
(Applicable to all specifications listed in 1.1 except B694)

Thickness, in.	Permissible Radius of Corners, max, in.
0.032 to 0.064, incl	0.010
Over 0.064 to 0.188, incl	0.016
Over 0.188 to 1, incl	1/32

8.3.5 If a bend test specimen fails because of conditions of bending more severe than required by the specification, a retest shall be permitted, either on a duplicate specimen or on a remaining portion of the failed specimen.

8.3.6 After removal of defective specimens and correction of test methods, only one retest cycle is permitted. If after the retest the material fails to meet the requirements of this specification, it shall be rejected.

**9. Specimen Preparation**

9.1 *Chemical Analysis*—A composite sample of the semi-finished or finished product shall be prepared in accordance with Practice E255, or as described in 7.1.2.1.

9.2 Specimens shall be prepared in accordance with the method prescribed in 10.3 for all other tests. Full cross-section specimens shall be used whenever possible. Samples shall be

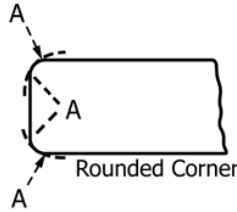

NOTE 1—The arc of the rounded corner shall not necessarily be tangent at points “A,” but the product shall be commercially free from sharp, rough, or projecting edges.

FIG. 1 Rounded Corners

**TABLE 15 Tolerances for Radius on Corners of Rolled or Drawn Edges with Rounded Corners**  
(Applicable to all specifications listed in 1.1 except B694)

Thickness, in.	Radius of Corners, in.	
	Min	Max
Up to 0.125, incl <sup>A</sup>	...	...
Over 0.125 to 0.188, incl	0.016	0.048
Over 0.188 to 1, incl	0.031	0.094
Over 1 to 2, incl	0.063	0.188

<sup>A</sup> Not available.

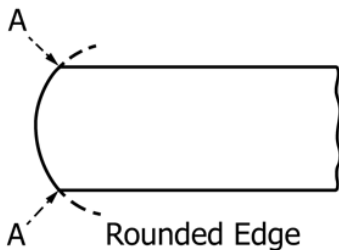

NOTE 1—The arc of the rounded edge shall be substantially symmetrical with the axis of the product. The corners “A” will usually be sharp but shall not have rough or projecting edges.

FIG. 2 Rounded Edge

**TABLE 16 Tolerances for Radius of Rolled or Drawn Rounded Edges**  
(Applicable to all specifications listed in 1.1 except B694)

Thickness, in.	Radius of Edges <sup>A</sup>	
	Min	Max
Up to 0.188, incl	$\frac{3}{4}t$	$1\frac{3}{4}t$
Over 0.188	$1t$	$1\frac{1}{2}t$

<sup>A</sup> The  $t$  refers to the measured thickness of the test specimen.

representative of the condition of the material, and particular specimen preparation techniques shall be stated in the specific product specification.

**10. Test Methods**

10.1 The test method used for routine chemical analysis for specification compliance and preparation of certifications and test reports, when required, shall be at the discretion of the reporting laboratory.

10.1.1 Commonly accepted techniques for routine chemical analysis of copper and copper alloys include, but are not

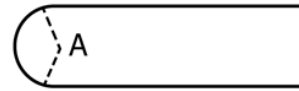

Full Rounded Edge

NOTE 1—The arc of the rounded edge shall not necessarily be tangent at points “A” but shall be substantially symmetrical with the axis of the product, and the product shall be commercially free from sharp, rough, or projecting edges.

FIG. 3 Full Rounded Edge

**TABLE 17 Tolerances for Radius of Rolled or Drawn Full-Rounded Edges**  
(Applicable to all specifications listed in 1.1 except B694)

Thickness, in.	Radius of Edges <sup>A</sup>	
	Min	Max
All thicknesses	$\frac{1}{2}t$	$\frac{3}{4}t$

<sup>A</sup> The  $t$  refers to the thickness of the test specimen.

**TABLE 18 Lot Weight Tolerances for Hot-Rolled Sheet and Plate**  
(Applicable to Specifications B36/B36M, B96/B96M (Copper Alloy UNS Nos. C65500), B103/B103M, B122/B122M, B152/B152M, and B591)

Thickness, in.	Weight Tolerances, Plus and Minus, Percentage of Theoretical Weight				
	48 in. and Under in Width	Over 48 to 60 in., incl. in Width	Over 60 to 72 in., incl. in Width	Over 72 to 90 in., incl. in Width	Over 90 to 110 in., incl. in Width
	$\frac{1}{8}$ and under	8	9.5	11	12.5
Over $\frac{1}{8}$ to $\frac{3}{16}$ , incl	6.5	8	9.5	11	12.5
Over $\frac{3}{16}$ to $\frac{1}{4}$ , incl	6	7.5	8.5	9	10
Over $\frac{1}{4}$ to $\frac{5}{16}$ , incl	5.5	7	8	8.5	9
Over $\frac{5}{16}$ to $\frac{3}{8}$ , incl	5	6	7	7.5	8
Over $\frac{3}{8}$ to $\frac{7}{16}$ , incl	4.5	5	6	7	7.5
Over $\frac{7}{16}$ to $\frac{1}{2}$ , incl	4	4.5	5.5	6	6.5
Over $\frac{1}{2}$ to $\frac{5}{8}$ , incl	3.5	4.5	5	5.5	6
Over $\frac{5}{8}$ to $\frac{3}{4}$ , incl	3	4	4.5	5	5.5
Over $\frac{3}{4}$ to 1, incl	2.75	3.5	4	4.5	5
Over 1 to $1\frac{1}{2}$ , incl	2.5	3	3.5	4	4.5
Over $1\frac{1}{2}$ to 2, incl	2.25	2.75	3.25	3.75	4.25

limited to, X-ray fluorescence spectroscopy, atomic absorption spectrophotometry, argon plasma spectroscopy, and emission spectroscopy.

10.2 In case of disagreement concerning chemical composition, an applicable test method for chemical analysis may be found in Test Methods E53, E54, E62, E75, E106, E118, E121, or E478.

10.2.1 The specific test method(s) to be used will be stated in the particular product specification.

10.2.2 In case of disagreement concerning sulfur content, the test method described in the Annex shall be used.

10.3 The following test methods shall be used for determining the mechanical and physical properties required in the specifications listed in Section 1:

Tension	E8/E8M
Grain size	E112
Rockwell hardness	E18
Electrical resistivity	B193

10.3.1 The testing procedure used for a particular property is dependent upon alloy, temper, and configuration of the product. The manufacturer shall have the option of selecting the most representative procedure unless a specific procedure is specified at the time the contract is placed.

## 11. Significance of Numerical Limits

11.1 For the purposes of determining compliance with the specified limits for requirements of the properties listed in the following table, and for dimensional tolerances, an observed value or a calculated value shall be rounded as indicated in accordance with the rounding method of Practice E29:

Property	Rounded Unit for Observed or Calculated Value
Chemical composition	
Hardness	nearest unit in the last right-hand significant digit used in expressing the limiting value
Electrical resistivity	
Electrical conductivity	
Tensile strength	nearest ksi
Yield strength	nearest ksi
Elongation:	nearest 1 %
Grain size:	
Under 0.060 mm	nearest multiple of 0.005 mm
0.060 mm and over	nearest 0.01 mm

## 12. Inspection

12.1 The manufacturer or supplier shall inspect and make tests necessary to verify that furnished product conforms to specification requirements.

12.2 Source inspection of the product by the purchaser may be agreed upon between the manufacturer or supplier and the purchaser as part of the purchase order. In such case, the nature of the facilities needed to satisfy the inspector, representing the purchaser, that the product is being furnished in accordance with the specification shall be included in the agreement. All testing and the inspection shall be conducted so as not to interfere unnecessarily with the operation of the works.

12.3 When mutually agreed upon, the manufacturer, or supplier, and the purchaser, shall conduct the final inspection simultaneously.

## 13. Rejection and Rehearing

### 13.1 Rejection:

13.1.1 Product that fails to conform to the specification requirements when tested by the purchaser or purchaser's agent shall be subject to rejection.

13.1.2 Rejection shall be reported to the manufacturer or supplier promptly. In addition, a written notification of rejection shall follow.

13.1.3 In case of dissatisfaction with the results of the test, upon which rejection is based, the manufacturer or supplier shall have the option to make claim for a rehearing.

### 13.2 Rehearing:

13.2.1 As a result of product rejection, the manufacturer, or supplier, shall have the option to make claim for a retest to be conducted by the manufacturer, or supplier, and the purchaser. Samples of the rejected product shall be taken in accordance with the product specification and subjected to test by both parties using the test method(s) specified in the product specification, or alternately, upon agreement of both parties, an independent laboratory may be selected for the test(s) using the test method(s) specified in the product specification.

## 14. Certification

14.1 The purchaser shall be furnished certification that samples representing each lot have been either tested or inspected as directed in this specification and that requirements have been met.

### 14.2 DELETED

## 15. Test Report

15.1 A report of test results shall be furnished.

## 16. Product Identification

16.1 For ASME Boiler and Pressure Vessel Code applications, the name or trademark of the manufacturer and the manufacturer's lot identification number shall be legibly stamped or stenciled on each finishing plate and sheet in two places not less than 12 in. from the edge. If the plate and sheet are too small to locate the markings as such, the marking may be placed near the center of the plate and sheet. In the case of butt straps, the markings may be placed 12 in. from the end. The plate number and type shall be legibly stamped on each plate and on each test specimen.

## 17. Packaging and Package Marking

### 17.1 Packaging:

17.1.1 The product shall be separated by size, composition, and temper and prepared for shipment by common carrier, in such a manner as to afford protection from the normal hazards of transportation.

### 17.2 Package Marking:

17.2.1 Each shipping unit shall be legibly marked with the purchase order number, metal or alloy designation, temper, size, shape, gross and net weight, and name of supplier.

17.2.2 When specified in the contract or purchase order, the product specification number shall be shown.

## 18. Keywords

18.1 general requirements, plate; general requirements, rolled bar; general requirements, sheet; general requirements, strip; general requirements, wrought copper and copper alloys

## SUPPLEMENTARY REQUIREMENTS

The following supplementary requirements shall apply only when specified by the purchaser in the inquiry, contract, or order, for agencies of the U.S. Government.

### S1. Referenced Documents

S1.1 The following documents of the issue in effect on date of material purchase form a part of this specification to the extent referenced herein:

S1.1.1 *ASTM Standard:*

B900 Practice for Packaging of Copper and Copper Alloy Mill Products for U.S. Government Agencies

S1.1.2 *Federal Standards:*

Fed. Std. No. 102 Preservation, Packaging and Packing Levels

Fed. Std. No. 123 Marking for Shipment (Civil Agencies)

Fed. Std. No. 185 Identification Marking of Copper and Copper-Base Alloy Mill Products

S1.1.3 *Military Standard:*

MIL-STD-129 Marking for Shipment and Storage

### S2. Quality Assurance

S2.1 *Responsibility for Inspection:*

S2.1.1 Unless otherwise specified in the contract or purchase order, the manufacturer is responsible for the performance of all inspection and test requirements specified. Except as otherwise specified in the contract or purchase order, the manufacturer may use his own or any other suitable facilities for the performance of the inspection and test requirements

unless disapproved by the purchaser at the time the order is placed. The purchaser shall have the right to perform any of the inspections or tests set forth when such inspections and tests are deemed necessary to assure that the material conforms to prescribed requirements.

### S3. Identification Marking

S3.1 All material shall be properly marked for identification in accordance with Fed. Std. No. 185 except that the ASTM specification number and the alloy number shall be used.

### S4. Preparation for Delivery

S4.1 *Preservation, Packaging, Packing:*

S4.1.1 *Military Agencies*—The material shall be separated by size, composition, grade, or class and shall be preserved and packaged, Level A or C, packed, Level A, B, or C, as specified in the contract or purchase order, in accordance with the requirements of Practice B900.

S4.1.2 *Civil Agencies*—The requirements of Fed. Std. No. 102 shall be referenced for definitions of the various levels of packaging protection.

S4.2 *Marking:*

S4.2.1 *Military Agencies*—In addition to any special marking required by the contract or purchase order, marking for shipment shall be in accordance with MIL-STD-129.

S4.2.2 *Civil Agencies*—In addition to any special marking required by the contract or purchase order, marking for shipment shall be in accordance with Fed. Std. No. 123.

## ANNEX

### (Mandatory Information)

#### A1. TEST METHOD FOR SULFUR BY COMBUSTION AND INFRARED DETECTOR

##### A1.1 Scope

A1.1.1 This test method covers the determination of sulfur in electrolytic cathode copper.

A1.1.2 *This standard does not purport to address all of the safety concerns, if any, associated with its use. It is the responsibility of the user of this standard to establish appropriate safety, health, and environmental practices and determine the applicability of regulatory limitations prior to use.*

##### A1.2 Summary of Test Method

A1.2.1 The sulfur is converted to sulfur dioxide (SO<sub>2</sub>) by combustion in a stream of oxygen and the SO<sub>2</sub> is measured by infrared absorption.

A1.2.2 This test method is written for use with commercial analyzers equipped to carry out the above operations automatically.

##### A1.3 Interferences

A1.3.1 The elements ordinarily present do not interfere.

##### A1.4 Apparatus

A1.4.1 *Combustion and Analyzing Instrumentation*, capable of making the required measurements.

##### A1.5 Reagents and Materials

A1.5.1 *Reagents:*

A1.5.1.1 *Accelerator*—Use the accelerator recommended by the instrument manufacturer which, for copper, should be sulfur and tin-free.

A1.5.1.2 *Oxygen*—Ultra high purity, 99.95 % min. Other grades of oxygen may be used if sulfur-free, or the oxygen may be purified as described in Practices E50.

A1.5.2 *Materials:*

A1.5.2.1 *Crucibles*—Use crucibles recommended by the manufacturer, or equivalent.

A1.5.2.2 *Crucible Tongs*—Use tongs capable of handling recommended crucibles.

### A1.6 Hazards

A1.6.1 For precautions to be observed in the use of certain reagents in this test method, refer to Practices E50.

A1.6.2 Use care when handling hot crucibles and operating the furnace to avoid burns and electrical shock.

### A1.7 Preparation of Apparatus

A1.7.1 Assemble and test the apparatus according to the manufacturer's instructions.

### A1.8 Sample Preparation

A1.8.1 The sample should be uniform in size but not finer than 40 mesh.

### A1.9 Calibration

A1.9.1 *Calibration Reference Materials*—Select a minimum of two reference materials with sulfur content near the mid point and high limit.

A1.9.2 *Instrument Calibration*—Calibrate according to the manufacturer's instructions.

### A1.10 Procedure

A1.10.1 Stabilize the furnace and analyzer according to the manufacturer's instruction.

A1.10.2 Transfer the weight of sample recommended by the manufacturer into a crucible and add the same amount of accelerator used in the calibration. Proceed as directed by the manufacturer's instructions.

### A1.11 Calculation

A1.11.1 Since most commercially available instruments calculate percent concentrations directly, including corrections for blank and sample weight, calculations by the analyst are not required.

A1.11.2 If the analyzer does not compensate for blank and sample weight values, use the following equation:

$$\text{Sulfur, \%} = \frac{(A - B) \times C}{D}$$

where:

*A* = Digital voltmeter (DVM) reading for specimen,

*B* = DVM reading for blank,

*C* = weight compensator setting, and

*D* = specimen weight, g.

### A1.12 Precision and Bias

A1.12.1 *Precision*—The precision of this test method is dependent upon sample preparation care and preciseness of calibration.

A1.12.2 *Bias*—The accuracy of this test method is dependent to a large extent upon the accuracy of the methods used to determine the sulfur concentration in the calibration standards as well as their homogeneity.

## APPENDIXES

### (Nonmandatory Information)

#### X1. PREFERRED THICKNESSES FOR UNCOATED WROUGHT COPPER AND COPPER ALLOY PLATE, SHEET, STRIP AND ROLLED BAR, UNDER 0.250 IN.

X1.1 It is recommended that wherever possible material purchased to these specifications be ordered in thicknesses listed as follows:

in.	in.	in.	in.
0.004	0.014	0.040	0.112
0.005	0.016	0.045	0.125
0.006	0.018	0.050	0.140
0.007	0.020	0.056	0.160
0.008	0.022	0.063	0.180
0.009	0.025	0.071	0.200
0.010	0.028	0.080	0.224
0.011	0.032	0.090	
0.012	0.036	0.100	

X2. STANDARD DENSITIES

X2.1 For purposes of calculating weights, cross sections, and so forth, the densities of the copper alloys covered by the specifications listed in the Scope section shall be taken as follows:

ASTM Designation	Material	Copper Alloy UNS No.	Density, lb/in. <sup>3</sup>
B19	copper-zinc alloy	C26000	0.308
B36/B36M	copper-zinc alloy	C21000	0.320
		C22000	0.318
		C22600	0.317
		C23000	0.316
		C24000	0.313
		C26000	0.308
		C26800	0.306
		C27200	0.305
		C28000	0.303
		C65100	0.316
B96/B96M	copper-silicon alloy	C65400	0.309
		C65500	0.308
		C51000	0.320
B103/B103M	copper-tin alloy	C51100	0.320
		C51180	0.320
		C51900	0.319
		C52100	0.318
		C52180	0.318
		C52400	0.317
		C53400	0.322
B121/B121M	copper-tin-iron-nickel alloy copper-tin alloy copper-tin-lead alloy copper-tin-lead-zinc alloy copper-zinc-lead alloy	C54400	0.320
		C33500	0.306
		C34000	0.306
		C34200	0.307
		C35000	0.305
		C35300	0.306
		C35600	0.307
		C70600	0.323
		C70620	0.323
		C71000	0.323
B122/B122M	copper-nickel alloy  copper-nickel-chromium alloy copper-nickel-tin alloy copper-nickel-zinc alloy	C71500	0.323
		C71520	0.323
		C72200	0.323
		C72500	0.321
		C73500	0.319
		C74000	0.314
		C74500	0.313
		C75200	0.316
		C76200	0.310
		C77000	0.314
B130	copper-zinc alloy	C22000	0.318
		C10100, C10200,	0.323
B152/B152M	copper	C10300, C10400,	
		C10500, C10700,	
		C10800, C10910,	
		C12000, C12200	
		C12300, C11000,	0.322
		C11300, C11400,	
		C11600, C14200,	
		C14530	
		C14420	0.321
		C61300	0.285
B169/B169M	copper-aluminum-iron-tin alloy	C61400	0.285
		C17000	0.297
B194	copper-beryllium alloy	C17200	0.297
B422/B422M	copper-nickel-silicon-tin alloy copper-nickel-silicon alloy copper-nickel-silicon-magnesium alloy copper-nickel-silicon-tin alloy copper-nickel-tin alloy copper-aluminum-silicon-cobalt alloy copper-nickel-aluminum-magnesium alloy copper-nickel-silicon-magnesium alloy copper-nickel-silicon alloy copper-nickel-silicon-tin alloy copper-nickel-silicon-silver-zirconium alloy	C19002	0.322
		C19010	0.322
		C19015	0.322
		C19020	0.322
		C19025	0.322
		C63800	0.299
		C64725	0.320
		C70250	0.318
		C70260	0.320
		C70265	0.320
C70310	0.319		

ASTM Designation	Material	Copper Alloy UNS No.	Density, lb/in. <sup>3</sup>
B465	copper-iron alloy	C19200	0.320
		C19210	0.323
		C19400	0.322
		C19500	0.322
		C19700	0.319
B534	copper-cobalt-beryllium alloy copper-nickel-beryllium alloy	C19720	0.319
		C17500	0.316
		C17510	0.317
B591	copper-zinc-tin alloys copper-zinc-tin-nickel alloy	C71700	0.316
		C40500	0.319
	copper-zinc-tin alloys	C40810	0.320
		C40850	0.320
		C40860	0.320
		C41100	0.318
		C41300	0.318
		C41500	0.318
		C42200	0.318
		C42500	0.316
copper-zinc-tin-nickel alloy copper-zinc-tin alloys	C42520	0.318	
	C43000	0.316	
B592	copper-zinc-aluminum-cobalt alloy	C43400	0.316
		C66300	0.317
B694	copper copper-iron alloy copper-zinc alloy	C68800	0.296
		C11000	0.322
		C19400	0.322
B740	copper-zinc-iron-cobalt alloy copper-zinc-iron alloy copper-zinc-iron-tin alloy copper-nickel alloy copper-nickel-tin alloys	C22000	0.318
		C23000	0.316
		C66400	0.318
		C66410	0.318
		C66430	0.317
		C71000	0.323
		C72700	0.321
B747 B768	copper-zirconium alloy copper-cobalt-beryllium alloy copper-nickel-beryllium alloy	C72900	0.323
		C72650	0.320
B888/B888M	copper-tin-tellurium alloy copper-zirconium alloy copper-silver bearing alloy copper-beryllium alloy copper-cobalt-beryllium alloy copper-nickel-beryllium alloy copper-cobalt-beryllium alloy copper-nickel-beryllium alloy copper-nickel-tin alloy copper-nickel-silicon alloy copper-nickel-silicon-magnesium alloy copper-nickel-silicon alloy copper-iron alloy copper-zinc alloy copper-zinc-tin-nickel alloy copper-zinc-tin alloy copper-zinc-tin-iron-nickel alloy copper-tin-iron-nickel alloy copper-tin alloy copper-tin-iron-nickel alloy copper-tin alloy copper-tin-iron-nickel alloy copper-tin alloy copper-tin-iron-nickel alloy copper-aluminum-silicon-cobalt alloy	C15100	0.323
		C14530	0.323
		C15100	0.323
		C15500	0.322
		C17000	0.304
		C17200	0.302
		C17410	0.318
		C17450	0.318
		C17460	0.318
		C17500	0.319
		C17510	0.319
		C19002	0.322
		C19010	0.322
		C19015	0.322
		C19025	0.322
		C19210	0.322
		C19400	0.322
C19500	0.322		
C19700	0.319		
C23000	0.316		
C26000	0.308		
C40810	0.320		
C40850	0.320		
C40860	0.320		
C42200	0.318		
C42500	0.317		
C42520	0.318		
C42600	0.318		
C50580	0.321		
C50780	0.320		
C51000	0.320		
C51080	0.320		
C51100	0.320		
C51180	0.321		
C51980	0.319		
C52100	0.318		
C52180	0.318		
C52480	0.317		
C63800	0.299		

ASTM Designation	Material	Copper Alloy UNS No.	Density, lb/in. <sup>3</sup>
	copper-nickel-zinc-tin-silicon alloy	C64725	0.320
	copper-silicon-tin alloy	C65400	0.309
	copper-zinc-aluminum-cobalt alloy	C68800	0.296
	copper-nickel-silicon-magnesium alloy	C70250	0.318
	copper-nickel-silicon alloy	C70260	0.320
	copper-nickel-silicon-tin alloy	C70265	0.320
	copper-nickel-silicon-silver-zirconium alloy	C70310	0.319
	copper-nickel-zinc alloy	C75200	0.316
		C76200	0.310
B936	copper-chromium-iron-titanium	C18080	0.322

ASME BPVC Section II, part B) 2025

ASME BPVC.II.B (ASME BPVC Section II, part B) 2025

ASMENORMDOC.COM : Click to view the full PDF of ASME BPVC.II.B (ASME BPVC Section II, part B) 2025

# **SPECIFICATION FOR GENERAL REQUIREMENTS FOR WROUGHT COPPER AND COPPER-ALLOY ROD, BAR, SHAPES, AND FORGINGS**



**SB-249/SB-249M**

(Identical with ASTM Specification B249/B249M-20 except that certification and mill test report have been made mandatory.)

ASMENORMDOC.COM : Click to view the full PDF of ASME BPVC.II.B (ASME BPVC Section II part B) 2025

# Specification for General Requirements for Wrought Copper and Copper- Alloy Rod, Bar, Shapes and Forgings

## 1. Scope

1.1 This specification establishes the general requirements common to wrought copper and copper alloy rod, bar, shapes, and forgings which shall apply to Specifications B16/B16M, B21/B21M, B98/B98M, B124/B124M, B138/B138M, B139/B139M, B140/B140M, B150/B150M, B151/B151M, B187/B187M, B196/B196M, B283/B283M, B301/B301M, B371/B371M, B411/B411M, B441, B453/B453M, B455, B570, B870, B927/B927M, B929, B967/B967M, B974/B974M, and B981/B981M to the extent referenced therein.

1.2 The chemical composition, physical and mechanical properties, and all other requirements not included in this specification are prescribed in the product specification.

1.3 *Units*—The values stated in either SI units or inch-pound units are to be regarded separately as standard. The values stated in each system are not necessarily exact equivalents; therefore, to ensure conformance with the standard, each system shall be used independently of the other, and values from the two systems shall not be combined.

1.3.1 Within the text the SI values are given in brackets.

1.4 *This standard does not purport to address all of the safety concerns, if any, associated with its use. It is the responsibility of the user of this standard to establish appropriate safety, health, and environmental practices and determine the applicability of regulatory limitations prior to use.*

1.5 *This international standard was developed in accordance with internationally recognized principles on standardization established in the Decision on Principles for the Development of International Standards, Guides and Recommendations issued by the World Trade Organization Technical Barriers to Trade (TBT) Committee.*

## 2. Referenced Documents

### 2.1 ASTM Standards:

- B16/B16M Specification for Free-Cutting Brass Rod, Bar and Shapes for Use in Screw Machines
- B21/B21M Specification for Naval Brass Rod, Bar, and Shapes
- B98/B98M Specification for Copper-Silicon Alloy Rod, Bar and Shapes
- B124/B124M Specification for Copper and Copper Alloy Forging Rod, Bar, and Shapes
- B138/B138M Specification for Manganese Bronze Rod, Bar, and Shapes
- B139/B139M Specification for Phosphor Bronze Rod, Bar, and Shapes
- B140/B140M Specification for Copper-Zinc-Lead (Red Brass or Hardware Bronze) Rod, Bar, and Shapes
- B150/B150M Specification for Aluminum Bronze Rod, Bar, and Shapes
- B151/B151M Specification for Copper-Nickel-Zinc Alloy (Nickel Silver) and Copper-Nickel Rod and Bar
- B154 Test Method for Mercurous Nitrate Test for Copper Alloys
- B187/B187M Specification for Copper, Bus Bar, Rod, and Shapes and General Purpose Rod, Bar, and Shapes
- B193 Test Method for Resistivity of Electrical Conductor Materials
- B194 Specification for Copper-Beryllium Alloy Plate, Sheet, Strip, and Rolled Bar
- B196/B196M Specification for Copper-Beryllium Alloy Rod and Bar
- B283/B283M Specification for Copper and Copper-Alloy Die Forgings (Hot-Pressed)
- B301/B301M Specification for Free-Cutting Copper Rod, Bar, Wire, and Shapes
- B371/B371M Specification for Copper-Zinc-Silicon Alloy Rod

B411/B411M Specification for Copper-Nickel-Silicon Alloy Rod and Bar

B441 Specification for Copper-Cobalt-Beryllium, Copper-Nickel-Beryllium, and Copper-Nickel-Lead-Beryllium Rod and Bar (UNS Nos. C17500, C17510, and C17465)

B453/B453M Specification for Copper-Zinc-Lead Alloy (Leaded-Brass) Rod, Bar, and Shapes

B455 Specification for Copper-Zinc-Lead Alloy (Leaded-Brass) Extruded Shapes

B570 Specification for Copper-Beryllium Alloy (UNS Nos. C17000 and C17200) Forgings and Extrusions

B577 Test Methods for Detection of Cuprous Oxide (Hydrogen Embrittlement Susceptibility) in Copper

B846 Terminology for Copper and Copper Alloys

B858 Test Method for Ammonia Vapor Test for Determining Susceptibility to Stress Corrosion Cracking in Copper Alloys

B870 Specification for Copper-Beryllium Alloy Forgings and Extrusions Alloys (UNS Nos. C17500 and C17510)

B900 Practice for Packaging of Copper and Copper Alloy Mill Products for U.S. Government Agencies

B927/B927M Specification for Brass Rod, Bar, and Shapes

B929 Specification for Copper-Nickel-Tin Spinodal Alloy Rod and Bar

B967/B967M Specification for Copper-Zinc-Tin-Bismuth Alloy Rod, Bar and Wire

B974/B974M Specification for Free-Cutting Bismuth Brass Rod, Bar and Wire

B981/B981M Specification for Low-Leaded Brass Rod, Bar, Wire, and Shapes

D4855 Practice for Comparing Test Methods (Withdrawn 2008)

E3 Guide for Preparation of Metallographic Specimens

E8/E8M Test Methods for Tension Testing of Metallic Materials

E18 Test Methods for Rockwell Hardness of Metallic Materials

E29 Practice for Using Significant Digits in Test Data to Determine Conformance with Specifications

E53 Test Method for Determination of Copper in Unalloyed Copper by Gravimetry

E54 Test Methods for Chemical Analysis of Special Brasses and Bronzes (Withdrawn 2002)

E62 Test Methods for Chemical Analysis of Copper and Copper Alloys (Photometric Methods) (Withdrawn 2010)

E75 Test Methods for Chemical Analysis of Copper-Nickel and Copper-Nickel-Zinc Alloys (Withdrawn 2010)

E76 Test Methods for Chemical Analysis of Nickel-Copper Alloys (Withdrawn 2003)

E112 Test Methods for Determining Average Grain Size

E118 Test Methods for Chemical Analysis of Copper-Chromium Alloys (Withdrawn 2010)

E121 Test Methods for Chemical Analysis of Copper-Tellurium Alloys (Withdrawn 2010)

E255 Practice for Sampling Copper and Copper Alloys for

the Determination of Chemical Composition

E290 Test Methods for Bend Testing of Material for Ductility

E478 Test Methods for Chemical Analysis of Copper Alloys

E581 Test Methods for Chemical Analysis of Manganese-Copper Alloys

2.2 ASME Standard:

ASME Boiler and Pressure Vessel Code

### 3. Terminology

3.1 For definitions of terms related to copper and copper alloys, refer to Terminology B846.

3.2 *Definitions of Terms Specific to This Standard:*

3.2.1 *lengths, mill, n*—straight lengths, including ends, that can be conveniently manufactured in the mill. Full length pieces are usually 10 ft or 12 ft [3000 mm or 3600 mm].

3.2.2 *lengths, stock, n*—straight lengths that are mill cut and stored in advance of orders. They are usually 10 ft or 12 ft [3000 mm or 3600 mm] and subject to established length tolerances.

### 4. Materials and Manufacture

4.1 *Materials:*

4.1.1 The material of manufacture shall be a form of the Copper or Copper Alloy UNS No. designation specified in the ordering information of such purity and soundness as to be suitable for processing into the products described in the product specification.

4.1.2 When specified in the contract or purchase order that heat identification or traceability is required, the purchaser shall specify the details desired.

NOTE 1—Due to the discontinuous nature of the processing of castings into wrought products, it is not always practical to identify specific casting analysis with a specific quantity of finished product.

4.2 *Manufacture*—The product shall be manufactured by such hot-working, cold-working, and annealing processes as to produce a uniform wrought structure in the finished product.

4.2.1 The product shall be hot- or cold-worked to the finished size and subsequently annealed or heat treated when required, and straightened to meet the properties specified.

4.2.2 *Edges*—The edge shall be drawn, extruded, or rolled; refer to Edge Contours in Section 6.

### 5. Chemical Composition

5.1 The material shall conform to the chemical composition requirements prescribed in the product specification.

5.1.1 Results of analysis on a product (check) sample shall conform to the composition requirements within the permitted analytical variance given in the product specification.

5.2 The composition limits established for the Copper or Copper Alloy UNS No. designation specified in the product specification do not preclude the presence of other elements.

By agreement between the manufacturer or supplier and the purchaser, limits may be established and analysis required for unnamed elements.

5.3 When material composition has been determined during the course of manufacture, analysis of the finished product by the manufacturer is not required.

**6. Dimensions, Mass and Permissible Variations**

6.1 *General*—For the purpose of determining conformance with the dimensional requirements, any measured value outside the specified limiting values for any dimension may be cause for rejection.

6.1.1 The dimensions and tolerances for products referenced to this specification shall be as noted in the following paragraphs and tables, where the product specification is noted in the table heading.

NOTE 2—Blank spaces in the tolerance tables indicate either that the material generally is not available or that no tolerances are established.

6.2 *Diameter or Distance Between Parallel Surfaces*—The diameter of round sections or the distance between parallel surfaces in the case of other sections, except shapes, shall not vary from that specified by more than the amounts specified in Tables 1-12, included, for the product specification indicated.

Table 1 and Table 2—List the tolerances for diameter or distance between parallel surfaces of cold-drawn rod in round, hexagonal, and octagonal cross sections. Applicable product specifications and alloys are shown in the table titles.

Table 3—Lists the diameter tolerances for piston finish rod applicable to product specifications shown in the table title.

Table 4 and Table 5—List the tolerances for diameter or distance between parallel surfaces of as-extruded rod and bar applicable to the specifications and alloys shown in the table titles. These tolerances are applicable to round, hexagonal, and octagonal rod as well as square and rectangular bar.

Table 6—Lists the diameter tolerances for hot-rolled round rod applicable to the product specification shown in the table title.

**TABLE 1 Tolerances for Diameter or Distance Between Parallel Surfaces of Cold-Drawn Rod**

(Applicable to Specifications B16/B16M, B21/B21M, B98/B98M (Copper Alloy UNS No. C65100), B124/B124M (Copper Alloy UNS Nos. C11000, C14500, C14700, C46400, C46750, C48200, C48500, C48640, C48645, C49250, C49255, C49260, C49265, C49300, C49340, C49345, C49350, and C49360), B140/B140M, B301/B301M, B453/B453M, B927/B927M, B967/B967M, and B974/B974M)

Diameter or Distance Between Parallel Surfaces, in. [mm]	Tolerances, Plus and Minus, <sup>A</sup> in. [mm]	
	Round	Hexagonal, Octagonal
Up to 0.150 [3.8], incl	0.0013 [0.035]	0.0025 [0.06]
Over 0.150 to 0.500 [3.8 to 12], incl	0.0015 [0.04]	0.003 [0.08]
Over 0.500 to 1.00 [12 to 25], incl	0.002 [0.05]	0.004 [0.10]
Over 1.00 to 2.00 [25 to 50], incl	0.0025 [0.06]	0.005 [0.13]
Over 2.00 [50]	0.15 <sup>B</sup> [0.15] <sup>B</sup>	0.30 <sup>B</sup> [0.30] <sup>B</sup>

<sup>A</sup> When tolerances are specified as all plus or all minus, double the values given.  
<sup>B</sup> Percent of specified diameter or distance between parallel surfaces expressed to the nearest 0.001 in. [0.01 mm].

**TABLE 2 Tolerances for Diameter or Distance Between Parallel Surfaces of Cold-Drawn Rod**

(Applicable to Specifications B98/B98M (Copper Alloy UNS Nos. C65500 and C66100), B124/B124M (Copper Alloy UNS Nos. C27450, C27453, C28500, C36300, C36500, C37000, C37700, C61900, C62300, C63000, C63200, C64200, C64210, C65500, C65680, C67500, C67600, C69240, C69300, C69410, C69850, C70620, C71520, and C77400), B138/B138M, B139/B139M, B150/B150M, B151/B151M, B196/B196M, B371/B371M, B411/B411M, B441, and B981/B981M)

Diameter or Distance Between Parallel Surfaces, in. [mm]	Tolerances, Plus and Minus, <sup>A</sup> in. [mm]	
	Round	Hexagonal, Octagonal
Up to 0.150 [3.8], incl	0.002 [0.050]	0.002 [0.050]
Over 0.150 to 0.500 [3.8 to 12], incl	0.002 [0.050]	0.004 [0.10]
Over 0.500 to 1.00 [12 to 25], incl	0.003 [0.08]	0.005 [0.13]
Over 1.00 to 2.00 [25 to 50], incl	0.004 [0.10]	0.006 [0.15]
Over 2.00 [50]	0.20 <sup>B</sup> [0.20] <sup>B</sup>	0.40 <sup>B</sup> [0.40] <sup>B</sup>

<sup>A</sup> When tolerances are specified as all plus or all minus, double the values given.  
<sup>B</sup> Percent of specified diameter or distance between parallel surfaces expressed to the nearest 0.001 in. [0.01 mm].

**TABLE 3 Diameter Tolerances for Piston-Finish Rod**

(Applicable to Specifications B21/B21M, B138/B138M, B139/B139M, and B150/B150M)

Diameter, in. [mm]	Tolerances, Plus and Minus, <sup>A</sup> in. [mm]
Over 0.500 to 1.00 [12 to 25], incl	0.0013 [0.35]
Over 1.00 to 2.00 [25 to 50], incl	0.0015 [0.04]
Over 2.00 [50]	0.10 <sup>B</sup> [0.10] <sup>B</sup>

<sup>A</sup> When tolerances are specified as all plus or all minus, double the values given.  
<sup>B</sup> Percent of specified diameter expressed to the nearest 0.0005 in. [0.01 mm].

**TABLE 4 Tolerances for Diameter or Distance Between Parallel Surfaces of As-Extruded Rod and Bar**

(Applicable to Specifications B21/B21M, B124/B124M (Copper Alloy UNS Nos. C27450, C27453, C28500, C36300, C36500, C37000, C37700, C46400, C46750, C48200, C48500, C48640, C48645, C49250, C49255, C49260, C49265, C49300, C49340, C49345, C49350, C49355, C49360, C61900, C62300, C63000, C63200, C64200, C64210, C67500, C67600, C69240, C69300, C69410, C69850, C70620, and C71520), B138/B138M (Copper Alloy UNS Nos. C67500 and C67600), B150/B150M, B967/B967M, and B981/B981M)

Diameter or Distance Between Parallel Surfaces, in. [mm]	Tolerances, Plus and Minus, <sup>A</sup> in. [mm]	
	Rod (Round, Hexagonal, and Octagonal) Bar (Rectangular and Square)	
Up to 1.00 [25], incl	0.010 [0.25]	
Over 1.00 to 2.00 [25 to 50], incl	0.015 [0.38]	
Over 2.00 to 3.00 [50 to 75], incl	0.025 [0.65]	
Over 3.00 to 3.50 [75 to 90], incl	0.035 [0.90]	
Over 3.50 to 4.00 [90 to 100], incl	0.060 [1.5]	

<sup>A</sup> When tolerances are specified as all plus or all minus, double the values given.

Table 7, Table 8 and Table 9—List the thickness tolerances for rectangular and square bar applicable to the product specifications and alloys shown in the table titles.

Table 10 and Table 11—List the width tolerances for rectangular bar applicable to the product specifications and alloys shown in the table titles.

**TABLE 5 Tolerances for Diameter or Distance Between Parallel Surfaces of As-Extruded Rod and Bar**

(Applicable to Specifications B98/B98M, B124/B124M (Copper UNS Nos. C11000, C14500, C14700 and Copper Alloy UNS Nos. C65500, C65680, C77400, C87700, and C87710), B138/B138M (Copper UNS No. C67000), B196/B196M, B441 and B929)

Diameter or Distance Between Parallel Surfaces, in. [mm]	Tolerances, Plus and Minus, <sup>A</sup> in. [mm]
	Rod (Round, Hexagonal, and Octagonal) Bar (Rectangular and Square)
Up to 1.00 [25], incl	0.020 [0.50]
Over 1.00 to 2.00 [25 to 50], incl	0.030 [0.75]
Over 2.00 to 3.00 [50 to 75], incl	0.050 [1.3]
Over 3.00 to 3.50 [75 to 90], incl	0.070 [1.8]
Over 3.50 to 4.00 [90 to 100], incl	0.120 [3.0]

<sup>A</sup> When tolerances are specified as all plus or all minus, double the values given.

**TABLE 6 Diameter Tolerances for Hot-Rolled Round Rod**  
(Applicable to Specifications B98/B98M, B124/B124M, B138/B138M, B150/B150M, B196/B196M, and B441)

Diameter, in. [mm]	Tolerances, Plus and Minus, <sup>A</sup> in. [mm]
0.250 [6.35] only	+0.020 [+0.50] -0.010 [-0.25]
Over 0.250 to 0.750 [6.35 to 20], incl	0.015 [0.38]
Over 0.750 to 1.25 [20 to 30], incl	0.020 [0.50]
Over 1.25 to 1.50 [30 to 38], incl	0.030 [0.75]
Over 1.50 to 3.00 [38 to 75], incl	1/16 [1.6]
Over 3.00 [75]	1/8 [3.2]

<sup>A</sup> When tolerances are specified as all plus or all minus, double the values given.

Table 12—Lists the diameter or distance between parallel surfaces tolerances for hot-forged rod and bar applicable to the product specification shown in the title.

6.3 *Length*—Rod, bar, and shapes shall be furnished in stock lengths with ends, unless the order specifies stock lengths, specific lengths, or specific lengths with ends as specified in Table 13, Table 14, and Table 15 for the product specification indicated.

Table 13—Length tolerances for full-length pieces applicable to product specifications shown in the table title.

Table 14 and Table 15—Lists the schedule of lengths (specific and stock) with ends applicable to product specifications and alloys shown in the table titles.

#### 6.4 *Straightness*:

6.4.1 Unless otherwise specified, drawn rod, bar, and shapes, other than shafting rod, piston-finish rod shall be furnished in straight lengths. The deviation from straightness shall not exceed the limitations specified in Table 16 for either general or automatic screw machine use for the product specifications and alloys shown in the table titles. To determine compliance with this tolerance, the lengths shall, in case of disagreement, be checked by the following method:

6.4.1.1 Place the lengths on a level table so that the arc or departure from straightness is horizontal. Measure the depth of arc to the nearest 1/32 in. [1.0 mm], using a steel scale and a straightedge. Local departure from straightness should be measured with a 1 ft [300 mm] straightedge and a feeler gage.

6.4.2 Shafting rod, when so specified, shall comply with the tolerances of Table 17 for the product specifications shown in

the table title. To determine compliance with this paragraph, shafting shall, in case of disagreement, be checked by the following method:

6.4.2.1 Place the shaft upon two freely rotating supports, one fourth of the shaft length extending beyond each support. Measure the departure from straightness at each end and at the center by means of a dial gage mounted on a suitable movable block and set successively at the three points to be measured while rotating the shaft slowly and carefully to avoid vibration. The total range of the dial reading at a given point, divided by two, gives the departure from straightness at that point.

#### 6.5 *Edge Contours*:

6.5.1 *Finish*—All rectangular and square bar shall have finished edges.

6.5.2 *Angles*—All regular polygonal sections shall have substantially exact angles. For hexagonal and octagonal rods cold-drawn to size, corner radii shall not exceed 1/16 in. [1.5 mm] for sizes up to 2 in. [50 mm], incl., and 3/32 in. [2.5 mm] for sizes over 2 in. [50 mm].

6.5.2.1 When specified, hexagons and octagons shall be furnished with corners rounded to a radius of 11 % of the distance between parallel faces. The distance from corner to corner (see Note 3) shall be the basis for acceptance or rejection. The appropriate tolerances are listed in Table 18.

NOTE 3—The distance from corner to corner is determined by calculating the distance across parallel faces times 1.121 for hexagons and 1.064 for octagons.

6.5.3 *Rectangular and Square Bar*—Unless otherwise specified, square corners shall be furnished on rectangular and square bar. When so ordered, the edge contours described in 6.5.4 – 6.5.7 inclusive shall be furnished.

6.5.4 *Square Corners*—Unless otherwise specified, bar shall be finished with commercially square corners with a maximum permissible radius of 1/32 in. [1.0 mm] for bars over 3/16 to 1 in. [5 to 25 mm], inclusive, in thickness, and 1/16 in. [1.5 mm] for bars over 1 in. [25 mm] in thickness.

6.5.5 *Rounded Corners*—When specified, bar shall be finished with corners rounded as shown in Fig. 1 to a quarter circle with a radius of 1/16 in. [1.5 mm] for bars over 3/16 to 1 in. [25 mm], inclusive, in thickness, and 1/8 in. [5 mm] for bars over 1 in. [25 mm] in thickness. The tolerance on the radius shall be ±25 %.

6.5.6 *Rounded Edge*—When specified bar shall be finished with edges rounded as shown in Fig. 2, the radius of curvature being 1/4 times the thickness of the bar for bars over 3/16 in. [5 mm] in thickness. The tolerance on the radius shall be one fourth the thickness of the bar.

6.5.7 *Full Rounded Edge*—When specified, bar shall be finished with substantially uniform round edges, the radius of curvature being approximately one half the thickness of the product, as shown in Fig. 3, but in no case to exceed one half the thickness of the product by more than 25 %.

## 7. Workmanship, Finish, and Appearance

7.1 *Workmanship*—The product shall be free of defects, but blemishes of a nature that do not interfere with the intended application are acceptable. The product shall be well cleaned and free from dirt.

**TABLE 7 Thickness Tolerances for Rectangular and Square Bar**

(Applicable to Specifications B124/B124M, (Copper Alloy UNS Nos. C11000, C14500, and C14700), B301/B301M, and B974/B974M)

Thickness, in. [mm]	Thickness Tolerances, Plus and Minus, <sup>A</sup> in. [mm] for Widths Given in Inches					
	½ [12] and Under	Over ½ to 1¼ [12 to 30] Incl	Over 1¼ to 2 [30 to 50] Incl	Over 2 to 4 [50 to 100] Incl	Over 4 to 8 [100 to 200] Incl	Over 8 to 12 [200 to 300] Incl
Over 0.188 to 0.500 [4.8 to 12], incl	0.003 [0.08]	0.003 [0.08]	0.0035 [0.09]	0.004 [0.10]	0.0045 [0.11]	0.0055 [0.13]
Over 0.500 to 1.00 [12 to 25], incl	...	0.004 [0.10]	0.004 [0.10]	0.0045 [0.11]	0.005 [0.13]	0.006 [0.15]
Over 1.00 to 2.00 [25 to 50], incl	...	0.0045 [0.11]	0.0045 [0.11]	0.005 [0.13]	0.006 [0.15]	...
Over 2.00 to 4.00 [50 to 100], incl	...	...	...	0.30 <sup>B</sup>	...	...

<sup>A</sup> When tolerances are specified as all plus or all minus, double the values given.

<sup>B</sup> Percent of specified thickness expressed to the nearest 0.001 in. [0.01 mm].

**TABLE 8 Thickness Tolerances for Rectangular and Square Bar**

(Applicable to Specifications B16/B16M, B21/B21M, B98/B98M, (Copper Alloy UNS No. 65100), B124/B124M (Copper Alloy UNS Nos. C46400, C46750, C48200, and C48500), B140/B140M, B453/B453M, B927/B927M, and B967/B967M)

Thickness, in. [mm]	Thickness Tolerances, Plus and Minus, <sup>A</sup> in. for Widths Given in Inches					
	½ and Under	Over ½ to 1¼ Incl	Over 1¼ to 2 Incl	Over 2 to 4 Incl	Over 4 to 8 Incl	Over 8 to 12 Incl
Over 0.188 to 0.500 [4.8 to 12], incl	0.0035 [0.09]	0.004 [0.10]	0.0045 [0.11]	0.0045 [0.11]	0.006 [0.13]	0.008 [0.20]
Over 0.500 to 1.00 [12 to 25], incl	...	0.0045 [0.11]	0.005 [0.13]	0.005 [0.13]	0.007 [0.18]	0.009 [0.23]
Over 1.00 to 2.00 [25 to 50], incl	...	0.005 [0.13]	0.005 [0.13]	0.006 [0.15]	0.008 [0.20]	...
Over 2.00 to 4.00 [50 to 100], incl	...	...	...	0.30 <sup>B</sup>	...	...

<sup>A</sup> When tolerances are specified as all plus or all minus, double the values given.

<sup>B</sup> Percent of specified thickness expressed to the nearest 0.001 in. [0.01 mm].

**TABLE 9 Thickness Tolerances for Rectangular and Square Bar**

(Applicable to Specifications B98/B98M (Copper Alloy UNS Nos. C65500 and C66100), B124/B124M (Copper Alloy UNS Nos. C27450, C27453, C28500, C36300, C36500, C37000, C37700, C48640, C48645, C65680, C61900, C62300, C63000, C63200, C64200, C64210, C65500, C67500, C67600, C69240, C69300, C69410, C69850, C70620, C75120, C77400, C87700, and C87710), B138/B138M, B139/B139M, B150/B150M, B151/B151M, B196/B196M, B411/B411M, B441, B929, and B981/B981M)

Thickness, in. [mm]	Thickness Tolerances, Plus and Minus, <sup>A</sup> in. [mm] for Widths Given in Inches					
	½ [12] and Under	Over ½ to 1¼ [12 to 30] Incl	Over 1¼ to 2 [30 to 50] Incl	Over 2 to 4 [50 to 100] Incl	Over 4 to 8 [100 to 200] Incl	Over 8 to 12 [200 to 300] Incl
Over 0.188 to 0.500 [4.8 to 12], incl	0.005 [0.13]	0.005 [0.13]	0.006 [0.15]	0.007 [0.18]	0.009 [0.23]	0.012 [0.30]
Over 0.500 to 1.00 [12 to 25], incl	...	0.006 [0.15]	0.007 [0.18]	0.008 [0.20]	0.010 [0.25]	0.013 [0.33]
Over 1.00 to 2.00 [25 to 50], incl	...	0.006 [0.15]	0.007 [0.18]	0.009 [0.23]	0.011 [0.28]	...
Over 2.00 to 4.00 [50 to 100], incl	...	...	...	0.50 <sup>B</sup>	...	...

<sup>A</sup> When tolerances are specified as all plus or all minus, double the values given.

<sup>B</sup> Percent of specified thickness expressed to the nearest 0.001 in. [0.1 mm].

**TABLE 10 Width Tolerances for Rectangular Bar**

(Applicable to Specifications B16/B16M, B21/B21M, B98/B98M (Copper Alloy UNS No. C65100), B124/B124M (Copper Alloy UNS Nos. C11000, C14500, C14700, C46400, C46750, C48200, and C48500), B140/B140M, B301/B301M, B453/B453M, B927/B927M, B967/B967M and B974/B974M)

Width, in. [mm]	Tolerances, Plus and Minus, <sup>A</sup> in. [mm]
Over 0.188 to 0.500 [4.8 to 12], incl	0.0035 [0.09]
Over 0.500 to 1.25 [12 to 30], incl	0.005 [0.13]
Over 1.25 to 2.00 [30 to 50], incl	0.008 [0.20]
Over 2.00 to 4.00 [50 to 100], incl	0.012 [0.30] <sup>B</sup>
Over 4.00 to 12.00 [100 to 300], incl	0.30 <sup>B</sup> [0.30]

<sup>A</sup> When tolerances are specified as all plus or all minus, double the values given.

<sup>B</sup> Percent of specified width expressed to the nearest 0.001 in. [0.01 mm].

**TABLE 11 Width Tolerances for Rectangular Bar**

(Applicable to Specifications B98/B98M (Copper Alloy UNS Nos. C65500 and C66100), B124/B124M (Copper Alloy UNS Nos. C27450, C27453, C28500, C36300, C36500, C37000, C37700, C48640, C48645, C65680, C61900, C62300, C63000, C63200, C64200, C64210, C65500, C67500, C67600, C69240, C69300, C69410, C69850, C70620, C75120, C77400, C87700, and C87710), B138/B138M, B139/B139M, B150/B150M, B151/B151M, B196/B196M, B411/B411M, B441, B929, and B981/B981M)

Width, in. [mm]	Tolerances, Plus and Minus, <sup>A</sup> in. [mm]
Over 0.188 to 0.500 [4.8 to 12], incl	0.005 [0.13]
Over 0.500 to 1.25 [12 to 30], incl	0.007 [0.18]
Over 1.25 to 2.00 [30 to 50], incl	0.010 [0.25]
Over 2.00 to 4.00 [50 to 100], incl	0.015 [0.38]
Over 4.00 to 12.00 [100 to 300], incl	0.50 <sup>B</sup> [0.50] <sup>B</sup>

<sup>A</sup> When tolerances are specified as all plus or all minus, double the values given.

<sup>B</sup> Percent of specified width expressed to the nearest 0.001 in. [0.01 mm].

7.2 *Finish*—A superficial film of residual light lubricant normally is present and is permissible unless otherwise specified.

7.3 *Appearance*:

7.3.1 The surface finish and appearance shall be of the normal quality for product ordered.

7.3.2 When intended application information is provided in the ordering information of the contract or purchase order, the surface shall be that normally produced for the application.

**TABLE 12 Diameter Tolerances for Hot-Forged Rod and Bar**  
(Applicable to Specification B138/B138M)

Diameter or Distance Between Parallel Surfaces, in. [mm]	Tolerances, All Plus, in. [mm]	
	As-Forged	Rough-Turned
Over 3.50 [90]	0.125 [3.2]	0.050 [1.3]

**TABLE 13 Length Tolerances for Rod, Bar, and Shapes (Full-Length Pieces Specific and Stock Lengths With or Without Ends)**  
(Applicable to Specifications B16/B16M, B21/B21M, B98/B98M, B138/B138M, B139/B139M, B140/B140M, B150/B150M, B151/B151M, B196/B196M, B301/B301M, B371/B371M, B411/B411M, B441, B453/B453M, B927/B927M, B929, B967/B967M, B974/B974M, and B981/B981M)

NOTE 1—The length tolerances in this table are all plus; if all minus tolerances are desired, use the same values; if tolerances are desired plus and minus, halve the values given.

Length Classification	Tolerances, All Plus, in. [mm] (Applicable Only to Full-Length Pieces)
Specific lengths	$\frac{3}{8}$ [10]
Specific lengths with ends	1 [25]
Stock lengths with or without ends	1 <sup>A</sup> [25] <sup>A</sup>

<sup>A</sup>As stock lengths are cut and placed in stock in advance of orders, departure from this tolerance is not practicable.

7.3.3 Superficial films of discoloration, or lubricants, or tarnish inhibitors are permissible unless otherwise specified.

## 8. Sampling

8.1 The lot size, portion size, and selection of sample pieces shall be as follows:

8.1.1 *Lot Size*—An inspection lot shall be 10 000 lb [5000 kg], or less, of the same mill form, alloy, temper, and nominal dimensions, subject to inspection at one time. Alternatively, a lot shall be the product of one cast bar from a single melt charge, or one continuous casting run whose weight does not exceed 40 000 lb [20 000 kg] that has been continuously processed and subject to inspection at one time.

8.1.2 *Portion Size*—The portion shall be four or more pieces selected as to be representative of each lot. Should the lot consist of less than five pieces, representative samples shall be taken from each piece.

### 8.2 Chemical Analysis:

8.2.1 The sample for chemical analysis shall be taken in accordance with Practice E255 for product in its final form from the pieces selected in 8.1.2 and combined into one composite sample. The minimum weight of the composite sample shall be 150 g.

8.2.2 Instead of sampling as directed in 8.2.1, the manufacturer shall have the option of sampling at the time castings are poured or from the semifinished product. When samples are taken during the course of manufacture, sampling of the finished product by the manufacturer is not required. The number of samples taken for the determination of composition shall be as follows:

8.2.2.1 When samples are taken at the time the castings are poured, at least one sample shall be taken for each group of castings poured from the same source of molten metal.

8.2.2.2 When samples are taken from semifinished product, a sample shall be taken to represent each 10 000 lb [5000 kg], or fraction thereof, except that not more than one sample shall be required per piece.

8.2.2.3 Only one sample need be taken from the semifinished product of one cast bar from a single melt charge continuously processed.

8.3 *Samples for All Other Tests*—Samples for all other tests shall be taken from the sample portions selected in 8.1.2 and be of a convenient size to accommodate the test and comply with the requirements of the appropriate product specification and test method.

## 9. Number of Tests and Retests

### 9.1 Tests:

9.1.1 *Chemical Analysis*—Chemical composition shall be determined as the per element mean of results from at least two replicate analyses of the sample(s) and the results of each replication shall meet the requirements of the product specification.

9.1.2 *Tensile Strength, Grain Size, Electrical Resistivity*—The test results for each individual test specimen shall be reported as the average of results obtained from specimens prepared from each of two pieces selected in 8.1.2 and each specimen must meet the requirements of the product specification. In the case of copper-beryllium alloy, two specimens shall be taken for each required test. One specimen from each piece shall be tested without further treatment, and the other specimen shall be tested after precipitation heat treatment.

9.1.2.1 *Rockwell Hardness*—The value of the hardness number of each specimen shall be established as the arithmetical average of at least three readings and each specimen must meet the requirements of the product specification.

9.1.2.2 *Bend, Cuprous Oxide (Hydrogen Embrittlement Susceptibility), and Mercurous Nitrate Tests*—All specimens tested must meet the product requirements to qualify for specification conformance.

9.1.3 *Other Requirements*—At least two specimens shall be subjected to test for each of the other requirements and each specimen shall conform to the test requirements.

### 9.2 Retests:

9.2.1 When requested by the manufacturer or supplier, a retest shall be permitted when test results obtained by the purchaser fail to conform with the product specification requirement(s).

9.2.2 Retesting shall be as directed in the product specification for the initial test except for the number of test specimens which shall be twice that normally required for the test. Test results for all specimens shall conform to the product specification requirement(s) in retest and failure to comply shall be cause for lot rejection.

## 10. Specimen Preparation

10.1 *Chemical Analysis*—Sample preparation shall be in accordance with Practice E255.

10.1.1 Analytical specimen preparation shall be the responsibility of the reporting laboratory.

**TABLE 14 Schedule of Lengths (Specific and Stock) with Ends for Rod, Bar, and Shapes**

(Applicable to Specifications B16/B16M, B21/B21M, B138/B138M (Copper Alloy UNS Nos. C67500 and C67600), B140/B140M, B301/B301M, B453/B453M, B927/B927M, and B974/B974M)

Diameter or Distance Between Parallel Surfaces for Round, Hexagonal, and Octagonal Rod, and Square Bar, in. [mm]	Rectangular Bar, Area, <sup>A</sup> in. <sup>2</sup> [mm <sup>2</sup> ]	Nominal Length, ft [mm]	Shortest Permissible Length, <sup>B</sup> % of Nominal Length	Maximum Permissible Weight of Ends, % of Lot Weight
0.500 [12] and under	0.250 [160] and under	6 to 14 [2000 to 4250], incl	75	20
Over 0.500 to 1.00 [12 to 25], incl	over 0.250 to 1.00 [160 to 650], incl	6 to 14 [2000 to 4250], incl	70	30
Over 1.00 to 1.50 [25 to 38], incl	over 1.00 to 2.25 [650 to 1500], incl	6 to 12 [2000 to 3750], incl	60	40
Over 1.50 to 2.00 [38 to 50], incl	over 2.25 to 4.00 [1500 to 2500], incl	6 to 12 [2000 to 3750], incl	50	45
Over 2.00 to 3.00 [50 to 75], incl	over 4.00 to 9.00 [2500 to 5850], incl	6 to 10 [2000 to 3000], incl	40	50

<sup>A</sup> Width times thickness, disregarding any rounded corners or edges.

<sup>B</sup> Expressed to the nearest 1/2 ft [150 mm].

**TABLE 15 Schedule of Lengths (Specific and Stock) with Ends for Rod, Bar, and Shapes**

(Applicable to Specifications B98/B98M, B138/B138M (Copper Alloy UNS No. C67000), B139/B139M, B150/B150M, B151/B151M, B196/B196M, B371/B371M, B411/B411M, B441, B929, B967/B967M, and B981/B981M)

Diameter or Distance Between Parallel Surfaces for Round, Hexagonal, and Octagonal Rod, and Square Bar, in. [mm]	Rectangular Bar, Area, <sup>A</sup> in. <sup>2</sup> [mm <sup>2</sup> ]	Nominal Length, ft [mm]	Shortest Permissible Length, <sup>B</sup> % of Nominal Length	Maximum Permissible Weight of Ends, % of Lot Weight
0.500 [12] and under	0.250 [160] and under	6 to 12 [2000 to 4000], incl	65	30
Over 0.500 to 1.00 [12 to 25], incl	over 0.250 to 1.00 [160 to 650], incl	6 to 12 [2000 to 4000], incl	60	40
Over 1.00 to 1.50 [25 to 38], incl	over 1.00 to 2.25 [650 to 1500], incl	6 to 10 [2000 to 3000], incl	50	50
Over 1.50 to 2.00 [38 to 50], incl	over 2.25 to 4.00 [1500 to 2500], incl	6 to 10 [2000 to 3000], incl	40	60

<sup>A</sup> Width times thickness, disregarding any rounded corners or edges.

<sup>B</sup> Expressed to the nearest 1/2 ft [150 mm].

**TABLE 16 Straightness Tolerances for Rod, Bar, and Shapes**

Form and Size, in. [mm]	Length, ft [mm]	Maximum Curvature (Depth of Arc), in. [mm]
FOR GENERAL USE		
(Applicable to Specifications B16/B16M, B21/B21M, B98/B98M, B138/B138M, B139/B139M, B140/B140M, B150/B150M, B151/B151M, B196/B196M, B301/B301M, B371/B371M, B411/B411M, B441, B453/B453M, B927/B927M, B929, B967/B967M, B974/B974M, and B981/B981M)		
Rod: drawn	up to 2 [600]	1/32 [0.80]
	incl 2 to 5 [600 to 1500]	1/32 in any 2 ft portion [0.80 in any 600 mm portion] <sup>A</sup>
	incl 5 to 10 [1500 to 3000]	1/8 in any 5 ft portion [3.0 in any 1500 mm portion] <sup>A</sup>
	10 [3000] and over	1/2 in any 10 ft portion [12 in any 3000 mm portion] <sup>A</sup>
Bar and shapes (rolled or drawn)	6 [2000] and over	1/2 in any 6 ft portion [12 in any 2000 mm portion] <sup>A,B</sup>
DRAWN ROD—FOR AUTOMATIC SCREW MACHINE USE		
(Applicable to Specifications B16/B16M, B140/B140M, B301/B301M, B453/B453M, B974/B974M, and B981/B981M)		
Round only:		
Under 1/4 [6.35]	10 [3000] and over	1/2 in any 10 ft portion [12 in any 3000 mm portion] <sup>A</sup>
1/4 [6.35] and over	10 [3000] and over	1/4 in any 10 ft portion [6.35 in any 3000 mm portion] <sup>A</sup>
Local departure from straightness, 1/4 [6.35] and over only	...	1/64 in any 1 ft portion of the total length [0.40 in any 300 mm portion of the total length]
Hexagonal and octagonal:		
Under 1/4 [6.35]	10 [3000] and over	1/2 in any 10 ft portion [12.7 in any 3000 mm portion] <sup>A</sup>
1/4 [6.35] and over	10 [3000] and over	3/8 in any 10 ft portion [9.5 in any 3000 mm portion] <sup>A</sup>

<sup>A</sup> Of total length.

<sup>B</sup> Applicable to any longitudinal surface or edge.

**TABLE 17 Straightness Tolerances for Shafting**

(Applicable to Specifications B21/B21M, B138/B138M, B139/B139M, and B150/B150M)

Length of Shaft, ft [mm]	Maximum Permissible Departure from Straightness of Either Center or End Portions, in. [mm]	Minimum Diameter Applicable for Length Indicated, in. [mm]
Up to 6 [2000], incl	0.005 [0.13]	1/2 [12]
7 [1750]	0.007 [0.18]	1/2 [12]
8 [2400]	0.009 [0.23]	1/2 [12]
9 [2750]	0.012 [0.30]	1/2 [12]
10 [3050]	0.014 [0.36]	1/2 [12]
11 [3350]	0.017 [0.43]	1/2 [12]
12 [3650]	0.020 [0.50]	1/2 [12]
14 [4250]	0.028 [0.63]	5/8 [16]
16 [4875]	0.036 [0.91]	3/4 [20]
18 [5500]	0.045 [1.14]	1 [25]
20 [6100]	0.055 [1.4]	1 1/4 [30]
22 [6700]	0.068 [1.73]	1 1/2 [40]
24 [7300]	0.078 [2.00]	1 3/4 [44]
26 [7900]	0.094 [2.38]	2 [50]

**TABLE 18 Tolerances for Rounded Corner Hexagons and Octagons**

Distance Between Parallel Faces, in. [mm]	Tolerances on Distance Across Corners (Plus and Minus), in. [mm]
Up to 1 1/16 [17.3], incl	0.008 [0.20]
Over 1 1/16 to 2 [17.3 to 50], incl	0.010 [0.25]
Over 2 [50]	0.5 %

Specimens; Specimens for Wire, Rod, and Bar; Specimens for Rectangular Bar; or Specimens for Shapes Structure or Other). Unless specified, tensile testing may be performed on unmachined samples by using the maximum gage length extensometers that will fit between the gripping devices. The testing facility must be able to demonstrate that there is no statistically significant difference between the unmachined test results and

10.2 *Tensile Test*—The test specimen shall conform to the requirements prescribed for the particular product in the Test Specimen Section of Test Methods E8/E8M (see Round

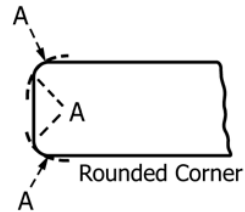

NOTE 1—The arc shall not necessarily be tangent at Points A but the product shall be commercially free from sharp, rough, or projecting edges.

FIG. 1 Rounded Corners

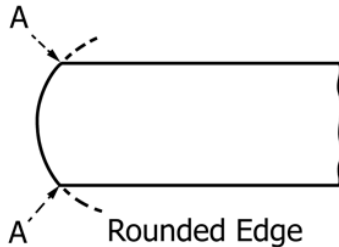

NOTE 1—The arc shall be substantially symmetrical with the axis of the product. The corners, A, will usually be sharp but shall not have rough or projecting edges.

FIG. 2 Rounded Edge



Full Rounded Edge

NOTE 1—The arc shall not necessarily be tangent at Point A but shall be substantially symmetrical with the axis of the product, and the product shall be commercially free from sharp, rough, or projecting edges.

FIG. 3 Full Rounded Edge

the standard test method defined in Test Methods E8/E8M. Statistical significance testing must follow Practice D4855.

10.3 *Grain Size*—The test specimen shall be prepared in accordance with Guide E3.

10.4 *Rockwell Hardness*—The test specimen shall be of a size and shape to permit testing by the available test equipment and shall be taken to permit testing in a plane parallel or perpendicular to the direction of deformation given to the product.

10.4.1 The surface of the test specimen shall be sufficiently smooth and even to permit the accurate determination of hardness.

10.4.2 The specimen shall be free of scale and foreign matter and care shall be taken to avoid any change in condition, that is, heating or cold work.

10.5 *Electrical Resistivity*—Test specimens are to be full size where practical and shall be the full cross section of the material it represents.

10.5.1 When the test specimen is cut from material in bulk, care shall be taken that the properties are not appreciably altered in the preparation. Plastic deformation may work

harden a material and tend to raise the resistivity, while heating tends to anneal the material with a consequent reduction in resistivity.

10.5.2 When necessary, products are to be rolled or cold-drawn to a wire approximately 0.080 in. (12 gage AWG) (2.0 mm) and at least 160 in. [4000 mm] in length. The specimen shall be annealed at approximately 935 °F ± 10 °F [500 °C ± 5 °C] for 30 min in an inert atmosphere and cooled to ambient temperature in the inert atmosphere.

10.5.3 For heat-treatable material, diameter and heat treatment shall be agreed upon between the manufacturer and the purchaser.

10.6 *Residual Stress Test*—When specified in the ordering information, test specimens shall conform to the requirements of Test Methods B154 or B858, as applicable.

10.6.1 Residual stress test specimens shall be of the full size of the product and tested without bending, springing, polishing, or any other preparation, except as allowed by the test method.

10.7 *Determination of Cuprous Oxide (Hydrogen Embrittlement Susceptibility) in Copper*—Test specimen shall conform to the appropriate requirements of the Test Specimen Section of Test Methods B577.

10.8 *Bend Test:*

10.8.1 The test specimen shall be prepared in accordance with Test Methods E290.

10.8.2 When impractical to test full-size specimens but practical to test full-thickness specimens from material not exceeding 1½ in. [40 mm] in nominal thickness, the specimens shall be of the thickness of the material and the ratio of width to thickness shall be 2:1, provided the width is not less than ¾ in. [20 mm].

10.8.3 When material exceeds ½ in. [10 mm] in thickness diameter, or distance across flats, the specimen may be machined when full-section or full-thickness specimen are not used. The diameter or thickness of the specimen shall be at least ½ in. [10 mm] and the ratio of width to thickness of rectangular specimens shall be 2:1. In rectangular specimens of reduced thickness, the outside or tension surface shall be an as fabricated surface.

10.9 *Replacement Specimens*—Should any test specimen show defective machining or develop flaws, it may be discarded and another specimen substituted.

## 11. Test Methods

11.1 The test method(s) used for quality control or production control, or both, for the determination of conformance with product property requirements are discretionary.

11.1.1 The test method(s) used to obtain data for the preparation of certification or test report, or both, shall be made available to the purchaser on request.

11.2 *Chemical Composition:*

11.2.1 In cases of disagreement, test methods for chemical analysis shall be subject to agreement between the manufacturer, or supplier and the purchaser. An applicable test method may be found in the following documents: Test Methods E53, E54, E62, E75, E76, E118, E121, E478, and E581.

11.2.1.1 The specific method to be used for each specified element may be prescribed in the product specification.

11.2.1.2 The test methods for the determination of composition for copper-beryllium alloys shall be as described in Annex A1 of Specification B194.

11.2.2 Test method(s) to be followed for the determination of element(s) resulting from contractual or purchase order agreement shall be as agreed upon between the manufacturer or supplier and the purchaser.

### 11.3 Other Tests:

11.3.1 The product in final form shall conform with physical, mechanical, and other requirements specified in the product specification when subjected to test in accordance with the appropriate test method in the following table:

Test	Test Methods
Grain size	E112
Electrical resistivity	B193
Tensile	E8/E8M
Rockwell hardness	E18
Hydrogen embrittlement	B577
Semi-guided bend	E290

11.3.2 *Grain Size*—The intercept method shall be used to determine grain size in case of dispute.

11.3.3 *Electrical Resistivity*—The limit of measurement uncertainty for Test Method B193 shall be  $\pm 0.30\%$  as a routine method and  $\pm 0.15\%$  as an umpire method.

### 11.3.4 Tensile:

11.3.4.1 The method to be used for determining yield strength shall be specified in the product specification.

11.3.4.2 Elongation shall be determined in accordance with the first two paragraphs of the subsection entitled “Elongation” of the Procedure section of Test Methods E8/E8M.

11.3.4.3 Whenever test results are obtained from both full-size and machined specimens and they differ, the test results from the full-size specimens shall prevail.

11.3.4.4 Test results are not seriously affected by variations in speed of testing. A considerable range of testing speed is permitted; however, the rate of stressing to the yield strength should not exceed 100 ksi/min. Above the yield strength the movement per minute of the testing machine head under load should not exceed 0.5 in./in. of gage length (or distance between grips for full-section specimens).

11.3.5 *Rockwell Hardness*—Special attention should be given to the Standardizing Machine section of Test Methods E18.

11.3.6 *Hydrogen Embrittlement*—In case of dispute, Procedure C, Closed Bend Test, of Test Methods B577 shall be used.

11.4 The product shall meet the performance requirements of the product specification when subjected to the following test as required:

### 11.4.1 Residual Stress Tests:

11.4.1.1 Unless otherwise agreed upon by the manufacturer or supplier and the purchaser, the manufacturer shall have the option of using either the mercurous nitrate test or the ammonia vapor test.

11.4.1.2 *Mercurous Nitrate Test*—The material shall be subjected to test in accordance with Test Method B154.

11.4.1.3 *Ammonia Vapor Test*—The material shall be subjected to test in accordance with Test Method B858. If the pH value is not specified in the product specification, it shall be established per agreement between the supplier and purchaser.

11.4.2 *Semiguided Bend Test*—The mandrel radius and bend angle shall be specified in the product specification. When the test specimen has been machined, the retained original surface shall constitute the outer periphery of the bend that shall be made on a radius equal to that dimension of the machined radial to the bend.

## 12. Significance of Numerical Limits

12.1 For the purpose of determining compliance with the specified limits for requirements of the properties listed in the following table and for dimensional tolerances, an observed value or a calculated value shall be rounded as indicated in accordance with the rounding method of Practice E29.

Property	Rounded Unit for Observed or Calculated Value
Chemical composition	
Hardness	nearest unit in the last right-hand significant digit used in expressing the limiting value
Electrical resistivity	
Electrical conductivity	
Tensile strength	nearest ksi [5 MPa]
Yield strength	
Elongation:	nearest 1 %
Grain size:	
Under 0.060 mm	nearest multiple of 0.005 mm
0.060 mm and over	nearest 0.01 mm

## 13. Inspection

13.1 The manufacturer or supplier shall inspect and make tests necessary to verify that the furnished product conforms to the specification requirements.

13.2 Source inspection of the product by the purchaser may be agreed upon between the manufacturer or supplier and the purchaser as part of the purchase order. In such case, the nature of the facilities needed to satisfy the inspector representing the purchaser that the product is being furnished in accordance with the product specification shall be included in the agreement. All testing and inspection shall be conducted so as not to interfere unnecessarily with the operations of the works.

13.3 When mutually agreed upon, the manufacturer or supplier and the purchaser may conduct the final inspection simultaneously.

## 14. Rejection and Rehearing

### 14.1 Rejection:

14.1.1 Product that fails to conform to the product specification requirements when tested by the purchaser or purchaser's agent shall be subject to rejection.

14.1.2 Rejection shall be reported to the manufacturer or supplier promptly. In addition, a written notification of rejection shall follow.

14.1.3 In case of dissatisfaction with the results of the test upon which rejection is based, the manufacturer or supplier shall have the option to make claim for a rehearing.

#### 14.2 Rehearing:

14.2.1 As a result of product rejection, the manufacturer or supplier shall have the option to make claim for a retest to be conducted by the manufacturer or supplier and the purchaser. Samples of the rejected product shall be taken in accordance with the product specification and subjected to test by both parties using the test method(s) specified in the product specification, or, alternately, upon agreement by both parties, an independent laboratory may be selected for the test(s) using the test method(s) specified in the product specification.

### 15. Certification

15.1 The purchaser shall be furnished certification that samples representing each lot have been tested and inspected as directed in the product specification and the requirements have been met.

15.2 DELETED

### 16. Mill Test Report

16.1 A report of test results shall be furnished.

### 17. Product Marking

17.1 Product identification marking shall be as required by the product specification.

### 18. Packaging and Package Marking

#### 18.1 Packaging:

18.1.1 The product shall be separated by size, composition, and temper, and prepared for shipment by common carrier in such a manner as to afford protection from the normal hazards of transportation.

18.1.2 When specified in the purchase order or contract, that product is purchased for agencies of the U.S. Government, the requirements of Practice B900 may apply.

18.2 *Package Marking*—Each shipping unit shall be legibly marked with the purchase order number, Copper or Copper Alloy UNS No., designation, temper, size, shape, gross and net weight, and name of supplier or manufacturer. The specification number shall be shown when specified.

### 19. Keywords

19.1 bar, general requirements; bar, rod, shapes, general requirements; rod, general requirements; shape, general requirements

## SUPPLEMENTARY REQUIREMENTS

The following supplementary requirements shall apply only when specified by the purchaser in the inquiry, contract, or order for agencies of the U.S. Government.

### S1. Referenced Documents

S1.1 The following documents of the issue in effect on date of material purchase form a part of this specification to the extent referenced herein:

#### S1.1.1 *ASTM Standard:*

B900 Practice for Packaging of Copper and Copper Alloy Mill Products for U.S. Government Agencies

#### S1.1.2 *Federal Standards:*

Fed. Std. No. 102 Preservation, Packaging, and Packing Levels

Fed. Std. No. 123 Marking for Shipment (Civil Agencies)

Fed. Std. No. 185 Identification Marking of Copper and Copper-Base Alloy Mill Products

#### S1.1.2 *Military Standard:*

MIL-STD-129 Marking for Shipment and Storage

### S2. Quality Assurance

#### S2.1 *Responsibility for Inspection:*

S2.1.1 Unless otherwise specified in the contract or purchase order, the manufacturer is responsible for the performance of all inspection and test requirements specified. Except as otherwise specified in the contract or purchase order, the manufacturer may use his own or any other suitable facilities

for the performance of the inspection and test requirements unless disapproved by the purchaser at the time the order is placed. The purchaser shall have the right to perform any of the inspections or tests set forth when such inspections and tests are deemed necessary to ensure that the material conforms to prescribed requirements.

### S3. Identification Marking

S3.1 All material shall be properly marked for identification in accordance with Fed. Std. No. 185 except that the ASTM specification number and the alloy number shall be used.

### S4. Preparation for Delivery

#### S4.1 *Preservation, Packaging, Packing:*

S4.1.1 *Military Agencies*—The material shall be separated by size, composition, grade or class, and shall be preserved and packaged, Level A or C, packed Level A, B, or C, as specified in the contract or purchase order, in accordance with the requirements of Practice B900.

S4.1.2 *Civil Agencies*—The requirements of Fed. Std. No. 102 shall be referenced for definitions of the various levels of packaging protection.

#### S4.2 *Marking:*

S4.2.1 *Military Agencies*—In addition to any special marking required by the contract or purchase order, marking for shipment shall be in accordance with MIL-STD-129.

S4.2.2 *Civil Agencies*—In addition to any special marking required by the contract or purchase order, marking for shipment shall be in accordance with Fed. Std. No. 123.

## APPENDIX

### (Nonmandatory Information)

#### X1. STANDARD DENSITIES

X1.1 For purposes of calculating weights, cross sections, and so forth, the densities of the coppers and copper alloys covered by the specifications listed in Section I shall be taken as follows:

ASMENORMDOC.COM : Click to view the full PDF of ASME BPVC.II.B (ASME BPVC Section II part B) 2025

TABLE X1.1 Densities of Coppers and Copper Alloys

ASTM Designation	Material	Copper or Copper Alloy UNS No.	Density, lb/in. <sup>3</sup> [g/cm <sup>3</sup> ]
B16/B16M	free-cutting brass	C36000	0.307 [8.50]
B21/B21M	naval brass	C46200	0.305 [8.44]
		C46400	0.304 [8.41]
		C48200	0.305 [8.42]
		C48500	0.305 [8.41]
	lead brass	C48640	0.303 [8.40]
		C48645	0.307 [8.49]
B98/B98M	copper-silicon alloy	C65100	0.316 [8.75]
		C65500	0.308 [8.53]
		C65800	0.308 [8.53]
		C66100	0.308 [8.53]
B124/B124M	copper	C11000	0.323 [8.94]
	copper-tellurium	C14500	0.323 [8.94]
	copper-sulfur	C14700	0.323 [8.94]
	plumbing brass	C27450	0.304 [8.41]
	copper-zinc alloy	C27453	0.305 [8.44]
	copper-zinc brass	C28500	0.303 [8.40]
	copper-zinc-lead	C36300	0.304 [8.41]
	forging brass	C37700	0.305 [8.44]
	naval brass	C46400	0.304 [8.41]
	tin brass	C46750	0.306 [8.48]
	medium lead brass	C48200	0.305 [8.44]
	lead brass	C48500	0.305 [8.44]
	lead brass	C48640	0.303 [8.40]
	lead brass	C48645	0.307 [8.49]
	bismuth brass	C49250	0.301 [8.41]
		C49255	0.304 [8.41]
		C49260	0.303 [8.40]
	low lead bismuth brass	C49265	0.303 [8.40]
	bismuth brass	C49300	0.304 [8.42]
		C49340	0.305 [8.45]
		C49345	0.305 [8.45]
	low lead bismuth brass	C49350	0.311 [8.45]
	bismuth brass	C49355	0.300 [8.30]
		C49360	0.304 [8.41]
		C61900	0.271 [7.5]
	aluminum-bronze	C62300	0.277 [7.66]
	aluminum-bronze, 9 %	C63000	0.274 [7.58]
	aluminum-nickel bronze	C64200	0.278 [7.69]
	aluminum-silicon bronze	C64210	0.278 [7.69]
	aluminum-silicon bronze, 6.7 %	C65500	0.308 [8.53]
	high-silicon bronze (A)	C65680	0.302 [8.35]
	silicon bronze	C67500	0.302 [8.36]
	manganese bronze (A)	C69240	0.301 [8.33]
	copper-zinc-silicon-manganese	C77400	0.306 [8.47]
B138/B138M	manganese bronze	C67000	0.286 [7.92]
		C67500	0.302 [8.36]
B139/B139M	phosphor bronze	C51000	0.320 [8.86]
		C52100	0.318 [8.80]
		C52400	0.317 [8.77]
		C53400	0.322 [8.91]
		C54400	0.320 [8.86]
B140/B140M	lead red brass	C31400	0.319 [8.83]
		C31600	0.320 [8.86]
		C32000	0.317 [8.77]
B150/B150M	aluminum bronze	C61300	0.285 [7.89]
		C61400	0.285 [7.89]
		C61900	0.270 [7.5]
		C62300	0.276 [7.66]
		C62400	0.269 [7.45]
		C63000	0.274 [7.58]
		C63200	0.276 [7.64]
		C64200	0.278 [7.69]
aluminum-silicon bronze, 6.7 %	C64210	0.278 [7.69]	

TABLE X1.1 Continued

ASTM Designation	Material	Copper or Copper Alloy UNS No.	Density, lb/in. <sup>3</sup> [g/cm <sup>3</sup> ]
B151/B151M	copper-nickel-zinc alloy (nickel sil- ver) and copper-nickel alloy	C70600	0.323 [8.94]
		C71500	0.323 [8.94]
		C72000	0.323 [8.94]
		C74500	0.313 [8.86]
		C75200	0.317 [8.77]
		C75700	0.314 [8.69]
		C76400	0.315 [8.72]
		C77000	0.314 [8.69]
		C79200	0.314 [8.69]
		C79400	0.317 [8.77]
B187/B187M	copper: deoxidized and oxygen-free other classifications	...	0.323 [8.94]
		...	0.321 [8.89]
B196/B196M	copper-beryllium alloy	C17000	0.297 [8.22]
		C17200	0.297 [8.22]
		C17300	0.297 [8.22]
B301/B301M	free-cutting copper	C14500	0.323 [8.94]
		C14700	0.323 [8.94]
		C14710	0.323 [8.94]
		C14720	0.323 [8.94]
		C18700	0.323 [8.94]
B371/B371M	copper-zinc-silicon alloy	C69400	0.296 [8.94]
		C69410	0.296 [8.19]
		C69700	0.300 [8.19]
		C69850	0.297 [8.22]
B411/B411M	copper-nickel-silicon alloy	C64700	0.322 [8.91]
B441	copper-cobalt-beryllium copper-nickel-beryllium	C17500	0.316 [8.75]
		C17510	0.316 [8.75]
B453/B453M	copper-zinc-lead (leaded brass)	C33500	0.306 [8.47]
		C34000	0.306 [8.47]
		C34500	0.306 [8.47]
		C35000	0.305 [8.44]
		C35300	0.306 [8.47]
		C35330	0.306 [8.47]
		C35600	0.307 [8.50]
B455	copper-zinc-lead (leaded brass)	C38000	0.305 [8.44]
		C38500	0.306 [8.47]
B929	copper-nickel-tin spinodal alloy	C72900	0.323 [8.94]
B967/B967M	bismuth brass  low leaded bismuth brass bismuth brass  low leaded bismuth brass bismuth brass	C49250	0.301 [8.41]
		C49255	0.304 [8.41]
		C49260	0.303 [8.40]
		C49265	0.303 [8.40]
		C49300	0.304 [8.42]
		C49340	0.305 [8.45]
		C49345	0.305 [8.45]
		C49350	0.305 [8.45]
		C49355	0.300 [8.30]
		C49360	0.304 [8.41]
B981/B981M	copper-zinc-lead (leaded brass)	C36300	0.304 [8.41]

# **SPECIFICATION FOR GENERAL REQUIREMENTS FOR WROUGHT SEAMLESS COPPER AND COPPER-ALLOY TUBE**



**SB-251/SB-251M**

(Identical with ASTM Specification B251/B251M-17 except that certification and test reports have been made mandatory.)

ASME NORMDOC.COM : Click to view the full PDF of ASME BPVC.II.B (ASME BPVC Section II part B) 2025

# Specification for General Requirements for Wrought Seamless Copper and Copper-Alloy Tube

## 1. Scope

1.1 This specification covers a group of general requirements common to several wrought product specifications. Unless otherwise specified in the purchase order, or in an individual specification, these general requirements shall apply to copper and copper-alloy tube supplied under Specifications B68/B68M, B75/B75M, B135/B135M, B466/B466M, B643 and B743.

1.2 The values stated in either SI units or inch-pound units are to be regarded separately as standard. The values stated in each system are not necessarily exact equivalents; therefore, to ensure conformance with the standard, each system shall be used independently of the other, and values from the two systems shall not be combined.

1.3 *This international standard was developed in accordance with internationally recognized principles on standardization established in the Decision on Principles for the Development of International Standards, Guides and Recommendations issued by the World Trade Organization Technical Barriers to Trade (TBT) Committee.*

## 2. Referenced Documents

2.1 The following documents of the issue in effect on date of material purchase form a part of this specification to the extent referenced herein:

### 2.2 ASTM Standards:

B68/B68M Specification for Seamless Copper Tube, Bright Annealed  
B75/B75M Specification for Seamless Copper Tube  
B135/B135M Specification for Seamless Brass Tube  
B153 Test Method for Expansion (Pin Test) of Copper and Copper-Alloy Pipe and Tubing

B154 Test Method for Mercurous Nitrate Test for Copper Alloys

B170 Specification for Oxygen-Free Electrolytic Copper—Refinery Shapes

B193 Test Method for Resistivity of Electrical Conductor Materials

B428 Test Method for Angle of Twist in Rectangular and Square Copper and Copper Alloy Tube

B466/B466M Specification for Seamless Copper-Nickel Pipe and Tube

B643 Specification for Copper-Beryllium Alloy Seamless Tube

B743 Specification for Seamless Copper Tube in Coils

B846 Terminology for Copper and Copper Alloys

E3 Guide for Preparation of Metallographic Specimens

E8/E8M Test Methods for Tension Testing of Metallic Materials

E18 Test Methods for Rockwell Hardness of Metallic Materials

E29 Practice for Using Significant Digits in Test Data to Determine Conformance with Specifications

E53 Test Method for Determination of Copper in Unalloyed Copper by Gravimetry

E62 Test Methods for Chemical Analysis of Copper and Copper Alloys (Photometric Methods) (Withdrawn 2010)

E112 Test Methods for Determining Average Grain Size

E255 Practice for Sampling Copper and Copper Alloys for the Determination of Chemical Composition

E478 Test Methods for Chemical Analysis of Copper Alloys

## 3. Terminology

3.1 For definitions of terms related to copper and copper alloys, refer to Terminology B846.

## 4. Materials and Manufacture

4.1 The material shall be of such quality and purity that the finished product shall have the properties and characteristics prescribed in the applicable product specification listed in Section 1.

4.2 The material shall be produced by either hot or cold working operations, or both. It shall be finished, unless otherwise specified, by such cold working and annealing or heat treatment as necessary to meet the properties specified.

**5. Dimensions and Permissible Variations**

**5.1 General:**

5.1.1 The standard method of specifying wall thickness shall be in decimal fractions of an inch or millimeter.

5.1.2 For the purpose of determining conformance with the dimensional requirements prescribed in this specification, any measured value outside the specified limiting values for any dimension shall be cause for rejection.

5.1.3 Tolerances on a given tube shall be specified with respect to any two, but not all three, of the following: outside diameter, inside diameter, wall thickness.

5.1.4 When round tube is ordered by outside and inside diameters, the maximum plus and minus deviation of the wall thickness from the nominal at any point shall not exceed the values given in Table 1 by more than 50 %.

NOTE 1—Blank spaces in the tolerance tables indicate either that the material is not generally available or that no tolerances have been established.

5.2 *Wall Thickness Tolerances for Copper and Copper-Alloy Tube*—Wall thickness tolerances applicable to Specifications B68/B68M, B75/B75M, B135/B135M, and B743 for round tubes only shall be in accordance with Table 1 or Table 2. Wall thickness tolerances for rectangular including square tube applicable to Specifications B75/B75M and B135/B135M shall be in accordance with Table 3 or Table 4.

5.3 *Diameter or Distance between Parallel Surfaces, Tolerances for Copper and Copper-Alloy Tube*—Diameter tolerances applicable to Specifications B68/B68M, B75/B75M, B135/B135M, and B743 for round tubes only shall be in accordance with Table 5 or Table 6. Tolerances on distance between parallel surfaces for rectangular including square tube applicable to Specifications B75/B75M and B135/B135M shall be in accordance with Table 7 and Table 8.

5.4 *Roundness (Applicable to Specifications B75/B75M, B135/B135M, and B466/B466M)*—For drawn unannealed tube in straight lengths, the roundness tolerances shall be as follows:

t/D (Ratio of Wall Thickness to Outside Diameter)	Roundness Tolerance as Percent of Outside Diameter (Expressed to the Nearest 0.001 in. [0.025 mm])
0.01 to 0.03, incl	1.5 [1.5]
Over 0.03 to 0.05, incl	1.0 [1.0]
Over 0.05 to 0.10, incl	0.8 or 0.002 in. [mm] whichever is greater
Over 0.10	0.7 or 0.002 in. [mm] whichever is greater

5.4.1 Compliance with the roundness tolerances shall be determined by taking measurements on the outside diameter only, irrespective of the manner in which the tube dimensions are specified. The deviation from roundness is measured as the difference between major and minor diameters as determined at any one cross section of the tube. The major and minor diameters are the diameters of two concentric circles just enclosing the outside surface of the tube at the cross section.

5.4.2 No tolerances have been established for as-extruded tube, redraw tube, annealed tube, any tube furnished in coils or drawn tube whose wall thickness is under 0.016 in. [0.4 mm].

**5.5 Length Tolerances:**

5.5.1 *Straight Lengths*—Length tolerances, straight lengths, applicable to Specifications B68/B68M, B75/B75M, B135/B135M, and B466/B466M shall be in accordance with Table 9 or Table 10.

5.5.2 *Schedule of Tube Lengths*—Specific and stock lengths of tube with ends, applicable to Specifications B68/B68M, B75/B75M, B135/B135M, and B466/B466M, shall be in accordance with Table 11 or Table 12. Tube in straight lengths shall be furnished in stock lengths with ends, unless the order requires specific lengths or specific lengths with ends.

5.6 *Squareness of Cut (Applicable to Specifications B68/B68M, B75/B75M, B135/B135M, and B466/B466M)*—For tube in straight lengths, the departure from squareness of the end of any tube shall not exceed the following:

**TABLE 1 Wall Thickness Tolerances for Copper and Copper-Alloy Tube—Inch-Pound Values**  
(Applicable to Specifications B68/B68M, B75/B75M, B135/B135M, and B743)

NOTE 1—*Maximum Deviation at Any Point*—The following tolerances are plus and minus; if tolerances all plus or all minus are desired, double the values given.

Wall Thickness, in.	Outside Diameter, in. <sup>A</sup>						
	1/32 to 1/8, incl	Over 1/8 to 5/16, incl	Over 3/8 to 1, incl	Over 1 to 2, incl	Over 2 to 4, incl	Over 4 to 7, incl	Over 7 to 10, incl
Up to 0.017, incl	0.002	0.001	0.0015	0.002	...	...	...
Over 0.017 to 0.024, incl	0.003	0.002	0.002	0.0025	...	...	...
Over 0.024 to 0.034, incl	0.003	0.0025	0.0025	0.003	0.004	...	...
Over 0.034 to 0.057, incl	0.003	0.003	0.0035	0.0035	0.005	0.007	...
Over 0.057 to 0.082, incl	...	0.0035	0.004	0.004	0.006	0.008	0.010
Over 0.082 to 0.119, incl	...	0.004	0.005	0.005	0.007	0.009	0.011
Over 0.119 to 0.164, incl	...	0.005	0.006	0.006	0.008	0.010	0.012
Over 0.164 to 0.219, incl	...	0.007	0.009	0.009	0.011	0.012	0.014
Over 0.219 to 0.283, incl	...	...	0.011	0.012	0.014	0.015	0.016
Over 0.283 to 0.379, incl	...	...	0.014	6 <sup>B</sup> %	6 <sup>B</sup> %	7 <sup>B</sup> %	7 <sup>B</sup> %
Over 0.379	...	...	...	6 <sup>B</sup> %	6 <sup>B</sup> %	7 <sup>B</sup> %	7 <sup>B</sup> %

<sup>A</sup> When round tube is ordered by outside and inside diameters, the maximum plus and minus deviation of the wall thickness from the nominal at any point shall not exceed the values given in the table by more than 50 %.

<sup>B</sup> Percent of specified wall expressed to the nearest 0.001 in.

**TABLE 2 Wall Thickness Tolerances for Copper and Copper-Alloy Tube—SI Values**  
(Applicable to Specifications B68/B68M, B75/B75M, and B135/B135M)

NOTE 1—*Maximum Deviation at Any Point*—The following tolerances are plus and minus; if tolerances all plus or all minus are desired, double the values given.

Wall Thickness, mm	Outside Diameter, mm <sup>A</sup>						
	0.80 to 3.0, incl	Over 3.0 to 16, incl	Over 16 to 25, incl	Over 25 to 50, incl	Over 50 to 100, incl	Over 100 to 180, incl	Over 180 to 250, incl
Up to 0.40, incl	0.05	0.03	0.04	0.05	...	...	...
Over 0.40 to 0.60, incl	0.08	0.05	0.05	0.06	...	...	...
Over 0.60 to 0.90, incl	0.08	0.06	0.06	0.08	0.10	...	...
Over 0.90 to 1.5, incl	0.08	0.08	0.09	0.09	0.12	0.20	...
Over 1.5 to 2.0, incl	...	0.09	0.10	0.10	0.15	0.20	0.25
Over 2.0 to 3.0, incl	...	0.10	0.12	0.12	0.20	0.20	0.28
Over 3.0 to 4.0, incl	...	0.12	0.15	0.15	0.20	0.25	0.30
Over 4.0 to 5.5, incl	...	0.20	0.20	0.20	0.25	0.30	0.35
Over 5.5 to 7.0, incl	...	...	0.25	0.25	0.30	0.35	0.40
Over 7.0 to 10, incl	...	...	0.30	5 <sup>B</sup> %	5 <sup>B</sup> %	6 <sup>B</sup> %	6 <sup>B</sup> %
Over 10	...	...	...	5 <sup>B</sup> %	5 <sup>B</sup> %	6 <sup>B</sup> %	6 <sup>B</sup> %

<sup>A</sup> When round tube is ordered by outside and inside diameters, the maximum plus and minus deviation of the wall thickness from the nominal at any point shall not exceed the values given in the table by more than 50 %.

<sup>B</sup> Percent of specified wall expressed to the nearest 0.025 mm.

**TABLE 3 Wall Thickness Tolerances for Copper and Copper-Alloy Rectangular and Square Tube—Inch-Pound Values**  
(Applicable to Specifications B75/B75M, B135/B135M, and B743)

NOTE 1—*Maximum Deviation at Any Point*—The following tolerances are plus and minus; if tolerances all plus or all minus are desired, double the values given.

Wall Thickness, in.	Distance Between Outside Parallel Surface, in. <sup>A</sup>						
	1/32 to 1/8, incl	Over 1/8 to 5/16, incl	Over 5/16 to 1, incl	Over 1 to 2, incl	Over 2 to 4, incl	Over 4 to 7, incl	Over 7 to 10, incl
Up to 0.017, incl	0.002	0.002	0.0025	0.003	...	...	...
Over 0.017 to 0.024, incl	0.003	0.0025	0.003	0.0035	...	...	...
Over 0.024 to 0.034, incl	0.0035	0.0035	0.0035	0.004	0.006	...	...
Over 0.034 to 0.057, incl	0.004	0.004	0.0045	0.005	0.007	0.009	...
Over 0.057 to 0.082, incl	...	0.005	0.006	0.007	0.008	0.010	0.012
Over 0.082 to 0.119, incl	...	0.007	0.008	0.009	0.010	0.012	0.014
Over 0.119 to 0.164, incl	...	0.009	0.010	0.011	0.012	0.014	0.016
Over 0.164 to 0.219, incl	...	0.011	0.012	0.013	0.015	0.017	0.019
Over 0.219 to 0.283, incl	...	...	0.015	0.016	0.018	0.020	0.022

<sup>A</sup> In the case of rectangular tube the major dimension determines the thickness tolerance applicable to all walls.

5.6.1 *Round Tube:*

Specified Outside Diameter, in. [mm]	Tolerance
Up to 5/8 [16], incl	0.010 in. [0.25 mm]
Over 5/8 [16]	0.016 in./in. [mm/mm] of diameter

5.6.2 *Rectangular and Square Tube:*

Specified Distance Between Major Outside Parallel Surfaces, in. [mm]	Tolerance
Up to 5/8 [16], incl	0.016 in. [0.40 mm]
Over 5/8 [16]	0.025 in./in. [mm/mm] of distance between outside parallel surfaces

5.7 *Straightness Tolerances:*

5.7.1 *Round Tubes*—For round tubes of any drawn temper, 1/4 to 3 1/2 in. [6 to 100 mm] in outside diameter, inclusive, but not redraw tube, extruded tube, or any annealed tube, the straightness tolerances applicable to Specifications B75/B75M,

B135/B135M, and B466/B466M shall be in accordance with Table 13 or Table 14.

5.7.2 *Rectangular and Square Tubes*—For rectangular and square tubes of any drawn temper, the straightness tolerance applicable to Specifications B75/B75M and B135/B135M shall be 1/2 in. [12 mm] maximum curvature (depth of arc) in any 6-ft [2000-mm] portion of the total length. (Not applicable to extruded tube, redraw tube, or any annealed tube.)

5.8 *Corner Radius, Rectangular and Square Tubes*—The permissible radii for commercially square corners applicable to Specifications B75/B75M and B135/B135M shall be in accordance with Table 15 or Table 16.

5.9 *Twist Tolerances, Rectangular and Square Tubes*—The maximum twist about the longitudinal axis of drawn temper rectangular and square tubes applicable to Specifications B75/

**TABLE 4 Wall Thickness Tolerances for Copper and Copper-Alloy Rectangular and Square Tube—SI Values**  
(Applicable to Specifications B75/B75M and B135/B135M)

NOTE 1—*Maximum Deviation at Any Point*—The following tolerances are plus and minus; if tolerances all plus or all minus are desired, double the values given.

Wall Thickness, mm	Distance Between Outside Parallel Surface, mm <sup>A</sup>						
	0.80 to 3.0, incl	3.0 to 16, incl	16 to 25, incl	25 to 50, incl	50 to 100, incl	100 to 180, incl	180 to 250, incl
Up to 0.40, incl	0.05	0.05	0.06	0.08	...	...	...
Over 0.40 to 0.60, incl	0.08	0.06	0.08	0.09	...	...	...
Over 0.60 to 0.90, incl	0.09	0.09	0.09	0.10	0.15	...	...
Over 0.90 to 1.5, incl	0.10	0.10	0.12	0.12	0.20	0.25	...
Over 1.5 to 2.0, incl	...	0.12	0.15	0.20	0.20	0.25	0.30
Over 2.0 to 3.0, incl	...	0.20	0.20	0.25	0.25	0.30	0.35
Over 3.0 to 4.0, incl	...	0.25	0.25	0.28	0.30	0.36	0.40
Over 4.0 to 5.5, incl	...	0.28	0.30	0.33	0.38	0.45	0.50
Over 5.5 to 7.0, incl	...	...	0.38	0.40	0.45	0.50	0.55

<sup>A</sup> In the case of rectangular tube, the major dimension determines the thickness tolerance applicable to all walls.

**TABLE 5 Average Diameter Tolerances for Copper and Copper-Alloy Tube<sup>A</sup>—Inch-Pound Values**  
(Applicable to Specifications B68/B68M, B75/B75M, B135/B135M, and B743)

Specified Diameter, in.	Tolerance, Plus and Minus, in.
Up to 1/8, incl	0.002
Over 1/8 to 5/8, incl	0.002
Over 5/8 to 1, incl	0.0025
Over 1 to 2, incl	0.003
Over 2 to 3, incl	0.004
Over 3 to 4, incl	0.005
Over 4 to 5, incl	0.006
Over 5 to 6, incl	0.007
Over 6 to 8, incl	0.008
Over 8 to 10, incl	0.010

<sup>A</sup> Applicable to inside or outside diameter.

**TABLE 6 Average Diameter Tolerances for Copper and Copper-Alloy Tube<sup>A</sup>—SI Values**  
(Applicable to Specifications B68/B68M, B75/B75M, and B135/B135M)

Specified Diameter, mm	Tolerance, Plus and Minus, mm
Up to 3.0, incl	0.05
Over 3.0 to 16, incl	0.05
Over 16 to 25, incl	0.06
Over 25 to 50, incl	0.08
Over 50 to 75, incl	0.10
Over 75 to 100, incl	0.12
Over 100 to 125, incl	0.15
Over 125 to 150, incl	0.18
Over 150 to 200, incl	0.20
Over 200 to 250, incl	0.25

<sup>A</sup> Applicable to inside or outside diameter.

B75M and B135/B135M shall not exceed 1°/ft [1°/300 mm] of length, measured to the nearest degree, and the total angle of twist shall not exceed 20° when measured in accordance with Test Method B428. The requirement is not applicable to tubes in the annealed temper or to tubes whose specified major dimension is less than 1/2 in. [12 mm].

## 6. Workmanship, Finish, and Appearance

6.1 The material shall be free of defects of a nature that interfere with normal commercial applications. It shall be well cleaned and free of dirt.

## 7. Sampling

7.1 *Sampling*—The lot, size, portion size, and selection of sample pieces shall be as follows:

7.1.1 *Lot Size*—For tube, the lot size shall be 10 000 lb [5000 kg] or fraction thereof.

7.1.2 *Portion Size*—Sample pieces shall be taken for test purposes from each lot according to the following schedule:

Number of Pieces in Lot	Number of Sample Pieces to be Taken <sup>A</sup>
1 to 50	1
51 to 200	2
201 to 1500	3
Over 1500	0.2 % of total number of pieces in the lot, but not to exceed 10 sample pieces

<sup>A</sup> Each sample piece shall be taken from a separate tube.

## 8. Number of Tests and Retests

8.1 *Chemical Analysis*—Samples for chemical analysis shall be taken in accordance with Practice E255. Drillings, millings, etc., shall be taken in approximately equal weight from each of the sample pieces selected in accordance with 7.1.2 and combined into one composite sample. The minimum weight of the composite sample that is to be divided into three equal parts shall be 150 g.

8.1.1 Instead of sampling in accordance with Practice E255, the manufacturer shall have the option of determining conformance to chemical composition as follows: Conformance shall be determined by the manufacturer by analyzing samples taken at the time the castings are poured or samples taken from the semi-finished product. If the manufacturer determines the chemical composition of the material during the course of manufacture, he shall not be required to sample and analyze the finished product. The number of samples taken for determination of chemical composition shall be as follows:

8.1.1.1 When samples are taken at the time the castings are poured, at least one sample shall be taken for each group of castings poured simultaneously from the same source of molten metal.

**TABLE 7 Tolerances on Distance Between Parallel Surfaces for Copper and Copper-Alloy Rectangular and Square Tube—Inch-Pound Values**

(Applicable to Specifications B75/B75M, B135/B135M, and B743)

NOTE 1—The following tolerances are plus and minus; if tolerances all plus or all minus are desired, double the values given.

Dimension <i>a</i> or <i>b</i> (see sketches), in.	Tolerances, in.
Up to 1/8, incl	0.003
Over 1/8 – 3/8, incl	0.004
Over 3/8 to 1, incl	0.005
Over 1 to 2, incl	0.006
Over 2 to 3, incl	0.007
Over 3 to 4, incl	0.008
Over 4 to 5, incl	0.009
Over 5 to 6, incl	0.010
Over 6 to 8, incl	0.011
Over 8 to 10, incl	0.012

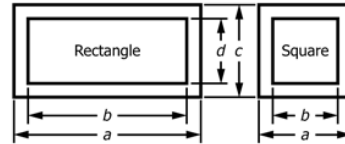

Nominal dimension *a* determines tolerance applicable to both *a* and *c*.  
Nominal dimension *b* determines tolerance applicable to both *b* and *d*.

**TABLE 8 Tolerances on Distance Between Parallel Surfaces for Copper and Copper-Alloy Rectangular and Square Tube—SI Values**

(Applicable to Specifications B75/B75M and B135/B135M)

NOTE 1—The following tolerances are plus and minus; if tolerances all plus or all minus are desired, double the values given.

Dimension <i>a</i> or <i>b</i> (see sketches), mm	Tolerances, mm
Up to 3.0, incl	0.08
Over 3.0 to 16, incl	0.10
Over 16 to 25, incl	0.12
Over 25 to 50, incl	0.15
Over 50 to 100, incl	0.20
Over 100 to 120, incl	0.25
Over 150 to 200, incl	0.30
Over 200 to 250, incl	0.30

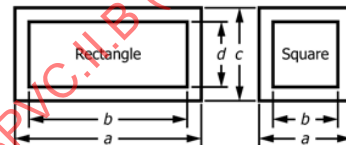

**TABLE 9 Length Tolerances for Copper and Copper-Alloy Tube, Straight Lengths—Inch-Pound Values**

(Applicable to Specifications B68/B68M, B75/B75M, B135/B135M, and B466/B466M)

NOTE 1—Tolerances are all plus; if all minus tolerances are desired, use the same values; if tolerances plus and minus are desired, halve the values given.

Length	Tolerances, in., Applicable Only to Full-Length Pieces		
	For Major Outside Dimensions Up to 1 in., incl	For Major Outside Dimensions Over 1 to 4 in., incl	For Major Outside Dimensions Over 4 in.
Specific lengths:			
Up to 6 in., incl	3/32	1/16	...
Over 6 in. to 2 ft, incl	1/16	3/32	1/8
Over 2 to 6 ft, incl	3/32	1/8	1/4
Over 6 to 14 ft, incl	1/4	1/4	1/4
Over 14 ft	1/2	1/2	1/2
Specific lengths with ends	1	1	1
Stock lengths with or without ends	1 <sup>A</sup>	1 <sup>A</sup>	1 <sup>A</sup>

<sup>A</sup> As stock lengths are cut and placed in stock in advance of orders, departure from this tolerance is not practicable.

**TABLE 10 Length Tolerances for Copper and Copper-Alloy Tube, Straight Lengths—SI Values**

(Applicable to Specifications B68/B68M, B75/B75M, B135/B135M, and B466/B466M)

NOTE 1—Tolerances are all plus; if all minus tolerances are desired, use the same values; if tolerances plus and minus are desired, halve the values given.

Length, mm	Tolerances, mm, Applicable Only to Full-Length Pieces		
	For Major Outside Dimensions Up to 25 mm, incl	For Major Outside Dimensions Over 25 to 100 mm, incl	For Major Outside Dimensions Over 100 mm
Specific lengths:			
Up to 150, incl	0.80	1.5	...
Over 150 to 600, incl	1.5	2.5	3.0
Over 600 to 2000, incl	2.5	3.0	6.0
Over 2000 to 4000, incl	6.0	6.0	6.0
Over 4000	12	12	12
Specific lengths with ends	25	25	25
Stock lengths with or without ends	25 <sup>A</sup>	25 <sup>A</sup>	25 <sup>A</sup>

<sup>A</sup> As stock lengths are cut and placed in stock in advance of orders, departure from this tolerance is not practicable.

8.1.1.2 When samples are taken from the semi-finished product, a sample shall be taken to represent each 10 000 lb [5000 kg] or fraction thereof, except that not more than one sample shall be required per piece.

8.1.1.3 Due to the discontinuous nature of the processing of castings into wrought products, it is not practical to identify specific casting analysis with a specific quantity of finished material.

**TABLE 11 Schedule of Tube Lengths (Specific and Stock) with Ends for Copper and Copper-Alloy Tube—Inch-Pound Values**  
(Applicable to Specifications B68/B68M, B75/B75M, B135/B135M and B466/B466M)

Major Outside Dimensions, in.	Specific Length, ft	Shortest Permissible Length, <sup>A</sup> % of Specific Length	Maximum Permissible Weight of Ends, % of Lot Weight
Up to 1, incl	6 to 20, incl	70	20
Over 1 to 2, incl	6 to 20, incl	60	25
Over 2 to 3, incl	6 to 20, incl	55	30
Over 3 to 4, incl	6 to 20, incl	50	40

<sup>A</sup> Expressed to the nearest 1/2 ft.

**TABLE 12 Schedule of Tube Lengths (Specific and Stock) with Ends for Copper and Copper-Alloy Tube—SI Values**  
(Applicable to Specifications B68/B68M, B75/B75M, B135/B135M and B466/B466M)

Major Outside Dimensions, mm	Specific Length, mm	Shortest Permissible Length, <sup>A</sup> % of Specific Length	Maximum Permissible Weight of Ends, % of Lot Weight
Up to 25, incl	2000 to 6000, incl	70	20
Over 25 to 50, incl	2000 to 6000, incl	60	25
Over 50 to 75, incl	2000 to 6000, incl	55	30
Over 75 to 100, incl	2000 to 6000, incl	50	40

<sup>A</sup> Expressed to the nearest 150 mm.

**TABLE 13 Straightness Tolerances for Copper and Copper-Alloy Tube<sup>A</sup> in Any Drawn Temper—Inch-Pound Values**  
(Applicable to Specifications B75/B75M, B135/B135M, B466/B466M and B643)

NOTE 1—Applies to round tube in any drawn temper from 1/4 [6.35] to 3/2 in. [88.9 mm], incl, in outside diameter.

Length, ft <sup>B</sup>	Maximum Curvature (Depth of Arc), in.
Over 3 to 6, incl	3/16
Over 6 to 8, incl	5/16
Over 8 to 10, incl	1/2

<sup>A</sup> Not applicable to pipe, redraw tube, extruded tube or any annealed tube.

<sup>B</sup> For lengths greater than 10 ft the maximum curvature shall not exceed 1/2 in. in any 10-ft portion of the total length.

**TABLE 14 Straightness Tolerances for Copper and Copper-Alloy Tube<sup>A</sup> in Any Drawn Temper—SI Values**  
(Applicable to Specifications B75/B75M, B135/B135M, B466/B466M and B643)

NOTE 1—Applies to round tube in any drawn temper from 6.0 to 100 mm, incl, in outside diameter.

Length, mm <sup>B</sup>	Maximum Curvature (Depth of Arc), mm
Over 1000 to 2000, incl	5.0
Over 2000 to 2500, incl	8.0
Over 2500 to 3000, incl	12

<sup>A</sup> Not applicable to pipe, redraw tube, extruded tube or any annealed tube.

<sup>B</sup> For lengths greater than 3000 mm the maximum curvature shall not exceed 12 mm in any 3000-mm portion of the total length.

8.1.1.4 In the event that heat identification or traceability is required, the purchaser shall specify the details desired.

8.2 *Other Tests*—For other tests, unless otherwise provided in the product specification, test specimens shall be taken from two of the sample pieces selected in accordance with 7.1.2.

**TABLE 15 Permissible Radii for Commercially Square Corners for Copper and Copper-Alloy Rectangular and Square Tube—Inch-Pound Values**  
(Applicable to Specifications B75/B75M, B135/B135M, and B743)

Wall Thickness, in.	Maximum Radii, in.	
	Outside Corners	Inside Corners
Up to 0.058, incl	3/64	1/32
Over 0.058 to 0.120, incl	1/16	1/32
Over 0.120 to 0.250, incl	3/32	1/32
Over 0.250	none established	none established

**TABLE 16 Permissible Radii for Commercially Square Corners for Copper and Copper-Alloy Rectangular and Square Tube—SI Values**  
(Applicable to Specifications B75/B75M and B135/B135M)

Wall Thickness, mm	Maximum Radii, mm	
	Outside Corners	Inside Corners
Up to 1.5, incl	1.2	0.80
Over 1.5 to 3.0, incl	1.6	0.80
Over 3.0 to 6.0, incl	2.4	0.80
Over 6.0	none established	none established

8.2.1 In the case of tube furnished in coils, a length sufficient for all necessary tests shall be cut from each coil selected for purpose of tests. The remaining portion of these coils shall be included in the shipment, and the permissible variations in length on such coils shall be waived.

### 8.3 Retests:

8.3.1 If any test specimen shows defective machining or develops flaws, it shall be discarded and another specimen substituted.

8.3.2 If the percentage elongation of any tension test specimen is less than that specified and any part of the fracture is outside the middle two thirds of the gage length or in a punched or scribed mark within the reduced section, a retest on an additional specimen either from the same sample piece or from a new sample piece shall be allowed.

8.3.3 If the results of the test on one of the specimens fail to meet the specified requirements, two additional specimens shall be taken from different sample pieces and tested. The results of the test on both of these specimens shall meet the specified requirements. Failure of more than one specimen to meet the specified requirements for a particular property shall be cause for rejection of the entire lot.

8.3.4 If the chemical analysis fails to conform to the specified limits, analysis shall be made on a new composite sample prepared from additional pieces selected in accordance with 7.1.2. The results of this retest shall comply with the specified requirements.

## 9. Test Specimens

9.1 Tension test specimens shall be of the full section of the tube and shall conform to the requirements of Test specimens section of Test Methods E8/E8M, unless the limitations of the testing machine preclude the use of such a specimen. Test specimens conforming to Type No. 1 of Fig. 13, Tension Test Specimens for Large-Diameter Tubular Products, of Test Methods E8/E8M shall be used when a full-section specimen cannot be tested.

9.2 Whenever tension test results are obtained from both full size and from machined test specimens and they differ, the results obtained from full-size test specimens shall be used to determine conformance to the specification requirements.

9.3 Tension test results on material covered by this specification are not seriously affected by variations in speed of testing. A considerable range of testing speed is permissible; however, the rate of stressing to the yield strength shall not exceed 100 ksi/min [700 MPa/min]. Above the yield strength the movement per minute of the testing machine head under load shall not exceed 0.5 in/in. [mm/mm] of gage length (or distance between grips for full-section specimens).

9.4 The surface of the test specimen for microscopical examination shall approximate a radial longitudinal section of round tube and a longitudinal section of rectangular and square tube perpendicular to, and bisecting, the major dimensional surface.

## 10. Test Methods

10.1 The properties enumerated in the specifications listed in Section 1 shall, in case of disagreement, be determined in accordance with the following applicable test methods:

Test	ASTM Designation
Chemical analysis	B170, <sup>A</sup> E53, E62, E478
Tension	E8/E8M
Rockwell hardness	E18 <sup>B</sup>
Grain size	E3, E112
Expansion (pin test)	B153
Mercurous nitrate test	B154
Electrical resistivity	B193

<sup>A</sup> Reference to Specification B170 is to the suggested chemical methods in the annex thereof. When Committee E01 has tested and published methods for assaying the low-level impurities in copper, the Specification B170 annex will be eliminated.

<sup>B</sup> The value for the Rockwell Hardness number of each specimen shall be established by taking the arithmetical average of at least three readings.

## 11. Significance of Numerical Limits

11.1 For purposes of determining compliance with the specified limits for requirements of the properties listed in the following table, an observed value or a calculated value shall be rounded as indicated in accordance with the rounding method of Practice E29:

Property	Rounded Unit for Observed or Calculated Value
Chemical composition	nearest unit in the last
Hardness	right-hand place of figures
Electrical resistivity	of the specified limit
Tensile strength	nearest ksi [nearest 5 MPa]
Yield strength	nearest ksi [nearest 5 MPa]
Elongation	nearest 1 %
Grain size:	
Up to 0.055 mm, incl	nearest multiple of 0.005 mm
Over 0.055 to 0.160 mm, incl	nearest 0.01 mm

## 12. Inspection

12.1 The manufacturer shall afford the inspector representing the purchaser, all reasonable facilities, without charge, to satisfy him that the material is being furnished in accordance with the specified requirements.

## 13. Rejection and Rehearing

13.1 Material that fails to conform to the requirements of this specification shall be subject to rejection. Rejection shall be reported to the manufacturer or supplier promptly and in writing. In case of dissatisfaction with the results of the test, the manufacturer or supplier shall have the option to make claim for a rehearing.

## 14. Certification

14.1 The manufacturer shall furnish to the purchaser a certificate stating that each lot has been sampled, tested, and inspected in accordance with this specification and has met the requirements.

14.2 DELETED

## 15. Packaging and Package Marking

15.1 The material shall be separated by size, composition, and temper, and prepared for shipment in such a manner as to ensure acceptance by common carrier for transportation and to afford protection from the normal hazards of transportation.

15.2 Each shipping unit shall be legibly marked with the purchase order number, metal or alloy designation, temper, size, shape, gross and net weight and name of supplier. The specification number shall be shown, when specified.

## 16. Mill Test Report

16.1 The manufacturer shall furnish to the purchaser a test report showing results of tests required by the specification.

## SUPPLEMENTARY REQUIREMENTS

The following supplementary requirements shall apply only when specified by the purchaser in the inquiry, contract, or order, for agencies of the U.S. Government.

### S1. Referenced Documents

S1.1 The following documents of the issue in effect on date of material purchase form a part of this specification to the extent referenced herein:

S1.1.1 ASTM Standard:

B900, Practice for Packaging of Copper and Copper Alloy Mill Products for U.S. Government Agencies.

S1.1.2 *Federal Standards*:

Fed. Std. No. 102 Preservation, Packaging and Packing Levels

Fed. Std. No. 123 Marking for Shipment (Civil Agencies)

Fed. Std. No. 185 Identification Marking of Copper and Copper-Base Alloy Mill Products

S1.1.3 *Military Standard*:

MIL-STD-129 Marking for Shipment and Storage

### S2. Quality Assurance

S2.1 *Responsibility for Inspection*:

S2.1.1 Unless otherwise specified in the contract or purchase order, the manufacturer is responsible for the performance of all inspection and test requirements specified. Except as otherwise specified in the contract or purchase order, the manufacturer shall use his own or any other suitable facilities for the performance of the inspection and test requirements

unless disapproved by the purchaser at the time the order is placed. The purchaser shall have the right to perform any of the inspections or tests set forth when such inspections and tests are deemed necessary to assure that the material conforms to prescribed requirements.

### S3. Identification Marking

S3.1 All material shall be properly marked for identification in accordance with Fed. Std. No. 185 except that the ASTM specification number and the alloy number shall be used.

### S4. Preparation for Delivery

S4.1 *Preservation, Packaging, Packing*:

S4.1.1 *Military Agencies*—The material shall be separated by size, composition, grade or class and shall be preserved and packaged, Level A or C, packed Level A, B, or C as specified in the contract or purchase order, in accordance with the requirements of Practice B900.

S4.1.2 *Civil Agencies*—The requirements of Fed. Std. No. 102 shall be referenced for definitions of the various levels of packaging protection.

S4.2 *Marking*:

S4.2.1 *Military Agencies*—In addition to any special marking required by the contract or purchase order, marking for shipment shall be in accordance with MIL-STD-129.

S4.2.2 *Civil Agencies*—In addition to any special marking required by the contract or purchase order, marking for shipment shall be in accordance with Fed. Std. No. 123.

## APPENDIX

(Nonmandatory Information)

### X1. STANDARD DENSITIES

X1.1 For reference purposes of calculating weights, cross sections, etc., the densities of the copper and copper alloys covered by the specifications listed in Section 1 shall be taken as in Table X1.1.

TABLE X1.1 Densities

ASTM Designation	Material	Copper or Copper Alloy UNS No.	Density, lb/in. <sup>3</sup>	Density, [g/cm <sup>3</sup> ]
B68/B68M	copper	C10100	0.323	[8.94]
B75/B75M	copper	C10200	0.323	[8.94]
B743	copper	C10300	0.323	[8.94]
		C10800	0.323	[8.94]
		C12000	0.323	[8.94]
		C12200	0.323	[8.94]
(B75/B75M only)		C14200	0.323	[8.94]
B135/B135M	brass	C22000	0.318	[8.80]
		C23000	0.316	[8.75]
		C26000	0.308	[8.53]
		C27000	0.306	[8.47]
		C27200	0.305	[8.44]
		C28000	0.303	[8.39]
		C33000	0.307	[8.50]
		C33200	0.308	[8.53]
		C37000	0.304	[8.41]
		C44300	0.308	[8.53]
B466	copper nickel	C70400	0.323	[8.94]
		C70600	0.323	[8.94]
		C71000	0.323	[8.94]
		C71500	0.323	[8.94]
		C72200	0.323	[8.94]

# SPECIFICATION FOR TITANIUM AND TITANIUM ALLOY STRIP, SHEET, AND PLATE



**SB-265**

(Identical with ASTM Specification B265-20a except that Note A in Table 7 has been revised.)

ASMENORMDOC.COM : Click to view the full PDF of ASME BPVC.II.B (ASME BPVC Section II part B) 2025

## Specification for Titanium and Titanium Alloy Strip, Sheet, and Plate

### 1. Scope

1.1 This specification covers annealed titanium and titanium alloy strip, sheet, and plate as follows:

- 1.1.1 *Grade 1*—UNS R50250. Unalloyed titanium,
- 1.1.2 *Grade 2*—UNS R50400. Unalloyed titanium,
  - 1.1.2.1 *Grade 2H*—UNS R50400. Unalloyed titanium (Grade 2 with 58 ksi (400 MPa) minimum UTS),
- 1.1.3 *Grade 3*—UNS R50550. Unalloyed titanium,
- 1.1.4 *Grade 4*—UNS R50700. Unalloyed titanium,
- 1.1.5 *Grade 5*—UNS R56400. Titanium alloy (6 % aluminum, 4 % vanadium),
- 1.1.6 *Grade 6*—UNS R54520. Titanium alloy (5 % aluminum, 2.5 % tin),
- 1.1.7 *Grade 7*—UNS R52400. Unalloyed titanium plus 0.12 to 0.25 % palladium,
  - 1.1.7.1 *Grade 7H*—UNS R52400. Unalloyed titanium plus 0.12 to 0.25 % palladium (Grade 7 with 58 ksi (400 MPa) minimum UTS),
- 1.1.8 *Grade 9*—UNS R56320. Titanium alloy (3.0 % aluminum, 2.5 % vanadium),
- 1.1.9 *Grade 11*—UNS R52250. Unalloyed titanium plus 0.12 to 0.25 % palladium,
- 1.1.10 *Grade 12*—UNS R53400. Titanium alloy (0.3 % molybdenum, 0.8 % nickel),
- 1.1.11 *Grade 13*—UNS R53413. Titanium alloy (0.5 % nickel, 0.05 % ruthenium),
- 1.1.12 *Grade 14*—UNS R53414. Titanium alloy (0.5 % nickel, 0.05 % ruthenium),
- 1.1.13 *Grade 15*—UNS R53415. Titanium alloy (0.5 % nickel, 0.05 % ruthenium),
- 1.1.14 *Grade 16*—UNS R52402. Unalloyed titanium plus 0.04 to 0.08 % palladium,
  - 1.1.14.1 *Grade 16H*—UNS R52402. Unalloyed titanium plus 0.04 to 0.08 % palladium (Grade 16 with 58 ksi (400 MPa) minimum UTS),

1.1.15 *Grade 17*—UNS R52252. Unalloyed titanium plus 0.04 to 0.08 % palladium,

1.1.16 *Grade 18*—UNS R56322. Titanium alloy (3 % aluminum, 2.5 % vanadium) plus 0.04 to 0.08 % palladium,

1.1.17 *Grade 19*—UNS R58640. Titanium alloy (3 % aluminum, 8 % vanadium, 6 % chromium, 4 % zirconium, 4 % molybdenum),

1.1.18 *Grade 20*—UNS R58645. Titanium alloy (3 % aluminum, 8 % vanadium, 6 % chromium, 4 % zirconium, 4 % molybdenum) plus 0.04 % to 0.08 % palladium,

1.1.19 *Grade 21*—UNS R58210. Titanium alloy (15 % molybdenum, 3 % aluminum, 2.7 % niobium, 0.25 % silicon),

1.1.20 *Grade 23*—UNS R56407. Titanium alloy (6 % aluminum, 4 % vanadium with extra low interstitial elements, ELI),

1.1.21 *Grade 24*—UNS R56405. Titanium alloy (6 % aluminum, 4 % vanadium) plus 0.04 % to 0.08 % palladium,

1.1.22 *Grade 25*—UNS R56403. Titanium alloy (6 % aluminum, 4 % vanadium) plus 0.3 % to 0.8 % nickel and 0.04 % to 0.08 % palladium,

1.1.23 *Grade 26*—UNS R52404. Unalloyed titanium plus 0.08 to 0.14 % ruthenium,

1.1.23.1 *Grade 26H*—UNS R52404. Unalloyed titanium plus 0.08 to 0.14 % ruthenium (Grade 26 with 58 ksi (400 MPa) minimum UTS),

1.1.24 *Grade 27*—UNS R52254. Unalloyed titanium plus 0.08 to 0.14 % ruthenium,

1.1.25 *Grade 28*—UNS R56323. Titanium alloy (3 % aluminum, 2.5 % vanadium) plus 0.08 to 0.14 % ruthenium,

1.1.26 *Grade 29*—UNS R56404. Titanium alloy (6 % aluminum, 4 % vanadium with extra low interstitial elements, ELI) plus 0.08 to 0.14 % ruthenium,

1.1.27 *Grade 30*—UNS R53530. Titanium alloy (0.3 % cobalt, 0.05 % palladium),

1.1.28 *Grade 31*—UNS R53532. Titanium alloy (0.3 % cobalt, 0.05 % palladium),

1.1.29 *Grade 32*—UNS R55111. Titanium alloy (5 % aluminum, 1 % tin, 1 % zirconium, 1 % vanadium, 0.8 % molybdenum),

1.1.30 *Grade 33*—UNS R53442. Titanium alloy (0.4 % nickel, 0.015 % palladium, 0.025 % ruthenium, 0.15 % chromium),

1.1.31 *Grade 34*—UNS R53445. Titanium alloy (0.4 % nickel, 0.015 % palladium, 0.025 % ruthenium, 0.15 % chromium),

1.1.32 *Grade 35*—UNS R56340. Titanium alloy (4.5 % aluminum, 2 % molybdenum, 1.6 % vanadium, 0.5 % iron, 0.3 % silicon),

1.1.33 *Grade 36*—UNS R58450. Titanium alloy (45 % niobium),

1.1.34 *Grade 37*—UNS R52815. Titanium alloy (1.5 % aluminum),

1.1.35 *Grade 38*—UNS R54250. Titanium alloy (4 % aluminum, 2.5 % vanadium, 1.5 % iron),

1.1.36 *Grade 39*—UNS R53390. Titanium alloy (0.25 % iron, 0.4 % silicon), and

1.1.37 *Grade 40*—UNS R54407. Titanium alloy (3.9 % vanadium, 0.85 % aluminum, 0.25 % iron, 0.25 % silicon).

NOTE 1—H grade material is identical to the corresponding numeric grade (that is, Grade 2H = Grade 2) except for the higher guaranteed minimum UTS, and may always be certified as meeting the requirements of its corresponding numeric grade. Grades 2H, 7H, 16H, and 26H are intended primarily for pressure vessel use.

1.2 The values stated in inch-pound units are to be regarded as standard. The values given in parentheses are mathematical conversions to SI units that are provided for information only and are not considered standard.

1.3 *This international standard was developed in accordance with internationally recognized principles on standardization established in the Decision on Principles for the Development of International Standards, Guides and Recommendations issued by the World Trade Organization Technical Barriers to Trade (TBT) Committee.*

**2. Referenced Documents**

2.1 *ASTM Standards:*

E8 Test Methods for Tension Testing of Metallic Materials [Metric] E0008\_E0008M

E29 Practice for Using Significant Digits in Test Data to Determine Conformance with Specifications

E290 Test Methods for Bend Testing of Material for Ductility

E539 Test Method for Analysis of Titanium Alloys by Wavelength Dispersive X-Ray Fluorescence Spectrometry

E1409 Test Method for Determination of Oxygen and Nitrogen in Titanium and Titanium Alloys by Inert Gas Fusion

E1447 Test Method for Determination of Hydrogen in Titanium and Titanium Alloys by Inert Gas Fusion Thermal Conductivity/Infrared Detection Method

E1941 Test Method for Determination of Carbon in Refractory and Reactive Metals and Their Alloys by Combustion Analysis

E2371 Test Method for Analysis of Titanium and Titanium Alloys by Direct Current Plasma and Inductively Coupled Plasma Atomic Emission Spectrometry (Performance-Based Test Methodology)

E2626 Guide for Spectrometric Analysis of Reactive and Refractory Metals (Withdrawn 2017)

**3. Terminology**

3.1 *Definitions of Terms Specific to This Standard:*

3.1.1 Any product 0.187 in. (4.75 mm) and under in thickness and less than 24 in. (610 mm) in width is classified as strip; products 0.187 in. (4.75 mm) and under in thickness and 24 in. (610 mm) or more in width are classified as sheet; any product over 0.187 in. (4.75 mm) in thickness and over 10 in. (254 mm) in width is classified as plate.

**4. Ordering Information**

4.1 Orders for materials under this specification shall include the following information as applicable:

4.1.1 Grade number (Section 1),

4.1.2 Product limitations (Section 3),

4.1.2.1 For sheet specify cold or hot rolled. If not specified cold tolerances are the default.

(a) Cold rolled sheet tolerances are in Table 1, Table 2, and

**TABLE 1 Permissible Variations in Thickness of Titanium Sheet**

Specified Thickness, in. (mm)	Permissible Variations in Thickness, Plus and minus, in. (mm)		Permissible Variations in Thickness Plus and minus, in. (mm) For hot rolled sheet	
	For cold rolled sheet	Width to 84 in. (2134 mm), incl	Width Over 84 in. (2134 mm)	
			Width to 84 in. (2134 mm), incl	Width Over 84 in. (2134 mm)
0.146 to 0.1875 (3.71 to 4.76), excl	0.014 (0.36)	0.025 (0.64)	0.028 (0.71)	
0.131 to 0.145 (3.33 to 3.68)	0.012 (0.31)	0.022 (0.558)	0.028 (0.71)	
0.115 to 0.130 (2.92 to 3.30)	0.010 (0.25)	0.020 (0.508)	...	
0.099 to 0.114 (2.51 to 2.90)	0.009 (0.23)	...	...	
0.084 to 0.098 (2.13 to 2.49)	0.008 (0.20)	...	...	
0.073 to 0.083 (1.85 to 2.11)	0.007 (0.18)	...	...	
0.059 to 0.072 (1.50 to 1.83)	0.006 (0.15)	...	...	
0.041 to 0.058 (1.04 to 1.47)	0.005 (0.13)	...	...	
0.027 to 0.040 (0.69 to 1.02)	0.004 (0.10)	...	...	
0.017 to 0.026 (0.43 to 0.66)	0.003 (0.08)	...	...	
0.008 to 0.016 (0.20 to 0.41)	0.002 (0.05)	...	...	
0.006 to 0.007 (0.15 to 0.18)	0.0015 (0.04)	...	...	
0.005 (0.13)	0.001 (0.03)	...	...	

**TABLE 2 Permissible Variations in Width and Length of Cold Rolled Titanium Sheet**

Specified Width, in. (mm), for Thicknesses Under 3/16 in.	Permissible Variations in Width, in. (mm)
24 to 48 (610 to 1220), excl	+1/16 (+1.60), -0
48 (1220) and over	+1/8 (+3.20), -0
Specified Length, ft (m)	Permissible Variations in Length, in. (mm)
Up to 10 (3)	+1/4 (+6.35), -0
Over 10 to 20 (3 to 6)	+1/2 (+12.7), -0

Table 3.

(b) Hot rolled sheet tolerances are in Table 1, Table 4, Table 5, and Table 6.

- 4.1.3 Special mechanical properties (Table 7),
- 4.1.4 Marking (Section 16),
- 4.1.5 Finish (Section 8),
- 4.1.6 Packaging (Section 16),
- 4.1.7 Additional required reports (Section 15), and
- 4.1.8 Disposition of rejected material (Section 14).

**5. Chemical Composition**

5.1 The grades of titanium and titanium alloy metal covered by this specification shall conform to the chemical composition requirements prescribed in Table 8.

5.1.1 The elements listed in Table 8 are intentional alloy additions or elements which are inherent to the manufacture of titanium sponge, ingot or mill product.

5.1.1.1 Elements other than those listed in Table 8 are deemed to be capable of occurring in the grades listed in Table 8 by and only by way of unregulated or unanalyzed scrap additions to the ingot melt. Therefore, product analysis for elements not listed in Table 8 shall not be required unless specified and shall be considered to be in excess of the intent of this specification.

5.1.2 Elements intentionally added to the melt must be identified, analyzed, and reported in the chemical analysis.

5.2 When agreed upon by producer and purchaser and requested by the purchaser in his written purchase order, chemical analysis shall be completed for specific residual elements not listed in this specification.

5.3 *Product Analysis*—Product analysis tolerances do not broaden the specified heat analysis requirements but cover variations between laboratories in the measurement of chemical content. The manufacturer shall not ship material that is

**TABLE 3 Permissible Variations in Weight of Cold Rolled Titanium Sheet**

The actual weight of any one item of an ordered thickness and size in any finish is limited in overweight by the following tolerance:
Any item of five sheets or less, or any item estimated to weigh 200 lb (91 kg) or less, may actually weigh as much as 10 % over the estimated weight.
Any item of more than five sheets and estimated to weigh more than 200 lb may actually weigh as much as 7 1/2 % over the estimated weight.
There is no under tolerance in weight for titanium sheets, under tolerance being restricted by the permissible thickness variations.
Only random (or mill size) sheets may be ordered on a square foot basis, and the number of square feet shipped may exceed the number ordered by as much as 5 %.

**TABLE 4 Permissible Variations in Width and Length of Hot Rolled Titanium Sheet**

Specified Length, in. (mm)	Specified Width, in. (mm)	Permissible Variations in. (mm)	
		Width	Length
Under 120 (3048)	Under 60 (1524)	+5/8 (15.88), +0	+3/4 (19.05), 0
	60 to 84 (1524 to 2134), excl	+11/16 (17.46), +0	+7/8 (22.23), 0
	84 to 108 (2134 to 2743), excl	+3/4 (19.05), +0	+1 (25.40), 0
120 to 240 (3048 to 6096), excl	Under 60 (1524)	+5/8 (15.88), +0	+1 (25.40), 0
	60 to 84 (1524 to 2134), excl	+3/4 (19.05), +0	+1 (25.40), 0
	84 to 108 (2134 to 2743), excl	+13/16 (20.64), +0	+1 1/8 (28.58), 0
240 to 360 (6098 to 9144), excl	Under 60 (1524)	+5/8 (15.88), +0	+1 1/4 (31.75), 0
	60 to 84 (1524 to 2134), excl	+3/4 (19.05), +0	+1 1/4 (31.75), 0
	84 to 108 (2134 to 2743), excl	+13/16 (20.64), +0	+1 1/4 (31.75), 0
360 to 480 (9144 to 12192) and over	Under 60 (1524)	+11/16 (17.46), +0	+1 3/8 (34.93), 0
	60 to 84 (1524 to 2134), excl	+3/4 (19.05), +0	+1 1/2 (38.10), 0
	84 to 108 (2134 to 2743), excl	+13/16 (20.64), +0	+1 1/2 (38.10), 0

**TABLE 5 Permissible Variations in Weight of Hot Rolled Titanium Sheet**

The actual weight of any one item or an order's thickness and size in any finish is limited in overweight by as much as 20 %.

outside the limits specified in Table 8 for the applicable grade. Product analysis limits shall be as specified in Table 9.

5.4 At least two samples for chemical analysis shall be tested to determine chemical composition. Samples shall be taken from the ingot or the extremes of the product to be analyzed.

**6. Mechanical Properties**

6.1 Material supplied under this specification shall conform to the mechanical property requirements given in Table 7 for the grade specified.

6.2 Tension testing specimens are to be machined and tested in accordance with Test Methods E8. Tensile properties shall be determined using a strain rate of 0.003 to 0.007 in./in./min through the specified yield strength, and then increasing the rate so as to produce failure in approximately one additional minute.

6.3 For sheet and strip, the bend test specimen shall withstand being bent cold through an angle of 105° without fracture in the outside of the bent portion. The bend shall be made on a **radius** equal to that shown in Table 7 for the applicable grade. The bends are to be made in accordance with Test Method E290, using Method 1, Guided Bend Test described in paragraph 3.6, bent through 105°, and allowed to spring back naturally. The surface of the specimen must include the original material surface with no material removal or surface conditioning, except corners may be rounded to a maximum radius of 0.032 in. (0.8 mm). The width of the bend shall be at

**TABLE 6 Permissible Variations from a Flat Surface for Titanium Hot Rolled Sheet**

Specified Thickness, in. (mm)	Permissible Variations from a Flat Surface for Width or Length Given, in. (mm)								
	48 (1219) or Under	48, excl to 60 (1219 to 1524), excl	60 to 72, (1524 to 1829), excl	72 to 84 (1829 to 2134), excl	84 to 96 (2134 to 2438), excl	96 to 108 (2438 to 2743), excl	108 to 120 (2743 to 3048), excl	120 to 144 (3048 to 3658), excl	144 (3658) and Over
0.146 to 0.1875 (3.71 to 4.76)	¾ (19.05)	1½ (26.99)	1¼ (31.75)	1⅝ (34.92)	1⅞ (41.28)	1⅞ (41.28)	1⅞ (47.6)	2 (50.8)	2¼ (57.15)
0.131 to 0.145 (3.33 to 3.68)	¾ (19.05)	1½ (26.99)	1¼ (31.75)	1⅝ (34.92)	1⅞ (41.28)	1⅞ (41.28)	1⅞ (47.6)	2 (50.8)	2½ (53.98)
0.115 to 0.130 (2.92 to 3.30)	¾ (19.05)	1½ (26.99)	1¼ (31.75)	1⅝ (34.92)	1⅞ (41.28)	1⅞ (41.28)	1⅞ (47.6)	2 (50.8)	2½ (53.98)

NOTE 1—Variations in flatness apply to plates up to 15 ft (4.57 m) in length, or to any 15 ft of longer plates.

NOTE 2—If the longer dimension is under 36 in. (914 mm) the variation is not greater than ¼ in. (6.35) mm.

NOTE 3—The shorter dimension specified is considered the width and the variation in flatness across the width does not exceed the tabular amount for that dimension.

NOTE 4—The maximum deviation from a flat surface does not customarily exceed the tabular tolerance for the longer dimension specified.

least 5 times the thickness. The test report shall, at minimum, indicate acceptable or unacceptable results.

## 7. Permissible Variations in Dimensions

7.1 Dimensional tolerances on titanium and titanium alloy material covered by this specification shall be as specified in Tables 1-6 and Tables 10-16, as applicable.

## 8. Finish

8.1 Titanium and titanium alloy sheet, strip, and plate shall be free of injurious external and internal imperfections of a nature that will interfere with the purpose for which it is intended. Annealed material may be furnished as descaled, as sandblasted, or as ground, or both sandblasted and ground. If shipped as descaled, sandblasted, or ground, the manufacturer shall be permitted to remove minor surface imperfections by spot grinding if such grinding does not reduce the thickness of the material below the minimum permitted by the tolerance for the thickness ordered.

## 9. Sampling for Chemical Analysis

9.1 Samples for chemical analysis shall be representative of the material being tested. The utmost care must be used in sampling titanium for chemical analysis because of its great affinity for elements such as oxygen, nitrogen, and hydrogen. Therefore, in cutting samples for analysis, the operation should be carried out insofar as possible in a dust-free atmosphere. Chips should be collected from clean metal and tools should be clean and sharp. Samples for analysis should be stored in suitable containers.

## 10. Methods of Chemical Analysis

10.1 The chemical analysis shall normally be conducted using the ASTM standard test methods referenced in 2.1. Other industry standard methods may be used where the ASTM test methods in 2.1 do not adequately cover the elements in the material or by agreement between the producer and purchaser. Alternate techniques are discussed in Guide E2626.

## 11. Retests

11.1 If the results of any chemical or mechanical property test lot are not in conformance with the requirements of this

specification, the lot may be retested at the option of the manufacturer. The frequency of the retest will double the initial number of tests. If the results of the retest conform to the specification, then the retest values will become the test values for certification. Only original conforming test results or the conforming retest results shall be reported to the purchaser. If the results for the retest fail to conform to the specification, the material will be rejected in accordance with Section 14.

## 12. Referee Test and Analysis

12.1 In the event of disagreement between the manufacturer and the purchaser on the conformance of the material to the requirements of this specification, a mutually acceptable referee shall perform the tests in question using the ASTM standard methods in 2.1. The referee's testing shall be used in determining conformance of the material to this specification.

## 13. Rounding-Off Procedure

13.1 For purposes of determining conformance with this specification, an observed or a calculated value shall be rounded off to the nearest "unit" in the last right-hand significant digit used in expressing the limiting value. This is in accordance with the round-off method of Practice E29.

## 14. Rejection

14.1 Material not conforming to the specification or to authorized modifications shall be subject to rejection. Unless otherwise specified, rejected material may be returned to the manufacturer at the manufacturer's expense, unless the purchaser receives, within three weeks of notice of rejection, other instructions for disposition.

## 15. Certification

15.1 The manufacturer shall supply at least one copy of the report certifying that the material supplied has been manufactured, inspected, sampled, and tested in accordance with the requirements of this specification and that the results of chemical analysis, tensile, and other tests meet the requirements of this specification for the grade specified. The report shall include results of all chemical analysis, tensile tests, and all other tests required by the specification.

TABLE 7 Tensile Requirements<sup>A</sup>

Grade	Tensile Strength, min		Yield Strength, 0.2 % Offset				Elongation in 2 in. or 50 mm, min, %	Bend Test (Radius of Mandrel) <sup>B</sup>	
	ksi	MPa	min		max			Under 0.070 in. (1.8 mm) in Thickness	0.070 to 0.187 in. (1.8–4.75 mm) in Thickness
			ksi	MPa	ksi	MPa			
1	35	240	20	138	45	310	24	1.5T	2T
2	50	345	40	275	65	450	20	2T	2.5T
2H <sup>C,D</sup>	58	400	40	275	65	450	20	2T	2.5T
3	65	450	55	380	80	550	18	2T	2.5T
4	80	550	70	483	95	655	15	2.5T	3T
5	130	895	120	828	...	...	10 <sup>E</sup>	4.5T	5T
6	120	828	115	793	...	...	10 <sup>E</sup>	4T	4.5T
7	50	345	40	275	65	450	20	2T	2.5T
7H <sup>C,D</sup>	58	400	40	275	65	450	20	2T	2.5T
9	90	620	70	483	...	...	15 <sup>F</sup>	2.5T	3T
11	35	240	20	138	45	310	24	1.5T	2T
12	70	483	50	345	...	...	18	2T	2.5T
13	40	275	25	170	...	...	24	1.5T	2T
14	60	410	40	275	...	...	20	2T	2.5T
15	70	483	55	380	...	...	18	2T	2.5T
16	50	345	40	275	65	450	20	2T	2.5T
16H <sup>C,D</sup>	58	400	40	275	65	450	20	2T	2.5T
17	35	240	20	138	45	310	24	1.5T	2T
18	90	620	70	483	...	...	15 <sup>F</sup>	2.5T	3T
19 <sup>G,H</sup>	115	793	110	759	...	...	15	3T	3T
20 <sup>G,H</sup>	115	793	110	759	...	...	15	3T	3T
21 <sup>G,H</sup>	115	793	110	759	...	...	15	3T	3T
23	120	828	110	759	...	...	10	4.5T	5T
24	130	895	120	828	...	...	10	4.5T	5T
25	130	895	120	828	...	...	10	4.5T	5T
26	50	345	40	275	65	450	20	2T	2.5T
26H <sup>C,D</sup>	58	400	40	275	65	450	20	2T	2.5T
27	35	240	20	138	45	310	24	1.5T	2T
28	90	620	70	483	...	...	15	2.5T	3T
29	120	828	110	759	...	...	10	4.5T	5T
30	50	345	40	275	65	450	20	2T	2.5T
31	65	450	55	380	80	550	18	2T	2.5T
32	100	689	85	586	...	...	10 <sup>F</sup>	3.5T	4.5T
33	50	345	40	275	65	450	20	2T	2.5T
34	65	450	55	380	80	550	18	2T	2.5T
35	130	895	120	828	...	...	5	8T	8T
36	65	450	60	410	95	655	10	4.5T	5T
37	50	345	31	215	65	450	20	2T	2.5T
38	130	895	115	793	...	...	10	4T	4.5T
39	75	515	60	410	90	620	20	2T	2.5T
40	95	655	75	517	...	...	15	2.5T	3T

<sup>A</sup> Minimum and maximum limits apply to tests taken both longitudinal and transverse to the direction of rolling.  
<sup>B</sup> Bend to Radius of Mandrel, T equals the thickness of the bend test specimen. Bend tests are not applicable to material over 0.187 in. (4.75 mm) in thickness.  
<sup>C</sup> Material is identical to the corresponding numeric grade (that is, Grade 2H = Grade 2) except for the higher guaranteed minimum UTS, and may always be certified as meeting the requirements of its corresponding numeric grade. Grade 2H, 7H, 16H, and 26H are intended primarily for pressure vessel use.  
<sup>D</sup> The H grades were added in response to a user association request based on its study of over 5200 commercial Grade 2, 7, 16, and 26 test reports, where over 99 % met the 58 ksi minimum UTS.  
<sup>E</sup> For Grades 5, 6 and 32 the elongation on materials under 0.025 in. (0.635 mm) in thickness may be obtained only by negotiation.  
<sup>F</sup> Elongation for continuous rolled and annealed (strip product from coil) for Grade 9 and Grade 18 shall be 12 % minimum in the longitudinal direction and 8 % minimum in the transverse direction.  
<sup>G</sup> Properties for material in the solution treated condition.  
<sup>H</sup> Material is normally purchased in the solution treated condition. Therefore, properties for aged material shall be negotiated between manufacturer and purchaser.

16. Marking and Packaging

16.1 Marking

16.1.1 Identification—Unless otherwise specified in the purchase order, each plate, sheet, and strip shall be marked in the respective location indicated below, with the number of this specification, heat number, manufacturer’s identification, and the nominal thickness in inches. The characters shall be not less than ¼ in. (6.35 mm) in height, shall be applied using a suitable marking fluid, and shall be capable of being removed with a hot alkaline cleaning solution without rubbing. The markings shall have no deleterious effect on the material or its

performance. The characters shall be sufficiently stable to withstand ordinary handling.

16.1.2 Plate, flat sheet, and flat strip over 6 in. (152 mm) in width shall be marked in lengthwise rows of characters recurring at intervals not greater than 3 in. (76 mm), the rows being spaced not more than 2 in. (51 mm) apart and alternately staggered. Heat numbers shall occur at least 3 times across the width of the sheet and at intervals not greater than 2 ft (0.610 m) along the length. As an option, when specified in the purchase order, each plate, sheet, or cut length strip may be marked in at least one location with the number of this

TABLE 8 Chemical Requirements

Composition, Weight Percent<sup>A,B,C,D,E</sup>

Grade	UNS Number	Carbon, max.	Oxygen range or max.	Nitrogen, max.	Hydrogen, max.	Iron range or max.	Aluminum	Vanadium	Palladium	Ruthenium	Nickel	Molybdenum	Chromium	Cobalt	Zirconium	Niobium	Tin	Silicon	Other Elements, max. each	Other Elements, max. total
1	R50250	0.08	0.18	0.03	0.015	0.20	--	--	--	--	--	--	--	--	--	--	--	--	0.1	0.4
2/2H	R50400	0.08	0.25	0.03	0.015	0.30	--	--	--	--	--	--	--	--	--	--	--	--	0.1	0.4
3	R50550	0.08	0.35	0.05	0.015	0.30	--	--	--	--	--	--	--	--	--	--	--	--	0.1	0.4
4	R50700	0.08	0.40	0.05	0.015	0.50	--	--	--	--	--	--	--	--	--	--	--	--	0.1	0.4
5	R56400	0.08	0.20	0.05	0.015	0.40	5.5-6.75	3.5-4.5	--	--	--	--	--	--	--	--	--	--	0.1	0.4
6	R54520	0.08	0.20	0.03	0.015	0.50	4.0-6.0	--	--	--	--	--	--	--	--	--	2.0-3.0	--	0.1	0.4
7/7H	R52400	0.08	0.25	0.03	0.015	0.30	--	--	0.12-0.25	--	--	--	--	--	--	--	--	--	0.1	0.4
9	R56320	0.08	0.15	0.03	0.015	0.25	2.5-3.5	2.0-3.0	--	--	--	--	--	--	--	--	--	--	0.1	0.4
11	R52250	0.08	0.18	0.03	0.015	0.20	--	--	0.12-0.25	--	--	--	--	--	--	--	--	--	0.1	0.4
12	R53400	0.08	0.25	0.03	0.015	0.30	--	--	--	0.6-0.9	0.2-0.4	--	--	--	--	--	--	--	0.1	0.4
13	R53413	0.08	0.10	0.03	0.015	0.20	--	--	--	0.04-0.06	0.4-0.6	--	--	--	--	--	--	--	0.1	0.4
14	R53414	0.08	0.15	0.03	0.015	0.30	--	--	--	0.04-0.06	0.4-0.6	--	--	--	--	--	--	--	0.1	0.4
15	R53415	0.08	0.25	0.05	0.015	0.30	--	--	--	0.04-0.06	0.4-0.6	--	--	--	--	--	--	--	0.1	0.4
16/16H	R52402	0.08	0.25	0.03	0.015	0.30	--	--	0.04-0.08	--	--	--	--	--	--	--	--	--	0.1	0.4
17	R52252	0.08	0.18	0.03	0.015	0.20	--	--	0.04-0.08	--	--	--	--	--	--	--	--	--	0.1	0.4
18	R56322	0.08	0.15	0.03	0.015	0.25	2.5-3.5	2.0-3.0	0.04-0.08	--	--	--	--	--	--	--	--	--	0.1	0.4
19	R58640	0.05	0.12	0.03	0.02	0.30	3.0-4.0	7.5-8.5	--	--	--	3.5-4.5	5.5-6.5	--	3.5-4.5	--	--	--	0.15	0.4
20	R58645	0.05	0.12	0.03	0.02	0.30	3.0-4.0	7.5-8.5	0.04-0.08	--	--	3.5-4.5	5.5-6.5	--	3.5-4.5	--	--	--	0.15	0.4
21	R58210	0.05	0.17	0.03	0.015	0.40	2.5-3.5	--	--	--	--	14.0-16.0	2.0-3.0	--	--	2.2-3.2	--	0.15-0.25	0.1	0.4
23	R56407	0.08	0.13	0.03	0.0125	0.25	5.5-6.5	3.5-4.5	--	--	--	--	--	--	--	--	--	--	0.1	0.4
24	R56405	0.08	0.20	0.05	0.015	0.40	5.5-6.75	3.5-4.5	0.04-0.08	--	--	--	--	--	--	--	--	--	0.1	0.4
25	R56403	0.08	0.20	0.05	0.015	0.40	5.5-6.75	3.5-4.5	0.04-0.08	--	0.3-0.8	--	--	--	--	--	--	--	0.1	0.4
26/26H	R52404	0.08	0.25	0.03	0.015	0.30	--	--	--	0.08-0.14	--	--	--	--	--	--	--	--	0.1	0.4
27	R52254	0.08	0.18	0.03	0.015	0.20	--	--	--	0.08-0.14	--	--	--	--	--	--	--	--	0.1	0.4
28	R56323	0.08	0.15	0.03	0.015	0.25	2.5-3.5	2.0-3.0	--	0.08-0.14	--	--	--	--	--	--	--	--	0.1	0.4
29	R56404	0.08	0.13	0.03	0.0125	0.25	5.5-6.5	3.5-4.5	--	0.08-0.14	--	--	--	--	--	--	--	--	0.1	0.4
30	R53530	0.08	0.25	0.03	0.015	0.30	--	--	0.04-0.08	--	--	--	--	0.20-0.80	--	--	--	--	0.1	0.4
31	R53532	0.08	0.35	0.05	0.015	0.30	--	--	0.04-0.08	--	--	--	--	0.20-0.80	--	--	--	--	0.1	0.4

471

ASME NORMDOC.COM. Click to view the full PDF of ASME BPVC.II.B (ASME BPVC Section II part B) 2025

TABLE 8 Continued

Composition, Weight Percent<sup>A,B,C,D,E</sup>

Grade	UNS Number	Carbon, max.	Oxygen range or max.	Nitrogen, max.	Hydrogen, max.	Iron range or max.	Aluminum	Vanadium	Palladium	Ruthenium	Nickel	Molybdenum	Chromium	Cobalt	Zirconium	Niobium	Tin	Silicon	Other Elements, max. each	Other Elements, max. total
32	R55111	0.08	0.11	0.03	0.015	0.25	4.5-5.5	0.6-1.4	--	--	--	0.6-1.2	--	--	0.6-1.4	--	0.6-1.4	0.06-0.14	0.1	0.4
33	R53442	0.08	0.25	0.03	0.015	0.30	--	--	0.01-0.02	0.02-0.04	0.35-0.55	--	0.1-0.2	--	--	--	--	--	0.1	0.4
34	R53445	0.08	0.35	0.05	0.015	0.30	--	--	0.01-0.02	0.02-0.04	0.35-0.55	--	0.1-0.2	--	--	--	--	--	0.1	0.4
35	R56340	0.08	0.25	0.05	0.015	0.20-0.80	4.0-5.0	1.1-2.1	--	--	--	1.5-2.5	--	--	--	--	--	0.20-0.40	0.1	0.4
36	R58450	0.04	0.16	0.03	0.015	0.03	--	--	--	--	--	--	--	--	--	42.0-47.0	--	--	0.1	0.4
37	R52815	0.08	0.25	0.03	0.015	0.30	1.0-2.0	--	--	--	--	--	--	--	--	--	--	--	0.1	0.4
38	R54250	0.08	0.20-0.30	0.03	0.015	1.2-1.8	3.5-4.5	2.0-3.0	--	--	--	--	--	--	--	--	--	--	0.1	0.4
39	R53390	0.08	0.15	0.03	0.015	0.15-0.40	--	--	--	--	--	--	--	--	--	--	--	0.30-0.50	0.1	0.4
40	R54407	0.08	0.10-0.20	0.05	0.015	0.10-0.40	0.40-1.30	3.0-4.8	--	--	--	--	--	--	--	--	--	0.15-0.35	0.1	0.4

<sup>A</sup> At minimum, the analysis of samples from the top and bottom of the ingot shall be completed and reported for all elements (Except Hydrogen – See Footnote B) listed for the respective grade in this table.  
<sup>B</sup> At a minimum, one final product hydrogen samples shall be tested and reported. Ingot hydrogen need not be reported. Lower hydrogen may be obtained by negotiation with the manufacturer.  
<sup>C</sup> Single values are maximum. The percentage of titanium is determined by difference.  
<sup>D</sup> Other elements need not be reported unless the concentration level is greater than 0.1 % each, or 0.4 % total. Other elements may not be added intentionally. Other elements may be present in titanium or titanium alloys in small quantities and are inherent to the manufacturing process. In titanium these elements typically include aluminum, vanadium, tin, chromium, molybdenum, niobium, zirconium, hafnium, bismuth, ruthenium, palladium, yttrium, copper, silicon, cobalt, tantalum, nickel, boron, manganese, and tungsten.  
<sup>E</sup> The purchaser may, in the written purchase order, request analysis for specific elements not listed in this specification.

ASME NORMDOC.COM : Click to view the full PDF of ASME BPVC.II.B (ASME BPVC Section II part B) 2025

**TABLE 9 Permissible Variations in Product Analysis**

Element	Product Analysis Limits, max or Range, %	Permissible Variation in Product Analysis
Aluminum	0.4 to 2.5	±0.20
Aluminum	2.5 to 6.75	±0.40
Carbon	0.10	+0.02
Chromium	0.1 to 0.2	±0.02
Chromium	5.5 to 6.5	±0.30
Cobalt	0.2 to 0.8	±0.05
Hydrogen	0.02	+0.002
Iron	0.80	+0.15
Iron	1.2 to 1.8	±0.20
Molybdenum	0.2 to 0.4	±0.03
Molybdenum	0.6 to 1.2	±0.15
Molybdenum	1.5 to 4.5	±0.20
Molybdenum	14.0 to 16.0	±0.50
Nickel	0.3 to 0.9	±0.05
Niobium	2.2 to 3.2	±0.15
Niobium	>30	±0.50
Nitrogen	0.05	+0.02
Oxygen	0.30	+0.03
Oxygen	0.31 to 0.40	±0.04
Palladium	0.01 to 0.02	±0.002
Palladium	0.04 to 0.08	±0.005
Palladium	0.12 to 0.25	±0.02
Ruthenium	0.02 to 0.04	±0.005
Ruthenium	0.04 to 0.06	±0.005
Ruthenium	0.08 to 0.14	±0.01
Silicon	0.06 to 0.50	±0.02
Tin	0.6 to 3.0	±0.15
Vanadium	0.6 to 4.8	±0.15
Vanadium	7.5 to 8.5	±0.40
Zirconium	0.6 to 1.4	±0.15
Residuals <sup>4</sup> (each)	0.15	+0.02

<sup>4</sup> A residual is an element present in a metal or alloy in small quantities and is inherent to the manufacturing process but not added intentionally. In titanium these elements include aluminum, vanadium, tin, iron, chromium, molybdenum, niobium, zirconium, hafnium, bismuth, ruthenium, palladium, yttrium, copper, silicon, cobalt, tantalum, nickel, boron, manganese and tungsten.

specification, heat number, manufacturer's identification, and the nominal thickness in inches or millimetres as required.

16.1.3 Flat strip 6 in. (152 mm) and under in width shall be marked near one end.

16.1.4 Coiled sheet and strip shall be marked near the outside end of the coil.

16.2 *Packaging*—Unless otherwise specified, material purchased under this specification may be packaged for shipment either by boxing, crating, single boarding, burlapping, or with no protection in accordance with the manufacturer's standard practice.

## 17. Keywords

17.1 plate; sheet; strip; titanium; titanium alloys

**TABLE 10 Permissible Variations in Width<sup>A</sup> of Titanium Strip**

Specified Thickness, in. (mm)	Permissible Variations from Specified Width, plus and minus, for Widths Given, in. (mm)					
	Under 1/2 to 3/16 (12.70 to 4.76), incl	1/2 to 6 (12.70 to 152.40), incl	Over 6 to 9 (152.40 to 228.60), incl	Over 9 to 12 (228.60 to 304.80), incl	Over 12 to 20 (304.80 to 508.0), incl	Over 20 to 24 (508.0 to 609.6), excl
Under 3/16 to 0.161 (4.76 to 4.09), incl	...	0.016 (0.41)	0.020 (0.51)	0.020 (0.51)	0.031 (0.79)	0.031 (0.79)
0.160 to 0.100 (4.06 to 2.54), incl	0.010 (0.25)	0.010 (0.25)	0.016 (0.41)	0.016 (0.41)	0.020 (0.51)	0.020 (0.51)
0.099 to 0.069 (2.51 to 1.75), incl	0.008 (0.20)	0.008 (0.20)	0.010 (0.25)	0.010 (0.25)	0.016 (0.41)	0.020 (0.51)
0.068 (1.73) and under	0.005 (0.13)	0.005 (0.13)	0.005 (0.13)	0.010 (0.25)	0.016 (0.41)	0.020 (0.51)

<sup>A</sup> These tolerances are applicable for a standard No. 3 edge.

**TABLE 11 Permissible Variations in Length of Titanium Strip**

Specified Length, ft (m)	Permissible Variations in Length, in. (mm)
To 5 (1.524), incl	+3/8 (+9.52), -0
Over 5 to 10 (1.524 to 3.048), incl	+1/2 (+12.70), -0
Over 10 to 20 (3.048 to 6.096), incl	+5/8 (+15.88), -0

**TABLE 12 Permissible Variations in Thickness of Titanium Strip<sup>1</sup>**

Specified Thickness, in. (mm)	Permissible Variations from Specified Thickness, plus and minus, for Widths Given, in. (mm)							
	Under 1 to 3/16 (25.4 to 4.76), incl	Under 3 to 1 (76.2 to 25.4), incl	3 to 6 (76.2 to 152.4), incl	Over 6 to 9 (152.4 to 228.6), incl	Over 9 to 12 (228.6 to 304.8), incl	Over 12 to 16 (304.8 to 406.4), incl	Over 16 to 20 (406.4 to 508.0), incl	Over 20 to 24 (508.0 to 609.6), incl
Under 3/16 to 0.161 (4.76 to 4.09), incl	0.002 (0.05)	0.003 (0.08)	0.004 (0.10)	0.004 (0.10)	0.004 (0.10)	0.005 (0.13)	0.006 (0.16)	0.006 (0.16)
0.160 to 0.100 (4.06 to 2.54), incl	0.002 (0.05)	0.002 (0.05)	0.003 (0.08)	0.004 (0.10)	0.004 (0.10)	0.004 (0.10)	0.005 (0.13)	0.005 (0.13)
0.099 to 0.069 (2.51 to 1.75), incl	0.002 (0.05)	0.002 (0.05)	0.003 (0.08)	0.003 (0.08)	0.003 (0.08)	0.004 (0.10)	0.004 (0.10)	0.004 (0.10)
0.068 to 0.050 (1.73 to 1.27), incl	0.002 (0.05)	0.002 (0.05)	0.003 (0.08)	0.003 (0.08)	0.003 (0.08)	0.003 (0.08)	0.004 (0.10)	0.004 (0.10)
0.049 to 0.040 (1.24 to 1.02), incl	0.002 (0.05)	0.002 (0.05)	0.0025 (0.06)	0.003 (0.08)	0.003 (0.08)	0.003 (0.08)	0.004 (0.10)	0.004 (0.10)
0.039 to 0.035 (0.99 to 0.89), incl	0.002 (0.05)	0.002 (0.05)	0.0025 (0.06)	0.003 (0.08)	0.003 (0.08)	0.003 (0.08)	0.003 (0.08)	0.003 (0.08)
0.034 to 0.029 (0.86 to 0.74), incl	0.0015 (0.04)	0.0015 (0.04)	0.002 (0.05)	0.0025 (0.06)	0.0025 (0.06)	0.0025 (0.06)	0.003 (0.08)	0.003 (0.08)
0.028 to 0.026 (0.71 to 0.66), incl	0.001 (0.03)	0.0015 (0.04)	0.0015 (0.04)	0.002 (0.05)	0.002 (0.05)	0.002 (0.05)	0.0025 (0.06)	0.003 (0.08)
0.025 to 0.020 (0.64 to 0.51), incl	0.001 (0.03)	0.001 (0.03)	0.0015 (0.04)	0.002 (0.05)	0.002 (0.05)	0.002 (0.05)	0.0025 (0.06)	0.0025 (0.06)
0.019 to 0.017 (0.48 to 0.43), incl	0.001 (0.03)	0.001 (0.03)	0.001 (0.03)	0.0015 (0.04)	0.0015 (0.04)	0.002 (0.05)	0.002 (0.05)	0.002 (0.05)
0.016 to 0.013 (0.41 to 0.33), incl	0.001 (0.03)	0.001 (0.03)	0.001 (0.03)	0.0015 (0.04)	0.0015 (0.04)	0.0015 (0.04)	0.002 (0.05)	0.002 (0.05)
0.012 (0.30)	0.001 (0.03)	0.001 (0.03)	0.001 (0.03)	0.001 (0.03)	0.001 (0.03)	0.0015 (0.04)	0.0015 (0.04)	0.0015 (0.04)
0.011 (0.28)	0.001 (0.03)	0.001 (0.03)	0.001 (0.03)	0.001 (0.03)	0.001 (0.03)	0.0015 (0.04)	0.0015 (0.04)	0.0015 (0.04)
0.010 <sup>B</sup> (0.25)	0.001 (0.03)	0.001 (0.03)	0.001 (0.03)	0.001 (0.03)	0.001 (0.03)	0.001 (0.03)	0.0015 (0.04)	0.0015 (0.04)

<sup>A</sup> Thickness measurements are taken 3/8 in. (9.5 mm) from the edge of the strip, except that on widths less than 1 in. (25.4 mm) the tolerances given are applicable for measurements at all locations.

<sup>B</sup> For thicknesses under 0.010 in. (0.25 mm), in widths to 16 in. (406 mm) a tolerance of ±10 % of the thickness shall apply. In widths over 16 to 23 1/16 in. (406 to 608 mm), incl, a tolerance of ±15 % of the thickness shall apply.

**TABLE 13 Permissible Variations in Weight of Titanium Strip**

The actual shipping weight of any one item of an ordered thickness and width in any finish may exceed estimated weight by as much as 10 %.

**TABLE 14 Permissible Variations in Width and Length<sup>A</sup> of Titanium Plate, Rectangular, Sheared**

Specified Length, in. (mm)	Specified Width, in. (mm)	Permissible Variations Over Specified Dimension for Thicknesses Given, in. (mm)					
		Under 3/8 (9.52)		3/8 to 5/8 (9.52 to 15.88), excl		5/8 (15.88) and over	
		Width	Length	Width	Length	Width	Length
Under 120 (3048)	Under 60 (1524)	3/8 (9.52)	1/2 (12.70)	7/16 (11.11)	5/8 (15.88)	1/2 (12.70)	3/4 (19.05)
	60 to 84 (1524 to 2134), excl	7/16 (11.11)	5/8 (15.88)	1/2 (12.70)	11/16 (17.46)	5/8 (15.88)	7/8 (22.22)
	84 to 108 (2134 to 2743), excl	1/2 (12.70)	3/4 (19.05)	5/8 (15.88)	7/8 (22.22)	3/4 (19.05)	1 (25.40)
	108 (2743) or over	5/8 (15.88)	7/8 (22.22)	3/4 (19.05)	1 (25.40)	7/8 (22.22)	1 1/8 (28.58)
120 to 240 (3048 to 6096), excl	Under 60 (1524)	3/8 (9.52)	1/2 (12.70)	7/16 (11.11)	5/8 (15.88)	1/2 (12.70)	3/4 (19.05)
	60 to 84 (1524 to 2134), excl	7/16 (11.11)	5/8 (15.88)	1/2 (12.70)	11/16 (17.46)	5/8 (15.88)	7/8 (22.22)
	84 to 108 (2134 to 2743), excl	1/2 (12.70)	3/4 (19.05)	5/8 (15.88)	7/8 (22.22)	3/4 (19.05)	1 (25.40)
	108 (2743) or over	5/8 (15.88)	7/8 (22.22)	3/4 (19.05)	1 (25.40)	7/8 (22.22)	1 1/8 (28.58)
240 to 360 (6096 to 9144), excl	Under 60 (1524)	3/8 (9.52)	1 (25.40)	1/2 (12.70)	1 1/8 (28.58)	5/8 (15.88)	1 1/4 (31.75)
	60 to 84 (1524 to 2134), excl	7/16 (11.11)	1 (25.40)	5/8 (15.88)	1 1/8 (28.58)	3/4 (19.05)	1 1/4 (31.75)
	84 to 108 (2134 to 2743), excl	1/2 (12.70)	1 (25.40)	5/8 (15.88)	1 1/8 (28.58)	3/4 (19.05)	1 1/4 (31.75)
	108 (2743) or over	5/8 (15.88)	1 (25.40)	5/8 (15.88)	1 1/8 (28.58)	3/4 (19.05)	1 1/4 (31.75)
360 to 480 (9144 to 12192), excl	Under 60 (1524)	3/8 (9.52)	1 1/8 (28.58)	7/8 (22.22)	1 1/4 (31.75)	1 (25.40)	1 3/8 (34.92)
	60 to 84 (1524 to 2134), excl	7/16 (11.11)	1 1/8 (28.58)	7/8 (22.22)	1 1/4 (31.75)	5/8 (15.88)	1 1/2 (38.10)
	84 to 108 (2134 to 2743), excl	1/2 (12.70)	1 1/4 (31.75)	5/8 (15.88)	1 3/8 (34.92)	3/4 (19.05)	1 1/2 (38.10)
	108 (2743) or over	5/8 (15.88)	1 1/4 (31.75)	3/4 (19.05)	1 3/8 (34.92)	3/4 (19.05)	1 1/2 (38.10)
480 to 600 (12192 to 15240), excl	Under 60 (1524)	3/8 (9.52)	1 1/4 (31.75)	7/8 (22.22)	1 1/2 (38.10)	1 (25.40)	1 3/8 (34.92)
	60 to 84 (1524 to 2134), excl	7/16 (11.11)	1 1/4 (31.75)	5/8 (15.88)	1 1/2 (38.10)	3/4 (19.05)	1 3/8 (34.92)
	84 to 108 (2134 to 2743), excl	1/2 (12.70)	1 3/8 (34.92)	3/4 (19.05)	1 1/2 (38.10)	7/8 (22.22)	1 3/8 (34.92)
	108 (2743) or over	5/8 (15.88)	1 3/8 (34.92)	3/4 (19.05)	1 1/2 (38.10)	7/8 (22.22)	1 3/8 (34.92)
600 (15 240) or over	Under 60 (1524)	3/8 (9.52)	1 1/2 (38.10)	7/8 (22.22)	1 3/4 (41.28)	1 (25.40)	1 3/4 (41.28)
	60 to 84 (1524 to 2134), excl	7/16 (11.11)	1 1/2 (38.10)	5/8 (15.88)	1 3/4 (41.28)	3/4 (19.05)	1 3/4 (41.28)
	84 to 108 (2134 to 2743), excl	1/2 (12.70)	1 3/4 (41.28)	3/4 (19.05)	1 3/4 (41.28)	7/8 (22.22)	1 3/4 (41.28)
	108 (2743) or over	5/8 (15.88)	1 3/4 (41.28)	3/4 (19.05)	1 3/4 (41.28)	7/8 (22.22)	1 3/4 (41.28)

<sup>A</sup> The tolerance under the specified width and length is 1/4 in. (6.35 mm).

**TABLE 15 Permissible Variations from a Flat Surface for Titanium Plate, Annealed**

Specified Thickness, in. (mm)	Permissible Variations from a Flat Surface for Width or Length Given, in. (mm)								
	48 (1219) or Under	48, excl to 60 (1219 to 1524), excl	60 to 72 (1524 to 1829), excl	72 to 84 (1829 to 2134), excl	84 to 96 (2134 to 2438), excl	96 to 108 (2438 to 2743), excl	108 to 120 (2743 to 3048), excl	120 to 144 (3048 to 3658), excl	144 (3658) and Over
3/16 to 1/4 (4.76 to 6.35), excl	3/4 (19.05)	1 1/16 (26.99)	1 1/4 (31.75)	1 3/8 (34.92)	1 5/8 (41.28)	1 5/8 (41.28)	1 7/8 (47.62)	2 (50.8)	2 1/4 (57.15)
1/4 to 3/8 (6.35 to 9.54), excl	1 1/16 (17.46)	3/4 (19.05)	1 5/16 (23.81)	1 1/8 (28.58)	1 3/8 (34.92)	1 7/16 (36.51)	1 9/16 (39.69)	1 7/8 (47.62)	2 1/8 (53.98)
3/8 to 1/2 (9.54 to 12.70), excl	1/2 (12.70)	5/8 (15.88)	1 1/16 (17.46)	3/4 (19.05)	1 5/16 (23.81)	1 1/8 (28.58)	1 1/4 (31.75)	1 7/16 (36.51)	1 3/4 (44.45)
1/2 to 3/4 (12.70 to 19.05), excl	1/2 (12.70)	5/8 (15.88)	5/8 (15.88)	5/8 (15.88)	1 3/16 (20.64)	1 1/8 (28.58)	1 1/8 (28.58)	1 1/8 (28.58)	1 3/8 (34.92)
3/4 to 1 (19.05 to 25.40), excl	1/2 (12.70)	5/8 (15.88)	5/8 (15.88)	5/8 (15.88)	3/4 (19.05)	1 3/16 (20.64)	1 5/16 (23.81)	1 (25.40)	1 1/8 (28.58)
1 to 1 1/2 (25.40 to 38.10), excl	1/2 (12.70)	5/8 (15.88)	5/8 (15.88)	5/8 (15.88)	1 1/16 (17.46)	1 1/16 (17.46)	1 1/16 (17.46)	3/4 (19.05)	1 (25.40)
Over 1 1/2 to 4 (38.10 to 101.6), excl	3/16 (4.76)	5/16 (7.94)	3/8 (9.54)	7/16 (11.11)	1/2 (12.70)	5/16 (14.29)	5/8 (15.88)	3/4 (19.05)	7/8 (22.22)
Over 4 to 6 (101.6 to 152.4), excl	1/4 (6.35)	3/8 (9.54)	1/2 (12.70)	5/16 (14.29)	5/8 (15.88)	3/4 (19.05)	7/8 (22.22)	1 (25.40)	1 1/8 (28.58)

Note 1—Variations in flatness apply to plates up to 15 ft (4.57 m) in length, or to any 15 ft of longer plates.

Note 2—If the longer dimension is under 36 in. (914 mm) the variation is not greater than 1/4 in. (6.35 mm).

Note 3—The shorter dimension specified is considered the width and the variation in flatness across the width does not exceed the tabular amount for that dimension.

Note 4—The maximum deviation from a flat surface does not customarily exceed the tabular tolerance for the longer dimension specified.

TABLE 16 Permissible Variations in Thickness for Titanium Plate

Specified Thickness, in. (mm)	Width, in. (mm) <sup>A</sup>			
	To 84 (2134), incl	Over 84 (2134) to 120 (3048), incl	Over 120 (3048) to 144 (3658), incl	Over 144 (3658)
	Tolerances Over Specified Thickness, in. (mm) <sup>B</sup>			
0.1875 (4.76) to 0.375 (9.52), excl	0.045 (1.14)	0.050 (1.27)	0.065 (1.65)	...
0.375 (9.52) to 0.750 (19.05), excl	0.055 (1.40)	0.060 (1.52)	0.075 (1.90)	0.090 (2.29)
0.750 (19.05) to 1.000 (25.40), excl	0.060 (1.52)	0.065 (1.65)	0.085 (2.16)	0.100 (2.54)
1.000 (25.40) to 2.000 (50.80), excl	0.070 (1.78)	0.075 (1.90)	0.095 (2.41)	0.115 (2.92)
2.000 (50.80) to 3.000 (76.20), excl	0.125 (3.18)	0.150 (3.81)	0.175 (4.44)	0.200 (5.08)
3.000 (76.20) to 4.000 (101.6), excl	0.175 (4.44)	0.210 (5.33)	0.245 (6.22)	0.280 (7.11)
4.000 (101.6) to 6.000 (152.4), excl	0.250 (6.35)	0.300 (7.62)	0.350 (8.89)	0.400 (10.16)
6.000 (152.4) to 8.000 (203.2), excl	0.350 (8.89)	0.420 (10.67)	0.490 (12.45)	0.560 (14.22)
8.000 (203.2) to 10.000 (254.0), incl	0.450 (11.43)	0.540 (13.72)	0.630 (16.00)	...

<sup>A</sup> Thickness is measured along the longitudinal edges of the plate at least  $\frac{3}{8}$  in. (9.52 mm), but not more than 3 in. (76.20 mm), from the edge.

<sup>B</sup> For circles, the over thickness tolerances in this table apply to the diameter of the circle corresponding to the width ranges shown. For plates of irregular shape, the over thickness tolerances apply to the greatest width corresponding to the width ranges shown. For plates up to 10 in. (254.0 mm) incl. in thickness, the tolerance under the specified thickness is 0.010 in. (0.25 mm).

## SUPPLEMENTARY REQUIREMENTS

These requirements shall apply only when specified in the purchase order, in which event the specified tests shall be made by the manufacturer before shipment of the plates.

### S1. Surface Requirement Bend Tests

S1.1 The purpose of this test is to measure the cleanliness or ductility, or both, of the metal surface. Specimens shall be taken from sheet or plate material produced from the same ingot or bloom materials, processed the same way to the same nominal thickness, width and length, produced in one production run or campaign, finished in the same way, and otherwise representative of the material supplied.

S1.2 Four guided- or free-bend tests of sheet or plate material limited to the grades listed in S1.4. Two bends shall be made in the L direction and two in the T direction. Each pair of these bends will place opposite surfaces of the sheet or plate material in tension.

S1.3 The bends are to be made in accordance with Test Method E290, using Method 1, Guided Bend Test described in paragraph 3.6, bent through 180°, and allowed to spring back naturally. The bend specimen may be of less than full material thickness; however, the outer surface of the specimen must include the original material surface with no material removal or surface conditioning other than at the rounded corners, and must otherwise be representative of the product as supplied. The width of the bend test specimen shall be at least 5 times the thickness.

S1.4 The bend radius will be such to provide minimum elongation of the outer fibers of the bent specimen at 180° bend as follows:

Applicable Grades	Minimum Elongation	Bend Radius
1, 11, 13, 17, 27	24 %	1.6 × T
2, 2H, 7, 7H, 14, 16, 16H, 26, 26H, 30, 33, 37, 39	20 %	2.0 × T
3, 12, 15, 31, 34	18 %	2.3 × T
4, 9, 18, 19, 20, 28, 40	15 %	2.8 × T
5, 6, 21, 23, 24, 25, 29, 32, 36, 38	10 %	4.5 × T
35	5 %	10 × T

S1.5 Criteria for acceptance will be the absence of any cracking or surface separations not originating at the edge of specimen viewed with the unaided eye.

S1.6 The results of the test shall be reported as required by paragraph 10 of Test Method E290.

### S2. Alternate Yield Strength Maximum

S2.1 Maximum yield strength (0.2 % Offset) of Grade 1, 11, 17, or 27 shall be limited to 40 ksi (275 MPa).

### S3. Special Flatness Requirements

S3.1 These requirements apply only for material to be used for explosive cladding.

S3.2 These requirements apply only to Grades 1, 11, 17, and 27 and only in thickness ranging from 0.078 to 0.78 in. (2.0 to 20 mm), inclusive.

S3.3 The overall out-of-flatness shall be no greater than 50 % of that permitted in Table 15.

S3.4 Localized out-of-flatness shall be no greater than 0.12 in. (3.0 mm) deviation from a 39 in. (1000 mm) long straight edge when placed at any location on the plate surface. When

the straight edge is placed on a single high point, the maximum deviation from the plate at each end shall be no greater than 0.12 in. (3.0 mm).

ASMENORMDOC.COM : Click to view the full PDF of ASME BPVC.II.B (ASME BPVC Section II part B) 2025

ASMENORMDOC.COM : Click to view the full PDF of ASME BPVC.II.B (ASME BPVC Section II part B) 2025

INTENTIONALLY LEFT BLANK

## SPECIFICATION FOR COPPER-BASE ALLOY CENTRIFUGAL CASTINGS



**SB-271/SB-271M**



(25)

(Identical with ASTM Specification B271/B271M-18 except that certification and foundry test reports have been made mandatory.)

*ASME SB-271/SB-271M replaces paras. 4.2.3, 4.2.4, and 9.1 of ASTM B271/B271M with the following:*

4.2.3 DELETED

4.2.4 DELETED

9.1 Castings shall comply with the following:



Designation: B271/B271M – 18

## Standard Specification for Copper-Base Alloy Centrifugal Castings<sup>1</sup>

This standard is issued under the fixed designation B271/B271M; the number immediately following the designation indicates the year of original adoption or, in the case of revision, the year of last revision. A number in parentheses indicates the year of last reapproval. A superscript epsilon ( $\epsilon$ ) indicates an editorial change since the last revision or reapproval.

### 1. Scope\*

1.1 This specification establishes requirements for centrifugal castings of copper-base alloys having the nominal compositions shown in Table 1.

1.2 The values stated in either SI units or inch-pound units are to be regarded separately as standard. The values stated in each system may not be exact equivalents; therefore, each system shall be used independently of the other. Combining values from the two systems may result in non-conformance with the standard.

1.3 *This international standard was developed in accordance with internationally recognized principles on standardization established in the Decision on Principles for the Development of International Standards, Guides and Recommendations issued by the World Trade Organization Technical Barriers to Trade (TBT) Committee.*

### 2. Referenced Documents

2.1 The following documents in the current issue of the Book of Standards form a part of this specification to the extent referenced herein:

#### 2.2 ASTM Standards:<sup>2</sup>

B208 Practice for Preparing Tension Test Specimens for Copper Alloy Sand, Permanent Mold, Centrifugal, and Continuous Castings

B824 Specification for General Requirements for Copper Alloy Castings

B846 Terminology for Copper and Copper Alloys

E10 Test Method for Brinell Hardness of Metallic Materials

#### 2.3 ASME Code:<sup>3</sup>

Boiler and Pressure Vessel Code

<sup>1</sup> This specification is under the jurisdiction of ASTM Committee B05 on Copper and Copper Alloys and is the direct responsibility of Subcommittee B05.05 on Castings and Ingots for Remelting.

Current edition approved Oct. 1, 2018. Published October 2018. Originally approved in 1954. Last previous edition approved in 2015 as B271/B271M–15. DOI: 10.1520/B0271\_B0271M-18.

<sup>2</sup> For referenced ASTM standards, visit the ASTM website, [www.astm.org](http://www.astm.org), or contact ASTM Customer Service at [service@astm.org](mailto:service@astm.org). For *Annual Book of ASTM Standards* volume information, refer to the standard's Document Summary page on the ASTM website.

<sup>3</sup> Available from American Society of Mechanical Engineers (ASME), ASME International Headquarters, Two Park Ave., New York, NY 10016-5990, <http://www.asme.org>.

### 3. Terminology

3.1 Definitions of terms relating to copper alloys can be found in Terminology B846.

### 4. Ordering Information

4.1 Orders for centrifugal castings under this specification should include the following information:

4.1.1 Specification title, number, and year of issue;

4.1.2 Quantity (length or number) of castings;

4.1.3 Copper Alloy UNS Number (Table 1) and temper (as-cast, heat-treated, and so forth);

4.1.4 Dimensions or drawing number and condition (as-cast, machined, and so forth);

4.1.5 ASME Boiler and Pressure Vessel Code requirements (Section 9); and

4.1.6 When castings are purchased for agencies of the U.S. Government, the Supplementary Requirements in Specification B824 may be specified.

4.2 The following are optional and should be specified in the purchase order when required:

4.2.1 Pressure test or soundness requirements (Specification B824),

4.2.2 Approval of weld repair (Section 8),

4.2.3 Certification (Specification B824),

4.2.4 Foundry test report (Specification B824),

4.2.5 Witness inspection (Specification B824),

4.2.6 Product marking (Specification B824), and

4.2.7 Castings for seawater service (Section X1.2).

### 5. Materials and Manufacture

5.1 Castings in Copper Alloy UNS No. C95520 are used in the heat-treated condition only.

### 6. Chemical Composition

6.1 The centrifugal castings shall conform to the chemical requirement shown in Table 2 for the Copper Alloy UNS Numbers specified in the purchase order.

6.2 These specification limits do not preclude the presence of other elements. Limits may be established and analysis required for unnamed elements agreed upon between the manufacturer or supplier and the purchaser. Copper or zinc may be given as remainder and may be taken as the difference

TABLE 1 Nominal Compositions

Classification	Copper Alloy UNS No.	Commercial Designation	Copper	Tin	Lead	Zinc	Nickel	Iron	Alum- inum	Mang- anese	Silicon
Leaded red brass	C83600	85-5-5-5	85	5	5	5	...	...	...	...	...
	C83800	83-4-6-7 or commercial red brass	83	4	6	7	...	...	...	...	...
Leaded semi-red brass	C84400	81-3-7-9 or valve composition	81	3	7	9	...	...	...	...	...
	C84800	76-2 $\frac{1}{2}$ -6 $\frac{1}{2}$ -15 or semi-red brass	76	2 $\frac{1}{2}$	6 $\frac{1}{2}$	15	...	...	...	...	...
Leaded yellow brass	C85200	high copper yellow brass	72	1	3	24	...	...	...	...	...
	C85400	commercial No. 1 yellow brass	67	1	3	29	...	...	...	...	...
Yellow brass	C85470 <sup>A</sup>		62.5	2.5	...	34.3	...	...	0.5	...	...
Leaded yellow brass	C85700	leaded naval brass	61	1	1	37	...	...	...	...	...
Manganese bronze	C86100	manganese bronze	67	...	...	...	...	3	5	4	...
High-strength yellow brass	C86200	high-strength manganese bronze	63	...	...	27	...	3	4	3	...
	C86300	high-strength manganese bronze	61	...	...	27	...	3	6	3	...
Silicon bronze and silicon brass	C86400	leaded manganese bronze	58	1	1	38	...	1	$\frac{1}{2}$	$\frac{1}{2}$	...
	C86500	No. 1 manganese bronze	58	...	...	39	...	1	1	1	...
	C86700	leaded manganese bronze	58	1	1	34	...	2	2	2	...
	C87300	silicon bronze	95	...	...	...	...	...	...	1	4
	C87400	silicon brass	82	...	$\frac{1}{2}$	14	...	...	...	...	3 $\frac{1}{2}$
	C87500	silicon brass	82	...	...	14	...	...	...	...	4
Tin bronze and leaded tin bronze	C87600	silicon bronze	89	...	...	6	...	...	...	...	5
	C90300	88-8-0-4, or modified "G" bronze	88	8	...	4	...	...	...	...	...
	C90500	88-10-0-2, or "G" bronze	88	10	...	2	...	...	...	...	...
	C92200	88-6-2-4 or "M" bronze	88	6	2	4	...	...	...	...	...
	C92300	87-8-1-4, or Navy PC	87	8	1	4	...	...	...	...	...
	High-lead tin bronze	C93200	83-7-7-3	83	7	7	3	...	...	...	...
C93500		85-5-9-1	85	5	9	1	...	...	...	...	...
C93600		81-7-12	81	7	12	...	...	...	...	...	...
C93700		80-10-10	80	10	10	...	...	...	...	...	...
C93800		78-7-15	78	7	15	...	...	...	...	...	...
C94300		71-5-24	71	5	24	...	...	...	...	...	...
Aluminum bronze	C95200	Grade A	88	...	...	...	...	3	9	...	...
	C95300	Grade B	89	...	...	...	...	1	10	...	...
	C95400	Grade C	85	...	...	...	...	4	11	...	...
	C95410		84	...	...	...	2	4	10	...	...
	C95900		82.5	...	...	...	...	4.5	13	...	...
Nickel aluminum bronze	C95500	Grade D	81	...	...	...	4	4	11	...	...
	C95520		78.5	...	...	...	5.5	5.0	11	...	...
	C95800		81.3	...	...	...	4.5	4	9	1.2	...
Leaded nickel bronze	C97300	12 % leaded nickel silver	57	2	9	20	12	...	...	...	...
	C97600	20 % leaded nickel silver	64	4	4	8	20	...	...	...	...
	C97800	25 % leaded nickel silver	66	5	2	2	25	...	...	...	...

<sup>A</sup> Phosphorus 0.13

between the sum of all elements analyzed and 100 %. When all named elements in Table 2 are analyzed, their sum shall be as specified in Table 3.

## 7. Mechanical Properties

7.1 Mechanical properties shall be determined from test bar castings cast in accordance with Practice B208 and shall meet the requirements shown in Table 4.

## 8. Weld Repair

8.1 The castings shall not be weld repaired without customer approval.

## 9. ASME Requirements

9.1 When specified in the purchase order to meet ASME Boiler and Pressure Vessel Code requirements castings in Copper Alloy UNS Nos. C95200 and C95400 shall comply with the following:

9.1.1 Certification requirements of Specification B824.

9.1.2 Foundry test report requirements of Specification B824.

9.1.3 Castings shall be marked with the manufacturer's name, the Copper Alloy UNS No., and the casting quality factor. In addition, heat numbers or serial numbers that are traceable to heat numbers shall be marked on all pressure-containing castings individually weighing 50 lb [22.7 kg] or more. Pressure-containing castings weighing less than 50 lb [22.7 kg] shall be marked with either the heat number or a serial number that will identify the casting as to the month in which it was poured. Marking shall be in such a position as to not injure the usefulness of the casting.

## 10. General Requirements

10.1 The following sections of Specification B824 form a part of this specification. In the event of a conflict between this specification and Specification B824, the requirements of this specification shall take precedence.

10.1.1 Terminology;

10.1.2 Other Requirements;

10.1.3 Dimensions, Mass, and Permissible Variations;

10.1.4 Workmanship, Finish, and Appearance;

10.1.5 Sampling;

10.1.6 Number of Tests and Retests;

TABLE 2 Chemical Requirements

Composition, % max Except as Indicated

Copper Alloy UNS No.	Copper	Tin	Lead	Zinc	Iron	Nickel incl Cobalt	Aluminum	Manganese	Antimony	Sulfur	Phosphorus	Other	Silicon
C83600	84.0–86.0	4.0–6.0	4.0–6.0	4.0–6.0	0.30	1.0 <sup>A</sup>	0.005	...	0.25	0.08	0.05 <sup>B</sup>	...	0.005
C83800	82.0–83.8	3.3–4.2	5.0–7.0	5.0–8.0	0.30	1.0 <sup>A</sup>	0.005	...	0.25	0.08	0.03 <sup>B</sup>	...	0.005
C84400	78.0–82.0	2.3–3.5	6.0–8.0	7.0–10.0	0.40	1.0 <sup>A</sup>	0.005	...	0.25	0.08	0.02 <sup>B</sup>	...	0.005
C84800	75.0–77.0	2.0–3.0	5.5–7.0	13.0–17.0	0.40	1.0 <sup>A</sup>	0.005	...	0.25	0.08	0.02 <sup>B</sup>	...	0.005
C85200	70.0–74.0	0.7–2.0	1.5–3.8	20.0–27.0	0.6	1.0 <sup>A</sup>	0.005	...	0.20	0.05	0.02	...	0.05
C85400	65.0–70.0	0.50–1.5	1.5–3.8	24.0–32.0	0.7	1.0 <sup>A</sup>	0.35	...	...	...	...	...	0.05
C85470	60.0–65.0	1.0–4.0	0.09	Rem	0.20	...	0.10–1.0	...	...	...	0.02–0.25	...	...
C85700	58.0–64.0	0.50–1.5	0.8–1.5	32.0–40.0	0.7	1.0 <sup>A</sup>	0.8	...	...	...	...	...	0.05
C86100	66.0–68.0 <sup>A</sup>	0.20	0.20	Rem	2.0–4.0	...	4.5–5.5	2.5–5.0	...	...	...	...	...
C86200	60.0–66.0	0.20	0.20	22.0–28.0	2.0–4.0	1.0 <sup>A</sup>	3.0–4.9	2.5–5.0	...	...	...	...	...
C86300	60.0–66.0	0.20	0.20	22.0–28.0	2.0–4.0	1.0 <sup>A</sup>	5.0–7.5	2.5–5.0	...	...	...	...	...
C86400	56.0–62.0	0.50–1.5	0.50–1.5	34.0–42.0	0.40–2.0	1.0 <sup>A</sup>	0.50–1.5	0.10–1.5	...	...	...	...	...
C86500	55.0–60.0	1.0	0.40	36.0–42.0	0.40–2.0	1.0 <sup>A</sup>	0.50–1.5	0.10–1.5	...	...	...	...	...
C86700	55.0–60.0	1.5	0.50–1.5	30.0–38.0	1.0–3.0	1.0 <sup>A</sup>	1.0–3.0	0.10–3.5	...	...	...	...	...
C87300	94.0 min	...	0.09	0.25	0.20	...	...	0.8–1.5	...	...	...	...	3.5–4.5
C87400	79.0 min	...	1.0	12.0–16.0	...	...	0.8	...	...	...	...	...	2.5–4.0
C87500	79.0 min	...	0.09	12.0–16.0	...	...	0.50	...	...	...	...	...	3.0–5.0
C87600	88.0 min	...	0.09	4.0–7.0	0.20	...	...	0.25	...	...	...	...	3.5–5.5
C90300	86.0–89.0	7.5–9.0	0.30	3.0–5.0	0.20	1.0 <sup>A</sup>	0.005	...	0.20	0.05	0.05	...	0.005
C90500	86.0–89.0	9.0–11.0	0.30	1.0–3.0	0.20	1.0 <sup>A</sup>	0.005	...	0.20	0.05	0.05	...	0.005
C92200	86.0–90.0	5.5–6.5	1.0–2.0	3.0–5.0	0.25	1.0 <sup>A</sup>	0.005	...	0.25	0.05	0.05	...	0.005
C92300	85.0–89.0	7.5–9.0	0.30–1.0	2.5–5.0	0.25	1.0 <sup>A</sup>	0.005	...	0.25	0.05	0.05	...	0.005
C93200	81.0–85.0	6.3–7.5	6.0–8.0	1.0–4.0	0.20	1.0 <sup>A</sup>	0.005	...	0.35	0.08	0.15	...	0.005
C93500	83.0–86.0	4.3–6.0	8.0–10.0	2.0	0.20	1.0 <sup>A</sup>	0.005	...	0.30	0.08	0.05	...	0.005
C93600	79.0–83.0	6.0–8.0	11.0–13.0	1.0	0.20	1.0 <sup>A</sup>	0.005	...	0.55	0.08	0.15	...	0.005
C93700	78.0–82.0	9.0–11.0	8.0–11.0	0.8	0.7 <sup>C</sup>	0.50 <sup>A</sup>	0.005	...	0.50	0.08	0.10	...	0.005
C93800	75.0–79.0	6.3–7.5	13.0–16.0	0.8	0.15	1.0 <sup>A</sup>	0.005	...	0.8	0.08	0.05	...	0.005
C94300	67.0–72.0	4.5–6.0	23.0–27.0	0.8	0.15	1.0 <sup>A</sup>	0.005	...	0.8	0.08	0.05	...	0.005
C95200	86.0 min	...	...	...	2.5–4.0	...	8.5–9.5	...	...	...	...	...	...
C95300	86.0 min	...	...	...	0.8–1.5	...	9.0–11.0	...	...	...	...	...	...
C95400	83.0 min	...	...	...	3.0–5.0	1.5	10.0–11.5	0.50	...	...	...	...	...
C95410	83.0 min	...	...	...	3.0–5.0	1.5–2.5	10.0–11.5	0.50	...	...	...	...	...
C95500	78.0 min	...	...	...	3.0–5.0	3.0–5.5	10.0–11.5	3.5	...	...	...	...	...
C95520	74.5 min	0.25	0.03	0.30	4.0–5.5	4.2–6.0	10.5–11.5	1.5	...	...	...	Cr 0.05 Co 0.20	0.15
C95800	79.0 min	...	0.03	...	3.5–4.5 <sup>D</sup>	4.0–5.0 <sup>D</sup>	8.5–9.5	0.8–1.5	...	...	...	...	0.10
C95900	rem.	...	...	...	3.0–5.0	0.50	12.0–13.5	1.5	...	...	...	...	...
C97300	53.0–58.0	1.5–3.0	8.0–11.0	17.0–25.0	1.5	11.0–14.0	0.005	0.50	0.35	0.08	0.05	...	0.15
C97600	63.0–67.0	3.5–4.5	3.0–5.0	3.0–9.0	1.5	19.0–21.5	0.005	1.0	0.25	0.08	0.05	...	0.15
C97800	64.0–67.0	4.0–5.5	1.0–2.5	1.0–4.0	1.5	24.0–27.0	0.005	1.0	0.20	0.08	0.05	...	0.15

<sup>A</sup> In determining copper minimum, copper may be calculated as copper plus nickel.

<sup>B</sup> For Continuous Castings, P shall be 1.5 % max.

<sup>C</sup> Iron shall be 0.35 % max. when used for Steel-backed.

<sup>D</sup> Iron content shall not exceed nickel content.

ASME BPVC Section II part B) 2025

TABLE 3 Sum of All Named Elements Analyzed

Copper Alloy UNS No.	Copper Plus Named Elements % min	Copper Alloy UNS No.	Copper Plus Named Elements % min
C83600	99.3	C92200	99.3
C83800	99.3	C92300	99.3
C84400	99.3	C93200	99.2
C84800	99.3	C93500	99.4
C85200	99.1	C93600	99.3
C85400	98.9	C93700	99.0
C85470	99.5	C93800	98.9
C85700	98.7	C94300	99.0
C86100	99.0	C95200	99.0
C86200	99.0	C95300	99.0
C86300	99.0	C95400	99.5
C86400	99.0	C95410	99.5
C86500	99.0	C95500	99.5
C86700	99.0	C95520	99.5
C87300	99.5	C95800	99.5
C87400	99.2	C95900	99.5
C87500	99.5	C97300	99.0
C87600	99.5	C97600	99.7
C90300	99.4	C97800	99.6
C90500	99.7		

- 10.1.7 Specimen Preparation;
- 10.1.8 Test Methods;
- 10.1.9 Significance of Numerical Limits;
- 10.1.10 Inspection;
- 10.1.11 Rejection and Rehearing;
- 10.1.12 Certification;
- 10.1.13 Test Report;
- 10.1.14 Packaging and Package Marking;
- 10.1.15 Supplementary Requirements.

## 11. Sampling

11.1 Test bars shall be made in accordance with Practice B208.

11.2 At the manufacturer's option test bars may be removed from the casting instead of from a separately cast coupon.

11.3 Separately cast test bars representing castings in Copper Alloy UNS Nos. C95300HT, C95400HT, C95410HT, C95500HT, C95520HT, C95800 temper annealed, and C95900 annealed shall be heat treated with the castings.

## 12. Test Methods

12.1 Analytical chemical methods are given in Specification B824.

12.1.1 Test methods to be followed for the determination of elements resulting from contractual or purchase order agreement shall be as agreed upon between the manufacturer or supplier and the purchaser.

12.2 Brinell hardness readings shall be taken on the grip end of the tension test bar and shall be made in accordance with Test Method E10, with the exception that a 3000 kg load shall be used.

## 13. Product Marking

13.1 When specified in the purchase order the castings shall be marked with the alloy number.

## 14. Keywords

14.1 centrifugal castings; copper alloy castings; copper-base alloy castings

TABLE 4 Mechanical Requirements

Copper Alloy UNS No.	Tensile Strength, min		Yield Strength, <sup>A</sup> min		Elongation in 2 in. or 50 mm, min, %	Brinell Hardness No. <sup>B</sup> [3000-kG Load], min
	ksi <sup>C</sup>	MPa <sup>D</sup>	ksi <sup>C</sup>	MPa <sup>D</sup>		
C83600	30	207	14	97	20	...
C83800	30	207	13	90	20	...
C84400	29	200	13	90	18	...
C84800	28	193	12	83	16	...
C85200	35	241	12	83	25	...
C85400	30	207	11	76	20	...
C85470	50	345	21	150	15	...
C85700	40	276	14	97	15	...
C86100	90	620	45	310	18	...
C86200	90	621	45	310	18	...
C86300	110	758	60	414	12	...
C86400	60	414	20	138	15	...
C86500	65	448	25	172	20	...
C86700	80	552	32	221	15	...
C87300	45	310	18	124	20	...
C87400	50	345	21	145	18	...
C87500	60	414	24	165	16	...
C87600	60	414	30	207	16	...
C87610	45	310	18	124	20	...
C90300	40	276	18	124	20	...
C90500	40	276	18	124	20	...
C92200	34	234	16	110	22	...
C92300	36	248	16	110	18	...
C93200	30	207	14	97	15	...
C93500	28	193	12	83	15	...
C93600	32	221	16	110	15	...
C93700	30	207	12	83	15	...
C93800	26	179	14	97	12	...
C94300	24	165	...	...	10	...
C95200	65	450	25	170	20	110
C95300	65	450	25	170	20	110
C95300(HT)	80	550	40	275	12	160
C95400	75	515	30	205	12	150
C95400(HT)	90	620	45	310	6	190
C95410	75	515	30	205	12	150
C95410(HT)	90	620	45	310	6	190
C95500	90	620	40	275	6	190
C95500(HT)	110	760	60	415	5	200
C95520(HT)	125	862	95 <sup>E</sup>	655 <sup>F</sup>	3	262
C95800 <sup>F</sup>	85	585	35	240	15	...
C95900	...	...	...	...	...	241 min
C97300	30	207	15	97	8	...
C97600	40	276	17	117	10	...
C97800	50	345	22	152	10	...

<sup>A</sup> Yield strength shall be determined as the stress producing an elongation under load of 0.5 %, that is 0.01 in. [0.254 mm] in a gage length of 2 in. [50.8 mm].

<sup>B</sup> For information only.

<sup>C</sup> ksi – 1000 psi.

<sup>D</sup> See Appendix.

<sup>E</sup> Yield strength at 0.2 % offset.

<sup>F</sup> As cast or temper annealed.

APPENDIX

(Nonmandatory Information)

X1. HEAT TREATMENT

X1.1 Castings in Copper Alloys UNS Nos. C95300, C95400, C95410, and C95500 may be supplied in the heat treated condition to obtain the higher mechanical properties

shown in Table 4. Suggested heat treatments for these alloys and Copper Alloys UNS No. C95520 are given in Table X1.1. Actual practice may vary by manufacturer.

TABLE X1.1 Suggested Heat Treatments

Copper Alloy UNS No.	Solution Treatment (not less than 1 h followed by water quench)	Annealing Treatment (not less than 2 h followed by air cool)
C95300	1585–1635 °F [860–890 °C]	1150–1225 °F [620–660 °C]
C95400 C95410 C95500	1600–1675 °F [870–910 °C]	1150–1225 °F [620–660 °C]
C95520	(2 h followed by water quench) 1600–1700 °F [870–925 °C]	925–1000 °F [495–540 °C]

X1.2 For better corrosion resistance in seawater applications, castings in Copper Alloys UNS No. C95800 shall be given a temper anneal heat treatment at 1200 to 1300 °F [650 to 705 °C] for 6 h minimum. Cooling shall be by the fastest means possible that will not cause distortion or cracking which renders the castings unusable for the intended application.

X1.3 Castings in Copper Alloys UNS No. C95900 are normally supplied annealed between 1100 °F [595 °C] and 1300 °F [705 °C] for 4 h followed by air cooling.

### SUMMARY OF CHANGES

Committee B05 has identified the location of selected changes to this standard since the last issue (B271/B271M – 15) that may impact the use of this standard. (Approved Oct. 1, 2018.)

- (1) Added UNS Alloy No. C86100 to Table 1, Table 2, Table 3, and Table 4. (2) Revised X1.2.

*ASTM International takes no position respecting the validity of any patent rights asserted in connection with any item mentioned in this standard. Users of this standard are expressly advised that determination of the validity of any such patent rights, and the risk of infringement of such rights, are entirely their own responsibility.*

*This standard is subject to revision at any time by the responsible technical committee and must be reviewed every five years and if not revised, either reapproved or withdrawn. Your comments are invited either for revision of this standard or for additional standards and should be addressed to ASTM International Headquarters. Your comments will receive careful consideration at a meeting of the responsible technical committee, which you may attend. If you feel that your comments have not received a fair hearing you should make your views known to the ASTM Committee on Standards, at the address shown below.*

*This standard is copyrighted by ASTM International, 100 Barr Harbor Drive, PO Box C700, West Conshohocken, PA 19428-2959, United States. Individual reprints (single or multiple copies) of this standard may be obtained by contacting ASTM at the above address or at 610-832-9585 (phone), 610-832-9555 (fax), or service@astm.org (e-mail); or through the ASTM website (www.astm.org). Permission rights to photocopy the standard may also be secured from the Copyright Clearance Center, 222 Rosewood Drive, Danvers, MA 01923, Tel: (978) 646-2600; http://www.copyright.com/*

ASMENORMDOC.COM : Click to view the full PDF of ASME BPVC.II.B (ASME BPVC Section II part B) 2025

INTENTIONALLY LEFT BLANK

## SPECIFICATION FOR COPPER AND COPPER-ALLOY DIE FORGINGS (HOT-PRESSED)



**SB-283/SB-283M**



(25)

(Identical with ASTM Specification B283/B283M-22 except that certification and test reports have been made mandatory; product must conform to mechanical properties in Table 2; and Footnote B added to Table 2.)

*ASME SB-283/SB-283M replaces paras. 5.1.7, 5.2.1, 5.2.2, 9.1, 9.2, and 9.2.1 of ASTM B283/B283M with the following:*

5.1.7 DELETED

5.2.1 DELETED

5.2.2 DELETED

9.1 DELETED

9.2 Product furnished to this specification shall conform to the tensile requirements prescribed in Table 2, when tested in accordance with Test Methods E8/E8M.

9.2.1 DELETED

*ASME SB-283/SB-283M, Table 2 adds Note B to ASTM B283/B283M, Table 2 as follows:*

TABLE 2 Tensile Requirements<sup>B</sup>

<sup>B</sup>The tensile requirements shown where only the M10 temper is listed are also to be used for the O temper.

*ASME SB-283/SB-283M replaces paras. 15 and 15.1 of ASTM B283/B283M with the following:*

### 15. Certification and Test Report

15.1 The certification and test report requirements of specification B249/B249M are mandatory.

ASME SB-283/SB-283M retitles Table X3.1 of ASTM B283/B283M as follows:

Table X3.1 Typical Mechanical Properties of Forgings as Hot Pressed, Temper M10 or TQ50<sup>4</sup>

ASMENORMDOC.COM : Click to view the full PDF of ASME BPVC.II.B (ASME BPVC Section II part B) 2025



Designation: B283/B283M – 22

## Standard Specification for Copper and Copper-Alloy Die Forgings (Hot-Pressed)<sup>1</sup>

This standard is issued under the fixed designation B283/B283M; the number immediately following the designation indicates the year of original adoption or, in the case of revision, the year of last revision. A number in parentheses indicates the year of last reapproval. A superscript epsilon ( $\epsilon$ ) indicates an editorial change since the last revision or reapproval.

*This standard has been approved for use by agencies of the U.S. Department of Defense.*

### 1. Scope\*

1.1 This specification establishes the requirements for copper and copper alloy die forgings produced by the hot pressing method. The following copper and copper alloys are included:

Copper or Copper Alloy UNS No.	Name
C11000	copper
C14500	copper-tellurium
C14700	copper-sulfur
C27450	plumbing brass
C27451	plumbing brass
C27453	copper zinc alloy
C28500	copper-zinc brass
C35330	leaded brass
C36300	copper-zinc-lead
C36500	leaded Muntz metal
C37000	free-cutting Muntz metal
C37700	forging brass
C46400	naval brass
C46500	naval brass, arsenical
C46750	tin brass
C48200	medium leaded naval brass
C48500	leaded naval brass
C48600	naval brass
C48640	DZR brass
C48645	DZR tin brass
C49250	copper-zinc-bismuth alloy
C49255	copper-zinc-bismuth-nickel alloy
C49260	copper-zinc-bismuth alloy
C49265	copper-zinc-tin-bismuth, low leaded
C49300	copper-zinc-tin-bismuth alloy
C49340	copper-zinc-tin-bismuth alloy
C49345	copper-zinc-tin-bismuth, low leaded
C49350	copper-zinc-tin-bismuth alloy
C49355	bismuth brass
C61900	aluminum bronze
C62300	aluminum bronze, 9 %
C63000	aluminum-nickel bronze
C63200	aluminum-nickel bronze
C64200	aluminum-silicon bronze
C64210	aluminum-silicon bronze, 6.7 %
C65500	high-silicon bronze (A)
C65680	high-silicon bronze
C67500	manganese bronze (A)
C67600	...
C69300	copper-zinc-silicon
C69410	copper-zinc-silicon

Copper or Copper Alloy UNS No.	Name
C69850	copper-zinc-silicon
C70620	copper-nickel 90-10
C71520	copper-nickel 70-30
C77400	nickel silver, 45-10
C87700	silicon bronze
C87710	silicon bronze

Copper Alloy EN 1412 Nos.	Name
CW612N	forging brass
CW617N	forging brass

1.2 *Units*—The values stated in either SI units or inch-pound units are to be regarded separately as standard. The values stated in each system are not necessarily exact equivalents; therefore, to ensure conformance with the standard, each system shall be used independently of the other and values from the two systems shall not be combined.

NOTE 1—Nominal composition and relative forgeability ratings are given in Appendix X1. Copper-nickel alloys C70620 and C71520 are intended for welded applications with seawater exposure.

NOTE 2—Guidelines for design and development of forgings are included in Appendix X2.

NOTE 3—Wrought product intended for hot forging is described in Specification B124/B124M.

1.3 The following safety caveat pertains only to Section 10 of this specification. *This standard does not purport to address all of the safety concerns, if any, associated with its use. It is the responsibility of the user of this standard to establish appropriate safety, health, and environmental practices and determine the applicability of regulatory limitations prior to use.*

1.4 *This international standard was developed in accordance with internationally recognized principles on standardization established in the Decision on Principles for the Development of International Standards, Guides and Recommendations issued by the World Trade Organization Technical Barriers to Trade (TBT) Committee.*

### 2. Referenced Documents

#### 2.1 ASTM Standards:<sup>2</sup>

B124/B124M Specification for Copper and Copper Alloy

<sup>1</sup> This specification is under the jurisdiction of ASTM Committee B05 on Copper and Copper Alloys and is the direct responsibility of Subcommittee B05.02 on Rod, Bar, Wire, Shapes and Forgings.

Current edition approved Oct. 1, 2022. Published October 2022. Originally approved in 1953. Last previous edition approved in 2020 as B283/B283M–20. DOI: 10.1520/B0283\_B0283M-22.

<sup>2</sup> For referenced ASTM standards, visit the ASTM website, www.astm.org, or contact ASTM Customer Service at service@astm.org. For *Annual Book of ASTM Standards* volume information, refer to the standard's Document Summary page on the ASTM website.

Forging Rod, Bar, and Shapes  
 B249/B249M Specification for General Requirements for Wrought Copper and Copper-Alloy Rod, Bar, Shapes and Forgings  
 B846 Terminology for Copper and Copper Alloys  
 E8/E8M Test Methods for Tension Testing of Metallic Materials  
 E62 Test Methods for Chemical Analysis of Copper and Copper Alloys (Photometric Methods) (Withdrawn 2010)<sup>3</sup>  
 E75 Test Methods for Chemical Analysis of Copper-Nickel and Copper-Nickel-Zinc Alloys (Withdrawn 2010)<sup>3</sup>  
 E478 Test Methods for Chemical Analysis of Copper Alloys

#### 2.2 Other Standards:

ASME Boiler and Pressure Vessel Code<sup>4</sup>  
 EN 1412 Copper and Copper Alloys – European Numbering System<sup>5</sup>  
 ISO 7602 Determination of Tellurium Content (High Content)—Flame Atomic Absorption Spectrometric Method<sup>6</sup>  
 JIS H 1068:2005 Method for Determination of Bismuth in Copper and Copper Alloys<sup>7</sup> (Japanese Industrial Standards)

#### 2.3 Military Standards:<sup>8</sup>

MIL-STD-792 Identification Marking Requirements for Special Purpose Components  
 NAVSEA T9074-AS-GIB-010/271 Requirements for Non-destructive Testing Method

### 3. General Requirements

3.1 The following sections of Specification B249/B249M constitute a part of this specification:

- 3.1.1 Terminology;
- 3.1.2 Materials and Manufacture;
- 3.1.3 Workmanship, Finish, and Appearance;
- 3.1.4 Sampling;
- 3.1.5 Number of Tests and Retests;
- 3.1.6 Specimen Preparation;
- 3.1.7 Test Methods;
- 3.1.8 Significance of Numerical Limits;
- 3.1.9 Inspection;
- 3.1.10 Rejection and Rehearing;
- 3.1.11 Certification;
- 3.1.12 Test Reports;
- 3.1.13 Packaging and Package Marking; and
- 3.1.14 Supplementary Requirements.

<sup>3</sup> The last approved version of this historical standard is referenced on [www.astm.org](http://www.astm.org).

<sup>4</sup> Available from American Society of Mechanical Engineers (ASME), ASME International Headquarters, Two Park Ave., New York, NY 10016-5990, <http://www.asme.org>.

<sup>5</sup> Available from EN Standard Store, Krimicka 134, 318 13 Pilsen, Czech Republic, <https://www.en-standard.eu/>.

<sup>6</sup> Available from American National Standards Institute (ANSI), 25 W. 43rd St., 4th Floor, New York, NY 10036, <http://www.ansi.org>.

<sup>7</sup> Available from Japanese Standards Association (JSA), Mita MT Bldg., 3-13-12 Mita, Minato-ku, Tokyo, 108-0073, Japan, <http://www.jsa.or.jp>.

<sup>8</sup> Available from DLA Document Services, Building 4/D, 700 Robbins Ave., Philadelphia, PA 19111-5094, <http://quicksearch.dla.mil/>.

3.1.15 In addition, when a section with a title identical to one of those referenced in 3.1, above, appears in this specification, it contains additional requirements that supplement those appearing in Specification B249/B249M.

### 4. Terminology

#### 4.1 Definitions:

4.1.1 For definitions of terms related to copper and copper alloys, refer to Terminology B846.

#### 4.2 Definitions of Terms Specific to This Standard:

4.2.1 *hot pressed forging, n*—a product made by pressing a heated blank or section of wrought or cast copper or copper alloy in a closed impression die.

### 5. Ordering Information

5.1 Include the following information when placing orders for products to this specification, as applicable:

- 5.1.1 ASTM designation and year of issue;
- 5.1.2 Copper or Copper Alloy UNS No. or EN 1412 No. designation (Scope);
- 5.1.3 Drawing showing the shape dimensions and tolerances (Dimensions and Permissible Variations);
- 5.1.4 Temper (as specified herein);
- 5.1.5 Quantity, total weight or number of pieces for each form, temper, and copper or copper alloy;
- 5.1.6 When product is purchased for agencies of the U.S. Government (as specified herein); and
- 5.1.7 When product must adhere to the requirements of *ASME Boiler and Pressure Vessel Code* (Mechanical Property Requirements).

5.2 The following requirements are optional and shall be specified in the contract or purchase order.

- 5.2.1 Certification (as specified herein and Supplementary Requirements),
- 5.2.2 Mill test report (as specified in Specification B249/B249M), and
- 5.2.3 Ultrasonic inspection report (Supplementary Requirements).

### 6. Materials and Manufacture

#### 6.1 Materials:

6.1.1 The material of manufacture shall be a form of rods, billets, or blanks cut from cast or wrought material of one of the copper or copper alloys listed in the Scope of this specification and of such purity and soundness as to be suitable for processing into the products prescribed herein.

6.1.2 In the event heat identification or traceability is required, the purchaser shall specify the details desired.

NOTE 4—Due to the discontinuous nature of the processing of castings into wrought products, it is not always practical to identify specific casting analysis with a specific quantity of finished material.

#### 6.2 Manufacture:

6.2.1 The product shall be manufactured by hot pressing material between the upper and lower sections of a set of dies conforming to the configuration defined by the purchaser's submitted drawings.

6.2.2 Product of Copper Alloy UNS No. C63000 and C63200 shall be heat treated (as specified herein).

## 7. Chemical Composition

7.1 The material shall conform to the chemical composition requirements in Table 1 for the Copper or Copper Alloy UNS No. designation specified in the ordering information.

7.2 These composition limits do not preclude the presence of other elements. By agreement between the manufacturer and purchaser, limits may be established and analysis required for unnamed elements.

7.2.1 For alloys in which copper is listed as “remainder,” copper is the difference between the sum of results of all elements determined and 100 %.

7.2.2 For alloys in which zinc is listed as “remainder,” either copper or zinc may be taken as the difference between the sum of results of all other elements determined and 100 %.

7.3 When all the elements in Table 1 are determined for Copper Alloy C65680, the sum of results shall be 99.2 % min. When all elements in Table 1 are determined for Copper Alloy UNS Nos. C36500, C37000, C46400, C46500, C48200, C48500, C48600, the sum of results shall be 99.6 % min; for Copper Alloy UNS No. C28500, the sum of results shall be 99.1 % min; for EN 1412 Nos. CW612N and CW617N, the sum of the results shall be 99.8 % min; and for all other alloys, the sum of results shall be 99.5 % min.

## 8. Temper

8.1 The standard tempers for products described in this specification are as follows:

8.1.1 As hot forged-air cooled M10,

8.1.2 Hot forged and annealed O20.

8.2 Alloys C70620 and C71520 shall be furnished in the following tempers:

8.2.1 As hot forged-air cooled M10, unless,

8.2.2 Hot forged and annealed O20 is specified.

8.3 Other tempers shall be subjected to agreement between the manufacturer and the purchaser.

## 9. Mechanical Property Requirements

9.1 Mechanical property requirements are subject to agreement between the manufacturer and the purchaser.

9.2 Product furnished to this specification for UNS Alloy No. C70620 and C71520 and specified to meet the requirements of the *ASME Boiler and Pressure Vessel Code* shall conform to the tensile requirements prescribed in Table 2, when tested in accordance with Test Methods E8/E8M.

9.2.1 Acceptance or rejection based upon mechanical properties for UNS Alloy No. C70620 and C71520 shall depend only on tensile strength.

## 10. Heat Treatment

10.1 Product produced from Copper Alloy UNS Nos. C63000 and C63200 shall be heat treated as follows:

10.1.1 Heat to 1550 °F [843 °C] minimum for 1 h minimum and quench in water or other suitable medium.

10.1.2 Temper Anneal at 1300 °F ± 25 °F [704 °C ± 14 °C] for 3 to 9 h as required to meet mechanical properties.

10.2 Heat treatment of other alloys, if needed, to be established by specific agreement between the supplier and purchaser.

## 11. Special Government Requirements

11.1 Product purchased for agencies of the U.S. Government shall conform to the additional requirements prescribed in the Supplementary Requirements section of this specification.

## 12. Dimensions, Mass, and Permissible Variations

12.1 The dimensions and tolerances for forgings shall be those agreed upon between the manufacturer and the purchaser, and such dimensions and tolerances shall be specified on the drawings which form a part of the contract or purchase order.

NOTE 5—Typical tolerances commonly used for forgings are shown in Table X2.1.

NOTE 6—Typical deviations for mismatch, flatness, ejector marks, flash projection, and die parting line are included in the Appendix X2.

## 13. Workmanship, Finish, and Appearance

13.1 The forging process gives to the forgings a surface condition related to the hot forging process itself. Ridges, indentations, folds, shocks from automatic hot forging, smooth flow lines due to brass rod slug positioning and material flow, that do not have deleterious effects in use, shall not be cause for rejection.

13.2 Customer-specific requirements for as-forged surface quality shall be by agreement between the purchaser and supplier.

## 14. Test Methods

### 14.1 Chemical Analysis:

14.1.1 In cases of disagreement, test methods for chemical analysis shall be subject to agreement between the manufacturer or supplier and the purchaser. The following table is a list of published methods, some of which may no longer be viable, which along with others not listed, may be used subject to agreement.

Element	ASTM Test Method
Aluminum	E478
Antimony	E62
Arsenic	E62
Bismuth	JIS H 1068:2005
Copper	E478
Iron	E478, E75 for CuNi
	E478, E75 for CuNi
	E478 (AA)
Lead	E478 (AA)
Manganese	E62, E75 for CuNi
Nickel	E478 (photometric)
	E478 (gravimetric)
Phosphorus	E62
Silicon	E62 (perchloric acid)
Tin	E478
	E478
Zinc	E478 (AA)
	E478 (titrimetric)
	ISO Test Method 7602
Tellurium	

NOTE— < = less than; > = greater than

TABLE 1 Chemical Requirements

Copper or Copper Alloy UNS or EN 1412 No.	Composition, %													
	Copper	Lead	Tin	Iron	Nickel (incl Co)	Aluminum	Silicon	Manganese	Zinc	Sulfur	Tellurium	Phosphorus	Arsenic	Bismuth
C11000	99.90 <sup>A</sup> min	...	...	...	...	...	...	...	...	...	...	...	...	...
C14500 <sup>B</sup>	99.90 <sup>C</sup> min	...	...	...	...	...	...	...	...	0.40–0.7	0.004–0.012 <sup>D</sup>	...	...	...
C14700 <sup>B</sup>	99.90 <sup>E</sup> min	...	...	...	...	...	...	...	0.20–0.50	...	0.002–0.005 <sup>D</sup>	...	...	...
C27450	60.0–65.0	0.25 max	...	0.35 max	...	...	...	remainder	...	...	...	...	...	...
C27451	61.0–65.0	0.25 max	...	0.35 max	...	...	...	remainder	...	...	0.05–0.20	...	...	...
C27453	61.5–63.5	0.25 max	0.15 max	0.15 max	...	...	...	remainder	...	...	...	0.02–0.15	...	...
C28500	57.0–59.0	0.25 max	...	0.35 max	...	...	...	remainder	...	...	...	...	...	...
C35330	59.5–64.0	1.5–3.5	...	...	...	...	...	remainder	...	...	...	0.02–0.25	...	...
C36300	61.0–63.0	0.25–0.7	...	0.15 max	...	...	...	remainder	...	...	0.04–0.15	...	...	...
C36500	58.0–61.0	0.25–0.7	0.25 max	0.15 max	...	...	...	remainder	...	...	...	...	...	...
C37000	59.0–62.0	0.8–1.5	...	0.15 max	...	...	...	remainder	...	...	...	...	...	...
C37700	58.0–61.0	1.5–2.5	...	0.30 max	...	...	...	remainder	...	...	...	...	...	...
C46400	59.0–62.0	0.20 max	0.50–1.0	0.10 max	...	...	...	remainder	...	...	...	...	...	...
C46500	59.0–62.0	0.20 max	0.50–1.0	0.10 max	...	...	...	remainder	...	...	...	0.02–0.06	...	...
C46750 <sup>F</sup>	59.2–62.5	0.25 max	1.00–1.80	0.10 max	0.50 max	...	...	remainder	...	...	0.05–0.15	...	...	...
C48200	59.0–62.0	0.40–1.0	0.50–1.0	0.10 max	...	...	...	remainder	...	...	...	...	...	...
C48500	59.0–62.0	1.3–2.2	0.50–1.0	0.10 max	...	...	...	remainder	...	...	...	...	...	...
C48600	59.0–62.0	1.0–2.5	0.30–1.5	...	...	...	...	remainder	...	...	...	0.02–0.25	...	...
C48640	59.0–62.0	1.5–3.0	0.50–2.0	0.40 max	0.3 max <sup>G</sup>	...	...	remainder	...	...	0.05–0.25	...	...	...
C48645	60.0–63.0	1.0–2.5	0.10–1.5	0.30 max	0.10–1.0 <sup>G</sup>	...	...	remainder	...	...	0.02–0.25	...	...	...
C49250 <sup>H</sup>	58.0–61.0	0.09 max	0.30 max	0.50 max	...	...	...	remainder	...	...	...	...	...	1.8–2.4
C49255 <sup>I</sup>	58.0–60.0	0.09 max	0.50 max	0.10 max	0.3 max <sup>G</sup>	...	0.10 max	remainder	...	...	0.10 max	...	...	1.7–2.9
C49260 <sup>H</sup>	58.0–63.0	0.09 max	0.50 max	0.50 max	...	...	0.10 max	remainder	...	...	0.05–0.15	...	...	0.50–1.8
C49265 <sup>H</sup>	58.0–62.0 <sup>A</sup>	0.09–0.25	0.50 max	0.30 max	...	...	0.10 max	remainder	...	...	0.05–0.12	...	...	0.50–1.3
C49300 <sup>J</sup>	58.0–62.0	0.09 max	1.0–1.8	0.10 max	0.3 max <sup>G</sup>	...	0.10 max	remainder	...	...	...	...	...	0.5–2.5
C49340 <sup>H</sup>	60.0–63.0	0.09 max	0.50–1.5	0.12 max	...	...	0.10 max	remainder	...	...	0.05–0.15	...	...	0.50–2.2
C49345 <sup>H</sup>	60.0–64.0 <sup>A</sup>	0.09–0.25	0.50–1.5	0.30 max	...	...	0.10 max	remainder	...	...	0.05–0.12	...	...	0.50–1.3
C49350 <sup>K</sup>	61.0–63.0	0.09 max	1.5–3.0	0.12 max	...	...	0.30 max	remainder	...	...	0.04–0.15	...	...	0.50–2.5
C49355 <sup>L</sup>	63.0–69.0	0.09 max	0.50–2.0	0.10 max	...	...	1.0–2.0	0.10 max	27.0–35.0	...	...	...	...	0.50–1.5

ASMENORMDOC.COM : Click to view the full PDF of ASME BPVC.II.B (ASME BPVC Section II part B) 2025

TABLE 1 Continued

Copper or Copper Alloy UNS or EN 1412 No.	Composition, %													
	Copper	Lead	Tin	Iron	Nickel (incl Co)	Aluminum	Silicon	Manganese	Zinc	Sulfur	Tellurium	Phosphorus	Arsenic	Bismuth
C61900	remainder	0.02 max	0.6 max	3.0–4.5 <sup>M</sup>	...	8.5–10.00	...	...	0.8 max	...	...	...	...	...
C62300	remainder	...	0.6 max	2.0–4.0	1.0 max	8.5–10.0	0.25 max	0.50 max	...	...	...	...	...	...
C63000	remainder	...	0.20 max	2.0–4.0	4.0–5.5	9.0–11.0	0.25 max	1.5 max	0.30 max	...	...	...	...	...
C63200	remainder	0.02 max	...	3.5–4.3 <sup>N</sup>	4.0–4.8	8.7–9.5	0.10 max	1.2–2.0	...	...	...	...	...	...
C64200	remainder	0.05 max	0.20 max	0.30 max	0.25 max	6.3–7.6	1.5–2.2	0.10 max	0.50 max	...	...	...	0.09 max	...
C64210	remainder	0.05 max	0.20 max	0.30 max	0.25 max	6.3–7.0	1.50–2.0	0.10 max	0.50 max	...	...	...	0.09 max	...
C65500	remainder	0.05 max	...	0.8 max	0.6 max	...	2.8–3.8	0.50–1.3	1.5 max	...	...	...	...	...
C65680	84.0 min	0.09 max	0.30 max	0.30 max	0.10 max <sup>G</sup>	0.30 max	2.5–4.5	0.01–0.09	7.0–11.0	...	...	0.05–0.15	...	...
C67500	57.0–60.0	0.20 max	0.50–1.5	0.8–2.0	...	0.25 max	...	0.05–0.50	remainder	...	...	...	...	...
C67600	57.0–60.0	0.50–1.0	0.50–1.5	0.40–1.3	...	...	...	0.05–0.50	remainder	...	...	...	...	...
C69300	73.0–77.0	0.09 max	0.20 max	0.10 max	0.10 max	...	2.7–3.4	0.10 max	remainder	...	...	0.04–0.15	...	...
C69410	81.0 min	0.09 max	...	0.20 max	...	...	3.5–4.5	...	11.0–15.0	...	...	...	...	...
C69850	67.5–69.0	0.09 max	0.20 max	0.10 max	0.10 max <sup>G</sup>	...	1.53–2.0	0.10 max	remainder	...	...	0.04–0.15	...	...
C70620 <sup>O</sup>	86.5 <sup>A</sup> min	0.02 max	...	1.0–1.8	9.0–11.0	...	...	1.0 max	0.50 max	0.02 max	...	0.02 max	...	...
C71520 <sup>O</sup>	65.0 <sup>A</sup> min	0.02 max	...	0.40–1.0	29.0–33.0	...	...	1.0 max	0.50 max	0.02 max	...	0.02 max	...	...
C77400	43.0–47.0	0.09 max	...	...	9.0–11.0	...	...	...	remainder	...	...	...	...	...
C87700 <sup>P</sup>	87.5 min	0.09 max	2.0 max	0.50 max	0.25 max	...	2.5–3.5	0.8 max	7.0–9.0	...	...	0.15 max	...	...
C87710 <sup>P</sup>	84.0 min	0.09 max	2.0 max	0.50 max	0.25 max	...	3.0–5.0	0.8 max	9.0–11.0	...	...	0.15 max	...	...
CW612N	59.0–60.0	1.6–2.5	0.3 max	0.3 max	0.3 max <sup>G</sup>	0.05 max	...	...	remainder	...	...	...	...	...
CW617N	57.0–59.0	1.6–2.5	0.3 max	0.3 max	0.3 max <sup>G</sup>	0.05 max	...	...	remainder	...	...	...	...	...

<sup>A</sup> Silver counting as copper.

<sup>B</sup> Includes oxygen-free or deoxidized grades with deoxidizers (such as phosphorus, boron, lithium, or others) in amount agreed upon.

<sup>C</sup> This includes copper plus silver plus tellurium plus phosphorus.

<sup>D</sup> Other deoxidizers may be used as agreed upon, in which case phosphorus need not be present.

<sup>E</sup> This includes copper plus silver plus sulfur plus phosphorus.

<sup>F</sup> Includes antimony 0.05–0.15.

<sup>G</sup> Not including Co.

<sup>H</sup> Includes cadmium 0.001 % max.

<sup>I</sup> Includes cadmium 0.0075 % max, selenium 0.02–0.07.

<sup>J</sup> Includes cadmium 0.0075 % max, antimony 0.50 % max, and selenium 0.20 % max.

<sup>K</sup> Includes antimony 0.02–0.10 %.

<sup>L</sup> Includes Boron 0.001 % max.

<sup>M</sup> For boiler code application maximum iron content shall be 4.0 %.

<sup>N</sup> Iron content shall not exceed nickel content.

<sup>O</sup> Carbon shall be 0.05 % max.

<sup>P</sup> Antimony shall be 0.10 Max.

TABLE 2 Tensile Requirements

Diameter or Section Thickness, in. [mm]	Temper Designation Standard Former	Tensile Strength, min		Yield Strength at 0.5 % Extension Under Load, min		Elongation in 4 × Diameter or Thickness of Specimen, min, %
		ksi	[MPa] <sup>A</sup>	ksi	[MPa] <sup>A</sup>	
Copper Alloy UNS No. C27450, C27451						
All Sizes	M10 As Hot Forged-Air Cooled	50	[345]	18	[124]	25
Copper Alloy UNS No. C27453						
All Sizes	M10 As Hot Forged-Air Cooled	49	[340]	29	[200]	30
Copper Alloy UNS No. C28500						
All Sizes	M10 As Hot Forged-Air Cooled	58	[400]	24	[165]	20
Copper Alloy UNS Nos. C35330 and C37700 and EN 1412 Alloy Nos. CW612N and CW617N						
Up to 1½ [38.1], incl Over 1½ [38.1]	M10 As Hot Forged-Air Cooled	50	[345]	18	[124]	25
	M10 As Hot Forged-Air Cooled	46	[317]	15	[103]	30
Copper Alloy UNS No. C36300						
All sizes	M10 As Hot Forged-Air Cooled	50	[345]	18	[124]	25
Copper Alloy UNS No. C46400						
All sizes	M10 As Hot Forged-Air Cooled	52	[358]	22	[152]	25
Copper Alloy UNS No. C46500						
All sizes	M10 As Hot Forged-Air Cooled	63	[435]	30	[207]	40
Copper Alloy UNS No. C46750						
All sizes	M10 As Hot Forged-Air Cooled	45.7	[315]	22.0	[152]	15
	O20 Hot Forged and Annealed	45.7	[315]	22.0	[152]	15
Copper Alloy UNS Nos. C48200, C48500, C48600, C49250, C49255, C49260, C49265, and C49300						
All sizes	M10 As Hot Forged-Air Cooled	52	[358]	22	[152]	25
Copper Alloy UNS No. C48640, C48645						
All sizes	M10 As Hot Forged-Air Cooled	45.7	[315]	18	[124]	15
	O20 Hot Forged and Annealed	45.7	[315]	18	[124]	15
Copper Alloy UNS Nos. C49340, C49345, and C49350						
All sizes	M10 As Hot Forged-Air Cooled	50	[345]	20	[140]	20
Copper Alloy UNS No. C49355						
All Sizes	M10 As Hot Forged-Air Cooled	50	[345]	20	[140]	15
All Sizes	O20 Hot Forged and Annealed	50	[345]	20	[140]	15
Copper Alloy UNS No. C64200						
Up to 1½ [38.1], incl Over 1½ [38.1]	M10 As Hot Forged-Air Cooled	70	[483]	25	[172]	30
	M10 As Hot Forged-Air Cooled	68	[469]	23	[156]	35
Copper Alloy UNS No. C65680						
All Sizes	M10 As Hot Forged-Air Cooled	43.5	[300]	14.5	[100]	8
All Sizes	O20 Hot Forged and Annealed	29.0	[200]	11.6	[80]	15
Copper Alloy UNS No. C69300						
All sizes	M10 As Hot Forged-Air Cooled	65	[450]	26	[180]	15
Copper Alloy UNS No. C69850						
All sizes	M10 As Hot Forged-Air Cooled	55	[379]	22	[151]	15
Copper Alloy UNS No. C70620						
Up to 6 [152], incl Over 6 [152]	M10 As Hot Forged-Air Cooled	45	[310]	18	[124]	30
	M10 As Hot Forged-Air Cooled	40	[276]	15	[103]	30
All sizes	O20 Hot Forged and Annealed	40	[276]	15	[103]	30
Copper Alloy UNS No. C71520						
Up to 6 [152], incl Over 6 [152]	M10 As Hot Forged-Air Cooled	50	[345]	20	[138]	30
	M10 As Hot Forged-Air Cooled	45	[310]	18	[124]	30
All sizes	O20 Hot Forged and Annealed	45	[310]	18	[124]	30
Copper Alloy UNS No. C69410, C87700 and C87710						
All sizes	M10 as Hot Forged-Air Cooled	40	[310]	15	[103]	15

<sup>A</sup> See Appendix X5.

14.1.2 Test method(s) to be followed for the determination of element(s) resulting from contractual or purchase order agreement shall be as agreed upon between the manufacturer or supplier and purchaser.

**15. Certification**

15.1 Certification to this specification is mandatory for product purchased for ASME Boiler and Pressure Vessel applications.

**16. Keywords**

16.1 copper and copper alloy die forgings (hot pressed); die forgings (hot pressed); EN 1412 No. CW612N; EN 1412 No. CW617N; UNS No. C11000; UNS No. C14500; UNS No. C14700; UNS No. C27450; UNS No. C27451; UNS No.

C27453; UNS No. C28500; UNS No. C35330; UNS No. C36300; UNS No. C36500; UNS No. C37000; UNS No. C37700; UNS No. C46400; UNS No. C46500; UNS No. C46750; UNS No. C48200; UNS No. C48500; UNS No. C48600; UNS No. C48640; UNS No. C48645; UNS No. C49250; UNS No. C49255; UNS No. C49260; UNS No. C49265; UNS No. C49300; UNS No. C49340; UNS No. C49345; UNS No. C49350; UNS No. C49355; UNS No. C61900; UNS No. C62300; UNS No. C63000; UNS No. C63200; UNS No. C64200; UNS No. C64210; UNS No. C65500; UNS No. C65680; UNS No. C67500; UNS No. C67600; UNS No. C69300; UNS No. C69410; UNS No. C69850; UNS No. C70620; UNS No. C71520; UNS No. C77400; UNS No. C87700; UNS No. C87710

## SUPPLEMENTARY REQUIREMENTS

The following supplementary requirements shall apply only when specified by the purchaser in the inquiry, contract, or order for agencies of the U.S. Government.

S1. Supplementary Requirements S1, S2, and S4 of ASTM B249/B249M shall apply.

S2. **Identification Marking**—Individual forgings shall be marked with the producer's name or trademark, this ASTM specification number, the UNS number or the EN 1412 number, and the heat number or serial number. The method and location of marking shall be in accordance with MIL-STD-792. If approved by the purchaser, the forgings may be bundled or boxed and each bundle or box provided with a metal or oil-proof tag showing the above information.

S2.1 **Sampling**—The lot size, portion size, and selection of sample pieces shall be as follows:

1. *Lot Size*—For forgings weighing 250 lb [114 kg] or less, a lot shall be 2000 lb [909 kg] or less, and shall consist of forgings of the same design and alloy forged from the same material heat and heat treated at the same time. For forgings exceeding 250 lb [114 kg], each individual forging shall constitute a lot.

S2.2 *Portion Size*—For forgings less than 250 lb [114 kg], two forgings per lot shall be selected for tensile testing. Tensile tests shall be performed on each forging over 250 lb [114 kg].

S2.3 *Chemical Analysis*—If heat identification is required, one sample for chemical analysis shall be taken for each heat at the time of pouring or from semifinished or finished product.

S2.4 *Tensile Testing*—The tensile specimens shall be taken from integral forging prolongations or shall be removed from the forgings by trepanning. Alternatively, samples may be taken from separately forged test bars of the same heat as the forgings in the lot provided the wall thickness and amount of working for the test bar are equivalent to those for the forgings. The axis of the tensile specimen shall be located at any point midway between the center and the surface of solid forgings and at any point midway between the inner and outer surfaces of the wall of hollow forgings, and shall be parallel to the direction of greatest grain flow to the greatest extent possible.

S2.5 **Liquid Penetrant Inspection**—When specified by the purchaser, each piece of each lot shall be inspected in accordance with NAVSEA T9074-AS-GIB-101/271.

S2.6 **Ultrasonic Inspection**—When specified by the purchaser, each piece of each lot shall be inspected.

1. *General Requirements*—Ultrasonic testing shall be performed in accordance with NAVSEA T9074-AS-GIB-101/271. Acoustic compatibility between the production material and the calibration standard material shall be within 75 %. If the acoustic compatibility is within 25 %, no gain compensation is required for the examination. If the acoustic compatibility difference is between 25 % and 75 %, a change in the gain or dB controls shall be accomplished to compensate for the differences in acoustic compatibility. This method cannot be used if the ultrasonic noise level exceeds 50 % of the rejection value.

S3. *Calibration:*

S3.1 *Shear Wave*—The shear wave test shall be calibrated on two notches, one notch cut into the inside and one into the outside surface. The notches shall be cut axially and shall have a depth of 5 % of the material thickness or ¼ in. [6.4 mm], whichever is less. Notch length shall not exceed 1 in. [25.4 mm]. Notches shall be made either in the piece to be examined or in a separate defect-free specimen of the same size (within ± ⅛ in. [3.2 mm]), shape, material, and condition, or acoustically similar material. The position and amplitude of the response from each notch shall be marked on the instrument screen or a transparent overlay, and these marks shall be used as the evaluation reference. Indications that appear between these points shall be evaluated on the basis of a straight line joining the two peak amplitudes.

S3.2 *Longitudinal Wave*—The longitudinal wave test shall be calibrated on a flat-bottomed reference hole of a given diameter in accordance with Table S5.1 for specified material thickness drilled either into the piece to be tested or into a separate defect-free specimen of the same size (within ± ⅛ in. [3.2 mm]), shape, material, and condition or acoustically similar material. Holes are to be drilled to midsection and the bottom of the hole shall be parallel to the entrant surface. The ultrasonic test instrument shall be adjusted so that the response from the reference hole shall not be less than 25 % and not more than 75 % of screen height.

S3.3 *Recalibration*—During quality conformance inspection, any realignment of the search unit that will cause a decrease in the calibrated sensitivity and resolution, or both, or any change in search unit, couplant, instrument settings, or scanning speed from that used for calibration shall require recalibration. Recalibration shall be performed at least once per 8 h shift.

S4. *Procedure:*

S4.1 *Ring and Hollow Round Products*—Rings and other hollow cylindrical products shall be tested using the shear wave method by the contact or immersion technique. The shear wave entrant angle shall be such as to ensure reflection from the notch or notches used in calibration. For contact testing, the search unit shall be fitted with a wedge or shoe machined to fit the curvature of the piece being inspected. The product also shall be inspected with a longitudinal wave test from the external circumferential and end surfaces.

S4.2 *Disk or Pancake Forgings*—Disk or pancake forgings shall be inspected with a longitudinal wave technique from both parallel surfaces.

**TABLE S5.1 Ultrasonic Testing Reference Hole for Rod, Bar, Disk Pancake Forgings, and Forgings**

Material Thickness, in. [mm]	Hole Diameter, in. [mm]
Up to and including 6 [152]	⅛ [3.2]
Over 6 [152] and including 16 [406]	¼ [6.4]
Over 16 [406]	As agreed upon

S5. *Acceptance Criteria:*

S5.1 *Shear Wave*—Any material that produces indications equal to or larger than the response from the reference notch or higher than the straight line joining the two peak amplitudes shall be rejected.

S5.2 *Longitudinal Wave*—Any material that produces indications equal to or larger than the response from the reference hole or that produces a complete loss of back reflection shall be rejected. Material shall be tested using a square, rectangular, or circular transducer having an effective area of 1 in.<sup>2</sup> or less, but

no dimension shall be smaller than the diameter of the reference hole. In the event of disagreement on the degree of back reflection loss, it shall be determined by the contact method using a 1 in. to 1 $\frac{1}{8}$  in. [25.4 mm to 28.6 mm] diameter transducer or one whose area falls within this range.

S5.3 *Reference Notch Removal*—If reference notches or flat-bottomed holes are made in the material to be tested, they shall be so located that their subsequent removal will not impair the suitability of the material for its intended use.

## APPENDIXES

(Nonmandatory Information)

### X1. NOMINAL COMPOSITION AND RELATIVE FORGEABILITY RATINGS

X1.1 The nominal compositions of the various forging materials are shown in Table X1.1.

ASME BPVC Section II Part B) 2025  
ASMENORMDOC.COM : Click to view the full PDF of ASME BPVC.II.B

TABLE X1.1 Nominal Compositions and Relative Forgeability Ratings

Copper or Copper Alloy UNS or EN 1412 No.	Nominal Composition, %														Relative Forgeability Rating <sup>A</sup>
	Copper	Lead	Tin	Iron	Nickel	Aluminum	Silicon	Manganese	Zinc	Sulfur	Tellurium	Phosphorus	Arsenic	Bismuth	
C11000	100	...	...	...	...	...	...	...	...	...	...	...	...	...	65
C14500	99.45	...	...	...	...	...	...	...	...	...	0.55	...	...	...	65
C14700	99.5	...	...	...	...	...	...	...	...	0.35	...	...	...	...	65
C27450	62.5	0.12	...	...	...	...	...	...	37.4	...	...	...	...	...	95
C27451	61.0–65.0	0.12	...	...	...	...	...	...	36.8	...	...	0.05–0.20	...	...	95
C27453	62.5	...	...	...	...	...	...	...	...	...	...	...	0.8	...	90
C28500	58.0	0.10	...	0.30	...	...	...	...	41.0	...	...	...	...	...	100
C35330	61.7	2.5	...	...	...	...	...	...	35.7	...	...	...	0.13	...	95
C36300	62	0.5	...	...	...	...	...	...	37.5	...	...	0.09	...	...	95
C36500	60	0.6	...	...	...	...	...	...	39.4	...	...	...	...	...	100
C37000	60	1	...	...	...	...	...	...	39	...	...	...	...	...	100
C37700	60	2	...	...	...	...	...	...	38	...	...	...	...	...	100
C46400	60	...	0.8	...	...	...	...	...	39.2	...	...	...	...	...	90
C46500	60.0	0.10	0.8	0.05	...	...	...	...	38.9	...	...	...	0.04	...	90
C46750	60.9	...	1.4	...	...	...	...	...	37	...	...	0.1	...	...	95
C48200	60	0.7	0.8	...	...	...	...	...	38.5	...	...	...	...	...	90
C48500	60	1.8	0.8	...	...	...	...	...	37.4	...	...	...	...	...	90
C48600	60.5	1.7	0.9	...	...	...	...	...	36.8	...	...	...	0.13	...	90
C48640	60	2	1.2	...	...	...	...	...	34.7	...	...	0.1	...	...	95
C48645	61.5	1.7	0.8	...	...	...	...	...	36	...	...	0.13	...	...	95
C49250	60.0	...	...	...	...	...	...	...	37.9	...	...	...	...	2.2	90
C49255	59	...	...	...	0.2	...	...	...	38.5	...	...	...	...	2.3	90
C49260	60.5	...	...	...	...	...	...	...	38.3	...	...	...	...	1.1	90
C49265	60.0	0.17	...	...	...	...	...	...	39.0	...	...	0.08	...	0.9	90
C49300	60	...	1.6	...	1	...	...	...	37.3	...	...	...	...	1.2	95
C49340	61.5	...	1	...	...	...	...	...	36.2	...	...	...	...	1.3	90
C49345	62.0	0.17	...	...	...	...	...	...	36.9	...	...	0.08	...	0.9	90
C49350	62	...	2.2	...	...	...	...	...	34.2	...	...	...	...	1.5	95
C49355	66.0	...	1.0	...	...	...	1.5	...	31.0	...	...	...	...	0.7	80
C61900	87.5	...	...	3.5	...	9	...	...	...	...	...	...	...	...	75
C62300	88	...	...	3	...	9	...	...	...	...	...	...	...	...	75
C63000	81	...	...	3	5	10	...	1	...	...	...	...	...	...	75
C63200	81	...	...	4	4.5	9	...	1.5	...	...	...	...	...	...	75
C64200	91	...	...	...	...	7	2	...	...	...	...	...	...	...	75
C64210	91.3	...	...	...	...	6.7	2	...	...	...	...	...	...	...	75
C65500	96	...	...	B	...	...	3	90	B	...	...	...	...	...	40
C65680	87.4	...	...	...	...	...	3.5	0.05	9.0	...	...	0.1	...	...	80
C67500	58.5	...	1	1	...	...	...	0.10	39.4	...	...	...	...	...	80
C67600	58.5	0.75	1	1	...	...	...	0.10	39.6	...	...	...	...	...	80
C69300	75.0	...	...	...	...	...	3.0	...	21.9	...	...	0.10	...	...	95
C69410	83	...	...	...	...	...	4.0	...	13.0	...	...	...	...	...	90
C69850	68.2	...	...	...	...	...	1.75	...	29.9	...	...	0.10	...	...	90
C70620	86.5	...	...	1.4	10.0	...	...	1	...	...	...	...	...	...	75
C71520	65.0	...	...	0.7	31.0	...	...	1	...	...	...	...	...	...	40
C77400	45	...	...	...	10	...	...	...	45	...	...	...	...	...	85
C87700	88.5 min	...	...	...	...	...	3.0	...	8.0	...	...	...	...	...	80
C87710	86.0 min	...	...	...	...	...	4.0	...	10.0	...	...	...	...	...	80
CW612N	60	2	...	...	...	...	...	...	38	...	...	...	...	...	100
CW617N	58	2	...	...	...	...	...	...	40	...	...	...	...	...	100

<sup>A</sup> Relative forgeability rating takes into consideration such variable factors as pressure, die wear, and plasticity (hot). Since it is impracticable to reduce these variables to common units, calibration in terms of a percentage of the most generally used alloy, forging brass (100 %), is considered the most practical basis for such ratings. The values shown represent the general opinion and are intended for information to enable the designer to better understand the forging characteristics of these various alloys. Intricate parts are more likely to be available in alloys having a high rating.

<sup>B</sup> One or more of these elements may be present as specified in Table 2.

X2. DIMENSIONAL TOLERANCES

X2.1 The data in Table X2.1 do not constitute a part of this specification. They are given merely to indicate to the purchaser the various forging types and some dimensional tolerances used on commercially designed hot-pressed forgings up to 2 lb [0.9 kg] in weight. For tolerances applicable to heavier forgings, the manufacturer should be consulted.

X2.2 Mismatch

X2.2.1 The mismatch (*a* in Fig. X2.1) shall be determined with respect to the largest nominal dimension (*w* max in Fig.

X2.1) in the forging direction (see Fig. X2.1) not associated with a particular dimension. Tolerances for dimensions within the die cavity are independently applied.

X2.3 Flatness

X2.3.1 Deviation from flatness may result from distortion, heat treatment, ejection from the mold, or trimming. This deviation is in addition to the tolerances caused by the forging process itself. (See Fig. X2.2.)

TABLE X2.1 Dimensional Tolerances

	Tolerances, Plus and Minus, in. [mm] Except as Indicated <sup>A</sup>			
	Copper or Copper Alloy UNS No. or EN 1412 No.			
	C11000	C27450	C77400	C63000
	C14500	C27451		C63200
	C14700	C27453		C65500
	C61900	C28500		C70620
	C62300	C35330		C71520
	C64200	C36300		C87700
	C64210	C36500		C87710
		C37000		
		C37700		
		C46400		
		C46500		
		C46750		
		C48200		
		C48500		
		C48600		
		C48640		
		C48645		
		C49250		
		C49260		
		C49265		
		C49300		
		C49340		
		C49345		
		C49350		
		C49355		
		C65680		
		C67500		
		C67600		
		C69300		
		C69410		
		C69850		
		CW612N		
		CW617N		
Forging types:				
Solid	0.010 [0.25]	0.008 [0.20]	0.008 [0.20]	0.012 [0.30]
Solid, with symmetrical cavity	0.010 [0.25]	0.008 [0.20]	0.008 [0.20]	0.012 [0.30]
Solid, with eccentric cavity	0.012 [0.30]	0.008 [0.20]	0.008 [0.20]	0.012 [0.30]
Solid, deep extrusion	0.012 [0.30]	0.010 [0.25]	0.010 [0.25]	0.014 [0.36]
Hollow, deep extrusion	0.012 [0.30]	0.010 [0.25]	0.010 [0.25]	0.014 [0.36]
Thin section, short (up to 6 in. [152 mm] incl.)	0.012 [0.30]	0.010 [0.25]	0.010 [0.25]	0.014 [0.36]
Thin section, long (over 6 in. [152 mm] to 14 in. [356 mm] incl.)	0.015 [0.38]	0.015 [0.38]	0.015 [0.38]	0.020 [0.51]
Thin section, round	0.012 [0.30]	0.010 [0.25]	0.010 [0.25]	0.014 [0.36]
Draft angles, outside and inside 1 to 5°	1/2 °	1/2 °	1/2 °	1/2 °
Machining allowance (on one surface)	1/32 [0.79]	1/32 [0.79]	1/32 [0.79]	1/32 [0.79]
Flatness (maximum deviation per inch [per 25.4 mm])	0.005 [0.13]	0.005 [0.13]	0.005 [0.13]	0.005 [0.13]
Concentricity (total indicator reading)	0.030 [0.76]	0.020 [0.51]	0.030 [0.76]	0.030 [0.76]
Nominal web thickness:	5/32 [4.0]	1/8 [3.2]	1/8 [3.2]	3/16 [4.8]
Tolerance	1/64 [0.40]	1/64 [0.40]	1/64 [0.40]	1/64 [0.40]
Nominal fillet and radius:	3/32 [2.4]	1/16 [1.6]	1/16 [1.6]	1/8 [3.2]
Tolerance	1/64 [0.40]	1/64 [0.40]	1/64 [0.40]	1/64 [0.40]
Approximate flash thickness	1/16 [1.6]	3/64 [1.2]	3/64 [1.2]	5/64 [2.0]

<sup>A</sup> If tolerances all plus or all minus are desired, double the values given.

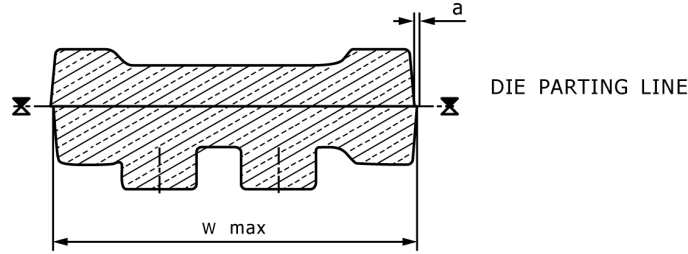

FIG. X2.1 Mismatch at Die Parting Line

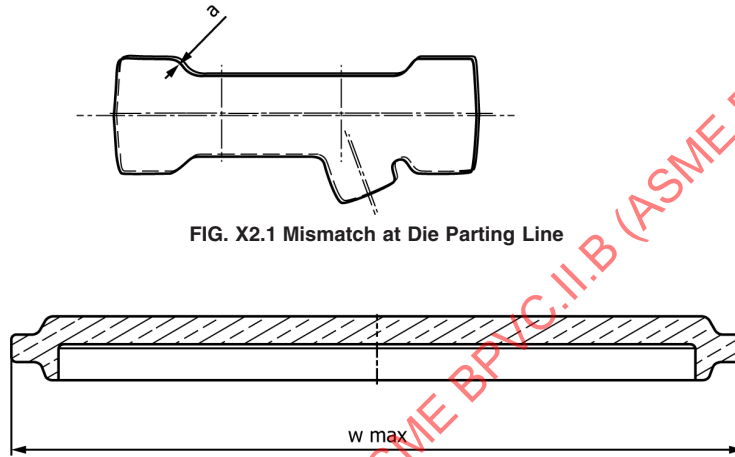

FIG. X2.2 Deviation from Flatness

X2.3.2 The flatness shall be determined with respect to the largest nominal dimension ( $w_{max}$  in Fig. X2.2), in the forging direction, and applied independent of the tolerances for form or position.

**X2.4 Ejector Marks**

X2.4.1 Ejectors may be necessary in the forging process to eject the forging from the die cavity. Ejector marks may be raised or indented. When an ejector mark is either fully raised or fully indented, the full range of the tolerance applies. For example, if the tolerance is  $\pm 0.0118$  in. [0.3 mm], the ejector mark may be raised up or indented to 0.0236 in. [0.6 mm]. (See Fig. X2.3.)

**X2.5 Flash Projection**

X2.5.1 The flash projection ( $2$  in Fig. X2.4) is determined from the largest nominal dimension, ( $w_{max}$  in Fig. X2.1), perpendicular to the forging direction.

X2.5.2 The flash on the die parting line shall be removed by trimming. (See Fig. X2.4.)

X2.5.3 Other flashes generated from operations such as punching, piercing, or left by die-inserts, are permissible if removed during machining, or not detrimental to the finished part. Permissible flash should be indicated on the product drawing, but should not exceed 0.059 in. [1.5 mm].

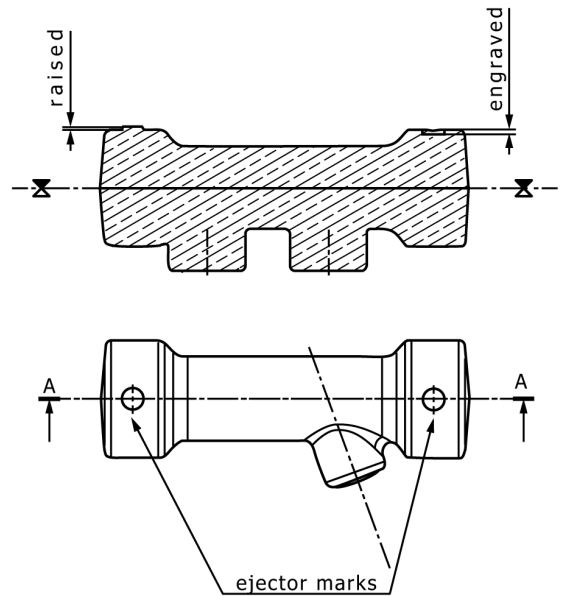

FIG. X2.3 Ejector Marks

X2.5.4 Flash projection applies independently from dimensional tolerances.

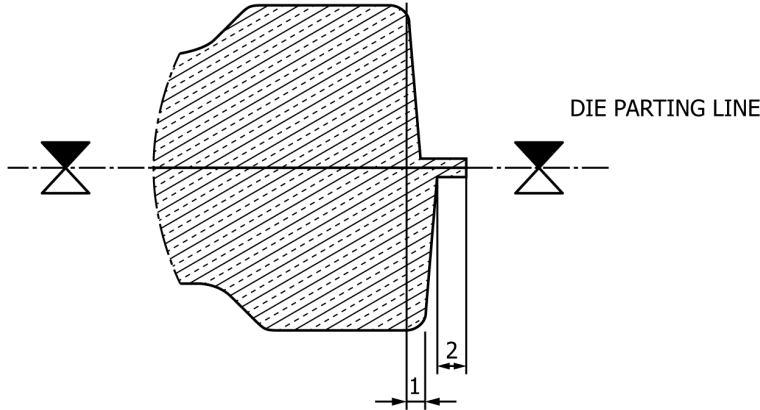

FIG. X2.4 Flash Projection

**X2.6 Area**

X2.6.1 The area A shall be determined as follows:

X2.6.1.1 For round parts, the area shall be equal to the area of the circumscribed circle.

X2.6.1.2 For irregular shapes, the area shall be calculated by the area of the circumscribed rectangle ( $A = W_{max} \times W$ ). (See Fig. X2.5.)

**X2.7 Die Parting Line**

X2.7.1 The parting line is the line identifying the matching flats of the two half dies.

X2.7.2 The flatness shall be determined in regards to the largest nominal dimension ( $w_{max}$ ), in the forging direction, and applied independently from all tolerances of form or position.



FIG. X2.6 Die Parting Line

X2.7.3 The mismatch shall be determined in regards to the largest nominal dimension ( $w_{max}$ ), in the forging direction, not associated to a particular direction. (See Fig. X2.6.)

**X2.8 Angular Tolerances**

X2.8.1 Table X2.2 and Fig. X2.7 provide guidelines for angular tolerance.

**X2.9 Polygonal Shapes Tolerances**

X2.9.1 Refer to Table X2.3 for guidelines for polygonal shapes tolerances.

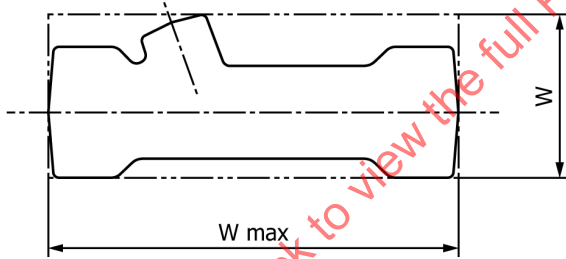

**AREA A =  $W_{max} \times W$**

FIG. X2.5 Area

TABLE X2.2 Angular Tolerances

Nominal Dimension, $W_1$ (length) of Shorter Leg Over in. [mm]	Up to Including in. [mm]	Ref. Fig. X2.7 Angular Tolerance $\alpha^\circ$
...	0.787 [20]	$\pm 2^\circ$
0.787 [20]	1.575 [40]	$\pm 1^\circ$
1.575 [40]	2.362 [60]	$\pm 1^\circ$
2.362 [60]	3.937 [100]	$\pm 0^\circ 30'$
3.937 [100]	7.874 [200]	$\pm 0^\circ 30'$
7.874 [200]	11.811 [300]	$\pm 0^\circ 25'$

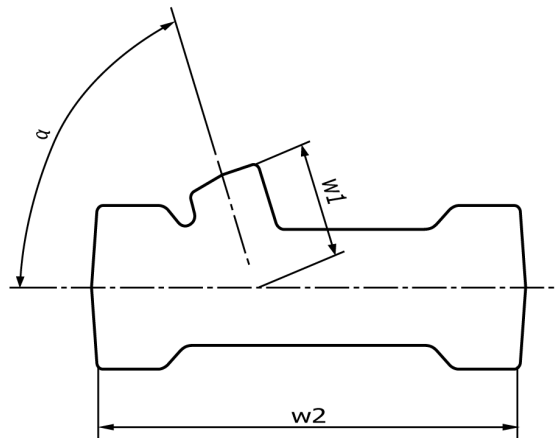

FIG. X2.7 Shorter Leg Example for Angular Tolerances

TABLE X2.3 Polygonal Shapes Tolerances

Nominal Dimension Over in. [mm]	Up to Including in. [mm]	Dimensional Tolerance in. [mm]	
		+	-
...	0.394 [10]	+ 0	+ [0]
		- 0.008	- [0.2]
0.394 [10]	0.984 [25]	+ 0	+ [0]
		- 0.012	- [0.3]
0.984 [25]	1.969 [50]	+ 0	+ [0]
		- 0.016	- [0.4]
1.969 [50]	3.150 [80]	+ 0	+ [0]
		- 0.020	- [0.5]
3.150 [80]	3.937 [100]	+ 0	+ [0]
		- 0.024	- [0.6]
3.937 [100]	4.724 [120]	+ 0	+ [0]
		- 0.028	- [0.7]

### X3. TYPICAL MECHANICAL PROPERTIES

X3.1 Mechanical properties of any forging are influenced by shape and size. Unless otherwise specified in the purchase order or specifically guaranteed by the manufacturer, acceptance of forgings under this specification shall not depend on the mechanical properties determined by tension or hardness

tests. (Frequently, the design of forgings will not permit adequate test sections.) Therefore, the data in Table X3.1 do not constitute a part of this specification, and are given for general information only. They are typical of forgings up to 2 lb [0.9 kg] in weight.

TABLE X3.1 Typical Mechanical Properties of Forgings as Hot Pressed, Temper M10, M11, or TQ50<sup>A</sup>

Copper or Copper Alloy UNS No. or EN 1412 No.	0.505 in. [128 mm] Diameter Test Section					Rockwell Hardness (Filed Surface, 1/8 in. [3.2 mm] Chord, min)	
	Tensile Strength		Yield Strength (0.5 % Extension Under Load)		Elongation in 4 × Diameter, %	F Scale	B Scale
	ksi	[MPa] <sup>B</sup>	ksi	[MPa] <sup>B</sup>			
C11000	33	[230]	11	[75]	40	37	...
C14500	34	[235]	12	[85]	35	40	...
C14700	34	[235]	12	[85]	35	40	...
C27450	56	[386]	26	[180]	46	...	46
C27451	56	[386]	26	[180]	46	...	46
C27453	52	[360]	35	[240]	30	...	70
C28500	66	[455]	28	[190]	25	...	72
C35330	58	[400]	23	[160]	40	...	45
C36300	56	[386]	26	[180]	46	...	46
C36500	58	[400]	23	[160]	40	...	45
C37000	58	[400]	23	[160]	40	...	45
C37700	58	[400]	23	[160]	40	...	45
C46400	64	[440]	26	[180]	40	...	55
C46500	63	[435]	30	[207]	40	...	58
C46750	59.5	[410]	29.0	[200]	20	...	55
C48200	64	[440]	26	[180]	40	...	55
C48500	62	[425]	24	[165]	40	...	55
C48600	62	[425]	24	[165]	40	...	55
C48640	58	[400]	29	[200]	30	...	55
C48645	58	[400]	29	[200]	30	...	55
C49250	62	[425]	24	[165]	40	...	55
C49260	62	[425]	24	[165]	40	...	55
C49265	62	[425]	24	[165]	40	...	55
C49300	62	[425]	24	[165]	40	...	55
C49340	60	[415]	22	[150]	35	...	50
C49345	60	[415]	22	[150]	35	...	50
C49350	60	[415]	22	[150]	35	...	50
C49355	64	[443]	36	[250]	17	...	84
C61900	82	[565]	37	[255]	32	...	82
C62300	82	[565]	37	[255]	32	...	82
C63000	95	[655]	48	[330]	15	...	90
C63200	92	[635]	45	[310]	18	...	88
C64200	83	[570]	41	[285]	35	...	77
C64210	83	[570]	41	[285]	35	...	77
C65500	52	[360]	18	[125]	70	...	62
C65680	61	[420]	36	[250]	10	...	63
C67500	72	[495]	34	[235]	33	...	69
C67600	72	[495]	34	[235]	33	...	69
C69300	80	[550]	41	[285]	28	...	78
C69410	55	[380]	20	[138]	40	...	75
C69850	65	[448]	30	[207]	22	...	55
C71520	55	[380]	20	[138]	45	...	35
C77400	83	[570]	36	[250]	25	...	73
C87700	55	[380]	20	[138]	40	...	75
C87710	57	[393]	26	[180]	19	...	72
CW612N	58	[400]	23	[160]	40	...	45
CW617N	58	[400]	23	[160]	40	...	45

<sup>A</sup> For Copper Alloy UNS Nos. C63000 and C63200.

<sup>B</sup> See Appendix X5.

## X4. GUIDELINES FOR FORGINGS DESIGN AND DEVELOPMENT

### INTRODUCTION

The following guidelines are provided for the design and development of forgings, including die design.

#### X4.1 Draft Angles

X4.1.1 To allow an easy ejection of forgings (areas lying in the forging direction) from the die, draft angles are necessary. It is suggested to use as a best practice the following draft angles. See also Fig. X4.1.

External areas 30°  
Internal areas 1°

X4.1.2 Smaller or greater draft angles may be adopted according to particular needs or cases.

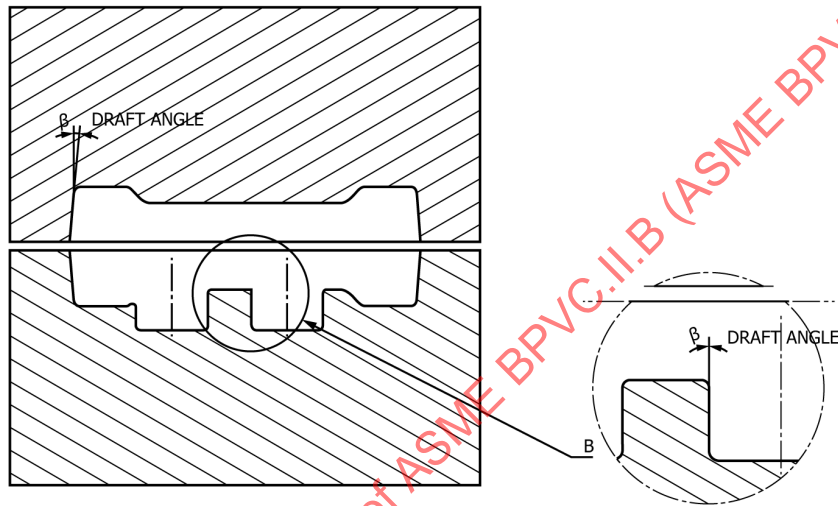

FIG. X4.1 Draft Angles in Example Forging Die

### X5. METRIC EQUIVALENTS

X5.1 The SI unit for strength properties now shown is in accordance with the International System of Units (SI). The derived SI unit for force is the newton (N), which is defined as that force which when applied to a body having a mass of one kilogram gives it an acceleration of one metre per second squared ( $N = \text{kg} \cdot \text{m}/\text{s}^2$ ). The derived SI unit for pressure or

stress is the newton per square metre ( $\text{N}/\text{m}^2$ ), which has been named the pascal (Pa) by the General Conference on Weights and Measures. Since  $1 \text{ ksi} = 6\,894\,757 \text{ Pa}$ , the metric equivalents are expressed as megapascal (MPa), which is the same as  $\text{MN}/\text{m}^2$  and  $\text{N}/\text{mm}^2$ .

## SUMMARY OF CHANGES

Committee B05 has identified the location of selected changes to this standard since the last issue (B283/B283M – 20) that may impact the use of this standard. (Approved Oct. 1, 2022.)

- (1) Removed former 8.1.2; M11 not mentioned in specification.      (2) Removed former 8.2 and 8.2.1; incorporated in 10.2.  
(3) Added UNS Alloy No. C63000 to 10.1.

*ASTM International takes no position respecting the validity of any patent rights asserted in connection with any item mentioned in this standard. Users of this standard are expressly advised that determination of the validity of any such patent rights, and the risk of infringement of such rights, are entirely their own responsibility.*

*This standard is subject to revision at any time by the responsible technical committee and must be reviewed every five years and if not revised, either reapproved or withdrawn. Your comments are invited either for revision of this standard or for additional standards and should be addressed to ASTM International Headquarters. Your comments will receive careful consideration at a meeting of the responsible technical committee, which you may attend. If you feel that your comments have not received a fair hearing you should make your views known to the ASTM Committee on Standards, at the address shown below.*

*This standard is copyrighted by ASTM International, 100 Barr Harbor Drive, PO Box C700, West Conshohocken, PA 19428-2959, United States. Individual reprints (single or multiple copies) of this standard may be obtained by contacting ASTM at the above address or at 610-832-9585 (phone), 610-832-9555 (fax), or service@astm.org (e-mail); or through the ASTM website (www.astm.org). Permission rights to photocopy the standard may also be secured from the Copyright Clearance Center, 222 Rosewood Drive, Danvers, MA 01923, Tel: (978) 646-2600; <http://www.copyright.com/>*

# SPECIFICATION FOR ALUMINUM-ALLOY 6061-T6 STANDARD STRUCTURAL PROFILES



**SB-308/SB-308M**

(Identical with ASTM Specification B308/B308M-20 except that certification and a test report have been made mandatory.)

ASMENORMDOC.COM : Click to view the full PDF of ASME BPVC.II.B (ASME BPVC Section II part B) 2025

# Specification for Aluminum-Alloy 6061-T6 Standard Structural Profiles

## 1. Scope

1.1 This specification covers extruded 6061-T6 aluminum-alloy standard structural profiles.

1.2 The profiles are limited to I-beams, H-beams, channels, angles, tees, and zees.

NOTE 1—For other extruded profiles in other alloys and tempers refer to Specification B221.

1.3 Alloy and temper designations are in accordance with ANSI H35.1/H35.1(M). The equivalent Unified Numbering System alloy designation is that in Table 1 preceded by A9, or A96061 for alloy 6061 in accordance with Practice E527.

1.4 For acceptance criteria for inclusion of new aluminum and aluminum alloys in this specification, see Annex A2.

1.5 The values stated in either SI units or inch-pound units are to be regarded separately as standard. The values stated in each system may not be exact equivalents; therefore, each system shall be used independently of the other. Combining values from the two systems may result in non-conformance with the standard.

1.6 *This standard does not purport to address all of the safety concerns, if any, associated with its use. It is the responsibility of the user of this standard to establish appropriate safety, health, and environmental practices and determine the applicability of regulatory limitations prior to use.*

1.7 *This international standard was developed in accordance with internationally recognized principles on standardization established in the Decision on Principles for the Development of International Standards, Guides and Recommendations issued by the World Trade Organization Technical Barriers to Trade (TBT) Committee.*

## 2. Referenced Documents

2.1 The following documents of the issue in effect on the date of material purchase form a part of this specification to the extent referenced herein:

### 2.2 ASTM Standards:

- B221 Specification for Aluminum and Aluminum-Alloy Extruded Bars, Rods, Wire, Profiles, and Tubes
- B557 Test Methods for Tension Testing Wrought and Cast Aluminum- and Magnesium-Alloy Products
- B557M Test Methods for Tension Testing Wrought and Cast Aluminum- and Magnesium-Alloy Products (Metric)
- B647 Test Method for Indentation Hardness of Aluminum Alloys by Means of a Webster Hardness Gage
- B648 Test Method for Indentation Hardness of Aluminum Alloys by Means of a Barcol Impressor
- B660 Practices for Packaging/Packing of Aluminum and Magnesium Products
- B666/B666M Practice for Identification Marking of Aluminum and Magnesium Products
- B807/B807M Practice for Extrusion Press Solution Heat Treatment for Aluminum Alloys
- B881 Terminology Relating to Aluminum- and Magnesium-Alloy Products
- B918 Practice for Heat Treatment of Wrought Aluminum Alloys
- B985 Practice for Sampling Aluminum Ingots, Billets, Castings and Finished or Semi-Finished Wrought Aluminum Products for Compositional Analysis
- D3951 Practice for Commercial Packaging
- E18 Test Methods for Rockwell Hardness of Metallic Materials
- E29 Practice for Using Significant Digits in Test Data to Determine Conformance with Specifications
- E527 Practice for Numbering Metals and Alloys in the Unified Numbering System (UNS)

- E607 Test Method for Atomic Emission Spectrometric Analysis Aluminum Alloys by the Point to Plane Technique Nitrogen Atmosphere (Withdrawn 2011)
- E716 Practices for Sampling and Sample Preparation of Aluminum and Aluminum Alloys for Determination of Chemical Composition by Spark Atomic Emission Spectrometry
- E1251 Test Method for Analysis of Aluminum and Aluminum Alloys by Spark Atomic Emission Spectrometry
- E3061 Test Method for Analysis of Aluminum and Aluminum Alloys by Inductively Coupled Plasma Atomic Emission Spectrometry (Performance Based Method)
- 2.3 *ANSI Standards:*
- H35.1/H35.1(M) Alloy and Temper Designation Systems for Aluminum
- H35.2 Dimensional Tolerances for Aluminum Mill Products
- H35.2(M) Dimensional Tolerances for Aluminum Mill Products (Metric)
- 2.4 *Federal Standard:*
- Fed. Std. No. 123 Marking for Shipment (Civil Agencies)
- 2.5 *AMS Specifications:*
- AMS 2772 Heat Treatment of Aluminum Alloy/Raw Materials
- 2.6 *Military Specifications:*
- MIL-STD-129 Marking for Shipment and Storage
- 2.7 *CEN EN Standards:*
- EN 14242 Aluminum and aluminum alloys, Chemical analysis inductively coupled plasma optical emission spectral analysis.

### 3. Terminology

3.1 *Definitions*—Refer to Terminology B881 for definitions of product terms used in this specification.

3.2 *Definitions of Terms Specific to This Standard:*

3.2.1 *inspection lot*—an identifiable quantity of material of the same mill form, alloy, temper, and nominal dimensions traceable to a heat-treat lot of lots, subjected to inspection at one time (see 14.1).

3.2.2 *heat-treat lot*—an identifiable quantity of material heat-treated in the same furnace at the same time (see 10.2.1 and 10.2.2).

### 4. Ordering Information

4.1 Orders for material to this specification shall include the following information:

4.1.1 This specification designation (which includes the number, the year, and the revision letter, if applicable),

NOTE 2—For inch-pound orders specify B308; for metric orders specify B308M. Do not mix units.

4.1.2 Quantity in pieces or pounds [kilograms],

4.1.3 Alloy (Section 8),

4.1.4 Temper (10.1 and Table 2),

4.1.5 Type of section (1.2), dimensions (including a drawing if necessary), and length,

4.2 Additionally, orders for material to this specification shall include the following information when required by the purchaser:

4.2.1 Whether solution heat treatment at the extrusion press is unacceptable (9.2),

4.2.2 Whether heat treatment in accordance with Practice B918 is required (9.3),

4.2.3 Whether inspection or witness of inspection and tests by the purchaser's representative is required prior to material shipment (Section 13),

4.2.4 DELETED

4.2.5 Whether marking for identification is required (16.1), and

4.2.6 Whether Practices B660 applies and, if so, the applicable levels of preservation, packaging, and packing required (17.3).Table 2

### 5. Materials and Manufacture

5.1 The products covered by this specification shall be produced by hot extruding only.

TABLE 1 Chemical Composition Limits<sup>A,B,C,F</sup>

Alloy 6061	Composition, %
Silicon	0.40–0.8
Iron	0.7
Copper	0.15–0.40
Manganese	0.15
Magnesium	0.8–1.2
Chromium	0.04–0.35
Zinc	0.25
Titanium	0.15
Other elements <sup>D</sup> each	0.05
Total <sup>E</sup>	0.15
Aluminum	rem

<sup>A</sup> Where single units are shown, these indicate the maximum amounts permitted.

<sup>B</sup> Analysis shall be made for the elements for which limits are shown in this table.

<sup>C</sup> For purposes of determining conformance to these limits, an observed value or a calculated value obtained from analysis shall be rounded to the nearest unit in the last right-hand place of figures used in expressing the specified limit, in accordance with the rounding-off method of Practice E29.

<sup>D</sup> *Others* includes all unlisted metallic elements. The producer may analyze samples for trace elements not specified in the specification. However, such analysis is not required and may not cover all metallic *Others* elements. Should any analysis by the producer or the purchaser establish that an *Others* element exceeds the limit of *Each* or that the aggregate of several *Others* elements exceeds the limit of *Total*, the material shall be considered nonconforming.

<sup>E</sup> *Other Elements*—Total shall be the sum of unspecified metallic elements 0.010 % or more, rounded to the second decimal before determining the sum.

<sup>F</sup> In case there is a discrepancy in the values listed in Table 1 with those listed in the "International Alloy Designations and Chemical Composition Limits for Wrought Aluminum and Wrought Aluminum Alloys" (known as the "Teal Sheets"), the composition limits registered with the Aluminum Association and published in the "Teal Sheets" shall be considered the controlling composition. The "Teal Sheets" are available at <http://www.aluminum.org/tealsheets>.

TABLE 2 Tensile Property Limits<sup>A,B</sup>

6061-T6	
Tensile strength, min, ksi [MPa]	38.0 [260]
Yield strength, min, ksi [MPa]	35.0 [240]
Elongation, <sup>C</sup> min, %	
in 2 in. [50 mm]	10 [10] <sup>D</sup>
in 4D [5D or 5.65 $\sqrt{A}$ ]	10 [9]

<sup>A</sup> For purposes of determining conformance with this specification, each value for tensile strength and yield strength shall be rounded to the nearest 0.1 ksi [1 MPa], and each value for elongation shall be rounded to the nearest 0.5 %, both in accordance with the rounding method of Practice E29.

<sup>B</sup> The basis for mechanical property limits is given in Annex A1.

<sup>C</sup> Elongations in 2 in. [50 mm] apply for profiles tested in full section and for sheet-type specimens machined from material up through 0.500 in. [12.5 mm] in thickness having parallel surfaces. Elongations in 4D [5D or 5.65  $\sqrt{A}$ ], where D and A are diameter and cross-sectional area of the specimen, respectively, apply to round test specimens machined from thicknesses over 0.250 in. [6.30 mm].

<sup>D</sup> For thicknesses less than 0.250 in. [up through 6.30 mm] the minimum elongation is 8 %.

## 6. Quality Assurance

6.1 *Responsibility for Inspection and Tests*—Unless otherwise specified in the contract or purchase order, the producer is responsible for the performance of all inspection and test requirements specified herein. The producer may use his own or any other suitable facilities for the performance of the inspection and test requirements specified herein, unless disapproved by the purchaser in the order or at the time of contract signing. The purchaser shall have the right to perform any of the inspections and tests set forth in this specification where such inspections are deemed necessary to ensure that material conforms to prescribed requirements.

## 7. General Quality

7.1 Unless otherwise specified, the structural profiles shall be supplied in the mill finish and shall be uniform as defined by the requirements of this specification and shall be commercially sound. Any requirement not so covered is subject to negotiation between the producer and purchaser.

7.2 Each profile shall be examined to determine conformance to this specification with respect to general quality and identification marking. On approval of the purchaser, however, the producer or the supplier may use a system of statistical quality control for such examination.

## 8. Chemical Composition

8.1 *Limits*—The material shall conform to the chemical composition limits specified in Table 1. Conformance shall be determined by the producer by taking samples in accordance with E716 when the ingots are poured, and analyzing those samples in accordance with E607, E1251, E3061, or EN 14242. At least one sample shall be taken for each group of ingots poured simultaneously from the same source of molten metal. If the producer has determined the chemical composition during pouring of the ingots, they shall not be required to sample and analyze the finished product.

8.2 If it becomes necessary to analyze an extrusion for conformance to chemical composition limits, the methods of sampling and methods of analysis shall be as provided in the following:

8.2.1 *Methods of Sampling*—Samples for chemical analysis shall be taken in accordance with Practice B985.

8.2.2 *Methods of Analysis*—Analysis shall be performed in accordance with Test Methods E607, E1251, E3061, or EN 14242.

8.3 Other methods of analysis or in the case of dispute may be by agreement between the producer and the purchaser.

NOTE 3—It is standard practice in the United States aluminum industry to determine conformance to the chemical composition limits prior to further processing of ingots into wrought products. Due to the continuous nature of the process, it is not practical to keep a specific ingot analysis identified with a specific quantity of finished material.

## 9. Heat Treatment

9.1 Except as noted in 9.2, or otherwise specified in 9.3, producer or supplier heat treatment shall be in accordance with AMS 2772.

9.2 Unless otherwise specified, material may be solution heat-treated and quenched at the extrusion press in accordance with Practice B807/B807M.

9.3 When specified, heat treatment shall be in accordance with Practice B918.

## 10. Tensile Properties

10.1 *Limits*—The structural profiles shall conform to the tensile requirements specified in Table 2.

10.1.1 The elongation requirements shall not be applicable to the following:

10.1.1.1 Material of such dimensions that a standard test specimen cannot be taken in accordance with Test Methods B557 or B557M and of such profile that it cannot be satisfactorily tested in full section.

10.1.1.2 Material less than 0.062 in. [up through 1.60 mm] in thickness.

### 10.2 Number of Specimens:

10.2.1 For material having a nominal weight of less than 1 lb/linear ft [up through 1.7 kg/linear m], one tension test specimen shall be taken for each 1000 lb [500 kg] or fraction thereof in the heat-treat lot.

10.2.2 For material having a nominal weight of 1 lb or more/linear ft [over 1.7 kg/linear m], one tension test specimen shall be taken for each 1000 ft [300 m] or fraction thereof in the heat-treat lot.

10.2.3 Other procedures for selecting samples may be employed if agreed upon by the producer and the purchaser.

### 10.3 Test Specimens:

10.3.1 *Tension Specimens*—Tension test specimens shall conform to Test Methods B557 or B557M.

### 10.4 Test Method:

10.4.1 *Tension Tests*—The tension test shall be made in accordance with Test Methods B557 or B557M.

## 11. Quality Assurance Screening of Extrusion Press Heat-Treated Shapes

11.1 For 6061-T6 shapes that are manufactured by quenching at the extrusion press, the requirements of this section shall

apply in addition to all other applicable requirements of this specification. Hardness tests shall be performed either on each extruded charge or on a sample selected in accordance with a sampling plan as specified on purchase orders. The minimum hardness control value shall be in accordance with Table 3 for the type of hardness tester used. The specific type of hardness tester used shall be the producer's choice. The test shall be conducted in accordance with the applicable hardness test standard, namely Test Method B647 for Webster hardness, Test Method B648 for Barcol hardness, or Test Methods E18 for Rockwell E hardness.

11.2 Individual extruded charges that fail to conform to the requirements of Table 3 may be accepted provided the two pieces in the lot having the two lowest hardness readings are tension-tested and found to conform to the requirements of Table 2.

## 12. Dimensional Tolerances

12.1 Unless otherwise specified, structural profiles ordered to this specification shall meet the requirements of ANSI H35.2/H35.2(M).

## 13. Source Inspection

13.1 If the purchaser desires that his representative inspect or witness the inspection and testing of the material prior to shipment, such agreement shall be made by the purchaser and producer as part of the purchase contract.

13.2 When such inspection or witness of inspection and testing is agreed upon, the producer shall afford the purchaser's representative all reasonable facilities to satisfy him that the material meets the requirements of this specification. Inspection and tests shall be conducted so there is no unnecessary interference with the producer's operations.

**TABLE 3 Hardness Screening Values<sup>A,B,C</sup>**

Thickness		Hardness Number, min		
in.	mm	Webster	Barcol	Rockwell E
0.050 through 0.075	over 1.20 through 2.00	15	76	89
0.076 through 0.499	over 2.00 through 12.50	15	76	90
0.500 and over	over 12.50	...	76	...

<sup>A</sup> See Section 11.

<sup>B</sup> Alternate minimum hardness values and hardness testing devices may be used provided that agreement is reached between the purchaser and the supplier or producer.

<sup>C</sup> The hardness values shown do not guarantee material will pass the applicable mechanical property requirements but are for informational purposes only. It is the responsibility of the user of this specification to establish the relationship between the hardness values and tensile properties.

## 14. Rejection and Retest

14.1 If any material fails to conform to all of the applicable requirements of this specification, it shall be cause for rejection of the inspection lot.

14.2 When there is evidence that a failed specimen was not representative of the inspection lot and when no other sampling plan is provided or approved by the purchaser through the contract or purchase order, retesting may be performed in accordance with Section 9 of Test Methods B557 and B557M.

14.3 Material in which defects are discovered subsequent to inspection may be rejected.

14.4 If material is rejected by the purchaser, the producer or supplier is responsible only for replacement of the material to the purchaser. As much as possible of the rejected material shall be returned to the producer or supplier.

## 15. Certification

15.1 The producer or supplier shall furnish to the purchaser a certificate stating that each lot has been sampled, tested, and inspected in accordance with this specification, and has met the requirements. A report of the test results shall be furnished.

## 16. Identification Marking of Product

16.1 When marking for identification is required (see 4.2.5), all material shall be marked in accordance with Practice B666/B666M.

## 17. Packaging and Package Marking

17.1 The material shall be packaged to provide adequate protection during normal handling and transportation, and each package shall contain only one size, alloy, and temper of material unless otherwise agreed upon. The type of packaging and gross weight of containers shall, unless otherwise agreed upon, be at the producer's discretion, provided that they are such as to ensure acceptance by common or other carriers for safe transportation at the lowest rate to the delivery point.

17.2 Each shipping container shall be marked with the purchase order number, material size, specification number, alloy and temper, gross and net weights, and the producer's name or trademark.

17.3 When specified in the contract or purchase order, material shall be preserved, packaged, and packed in accordance with the requirements of Practices B660. The applicable levels shall be as specified in the contract or order. Marking for shipment of such material shall be in accordance with Fed. Std. No. 123 and Practice D3951 for civil agencies and MIL-STD-129 for military agencies.

## 18. Keywords

18.1 aluminum alloy; standard structural profiles

## ANNEXES

## (Mandatory Information)

## A1. BASIS FOR INCLUSION OF PROPERTY LIMITS

A1.1 Mechanical property limits are established in accord with Section 6, Standards Section, of the most current edition of the Aluminum Standards and Data and the latest edition of the Aluminum Association publication “Tempers for Aluminum and Aluminum Alloy Products (Yellow and Tan Sheets)”.

A1.1.1 Limits are based on a statistical evaluation of the data indicating that at least 99 % of the population obtained from all standard material meets the limit with 95 % confidence. For the products described, mechanical property limits are based on the statistical analyses of at least 100 tests from at least 5 cast lots of standard production material with no more than 10 observations from a given heat treat or inspection lot. Mechanical properties limits for press solution heat treated products have specific additional requirements which are provided in the “Tempers for Aluminum and Aluminum Alloy

Products”. All tests are performed in accordance with the appropriate ASTM test methods.

A1.1.2 Limits denoted as “Tentative” by the Aluminum Association may be included. Requirements for tentative property registrations are defined in the latest edition of the Aluminum Association publication “Tempers for Aluminum and Aluminum Alloy Products”. Tentative property limits are established at levels at which at least 99 % of the data conform at a confidence level of 95 %. Tentative property limits, which are subject to revision, shall be based on a statistical analysis of at least 30 tests from at least 3 cast lots of standard production material with no more than 10 observations from a given heat treat or inspection lot. Where tentative property limits are listed, they shall be shown in italics and footnoted as Tentative in the standard.

## A2. ACCEPTANCE CRITERIA FOR INCLUSION OF NEW ALUMINUM AND ALUMINUM ALLOYS IN THIS SPECIFICATION

A2.1 Prior to acceptance for inclusion in this specification, the composition of wrought or cast aluminum or aluminum alloy shall be registered in accordance with ANSI H35.1/H35.1(M). The Aluminum Association<sup>5</sup> holds the Secretariat of ANSI H35 Committee and administers the criteria and procedures for registration.

A2.2 If it is documented that the Aluminum Association could not or would not register a given composition, an alternative procedure and the criteria for acceptance shall be as follows:

A2.2.1 The designation submitted for inclusion does not utilize the same designation system as described in ANSI H35.1/H35.1(M). A designation not in conflict with other designation systems or a trade name is acceptable.

A2.2.2 The aluminum or aluminum alloy has been offered for sale in commercial quantities within the prior twelve months to at least three identifiable users.

A2.2.3 The complete chemical composition limits are submitted.

A2.2.4 The composition is, in the judgment of the responsible subcommittee, significantly different from that of any other aluminum or aluminum alloy already in the specification.

A2.2.5 For codification purposes, an alloying element is any element intentionally added for any purpose other than grain refinement and for which minimum and maximum limits are specified. Unalloyed aluminum contains a minimum of 99.00 % aluminum.

A2.2.6 Standard limits for alloying elements and impurities are expressed to the following decimal places:

Less than 0.001 %	0.000X
0.001 to but less than 0.01 %	0.00X
0.01 to but less than 0.10 %	
Unalloyed aluminum made by a refining process	0.0XX
Alloys and unalloyed aluminum not made by a refining process	0.0X
0.10 through 0.55 %	0.XX
(It is customary to express limits of 0.30 through 0.55 % as 0.X0 or 0.X5.)	
Over 0.55 %	0.X, X.X, etc.
(except that combined Si + Fe limits for 99.00 % minimum aluminum must be expressed as 0.XX or 1.XX)	

A2.2.7 Standard limits for alloying elements and impurities are expressed in the following sequence: Silicon; Iron; Copper; Manganese; Magnesium; Chromium; Nickel; Zinc; Titanium (Note A2.1); Other Elements, Each; Other Elements, Total; Aluminum (Note A2.2).

NOTE A2.1—Additional specified elements having limits are inserted in alphabetical order of their chemical symbols between Titanium and Other Elements, Each or are specified in footnotes.

NOTE A2.2—Aluminum is specified as *minimum* for unalloyed aluminum and as a *remainder* for aluminum alloys.

# SPECIFICATION FOR SEAMLESS COPPER ALLOY PIPE AND TUBE



**SB-315**

(Identical with ASTM Specification B315-19 except that certification and test reports have been made mandatory, and section 9 has been revised to make nondestructive testing required for all tubes.)

# Specification for Seamless Copper Alloy Pipe and Tube

## 1. Scope

1.1 This specification establishes the requirements for seamless, copper alloy pipe and tube in nominal pipe sizes, both regular and extra strong, and seamless tube in straight lengths for general engineering purposes. Pipe and tube are produced in the copper alloy UNS Numbers: C61300, C61400, C63020, C65100, and C65500.

1.2 *Units*—The values stated in inch-pound units are to be regarded as standard. The values given in parentheses are mathematical conversions to SI units that are provided for information only and are not considered standard.

1.3 The following safety caveat pertains only to the test method(s) described in this specification. *This standard does not purport to address all of the safety concerns, if any, associated with its use. It is the responsibility of the user of this standard to establish appropriate safety, health, and environmental practices and determine the applicability of regulatory limitations prior to use.*

1.4 *This international standard was developed in accordance with internationally recognized principles on standardization established in the Decision on Principles for the Development of International Standards, Guides and Recommendations issued by the World Trade Organization Technical Barriers to Trade (TBT) Committee.*

## 2. Referenced Documents

### 2.1 ASTM Standards:

- B36/B36M Specification for Brass Plate, Sheet, Strip, and Rolled Bar
- B96/B96M Specification for Copper-Silicon Alloy Plate,

Sheet, Strip, and Rolled Bar for General Purposes and Pressure Vessels

B121/B121M Specification for Leaded Brass Plate, Sheet, Strip, and Rolled Bar

B122/B122M Specification for Copper-Nickel-Tin Alloy, Copper-Nickel-Zinc Alloy (Nickel Silver), and Copper-Nickel Alloy Plate, Sheet, Strip, and Rolled Bar

B152/B152M Specification for Copper Sheet, Strip, Plate, and Rolled Bar

B169/B169M Specification for Aluminum Bronze Sheet, Strip, and Rolled Bar

B194 Specification for Copper-Beryllium Alloy Plate, Sheet, Strip, and Rolled Bar

B422/B422M Specification for Copper-Aluminum-Silicon-Cobalt Alloy, Copper-Nickel-Silicon-Magnesium Alloy, Copper-Nickel-Silicon Alloy, Copper-Nickel-Aluminum-Magnesium Alloy, and Copper-Nickel-Tin Alloy Sheet and Strip

B465 Specification for Copper-Iron Alloy Plate, Sheet, Strip, and Rolled Bar

B534 Specification for Copper-Cobalt-Beryllium Alloy and Copper-Nickel-Beryllium Alloy Plate, Sheet, Strip, and Rolled Bar

B591 Specification for Copper-Zinc-Tin and Copper-Zinc-Tin-Iron-Nickel Alloys Plate, Sheet, Strip, and Rolled Bar

B592 Specification for Copper-Zinc-Aluminum-Cobalt Alloy, Copper-Zinc-Tin-Iron Alloy Plate, Sheet, Strip, and Rolled Bar

B740 Specification for Copper-Nickel-Tin Spinodal Alloy Strip

B747 Specification for Copper-Zirconium Alloy Sheet and Strip

B768 Specification for Copper-Cobalt-Beryllium Alloy and Copper-Nickel-Beryllium Alloy Strip and Sheet

B846 Terminology for Copper and Copper Alloys

B888/B888M Specification for Copper Alloy Strip for Use in Manufacture of Electrical Connectors or Spring Contacts

E8/E8M Test Methods for Tension Testing of Metallic Materials

E18 Test Methods for Rockwell Hardness of Metallic Materials

- E29 Practice for Using Significant Digits in Test Data to Determine Conformance with Specifications
- E54 Test Methods for Chemical Analysis of Special Brasses and Bronzes (Withdrawn 2002)
- E62 Test Methods for Chemical Analysis of Copper and Copper Alloys (Photometric Methods) (Withdrawn 2010)
- E243 Practice for Electromagnetic (Eddy Current) Examination of Copper and Copper-Alloy Tubes
- E255 Practice for Sampling Copper and Copper Alloys for the Determination of Chemical Composition
- E478 Test Methods for Chemical Analysis of Copper Alloys
- 2.2 ASME Standard:  
ASME Boiler and Pressure Vessel Code

**3. Terminology**

3.1 For definitions of terms related to copper and copper alloys refer to Terminology B846.

3.2 *Definitions of Terms Specific to This Standard:*

3.2.1 *specially cleaned*—sufficiently free of oxides as to exhibit the golden color associated with the alloy.

**4. Ordering Information**

4.1 Include the following specified choices when placing orders for product under this specification, as applicable:

- 4.1.1 ASTM Designation and year of issue (for example B315 – XX),
- 4.1.2 Copper [Alloy] UNS No. (Section 6, Table 1),
  - 4.1.2.1 Whether the product of copper alloy C61300 is to be subsequently welded (see Table 1 and Footnote A),
- 4.1.3 Temper (Section 7),
- 4.1.4 *Dimensions, Diameter, and Wall Thickness:*
  - 4.1.4.1 Pipe size, regular (Table 3);
  - 4.1.4.2 Pipe size, extra-strong (Table 3);
  - 4.1.4.3 Tube diameter (Table 9);
  - 4.1.4.4 Tube wall thickness (Table 6, Table 7, or Table 8);
  - 4.1.4.5 Length (Table 10 or Table 11);

4.1.4.6 When copper alloy UNS No. C63020 is ordered under this specification, tube diameter, wall thickness, length, sizes, and tolerances shall be a part of the purchase order as agreed upon between the supplier and the purchaser.

4.1.5 Quantity or total length of each size,

4.1.6 Finish (11.2 and 11.3),

4.1.6.1 When product is to be subjected to welding or brazing, the purchase order or contract shall specify product to be “specially cleaned,” and

4.1.7 Intended application.

4.2 The following options are available but may not be included unless specified at the time of order placement when required:

4.2.1 Heat identification or traceability details (5.1.2),

4.2.2 DELETED

4.2.3 DELETED

4.2.4 DELETED

4.2.5 If the product specification number must be marked on the shipping unit (21.2).

**5. Materials and Manufacture**

5.1 *Materials:*

5.1.1 The material of manufacture shall be a cast billet, bar, tube, or so forth of Copper Alloy UNS No. C61300, C61400, C63020, C65100, or C65500 and of such purity and soundness as to be suitable for processing into the products prescribed herein.

5.1.2 When specified in the contract or purchase order that heat identification or traceability is required, the purchaser shall specify the details desired.

NOTE 1—Due to the discontinuous nature of the processing of castings into wrought products, it is not always practical to identify a specific casting analysis with a specific quantity of finished material.

5.2 *Manufacture:*

5.2.1 The product shall be manufactured by hot working, cold working, and annealing processes as to produce a uniform wrought structure in the finished product.

5.2.2 The product shall be finished by such cold worked to the finished size, and subsequently annealed or heat treatment, when required, to meet the temper properties specified.

**TABLE 1 Chemical Requirements**

Copper Alloy UNS No.	C61300 <sup>A</sup>	C61400	C63020 <sup>B</sup>	C65100	C65500
	Composition, % Max (Unless Shown as a Range or Minimum)				
Copper <sup>C</sup>	remainder	remainder	74.5 min	remainder	remainder
Lead	0.01	0.01	0.03	0.05	0.05
Iron	2.0–3.0	1.5–3.5	4.0–5.5	0.8	0.8
Zinc	0.10	0.20	0.30	1.5	1.5
Aluminum	6.0–7.5	6.0–8.0	10.0–11.0	...	...
Manganese	0.20	1.0	1.5	0.7	0.50–1.3
Silicon	0.10	...	...	0.8–2.0	2.8–3.8
Tin	0.20–0.50	...	0.25	...	...
Nickel (including cobalt)	0.15	...	4.2–6.0	...	0.6
Phosphorus	0.015	0.015	...	...	...

<sup>A</sup> When the product is for subsequent welding applications and is so specified by the purchaser, chromium shall be 0.05 % max, cadmium 0.05 % max, zinc 0.05 % max, and zirconium 0.05 % max.

<sup>B</sup> Chromium shall be 0.05 max and cobalt 0.20 max.

<sup>C</sup> Including silver.

5.2.3 Copper alloy UNS No. C63020 tube shall be quench hardened and tempered (TQ30) as follows:

5.2.3.1 Heat to 1550 to 1650 °F (843 to 899 °C) for 2 h minimum and quench in water. Then, temper at 900 to 1000 °F (482 to 538 °C) for 2 h minimum and air cool to room temperature.

## 6. Chemical Composition

6.1 The material shall conform to the chemical composition requirements in Table 1 for the Copper [Alloy] UNS No. Designation specified in the ordering information.

6.1.1 Results of analysis on a product (check) sample shall conform to the composition requirements within the permitted analytical variance specified in Table 1.

6.2 These composition limits do not preclude the presence of other elements. By agreement between the manufacturer and purchaser, limits may be established and analysis required for unnamed elements.

6.2.1 For alloys in which copper is listed as “remainder,” copper is the difference between the sum of results of all elements determined and 100%.

6.2.1.1 When all the elements listed for an alloy in Table 1 are determined, the sum of the determined elements for the alloy shall be as shown in the following table:

Copper Alloy UNS No.	Copper Plus Named Elements, % min
C61300	99.8
C61400	99.5
C63020	99.5
C65100	99.5
C65500	99.5

## 7. Temper

7.1 The standard tempers for products described in this specification are listed as follows and in Table 2:

7.1.1 Alloys C61300 and C61400 are supplied in tempers M30 (hot-extruded) and O61 (annealed).

7.1.2 Alloy C63020 is supplied in temper TQ30 (quench hardened and tempered).

7.1.3 Alloy C65100 is supplied in tempers O30 (extruded and annealed), O61 (annealed), and H50 (extruded and cold worked).

7.1.4 Alloy C65500 is supplied in tempers O30 (extruded and annealed) and O61 (annealed).

## 8. Mechanical Property Requirements

### 8.1 Tensile Strength Requirements:

8.1.1 Product furnished under this specification shall conform to the tensile, yield, and elongation requirements prescribed in Table 2, when tested in accordance with Test Methods E8/E8M.

8.1.1.1 Acceptance or rejection based on mechanical properties shall depend only upon tensile, yield, or elongation test results.

### 8.2 Rockwell Hardness Requirement:

8.2.1 Product furnished from Alloy C63020 in TQ30 temper should have a minimum hardness of 26 on the Rockwell C scale when tested in accordance with Test Methods E18.

8.2.1.1 The approximate Rockwell hardness values given are for general information and assistance in testing and shall not be used as a basis for product rejection. The test is optional.

NOTE 2—The Rockwell hardness test offers a quick and convenient method of checking for general conformity to the specification requirements for temper, tensile strength, and grain size.

## 9. Nondestructive Test

### 9.1 Nondestructive Testing:

9.1.1 The tubes shall be tested in the drawn tempers or as drawn before the final annealed temper unless otherwise agreed upon between the manufacturer and the purchaser.

9.1.1.1 Each pipe or tube shall be subjected to either the hydrostatic test, pneumatic test, or the eddy current test. The type of test to be used shall be at the option of the manufacturer, unless otherwise specified in the purchase order. Section 12, Sampling, does not apply.

### 9.1.2 Electromagnetic (Eddy-Current Test):

9.1.2.1 Each tube up to and including 3/8 in. (79 mm) in outside diameter shall be subjected to test.

9.1.2.2 When tested in accordance with Practice E243, tubes which do not actuate the signaling device of the testing unit shall be considered as conforming to the requirements of the test.

9.1.2.3 *Artificial Defects*—Round bottom-notch standards with a profile as defined in Practice E243, rounded to the nearest 0.001 in. (0.025 mm) shall be 10 % of the specified wall thickness. Notch-depth tolerances shall be  $\pm 0.0005$  in. (0.013 mm). Alternatively, when a manufacturer uses speed-insensitive equipment that can select a maximum unbalance signal, a maximum unbalance signal of 0.3 % shall be used.

9.1.3 *Pressure Tests*—Each pipe or tube shall withstand the pressure test of either 9.1.3.1 or 9.1.3.2.

TABLE 2 Tensile Requirements

Copper Alloy UNS No. Temper Designation	C61300 and C61400	C63020	C65100		C65500
	M30 (Extruded) or O61 (Annealed)	TQ30 (Quench-Hardened and Tempered)	O30 (Extruded and Annealed) or O61 (Annealed)	H50 (Extruded and Cold-Worked)	O30 (Extruded and Annealed) and O61 (Annealed)
Tensile Strength, min, ksi <sup>A</sup> (MPa) <sup>B</sup>	65 (450)	130 (895)	40 (275)	50 (345)	50 (345)
Yield Strength at 0.5 % extension under load, ksi <sup>A</sup> (MPa) <sup>B</sup>	28 (195) min	89 (615) <sup>C</sup>	10 (70) min	40 (275) min	15 to 29 (105 to 200)
Elongation in 2 in. or 50 mm, min %	30	6	35	7	35

<sup>A</sup> ksi = 1000 psi.

<sup>B</sup> See Appendix.

<sup>C</sup> Yield strength at 0.2 % offset, min, ksi<sup>A</sup> (MPa).<sup>B</sup>

9.1.3.1 *Hydrostatic Pressure Test*—Each pipe or tube shall withstand an internal hydrostatic pressure sufficient to produce a fiber stress of 7000 psi (48 MPa) without leakage. The tube need not be subjected to a pressure gauge reading over 1000 psi (6.9 MPa) unless specifically stipulated in the contract or purchase order. At the option of the manufacturer, annealed pipe with wall thickness up to 0.083 in. (2.11 mm), inclusive, may be tested in the drawn condition, before annealing. Fiber stress shall be determined by the following equation for thin, hollow cylinders under tension:

$$P = 2St/(D - 0.8t) \tag{1}$$

where:

- $P$  = hydrostatic pressure, psi (MPa);
- $t$  = thickness of pipe or tube wall, in. (mm);
- $D$  = outside diameter of the pipe or tube, in. (mm); and
- $S$  = allowable fiber stress of the material, psi (MPa).

9.1.3.2 *Pneumatic Pressure Test*— Each pipe or tube shall withstand an internal air pressure of 60 psi (400 kPa), minimum for 5 s without leakage.

10. Dimensions, Mass, and Permissible Variations

10.1 General:

10.1.1 The standard method of specifying wall thickness shall be in decimal fractions of an inch.

10.1.2 For the purpose of determining conformance with the dimensional requirements prescribed in this specification, any measured value outside the specified limiting values for any dimension may be cause for rejection.

10.1.3 Tolerances on a given tube may be specified with respect to any two, but not all three, of the following: outside diameter, inside diameter, wall thickness.

NOTE 3—Spaces that contain an ellipsis (...) in the tolerance tables indicate either that the product is not generally available or that no tolerances have been established.

10.2 *Dimensions*—Dimensions and theoretical weights of nominal pipe sizes shall be in accordance with Table 3.

10.3 *Wall Thickness Tolerances*—Wall thickness tolerances for pipe shall be in accordance with Tables 4 and 5. Wall thickness tolerances for tube shall be in accordance with Tables 6-8.

TABLE 3 Dimensions and Weights of Copper Alloy Pipe, Standard Pipe Sizes

Nominal or Standard Pipe Size, in.	Dimension, in. (mm)			Cross-Sectional Area of Bore, in. <sup>2</sup> (cm <sup>2</sup> )	Theoretical Weight, lb/ft (kg/m)		
	Outside Diameter	Inside Diameter	Wall Thickness		Copper Alloy UNS No.		
					C61300 and C61400	C65500	C65100
Regular							
1/8	0.405 (10.3)	0.269 (6.83)	0.066 (1.73)	0.057 (0.367)	0.246 (0.366)	0.266 (0.395)	0.273 (0.406)
1/4	0.540 (13.7)	0.364 (9.25)	0.088 (2.24)	0.104 (0.670)	0.427 (0.634)	0.462 (0.686)	0.474 (0.704)
3/8	0.675 (17.1)	0.493 (12.5)	0.091 (2.31)	0.191 (1.23)	0.571 (0.849)	0.617 (0.917)	0.633 (0.941)
1/2	0.840 (21.3)	0.622 (15.8)	0.109 (2.77)	0.304 (1.96)	0.856 (1.27)	0.925 (1.37)	0.949 (1.41)
3/4	1.050 (26.7)	0.824 (20.9)	0.113 (2.87)	0.533 (3.44)	1.14 (1.69)	1.23 (1.83)	1.26 (1.88)
1	1.315 (33.4)	1.049 (26.6)	0.133 (3.38)	0.864 (3.57)	1.69 (2.51)	1.83 (2.72)	1.87 (2.79)
1 1/4	1.660 (42.2)	1.380 (35.1)	0.140 (3.56)	1.496 (9.66)	2.29 (3.40)	2.47 (3.68)	2.53 (3.77)
1 1/2	1.900 (48.3)	1.610 (40.9)	0.145 (3.68)	2.036 (13.1)	2.74 (4.07)	2.95 (4.40)	3.03 (4.51)
2	2.375 (60.3)	2.067 (52.5)	0.154 (3.91)	3.356 (21.7)	3.67 (5.45)	3.97 (5.91)	4.07 (6.06)
2 1/2	2.875 (73.0)	2.469 (62.7)	0.203 (5.16)	4.788 (30.9)	5.83 (8.66)	6.30 (9.37)	6.46 (9.61)
3	3.500 (88.9)	3.068 (77.9)	0.216 (5.49)	7.393 (47.7)	7.62 (11.3)	8.24 (12.3)	8.45 (12.6)
3 1/2	4.000 (102)†	3.548 (90.1)	0.226 (5.74)	9.887 (63.8)	9.16 (13.6)	9.90 (14.7)	10.2 (15.1)
4	4.500 (114)	4.026 (102)	0.237 (6.02)	12.730 (82.1)	10.9 (16.2)	11.7 (17.5)	12.0 (17.9)
5	5.562 (141)	5.046 (128)	0.258 (6.55)	19.998 (129)	14.7 (21.8)	15.9 (23.6)	16.3 (24.3)
6	6.625 (168)	6.065 (154)	0.280 (7.11)	28.890 (186)	19.1 (28.4)	20.6 (30.7)	21.2 (31.5)
8	8.625 (219)	7.981 (203)	0.322 (8.18)	50.030 (323)	28.7 (42.7)	31.0 (46.2)	31.9 (47.4)
10	10.750 (273)	10.020 (255)	0.365 (9.27)	78.8 (508)	40.8 (90.1)	44.1 (65.6)	45.2 (67.3)
12	12.750 (324)	12.000 (305)	0.375 (9.52)	113.0 (729)	49.9 (74.1)	53.9 (80.2)	55.3 (82.3)
Extra Strong							
1/8	0.405 (10.3)	0.215 (5.46)	0.095 (2.41)	0.036 (0.232)	0.316 (0.470)	0.342 (0.508)	0.351 (0.522)
1/4	0.540 (13.7)	0.302 (7.67)	0.119 (3.02)	0.072 (0.464)	0.538 (0.799)	0.582 (0.865)	0.597 (0.887)
3/8	0.675 (17.1)	0.423 (10.7)	0.126 (3.20)	0.141 (0.909)	0.743 (1.10)	0.803 (1.19)	0.824 (1.22)
1/2	0.840 (21.3)	0.546 (13.9)	0.147 (3.73)	0.234 (1.51)	1.10 (1.63)	1.183 (1.76)	1.214 (1.80)
3/4	1.050 (26.7)	0.742 (18.8)	0.154 (3.91)	0.432 (2.79)	1.48 (2.20)	1.60 (2.39)	1.65 (2.45)
1	1.315 (33.4)	0.957 (24.3)	0.179 (4.55)	0.719 (4.64)	2.19 (3.25)	2.36 (3.52)	2.42 (3.61)
1 1/4	1.660 (42.2)	1.278 (32.5)	0.191 (4.85)	1.283 (8.28)	3.01 (4.47)	3.26 (4.85)	3.34 (4.97)
1 1/2	1.900 (48.3)	1.500 (38.1)	0.200 (5.08)	1.767 (11.4)	3.65 (5.42)	3.95 (5.88)	4.05 (6.03)
2	2.375 (60.3)	1.939 (49.3)	0.218 (5.54)	2.953 (19.1)	5.05 (7.50)	5.46 (8.12)	5.60 (8.34)
2 1/2	2.875 (73.0)	2.323 (59.0)	0.276 (7.01)	4.238 (27.3)	7.71 (11.4)	8.33 (12.4)	8.55 (12.7)
3	3.500 (88.9)	2.900 (73.7)	0.300 (7.62)	6.605 (42.6)	10.3 (15.3)	11.1 (16.6)	11.4 (17.0)
3 1/2	4.000 (102)	3.364 (85.5)	0.318 (8.08)	8.888 (57.3)	12.6 (18.7)	13.6 (20.2)	13.9 (20.8)
4	4.500 (114)	3.826 (97.2)	0.337 (8.56)	11.497 (74.1)	15.1 (22.4)	16.3 (24.2)	16.7 (24.9)
5	5.562 (141)	4.812 (122)	0.375 (9.53)	18.186 (117)	20.9 (31.1)	22.6 (33.6)	23.2 (34.5)
6	6.625 (168)	5.761 (146)	0.432 (10.9)	26.067 (168)	28.7 (42.6)	31.1 (46.2)	31.9 (47.4)
8	8.625 (219)	7.625 (194)	0.500 (12.7)	45.664 (295)	43.6 (64.8)	47.2 (70.2)	48.4 (72.0)
10	10.750 (273)	9.750 (248)	0.500 (12.7)	74.7 (482)	55.1 (81.9)	59.5 (88.5)	61.1 (90.9)

**TABLE 4 Dimensional Limits for Standard Pipe Sizes**  
Copper Alloy UNS No. C61300 and C61400

Nominal or Standard Pipe Size	Outside Diameter, in. (mm)	Min	Max	Regular			Extra Strong		
				Wall Thickness, in. (mm)	Min	Max	Wall Thickness, in. (mm)	Min	Max
1/8	0.405 (10.3)	0.374 (9.50)	0.421 (10.7)	0.068 (1.73)	0.061 (1.55)	0.075 (1.91)	0.095 (2.41)	0.086 (2.18)	0.105 (2.67)
1/4	0.540 (13.7)	0.509 (12.9)	0.556 (14.1)	0.088 (2.24)	0.079 (2.01)	0.097 (2.46)	0.119 (3.02)	0.107 (2.72)	0.131 (3.33)
3/8	0.675 (17.1)	0.644 (16.4)	0.691 (17.6)	0.091 (2.31)	0.082 (2.08)	0.100 (2.54)	0.126 (3.20)	0.113 (2.87)	0.139 (3.53)
1/2	0.840 (21.3)	0.809 (20.5)	0.856 (21.7)	0.109 (2.77)	0.098 (2.49)	0.120 (3.05)	0.147 (3.73)	0.132 (3.35)	0.162 (4.11)
3/4	1.050 (26.7)	1.019 (25.9)	1.066 (27.1)	0.113 (2.87)	0.102 (2.59)	0.124 (3.15)	0.154 (3.91)	0.139 (3.53)	0.169 (4.29)
1	1.315 (33.4)	1.284 (32.6)	1.331 (33.8)	0.133 (3.38)	0.120 (3.05)	0.146 (3.71)	0.179 (4.55)	0.161 (4.09)	0.197 (5.00)
1 1/4	1.660 (42.2)	1.629 (41.4)	1.676 (42.6)	0.140 (3.56)	0.126 (3.20)	0.154 (3.91)	0.191 (4.85)	0.172 (4.37)	0.210 (5.33)
1 1/2	1.900 (48.3)	1.869 (47.5)	1.916 (48.7)	0.145 (3.68)	0.131 (3.33)	0.160 (4.06)	0.200 (5.08)	0.180 (4.57)	0.220 (5.59)
2	2.375 (60.3)	2.351 (59.7)	2.399 (60.9)	0.154 (3.91)	0.139 (3.53)	0.169 (4.29)	0.218 (5.54)	0.196 (4.98)	0.240 (6.10)
2 1/2	2.875 (73.0)	2.846 (72.3)	2.904 (73.8)	0.203 (5.16)	0.183 (4.65)	0.223 (5.66)	0.276 (7.01)	0.248 (6.30)	0.304 (7.72)
3	3.500 (88.9)	3.465 (88.0)	3.535 (89.8)	0.216 (5.49)	0.194 (4.93)	0.238 (6.05)	0.300 (7.62)	0.270 (6.86)	0.330 (8.38)
3 1/2	4.000 (102)	3.960 (101)	4.040 (103)	0.226 (5.74)	0.203 (5.16)	0.249 (6.32)	0.318 (8.08)	0.286 (7.26)	0.350 (8.89)
4	4.500 (114)	4.455 (113)	4.545 (115)	0.237 (6.02)	0.213 (5.41)	0.261 (6.63)	0.337 (8.56)	0.303 (7.70)	0.371 (9.42)
5	5.562 (141)	5.506 (140)	5.618 (143)	0.258 (6.55)	0.232 (5.89)	0.284 (7.21)	0.375 (9.53)	0.338 (8.59)	0.413 (10.5)
6	6.625 (168)	6.559 (167)	6.691 (170)	0.280 (7.11)	0.252 (6.40)	0.308 (7.82)	0.432 (11.0)	0.389 (9.88)	0.475 (12.1)
8	8.625 (219)	8.539 (217)	8.711 (221)	0.322 (8.18)	0.290 (7.37)	0.354 (8.99)	0.500 (12.7)	0.450 (11.4)	0.550 (14.0)
10	10.750 (273)	10.643 (270)	10.858 (276)	0.365 (9.27)	0.329 (8.36)	0.402 (10.2)	0.500 (12.7)	0.450 (11.4)	0.550 (14.0)
12	12.750 (324)	12.623 (321)	12.878 (327)	0.375 (9.53)	0.338 (8.59)	0.413 (10.5)	...	...	...

**TABLE 5 Dimensional Limits for Standard Pipe Sizes**  
Copper Alloy UNS No. C65100 and C65500

Nominal or Standard Pipe Size	Outside Diameter, in. (mm)	Min	Max	Regular			Extra Strong		
				Wall Thickness, in. (mm)	Min	Max	Wall Thickness, in. (mm)	Min	Max
1/8	0.405 (10.3)	0.374 (9.50)	0.421 (10.7)	0.068 (1.73)	0.065 (1.65)	0.083 (2.11)	0.095 (2.41)	0.090 (2.29)	0.123 (3.12)
1/4	0.540 (13.7)	0.509 (12.9)	0.556 (14.1)	0.088 (2.24)	0.084 (2.13)	0.102 (2.59)	0.119 (3.02)	0.107 (2.72)	0.144 (3.66)
3/8	0.675 (17.1)	0.644 (16.4)	0.691 (17.6)	0.091 (2.31)	0.086 (2.18)	0.103 (2.62)	0.126 (3.20)	0.120 (3.05)	0.146 (3.71)
1/2	0.840 (21.3)	0.809 (20.5)	0.856 (21.7)	0.109 (2.77)	0.104 (2.64)	0.122 (3.10)	0.147 (3.73)	0.140 (3.56)	0.166 (4.22)
3/4	1.050 (26.7)	1.019 (25.9)	1.066 (27.1)	0.113 (2.87)	0.107 (2.72)	0.124 (3.15)	0.154 (3.91)	0.146 (3.71)	0.171 (4.34)
1	1.315 (33.4)	1.284 (32.6)	1.331 (33.8)	0.133 (3.38)	0.126 (3.20)	0.145 (3.68)	0.179 (4.55)	0.170 (4.32)	0.196 (4.98)
1 1/4	1.660 (42.2)	1.629 (41.4)	1.676 (42.6)	0.140 (3.56)	0.133 (3.38)	0.151 (3.84)	0.191 (4.85)	0.181 (4.60)	0.207 (5.26)
1 1/2	1.900 (48.3)	1.869 (47.5)	1.916 (48.7)	0.145 (3.68)	0.138 (3.51)	0.156 (3.96)	0.200 (5.08)	0.190 (4.83)	0.216 (5.49)
2	2.375 (60.3)	2.351 (59.7)	2.399 (60.9)	0.154 (3.91)	0.146 (3.71)	0.164 (4.17)	0.218 (5.54)	0.207 (5.26)	0.233 (5.92)
2 1/2	2.875 (73.0)	2.846 (72.3)	2.904 (73.8)	0.203 (5.16)	0.193 (4.90)	0.217 (5.51)	0.276 (7.01)	0.262 (6.65)	0.295 (7.49)
3	3.500 (88.9)	3.465 (88.0)	3.535 (89.8)	0.216 (5.49)	0.205 (5.21)	0.230 (5.84)	0.300 (7.62)	0.285 (7.24)	0.321 (8.15)
3 1/2	4.000 (102)	3.960 (101)	4.040 (103)	0.226 (5.74)	0.215 (5.46)	0.240 (6.10)	0.318 (8.08)	0.302 (7.67)	0.340 (8.64)
4	4.500 (114)	4.455 (113)	4.545 (115)	0.237 (6.02)	0.225 (5.72)	0.252 (6.40)	0.337 (8.56)	0.320 (8.13)	0.360 (9.14)
5	5.562 (141)	5.506 (140)	5.618 (143)	0.258 (6.55)	0.245 (6.22)	0.275 (6.99)	0.375 (9.53)	0.356 (9.04)	0.400 (10.2)
6	6.625 (168)	6.559 (167)	6.691 (170)	0.280 (7.11)	0.266 (6.76)	0.298 (7.57)	0.432 (11.0)	0.410 (10.4)	0.461 (11.7)
8	8.625 (219)	8.539 (217)	8.711 (221)	0.322 (8.18)	0.299 (7.59)	0.349 (8.86)	0.500 (12.7)	0.465 (11.8)	0.554 (13.8)
10	10.750 (273)	10.643 (270)	10.858 (276)	0.365 (9.27)	0.336 (8.53)	0.400 (10.2)	0.500 (12.7)	0.460 (11.7)	0.548 (13.9)
12	12.750 (324)	12.623 (321)	12.878 (327)	0.375 (9.53)	0.345 (8.76)	0.410 (10.4)	...	...	...

**TABLE 6 Wall Thickness Tolerances for Copper Alloy UNS No. C61300 and C61400 Tube (Not Applicable to Pipe)**

NOTE 1—Maximum deviation at any point—the following tolerances are plus and minus; if tolerances all plus or all minus are desired, double the values given.

Wall Thickness, in. (mm)	Outside Diameter, in. (mm)		
	Over 3/8 to 1 (15.9 to 25.4) incl.	Over 1 to 2 (25.4 to 50.8) incl.	Over 2 to 4 (50.8 to 102) incl.
Over 0.024 (0.610) to 0.034 (0.864), incl.	0.003(0.076)	0.004(0.10)	0.004(0.10)
Over 0.034 (0.864) to 0.057 (1.45), incl.	0.0045(0.11)	0.005(0.13)	0.006(0.15)
Over 0.057 (1.45) to 0.082 (2.08), incl.	0.005(0.13)	0.006(0.15)	0.008(0.20)
Over 0.082 (2.08) to 0.119 (3.02), incl.	0.007(0.18)	0.008(0.20)	0.009(0.23)
Over 0.119 (3.02) to 0.164 (4.17), incl.	0.009(0.23)	0.010(0.25)	0.012(0.30)

10.4 Diameter Tolerances—Diameter tolerances for pipe and tube shall be as follows:

10.4.1 Diameter Tolerances for Pipe:

Nominal Pipe Size, in. (mm)	Diameter Tolerance, in. (mm)
1 1/2 (38.1) and under	+0.016 -0.031 (+0.40 -0.79)
Over 1 1/2	

10.4.2 The dimensional limits of nominal pipe sizes are shown in Tables 4 and 5.

10.4.3 Diameter tolerances for tube shall be in accordance with Table 9.

**TABLE 7 Wall Thickness Tolerances for Copper Alloy UNS No. C65500 Tube (Not Applicable to Pipe)**

NOTE 1—Maximum deviation at any point—the following tolerances are plus and minus; if tolerances all plus or all minus are desired, double the values given.

Wall Thickness, in. (mm)	Outside Diameter, <sup>A</sup> in. (mm)						
	1/32 to 1/8 (0.792 to 3.18), incl.	Over 1/8 to 3/8 (3.18 to 15.9), incl.	Over 3/8 to 1 (15.9 to 25.4), incl.	Over 1 to 2 (25.4 to 50.8), incl.	Over 2 to 4 (50.8 to 102), incl.	Over 4 to 7 (102 to 173), incl.	Over 7 to 10 (173 to 251), incl.
Up to 0.017 (0.432), incl.	0.0025 (0.064)	0.0015 (0.038)	0.002 (0.051)	0.0025 (0.064)	...	...	...
Over 0.017 (0.432) to 0.024 (0.610), incl.	0.004 (0.10)	0.0025 (0.064)	0.0025 (0.064)	0.003 (0.076)	...	...	...
Over 0.024 (0.610) to 0.034 (0.864), incl.	0.004 (0.10)	0.003 (0.076)	0.003 (0.076)	0.004 (0.10)	0.005 (0.13)	...	...
Over 0.034 (0.864) to 0.057 (1.45), incl.	0.004 (0.10)	0.001 (0.10)	0.0045 (0.11)	0.0045 (0.11)	0.0065 (0.17)	0.009 (0.23)	...
Over 0.057 (1.45) to 0.082 (2.08), incl.	...	0.0045 (0.11)	0.005 (0.13)	0.005 (0.13)	0.0075 (0.19)	0.010 (0.25)	0.013 (0.33)
Over 0.082 (2.08) to 0.119 (3.02), incl.	...	0.005 (0.13)	0.0065 (0.17)	0.0065 (0.17)	0.009 (0.23)	0.011 (0.28)	0.014 (0.36)
Over 0.119 (3.02) to 0.164 (4.17), incl.	...	0.007 (0.18)	0.007 (0.18)	0.0075 (0.19)	0.010 (0.25)	0.013 (0.33)	0.015 (0.38)
Over 0.164 (4.17) to 0.219 (5.56), incl.	...	...	0.009 (0.23)	0.010 (0.25)	0.012 (0.30)	0.015 (0.38)	0.018 (0.46)
Over 0.219 (5.56) to 0.283 (7.19), incl.	...	...	0.012 (0.30)	0.013 (0.33)	0.015 (0.38)	0.018 (0.46)	0.020 (0.51)
Over 0.283 (7.19) to 0.379 (9.62), incl.	...	...	0.014 (0.36)	6 <sup>B</sup>	6 <sup>B</sup>	8 <sup>B</sup>	8 <sup>B</sup>
Over 0.379 (9.62)	...	...	...	6 <sup>B</sup>	6 <sup>B</sup>	8 <sup>B</sup>	8 <sup>B</sup>

<sup>A</sup> When tube is ordered by outside and inside diameters, the maximum plus and minus deviation of the wall thickness from the nominal at any point shall not exceed the values given in this table by more than 50 %.

<sup>B</sup> Percent of the specified wall thickness expressed to the nearest 0.001 in. (0.025 mm).

**TABLE 8 Wall Thickness Tolerances for Copper Alloy UNS No. C65100 Tube (Not Applicable to Pipe)**

NOTE 1—Maximum deviation at any point—the following tolerances are plus and minus; if tolerances all plus or all minus are desired, double the values given.

Wall Thickness, in. (mm)	Outside Diameter, <sup>A</sup> in. (mm)						
	1/32 (0.792) to 1/8 (3.18), incl.	Over 1/8 (3.18) to 3/8 (15.9), incl.	Over 3/8 (15.9) to 1 (25.4), incl.	Over 1 (25.4) to 2 (50.8), incl.	Over 2 (50.8) to 4 (102), incl.	Over 4 (102) to 7 (213), incl.	Over 7 (213) to 10 (254), incl.
Up to 0.017 (0.432), incl.	0.002 (0.051)	0.001 (0.025)	0.0015 (0.038)	0.002 (0.051)	...	...	...
Over 0.017 (0.432) to 0.024 (0.610), incl.	0.003 (0.076)	0.002 (0.051)	0.002 (0.051)	0.0025 (0.064)	...	...	...
Over 0.024 (0.610) to 0.034 (0.864), incl.	0.003 (0.076)	0.0025 (0.064)	0.0025 (0.064)	0.003 (0.076)	0.004 (0.10)	...	...
Over 0.034 (0.864) to 0.057 (1.45), incl.	0.003 (0.076)	0.003 (0.076)	0.0035 (0.089)	0.0035 (0.089)	0.005 (0.13)	0.007 (0.18)	...
Over 0.057 (1.45) to 0.082 (2.08), incl.	...	0.0035 (0.089)	0.004 (0.10)	0.004 (0.10)	0.006 (0.15)	0.008 (0.20)	0.010 (0.26)
Over 0.082 (2.08) to 0.119 (3.02), incl.	...	0.004 (0.10)	0.005 (0.13)	0.005 (0.13)	0.007 (0.18)	0.009 (0.23)	0.011 (0.28)
Over 0.119 (3.02) to 0.164 (4.17), incl.	...	0.005 (0.13)	0.006 (0.15)	0.006 (0.15)	0.008 (0.20)	0.010 (0.25)	0.012 (0.30)
Over 0.164 (4.17) to 0.219 (5.56), incl.	...	0.007 (0.18)	0.0075 (0.19)	0.008 (0.20)	0.010 (0.25)	0.012 (0.30)	0.014 (0.36)
Over 0.219 (5.56) to 0.283 (7.19), incl.	...	...	0.009 (0.23)	0.010 (0.25)	0.012 (0.30)	0.014 (0.36)	0.016 (0.44)
Over 0.283 (7.19) to 0.379 (9.62), incl.	...	...	0.012 (0.30)	5 <sup>B</sup>	5 <sup>B</sup>	6 <sup>B</sup>	6 <sup>B</sup>
Over 0.379 (9.62), incl.	...	...	...	5 <sup>B</sup>	5 <sup>B</sup>	6 <sup>B</sup>	6 <sup>B</sup>

<sup>A</sup> When tube is ordered by outside and inside diameters, the maximum plus and minus deviation of the wall thickness from the nominal at any point shall not exceed the values given in this table by more than 50 %.

<sup>B</sup> Percent of the specified wall thickness expressed to the nearest 0.001 in. (0.025 mm).

10.5 Length Tolerances:

10.5.1 Length tolerances shall be in accordance with Table 10.

10.5.2 Schedule of Tube Lengths—Specific and stock lengths with ends shall be in accordance with Table 11.

10.6 Squareness of Cut—For pipe and tube in straight lengths, the departure from squareness of the end of any pipe or tube shall not exceed the following:

10.6.1 Pipe:

Outside Diameter	Tolerance
Up to 3/8 in. (15.9 mm), incl.	0.010 in. (0.25 mm)
Over 3/8 in. (15.9 mm)	0.016 in./in. (0.016 mm/mm) of diameter

10.6.2 Tube:

Outside Diameter	Tolerance
Up to 3/8 in. (15.9 mm), incl.	0.010 in. (0.25 mm)
Over 3/8 in. (15.9 mm)	0.016 in./in. (0.016 mm/mm) of diameter

**TABLE 9 Average Diameter Tolerances for Tube (Not Applicable to Pipe)**

Copper Alloy UNS No.	Tolerance, ±in. (mm) <sup>A</sup>		
	Specified Diameter, in. (mm)	C61300 and C61400	C65100 C65500
Up to 1/8 (3.18), incl.	...	0.002 (0.051) <sup>B</sup>	0.003 (0.076) <sup>B</sup>
Up to 1/8 (3.18), incl.	...	0.002 (0.051) <sup>C</sup>	0.025 (0.064) <sup>C</sup>
Over 1/8 (3.18) to 3/8 (15.9), incl.	0.004 (0.10)	0.002 (0.051)	0.0025 (0.064)
Over 3/8 (15.9) to 1 (25.4), incl.	0.005 (0.13)	0.0025 (0.064)	0.003 (0.076)
Over 1 (25.4) to 2 (50.8), incl.	0.006 (0.15)	0.003 (0.076)	0.004 (0.10)
Over 2 (50.8) to 3 (76.2), incl.	0.007 (0.18)	0.004 (0.10)	0.005 (0.13)
Over 3 (76.2) to 4 (102), incl.	...	0.005 (0.13)	0.006 (0.15)
Over 4 (102) to 5 (127), incl.	...	0.006 (0.15)	0.008 (0.20)
Over 5 (127) to 6 (152), incl.	...	0.007 (0.18)	0.009 (0.23)
Over 6 (152) to 8 (203), incl.	...	0.008 (0.20)	0.010 (0.25)
Over 8 (203) to 10 (254), incl.	...	0.010 (0.25)	0.013 (0.33)

<sup>A</sup> Tolerance applies to inside or outside diameters, except as noted.

<sup>B</sup> On inside diameter.

<sup>C</sup> On outside diameter.

**TABLE 10 Length Tolerances**

NOTE 1—Tolerances are all plus—If all minus tolerances are desired, use the same value. If tolerances plus and minus are desired, halve the values given.

Length	Tolerances, in. (mm), Applicable only to Full Length Pieces		
	Outside Diameters up to 1 in. (25.4 mm), incl.	Outside Diameters over 1 in. (25.4 mm) to 4 in. (102 mm), incl.	Outside Diameters over 4 in. (102 mm)
Specific lengths:			
Up to 6 in. (152 mm), incl.	1/32 (0.79)	1/16 (1.6)	...
Over 6 in. (152 mm) to 2 ft (610 mm), incl.	1/16 (1.6)	3/32 (2.4)	1/8 (3.2)
Over 2 ft (610 mm) to 6 ft (1.83 m), incl.	3/32 (2.4)	1/8 (3.2)	1/4 (6.4)
Over 6 ft (1.83 m) to 14 ft (4.27 m), incl.	1/4 (6.4)	1/4 (6.4)	1/4 (6.4)
Over 14 ft (4.27 m)	1/2 (13)	1/2 (13)	1/2 (13)
Specific lengths with ends	1 (25)	1 (25)	1 (25)
Stock lengths with or without ends	1 <sup>A</sup> (25)	1 <sup>A</sup> (25)	1 <sup>A</sup> (25)

<sup>A</sup> As stock lengths are cut and placed in stock in advance of orders, departure from this tolerance is not practicable.

**TABLE 11 Schedule of Tube Lengths (Specific and Stock) with Ends**

Outside Dimensions, in. (mm)	Specific Length, ft (m)	Shortest Permissible Length, <sup>A</sup> % of Specific Length	Maximum Permissible Weight of Ends, % of Lot Weight
Up to 1 (25.4), incl.	6 (1.83) to 20 (6.10), incl.	70	20
Over 1 (25.4) to 2 (50.8), incl.	6 (1.83) to 20 (6.10), incl.	60	25
Over 2 (50.8) to 3 (76.2), incl.	6 (1.83) to 20 (6.10), incl.	55	30
Over 3 (76.2) to 4 (102), incl.	6 (1.83) to 20 (6.10), incl.	50	40

<sup>A</sup> Expressed to nearest 1/8 ft.

10.7 The nominal density of materials used in the manufacture of products for this specification are shown in Table X2.1.

**11. Workmanship, Finish, and Appearance**

11.1 The product shall be free from defects, but blemishes of a nature that do not interfere with the intended application are acceptable.

11.2 Copper alloy UNS Nos. 65100 and 65500 may be supplied in the following finishes:

11.2.1 *Specially Cleaned*—Intended for brazing and welded operations.

11.2.2 Plain-pickled, or with dull iridescent film, on both the inside and outside surfaces.

NOTE 4—Plain-pickled material normally has a brick red color with cuprous and silicon oxides still adherent.

11.3 Copper alloy UNS Nos. C61300 and C61400 shall be supplied with the normal as-extruded or annealed tarnish unless otherwise specified on the purchase order.

**12. Sampling**

12.1 *Sampling*—The lot size, portion size, and selection of sample pieces shall be as follows:

12.1.1 *Lot Size*—For tube, the lot size shall be 10 000 lb (4550 kg) or fraction thereof. For pipe, the lot size shall be as follows:

Nominal Pipe Size, in (mm)	Lot Weight, lb (kg)
Up to 4 (101.6), incl.	10 000 (4550) or fraction thereof
Over 4 (101.6)	40 000 (18 100) or fraction thereof

12.1.2 *Portion Size*—Sample pieces shall be taken for test purposes from each lot according to the following schedule. (Each sample shall be from a separate tube or pipe.)

Number of Pieces in Lot	Number of Sample Pieces to Be Taken
1 to 50	1
51 to 200	2
201 to 1500	3
Over 1500	0.2 % of total number of pieces in the lot

12.1.3 *Chemical Analysis*—A sample for chemical analysis shall be taken in accordance with Practice E255 for product in its final form. Unless otherwise required by the purchaser at the time the order is placed, the manufacturer shall have the option of determining conformance to chemical composition by analyzing samples taken at the time the castings are poured or samples taken from the semifinished product if heat identity can be maintained throughout all operations. If the manufacturer determines the chemical composition during manufacture, he shall not be required to sample and analyze the finished product. The minimum weight of the composite sample in accordance with Practice E255 shall be 150 g.

12.1.4 DELETED

12.1.5 *Samples for All Other Tests*—Samples for all other tests shall be taken from the sample portion in 12.1.3 and be of a convenient size to accommodate the test and comply with the requirements of the appropriate ASTM standards and test methods.

**13. Number of Test and Retests**

13.1 *Tests:*

13.1.1 *Chemical Analysis*—Chemical composition shall be determined in accordance with the element mean of the results from at least two replicate analyses of the samples.

13.1.2 *Mechanical Tests*—For the mechanical tests, a specimen shall be taken from each of the pieces selected in accordance with 12.1. The required mechanical test shall be made on each of the specimens selected.

13.1.2.1 If the percentage elongation of any tension test specimen is less than that specified and if any part of the fracture is outside the middle two thirds of the gage length or in a punched or scribed mark within the reduced section, a retest shall be allowed.

## 13.1.3 DELETED

## 13.2 Retests:

13.2.1 When requested by the manufacturer or supplier, a retest shall be permitted when results of tests obtained by the purchaser fail to conform to the requirements of the product specification.

13.2.2 The retest shall be as directed in the product specification for the initial test, except the number of test specimens shall be twice that normally required for the specified test.

13.2.3 All test specimens shall conform to the product specification requirement(s) in retest. Failure to conform shall be cause for rejection.

## 14. Specimen Preparation

14.1 *Chemical Analysis*—Preparation of the analytical test specimen is the responsibility of the reporting laboratory.

14.2 *Tensile Test*:

14.2.1 The test specimen shall be of the full section of the tube and shall conform to the requirements of the section titled Specimens for Pipe and Tube in Test Methods E8/E8M.

14.2.2 When the limitations of the testing equipment preclude the use of such a specimen, test specimens conforming to Type 1, Fig. 13, Tension Test Specimens for Large-Diameter Tubular Products, of Test Methods E8/E8M may be used when a full-section specimen cannot be tested.

14.3 *Rockwell Hardness*:

14.3.1 The test specimen shall be of the size and shape to permit testing with the available test equipment.

14.3.2 The surface of the specimen shall be sufficiently flat and smooth to permit the accurate determination of hardness.

14.3.3 The test specimen shall be sufficiently free of scale and foreign material to permit the accurate determination of hardness.

14.3.4 Care shall be taken to avoid changing the material's condition through either cold working or heating, or both.

## 15. Test Methods

15.1 *Chemical Analysis*:

15.1.1 In cases of disagreement, test methods for chemical analysis shall be subject to agreement between the manufacturer or supplier and the purchaser. The following table lists published chemical test methods, some of which may no longer be viable and which, along with others not listed, may be used, subject to agreement.

Test	Test Method
Copper	E478
Lead	E478 (AA)
Iron	E54
Zinc	E478 (AA)
Aluminum	E478 (Titrimetric)
Manganese	E62
Silicon	E62
Tin	E478 (Photometric)
Nickel (including cobalt)	E478
Phosphorus	E62

15.1.2 Test method(s) to be followed for the determination of element(s) resulting from contractual or purchase order agreement shall be as agreed upon between the manufacturer or supplier and purchaser.

15.2 *Other Tests*:

15.2.1 The product, when specified, shall conform to specified requirements when subjected to the test in accordance with the following table:

Test	Test Method
Electromagnetic (eddy current)	E243
Rockwell hardness	E18 and 14.3
Yield test	E8/E8M
Tension test	E8/E8M
Elongation	E8/E8M

15.2.2 *Tension Tests*:

15.2.2.1 When tension test results are obtained from both full-size and from machined test specimens and they differ, the results obtained from full-size test specimens shall prevail.

15.2.2.2 Tension test results on material covered by this specification are not seriously affected by variations in the speed of testing. A considerable range of testing speeds is permissible; however, the rate of stressing to obtain the yield strength should not exceed 100 ksi (690 MPa)/min. Above the yield strength, the movement per minute of the testing machine head under load should not exceed 0.5 in./in. (12 mm/mm) of gauge length (or distance between grips for full-section specimens).

## 16. Significance of Numerical Limits

16.1 For the purpose of determining compliance with the specified limits of the properties listed in the following table and for dimensional tolerances, an observed or a calculated value shall be rounded as indicated in accordance with the rounding method of Practice E29.

Property	Rounded Unit for Observed or Calculated Value
Chemical composition	Nearest unit in the last right-hand significant digit used in expressing the limiting value
Tensile Strength Yield Strength	nearest ksi (nearest 5 MPa)
Elongation	nearest 1 %

## 17. Inspection

17.1 The manufacturer or supplier shall inspect and make tests necessary to verify that the furnished product conforms to the specification requirements.

17.2 Source inspection of the product by the purchaser may be agreed upon between the manufacturer or supplier and the purchaser as a part of the purchase order. In such case, the nature of the facilities needed to satisfy the inspector, representing the purchaser, that the product is being furnished in accordance with the specification shall be included in the agreement. All testing and inspection shall be conducted so as not to interfere unnecessarily with the operation of the works.

17.3 When mutually agreed upon, the manufacturer or supplier and the purchaser shall conduct the final inspection simultaneously.

## 18. Rejection and Rehearing

### 18.1 Rejection:

18.1.1 Product that fails to conform to the specification requirements, when tested by the purchaser or purchaser's agent, shall be subject to rejection.

18.1.2 Rejection shall be reported to the manufacturer or supplier promptly. In addition, a written notification of rejection shall follow.

18.1.3 In case of dissatisfaction with the results of the test upon which rejection is based, the manufacturer or supplier shall have the option to make claim for a rehearing.

18.2 *Rehearing*—As a result of product rejection, the manufacturer or supplier shall have the option to make claim for a retest to be conducted by the manufacturer or supplier and the purchaser. Samples of the rejected product shall be taken in accordance with the product specification and subjected to test by both parties using the test method(s) specified in the product specification, or alternately, upon agreement of both parties, an independent laboratory may be selected for the test(s) using the test method(s) specified in the product specification.

## 19. Certification

19.1 The purchaser shall be furnished certification that samples representing each lot have been tested or inspected as directed in this specification and the requirements have been met.

19.2 DELETED

## 20. Test Report

20.1 A report of test results required by this specification shall be furnished.

## 21. Packaging and Package Marking

### 21.1 Packaging:

21.1.1 The product shall be separated by size, composition, and temper, and prepared for shipment by common carrier, in such a manner to afford protection from the normal hazards of transportation.

### 21.2 Package Marking:

21.2.1 Each shipping unit shall be legibly marked with the metal or alloy designation, temper, size, shape, gross and net weight, and name of supplier. Upon agreement between the purchaser and supplier, the purchase order number shall be indicated on each shipping unit or on the shipping documents.

21.2.2 When specified in the contract or purchase order, the product specification number shall be shown.

## 22. Keywords

22.1 seamless copper alloy pipe; seamless copper alloy tube; UNS Alloy No. C61300; UNS Alloy No. C61400; UNS Alloy No. C63020; UNS Alloy No. C65100; UNS Alloy No. C65500

## APPENDICES

### (Nonmandatory Information)

#### X1. METRIC EQUIVALENTS

X1.1 The SI unit for strength properties is shown in accordance with the International System of Units (SI). The derived SI unit for force is the Newton (N), which is defined as the force that when applied to a body having a mass of one kilogram gives it an acceleration of one metre per second squared ( $N = \text{kg} \cdot \text{m/s}^2$ ). The derived SI unit for pressure or

stress is the Newton per square metre ( $\text{N/m}^2$ ), which has been named the Pascal (Pa) by the General Conference on Weights and Measures. Since  $1 \text{ ksi} = 6\,894\,757 \text{ Pa}$ , the metric equivalents are expressed as megapascal (MPa), which is the same as  $\text{MN/m}^2$  and  $\text{N/mm}^2$ .

**X2. DENSITY OF COPPER ALLOYS**

X2.1 The densities of the alloys covered by this specification are given in Table X2.1.

**TABLE X2.1 Densities**

Copper Alloy UNS Number	Density, lb/in. <sup>3</sup> (g/cm <sup>3</sup> )
C61300	0.285 (7.89)
C61400	0.285 (7.89)
C63020	0.269 (7.45)
C65100	0.316 (8.78)
C65500	0.308 (8.53)

ASMENORMDOC.COM : Click to view the full PDF of ASME BPVC.II.B (ASME BPVC Section II part B) 2025

ASMENORMDOC.COM : Click to view the full PDF of ASME BPVC.II.B (ASME BPVC Section II part B) 2025

INTENTIONALLY LEFT BLANK

# SPECIFICATION FOR NICKEL-MOLYBDENUM ALLOY PLATE, SHEET, AND STRIP



**SB-333**



(Identical with ASTM Specification B333-03(2018).)

ASME BPVC Section II part B) 2025  
ASME BPVC.II.B (ASME BPVC Section II part B) 2025  
ASMENORMDOC.COM : Click to view the full PDF of ASME BPVC.II.B (ASME BPVC Section II part B) 2025

# Specification for Nickel-Molybdenum Alloy Plate, Sheet, and Strip

## 1. Scope

1.1 This specification covers plate, sheet, and strip of nickel-molybdenum alloys (UNS N10001, N10665, N10675, N10629, and N10624) as shown in Table 1, for use in general corrosive service.

1.2 The following products are covered under this specification:

1.2.1 *Sheet and Strip*—Hot or cold rolled, solution annealed, and descaled unless solution anneal is performed in an atmosphere yielding a bright finish.

1.2.2 *Plate*—Hot or cold rolled, solution annealed, and descaled.

1.3 The values stated in inch-pound units are to be regarded as standard. The values given in parentheses are mathematical conversions to SI units that are provided for information only and are not considered standard.

1.4 *This standard does not purport to address all of the safety concerns, if any, associated with its use. It is the responsibility of the user of this standard to become familiar with all hazards including those identified in the appropriate Safety Data Sheet (SDS) for this product/material as provided by the manufacturer, to establish appropriate safety, health, and environmental practices, and determine the applicability of regulatory limitations prior to use.*

1.5 *This international standard was developed in accordance with internationally recognized principles on standardization established in the Decision on Principles for the Development of International Standards, Guides and Recommendations issued by the World Trade Organization Technical Barriers to Trade (TBT) Committee.*

## 2. Referenced Documents

### 2.1 ASTM Standards:

B906 Specification for General Requirements for Flat-Rolled Nickel and Nickel Alloys Plate, Sheet, and Strip  
E112 Test Methods for Determining Average Grain Size  
E140 Hardness Conversion Tables for Metals Relationship Among Brinell Hardness, Vickers Hardness, Rockwell Hardness, Superficial Hardness, Knoop Hardness, Scleroscope Hardness, and Leeb Hardness

## 3. Terminology

### 3.1 Definitions of Terms Specific to This Standard:

3.1.1 *cold-rolled plate, n*—material  $\frac{3}{16}$  to  $\frac{3}{8}$  in. (4.76 to 9.52 mm), inclusive, in thickness.

3.1.2 *hot-rolled plate, n*—material  $\frac{3}{16}$  in. (4.76 mm) and over in thickness.

3.1.3 *plate, n*—material  $\frac{3}{16}$  in. (4.76 mm) and over in thickness.

3.1.4 *sheet and strip, n*—material under  $\frac{3}{16}$  in. (4.76 mm) in thickness.

## 4. General Requirements

4.1 Material furnished under this specification shall conform to the applicable requirements of Specification B906 unless otherwise provided herein.

## 5. Ordering Information

5.1 It is the responsibility of the purchaser to specify all requirements that are necessary for material ordered under this specification. Examples of such requirements include, but are not limited to the following:

5.1.1 *Alloy*—Table 1,

5.1.2 *Dimensions*—Thickness (in decimals of an inch), width, and length (inch or fractions of an inch),

5.1.3 *Optional Requirement*—Plate; how the plate is to be cut (Specification B906, Table A2.3)

TABLE 1 Chemical Requirements

Element	Composition Limits, %				
	Alloy N10001	Alloy N10665	Alloy N10675	Alloy N10629	Alloy N10624
Nickel	remainder <sup>A</sup>	remainder <sup>A</sup>	65.0 min	remainder <sup>A</sup>	Bal
Molybdenum	26.0–30.0	26.0–30.0	27.0–32.0	26.0–30.0	21.0–25.0
Iron	4.0–6.0	2.0 max	1.0–3.0	1.0–6.0	5.0–8.0
Chromium	1.0 max	1.0 max	1.0–3.0	0.5–1.5	6.0–10.0
Carbon, max	0.05	0.02	0.01	0.01	0.01
Silicon, max	1.0	0.10	0.10	0.05	0.10
Cobalt, max	2.5	1.00	3.0	2.5	1.0
Manganese, max	1.0	1.0	3.0	1.5	1.0
Phosphorus, max	0.04	0.04	0.030	0.04	0.025
Sulfur, max	0.03	0.03	0.010	0.01	0.01
Vanadium	0.2–0.4	...	0.20 max	...	...
Nickel plus Molybdenum	...	...	94.0–98.0	...	...
Aluminum	...	...	0.50 max	0.1–0.5	0.5
Columbium (Nb), max	...	...	0.20	...	...
Copper, max	...	...	0.20	0.5	0.5
Tantalum, max	...	...	0.20	...	...
Titanium, max	...	...	0.20	...	...
Tungsten, max	...	...	3.0	...	...
Zirconium, max	...	...	0.10	...	...
Magnesium, max	...	...	...	...	...

<sup>A</sup> See Specification B906.

5.1.4 *Certification*—State if certification or a report of test results is required (Specification B906, Section 21),

5.1.5 *Purchase Inspection*—State which tests or inspections are to be witnessed (Specification B906, Section 18), and

5.1.6 *Samples for Product (Check) Analysis*—State whether samples should be furnished (Specification B906, Section 7.2.2).

## 6. Chemical Composition

6.1 The material shall conform to the composition limits specified in Table 1.

6.2 If a product (check) analysis is made by the purchaser, the material shall conform to the requirements specified in Table 1 and Specification B906.

## 7. Mechanical Properties and Other Requirements

7.1 *Tensile Properties*—The material shall conform to the room temperature tensile properties prescribed in Table 2.

7.2 *Hardness*—The hardness values given in Table 2 are informative only.

7.3 *Grain Size for Sheet and Strip*—Sheet and strip shall conform to the grain sizes as illustrated in Plate 1 of Test Methods E112. The requirements shall be as indicated in Table 3.

## 8. Dimensions, Mass, and Permissible Variations

8.1 *Weight*—For calculations of mass or weight, the following densities shall be used:

Alloy	lb/in. <sup>3</sup>	Density (g/cm <sup>3</sup> )
N10001	0.334	(9.24)
N10665	0.333	(9.22)
N10675	0.333	(9.22)
N10629	0.333	(9.22)
N10624	0.322	(8.9)

8.2 *Thickness*:

8.2.1 *Sheet and Strip*—The thickness shall be measured with the micrometer spindle  $\frac{3}{8}$  in. (9.525 mm) or more from any edge for material 1 in. (25.4 mm) or over in width and at any place on material under 1 in. (25.4 mm) in width.

8.3 *Length*:

8.3.1 *Sheet and Strip*—Sheet and strip may be ordered to cut lengths, in which case a variation of  $\frac{1}{8}$  in. (3.175 mm) over the specified length shall be permitted, with a 0 minus tolerance.

8.4 *Straightness*:

8.4.1 The edgewise curvature (depth of chord) of flat sheet, strip, and plate shall not exceed 0.05 in. (1.27 mm) multiplied by the length in feet or 0.04 mm multiplied by the length in centimetres.

8.4.2 Straightness for coiled strip is subject to agreement between the manufacturer and the purchaser.

8.5 *Squareness (Sheet)*—For sheets of all thicknesses and widths of 6 in. (152.4 mm) or more, the angle between adjacent sides shall be  $90 \pm 0.15$  degrees ( $\frac{1}{16}$  in. in 24 in. or 2.6 mm/m).

8.6 *Flatness*—Plate, sheet, and strip shall be commercially flat.

8.7 *Edges*:

8.7.1 Plates shall have sheared, abrasive cut, or plasma-torch-cut edges as specified.

8.7.2 Sheet and strip shall have sheared or slit edges.

## 9. Product Marking

9.1 Each plate, sheet, or strip shall be marked on one face with the specification number, alloy, heat number, manufacturer's identification, and size. The markings shall have no deleterious effect on the material or its performance and shall be sufficiently stable to withstand normal handling.

9.2 Each bundle or shipping container shall be marked with the name of the material; this specification number; alloy; the size; gross, tare, and net weight; consignor and consignee address; contract or order number; and such other information as may be defined in the contract or order.

## 10. Keywords

10.1 plate; sheet; strip; UNS N10001; UNS N10629; UNS N10665; UNS N10675; UNS N10624

TABLE 2 Mechanical Property Requirements

Alloy	Thickness, in. (mm)	Tensile Strength, min, psi (MPa)	Yield Strength (0.2 % Offset), min, psi (MPa)	Elongation in 2 in. (50.8 mm) or $4D^A$ min, %	Rockwell Hardness, <sup>B</sup> max
		Sheet and Strip			
N10001	Under $\frac{3}{16}$ (4.76)	115 000 (795)	50 000 (345)	45	100 HRB
N10665	Under $\frac{3}{16}$ (4.76)	110 000 (760)	51 000 (350)	40	100 HRB
N10675	Under $\frac{3}{16}$ (4.76)	110 000 (760)	51 000 (350)	40	100 HRB
N10629	Under $\frac{3}{16}$ (4.76)	110 000 (760)	51 000 (350)	40	100 HRB
N10624	Under $\frac{3}{16}$ (4.76)	104 000 (720)	46 000 (320)	40	100 HRB
		Plate			
N10001	$\frac{3}{16}$ to $2\frac{1}{2}$ in. (4.76 to 63.5 mm), incl	100 000 (690)	45 000 (310)	40	100 HRB
N10665	$\frac{3}{16}$ to $2\frac{1}{2}$ in. (4.76 to 63.5 mm), incl	110 000 (760)	51 000 (350)	40	100 HRB
N10675	$\frac{3}{16}$ to $2\frac{1}{2}$ in. (4.76 to 63.5 mm), incl	110 000 (760)	51 000 (350)	40	100 HRB
N10629	$\frac{3}{16}$ to $2\frac{1}{2}$ in. (4.76 to 63.5 mm), incl	110 000 (760)	51 000 (350)	40	100 HRB
N10624	$\frac{3}{16}$ to $2\frac{1}{2}$ in. (4.76 to 63.5 mm), incl	104 000 (720)	46 000 (320)	40	100 HRB

<sup>A</sup>  $D$  refers to the diameter of the tension specimen.

<sup>B</sup> Hardness values are shown for information purposes only and are not to be used as a basis for rejection or acceptance. For approximate hardness conversions, see Hardness Conversion Tables E140.

TABLE 3 Grain Size for Annealed Sheet

Thickness, in. (mm)	ASTM Micrograin Size Number, max	Average Grain Diameter, max, mm (in.)
0.125 (3.175) and under	3.0	0.127 (0.0050)
Over 0.125 (3.175)	1.5	0.214 (0.0084)

## APPENDIX

### (Nonmandatory Information)

#### X1. HEAT TREATMENT

X1.1 Proper heat treatment during or subsequent to fabrication is necessary for optimum performance, and the manufacturer shall be consulted for details.

# SPECIFICATION FOR NICKEL-MOLYBDENUM ALLOY ROD



**SB-335**

(Identical with ASTM Specification B335-03(2018) except that certification and a test report have been made mandatory.)

# Specification for Nickel-Molybdenum Alloy Rod

## 1. Scope

1.1 This specification covers rod of nickel-molybdenum alloys (UNS N10001, N10665, N10675, N10629, and N10624) as shown in Table 1, for use in general corrosive service.

1.2 The following products are covered under this specification:

1.2.1 Rods  $\frac{5}{16}$  to  $\frac{3}{4}$  in. (7.94 to 19.05 mm) excl in diameter, hot or cold finished, solution annealed and pickled or mechanically descaled.

1.2.2 Rods  $\frac{3}{4}$  to  $3\frac{1}{2}$  in. (19.05 to 88.9 mm) incl in diameter, hot or cold finished, solution annealed, ground or turned.

1.3 The values stated in inch-pound units are to be regarded as standard. The values given in parentheses are mathematical conversions to SI units that are provided for information only and are not considered standard.

1.4 *This standard does not purport to address all of the safety concerns, if any, associated with its use. It is the responsibility of the user of this standard to become familiar with all hazards including those identified in the appropriate Safety Data Sheet (SDS) for this product/material as provided by the manufacturer, to establish appropriate safety, health, and environmental practices, and determine the applicability of regulatory limitations prior to use.*

1.5 *This international standard was developed in accordance with internationally recognized principles on standardization established in the Decision on Principles for the Development of International Standards, Guides and Recommendations issued by the World Trade Organization Technical Barriers to Trade (TBT) Committee.*

## 2. Referenced Documents

### 2.1 ASTM Standards:

B880 Specification for General Requirements for Chemical Check Analysis Limits for Nickel, Nickel Alloys and Cobalt Alloys

E8/E8M Test Methods for Tension Testing of Metallic Materials

E29 Practice for Using Significant Digits in Test Data to Determine Conformance with Specifications

E55 Practice for Sampling Wrought Nonferrous Metals and Alloys for Determination of Chemical Composition

E1473 Test Methods for Chemical Analysis of Nickel, Cobalt and High-Temperature Alloys

## 3. Terminology

### 3.1 Definitions of Terms Specific to This Standard:

3.1.1 *rod, n*—a product of round solid section furnished in straight lengths.

## 4. Ordering Information

4.1 It is the responsibility of the purchaser to specify all requirements that are necessary for material ordered under this specification. Examples of such requirements include, but are not limited to the following:

4.1.1 *Alloy*—Table 1.

4.1.2 *Dimensions*—Nominal diameter and length. The shortest usable multiple length shall be specified (Table 2).

4.1.3 *Certification*—State if certification or a report of test results is required (Section 16).

4.1.4 *Purchaser Inspection*—State which tests or inspections are to be witnessed (Section 13).

4.1.5 *Samples for Product (Check) Analysis*—State whether samples should be furnished (9.2.2).

## 5. Chemical Composition

5.1 The material shall conform to the composition limits specified in Table 1.

TABLE 1 Chemical Requirements

Element	Composition Limits, %				
	Alloy N10001	Alloy N10665	Alloy N10675	Alloy N10629	Alloy N10624
Nickel	remainder <sup>A</sup>	remainder <sup>A</sup>	65.0 min	remainder <sup>A</sup>	Bal
Molybdenum	26.0–30.0	26.0–30.0	27.0–32.0	26.0–30.0	21.0–25.0
Iron	4.0–6.0	2.0 max	1.0–3.0	1.0–6.0	5.0–8.0
Chromium	1.0 max	1.0 max	1.0–3.0	0.5–1.5	6.0–10.0
Carbon, max	0.05	0.02	0.01	0.01	0.01
Silicon, max	1.0	0.10	0.10	0.05	0.10
Cobalt, max	2.5	1.00	3.0	2.5	1.0
Manganese, max	1.0	1.0	3.0	1.5	1.0
Phosphorus, max	0.04	0.04	0.030	0.04	0.025
Sulfur, max	0.03	0.03	0.010	0.01	0.01
Vanadium	0.2–0.4	...	0.20 max	...	...
Nickel plus Molybdenum	...	...	94.0–98.0	...	...
Aluminum	...	...	0.50 max	0.1–0.5	0.5
Columbium (Nb), max	...	...	0.20	...	...
Copper, max	...	...	0.20	0.5	0.5
Tantalum, max	...	...	0.20	...	...
Titanium, max	...	...	0.20	...	...
Tungsten, max	...	...	3.0	...	...
Zirconium, max	...	...	0.10	...	...
Magnesium, max	...	...	...	...	...

<sup>A</sup> See 12.1.

5.2 If a product (check) analysis is made by the purchaser, the material shall conform to the requirements specified in Table 1 subject to the permissible tolerances in B880.

## 6. Mechanical Properties and Other Requirements

6.1 The mechanical properties of the material at room temperature shall conform to those shown in Table 3.

## 7. Dimensions and Permissible Variations

7.1 *Diameter*—The permissible variations from the specified diameter shall be as prescribed in Table 2.

7.2 *Out of Roundness*—The permissible variation in roundness shall be as prescribed in Table 2.

7.3 *Machining Allowances*—When the surfaces of finished material are to be machined, the following allowances are suggested for normal machining operations.

7.3.1 *As-finished (Annealed and Descaled)*—For diameters of  $\frac{5}{16}$  to  $\frac{1}{16}$  in. (7.94 to 17.46 mm) incl., an allowance of  $\frac{1}{16}$  in. (1.59 mm) on the diameter should be made for finish machining.

### 7.4 Length:

7.4.1 Unless multiple, nominal, or cut lengths are specified, random mill lengths shall be furnished.

7.4.2 The permissible variations in length of multiple, nominal, or cut length rod shall be as prescribed in Table 4. Where rods are ordered in multiple lengths, a  $\frac{1}{4}$ -in. (6.35-mm) length addition shall be allowed for each uncut multiple length.

### 7.5 Ends:

7.5.1 Rods ordered to random or nominal lengths shall be furnished with either cropped or sawed ends.

7.5.2 Rods ordered to cut lengths shall be furnished with square saw-cut or machined ends.

7.6 *Weight*—For calculations of mass or weight, the following densities shall be used:

Alloy	lb/in <sup>3</sup>	Density	
		lb/in <sup>3</sup>	g/cm <sup>3</sup>
N10001	0.334		9.24
N10665	0.333		9.22
N10675	0.333		9.22
N10629	0.333		9.22
N10624	0.322		8.9

7.7 *Straightness*—The maximum curvature (depth of chord) shall not exceed 0.050 in. multiplied by the length of the chord in feet (0.04 mm multiplied by the length in centimetres).

## 8. Workmanship, Finish, and Appearance

8.1 The material shall be uniform in quality and condition, smooth, and free of injurious imperfections.

## 9. Sampling

### 9.1 Lots for Chemical Analysis and Mechanical Testing:

9.1.1 A lot for chemical analysis shall consist of one heat.

9.1.2 A lot of bar for mechanical testing shall be defined as the material from one heat in the same condition and specified diameter.

### 9.2 Sampling for Chemical Analysis:

9.2.1 A representative sample shall be obtained from each heat during pouring or subsequent processing.

9.2.2 Product (check) analysis shall be wholly the responsibility of the purchaser.

### 9.3 Sampling for Mechanical Testing:

9.3.1 A representative sample shall be taken from each lot of finished material.

## 10. Number of Tests and Retests

10.1 *Chemical Analysis*—One test per heat.

10.2 *Tension Tests*—One test per lot.

10.3 *Retests*—If the specimen used in the mechanical test of any lot fails to meet the specified requirements, two additional specimens shall be taken from different sample pieces and tested. The results of the tests on both of these specimens shall meet the specified requirements.

## 11. Specimen Preparation

11.1 Tension test specimens shall be taken from material after final heat-treatment and tested in the direction of fabrication.

11.2 Tension test specimens shall be any of the standard or subsized specimens shown in Test Methods E8/E8M.

11.3 In the event of disagreement, the referee specimen shall be the largest possible round specimen shown in Test Methods E8/E8M.

## 12. Test Methods

12.1 The chemical composition and mechanical properties of the material as enumerated in this specification shall be

TABLE 2 Permissible Variations in Diameter and Out-of-Roundness of Finished Rods

Specified Diameter, in. (mm)	Permissible Variations, in. (mm)		
	Diameter		Out of Roundness, max
	Plus	Minus	
Hot-Finished, Annealed, and Descaled Rods			
5/16 to 7/16 (7.94–11.11), incl	0.012 (0.30)	0.012 (0.30)	0.018 (0.46)
Over 7/16 to 5/8 (11.11–15.87), incl	0.014 (0.36)	0.014 (0.36)	0.020 (0.51)
Over 5/8 to 3/4 (15.87–19.05), excl	0.016 (0.41)	0.016 (0.41)	0.024 (0.61)
Hot-Finished, Annealed, and Ground or Turned Rods			
3/4 to 3 1/2 (19.05–88.9), incl	0.010 (0.25)	0	0.008 (0.20)

TABLE 3 Mechanical Properties

Alloy	Thickness, in. (mm)	Tensile Strength, min, psi (MPa)	Yield Strength (0.2 % Offset), min, psi (MPa)	Elongation in 2 in. (50 mm) or 4D <sup>A</sup> , min %	Rockwell Hardness, max
N10001	5/16 to 1 1/2 (7.94 to 38.1) incl	115 000 (795)	46 000 (315)	35	
	Over 1 1/2 to 3 1/2 (38.1 to 88.9) incl	100 000 (690)	46 000 (315)	30	
N10665	5/16 to 3 1/2 (7.94 to 88.9) incl	110 000 (760)	51 000 (350)	40	
N10675	5/16 to 3 1/2 (7.94 to 88.9) incl	110 000 (760)	51 000 (350)	40	
N10629	5/16 to 3 1/2 (7.94 to 88.9) incl	110 000 (760)	51 000 (350)	40	100 HRB
N10624	5/16 to 3 1/2 in. (7.94 to 88.9 mm), incl	104 000 (720)	46 000 (320)	40	100 HRB

<sup>A</sup> D refers to the diameter of the tension specimen.

TABLE 4 Permissible Variations in Length of Rods

Random mill lengths	2 to 12 ft (610 to 3660 mm) long with not more than 25 weight % under 4 ft (1.22 m).
Multiple lengths	Furnished in multiples of a specified unit length, within the length limits indicated above. For each multiple, an allowance of 1/4 in. (6.35 mm) shall be made for cutting, unless otherwise specified. At the manufacturer's option, individual specified unit lengths may be furnished.
Nominal lengths	Specified nominal lengths having a range of not less than 2 ft (610 mm) with no short lengths allowed.
Cut lengths	A specified length to which all rods shall be cut with a permissible variation of + 1/8 in. (3.17 mm) – 0.

determined, in case of disagreement, in accordance with the following ASTM methods:

12.1.1 *Chemical Analysis*—Test Methods E1473. For elements not covered by Test Methods E1473, the referee method shall be as agreed upon between the manufacturer and the purchaser. The nickel composition shall be determined arithmetically by difference.

12.1.2 *Tension Test*—Test Methods E8/E8M.

12.1.3 *Method of Sampling*—Practice E55.

12.1.4 *Determining Significant Places*—Practice E29.

12.2 For purposes of determining compliance with the limits in this specification, an observed value or a calculated value shall be rounded as indicated below, in accordance with the rounding method of Practice E29:

Requirements	Rounded Unit for Observed or Calculated Value
Chemical composition and tolerance	Nearest unit in the last right-hand place of figures of the specified limit
Tensile strength and yield strength	nearest 1000 psi (7 MPa)
Elongation	nearest 1 %

### 13. Inspection

13.1 Inspection of the material shall be made as agreed upon by the manufacturer and the purchaser as part of the purchase contract.

### 14. Rejection and Rehearing

14.1 Material tested by the purchaser that fails to conform to the requirements of this specification may be rejected. Rejection should be reported to the producer or supplier promptly and in writing. In case of dissatisfaction with the results of the test, the producer or supplier may make claim for a rehearing.

### 15. Certification

15.1 A manufacturer's certification shall be furnished to the purchaser stating that material has been manufactured, tested, and inspected in accordance with this specification, and that the test results on representative samples meet specification requirements. A report of the test results shall be furnished.

### 16. Product Marking

16.1 Each piece of material 1/2 in. (12.7 mm) and over in diameter shall be marked with the specification number, alloy, heat number, manufacturer's identification, and size. The markings shall have no deleterious effect on the material or its performance and shall be sufficiently stable to withstand normal handling.

16.2 Each bundle or shipping container shall be marked with the name of the material; this specification number; alloy; the size; gross, tare, and net weight; consignor and consignee address; contract or order number; and such other information as may be defined in the contract or order.

### 17. Keywords

17.1 rod; N10001; N10624; N10629; N10665; N10675

**APPENDIX****(Nonmandatory Information)****X1. HEAT TREATMENT**

X1.1 Proper heat treatment during or subsequent to fabrication is necessary for optimum performance, and the manufacturer shall be consulted for details.

ASMENORMDOC.COM : Click to view the full PDF of ASME BPVC.II.B (ASME BPVC Section II part B) 2025

ASMENORMDOC.COM : Click to view the full PDF of ASME BPVC.II.B (ASME BPVC Section II part B) 2025

INTENTIONALLY LEFT BLANK

# SPECIFICATION FOR SEAMLESS AND WELDED TITANIUM AND TITANIUM ALLOY TUBES FOR CONDENSERS AND HEAT EXCHANGERS



**SB-338**



(Identical with ASTM Specification B338-17. For editions prior to 08a, certification and test reports are mandatory, and product marking shall also show ASME designation.)

# Specification for Seamless and Welded Titanium and Titanium Alloy Tubes for Condensers and Heat Exchangers

## 1. Scope

1.1 This specification covers the requirements for 28 grades of titanium and titanium alloy tubing intended for surface condensers, evaporators, and heat exchangers, as follows:

- 1.1.1 *Grade 1*—UNS R50250. Unalloyed titanium,
- 1.1.2 *Grade 2*—UNS R50400. Unalloyed titanium,
  - 1.1.2.1 *Grade 2H*—UNS R50400. Unalloyed titanium (Grade 2 with 58 ksi (400 MPa) minimum UTS),
- 1.1.3 *Grade 3*—UNS R50550. Unalloyed titanium,
- 1.1.4 *Grade 7*—UNS R52400. Unalloyed titanium plus 0.12 to 0.25 % palladium,
  - 1.1.4.1 *Grade 7H*—UNS R52400. Unalloyed titanium plus 0.12 to 0.25 % palladium (Grade 7 with 58 ksi (400 MPa) minimum UTS),
- 1.1.5 *Grade 9*—UNS R56320. Titanium alloy (3 % aluminum, 2.5 % vanadium),
- 1.1.6 *Grade 11*—UNS R52250. Unalloyed titanium plus 0.12 to 0.25 % palladium,
- 1.1.7 *Grade 12*—UNS R53400. Titanium alloy (0.3 % molybdenum, 0.8 % nickel),
- 1.1.8 *Grade 13*—UNS R53413. Titanium alloy (0.5 % nickel, 0.05 % ruthenium),
- 1.1.9 *Grade 14*—UNS R53414. Titanium alloy (0.5 % nickel, 0.05 % ruthenium),
- 1.1.10 *Grade 15*—UNS R53415. Titanium alloy (0.5 % nickel, 0.05 % ruthenium),
- 1.1.11 *Grade 16*—UNS R52402. Unalloyed titanium plus 0.04 to 0.08 % palladium,
  - 1.1.11.1 *Grade 16H*—UNS R52402. Unalloyed titanium plus 0.04 to 0.08 % palladium (Grade 16 with 58 ksi (400 MPa) minimum UTS),

1.1.12 *Grade 17*—UNS R52252. Unalloyed titanium plus 0.04 to 0.08 % palladium,

1.1.13 *Grade 18*—UNS R56322. Titanium alloy (3 % aluminum, 2.5 % vanadium) plus 0.04 to 0.08 % palladium,

1.1.14 *Grade 26*—UNS R52404. Unalloyed titanium plus 0.08 to 0.14 % ruthenium,

1.1.14.1 *Grade 26H*—UNS R52404. Unalloyed titanium plus 0.08 to 0.14 % ruthenium (Grade 26 with 58 ksi (400 MPa) minimum UTS),

1.1.15 *Grade 27*—UNS R52254. Unalloyed titanium plus 0.08 to 0.14 % ruthenium,

1.1.16 *Grade 28*—UNS R56323. Titanium alloy (3 % aluminum, 2.5 % vanadium) plus 0.08 to 0.14 % ruthenium,

1.1.17 *Grade 30*—UNS R53530. Titanium alloy (0.3 % cobalt, 0.05 % palladium),

1.1.18 *Grade 31*—UNS R53532. Titanium alloy (0.3 % cobalt, 0.05 % palladium),

1.1.19 *Grade 33*—UNS R53442. Titanium alloy (0.4 % nickel, 0.015 % palladium, 0.025 % ruthenium, 0.15 % chromium),

1.1.20 *Grade 34*—UNS R53445. Titanium alloy (0.4 % nickel, 0.015 % palladium, 0.025 % ruthenium, 0.15 % chromium),

1.1.21 *Grade 35*—UNS R56340. Titanium alloy (4.5 % aluminum, 2 % molybdenum, 1.6 % vanadium, 0.5 % iron, 0.3 % silicon),

1.1.22 *Grade 36*—UNS R58450. Titanium alloy (45 % niobium),

1.1.23 *Grade 37*—UNS R52815. Titanium alloy (1.5 % aluminum),

1.1.24 *Grade 38*—UNS R54250. Titanium alloy (4 % aluminum, 2.5 % vanadium, 1.5 % iron), and

1.1.25 *Grade 39*—UNS R53390. Titanium alloy (0.25 % iron, 0.4 % silicon).

NOTE 1—H grade material is identical to the corresponding numeric grade (that is, Grade 2H = Grade 2) except for the higher guaranteed minimum UTS, and may always be certified as meeting the requirements of its corresponding numeric grade. Grades 2H, 7H, 16H, and 26H are intended primarily for pressure vessel use.

1.2 The values stated in inch-pound units are to be regarded as standard. The values given in parentheses are mathematical

conversions to SI units that are provided for information only and are not considered standard.

1.3 *This international standard was developed in accordance with internationally recognized principles on standardization established in the Decision on Principles for the Development of International Standards, Guides and Recommendations issued by the World Trade Organization Technical Barriers to Trade (TBT) Committee.*

## 2. Referenced Documents

### 2.1 ASTM Standards:

- A370 Test Methods and Definitions for Mechanical Testing of Steel Products
- E8 Test Methods for Tension Testing of Metallic Materials
- E29 Practice for Using Significant Digits in Test Data to Determine Conformance with Specifications
- E213 Practice for Ultrasonic Testing of Metal Pipe and Tubing
- E426 Practice for Electromagnetic (Eddy Current) Examination of Seamless and Welded Tubular Products, Titanium, Austenitic Stainless Steel and Similar Alloys
- E499 Test Methods for Leaks Using the Mass Spectrometer Leak Detector in the Detector Probe Mode
- E1409 Test Method for Determination of Oxygen and Nitrogen in Titanium and Titanium Alloys by Inert Gas Fusion
- E1447 Test Method for Determination of Hydrogen in Titanium and Titanium Alloys by Inert Gas Fusion Thermal Conductivity/Infrared Detection Method
- E1941 Test Method for Determination of Carbon in Refractory and Reactive Metals and Their Alloys by Combustion Analysis
- E2371 Test Method for Analysis of Titanium and Titanium Alloys by Direct Current Plasma and Inductively Coupled Plasma Atomic Emission Spectrometry (Performance-Based Test Methodology)
- E2626 Guide for Spectrometric Analysis of Reactive and Refractory Metals (Withdrawn 2017)

## 3. Terminology

### 3.1 Lot Definitions:

3.1.1 *castings, n*—a lot shall consist of all castings produced from the same pour.

3.1.2 *ingot, n*—no definition required.

3.1.3 *rounds, flats, tubes, and wrought powder metallurgical products (single definition, common to nuclear and non-nuclear standards), n*—a lot shall consist of a material of the same size, shape, condition, and finish produced from the same ingot or powder blend by the same reduction schedule and the same heat treatment parameters. Unless otherwise agreed between manufacturer and purchaser, a lot shall be limited to

the product of an 8 h period for final continuous anneal, or to a single furnace load for final batch anneal.

3.1.4 *sponge, n*—a lot shall consist of a single blend produced at one time.

3.1.5 *weld fittings, n*—definition is to be mutually agreed upon between manufacturer and the purchaser.

## 4. Ordering Information

4.1 Orders for material to this specification shall include the following information, as required:

- 4.1.1 Quantity,
- 4.1.2 Grade number (Section 1),
- 4.1.3 Diameter and wall thickness (Note 2) (Section 12),
- 4.1.4 Length (Section 12),
- 4.1.5 Method of manufacture and finish (Sections 5 and 13),
- 4.1.6 Restrictive chemistry, if desired (Section 6 and Table 1),
- 4.1.7 Product analysis, if desired (Section 7 and Table 2),
- 4.1.8 Special mechanical properties, if desired (Section 8 and Table 3),
- 4.1.9 Nondestructive tests (Section 11),
- 4.1.10 Packaging (Section 23),
- 4.1.11 Inspection (Section 17), and
- 4.1.12 Certification (Section 21).

NOTE 2—Tube is available to specified outside diameter and wall thickness. Average OD and wall are the standard. Maximum or minimum OD or wall should be stated.

4.2 Optional supplementary requirements are provided and, when one or more of these are desired, each shall be so stated in the order.

## 5. Materials and Manufacture

5.1 Seamless tube shall be made from hollow billet by any cold reducing or cold drawing process that will yield a product meeting the requirements of this specification. Seamless tube is produced with a continuous periphery in all stages of manufacturing operations.

5.2 Welded tube shall be made from annealed, flat-rolled product by an automatic arc-welding process or other method of welding that will yield a product meeting the tensile requirements found in Table 3 of this specification. Welded tubing shall be heat treated by at least a stress relief after forming and welding. Use of filler material is not permitted.

5.3 Welded/cold worked tube (WCS) shall be made from welded tube manufactured as specified in 5.2. The welded tube shall be sufficiently cold worked to final size in order to transform the cast weld microstructure into a typical equiaxed microstructure in the weld upon subsequent heat treatment. The product shall meet the requirements for seamless tube of this specification.

5.4 Grades 9, 18 and 28, which, at the option of the purchaser, can be furnished in either the annealed or the cold worked and stress relieved condition, defined as at a minimum temperature of 600°F (316°C) for not less than 30 min.

**TABLE 1 Chemical Requirements**

Composition, Weight Percent<sup>A,B,C,D,E</sup>

Grade	UNS Number	Carbon, max.	Oxygen range or max.	Nitrogen, max.	Hydrogen, max.	Iron range or max.	Aluminum	Vanadium	Palladium	Ruthenium	Nickel	Molybdenum	Chromium	Cobalt	Zirconium	Niobium	Tin	Silicon	Other Elements, max. each	Other Elements, max. total
1	R50250	0.08	0.18	0.03	0.015	0.20	--	--	--	--	--	--	--	--	--	--	--	--	0.1	0.4
2/2H	R50400	0.08	0.25	0.03	0.015	0.30	--	--	--	--	--	--	--	--	--	--	--	--	0.1	0.4
3	R50550	0.08	0.35	0.05	0.015	0.30	--	--	--	--	--	--	--	--	--	--	--	--	0.1	0.4
--	--	--	--	--	--	--	--	--	--	--	--	--	--	--	--	--	--	--	--	--
7/7H	R52400	0.08	0.25	0.03	0.015	0.30	--	--	0.12-0.25	--	--	--	--	--	--	--	--	--	0.1	0.4
9	R56320	0.08	0.15	0.03	0.015	0.25	2.5-3.5	2.0-3.0	--	--	--	--	--	--	--	--	--	--	0.1	0.4
11	R52250	0.08	0.18	0.03	0.015	0.20	--	--	0.12-0.25	--	--	--	--	--	--	--	--	--	0.1	0.4
12	R53400	0.08	0.25	0.03	0.015	0.30	--	--	--	--	0.6-0.9	0.2-0.4	--	--	--	--	--	--	0.1	0.4
13	R53413	0.08	0.10	0.03	0.015	0.20	--	--	--	0.04-0.06	0.4-0.6	--	--	--	--	--	--	--	0.1	0.4
14	R53414	0.08	0.15	0.03	0.015	0.30	--	--	--	0.04-0.06	0.4-0.6	--	--	--	--	--	--	--	0.1	0.4
15	R53415	0.08	0.25	0.05	0.015	0.30	--	--	--	0.04-0.06	0.4-0.6	--	--	--	--	--	--	--	0.1	0.4
16/16H	R52402	0.08	0.25	0.03	0.015	0.30	--	--	0.04-0.08	--	--	--	--	--	--	--	--	--	0.1	0.4
17	R52252	0.08	0.18	0.03	0.015	0.20	--	--	0.04-0.08	--	--	--	--	--	--	--	--	--	0.1	0.4
18	R56322	0.08	0.15	0.03	0.015	0.25	2.5-3.5	2.0-3.0	0.04-0.08	--	--	--	--	--	--	--	--	--	0.1	0.4
--	--	--	--	--	--	--	--	--	--	--	--	--	--	--	--	--	--	--	--	--
--	--	--	--	--	--	--	--	--	--	--	--	--	--	--	--	--	--	--	--	--
--	--	--	--	--	--	--	--	--	--	--	--	--	--	--	--	--	--	--	--	--
26/26H	R52404	0.08	0.25	0.03	0.015	0.30	--	--	--	0.08-0.14	--	--	--	--	--	--	--	--	0.1	0.4
27	R52254	0.08	0.18	0.03	0.015	0.20	--	--	--	0.08-0.14	--	--	--	--	--	--	--	--	0.1	0.4
28	R56323	0.08	0.15	0.03	0.015	0.25	2.5-3.5	2.0-3.0	--	0.08-0.14	--	--	--	--	--	--	--	--	0.1	0.4
--	--	--	--	--	--	--	--	--	--	--	--	--	--	--	--	--	--	--	--	--
31	R53532	0.08	0.35	0.05	0.015	0.30	--	--	0.04-0.08	--	--	--	--	0.20-0.80	--	--	--	--	0.1	0.4
--	--	--	--	--	--	--	--	--	--	--	--	--	--	--	--	--	--	--	--	--
33	R53442	0.08	0.25	0.03	0.015	0.30	--	--	0.01-0.02	0.02-0.04	0.35-0.55	--	0.1-0.2	--	--	--	--	--	0.1	0.4
34	R53445	0.08	0.35	0.05	0.015	0.30	--	--	0.01-0.02	0.02-0.04	0.35-0.55	--	0.1-0.2	--	--	--	--	--	0.1	0.4
35	R56340	0.08	0.25	0.05	0.015	0.20-0.80	4.0-5.0	1.1-2.1	--	--	--	1.5-2.5	--	--	--	--	--	0.20-0.40	0.1	0.4
36	R58450	0.04	0.16	0.03	0.015	0.03	--	--	--	--	--	--	--	--	--	42.0-47.0	--	--	0.1	0.4
37	R52815	0.08	0.25	0.03	0.015	0.30	1.0-2.0	--	--	--	--	--	--	--	--	--	--	--	0.1	0.4

ASMENORMS.COM: Click to view the full PDF of ASME BPVC.II.B (ASME BPVC Section II part B) 2025

TABLE 1 Continued

Composition, Weight Percent<sup>A,B,C,D,E</sup>

Grade	UNS Number	Carbon, max.	Oxygen range or max.	Nitrogen, max.	Hydrogen, max.	Iron range or max.	Aluminum	Vanadium	Palladium	Ruthenium	Nickel	Molybdenum	Chromium	Cobalt	Zirconium	Niobium	Tin	Silicon	Other Elements, max. each	Other Elements, max. total
38	R54250	0.08	0.20-0.30	0.03	0.015	1.2-1.8	3.5-4.5	2.0-3.0	--	--	--	--	--	--	--	--	--	--	0.1	0.4
39	R53390	0.08	0.15	0.03	0.015	0.15-0.40	—	—	—	—	—	—	—	—	—	—	—	0.30-0.50	0.1	0.4

<sup>A</sup> At minimum, the analysis of samples from the top and bottom of the ingot shall be completed and reported for all elements listed for the respective grade in this table.

<sup>B</sup> Final product hydrogen shall be reported. Ingot hydrogen need not be reported. Lower hydrogen may be obtained by negotiation with the manufacturer.

<sup>C</sup> Single values are maximum. The percentage of titanium is determined by difference.

<sup>D</sup> Other elements need not be reported unless the concentration level is greater than 0.1 % each, or 0.4 % total. Other elements may not be added intentionally. Other elements may be present in titanium or titanium alloys in small quantities and are inherent to the manufacturing process. In titanium these elements typically include aluminum, vanadium, tin, chromium, molybdenum, niobium, zirconium, hafnium, bismuth, ruthenium, palladium, yttrium, copper, silicon, cobalt, tantalum, nickel, boron, manganese, and tungsten.

<sup>E</sup> The purchaser may, in the written purchase order, request analysis for specific elements not listed in this specification.

TABLE 2 Permissible Variations in Product Analysis

Element	%	
	Maximum or Specified Range	Permissible Variation in Product Analysis
Aluminum	0.5 to 2.5	±0.20
Aluminum	2.5 to 3.5	±0.40
Carbon	0.10	+0.02
Chromium	0.1 to 0.2	±0.02
Cobalt	0.2 to 0.8	±0.05
Hydrogen	0.015	+0.002
Iron	0.80	+0.15
Iron	1.2 to 1.8	±0.20
Molybdenum	0.2 to 0.4	±0.03
Molybdenum	1.5 to 4.5	±0.20
Nickel	0.3 to 0.9	±0.05
Niobium	>30	±0.50
Nitrogen	0.05	+0.02
Oxygen	0.30	+0.03
Oxygen	0.31 to 0.40	±0.04
Palladium	0.01 to 0.02	±0.002
Palladium	0.04 to 0.25	±0.02
Ruthenium	0.02 to 0.04	±0.005
Ruthenium	0.04 to 0.06	±0.005
Ruthenium	0.08 to 0.14	±0.01
Silicon	0.06 to 0.50	±0.02
Vanadium	2.0 to 3.0	±0.15
Residuals <sup>A</sup> (each)	0.1	+0.02

<sup>A</sup> A residual is an element present in a metal or an alloy in small quantities inherent to the manufacturing process but not added intentionally. In titanium these elements include aluminum, vanadium, tin, iron, chromium, molybdenum, niobium, zirconium, hafnium, bismuth, ruthenium, palladium, yttrium, copper, silicon, cobalt, tantalum, nickel, boron, manganese, and tungsten.

## 6. Chemical Requirements

6.1 The titanium shall conform to the chemical requirements prescribed in Table 1.

6.1.1 The elements listed in Table 1 are intentional alloy additions or elements that are inherent to the manufacture of titanium sponge, ingot, or mill product.

6.1.2 Elements intentionally added to the melt must be identified, analyzed, and reported in the chemical analysis.

6.2 When agreed upon by the producer and the purchaser and requested by the purchaser in the written purchase order, chemical analysis shall be completed for specific residual elements not listed in this specification.

## 7. Product Analysis

7.1 When requested by the purchaser and stated in the purchase order, product analysis for any elements listed in Table 1 shall be made on the completed product.

7.1.1 Elements other than those listed in Table 1 are deemed to be capable of occurring in the grades listed in Table 1 by, and only by way of, unregulated or unanalyzed scrap additions to the ingot melt. Therefore, product analysis for elements not listed in Table 1 shall not be required unless specified and shall be considered to be in excess of the intent of this specification.

7.2 Product analysis tolerances, listed in Table 2, do not broaden the specified heat analysis requirements, but cover variations between different laboratories in the measurement of chemical content. The manufacturer shall not ship the finished product that is outside the limits specified in Table 1 for the applicable grade.

## 8. Tensile Requirements

8.1 The room temperature tensile properties of the tube in the condition normally supplied shall conform to the requirements prescribed in Table 3. Mechanical properties for conditions other than those given in this table may be established by agreement between the manufacturer and the purchaser. (See Test Methods E8.)

## 9. Flattening Test

9.1 Tubing shall withstand, without cracking, flattening under a load applied gradually at room temperature until the distance between the load platens is not more than  $H$  in.  $H$  is calculated as follows:

$$H, \text{ in. (mm)} = \frac{(1+e)t}{e+t/D} \quad (1)$$

where:

$H$  = the minimum flattened height, in. (mm),  
 $t$  = the nominal wall thickness, in. (mm), and  
 $D$  = the nominal tube diameter, in. (mm).

For Grades 1, 2, 2H, 7, 7H, 11, 13, 14, 16, 16H, 17, 26, 26H, 27, 30, 33, and 39:

$$e = 0.07 \text{ in. for all diameters} \quad (2)$$

For Grade 3, 31, and 34:

$$e = 0.04 \text{ through 1 in. diameter} \quad (3)$$

$$e = 0.06 \text{ over 1 in. diameter} \quad (4)$$

For Grades 9, 12, 15, 18, 28, 35, 36, 37, and 38:

$e$  shall be negotiated between the producer and the purchaser.

9.1.1 For welded tubing, the weld shall be positioned on the 90 or 270° centerline during loading so as to be subjected to a maximum stress.

9.1.2 When low D-to-t ratio tubular products are tested, because the strain imposed due to geometry is unreasonably high on the inside surface at the six and twelve o'clock locations, cracks at these locations shall not be cause for rejection if the D-to-t ratio is less than ten (10).

9.2 The results from all calculations are to be rounded to two decimal places. Examination for cracking shall be by the unaided eye.

9.3 Welded tube shall be subjected to a reverse flattening test in accordance with Annex 2 of Test Methods and Definitions A370. A section of the tube, approximately 4 in. (102 mm) long, that is slit longitudinally 90° either side of the weld, shall be opened and flattened with the weld at the point of maximum bend. No cracking is permitted.

## 10. Flaring Test

10.1 For tube 3½ in. (88 mm) in outside diameter and smaller, and 0.134 in. (3.4 mm) in wall thickness and thinner, a section of tube approximately 4 in. (102 mm) in length shall withstand being flared with a tool having a 60° included angle until the tube at the mouth of the flare has been expanded in accordance with Table 4. The flared end shall show no cracking or rupture visible to the unaided eye. Flaring tests on larger

TABLE 3 Tensile Requirements

Grade	Tensile Strength, min		Yield Strength, 0.2 % Offset				Elongation in 2 in. or 50 mm, min, %
	ksi	MPa	min		max		
			ksi	MPa	ksi	MPa	
1 <sup>A</sup>	35	240	20	138	45	310	24
2 <sup>A</sup>	50	345	40	275	65	450	20
2H <sup>A,B,C</sup>	58	400	40	275	65	450	20
3 <sup>A</sup>	65	450	55	380	80	550	18
7 <sup>A</sup>	50	345	40	275	65	450	20
7H <sup>A,B,C</sup>	58	400	40	275	65	450	20
9 <sup>D</sup>	125	860	105	725	...	...	10
9 <sup>A</sup>	90	620	70	483	...	...	15 <sup>E</sup>
11 <sup>A</sup>	35	240	20	138	45	310	24
12 <sup>A</sup>	70	483	50	345	...	...	18 <sup>E</sup>
13 <sup>A</sup>	40	275	25	170	...	...	24
14 <sup>A</sup>	60	410	40	275	...	...	20
15 <sup>A</sup>	70	483	55	380	...	...	18
16 <sup>A</sup>	50	345	40	275	65	450	20
16H <sup>A,B,C</sup>	58	400	40	275	65	450	20
17 <sup>A</sup>	35	240	20	138	45	310	24
18 <sup>D</sup>	125	860	105	725	...	...	10
18 <sup>A</sup>	90	620	70	483	...	...	15 <sup>E</sup>
26	50	345	40	275	65	450	20
26H <sup>A,B,C</sup>	58	400	40	275	65	450	20
27	35	240	20	138	45	310	24
28	90	620	70	483	...	...	15
30	50	345	40	275	65	450	20
31	65	450	55	380	80	550	18
33	50	345	40	275	65	450	20
34	65	450	55	380	80	550	18
35	130	895	120	828	...	...	5
36	65	450	60	410	95	655	10
37	50	345	31	215	65	450	20
38	130	895	115	794	...	...	10
39	75	515	60	410	90	620	20

<sup>A</sup> Properties for material in the annealed condition.

<sup>B</sup> Material is identical to the corresponding numeric grade (that is, Grade 2H = Grade 2) except for the higher guaranteed minimum UTS, and may always be certified as meeting the requirements of its corresponding numeric grade. Grade 2H, 7H, 16H, and 26H are intended primarily for pressure vessel use.

<sup>C</sup> The H grades were added in response to a user association request based on its study of over 5200 commercial Grade 2, 7, 16, and 26 test reports, where over 99 % met the 58 ksi minimum UTS.

<sup>D</sup> Properties for cold-worked and stress-relieved material.

<sup>E</sup> Elongation for welded tubing manufactured from continuously cold rolled and annealed strip from coils for Grades 9, 12, and 18 will be 12 %.

TABLE 4 Flaring Requirements

Grade	Expansion of Inside Diameter, min, %
1	22
2, 2H	20
3	17
7, 7H	20
9 <sup>A</sup>	20
11	22
12	17
13	22
14	20
15	17
16, 16H	20
17	22
18 <sup>A</sup>	20
26, 26H	20
27	22
28 <sup>A</sup>	20
30	20
31	17
33	20
34	17
35	10
37	20
38	15
39	20

<sup>A</sup> Annealed.

diameter tube or tubing outside the range of Table 4 shall be as agreed upon between the manufacturer and the purchaser.

11. Nondestructive Tests

11.1 *Welded Tubes* shall be nondestructively tested using the following procedures:

11.1.1 Eddy Current Test, see 11.3.

11.1.2 Ultrasonic Test, see 11.4.1.1.

11.1.3 Hydrostatic Test, see 11.6, or pneumatic test, see 11.7.

11.2 *Seamless and Welded/Cold Worked Tubes* shall be nondestructively tested using the following procedures:

11.2.1 Ultrasonic Test, see 11.4.1.2.

11.2.2 Eddy Current Test, see 11.3, or hydrostatic test, see 11.6, or pneumatic test, see 11.7.

11.3 *Eddy Current Test:*

11.3.1 Perform the nondestructive test in accordance with Practice E426. The entire volume of the tube shall be tested.

11.3.1.1 *Drilled Hole*—The calibration tube shall contain three or more holes, equally spaced circumferentially around the tube and longitudinally separated by a sufficient distance to allow distinct identification of the signal from each hole. The

holes shall be drilled radially and completely through the tube wall, with care being taken to avoid distortion of the tube while drilling. The holes shall not be larger than 0.031 in (0.787 mm) in diameter. As an alternative, the producer may choose to drill one hole and run the calibration standard through the test coil three times, rotating the tube approximately 120° each time. More passes with smaller angular increments may be used, provided testing of the full 360° of the coil is obtained. For welded tubing, one of the multiple holes or the single hole may be drilled in the weld. As an option, the single hole may be drilled in the skelp.

11.4 *Ultrasonic Testing:*

11.4.1 Perform the nondestructive test in accordance with Practice E213.

11.4.1.1 *Welded Tubing*—A longitudinal notch 0.031 in. (0.787 mm) or less in width and 0.5 in. (12.7 mm) or less in length shall be machined on a radial parallel to the tube axis on the outside and inside of the tube. The notch depth shall not exceed 10 % of the nominal wall of the tube or 0.004 in. (0.102 mm), whichever is greater. The length of the notch shall be compatible with the testing method, and the notches shall be located 180 degrees from the weld. The entire volume of the tube shall be tested.

11.4.1.2 *Seamless and Welded/Cold Worked Tubing*—Longitudinal and transverse notches not exceeding 0.010 in. (0.25 mm) in width and 10 % of the nominal tube wall or 0.004 in. (0.102 mm), whichever is greater, in depth shall be machined on the inner and outer surfaces of the tube. The length of the notches shall not exceed 0.125 in. (3.18 mm).

11.5 Any tubes showing an indication in excess of that obtained from the calibration standard shall be set aside and be subject to rework, retest, or rejection. A tube thus set aside may be examined further for confirmation of the presence of a defect and may be resubmitted for inspection if no defect is found. Any tube may also be resubmitted for inspection if reworked so as to remove the defect within the specified diameter, and wall thickness tolerances are established from Table 5 (rework by weld repair is not permitted).

11.6 *Hydrostatic Test:*

11.6.1 Each tube so tested shall withstand, without showing bulges, leaks, or other defects, an internal hydrostatic pressure that will produce in the tube wall a stress of 50 % of the minimum specified yield strength at room temperature. This pressure shall be determined by the equation:

$$P = \frac{SEt}{R_o - 0.4t} \tag{5}$$

where:

- P* = minimum hydrostatic test pressure, psi (or MPa),
- S* = allowable fiber stress of one half the minimum yield strength, psi (or MPa),
- t* = wall thickness, in. (or mm),
- R<sub>o</sub>* = outside tube radius, in. (or mm),
- E* = 0.85 welded tube, and
- E* = 1.0 seamless and welded/cold worked tube.

11.6.2 The maximum hydrostatic test pressure shall not exceed 2500 psi (17.2 MPa) for sizes 3 in. (76 mm) and under, or 2800 psi (19.3 MPa) for sizes over 3 in. Hydrostatic pressure shall be maintained for not less than 5 s. When requested by the purchaser and so stated in the order, tube in sizes 14 in. (356 mm) in diameter and smaller shall be tested to one and one half times the specified working pressure, provided the fiber stress corresponding to those test pressures does not exceed one half the minimum specified yield strength of the material as determined by the equation given in 11.3. When one and one half times the working pressure exceeds 2800 psi (19.3 MPa), the hydrostatic test pressure shall be a matter of agreement between the manufacturer and purchaser.

11.7 *Pneumatic Test*—Each tube so tested shall withstand an internal air pressure of 100 psi (0.69 MPa), minimum, for 5 s, minimum, without showing evidence of leakage. The test method used shall permit easy detection of any leakage by using the pressure differential method or by placing the tube under water. Any evidence of leakage shall be cause for rejection of that tube.

12. **Permissible Variation in Dimensions**

12.1 Variations in dimensions from those specified shall not exceed the amounts prescribed in Table 5.

12.2 *Length*—When tube is ordered cut to length, the length shall not be less than that specified, but a variation of 1/8 in. (3.2 mm) will be permitted on tube up to 24 ft (7.3 m) inclusive. For lengths over 24 ft (7.3 m), an additional over tolerance of 1/8 in. (3.2 mm) for each 10 ft (3.05 m) or fraction thereof shall be permissible up to 1/2 in. (13 mm) maximum.

12.3 *Straightness*—The tube shall be free of bends or kinks, and the maximum uniform bow shall not exceed the values given in Table 6.

**TABLE 5 Permissible Variations in Outside Dimensions Based on Individual Measurements**

Outside Diameter, in. (mm)	Diameter Tolerance, in. (mm) <sup>A,B,C</sup>	Permissible Variations <sup>D</sup> in Wall Thickness, <i>t</i> , %
Under 1 (25.4), excl	±0.004 (±0.102)	±10
1 to 1½ (25.4 to 38.1), excl	±0.005 (±0.127)	±10
1½ to 2 (38.1 to 50.8), excl	±0.006 (±0.152)	±10
2 to 2½ (50.8 to 63.5), excl	±0.007 (±0.178)	±10
2½ to 3½ (63.5 to 88.9), excl	±0.010 (±0.254)	±10

<sup>A</sup> These permissible variations in outside diameter apply only to tubes as finished at the mill before subsequent swaging, expanding, bending, polishing, or other fabricating operations.

<sup>B</sup> When minimum diameter tubes are ordered, tolerances are all on the plus side and shall be double the values shown.

<sup>C</sup> When maximum diameter tubes are ordered, tolerances are all on the minus side and shall be double the values shown.

<sup>D</sup> When minimum wall tubes are ordered, tolerances are all plus and shall be double the values shown.

**TABLE 6 Straightness**

Length, ft (m)	Maximum Curvature Depth of Arc
Over 3 to 6 (0.91 to 1.83), incl	1/8 in. (3.2 mm)
Over 6 to 8 (1.83 to 2.44), incl	3/16 in. (4.8 mm)
Over 8 to 10 (2.44 to 3.05), incl	1/4 in. (6.4 mm)
Over 10 (3.05)	1/4 in./any 10 ft (2.1 mm/m)

12.4 *Squareness of Cut*—The angle of cut of the end of any tube may depart from square by not more than 0.016 in./in. of diameter.

#### 12.5 *Outside Diameter:*

12.5.1 *Welded Tubes*—The outside diameter of welded tubes shall not vary from that specified by more than the amounts given in Table 5 as measured by “go” and “no go” ring gages. The dimensions of the ring gage shall be as described in 12.5.1.1. For tube diameters not listed in Table 5, the dimensional tolerances shall be as agreed upon by the purchaser and the manufacturer or supplier.

12.5.1.1 The inside diameter dimension of the “go” ring gage shall be equal to the nominal tube diameter plus the plus tolerance plus 0.002 in. The length of the “go” ring gage shall be the larger of 1 in. (25.4 mm) or the tube diameter.

12.5.1.2 The inside diameter dimension of the “no go” ring gage shall be equal to the nominal tube diameter minus the minus tolerance. The length of the “no go” ring gage shall be the larger of 1 in. or the nominal tube diameter.

12.5.2 *Seamless and Welded/Cold Worked Tubes*—The outside diameter of seamless and welded/cold worked tubes shall not vary from that specified by more than the amounts given in Table 5 as measured by any method agreed upon between the purchaser and the manufacturer or supplier. For tube diameters not listed in Table 5, the dimensional tolerances shall be as agreed upon by the purchaser and the manufacturer or supplier.

### 13. Finish

13.1 The finished tube shall be clean and free of foreign material, shall have smooth ends free of burrs, and shall be free of injurious external and internal imperfections. Minor defects may be removed, provided the dimensional tolerances of Section 12 are not exceeded.

### 14. Number of Tests

14.1 One sample shall be selected from lots of 5000 ft (1600 m) or less. For lots greater than 5000 ft (1600 m), one sample shall be selected from the first 5000 ft (1600 m), and one additional sample shall be selected from each additional 5000 ft (1600 m) or less in the lot. Samples are to be selected at random, and in no case shall more than one sample be taken from a single tube length. The size of the lot may be either the manufactured lot or the purchased lot at the manufacturer’s option.

14.1.1 Chemical composition of the lot shall be the ingot manufacturer’s analysis, except for hydrogen, which shall be determined on each sample from the lot. For welded tube only, hydrogen determination shall be one (1) tube analysis per strip coil.

14.1.2 One tension test shall be made on each sample.

14.1.3 One flattening test in accordance with 9.1 shall be made on each sample.

14.1.4 One reverse flattening test in accordance with 9.3 shall be made on each sample.

14.1.5 One flaring test in accordance with 10.1 shall be made on each sample.

14.2 If any test specimen shows defective machining or develops flaws due to preparation, the specimen may be discarded and another substituted.

14.3 If the percent of elongation of any tension test specimen is less than that specified in 8.1, and any part of the fracture is more than  $\frac{3}{4}$  in. (19 mm) from the center of the gage length as indicated by scratches marked on the specimen before testing, the specimen may be discarded and another substituted.

14.4 Each length of finished tube shall be examined by the nondestructive test specified in 11.1.

### 15. Retests

15.1 If the results of any chemical or mechanical property test lot are not in conformance with the requirements of this specification, the lot may be retested at the option of the manufacturer. The frequency of the retest will double the initial number of tests. If the results of the retest conform to the specification, the retest values will become the test values for certification. Only original conforming test results or the conforming retest results shall be reported to the purchaser. If the results for the retest fail to conform to the specification, the material will be rejected in accordance with Section 20.

### 16. Test Specimens and Methods of Testing

16.1 The test specimens and the tests required by this specification shall conform to those described in Test Methods and Definitions A370.

16.2 All routine mechanical tests shall be made at room temperature.

16.3 The chemical analysis shall normally be conducted using the ASTM standard test methods referenced in 2.1. Other industry standard methods may be used where the ASTM test methods referenced in 2.1 do not adequately cover the elements in the material or by agreement between the producer and purchaser. Alternate techniques are discussed in Guide E2626.

### 17. Inspection

17.1 All tests and inspection required by this specification shall be made at the place of manufacture prior to shipment and at the manufacturer’s expense unless otherwise specified, and shall be so conducted as not to interfere unnecessarily with the operation of the works. When specified in the order, the manufacturer shall notify the purchaser in time so that the purchaser may have his inspector present to witness any part of the tests that may be desired.

17.2 When agreed upon in writing between the manufacturer and the purchaser, a certification that the material conforms to the requirements of this specification shall be the basis for acceptance of the material. Otherwise, the manufacturer shall report to the purchaser or his representative the results of the chemical analyses and mechanical tests made in accordance with this specification.

### 18. Rounding-Off Procedure

18.1 For purposes of determining conformance with the specifications contained herein, an observed or calculated

value shall be rounded off to the nearest "unit" in the last right-hand significant digit used in expressing the limiting value. This is in accordance with the round-off method of Practice E29.

### 19. Referee Test and Analysis

19.1 In the event of disagreement between the manufacturer and the purchaser on the conformance of the material to the requirements of this specification, a mutually acceptable referee shall perform the tests in question using the ASTM standard methods in 2.1. The referee's testing shall be used in determining conformance of the material to this specification.

### 20. Rejection

20.1 Material not conforming to this specification or to authorized modifications shall be subject to rejection. Unless otherwise specified, rejected material may be returned to the manufacturer at the manufacturer's expense, unless the purchaser receives within 3 weeks of notice of rejection other instructions for disposition.

### 21. Certification

21.1 The manufacturer shall supply at least one copy of the report certifying that the material supplied has been manufactured, inspected, sampled, and tested in accordance with the requirements of this specification and that the results

of chemical analysis, tensile, and other tests meet the requirements of this specification for the grade specified. The report shall include results of all chemical analysis, tensile tests, and all other tests required by the specification.

### 22. Product Marking

22.1 Each length of tube  $\frac{1}{2}$  in. (13 mm) in outside diameter and larger, manufactured in accordance with this specification, shall be legibly marked, either by stenciling, stamping, or rolling, with the manufacturer's private identifying mark, the ASTM designation, the tube class, the grade, and heat number. On smaller than  $\frac{1}{2}$  in. outside diameter tubing that is bundled, the same information may be legibly stamped on a metal tag securely attached to each bundle.

NOTE 3—Average outside diameter and wall thickness are the standard for this specification. If maximum or minimum OD or wall are ordered, the tubes should be marked accordingly.

### 23. Packaging and Package Marking

23.1 The tube shall be packaged in accordance with the manufacturer's standard practice, unless otherwise agreed upon between the manufacturer and the purchaser and so stated in the purchase order.

### 24. Keywords

24.1 seamless tubing; titanium; titanium alloy; tubing; welded/cold worked tubing; welded tubing

## SUPPLEMENTARY REQUIREMENTS

The following supplementary requirements become part of the specification when specified in the purchase order or contract.

### S1. Traverse Ultrasonic Test (Welded Tubing)

S1.1 A transverse notch 0.031 in. (0.787 mm) or less in width and 0.5 in. (12.7 mm) or less in length shall be machined on a radial perpendicular to the tube axis on the outside and inside of the tube in addition to the longitudinal notch. The notch depth shall not exceed 10 % of the nominal wall of the tube or 0.004 in. (0.102 mm), whichever is greater. Perform the nondestructive test in accordance with Practice E213.

### S2. Helium Leak Test (Welded Tubing)

S2.1 The tubing shall be tested by the helium leak test according to Practice E499 in substitution of the pneumatic test required in 11.7. The maximum allowable leak rate shall be  $9.87 \times 10^{-4}$  std cm<sup>3</sup>/s (1 x 10<sup>-3</sup> mbar l/s) quantified with a calibrated leak.

# SPECIFICATION FOR TITANIUM AND TITANIUM ALLOY BARS AND BILLETS



**SB-348/SB-348M**

(Identical with ASTM Specification B348/B348M-19 except that Note A of Table 2 has been revised.)

ASMENORMDOC.COM : Click to view the full PDF of ASME BPVC.II.B (ASME BPVC Section II part B) 2025

## Specification for Titanium and Titanium Alloy Bars and Billets

### 1. Scope

1.1 This specification covers annealed titanium and titanium alloy bars and billets as follows:

1.1.1 *Grade 1*—UNS R50250. Unalloyed titanium,

1.1.2 *Grade 2*—UNS R50400. Unalloyed titanium,

1.1.2.1 *Grade 2H*—UNS R50400. Unalloyed titanium (Grade 2 with 58 ksi [400 MPa] minimum UTS),

1.1.3 *Grade 3*—UNS R50550. Unalloyed titanium,

1.1.4 *Grade 4*—UNS R50700. Unalloyed titanium,

1.1.5 *Grade 5*—UNS R56400. Titanium alloy (6 % aluminum, 4 % vanadium),

1.1.6 *Grade 6*—UNS R54520. Titanium alloy (5 % aluminum, 2.5 % tin),

1.1.7 *Grade 7*—UNS R52400. Unalloyed titanium plus 0.12 to 0.25 % palladium,

1.1.7.1 *Grade 7H*—UNS R52400. Unalloyed titanium plus 0.12 to 0.25 % palladium (Grade 7 with 58 ksi [400 MPa] minimum UTS),

1.1.8 *Grade 9*—UNS R56320. Titanium alloy (3 % aluminum, 2.5 % vanadium),

1.1.9 *Grade 11*—UNS R52250. Unalloyed titanium plus 0.12 to 0.25 % palladium,

1.1.10 *Grade 12*—UNS R53400. Titanium alloy (0.3 % molybdenum, 0.8 % nickel),

1.1.11 *Grade 13*—UNS R53413. Titanium alloy (0.5 % nickel, 0.05 % ruthenium),

1.1.12 *Grade 14*—UNS R53414. Titanium alloy (0.5 % nickel, 0.05 % ruthenium),

1.1.13 *Grade 15*—UNS R53415. Titanium alloy (0.5 % nickel, 0.05 % ruthenium),

1.1.14 *Grade 16*—UNS R52402. Unalloyed titanium plus 0.04 to 0.08 % palladium,

1.1.14.1 *Grade 16H*—UNS R52402. Unalloyed titanium plus 0.04 to 0.08 % palladium (Grade 16 with 58 ksi [400 MPa] minimum UTS),

1.1.15 *Grade 17*—UNS R52252. Unalloyed titanium plus 0.04 to 0.08 % palladium,

1.1.16 *Grade 18*—UNS R56322. Titanium alloy (3 % aluminum, 2.5 % vanadium) plus 0.04 to 0.08 % palladium,

1.1.17 *Grade 19*—UNS R58640. Titanium alloy (3 % aluminum, 8 % vanadium, 6 % chromium, 4 % zirconium, 4 % molybdenum),

1.1.18 *Grade 20*—UNS R58645. Titanium alloy (3 % aluminum, 8 % vanadium, 6 % chromium, 4 % zirconium, 4 % molybdenum) plus 0.04 %–0.08 % palladium,

1.1.19 *Grade 21*—UNS R58210. Titanium alloy (15 % molybdenum, 3 % aluminum, 2.7 % niobium, 0.25 % silicon),

1.1.20 *Grade 23*—UNS R56407. Titanium alloy (6 % aluminum, 4 % vanadium with extra low interstitial elements, ELI),

1.1.21 *Grade 24*—UNS R56405. Titanium alloy (6 % aluminum, 4 % vanadium) plus 0.04 % to 0.08 % palladium,

1.1.22 *Grade 25*—UNS R56403. Titanium alloy (6 % aluminum, 4 % vanadium) plus 0.3 % to 0.8 % nickel and 0.04 % to 0.08 % palladium,

1.1.23 *Grade 26*—UNS R52404. Unalloyed titanium plus 0.08 to 0.14 % ruthenium,

1.1.23.1 *Grade 26H*—UNS R52404. Unalloyed titanium plus 0.08 to 0.14 % ruthenium (Grade 26 with 58 ksi [400 MPa] minimum UTS),

1.1.24 *Grade 27*—UNS R52254. Unalloyed titanium plus 0.08 to 0.14 % ruthenium,

1.1.25 *Grade 28*—UNS R56323. Titanium alloy (3 % aluminum, 2.5 % vanadium plus 0.08–0.14 % ruthenium),

1.1.26 *Grade 29*—UNS R56404. Titanium alloy (6 % aluminum, 4 % vanadium, extra low interstitial, ELI plus 0.08 to 0.14 % ruthenium),

1.1.27 *Grade 30*—UNS R53530. Titanium alloy (0.3 % cobalt, 0.05 % palladium),

1.1.28 *Grade 31*—UNS R53532. Titanium alloy (0.3 % cobalt, 0.05 % palladium),

1.1.29 *Grade 32*—UNS R55111. Titanium alloy (5 % aluminum, 1 % tin, 1 % zirconium, 1 % vanadium, 0.8 % molybdenum),

1.1.30 *Grade 33*—UNS R53442. Titanium alloy (0.4 % nickel, 0.015 % palladium, 0.025 % ruthenium, 0.15 % chromium),

1.1.31 *Grade 34*—UNS R53445. Titanium alloy (0.4 % nickel, 0.015 % palladium, 0.025 % ruthenium, 0.15 % chromium),

1.1.32 *Grade 35*—UNS R56340. Titanium alloy (4.5 % aluminum, 2 % molybdenum, 1.6 % vanadium, 0.5 % iron, 0.3 % silicon),

1.1.33 *Grade 36*—UNS R58450. Titanium alloy (45 % niobium),

1.1.34 *Grade 37*—UNS R52815. Titanium alloy (1.5 % aluminum), and

1.1.35 *Grade 38*—UNS R54250. Titanium alloy (4 % aluminum, 2.5 % vanadium, 1.5 % iron).

NOTE 1—H grade material is identical to the corresponding numeric grade (that is, Grade 2H = Grade 2) except for the higher guaranteed minimum UTS, and may always be certified as meeting the requirements of its corresponding numeric grade. Grades 2H, 7H, 16H, and 26H are intended primarily for pressure vessel use.

1.2 The values state in either inch-pound units or SI units are to be regarded separately as standard. The values stated in each system are not exact equivalents; therefore, each system shall be used independently of the other. Combining values from the two systems may result in nonconformance with the specification.

1.3 *This international standard was developed in accordance with internationally recognized principles on standardization established in the Decision on Principles for the Development of International Standards, Guides and Recommendations issued by the World Trade Organization Technical Barriers to Trade (TBT) Committee.*

## 2. Referenced Documents

### 2.1 ASTM Standards:

E8/E8M Test Methods for Tension Testing of Metallic Materials

E29 Practice for Using Significant Digits in Test Data to Determine Conformance with Specifications

E539 Test Method for Analysis of Titanium Alloys by Wavelength Dispersive X-Ray Fluorescence Spectrometry

E1409 Test Method for Determination of Oxygen and Nitrogen in Titanium and Titanium Alloys by Inert Gas Fusion

E1447 Test Method for Determination of Hydrogen in Titanium and Titanium Alloys by Inert Gas Fusion Thermal Conductivity/Infrared Detection Method

E1941 Test Method for Determination of Carbon in Refractory and Reactive Metals and Their Alloys by Combustion Analysis

E2371 Test Method for Analysis of Titanium and Titanium Alloys by Direct Current Plasma and Inductively Coupled Plasma Atomic Emission Spectrometry (Performance-Based Test Methodology)

E2626 Guide for Spectrometric Analysis of Reactive and Refractory Metals (Withdrawn 2017)

E2994 Test Method for Analysis of Titanium and Titanium Alloys by Spark Atomic Emission Spectrometry and Glow Discharge Atomic Emission Spectrometry (Performance-Based Method)

## 3. Terminology

### 3.1 Definitions of Terms Specific to This Standard:

3.1.1 *bar, n*—a hot rolled, forged, extruded or cold worked semi-finished solid section product whose cross sectional area is equal to or less than 16 in.<sup>2</sup> [10 323 mm<sup>2</sup>]; rectangular bar must be less than or equal to 10 in. [254 mm] in width and greater than 0.1875 in. [4.8 mm] in thickness.

3.1.1.1 *Discussion*—Extruded bar has been approved for use on unalloyed titanium grades 1, 2, 3 and 4 only. Other grades may be produced via the extrusion process with agreement between the producer and the purchaser.

3.1.2 *billet, n*—a solid semi-finished section hot worked or forged from an ingot, with a cross sectional area greater than 16 in.<sup>2</sup> [10 323 mm<sup>2</sup>] whose width is less than five times its thickness.

3.1.3 *heat analysis*—chemical determination based on analysis of ingot or alternate (see Table 1 footnote A, and 9.2); check analysis limits do not apply for Heat Analysis/Producer Ingot Analysis

3.1.4 *product analysis*—an analysis based on semi-finished or final product; the purchaser may apply check analysis limits to determine compliance with the specification; check analysis limits are not for producer's use at producer ingot acceptance.

3.1.5 *check analysis limits*—Table 3, Permissible Variations in Product Analysis: Percentages above and below those listed in Table 1, when tested on product, by or for the purchaser, or acceptable to purchaser to show compliance with a given specification.

## 4. Ordering Information

4.1 Orders for material under this specification shall include the following information as applicable:

4.1.1 Grade number (Section 1),

4.1.2 Product classification (Section 3),

4.1.3 Chemistry (Table 1),

4.1.4 Condition required for Grades 9, 18, 20, 21, 23, 28, and 29.

4.1.5 Mechanical properties (Table 2),

4.1.6 Marking (Section 16),

4.1.7 Finish (Section 8),

4.1.8 Packaging (Section 16),

4.1.9 Required reports (Section 15), and

4.1.10 Disposition of rejected material (Section 14).

## 5. Chemical Composition

5.1 The grades of titanium and titanium alloy metal covered by this specification shall conform to the requirements as to chemical composition prescribed in Table 1.

5.1.1 The elements listed in Table 1 are intentional alloy additions or elements which are inherent to the manufacture of titanium sponge, ingot or mill product.

5.1.1.1 Elements other than those listed in Table 1 are deemed to be capable of occurring in the grades listed in Table

TABLE 1 Chemical Requirements

Composition, Weight Percent<sup>A,B,C,D,E</sup>

Grade	UNS Number	Carbon, max.	Oxygen range or max.	Nitrogen, max.	Hydrogen, max.	Iron range or max.	Aluminum	Vanadium	Palladium	Ruthenium	Nickel	Molybdenum	Chromium	Cobalt	Zirconium	Niobium	Tin	Silicon	Other Elements, max. each	Other Elements, max. total
1	R50250	0.08	0.18	0.03	0.015	0.20	--	--	--	--	--	--	--	--	--	--	--	--	0.1	0.4
2/2H	R50400	0.08	0.25	0.03	0.015	0.30	--	--	--	--	--	--	--	--	--	--	--	--	0.1	0.4
3	R50550	0.08	0.35	0.05	0.015	0.30	--	--	--	--	--	--	--	--	--	--	--	--	0.1	0.4
4	R50700	0.08	0.40	0.05	0.015	0.50	--	--	--	--	--	--	--	--	--	--	--	--	0.1	0.4
5	R56400	0.08	0.20	0.05	0.015	0.40	5.5-6.75	3.5-4.5	--	--	--	--	--	--	--	--	--	--	0.1	0.4
6	R54520	0.08	0.20	0.03	0.015	0.50	4.0-6.0	--	--	--	--	--	--	--	--	--	2.0-3.0	--	0.1	0.4
7/7H	R52400	0.08	0.25	0.03	0.015	0.30	--	--	0.12-0.25	--	--	--	--	--	--	--	--	--	0.1	0.4
9	R56320	0.08	0.15	0.03	0.015	0.25	2.5-3.5	2.0-3.0	--	--	--	--	--	--	--	--	--	--	0.1	0.4
11	R52250	0.08	0.18	0.03	0.015	0.20	--	--	0.12-0.25	--	--	--	--	--	--	--	--	--	0.1	0.4
12	R53400	0.08	0.25	0.03	0.015	0.30	--	--	--	--	0.6-0.9	0.2-0.4	--	--	--	--	--	--	0.1	0.4
13	R53413	0.08	0.10	0.03	0.015	0.20	--	--	--	0.04-0.06	0.4-0.6	--	--	--	--	--	--	--	0.1	0.4
14	R53414	0.08	0.15	0.03	0.015	0.30	--	--	--	0.04-0.06	0.4-0.6	--	--	--	--	--	--	--	0.1	0.4
15	R53415	0.08	0.25	0.05	0.015	0.30	--	--	--	0.04-0.06	0.4-0.6	--	--	--	--	--	--	--	0.1	0.4
16/16H	R52402	0.08	0.25	0.03	0.015	0.30	--	--	0.04-0.08	--	--	--	--	--	--	--	--	--	0.1	0.4
17	R52252	0.08	0.18	0.03	0.015	0.20	--	--	0.04-0.08	--	--	--	--	--	--	--	--	--	0.1	0.4
18	R56322	0.08	0.15	0.03	0.015	0.25	2.5-3.5	2.0-3.0	0.04-0.08	--	--	--	--	--	--	--	--	--	0.1	0.4
19	R58640	0.05	0.12	0.03	0.02	0.30	3.0-4.0	7.5-8.5	--	--	--	3.5-4.5	5.5-6.5	--	3.5-4.5	--	--	--	0.15	0.4
20	R58645	0.05	0.12	0.03	0.02	0.30	3.0-4.0	7.5-8.5	0.04-0.08	--	--	3.5-4.5	5.5-6.5	--	3.5-4.5	--	--	--	0.15	0.4
21	R58210	0.05	0.17	0.03	0.015	0.40	2.5-3.5	--	--	--	--	4.5-14.0	6.5--	--	--	2.2-3.2	--	0.15-0.25	0.1	0.4
23	R56407	0.08	0.13	0.03	0.0125	0.25	5.5-6.5	3.5-4.5	--	--	--	--	--	--	--	--	--	--	0.1	0.4
24	R56405	0.08	0.20	0.05	0.015	0.40	5.5-6.75	3.5-4.5	0.04-0.08	--	--	--	--	--	--	--	--	--	0.1	0.4
25	R56403	0.08	0.20	0.05	0.015	0.40	5.5-6.75	3.5-4.5	0.04-0.08	--	0.3-0.8	--	--	--	--	--	--	--	0.1	0.4
26/26H	R52404	0.08	0.25	0.03	0.015	0.30	--	--	--	0.08-0.14	--	--	--	--	--	--	--	--	0.1	0.4
27	R52254	0.08	0.18	0.03	0.015	0.20	--	--	--	0.08-0.14	--	--	--	--	--	--	--	--	0.1	0.4
28	R56323	0.08	0.15	0.03	0.015	0.25	2.5-3.5	2.0-3.0	--	0.08-0.14	--	--	--	--	--	--	--	--	0.1	0.4
29	R56404	0.08	0.13	0.03	0.0125	0.25	5.5-6.5	3.5-4.5	--	0.08-0.14	--	--	--	--	--	--	--	--	0.1	0.4
30	R53530	0.08	0.25	0.03	0.015	0.30	--	--	0.04-0.08	--	--	--	--	0.20-0.80	--	--	--	--	0.1	0.4
31	R53532	0.08	0.35	0.05	0.015	0.30	--	--	0.04-0.08	--	--	--	--	0.20-0.80	--	--	--	--	0.1	0.4

ASMENORMS.COM Click to view the full PDF of ASME BPVC.II.B (ASME BPVC Section II part B) 2025

ASMENORMDOC.COM : Click to view the full PDF of ASME BPVC.II.B (ASME BPVC Section II part B) 2025

**TABLE 1** *Continued*

Composition, Weight Percent<sup>A,B,C,D,E</sup>

Grade	UNS Number	Carbon, max.	Oxygen range or max.	Nitrogen, max.	Hydrogen, max.	Iron range or max.	Aluminum	Vanadium	Palladium	Ruthenium	Nickel	Molybdenum	Chromium	Cobalt	Zirconium	Niobium	Tin	Silicon	Other Elements, max. each	Other Elements, max. total
32	R55111	0.08	0.11	0.03	0.015	0.25	4.5-5.5	0.6-1.4	--	--	--	0.6-1.2	--	--	0.6-1.4	--	0.6-1.4	0.06-0.14	0.1	0.4
33	R53442	0.08	0.25	0.03	0.015	0.30	--	--	0.01-0.02	0.02-0.04	0.35-0.55	--	0.1-0.2	--	--	--	--	--	0.1	0.4
34	R53445	0.08	0.35	0.05	0.015	0.30	--	--	0.01-0.02	0.02-0.04	0.35-0.55	--	0.1-0.2	--	--	--	--	--	0.1	0.4
35	R56340	0.08	0.25	0.05	0.015	0.20-0.80	4.0-5.0	1.1-2.1	--	--	--	1.5-2.5	--	--	--	--	--	0.20-0.40	0.1	0.4
36	R58450	0.04	0.16	0.03	0.015	0.03	--	--	--	--	--	--	--	--	--	42.0-47.0	--	--	0.1	0.4
37	R52815	0.08	0.25	0.03	0.015	0.30	1.0-2.0	--	--	--	--	--	--	--	--	--	--	--	0.1	0.4
38	R54250	0.08	0.20-0.30	0.03	0.015	1.2-1.8	3.5-4.5	2.0-3.0	--	--	--	--	--	--	--	--	--	--	0.1	0.4

<sup>A</sup> At minimum, the analysis of samples from the top and bottom of the ingot or of the product from the top and bottom of the ingot shall be completed and reported for all elements listed for the respective grade in this table.

<sup>B</sup> Final product hydrogen shall be reported. Ingot hydrogen need not be reported. Lower hydrogen may be obtained by negotiation with the manufacturer.

<sup>C</sup> Single values are maximum. The percentage of titanium is determined by difference.

<sup>D</sup> Other elements need not be reported unless the concentration level is greater than 0.1 % each, or 0.4 % total. Other elements may not be added intentionally. Other elements may be present in titanium or titanium alloys in small quantities and are inherent to the manufacturing process. In titanium these elements typically include aluminum, vanadium, tin, chromium, molybdenum, niobium, zirconium, hafnium, bismuth, ruthenium, palladium, yttrium, copper, silicon, cobalt, tantalum, nickel, boron, manganese, and tungsten.

<sup>E</sup> The purchaser may, in the written purchase order, request analysis for specific elements not listed in this specification.

TABLE 2 Tensile Requirements<sup>A</sup>

Grade	Tensile Strength, min		Yield Strength (0.2 % Offset) min or range		Elongation in 4D, 4 W or 2 inch min, %	Reduction of Area, min %
	ksi	MPa	ksi	MPa		
1	35	240	20	138	24	30
2	50	345	40	275	20	30
2H <sup>B,C</sup>	58	400	40	275	20	30
3	65	450	55	380	18	30
4	80	550	70	483	15	25
5	130	895	120	828	10	25
6	120	828	115	795	10	25
7	50	345	40	275	20	30
7H <sup>B,C</sup>	58	400	40	275	20	30
9	90	620	70	483	15	25
9 <sup>D</sup>	90	620	70	483	12	25
11	35	240	20	138	24	30
12	70	483	50	345	18	25
13	40	275	25	170	24	30
14	60	410	40	275	20	30
15	70	483	55	380	18	25
16	50	345	40	275	20	30
16H <sup>B,C</sup>	58	400	40	275	20	30
17	35	240	20	138	24	30
18	90	620	70	483	15	25
18 <sup>D</sup>	90	620	70	483	12	20
19 <sup>E</sup>	115	793	110	759	15	25
19 <sup>F</sup>	135	930	130 to 159	897 to 1096	10	20
19 <sup>G</sup>	165	1138	160 to 185	1104 to 1276	5	20
20 <sup>E</sup>	115	793	110	759	15	25
20 <sup>F</sup>	135	930	130 to 159	897 to 1096	10	20
20 <sup>G</sup>	165	1138	160 to 185	1104 to 1276	5	20
21 <sup>E</sup>	115	793	110	759	15	35
21 <sup>F</sup>	140	966	130 to 159	897 to 1096	10	30
21 <sup>G</sup>	170	1172	160 to 185	1104 to 1276	8	20
23	120	828	110	759	10	25
23 <sup>D</sup>	120	828	110	759	7.5 <sup>H</sup> , 6.0 <sup>I</sup>	15
24	130	895	120	828	10	25
25	130	895	120	828	10	25
26	50	345	40	275	20	30
26H <sup>B,C</sup>	58	400	40	275	20	30
27	35	240	20	138	24	30
28	90	620	70	483	15	25
28 <sup>D</sup>	90	620	70	483	12	20
29	120	828	110	759	10	25
29 <sup>D</sup>	120	828	110	759	7.5 <sup>H</sup> , 6.0 <sup>I</sup>	15
30	50	345	40	275	20	30
31	65	450	55	380	18	30
32	100	689	85	586	10	25
33	50	345	40	275	20	30
34	65	450	55	380	18	30
35	130	895	120	828	5	20
36	65	450	60 to 95	410 to 655	10	...
37	50	345	31	215	20	30
38	130	895	115	794	10	25

<sup>A</sup> These properties apply to longitudinal sections up to 3 in. [76 mm] in thickness with a maximum of 10 in.<sup>2</sup> [64.5 cm<sup>2</sup>].  
<sup>B</sup> Material is identical to the corresponding numeric grade (that is, Grade 2H = Grade 2) except for the higher guaranteed minimum UTS, and may always be certified as meeting the requirements of its corresponding numeric grade. Grade 2H, 7H, 16H, and 26H are intended primarily for pressure vessel use.  
<sup>C</sup> The H grades were added in response to a user association request based on its study of over 5200 commercial Grade 2, 7, 16, and 26 test reports, where over 99 % met the 58 ksi minimum UTS.  
<sup>D</sup> Properties for material in transformed-beta condition.  
<sup>E</sup> Properties for solution treated condition.  
<sup>F</sup> Properties for solution treated and aged condition—Moderate strength (determined by aging temperature).  
<sup>G</sup> Properties for solution treated and aged condition—High strength (determined by aging temperature).  
<sup>H</sup> For product section or wall thickness values <1.0 in.  
<sup>I</sup> For product section or wall thickness values ≥ 1.0 in.

1 by and only by way of unregulated or unanalyzed scrap additions to the ingot melt. Therefore, product analysis for elements not listed in Table 1 shall not be required unless specified and shall be considered to be in excess of the intent of this specification.

5.1.2 Elements intentionally added to the melt must be identified, analyzed and reported in the chemical analysis.

TABLE 3 Permissible Variations in Product Analysis

Element	Product Analysis Limits, max or Range, %	Permissible Variation in Product Analysis
Aluminum	0.5 to 2.5	±0.20
Aluminum	2.5 to 6.75	±0.40
Carbon	0.10	+0.02
Chromium	0.1 to 0.2	±0.02
Chromium	5.5 to 6.5	±0.30
Cobalt	0.2 to 0.8	±0.05
Hydrogen	0.02	+0.002
Iron	0.80	+0.15
Iron	1.2 to 1.8	±0.20
Molybdenum	0.2 to 0.4	±0.03
Molybdenum	0.6 to 1.2	±0.15
Molybdenum	1.5 to 4.5	±0.20
Molybdenum	14.0 to 16.0	±0.50
Nickel	0.3 to 0.9	±0.05
Niobium	2.2 to 3.2	±0.15
Niobium	>30	±0.50
Nitrogen	0.05	+0.02
Oxygen	0.30	+0.03
Oxygen	0.31 to 0.40	±0.04
Palladium	0.01 to 0.02	±0.002
Palladium	0.04 to 0.08	±0.005
Palladium	0.12 to 0.25	±0.02
Ruthenium	0.02 to 0.04	±0.005
Ruthenium	0.04 to 0.06	±0.005
Ruthenium	0.08 to 0.14	±0.01
Silicon	0.06 to 0.40	±0.02
Tin	0.62.0 to 3.0	±0.15
Vanadium	0.6 to 4.5	±0.15
Vanadium	7.5 to 8.5	±0.40
Zirconium	0.6 to 1.4	±0.15
Residuals <sup>A</sup> (each)	0.15	+0.02

<sup>A</sup> A residual is an element present in a metal or alloy in small quantities and is inherent to the manufacturing process but not added intentionally. In titanium these elements include aluminum, vanadium, tin, iron, chromium, molybdenum, niobium, zirconium, hafnium, bismuth, ruthenium, palladium, yttrium, copper, silicon, cobalt, tantalum, nickel, boron, manganese, and tungsten.

5.2 When agreed upon by the producer and purchaser and requested by the purchaser in his written purchase order, chemical analysis shall be completed for specific residual elements not listed in this specification.

5.3 *Product Analysis*—Product analysis tolerances do not broaden the specified heat analysis requirements, but cover variations between laboratories in the measurement of chemical content. The ingot manufacturer shall not ship material

which is outside the limits specified in Table 1 for the applicable grade. Product analysis limits shall be as specified in Table 3.

## 6. Mechanical Properties

6.1 Material supplied under this specification shall conform to the mechanical property requirements given in Table 2, as applicable.

6.2 Tension testing specimens are to be machined and tested in accordance with Test Methods E8/E8M. Tensile properties shall be determined using a strain rate of 0.003 to 0.007 in./in./min through the specified yield strength, and then increasing the rate so as to produce failure in approximately one additional minute.

## 7. Dimensions, Weight, and Permissible Variations

7.1 *Size*—Tolerances on titanium and titanium alloy material covered by this specification shall be as specified in Tables 4-11, as applicable.

7.2 *Weight*—Quantity extras are applicable to individual items of a grade, thickness, width, and length ordered at one time for shipment at one time to one destination. Different lengths of the same size and grade may be combined for quantity extra. The shipping weight of any item of an ordered size in any finish may exceed the theoretical weight by as much as 10%.

## 8. Workmanship, Finish, and Appearance

8.1 Titanium and titanium alloy bar and billet shall be free of injurious external and internal imperfections of a nature that will interfere with the purpose for which it is intended. Annealed material may be furnished as descaled, sandblasted, ground, or rough turned. The manufacturer shall be permitted to remove minor surface imperfections by spot grinding if such grinding does not reduce the thickness of the material below the minimum permitted by the tolerance for the thickness ordered.

## 9. Sampling

9.1 Samples for chemical analyses shall be representative of the material being tested. The utmost care must be used in

TABLE 4 Permissible Variations in Size for Titanium Bars—Hot-Worked Rounds and Squares

Specified Size, in. [mm]	Size Variations, in. [mm]	Out-of-Round <sup>A</sup> or Out-of-Square, <sup>B</sup> in. [mm]
1/4 to 5/16 [6.35 to 7.94], incl	±0.005 [0.13]	0.008 [0.20]
Over 5/16 to 7/16 [7.94 to 11.11], incl	±0.006 [0.15]	0.009 [0.23]
Over 7/16 to 1/2 [11.11 to 15.88], incl	±0.007 [0.18]	0.010 [0.25]
Over 1/2 to 3/8 [15.88 to 22.22], incl	±0.008 [0.20]	0.012 [0.30]
Over 3/8 to 1 [22.22 to 25.40], incl	±0.009 [0.23]	0.013 [0.33]
Over 1 to 1 1/8 [25.40 to 28.58], incl	±0.010 [0.25]	0.015 [0.38]
Over 1 1/8 to 1 1/4 [28.58 to 31.75], incl	±0.011 [0.28]	0.016 [0.41]
Over 1 1/4 to 1 3/8 [31.75 to 34.92], incl	±0.012 [0.30]	0.018 [0.46]
Over 1 3/8 to 1 1/2 [34.92 to 38.10], incl	±0.014 [0.36]	0.021 [0.53]
Over 1 1/2 to 2 [38.10 to 50.80], incl	±1/64 [0.40]	0.023 [0.58]
Over 2 to 2 1/2 [50.80 to 63.50], incl	+1/32, -0 [0.79]	0.023 [0.58]
Over 2 1/2 to 3 1/2 [63.50 to 88.90], incl	+3/64, -0 [1.19]	0.035 [0.89]
Over 3 1/2 to 4 1/2 [88.90 to 114.30], incl	+1/16, -0 [1.59]	0.046 [1.17]

<sup>A</sup> Out-of-round is the difference between the maximum and minimum diameters of the bar, measured at the same cross section.

<sup>B</sup> Out-of-square section is the difference in the two dimensions at the same cross section of a square bar, each dimension being the distance between opposite faces.

**TABLE 5 Permissible Variations in Size for Titanium Bars—Hot-Worked Hexagons and Octagons**

Specified Sizes Between Opposite Sides, in. [mm]	Size Variation, in. [mm]	Maximum Difference, 3 Measurements, in. [mm]
¼ to ½ [6.35 to 12.70], incl	±0.007 [0.18]	0.011 [0.28]
Over ½ to 1 [12.70 to 25.40], incl	±0.010 [0.25]	0.015 [0.38]
Over 1 to 1½ [25.40 to 38.10], incl	±0.021 [0.53]	0.025 [0.64]
Over 1½ to 2 [38.10 to 50.80], incl	±½ [0.79]	½ [0.79]
Over 2 to 2½ [50.80 to 63.50], incl	±¾ [1.19]	¾ [1.19]
Over 2½ to 3½ [63.50 to 88.90], incl	±⅞ [1.59]	⅞ [1.59]

**TABLE 6 Permissible Variations in Size for Titanium Bars—Hot-Worked Flats**

Specified Widths, in. [mm]	Thickness Variation from Specified Thickness, in. [mm]			Width Variation, in. [mm]
	⅙ to ½ in. [3.18 to 12.70 mm], incl	Over ½ to 1 in. [12.70 to 25.40 mm], incl	Over 1 to 2 in. [25.40 to 50.80 mm], incl	
To 1 [25.40], incl	±0.008 [0.20]	±0.010 [0.25]	...	+⅙, -⅙ [±0.40, -0.40]
Over 1 to 2 [25.40 to 50.80], incl	±0.012 [0.30]	±0.015 [0.38]	±½ [0.79]	+½, -½ [±0.79, -0.79]
Over 2 to 4 [50.80 to 101.60], incl	±0.015 [0.38]	±0.020 [0.51]	±½ [0.79]	+⅙, -⅙ [±1.59, -0.79]
Over 4 to 6 [101.60 to 152.40], incl	±0.015 [0.38]	±0.020 [0.51]	±½ [0.79]	+¾, -¾ [±2.38, -1.59]
Over 6 to 8 [152.40 to 203.20], incl	±0.016 [0.41]	±0.025 [0.64]	±½ [0.79]	+⅙, -⅙ [±3.18, -3.97]
Over 8 to 10 [203.20 to 254.0], incl	±0.021 [0.53]	±0.031 [0.79]	±½ [0.79]	+¾, -¾ [±3.97, -4.76]

**TABLE 7 Permissible Variations in Size for Titanium Bars—Cold-Finished Rounds**

Specified Size, in. [mm]	Size Variation, <sup>A</sup> in. [mm]
Over ½ to 1 [12.70 to 25.40], excl	±0.002 [0.05]
1 to 1½ [25.40 to 38.10], excl	±0.0025 [0.06]
1½ to 4 [38.10 to 101.60], incl	±0.003 [0.08]

<sup>A</sup> When it is necessary to heat treat or heat treat and pickle after cold finishing, because of special hardness or mechanical property requirements, tolerances are commonly double those shown in this table.

**TABLE 8 Permissible Variations in Size for Titanium Bars—Cold-Finished Hexagons, Octagons, and Squares**

Specified Size, in. [mm]	Size Variation, <sup>A</sup> in. [mm]
Over ½ to 1 [12.70 to 25.40], incl	+ 0, - 0.004 [-0.10]
Over 1 to 2 [25.40 to 50.80], incl	+ 0, - 0.006 [-0.16]
Over 2 to 3 [50.80 to 76.20], incl	+ 0, - 0.008 [-0.20]
Over 3 [76.20]	+ 0, - 0.010 [-0.25]

<sup>A</sup> When it is necessary to heat treat or heat treat and pickle after cold finishing, because of special hardness or mechanical property requirements, tolerances are commonly double those shown in this table.

sampling titanium for chemical analysis because of its great affinity for elements such as oxygen, nitrogen, and hydrogen. Therefore, in cutting samples for analysis, the operation should be carried out insofar as possible in a dust-free atmosphere. Chips should be collected from clean metal and tools should be clean and sharp. Samples for analysis should be stored in suitable containers.

9.2 At least two samples for chemical analysis shall be tested to determine chemical composition. Samples shall be taken from top and bottom ingot locations, or from product representative of the top and bottom of the ingot or from the opposite extremes of the product to be analyzed.

**10. Methods of Chemical Analysis**

10.1 The chemical analysis shall normally be conducted using the ASTM standard test methods referenced in 2.1. Other industry standard methods may be used where the ASTM test methods in 2.1 do not adequately cover the elements in the

material or by agreement between the producer and the purchaser. Alternate techniques are discussed in Guide E2626.

**11. Retests**

11.1 If the results of any chemical or mechanical property test lot are not in conformance with the requirements of this specification, the lot may be retested at the option of the manufacturer. The frequency of the retest will double the initial number of tests. If the results of the retest conform to the specification, then the retest values will become the test values for certification. Only original conforming test results or the conforming retest results shall be reported to the purchaser. If the results for the retest fail to conform to the specification, the material will be rejected in accordance with Section 14.

**12. Referee Test and Analysis**

12.1 In the event of disagreement between the manufacturer and the purchaser on the conformance of the material to the requirements of this specification, a mutually acceptable referee shall perform the tests in question using the ASTM standard test methods in 2.1. The referee’s testing shall be used in determining conformance of the material to this specification. Check analysis limits apply.

**13. Rounding-Off Procedure**

13.1 For purposes of determining conformance with the specifications contained herein, an observed or a calculated value shall be rounded off to the nearest “unit” in the last right-hand significant digit used in expressing the limiting value. This is in accordance with the round-off method of Practice E29.

**14. Rejection**

14.1 Material not conforming to this specification or to authorized modifications shall be subject to rejection. Unless otherwise specified, rejected material may be returned to the manufacturer at the manufacturer’s expense, unless the purchaser receives, within three weeks of notice of rejection, other instructions for disposition.

**TABLE 9 Permissible Variations in Size for Titanium Bars—Cold-Finished Flats**

Size Width or Thickness, in. [mm]	Width Variations <sup>A</sup> from Specified Thicknesses, in. [mm]		Thickness Variation, <sup>A</sup> in. [mm]
	¼ in. [6.35 mm] and under	Over ¼ in. [6.35 mm]	
Over ⅜ to 1 [9.54 to 25.40], incl	±0.004 [0.10]	±0.002 [0.05]	±0.002 [0.05]
Over 1 to 2 [25.40 to 50.80], incl	±0.006 [0.15]	±0.003 [0.08]	±0.003 [0.08]
Over 2 to 3 [50.80 to 76.20], incl	±0.008 [0.20]	±0.004 [0.10]	±0.004 [0.10]
Over 3 to 4½ [76.20 to 114.30], incl	±0.010 [0.25]	±0.005 [0.13]	±0.005 [0.13]

<sup>A</sup> When it is necessary to heat treat or heat treat and pickle after cold finishing, because of special hardness or mechanical property requirements, tolerances are commonly double those shown in this table.

**TABLE 10 Permissible Variations in Length for Titanium Bars—Hot Worked and Cold Finished**

Specified Sizes, all Shapes, in. [mm]	Length Variations, in. [mm]	
	To 12 ft [3.66 m], incl	Over 12 to 25 ft [3.66 to 7.62 m], incl
To 2 [50.80], incl	+½, -0 [+12.70]	+¾, -0 [+19.05]
Over 2 to 4 [50.80 to 101.60], incl	+¾, -0 [+19.05]	+1, -0 [+25.40]
Over 4 to 6 [101.60 to 152.40], incl	+1, -0 [+25.40]	+1¼, -0 [+31.75]
Over 6 to 9 [152.40 to 228.60], incl	+1¼, -0 [+31.75]	+1½, -0 [+38.10]
Over 9 to 12 [228.60 to 304.80], incl	+1½, -0 [+38.10]	+2, -0 [+50.80]
	Machine Cut After Machine Straightening	
To 3 [76.20], incl	+⅞, -0 [+3.18]	+⅝, -0 [+4.76]
Over 3 to 6 [76.20 to 152.40], incl	+⅝, -0 [+4.76]	+¾, -0 [+6.35]
Over 6 to 9 [152.40 to 228.60], incl	+¼, -0 [+6.35]	+⅝, -0 [+7.94]
Over 9 to 12 [228.60 to 304.80], incl	+½, -0 [+12.70]	+½, -0 [+12.70]

**TABLE 11 Camber for Hot-Worked and Cold-Finished Titanium Bars for Machining**

NOTE 1—Camber is the greatest deviation of a side from a straight line. Measurement is taken on the concave side of the bar with a straightedge. Unless otherwise specified, hot-worked and cold-finished bars for machining purposes are furnished machine straightened to the tolerances specified in this table.

	Tolerance
Hot worked	⅞ in. [3.18 mm] in any 5 ft [1524 mm], but may not exceed ⅞ × No. of ft in length
	5
Cold finished	⅞ in. [1.99 mm] in any 5 ft [1524 mm], but may not exceed ⅞ × No. of ft in length
	5

## 15. Certification

15.1 The manufacturer shall supply at least one copy of the report certifying that the material supplied has been manufactured, inspected, sampled, and tested in accordance with the requirements of this specification and that the results of chemical analysis, tensile, and other tests meet the requirements of this specification for the grade specified. The report shall include results of all chemical analysis, tensile tests, and all other tests required by the specification. The report shall include the manufacturing method (hot rolled, forged, extruded or cold worked).

## 16. Packaging and Package Marking

16.1 *Marking*—Unless otherwise specified, individual pieces or bundles shall have attached a metal tag stamped with

the purchase order number, the specification number, the nominal size and manufacturer's heat number, or shall be boxed and the box marked with the same information. In addition to the above identification, bars 1 in. [25.4 mm] and over in diameter or distance between parallel sides shall be stamped with the heat number within 2 in. [50.8 mm] of one end.

16.2 *Packaging*—Unless otherwise specified, material purchased under this specification may be packaged for shipment either by boxing, crating, single boarding, burlapping, or with no protection in accordance with the manufacturer's standard practice.

## 17. Keywords

17.1 bar; billet; titanium; titanium alloy

ASMENORMDOC.COM : Click to view the full PDF of ASME BPVC.II.B (ASME BPVC Section II part B) 2025

INTENTIONALLY LEFT BLANK

# SPECIFICATION FOR COPPER AND COPPER-ALLOY SEAMLESS CONDENSER AND HEAT EXCHANGER TUBES WITH INTEGRAL FINNS



**SB-359/SB-359M**



(25)

(Identical with ASTM Specification B359/B359M-23 except that certification and mill test reports have been made mandatory.)

*ASME SB-359/SB-359M replaces paras. 5.2.2, 5.2.4, 5.2.5, 22.1, 22.2, 23.1 of ASTM B359/B359M with the following:*

5.2.2 DELETED

5.2.4 DELETED

5.2.5 DELETED

22.1 A manufacturer's certificate of compliance shall be furnished to the purchaser stating that samples representing each lot have been tested and inspected in accordance with this specification and the requirements have been met.

22.2 DELETED

23.1 The manufacturer or supplier shall furnish to the purchaser a manufacturer's test report showing the results of the required tests.



Designation: B359/B359M – 23

# Standard Specification for Copper and Copper-Alloy Seamless Condenser and Heat Exchanger Tubes With Integral Fins<sup>1</sup>

This standard is issued under the fixed designation B359/B359M; the number immediately following the designation indicates the year of original adoption or, in the case of revision, the year of last revision. A number in parentheses indicates the year of last reapproval. A superscript epsilon (ε) indicates an editorial change since the last revision or reapproval.

## 1. Scope\*

1.1 This specification<sup>2</sup> covers the requirements for seamless copper and copper alloy tubing on which the external or internal surface, or both, has been modified by a cold-forming process to produce an integral enhanced surface for improved heat transfer.

1.2 The tubes are typically used in surface condensers, evaporators, and heat exchangers.

1.3 The product shall be produced of the following coppers or copper alloys, as specified in the ordering information.

Copper or Copper Alloy UNS No.	Type of Metal
C10100	Oxygen-free electronic
C10200	Oxygen-free without residual deoxidants
C10300	Oxygen-free, extra low phosphorus
C10800	Oxygen-free, low phosphorus
C12000	DLP Phosphorized, low residual phosphorus (See Note 1)
C12200	DHP, Phosphorized, high residual phosphorus (See Note 1)
C14200	DPA Phosphorized arsenical (See Note 1)
C15630	Nickel Phosphorus
C19200	Phosphorized, 1 % iron
C23000	Red Brass
C44300	Admiralty Metal Types B,
C44400	C, and
C44550	D
C60800	Aluminum Bronze
C68700	Aluminum Brass Type B
C70400	95-5 Copper-Nickel
C70600	90-10 Copper-Nickel
C70620	90-10 Copper-Nickel (Modified for Welding)

Copper or Copper Alloy UNS No.	Type of Metal
C71000	80-20 Copper-Nickel Type A
C71500	70-30 Copper-Nickel
C71520	70-30 Copper-Nickel (Modified for Welding)
C72200	Copper-Nickel

NOTE 1—Designations listed in Classification B224.

1.4 *Units*—The values stated in either in-pound units or SI units are to be regarded separately as the standard. Within the text, the SI units are shown in brackets. The values stated in each system are not exact equivalents; therefore, each system shall be used independently of the other. Combining values from the two systems could result in nonconformance with the specification.

1.5 Product produced in accordance with the Supplementary Requirements section for military applications shall be produced only to the inch-pound system of this specification.

1.6 The following safety hazard caveat pertains only to the test methods described in this specification. *This standard does not purport to address all of the safety concerns, if any, associated with its use. It is the responsibility of the user of this standard to establish appropriate safety, health, and environmental practices and determine the applicability of regulatory limitations prior to use.* Some specific hazards statements are given in Sections 1, 12 and 18.

1.7 (**Warning**—Mercury has been designated by many regulatory agencies as a hazardous substance that can cause serious medical issues. Mercury, or its vapor, has been demonstrated to be hazardous to health and corrosive to materials. Use caution when handling mercury and mercury-containing products. See the applicable product Safety Data Sheet (SDS) for additional information. The potential exists that selling mercury or mercury-containing products, or both, is prohibited by local or national law. Users must determine legality of sales in their location.)

<sup>1</sup> This specification is under the jurisdiction of ASTM Committee B05 on Copper and Copper Alloys and is the direct responsibility of Subcommittee B05.04 on Pipe and Tube.

Current edition approved Oct. 1, 2023. Published October 2023. Originally approved in 1960. Last previous edition approved in 2018 as B359/B359M – 18. DOI: 10.1520/B0359\_B0359M-23.

<sup>2</sup> For ASME Boiler and Pressure Vessel Code applications, see related Specification SB-359 in Section II of that Code.

1.8 This international standard was developed in accordance with internationally recognized principles on standardization established in the *Decision on Principles for the Development of International Standards, Guides and Recommendations issued by the World Trade Organization Technical Barriers to Trade (TBT) Committee*.

## 2. Referenced Documents

### 2.1 ASTM Standards:<sup>3</sup>

- B153 Test Method for Expansion (Pin Test) of Copper and Copper-Alloy Pipe and Tubing
- B154 Test Method for Mercurous Nitrate Test for Copper Alloys
- B170 Specification for Oxygen-Free Electrolytic Copper—Refinery Shapes
- B224 Classification of Coppers
- B601 Classification for Temper Designations for Copper and Copper Alloys—Wrought and Cast
- B846 Terminology for Copper and Copper Alloys
- B858 Test Method for Ammonia Vapor Test for Determining Susceptibility to Stress Corrosion Cracking in Copper Alloys
- B900 Practice for Packaging of Copper and Copper Alloy Mill Products for U.S. Government Agencies
- B968/B968M Test Method for Flattening of Copper and Copper-Alloy Pipe and Tube
- D4727/D4727M Specification for Corrugated and Solid Fiberboard Sheet Stock (Container Grade) and Cut Shapes
- E3 Guide for Preparation of Metallographic Specimens
- E8/E8M Test Methods for Tension Testing of Metallic Materials
- E29 Practice for Using Significant Digits in Test Data to Determine Conformance with Specifications
- E53 Test Method for Determination of Copper in Unalloyed Copper by Gravimetry (Withdrawn 2022)<sup>4</sup>
- E62 Test Methods for Chemical Analysis of Copper and Copper Alloys (Photometric Methods) (Withdrawn 2010)<sup>4</sup>
- E112 Test Methods for Determining Average Grain Size
- E118 Test Methods for Chemical Analysis of Copper-Chromium Alloys (Withdrawn 2010)<sup>4</sup>
- E243 Practice for Electromagnetic (Eddy Current) Examination of Copper and Copper-Alloy Tubes
- E255 Practice for Sampling Copper and Copper Alloys for the Determination of Chemical Composition
- E478 Test Methods for Chemical Analysis of Copper Alloys
- E2575 Test Method for Determination of Oxygen in Copper and Copper Alloys by Inert Gas Fusion

### 2.2 ASME Standard:<sup>5</sup>

ASME Boiler and Pressure Vessel Code

<sup>3</sup> For referenced ASTM standards, visit the ASTM website, [www.astm.org](http://www.astm.org), or contact ASTM Customer Service at [service@astm.org](mailto:service@astm.org). For *Annual Book of ASTM Standards* volume information, refer to the standard's Document Summary page on the ASTM website.

<sup>4</sup> The last approved version of this historical standard is referenced on [www.astm.org](http://www.astm.org).

<sup>5</sup> Available from American Society of Mechanical Engineers (ASME), ASME International Headquarters, Two Park Ave., New York, NY 10016-5990, <http://www.asme.org>.

## 3. General Requirements

3.1 Product described by this specification shall typically be furnished with unenhanced ends, but may be furnished with enhanced ends or stripped ends from which the O.D. enhancement has been removed by machining.

3.1.1 The enhanced sections of the tube in the as-fabricated temper are in the cold-worked condition produced by the enhancing operation.

3.1.2 The unenhanced sections of the tube shall be in the annealed or light drawn temper, and shall be suitable for rolling-in operations.

## 4. Terminology

4.1 For the definitions of terms related to copper and copper alloys, refer to Terminology B846.

### 4.2 Definitions of Terms Specific to This Standard:

4.2.1 *tube condenser, n*—see *tube, heat exchanger* in Terminology B846.

## 5. Ordering Information

5.1 Include the following information when placing orders under this specification:

5.1.1 ASTM designation and year of issue,

5.1.2 Copper or Copper Alloy UNS No. designation (see 1.3 and Section 7),

5.1.3 Temper (see Section 8),

5.1.4 Dimensions: diameter, wall thickness, length and location of unenhanced surfaces and total tube length. Configuration of enhanced surfaces shall be as agreed upon between the manufacturer and the purchaser. (See Figs. 1 and 2).

5.1.5 Whether the product is to be subsequently welded for UNS Alloy C72200, UNS Alloys C70620 and C71520 are welding grades of C70600 and C71500,

5.1.6 Quantity, and

5.1.7 If product is for the U.S. government.

5.2 The following options are available and shall be specified at the time of placing the order, when required:

5.2.1 When heat identification or traceability is required,

5.2.2 When tubes are for Boiler and Pressure Vessel code application, which should then be ordered according to ASME SB 359,

5.2.3 Flattening test (see 11.2),

5.2.4 Certification (see Section 22), when required,

5.2.5 Mill test report (see Section 23), when required, and

5.2.6 Stress relief annealing (see 9.4), when required.

5.3 In addition, when material is purchased for agencies of the U.S. government, it shall conform to the requirements specified in the Supplementary Requirements section, when specified in the contract or purchase order.

## 6. Materials and Manufacture

### 6.1 Materials:

6.1.1 The material of manufacture shall be of such quality and purity that the finished product shall have the properties and characteristics prescribed in this specification for the applicable alloy and temper.

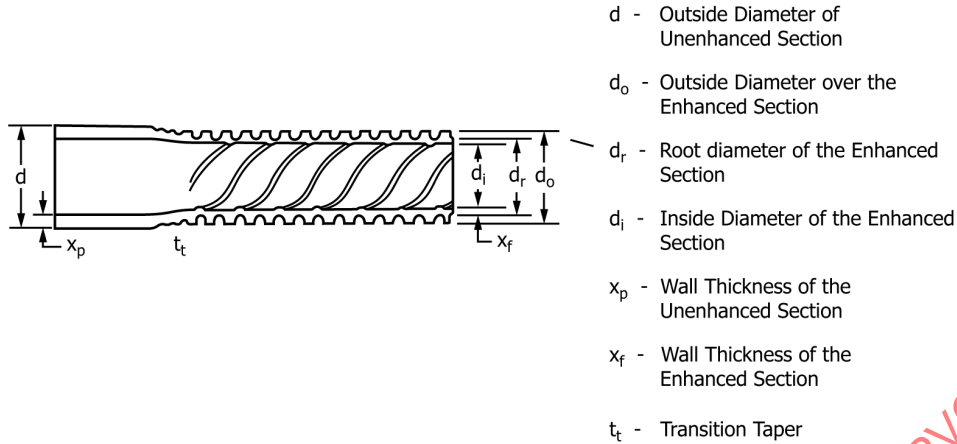

NOTE 1—The outside diameter over the enhanced section will not normally exceed the outside diameter of the unenhanced section.

FIG. 1 Enhanced Tube Nomenclature

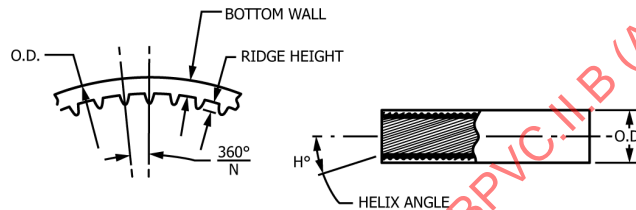

FIG. 2 Inside Enhanced Tube Nomenclature (Internal Groove Tube)

6.2 Manufacture:

6.2.1 The seamless copper and copper alloy tubing shall have the internal or external surface, or both, modified by a cold forming process to produce an integral enhanced surface for improved heat transfer.

6.2.2 The cut ends of the tubes shall be deburred.

6.2.3 Due to the discontinuous nature of the processing of castings into wrought products, it is not practical to identify specific casting analysis with a specific quantity of finished material.

6.2.4 When heat identification is required, the purchaser shall specify the details desired in the purchase order or contract.

7. Chemical Composition

7.1 The tubes shall conform to the chemical requirements specified in Table 1 for copper or copper alloy specified in the ordering information.

7.2 These specification limits do not preclude the presence of unnamed elements. By agreement between the manufacturer, or supplier and purchaser, analysis may be required and limits established for elements not specified.

7.2.1 For alloys in which copper is specified as the remainder, copper may be taken as the difference between the sum of the results for all specified elements and 100 % for the particular alloy.

7.2.2 For alloys in which zinc is specified as the remainder, either copper or zinc may be taken as the difference between the sum of the results of specified elements analyzed and 100 %.

8. Temper

8.1 Tempers, as defined in Classification B601 and this document, are as follows:

8.1.1 The tube, after enhancing, shall be supplied, as specified, in the annealed (O61), heavy anneal (O62), or as-fabricated temper.

8.1.1.1 The enhanced sections of tubes in the as-fabricated temper are in the cold-worked condition produced by the fabricating operation.

8.1.1.2 The unenhanced sections of tubes in the as-fabricated temper are either in the temper of the tube prior to enhancing (annealed (O61), heavy anneal (O62), light drawn (H55), or hard drawn (H80)) or when cold working of the unenhanced portions is performed as a part of the enhancing operations they shall be in the light drawn (H55) temper. In either case, the unenhanced surfaces shall be suitable for rolling-in operations.

8.1.1.3 Copper Alloy UNS Nos. C23000, C44300, C44400, C44500, C60800, and C68700, furnished in the as-fabricated temper, shall be stress-relief annealed after enhancing and be capable of meeting the requirements of the stress-corrosion

TABLE 1 Chemical Composition

Copper or Copper Alloy UNS No.	Composition, %												
	Copper	Tin	Aluminum	Nickel, incl Cobalt	Lead, max	Iron	Zinc	Manganese	Arsenic	Antimony	Phosphorus	Chromium	Other Named Elements
C10100	99.99 min <sup>A,B</sup>	0.0002 max	...	0.0010 max	0.0005	0.0010 max	0.0001 max	0.00005 max	0.0005 max	0.0004 max	0.0003 max	...	Te 0.0002
C10200	99.95 min <sup>C,D,E</sup>	...	...	...	...	...	...	...	...	...	...	...	...
C10300	99.95 min <sup>C,F,G</sup>	...	...	...	...	...	...	...	...	...	0.001–0.005	...	...
C10800	99.95 min <sup>C,F,G</sup>	...	...	...	...	...	...	...	...	...	0.005–0.012	...	...
C12000	99.90 min <sup>C</sup>	...	...	...	...	...	...	...	...	...	0.004–0.012	...	...
C12200	99.9 min <sup>C</sup>	...	...	...	...	...	...	...	...	...	0.015–0.040	...	...
C14200	99.4 min <sup>C</sup>	...	...	...	...	...	...	...	0.15–0.50	...	0.015–0.040	...	...
C15630	remainder <sup>C,H</sup>	...	...	0.60–0.90 <sup>I</sup>	...	...	...	...	...	...	0.015–0.040	...	...
C19200	98.5 min <sup>J</sup>	...	...	...	...	0.8–1.2	0.20 max	...	...	...	0.01–0.04	...	...
C23000	84.0–86.0 <sup>J</sup>	...	...	...	0.05	0.05 max	remainder	...	...	...	...	...	...
C44300	70.0–73.0 <sup>K</sup>	0.9–1.2	...	...	0.07	0.06 max	remainder	...	0.02–0.06	...	...	...	...
C44400	70.0–73.0 <sup>K</sup>	0.9–1.2	...	...	0.07	0.06 max	remainder	...	...	0.02–0.10	...	...	...
C44500	70.0–73.0 <sup>K</sup>	0.9–1.2	...	...	0.07	0.06 max	remainder	...	...	...	0.02–0.10	...	...
C60800	remainder <sup>C,H</sup>	...	5.0–6.5	...	0.10	0.10 max	...	...	0.02–0.35	...	...	...	...
C68700	76.0–79.0 <sup>C,H</sup>	...	1.8–2.5	...	0.07	0.06 max	remainder	...	0.02–0.06	...	...	...	...
C70400	remainder <sup>C,H</sup>	...	...	4.8–6.2	0.05	1.3–1.7	1.0 max	0.30–0.8	...	...	...	...	...
C70600	remainder <sup>C,H</sup>	...	...	9.0–11.0	0.05	1.0–1.8	1.0 max	1.0 max	...	...	...	...	...
C70620	86.5 min <sup>C,H</sup>	...	...	9.0–11.0	0.02	1.0–1.8	0.5 max	1.0 max	...	...	0.02 max	...	0.05 C max 0.02 S max
C71000	remainder <sup>C,H,L</sup>	...	...	19.0–23.0	0.05	1.0 max	1.0 max	1.0 max	...	...	...	...	...
C71500	remainder <sup>C,H</sup>	...	...	29.0–33.0	0.05	0.40–1.0	1.0 max	1.0 max	...	...	...	...	...
C71520	65.0 min <sup>G,H</sup>	...	...	29.0–33.0	0.02	0.40–1.0	0.50 max	1.0 max	...	...	0.02 max	...	0.05 C max 0.02 S max
C72200	remainder <sup>C,J,L</sup>	...	...	15.0–18.0	0.05	0.50–1.0	1.0 max	1.0 max	...	...	...	0.30–0.70	0.03 Si 0.03 Ti

<sup>A</sup> This value is exclusive of silver and shall be determined by difference of "impurity total" from 100 %. "Impurity total" is defined as the sum of sulfur, silver, lead, tin, bismuth, arsenic, antimony, iron, nickel, zinc, phosphorus, selenium, tellurium, manganese, cadmium, and oxygen present in the sample.

<sup>B</sup> Other impurity maximums for C10100 shall be: bismuth and cadmium 0.0001 each, oxygen 0.0005, selenium 0.0003, silver 0.0025, and sulfur 0.0015.

<sup>C</sup> Copper (including silver).

<sup>D</sup> Oxygen in C10200 shall be 0.0010 max.

<sup>E</sup> Cu is determined by the difference in the impurity total and 100 %.

<sup>F</sup> Copper plus sum of named elements shall be 99.95 % min.

<sup>G</sup> Includes P.

<sup>H</sup> Cu + Sum of Named Elements, 99.5 % min.

<sup>I</sup> Not including Co.

<sup>J</sup> Cu + Sum of Named Elements, 99.8 % min.

<sup>K</sup> Cu + Sum of Named Elements, 99.6 % min.

<sup>L</sup> When the product is for subsequent welding applications, and so specified in the contract or purchase order, zinc shall be 0.50 % max, lead 0.02 % max, phosphorus 0.02 % max, sulfur 0.02 % max, and carbon 0.05 % max.

susceptibility requirement in Section 12. Stress-relief annealing of alloys not listed in this paragraph is not required unless specified by customer.

## 9. Grain Size of Annealed Temper

9.1 Samples of annealed-temper (O61, O62) tubes selected for test shall be subjected to microscopical examination at a magnification of 75 diameters and shall show uniform and complete recrystallization.

9.2 Average grain size shall be within limits agreed upon between the manufacturer and purchaser.

9.3 The requirements of this section do not apply to product shipped in the as-fabricated temper.

9.4 Some annealed tubes, when subjected to aggressive environments, may be subject to stress-corrosion cracking failure because of the residual tensile stresses developed in straightening. For such applications, it is recommended that

tubes of Copper Alloy UNS Nos. C23000, C44300, C44400, C44500, C60800, and C68700 be subjected to a stress relieving thermal treatment subsequent to straightening. When required, this must be specified on the purchase order or contract. Tolerance for roundness and length, and the condition for straightness, for tube so ordered, shall be to the requirements agreed upon between the manufacturer and purchaser.

## 10. Mechanical Property Requirements

### 10.1 Tensile Property Requirements:

10.1.1 Prior to the enhancing operation, the tube shall conform to the requirements for tensile properties prescribed in Table 2.

10.1.2 Alternatively, for those enhancing operations that include cold working of the unenhanced portions of the tube integral to the process, the unenhanced portions shall conform to the H55 as prescribed in Table 2 for the UNS alloys identified.

TABLE 2 Tensile Requirements

Copper or Copper Alloy UNS No.	Temper Designation		Tensile Strength, min	Yield Strength, <sup>A</sup> min
	Standard	Former	ksi <sup>B</sup> [MPa]	ksi <sup>B</sup> [MPa]
C10100, C10200, C10300, C10800, C12000, C12200, C14200	O61	annealed	30 [205]	9 [62] <sup>C</sup>
C10100, C10200, C10300, C10800, C12000, C12200, C14200	O62	heavy anneal	30 [205]	6.5 [45] <sup>C</sup>
C10100, C10200, C10300, C10800, C12000, C12200, C14200	H55	light-drawn	36 [250]	30 [205]
C10100, C10200, C10300, C10800, C12000, C12200, C14200	H80	hard-drawn	45 [310]	40 [275]
C15630	O61	annealed	30 [205]	8 [55]
C19200	O61	annealed	38 [260]	12 [85]
C23000	O61	annealed	40 [275]	12 [85]
C44300, C44400, C44500	O61	annealed	45 [310]	15 [105]
C60800	O61	annealed	50 [345]	19 [130]
C68700	O61	annealed	50 [345]	18 [125]
C70400	O61	annealed	38 [260]	12 [85]
C70600	O61	annealed	40 [275]	15 [105]
C70620	O61	annealed	40 [275]	15 [105]
C71000	O61	annealed	45 [310]	16 [110]
C71500	O61	annealed	52 [360]	18 [125]
C71520	O61	annealed	52 [360]	18 [125]
C72200	O61	annealed	45 [310]	16 [110]

<sup>A</sup> At 0.5 % extension under load.

<sup>B</sup> ksi = 1000 psi.

<sup>C</sup> Light straightening operation is permitted.

## 11. Performance Requirements

11.1 *Expansion Test*—The unenhanced sections of all tubes selected for test shall conform to the requirements prescribed in Table 3 when tested in accordance with Test Method B153. The expanded tube shall show no cracking or rupture visible to the unaided eye.

### 11.2 Flattening Test:

11.2.1 When specified in the contract or purchase order, the flattening test described in the Test Method B968/B968M shall be performed.

11.2.1.1 During inspection, the flattened areas of the test-specimen shall be free of defects, but blemishes of a nature that do not interfere with the intended application are acceptable.

## 12. Other Requirements

### 12.1 Mercurous Nitrate Test or Ammonia Vapor Test:

12.1.1 The mercurous nitrate or ammonia vapor test is required only for Copper Alloys UNS Nos. C23000, C44300, C44400, C44500, C60800, and C68700. (**Warning**—Mercury is a definite health hazard and therefore equipment for the detection and removal of mercury vapor produced in volatilization is recommended. The use of rubber gloves in testing is advisable.)

12.1.2 The test specimens, cut 6 in. [150 mm] in length from the enhanced section shall withstand, without cracking, an immersion in the standard mercurous nitrate solution in Test

TABLE 3 Expansion Requirements

Temper Designation		Copper or Copper Alloy UNS No.	Expansion of Tube Outside Diameter in Percent of Original Outside Diameter
Standard	Former		
O61	annealed	C10100, C10200, C10300, C10800, C12000, C12200, C14200	30
O62	heavy anneal	C10100, C10200, C10300, C10800, C12000, C12200, C14200	30
H55	light-drawn	C10100, C10200, C10300, C10800, C12000, C12200, C14200	20
H80	hard-drawn	C10100, C10200, C10300, C10800, C12000, C12200, C14200	20
O61	annealed	C15630	40
O61	annealed	C19200	30
O61	annealed	C23000	20
O61	annealed	C44300, C44400, C44500	20
O61	annealed	C60800	20
O61	annealed	C68700	20
O61	annealed	C70400	30
O61	annealed	C70600, C70620	30
O61	annealed	C71000	30
O61	annealed	C71500, C71520	30
O61	annealed	C72200	30

Method B154 or immersion in the ammonia vapor solution as defined in Test Method B858.

12.1.3 Unless otherwise agreed upon between the manufacturer, or supplier, and the purchaser, the manufacturer shall have the option of using either the mercurous nitrate test or the ammonia vapor test. If agreement cannot be reached, the mercurous nitrate test standard shall be utilized.

12.1.4 If the ammonia vapor test is selected, the appropriate risk level pH value for the test solution shall be agreed upon by the manufacturer and purchaser, or alternately, if the purchaser defers to the manufacturer's expertise for the selection of the test pH value, the minimum value selected shall be 9.8.

#### 12.2 Non-Destructive Testing:

12.2.1 Each tube shall be subjected to a non-destructive test. Tubes shall normally be tested in the as-fabricated temper but, at the option of the manufacturer, may be tested in the annealed temper. Unless otherwise specified, the manufacturer shall have the option of testing the tubes by one of the following test methods:

##### 12.2.1.1 Non-Destructive Examination for Defects:

(1) The tubes shall be passed through an eddy-current testing unit adjusted in accordance with the requirements of 18.3.3 to provide information on the suitability of the tube for the intended application.

(2) Tubes causing irrelevant signals because of moisture, soil, and like effects may be reconditioned and retested. Such tubes shall be considered to conform, should they not cause output signals beyond the acceptable limits.

(3) Tubes causing irrelevant signals because of visible and identifiable handling marks may be retested by the hydrostatic test prescribed in 12.2.1.2 or the pneumatic test prescribed in 12.2.1.3.

(4) Unless otherwise agreed, tubes meeting the requirements of either test shall be considered to conform if the tube dimensions are within the prescribed limits.

12.2.1.2 *Hydrostatic Test*—Each tube, without showing evidence of leakage, shall withstand an internal hydrostatic pressure sufficient to subject the material in the unenhanced region of the tube to a fiber stress of 7000 psi [48 MPa], as determined by the following equation for thin hollow cylinders under tension:

$$P = \frac{2St}{(D - 0.8t)} \quad (1)$$

where:

- $P$  = hydrostatic pressure, psig, [MPa],  
 $t$  = thickness of tube wall, in., [mm],  
 $D$  = outside diameter of tube, in., [mm], and  
 $S$  = allowable fiber stress of the material, psi [MPa].

The tube need not be tested at a hydrostatic pressure over 1000 psi [6.9 MPa] unless so specified.

12.2.1.3 *Pneumatic Test*—Each tube, after enhancing, shall withstand a minimum internal air pressure of 250 psig [1.7 MPa] for 5 s and any evidence of leakage shall be cause for rejection. The test method used shall permit easy visual detection of any leakage, such as having the tube under water, or by the pressure differential method.

### 13. Dimensions, Mass, and Permissible Variations

#### 13.1 Tube Diameter:

13.1.1 The outside diameter of the unenhanced sections shall not vary by more than the amount shown in Table 4 for the appropriate dimensional system, as measured by “go” and “no go” ring gages. The diameter over the enhanced sections shall not exceed the diameter of the plain sections involved, as determined by a “go” ring gage, unless otherwise specified.

13.2 *Wall Thickness*—No tube shall be less than the minimum thickness specified in the plain sections or in the enhanced sections.

#### 13.3 Length:

13.3.1 The length of the tubes shall not be less than that specified when measured at a temperature of 68 °F [20 °C], but may exceed the specified value by the amounts shown in Table 5, for the appropriate dimensional system.

13.3.2 The length of the unenhanced end(s), as measured from the tube end to the first fin disk impression, shall not be less than that specified, but may exceed the specified value by ½ in. [13 mm].

13.4 *Squareness of Cut*—The departure from squareness of the end of any tube shall not exceed the tolerance stated in Table 6, for the appropriate dimensional system.

### 14. Workmanship, Finish, and Appearance

14.1 Roundness, straightness, uniformity of wall thickness, and condition of inner and outer surfaces of the tube shall be such as to make it suitable for the intended application. Unless otherwise specified on the purchase order, the cut ends of the tubes shall be deburred by use of a rotating wire wheel or other suitable tool.

14.2 Annealed-temper (O61, O62) or stress-relieved tubes shall be clean and smooth, but may have a superficial, dull iridescent film on both the inside and outside surface. Tubes in the as-fabricated temper may have a superficial film of finning lubricant on the surfaces.

### 15. Sampling

15.1 The lot size, portion size, and selection of sample pieces shall be as follows:

15.1.1 *Lot Size*—600 tubes or 10 000 lb [4550 kg] or fraction of either, whichever constitutes the greater weight.

15.1.2 *Portion Size*—Sections from two individual lengths of finished product.

15.1.2.1 Samples taken for purposes of test shall be selected in a manner that will correctly represent the material furnished and avoid needless destruction of finished material when samples representative of the material are available from other sources.

TABLE 4 Diameter Tolerances

Specified Diameter, in. [mm]	Tolerance, in. [mm]
0.500 [12.0] and under	±0.002 [0.050]
Over 0.500–0.740 [12.0–18.0], incl	±0.0025 [0.063]
Over 0.740–1.000 [18.0–25.0], incl	±0.003 [0.076]
Over 1.000	As agreed upon

TABLE 5 Length Tolerances

Specified Length, ft [mm]	Tolerance, all Plus, in. [mm]
Up to 20 [6000], incl	1/8 [3.2]
Over 20–30 [6000-10 000], incl	5/32 [4.0]
Over 30–60 [10 000-18 000], incl	1/4 [6.4]

TABLE 6 Squareness of Cut

Specified Outside Diameter, in. [mm]	Tolerance, in. [mm]
Up to 5/8 [16.0], incl	0.010 [0.25]
Over 5/8 [16.0]	0.016 in./in. [0.016 mm/mm] of diameter

### 15.2 Chemical Composition:

15.2.1 Samples for determining composition shall be taken in accordance with Practice E255. The minimum weight of the composite sample shall be 150 g.

15.2.2 Instead of sampling in accordance with Practice E255, the manufacturer shall have the option of sampling at the time castings are poured or sampling the semi-finished product. When samples are taken during the course of manufacture, sampling of the finished product is not required and the minimum number of samples to be taken shall be as follows:

15.2.2.1 When samples are taken at the time castings are poured, one sample shall be taken for each group of castings poured simultaneously from the same source of molten metal.

15.2.2.2 When samples are taken from the semi-finished product, one sample shall be taken to represent each 10 000 lb [4550 kg] or fraction thereof, except that not more than one sample shall be required per piece.

### 16. Number of Tests and Retest

#### 16.1 Tests:

16.1.1 *Chemical Analysis*—Chemical composition shall be determined as the arithmetic mean of at least two replicate determinations of each specified element.

16.1.2 *Grain Size*—For annealed temper only, two tubes shall be selected from each lot and each tube shall be tested to verify the requirements of Section 9.

#### 16.1.3 Tensile Property Requirements:

16.1.3.1 Two tubes shall be selected from each lot prior to enhancement for those enhancing operations that provide no cold working to the unenhanced portions of the tube.

16.1.3.2 For product that is cold worked in the unenhanced portions of the tube integral to the manufacturing process, two samples shall be taken from the unenhanced portions of two tubes from each lot of finished product.

16.1.3.3 Each tube sampled, by the designated method above, shall be tested to verify the requirements of Section 10.

#### 16.1.4 Expansion Test:

16.1.4.1 Two tubes shall be selected from each lot prior to enhancement for those enhancing operations that provide no cold working to the unenhanced portions of the tube.

16.1.4.2 For product that is cold worked in the unenhanced portions of the tube integral to the manufacturing process, two samples shall be taken from the unenhanced portions of two tubes from each lot of finished product.

16.1.4.3 Each tube sampled, by the designated method above, shall be tested to verify the requirements in 11.1.

16.1.5 *Flattening Test*—One tube shall be selected from each lot prior to enhancement and each tube shall be tested to verify the requirements of 11.2.

16.1.6 *Mercurous Nitrate Test or Ammonia Vapor Test*—Two tubes shall be selected from each lot after enhancement and stress relief anneal. Each tube shall be tested to verify the requirements of 12.1.2.

#### 16.2 Retest:

16.2.1 One retest shall be permitted for each requirement under the same conditions stated for the original test.

16.2.2 Should the result of a retest fail to conform with the requirements of the product specification, the material shall be rejected.

### 17. Specimen Preparation

#### 17.1 Chemical Analysis:

17.1.1 Sample preparation shall be in accordance with Practice E255.

17.1.2 Preparation of the analytical test specimen shall be the responsibility of the reporting laboratory.

#### 17.2 Grain Size:

17.2.1 Specimens for the microscopic examination shall be prepared in accordance with Guide E3.

17.2.2 The surface of the specimen shall approximate a radial longitudinal section of the tube.

#### 17.3 Expansion Test Specimen:

17.3.1 Test Specimens shall conform to the requirements of the Specimen Preparation Section of Test Method B153.

#### 17.4 Flattening Test (B968/B968M):

17.4.1 A test specimen shall be cut to a length that will allow the tube to be flattened at three (3) places along the length, with each flattened area to be at least 2 in. [50 mm] in length. When the temper is other than annealed, the sample may be annealed prior to testing.

#### 17.5 Mercurous Nitrate or Ammonia Vapor Test:

17.5.1 Specimens for the mercurous nitrate test shall be 6 in. [150 mm] in length and shall be taken from the enhanced and unenhanced portion of each sample.

#### 17.6 Tension Tests:

17.6.1 Tension test specimens shall be of the full section of the tube and shall conform to the requirements of the Test Specimen section of Test Methods E8/E8M, unless the limitations of the testing machine precludes the use of such specimen, in which case test specimens conforming to specimen No. 1 of Fig. 13 in Test Methods E8/E8M shall be used.

17.6.2 Whenever test results are obtained from full-sized and machined specimens and they differ, the results from the full-sized specimen shall prevail for determining conformance to the specification.

17.6.3 Although a considerable range of testing speed is permissible, the range of stressing to the yield strength should not exceed 100 ksi/min [690 MPa/min]. Above the yield strength the movement per minute of the testing machine head

under load shall not exceed 0.5 in./in. [0.5 mm/mm] of the gage length, or distance between grips for a full section specimen.

## 18. Test Methods

### 18.1 Chemical Composition:

18.1.1 The methods used for routine determination of specification compliance shall be at the discretion of the reporting laboratory.

18.1.2 In case of disagreement concerning chemical composition of Copper Alloy UNS No. C10100, refer to the Test Method Section of Specification B170.

18.2 Chemical composition for all other alloys, in case of disagreement, shall be determined as follows:

18.2.1 Test methods for the determination of elements resulting from contractual or purchase order agreements shall be as agreed upon between the manufacturer or supplier and purchaser. (Refer to Table 1, Footnote D).

Element	Range	Test Method
Copper	99.75 to 99.99	E53, Electrolytic
Copper	70.0 to 99.75	E478, Electrolytic
Tin	0.9 to 1.2	E478, Photometric
Aluminum	1.8 to 6.5	E478
Nickel, inc. Cobalt	4.8 to 33.0	E478, Gravimetric
Lead	0.05 to 0.10	E478, Atomic Absorption
Iron	0.04 to 1.8	E478
Zinc	14.0 to 30.0	E478, Titrimetric
Zinc	to 1.0	E478, Atomic Absorption
Manganese	to 1.0	E62
Arsenic	0.02 to 0.5	E62
Antimony	0.02 to 0.1	E62
Phosphorus	0.001 to 0.04	E62
Chromium	0.30 to 0.70	E118
Oxygen	0.0005 to 0.0010	E2575

18.3 The material shall conform to the physical requirements and mechanical properties enumerated in this specification when tested in accordance with the following methods:

Test	ASTM Designation
Grain Size	E112
Expansion (pin test)	B153
Mercurous Nitrate	B154
Tension	E8/E8M
Eddy-Current Test	E243
Ammonia Vapor Test	B858
Flattening Test	B968/B968M

18.3.1 *Grain Size*—The intercept method shall be used to determine grain size in case of dispute.

18.3.2 *Test Method B154*—(Warning—This test method involves the use of a mercury compound that is classified as a health hazard in use and disposal.)

18.3.3 *Eddy-Current*—Testing shall follow the procedures of Practice E243, except that the sensitivity settings of the test equipment shall be adjusted using the hole sizes specified in Table 7 of this specification. The manufacturer may use a smaller drilled hole standard if desired. The holes for sensitivity adjustment shall be drilled radially through an unenhanced portion of the standard tube or through a length of prime

TABLE 7 Diameter of Drilled Holes

Nominal Diameter Over Enhanced or Unenhanced Section, in. [mm]	Diameter of Drilled Holes, in. [mm]
¼–⅝ [6.0–16.0], incl	0.042 [1.07]—No. 58 drill
Over ⅝–1 [16.0–25.0], incl	0.046 [1.17]—No. 56 drill

surface tube of the same size, temper, and composition. By mutual agreement between the manufacturer or supplier and purchaser, discontinuities of other contours may be used on the calibration standard.

18.3.3.1 Tubes that do not actuate the signaling device on the eddy current tester shall be considered as conforming to the requirements of this test.

## 19. Significance of Numerical Limits

19.1 For purposes of determining compliance with the specified limits of the properties listed in the following table, an observed or calculated value shall be rounded as indicated in accordance with the rounding method of Practice E29.

Property	Rounded Unit for Observed or Calculated Value
Chemical Composition	Nearest unit in the last right hand place of figures
Tensile and Yield Strength	Nearest ksi [Nearest 5 MPa]
Grain Size:	
Up to 0.055 mm, incl.,	Nearest multiple of 0.005 mm
Over 0.055 mm	to the nearest 0.010 mm
Expansion	Nearest 1 %

## 20. Inspection

20.1 The manufacturer shall inspect and make the necessary tests to verify that the tubes furnished conform to the requirements of this specification.

20.2 Should the purchaser additionally elect to perform his own inspection, the manufacturer shall, without charge, afford the inspector all reasonable facilities to determine that the tubes being furnished conform to the requirements of this specification.

20.2.1 Except for chemical analysis, all tests and inspections shall be made at the place of manufacture prior to shipment, unless otherwise specified, and shall be so conducted as not to interfere with the operation of the facility.

20.3 When automated finishing and inspection equipment is available at a facility, purchaser and manufacturer may, by mutual agreement, accomplish the final inspection simultaneously.

## 21. Rejection and Rehearing

### 21.1 Rejection:

21.1.1 Material that fails to conform to the requirements of this specification when inspected or tested by the purchaser, or purchaser's agent, may be rejected.

21.1.2 Rejection shall be reported to the manufacturer, or supplier, promptly and in writing.

21.1.3 In case of dissatisfaction with results of the test upon which rejection is based, the manufacturer, or supplier, may make claim for a rehearing.

21.2 *Rehearing*—As a result of product rejection, the manufacturer, or supplier, may make claim for a retest to be conducted by the manufacturer, or supplier, and the purchaser. Samples of the rejected product shall be taken in accordance with the product specification and subjected to test by both parties using the test method(s) specified in the product specification. Alternately, upon agreement of both parties, an independent laboratory may be selected for the test(s) using the test method(s) specified in the product specification.

## 22. Certification

22.1 When specified in the purchase order or contract, a manufacturer's certificate of compliance shall be furnished to the purchaser stating that samples representing each lot have been tested and inspected in accordance with this specification and the requirements have been met.

22.2 When material is specified to meet the requirement of ASME Boiler and Pressure Vessel Code, certification is mandatory.

## 23. Mill Test Report

23.1 When specified in the purchase order or contract, the manufacturer or supplier shall furnish to the purchaser a manufacturer's test report showing the results of the required tests.

## 24. Packaging and Package Marking

24.1 The material shall be separated by alloy, size, and temper. It shall be packaged in such a manner as to ensure

acceptance by common carrier for transportation and to afford adequate protection from normal hazards of transportation.

24.2 Each shipping unit shall be legibly marked with the name of supplier, purchase order number, metal or alloy designation, temper, size, total length or piece count, or both.

24.3 The specification number shall be shown when specified.

## 25. Keywords

25.1 condenser; copper; copper alloys; heat exchanger; integral fins; seamless; tube; UNS No. C10100; UNS No. C10200; UNS No. C10300; UNS No. C10800; UNS No. C12000; UNS No. C12200; UNS No. C14200; UNS No. C15630; UNS No. C19200; UNS No. C23000; UNS No. C44300; UNS No. C44400; UNS No. C44500; UNS No. C60800; UNS No. C68700; UNS No. C70400; UNS No. C70600; UNS No. C70620; UNS No. C71000; UNS No. C71500; UNS No. C71520; UNS No. C72200

## SUPPLEMENTARY REQUIREMENTS

The following supplementary requirements shall apply only when specified by the purchaser in the inquiry, contract, or order, for agencies of the U.S. Government.

### S1. Referenced Documents

S1.1 The following documents of the issue in effect on date of material purchase form a part of this specification to the extent referenced herein.

S1.1.1 *ASTM Standards*:<sup>3</sup>

B900 Practice for Packaging of Copper and Copper-Alloy Mill-Products for U.S. Government Agencies

D4727/D4727M Specification for Corrugated and Solid Fiberboard Sheet Stock (Container Grade) and Cut Shapes

S1.1.2 *Military Standards*:<sup>6</sup>

MIL-STD-271 Nondestructive Testing Requirements for Metals

MIL-STD-2035 Nondestructive Testing Acceptance Criteria

S1.1.3 *Military Specifications*:<sup>6</sup>

MIL-L-19140 Lumber and Plywood, Fire-Retardant Treated

### S2. Standard Government Tube Dimensions

S2.1 *Number of Fins*—Tube shall have  $19 + 1$ ,  $-0$  fins per inch as averaged over any 12 in. length.

S2.2 *Fin Height*—The fin height shall be 0.050 in., minimum.

S2.3 *Dimensions*—Table S2.1 lists standard tube diameters and wall thickness.

S2.4 *Root Diameter Tolerances*—A tolerance of  $+0.007$  in. and  $-0.003$  in. on the root diameter shall be permitted.

S2.5 *Straightness Tolerance*—The straightness tolerances of Table S2.2 shall apply to as-finned tube only.

S2.6 The tolerances for outside diameter of the unenhanced ends, specified in Table 4, shall be all negative.

### S3. Sampling

S3.1 *Lot Definition*—For sampling purposes, a lot shall consist of lengths of tubes of the same composition, temper, size, heat treated at the same time in the same furnace, offered for delivery at the same time and identifiable by mill records as originating from one or more heats (melts), as necessary, which conform to the chemical requirements. The total weight of the lot shall not exceed 10 000 lb.

S3.2 *Visual and Dimensional Examination*—From each lot, a representative sample of tubes shall be selected in accordance with Table S3.1 for inspection to the requirements of Section 13 Dimensions and Permissible Variations and Section 14 Workmanship, Finish and Appearance of this specification and Section 2 of this supplement.

S3.3 *Destructive Tests*—From each lot a representative sample for flattening, flaring, and grain size tests as specified in this specification shall be selected in accordance with Table S3.2.

S3.4 *Chemical Analysis*—Samples shall be taken at the time the metal is cast. One sample shall be taken for each group of castings poured from the same source of molten metal. Analysis of all metal compromising the lot shall be performed.

### S4. Nondestructive Testing

S4.1 *Eddy Current and Pressure Tests*—Both eddy current and pressure tests are required.

S4.2 *Eddy Current Procedure*—An eddy current test shall be performed which meets the requirements specified in this specification and MIL-STD-271.

<sup>6</sup> Available from DLA Document Services, Building 4/D, 700 Robbins Ave., Philadelphia, PA 19111-5094, <http://quicksearch.dla.mil>.

TABLE S2.1 Dimensions of Integrally Finned Condenser Tubes

Nominal		Unenhanced Section		Enhanced Section	
Outside Diameter, in.	Wall Thickness, in.	Specified Outside Diameter, in.	Wall Thickness, min., in.	Specified Root Diameter, in.	Wall Thickness, min., in.
1/2	0.032	0.500	0.049	0.375	0.032
1/2	0.042	0.500	0.058	0.375	0.042
1/2	0.049	0.500	0.065	0.375	0.049
5/8	0.028	0.625	0.042	0.500	0.028
5/8	0.035	0.625	0.049	0.500	0.035
5/8	0.049	0.625	0.065	0.500	0.049
5/8	0.058	0.625	0.072	0.500	0.058
5/8	0.065	0.625	0.083	0.500	0.065
3/4	0.028	0.750	0.049	0.625	0.028
3/4	0.035	0.750	0.052	0.625	0.035
3/4	0.042	0.750	0.058	0.625	0.042
3/4	0.049	0.750	0.065	0.625	0.049
3/4	0.058	0.750	0.075	0.625	0.058
3/4	0.065	0.750	0.083	0.625	0.065
3/4	0.072	0.750	0.086	0.625	0.072
3/4	0.083	0.750	0.095	0.625	0.083
3/4	0.095	0.750	0.109	0.625	0.095
7/8	0.035	0.875	0.052	0.750	0.035
7/8	0.042	0.875	0.058	0.750	0.042
7/8	0.049	0.875	0.065	0.750	0.049
7/8	0.058	0.875	0.075	0.750	0.058
7/8	0.065	0.875	0.083	0.750	0.065
7/8	0.072	0.875	0.086	0.750	0.072
7/8	0.083	0.875	0.095	0.750	0.083
1	0.042	1.000	0.058	0.875	0.042
1	0.049	1.000	0.065	0.875	0.049
1	0.058	1.000	0.075	0.875	0.058
1	0.065	1.000	0.083	0.875	0.065
1	0.072	1.000	0.086	0.875	0.072
1	0.083	1.000	0.095	0.875	0.083

TABLE S2.2 Permissible Variations in Straightness of Tube

Length, ft	Maximum Curvature (depth of arc), in.
Over 3 to 6 inclusive	3/16
Over 6 to 8 inclusive	5/16
Over 8 to 10 inclusive	1/2
Over 10	1/2 in. in any 10 ft portion of the total length

TABLE S3.2 Sampling for Destructive Tests

Lot Size	Sample Size
1–25	2
26–50	3
51–90	4
91–150	5
151–280	6
281–500	7
501–1200	8
1201–3200	9

TABLE S3.1 Sampling for Visual and Dimensional Examinations

Lot Size	Sample Size
2–13	All
14–150	13
151–280	20
281–500	29
501–1200	34
1201–3200	42

S4.2.1 *Liquid Penetrant Inspection*—Liquid penetrant inspection in accordance with MIL-STD-271 shall be performed on the outside surface and the end surfaces of the smooth ends of the tubes to inspect the area of the tubes missed by the eddy current test due to “end effect.” Alternatively, the area of the tube ends missed may be cropped off and discarded. Liquid penetrant acceptance criteria shall be in accordance with MIL-STD-2035.

## S5. Cleaning

S5.1 *Cleanliness*—Contaminants, such as sulfur or sulfur-bearing compounds or carbon or carbon compounds from lubricants used in forming, machining, or other processing and

marking materials used for in-process identification, shall be removed from the material prior to any heat treatment. Tubing shall be acid or abrasive cleaned. Traces of acid or abrasive shall be removed following cleaning.

## S6. Preparation for Delivery

S6.1 *Military Agencies*—Material shall be separated by size, and composition and shall be preserved and packaged level A or C, packed level A, B, or C, as specified in the purchase order or contract in accordance with the requirements of Practice B900. In addition when specified in the contract or purchase order the following shall apply:

### S6.1.1 *Fire Retardant Requirements:*

S6.1.1.1 *Lumber and Plywood*—All lumber and plywood including laminated veneer materials used in shipping container and pallet construction, members, blocking, bracing, and reinforcing shall be fire retardant treated materials conforming to MIL-L-19140 as follows:

Level A and B	Type II—weather resistant Category I—general use
Level C	Type I—non weather resistant Category I—general use

S6.1.1.2 *Fiberboard*—Fiberboard used in the construction of boxes including interior packaging forms shall conform to the class-domestic/fire retardant or class-weather resistant/fire retardant materials requirements, as specified in the acquisition document, of Specification D4727/D4727M.

S6.1.2 Cushioning or wrapping materials shall be provided to prevent damage and to prevent free movement of the container contents. The use of excelsior, newspaper, shredded paper and similar hygroscopic or non-neutral materials and all types of loose fill materials for packaging applications such as cushioning, fill, stuffing and dunnage is prohibited.

## SUMMARY OF CHANGES

Committee B05 has identified the location of selected changes to this standard since the last issue (B359/B359M – 18) that may impact the use of this standard. (Approved Oct. 1, 2023.)

(1) Added temper H80 in Table 2, Table 3, and 8.1.1.2.

*ASTM International takes no position respecting the validity of any patent rights asserted in connection with any item mentioned in this standard. Users of this standard are expressly advised that determination of the validity of any such patent rights, and the risk of infringement of such rights, are entirely their own responsibility.*

*This standard is subject to revision at any time by the responsible technical committee and must be reviewed every five years and if not revised, either reapproved or withdrawn. Your comments are invited either for revision of this standard or for additional standards and should be addressed to ASTM International Headquarters. Your comments will receive careful consideration at a meeting of the responsible technical committee, which you may attend. If you feel that your comments have not received a fair hearing you should make your views known to the ASTM Committee on Standards, at the address shown below.*

*This standard is copyrighted by ASTM International, 100 Barr Harbor Drive, PO Box C700, West Conshohocken, PA 19428-2959, United States. Individual reprints (single or multiple copies) of this standard may be obtained by contacting ASTM at the above address or at 610-832-9585 (phone), 610-832-9555 (fax), or service@astm.org (e-mail); or through the ASTM website (www.astm.org). Permission rights to photocopy the standard may also be secured from the Copyright Clearance Center, 222 Rosewood Drive, Danvers, MA 01923, Tel: (978) 646-2600; http://www.copyright.com/*

# SPECIFICATION FOR SEAMLESS AND WELDED UNALLOYED TITANIUM AND TITANIUM ALLOY WELDING FITTINGS



**SB-363**

(Identical with ASTM Specification B363-14 except that certification and a test report have been made mandatory, and Supplementary Requirement S5 is mandatory.)

# Standard Specification for Seamless and Welded Unalloyed Titanium and Titanium Alloy Welding Fittings

## 1. Scope

1.1 This specification covers fittings intended for general corrosion-resisting and elevated-temperature services, factory made from unalloyed titanium and titanium alloys. The term welding fittings applies to butt-welding parts such as 45° and 90° elbows, 180° returns, caps, tees, reducers, lap-joint stub ends, and other types.

1.2 *This standard does not purport to address all of the safety concerns, if any, associated with its use. It is the responsibility of the user of this standard to establish appropriate safety and health practices and determine the applicability of regulatory limitations prior to use.*

## 2. Referenced Documents

### 2.1 ASTM Standards:

- B265 Specification for Titanium and Titanium Alloy Strip, Sheet, and Plate
- B338 Specification for Seamless and Welded Titanium and Titanium Alloy Tubes for Condensers and Heat Exchangers
- B348 Specification for Titanium and Titanium Alloy Bars and Billets
- B367 Specification for Titanium and Titanium Alloy Castings
- B381 Specification for Titanium and Titanium Alloy Forgings
- B600 Guide for Descaling and Cleaning Titanium and Titanium Alloy Surfaces
- B861 Specification for Titanium and Titanium Alloy Seamless Pipe

B862 Specification for Titanium and Titanium Alloy Welded Pipe

### 2.2 ANSI Standards:

- ASME/ANSI B16.5 Pipe Flanges and Flanged Fittings
- ASME/ANSI B16.9 Wrought Steel Butt-Welding Fittings
- ASME/ANSI B16.11 Forged Fittings, Socket Welding and Threaded
- ASME/ANSI B36.19 Stainless Steel Pipe

### 2.3 Manufacturers' Standardization Society of the Valve and Fittings Industry Standards:

- MSS SP-25 Standard Marking System for Valves, Fittings, Flanges and Unions
- MSS SP-43 Standard Practice for Light Weight Stainless Steel Butt-Welding Fittings
- MSS SP-97 Standard Integrally Reinforced Forged Branch Outlet Fittings — Socket Welding, Threaded, and Butt-Welding Ends
- MSS SP-119 Standard Factory-Made Wrought Belled End Socket-Welding Fittings

### 2.4 ASME Standard:

- ASME Boiler and Pressure Vessel Code Sections VIII Division 1 Pressure Vessels and Section IX

## 3. Ordering Information

3.1 Orders for material to this specification shall include the following information as required:

- 3.1.1 Quantity,
- 3.1.2 Grade number,
- 3.1.3 Pipe size and schedule,
- 3.1.4 Method of manufacture and finish,

- 3.1.5 Restrictive chemistry, if desired,
- 3.1.6 Nondestructive tests,
- 3.1.7 Packaging,
- 3.1.8 Inspection and required reports,
- 3.1.9 Appropriate fittings specifications for dimensions only, and
- 3.1.10 Class, as required.

**4. Material**

4.1 The titanium for welding fittings may consist of billets, bars, plates, castings, seamless or welded pipe or tube that conforms to all the requirements for manufacturing process, testing, chemical composition, and mechanical properties prescribed in Specifications B861 and B862 for the particular grades referred to in Table 1.

**5. Manufacture**

5.1 Forging, forming, or shaping operations may be performed by hammering, pressing, piercing, extruding, upsetting, rolling, bending, fusion welding, or by a combination of two or more of these operations. The forming procedure shall be so applied that it will not produce injurious defects in the fittings.

5.2 Fittings containing welded seams or other joints made by fusion welding shall comply with the following provision:

5.2.1 Welded by welders, welding operators, and welding procedures qualified under the provisions of Section IX of the ASME Boiler and Pressure Vessel Code.

5.2.2 Supplementary requirement S5 is mandatory.

**TABLE 2 Permissible Variations in Product Analysis**

Element	Product Analysis Limits, max or Range, %	Permissible Variation in Product Analysis
Aluminum	0.5 to 2.5	±0.20
Aluminum	2.5 to 6.75	±0.40
Carbon	0.10	+0.02
Chromium	0.1 to 0.2	±0.02
Chromium	5.5 to 6.5	±0.30
Hydrogen	0.02	+0.002
Iron	0.80	+0.15
Iron	1.2 to 1.8	±0.20
Molybdenum	0.2 to 0.4	±0.03
Molybdenum	1.5 to 4.5	±0.20
Molybdenum	14.0 to 16.0	±0.50
Nickel	0.3 to 0.9	±0.05
Niobium	2.2 to 3.2	±0.15
Niobium	>30	±0.50
Nitrogen	0.05	+0.02
Oxygen	0.30	+0.03
Oxygen	0.31 to 0.40	±0.04
Palladium	0.01 to 0.02	±0.002
Palladium	0.04 to 0.08	±0.005
Palladium	0.12 to 0.25	±0.02
Ruthenium	0.02 to 0.04	±0.005
Ruthenium	0.04 to 0.06	±0.005
Ruthenium	0.08 to 0.14	±0.01
Silicon	0.06 to 0.40	±0.02
Vanadium	2.0 to 4.5	±0.15
Vanadium	7.5 to 8.5	±0.40
Zirconium	3.5 to 4.5	±0.20
Residuals <sup>A</sup> (each)	0.15	+0.02

<sup>A</sup> A residual is an element present in a metal or alloy in small quantities and is inherent to the manufacturing process but not added intentionally. In titanium these elements include aluminum, vanadium, tin, iron, chromium, molybdenum, niobium, zirconium, hafnium, bismuth, ruthenium, palladium, yttrium, copper, silicon, cobalt, tantalum, nickel, boron, manganese, and tungsten.

**TABLE 1 Permissible Raw Materials**

Grade <sup>A</sup>	Product and ASTM Designation					
	Pipe	Tube	Plate	Bar and Billet	Casting	Forging
WPT1	B861/B862 Grade 1	B338 Grade 1	B265 Grade 1	B348 Grade 1	B367 Grade C1	B381 Grade F-1
WPT2	B861/B862 Grade 2	B338 Grade 2	B265 Grade 2	B348 Grade 2	B367 Grade C2	B381 Grade F-2
WPT2H	B861/B862 Grade 2H	B338 Grade 2H	B265 Grade 2H	B348 Grade 2H	...	B381 Grade F-2H
WPT3	B861/B862 Grade 3	B338 Grade 3	B265 Grade 3	B348 Grade 3	B367 Grade C3	B381 Grade F-3
WPT7	B861/B862 Grade 7	B338 Grade 7	B265 Grade 7	B348 Grade 7	B367 Grade C7	B381 Grade F-7
WPT7H	B861/B862 Grade 7H	B338 Grade 7H	B265 Grade 7H	B348 Grade 7H	...	B381 Grade F-7H
WPT9	B861/B862 Grade 9	B338 Grade 9	B265 Grade 9	B348 Grade 9	...	B381 Grade F-9
WPT11	B861/B862 Grade 11	B338 Grade 11	B265 Grade 11	B348 Grade 11	B367 Grade C11	B381 Grade F-11
WPT12	B861/B862 Grade 12	B338 Grade 12	B265 Grade 12	B348 Grade 12	...	B381 Grade F-12
WPT13	B861/B862 Grade 13	B338 Grade 13	B265 Grade 13	B348 Grade 13	...	B381 Grade F-13
WPT14	B861/B862 Grade 14	B338 Grade 14	B265 Grade 14	B348 Grade 14	...	B381 Grade F-14
WPT15	B861/B862 Grade 15	B338 Grade 15	B265 Grade 15	B348 Grade 15	...	B381 Grade F-15
WPT16	B861/B862 Grade 16	B338 Grade 16	B265 Grade 16	B348 Grade 16	...	B381 Grade F-16
WPT16H	B861/B862 Grade 16H	B338 Grade 16H	B265 Grade 16H	B348 Grade 16H	...	B381 Grade F-16H
WPT17	B861/B862 Grade 17	B338 Grade 17	B265 Grade 17	B348 Grade 17	...	B381 Grade F-17
WPT18	B861/B862 Grade 18	B338 Grade 18	B265 Grade 18	B348 Grade 18	...	B381 Grade F-18
WPT19	B861/B862 Grade 19	...	B265 Grade 19	B348 Grade 19	...	B381 Grade F-19
WPT20	B861/B862 Grade 20	...	B265 Grade 20	B348 Grade 20	...	B381 Grade F-20
WPT21	B861/B862 Grade 21	...	B265 Grade 21	B348 Grade 21	...	B381 Grade F-21
WPT23	B861/B862 Grade 23	...	B265 Grade 23	B348 Grade 23	...	B381 Grade F-23
WPT24	B861/B862 Grade 24	...	B265 Grade 24	B348 Grade 24	...	B381 Grade F-24
WPT25	B861/B862 Grade 25	...	B265 Grade 25	B348 Grade 25	...	B381 Grade F-25
WPT26	B861/B862 Grade 26	B338 Grade 26	B265 Grade 26	B348 Grade 26	...	B381 Grade F-26
WPT26H	B861/B862 Grade 26H	B338 Grade 26H	B265 Grade 26H	B348 Grade 26H	...	B381 Grade F-26H
WPT27	B861/B862 Grade 27	B338 Grade 27	B265 Grade 27	B348 Grade 27	...	B381 Grade F-27
WPT28	B861/B862 Grade 28	B338 Grade 28	B265 Grade 28	B348 Grade 28	...	B381 Grade F-28
WPT33	B861/B862 Grade 33	B338 Grade 33	B265 Grade 33	B348 Grade 33	...	B381 Grade F-33
WPT34	B861/B862 Grade 34	B338 Grade 34	B265 Grade 34	B348 Grade 34	...	B381 Grade F-34
WPT35	B861/B862 Grade 35	B338 Grade 35	B265 Grade 35	B348 Grade 35	...	B381 Grade F-35
WPT36	B861/B862 Grade 36	B338 Grade 36	B265 Grade 36	B348 Grade 36	...	B381 Grade F-36
WPT37	B861/B862 Grade 37	B338 Grade 37	B265 Grade 37	B348 Grade 37	...	B381 Grade F-37
WPT38	B861/B862 Grade 38	B338 Grade 38	B265 Grade 38	B348 Grade 38	...	B381 Grade F-38

<sup>A</sup> When fittings are of welded construction, the symbol shown shall be supplemented by the letter "W."

NOTE 1—Annealing of the unalloyed and alloyed grades of titanium covered by this specification is for the purpose of assuring uniform properties.

## 6. Chemical Composition

6.1 The titanium shall conform to the requirements as to chemical composition prescribed in the specifications referred to in Table 1.

6.2 The chemical analysis of the components of the fittings need not be reported unless required by agreement between the manufacturer and the purchaser and so specified on the order.

## 7. Product Analysis

7.1 Product analysis may be made by the purchaser from one or more fittings in each lot.

NOTE 2—Definition of the term “lot” shall be as agreed upon between the manufacturer and the purchaser.

7.2 Product analysis tolerances do not broaden the specified heat analysis requirements, but cover variations between different laboratories in the measurement of chemical content. The manufacturer shall not ship material that is outside the limits specified for the applicable grade. Product analysis tolerances shall be as specified in Table 2.

## 8. Tensile Properties

8.1 The titanium shall conform to the requirements as to tensile properties prescribed in the specifications referred to in Table 1.

8.2 Tensile tests of the finished fittings need not be reported unless required by agreement between the manufacturer and the purchaser and so stated in the order.

## 9. Workmanship, Finish, and Appearance

9.1 For fittings covered by ASME/ANSI B16.5, ASME/ANSI B16.9 or ASME/ANSI B16.11, MSS SP-43, MSS SP-97, or MSS SP-119 or for fittings to be used with pipe ordered to ASME/ANSI B36.19, or as attachments such as caps, plugs, etc., the sizes, shapes, and dimensions of the fittings shall be as specified in those standards.

9.2 The fittings shall have a workmanlike finish and shall be free of injurious external and internal imperfections of a nature that will interfere with the purpose for which the fittings are intended. Minor defects may be removed by grinding, providing the wall thickness is not decreased to less than the minimum thickness, and further provided that the ground-out area shall be faired out.

## 10. Hydrostatic Tests

10.1 All fittings shall be capable of withstanding without failure, leakage, or impairment of their serviceability, a test pressure prescribed in the specifications for the pipe or tubing

with which the fitting is recommended to be used (see Table 1). For sizes outside the capability for hydrostatic testing, consideration should be given to radiographic inspection in accordance with Section S2 under Supplementary Requirements.

10.2 Hydrostatic tests need not be performed or reported, unless required by agreement between the manufacturer and the purchaser and so stated on the order.

## 11. Inspection and Certification

11.1 Inspection by the purchaser prior to shipment shall be specified in the purchase order.

11.2 The manufacturer shall afford the inspector, without charge, all reasonable facilities to satisfy him that the fittings are being furnished in accordance with this specification. Any tests (except product analysis) and inspection agreed upon and so stated in the purchase order shall be made at the place of manufacture, unless otherwise specified, and shall be so conducted as not to interfere unnecessarily with the operation of the works.

11.3 *Certification*—The manufacturer shall furnish the purchaser a certificate that the finished fittings conform to the requirements of this specification. The certification shall include a report of the test results.

NOTE 3—It is recognized that a sensitive surface inspection of the welds or base metal, or both, is advisable for some services. See Supplementary Requirements.

## 12. Rejection

12.1 Material not conforming to this specification or to authorized modifications shall be subject to rejection. Unless otherwise specified, rejected material may be returned to the manufacturer at the manufacturer's expense, unless the purchaser receives, within 3 weeks of notice of rejection, other instructions for disposition.

## 13. Product Marking

13.1 The manufacturer's name or trademark, the schedule number, material, and size shall be stamped (Note 4), stenciled, electroetched, or otherwise suitably marked on each fitting. In addition, each fitting shall be marked with the identification symbol and suffix for the respective specification listed in Table 1. On wall thicknesses thinner than Schedule 40S, no stamps or other indented markings shall be used. When the size does not permit complete marking, identification marks may be omitted in the sequence shown in MSS SP-25.

NOTE 4—When steel stamps are used, they should be applied prior to heat treatment and care should be taken so that the marking is not deep enough to cause cracks or to reduce the wall thickness of the fitting below the minimum allowed.

## 14. Keywords

14.1 fittings; seamless fittings; titanium; titanium alloy; welded fittings

**SUPPLEMENTARY REQUIREMENTS**

Supplementary requirements shall not be considered unless specified in the order, in which event the test shall be made by the manufacturer at the purchaser's expense.

**S1. Surface Inspection**

S1.1 Liquid penetrant inspection may be performed on all outside-diameter surfaces of the fittings and inside-diameter surfaces where practicable. An acceptance standard may be agreed upon between the manufacturer and the purchaser prior to the acceptance of the order.

**S2. Radiographic Inspections of Welds**

S2.1 Radiographic inspection may be performed on all weldments of the fittings in accordance with paragraph UW-51, Section VIII of the ASME Boiler and Pressure Vessel Code.

**S3. Stress Relief Heat Treatment**

S3.1 The stress-relieving treatment shall consist of holding the fitting at a minimum temperature of 1100°F for not less than ½ h/in. of thickness.

S3.2 Minimum time at temperature is 15 min. All parts stress relieved shall be subsequently cleaned and free of oxide scale contamination (see Guide B600).

**S4. Certification of Material Incorporated in the Manufacture of the Fittings**

S4.1 All material incorporated within the fitting shall be documented and shall be in accordance with the applicable documents in Table 1.

**S5. Certification of Fittings for use in ASME BPV Construction, Section VIII**

S5.1 All fittings welded with filler metal intended for applications under the rules of Section VIII, Division 1 of the ASME Boiler and Pressure Vessel Code shall conform to the following: Manufacturer of such products are limited to manufacturers holding the appropriate ASME Certificate of Authorization and Code Certification Mark. In addition to conforming to this specification, the manufacturer shall meet all applicable requirements of Section VIII, Division 1 of the Code. The materials used to fabricate the fitting shall conform to ASME SB Specifications. The product shall be subject to all applicable requirements of Section VIII, Division 1 of the Code, including welding, heat treatment, nondestructive examination, authorized inspections at point of manufacture, and application of the Code Certification Mark.

The applicable ASME Partial Data Report Form signed by an Authorized Inspector and a certified mill test report shall be furnished for each lot of fittings. The term "lot" applies to all fittings of the same mill heat of material, size, and wall thickness, which are heat treated, if applicable, in one furnace charge. Each fitting shall be marked in such a manner to identify each such piece with the "lot" and the certified mill test report.

ASMENORMDOC.COM : Click to view the full PDF of ASME BPVC.II.B (ASME BPVC Section II part B) 2025

INTENTIONALLY LEFT BLANK

## SPECIFICATION FOR FACTORY-MADE WROUGHT NICKEL AND NICKEL ALLOY FITTINGS



**SB-366/SB-366M**

(Identical with ASTM Specification B366/B366M-17 except that listed heat treatments are mandatory in para. 5.3; changes have been made to the heat treatment temperature of alloys UNS N06025 and UNS N06210 in Table 3; and in section 7, fittings made from forging stock are required to be tested and meet specification mechanical properties.)

# Specification for Factory-Made Wrought Nickel and Nickel Alloy Fittings

## 1. Scope

1.1 This specification covers wrought welding fittings for pressure piping, factory-made from nickel and nickel alloys. Threaded fittings as covered in ASME B16.11 are also covered by this specification. The term welding applies to butt-welding or socket-welding parts such as 45° and 90° elbows, 180° bends, caps, tees, reducers, lap-joint stub ends, and other types, as covered by ASME B16.9, ASME B16.11, MSS SP-43, MSS SP-95, and MSS SP-97.

1.1.1 Several grades of nickel and nickel alloys are included in this specification. Grades are designated with a prefix, WP or CR, based on the applicable ASME or MSS dimensional and rating standards.

1.1.2 Class WP fittings are those manufactured to the requirements of ASME B16.9, B16.11.

1.1.3 For each of the WP nickel and nickel alloy grades, several classes of fittings are covered to indicate whether seamless or welded construction was utilized. Class designations are also utilized to indicate the nondestructive test method and extent of nondestructive examination (NDE). Table 1 is general summary of the fitting classes applicable to all WP grades of nickel and nickel alloys covered by this specification. There are no classes for the CR grades. Specific requirements are covered elsewhere.

1.2 This specification does not apply to cast welding fittings.

1.3 Optional supplementary requirements are provided for fittings where a greater degree of examination is desired. These supplementary requirements call for additional tests. When desired, one or more of these may be specified in the order.

1.4 The values stated in either SI units or inch-pound units are to be regarded separately as standard. The values stated in each system may not be exact equivalents; therefore, each system shall be used independently of the other. Combining values from the two systems may result in non-conformance with the standard.

1.5 This standard does not purport to address all of the safety concerns, if any, associated with its use. It is the responsibility of the user of this standard to become familiar with all hazards including those identified in the appropriate Safety Data Sheet (SDS) for this product/material as provided by the manufacturer, to establish appropriate safety and health practices, and determine the applicability of regulatory limitations prior to use.

1.6 This international standard was developed in accordance with internationally recognized principles on standardization established in the Decision on Principles for the Development of International Standards, Guides and Recommendations issued by the World Trade Organization Technical Barriers to Trade (TBT) Committee.

## 2. Referenced Documents

### 2.1 ASTM Standards:

- B127 Specification for Nickel-Copper Alloy (UNS N04400) Plate, Sheet, and Strip
- B160 Specification for Nickel Rod and Bar
- B161 Specification for Nickel Seamless Pipe and Tube
- B162 Specification for Nickel Plate, Sheet, and Strip
- B163 Specification for Seamless Nickel and Nickel Alloy Condenser and Heat-Exchanger Tubes
- B164 Specification for Nickel-Copper Alloy Rod, Bar, and Wire
- B165 Specification for Nickel-Copper Alloy (UNS N04400) Seamless Pipe and Tube
- B166 Specification for Nickel-Chromium-Iron Alloys (UNS N06600, N06601, N06603, N06690, N06693, N06025, N06045, and N06696), Nickel-Chromium-Cobalt-Molybdenum Alloy (UNS N06617), and Nickel-Iron-Chromium-Tungsten Alloy (UNS N06674) Rod, Bar, and Wire
- B167 Specification for Nickel-Chromium-Iron Alloys (UNS N06600, N06601, N06603, N06690, N06693, N06025, N06045, and N06696), Nickel-Chromium-Cobalt-Molybdenum Alloy (UNS N06617), and Nickel-Iron-Chromium-Tungsten Alloy (UNS N06674) Seamless Pipe and Tube

TABLE 1 Fitting Classes for WP Grades

Class	Construction	Nondestructive Examination
S	Seamless	None
W	Welded	Radiography or Ultrasonic
WX	Welded	Radiography
WU	Welded	Ultrasonic

B168 Specification for Nickel-Chromium-Iron Alloys (UNS N06600, N06601, N06603, N06690, N06693, N06025, N06045, and N06696), Nickel-Chromium-Cobalt-Molybdenum Alloy (UNS N06617), and Nickel-Iron-Chromium-Tungsten Alloy (UNS N06674) Plate, Sheet, and Strip

B333 Specification for Nickel-Molybdenum Alloy Plate, Sheet, and Strip

B335 Specification for Nickel-Molybdenum Alloy Rod

B407 Specification for Nickel-Iron-Chromium Alloy Seamless Pipe and Tube

B408 Specification for Nickel-Iron-Chromium Alloy Rod and Bar

B409 Specification for Nickel-Iron-Chromium Alloy Plate, Sheet, and Strip

B423 Specification for Nickel-Iron-Chromium-Molybdenum-Copper Alloy (UNS N08825, N08221, and N06845) Seamless Pipe and Tube

B424 Specification for Ni-Fe-Cr-Mo-Cu Alloy (UNS N08825, UNS N08221, and UNS N06845) Plate, Sheet, and Strip

B425 Specification for Ni-Fe-Cr-Mo-Cu Alloy (UNS N08825, UNS N08221, and UNS N06845) Rod and Bar

B434 Specification for Nickel-Molybdenum-Chromium-Iron Alloys (UNS N10003, UNS N10242) Plate, Sheet, and Strip

B435 Specification for UNS N06002, UNS N06230, UNS N12160, and UNS R30556 Plate, Sheet, and Strip

B443 Specification for Nickel-Chromium-Molybdenum-Columbium Alloy (UNS N06625) and Nickel-Chromium-Molybdenum-Silicon Alloy (UNS N06219) Plate, Sheet, and Strip

B444 Specification for Nickel-Chromium-Molybdenum-Columbium Alloys (UNS N06625 and UNS N06852) and Nickel-Chromium-Molybdenum-Silicon Alloy (UNS N06219) Pipe and Tube

B446 Specification for Nickel-Chromium-Molybdenum-Columbium Alloy (UNS N06625), Nickel-Chromium-Molybdenum-Silicon Alloy (UNS N06219), and Nickel-Chromium-Molybdenum-Tungsten Alloy (UNS N06650) Rod and Bar

B462 Specification for Forged or Rolled UNS N06030, UNS N06022, UNS N06035, UNS N06200, UNS N06059, UNS N10362, UNS N06686, UNS N08020, UNS N08367, UNS N10276, UNS N10665, UNS N10675, UNS N10629, UNS N08031, UNS N06045, UNS N06025, UNS R20033 Alloy Pipe Flanges, Forged Fittings

B463 Specification for UNS N08020 Alloy Plate, Sheet, and Strip

B464/B464M Specification for Welded UNS N08020 Alloy Pipe

B468 Specification for Welded UNS N08020 Alloy Tubes

B472 Specification for Nickel Alloy Billets and Bars for Reforging

B473 Specification for UNS N08020, UNS N08024, and UNS N08026 Nickel Alloy Bar and Wire

B511 Specification for Nickel-Iron-Chromium-Silicon Alloy Bars and Shapes

B512 Specification for Nickel-Chromium-Silicon Alloy (UNS N08330) Billets and Bars

B514 Specification for Welded Nickel-Iron-Chromium Alloy Pipe

B515 Specification for Welded UNS N08120, UNS N08800, UNS N08810, and UNS N08811 Alloy Tubes

B516 Specification for Welded Nickel-Chromium-Iron Alloy (UNS N06600, UNS N06601, UNS N06603, UNS N06025, UNS N06045, UNS N06690, and UNS N06693) Tubes

B517 Specification for Welded Nickel-Chromium-Iron Alloy (UNS N06600, UNS N06603, UNS N06025, and UNS N06045) Pipe

B535 Specification for Nickel-Iron-Chromium-Silicon Alloys (UNS N08330 and N08332) Seamless Pipe and Tube

B536 Specification for Nickel-Iron-Chromium-Silicon Alloys (UNS N08330 and N08332) Plate, Sheet, and Strip

B564 Specification for Nickel Alloy Forgings

B572 Specification for UNS N06002, UNS N06230, UNS N12160, and UNS R30556 Rod

B573 Specification for Nickel-Molybdenum-Chromium-Iron Alloys (UNS N10003, N10242) Rod

B574 Specification for Low-Carbon Nickel-Chromium-Molybdenum, Low-Carbon Nickel-Molybdenum-Chromium, Low-Carbon Nickel-Molybdenum-Chromium-Tantalum, Low-Carbon Nickel-Chromium-Molybdenum-Copper, and Low-Carbon Nickel-Chromium-Molybdenum-Tungsten Alloy Rod

B575 Specification for Low-Carbon Nickel-Chromium-Molybdenum, Low-Carbon Nickel-Chromium-Molybdenum-Copper, Low-Carbon Nickel-Chromium-Molybdenum-Tantalum, Low-Carbon Nickel-Chromium-Molybdenum-Tungsten, and Low-Carbon Nickel-Molybdenum-Chromium Alloy Plate, Sheet, and Strip

B581 Specification for Nickel-Chromium-Iron-Molybdenum-Copper Alloy Rod

B582 Specification for Nickel-Chromium-Iron-Molybdenum-Copper Alloy Plate, Sheet, and Strip

B619/B619M Specification for Welded Nickel and Nickel-Cobalt Alloy Pipe

B622 Specification for Seamless Nickel and Nickel-Cobalt Alloy Pipe and Tube

B625 Specification for UNS N08925, UNS N08031, UNS N08932, UNS N08926, UNS N08354, UNS N08830, and UNS R20033 Plate, Sheet, and Strip

B626 Specification for Welded Nickel and Nickel-Cobalt Alloy Tube

B649 Specification for Ni-Fe-Cr-Mo-Cu-N Low-Carbon Alloys (UNS N08925, UNS N08031, UNS N08354, and

UNS N08926), and Cr-Ni-Fe-N Low-Carbon Alloy (UNS R20033) Bar and Wire, and Ni-Cr-Fe-Mo-N Alloy (UNS N08936) Wire

B673 Specification for UNS N08925, UNS N08354, and UNS N08926 Welded Pipe

B674 Specification for UNS N08925, UNS N08354, and UNS N08926 Welded Tube

B675 Specification for UNS N08367 Welded Pipe

B676 Specification for UNS N08367 Welded Tube

B677 Specification for UNS N08925, UNS N08354, and UNS N08926 Seamless Pipe and Tube

B688 Specification for Chromium-Nickel-Molybdenum-Iron (UNS N08366 and UNS N08367) Plate, Sheet, and Strip

B690 Specification for Iron-Nickel-Chromium-Molybdenum Alloys (UNS N08366 and UNS N08367) Seamless Pipe and Tube

B691 Specification for Iron-Nickel-Chromium-Molybdenum Alloys (UNS N08366 and UNS N08367) Rod, Bar, and Wire

B704 Specification for Welded UNS N06625, UNS N06219 and UNS N08825 Alloy Tubes

B705 Specification for Nickel-Alloy (UNS N06625, N06219 and N08825) Welded Pipe

B710 Specification for Nickel-Iron-Chromium-Silicon Alloy Welded Pipe

B729 Specification for Seamless UNS N08020, UNS N08026, and UNS N08024 Nickel-Alloy Pipe and Tube

B880 Specification for General Requirements for Chemical Check Analysis Limits for Nickel, Nickel Alloys and Cobalt Alloys

B899 Terminology Relating to Non-ferrous Metals and Alloys

E165 Practice for Liquid Penetrant Examination for General Industry

E1916 Guide for Identification of Mixed Lots of Metals

#### 2.2 ASME Standards:

B16.9 Wrought Steel Butt Welding Fittings

B16.11 Forged Steel Fittings, Socket-Welding and Threaded

#### 2.3 Manufacturers Standardization Society of the Valve and Fittings Industry Standards:

MSS SP-25 Standard Marking Systems for Valves, Fittings, Flanges, and Unions

MSS SP-43 Standard Practice for Light Weight Stainless Steel Butt Welding Fittings

MSS SP-95 Sewage (D) Nipples and Bull Plugs

MSS SP-97 Forged Carbon Steel Branch Outlet Fittings—Socket Welding, Threaded and Butt Welding Ends

Boiler and Pressure Vessel Code, Section VIII, Division 1 Pressure Vessels and Section IX, Welding Qualifications

#### 2.4 AWS Standards:

A5.11 Specification for Nickel and Nickel Alloy Covered Welding Electrodes

A5.14 Specification for Nickel and Nickel-Alloy Bare Welding Rods and Electrodes

#### 2.5 ASNT:

SNT-TC-1A Recommended Practice for Nondestructive Testing Personnel Qualification and Certification

### 3. Terminology

3.1 Terms defined in Terminology B899 shall apply unless otherwise defined in this standard.

### 4. Ordering Information

4.1 It is the responsibility of the purchaser to specify all requirements that are necessary for material ordered under this specification. Examples of such requirements include, but are not limited to, the following:

4.1.1 Quantity, number of fittings of each kind,

4.1.2 Description of Fitting and Nominal Dimensions (standard or special),

4.1.3 Alloy Composition,

4.1.4 Condition (temper) if applicable.

4.1.5 If neither grade of N06625 is specified, Grade 1 will be supplied.

4.1.6 For each Grade of WP fittings ordered, a Class should also be indicated.

4.1.6.1 Grade **CR** fittings shall not be substituted for fittings ordered to Grade **WP**, but Grade **WP** may be substituted for Grade **CR**.

4.1.6.2 For all Classes of WP fittings, unless S, W, WX, or WU is specified by the purchaser, any class may be furnished at the option of the supplier.

4.1.7 *Purchaser Inspection*—State which tests or inspections are to be witnessed (Section 10),

4.1.8 *Samples for Product (Check Analysis)*—State whether samples should be furnished (6.3),

4.1.9 Test reports (Section 12), and

4.1.10 Supplementary requirements, if any.

### 5. Materials and Manufacture

5.1 *Material*—The material for wrought welding fittings may consist of forgings, rods, bars, plates, sheets, and seamless or welded pipe that conform to all the requirements of the ASTM specifications for the particular product and alloy referred to in Table 2.

#### 5.2 Manufacture:

5.2.1 Forging or shaping operations may be performed by hammering, pressing, piercing, extruding, upsetting, rolling, bending, or fusion welding, or by a combination of two or more of these operations. The forming procedure shall be so applied that it will not produce injurious defects in the fittings.

TABLE 2 Permissible Raw Materials

Corrosion-Resistant Fittings	Marking <sup>A</sup>		Product and ASTM Designation <sup>B</sup>			
	ASME Pressure Fittings	Alloy	UNS Designation	Pipe or Tube	Plate, Sheet, or Strip	Bar Forging and Forging Stock
CRN	WPN	Ni	N02200	B161	B162	B160, B564
CRNL	WPNL	Ni, Low C	N02201	B161	B162	B160
CRNC <sup>C</sup>	WPNC <sup>C</sup>	Ni-Cu	N04400	B165	B127	B164, B564
CR HX	WPHX	Ni-Cr-Mo-Fe	N06002	B619/B619M, B622, B626	B435	B572
CR HG	WPHG	Ni-Cr-Fe-Mo-Cu	N06007	B619/B619M, B622, B626	B582	B581
CR HC 22	WPHC22	Low C-Ni-Mo-Cr	N06022	B619/B619M, B622, B626	B575	B574, B564, B462, B472
CRV602	WPV602	Ni-Cr-Fe	N06025	B163, B167	B168	B166, B462, B472
CR HG 30	WPHG30	Ni-Cr-Fe-Mo-Cu	N06030	B619/B619M, B622, B626	B582	B581, B462, B472
CRHG35	WPHG35	Ni-Cr-Mo	N06035	B619/B619M, B622, B626	B575	B574, B564, B462, B472
CR MC	WPHMC	Ni-Cr-Mo	N06044	B619/B619M, B622, B626	B575	B574, B564
CRV45TM	WPV45TM	Ni-Cr-Fe	N06045	B163, B167	B168	B166, B462, B472
CR2120	WP2120	Ni-Cr-Mo low C	N06058	B619/B619M, B622, B626	B575	B564, B574
CR5923	WP5923	Low C-Ni-Cr-Mo	N06059	B619/B619M, B622, B626	B575	B564, B574, B462, B472
CR HC 2000	WPHC2000	Low C-Ni-Cr-Mo-Cu	N06200	B619/B619M, B622, B626	B575	B564, B574, B462, B472
CRM21	WPM21	Low C-Ni-Cr-Mo-Ta	N06210	B619/B619M, B622, B626	B575	B564, B574
CRH230	WPH230	Ni-Cr-W-Mo	N06230	B619/B619M, B622, B626	B435	B572, B564
CRHBC1	WPHBC1	Low C-Ni-Mo-Cr	N10362	B619/B619M, B622, B626	B575	B574, B564, B462, B472
CR HC 4	WPHC4	Low C-Ni-Mo-Cr	N06455	B619/B619M, B622, B626	B575	B574
CRNCI	WPNCI	Ni-Cr-Fe	N06600	B167, B516, B517	B168	B166, B564
CR603GT	WP603GT	Ni-Cr-Fe-Al	N06603	B163, B167, B516, B517	B168	B166, B564
CRNCMC	WPNCMC	Ni-Cr-Mo-Cb	N06625	B444, B704, B705	B443	B446, B564
CRIN686	WPIN686	Low C-Ni-Cr-Mo	N06686	B163, B619/B619M, B622, B626	B575	B564, B574, B462, B472
CR626Si	WP626Si	Ni-Cr-Mo-Si	N06219	B444, B704, B705	B443	B446, B564
CR HG3	WPHG3	Ni-Cr-Fe-Mo-Cu	N06985	B619/B619M, B622, B626	B582	B581
CR20CB	WP20CB	Cr-Ni-Fe-Mo-Cu-Cb stabilized	N08020	B464/B464M, B468, B729	B463	B472, B473, B462
CR3127	WP3127	Low C-Ni-Fe-Cr-Mo-Cu	N08031	B619/B619M, B622, B626	B625	B564, B649, B462, B472
CRH120	WPH120	Ni-Cr-Fe	N08120	B407, B514, B515	B409	B408, B564
CR330	WP330	Ni-Fe-Cr-Si	N08330	B535, B710	B536	B511, B512
CR6XN	WP6XN	Fe-Ni-Cr-Mo-N	N08367	B675, B676, B690	B688	B472, B564, B691, B462
CRNIC	WPNIC	Ni-Fe-Cr	N08800	B407, B514, B515	B409	B408, B564
CRNIC10	WPNIC10	Ni-Fe-Cr	N08810	B407, B514, B515	B409	B408, B564
CRNIC11	WPNIC11	Ni-Fe-Cr	N08811	B407	B409	B408, B564
CRNICMC	WPNICMC	Ni-Fe-Cr-Mo-Cu	N08825	B423, B704, B705	B424	B425, B564
CR1925	WP1925	Low C-Ni-Fe-Cr-Mo-Cu	N08925	B673, B674, B677	B625	B649
CR1925N	WP1925N	Low C-Ni-Fe-Cr-Mo-Cu-N	N08926	B673, B674, B677	B625	B649
CR HB	WPHB	Ni-Mo	N10001	B619/B619M, B622, B626	B333	B335
CR HN	WPHN	Ni-Mo-Cr-Fe	N10003		B434	B573
CR H242	WPH242	Ni-Mo-Cr-Fe	N10242	B619/B619M, B622, B626	B434	B573, B564
CR HC 276	WPHC276	Low C-Ni-Mo-Cr	N10276	B619/B619M, B622, B626	B575	B574, B564, B462, B472
CRB10	WPB10	Low C-Ni-Mo-Cr-Fe	N10624	B619/B619M, B622, B626	B333	B335, B564
CRVB4	WPVB4	Ni-Mo	N10629	B619/B619M, B622, B626	B333	B335, B564, B462, B472
CR HB2	WPHB-2	Ni-Mo	N10665	B619/B619M, B622, B626	B333	B335, B564, B462, B472
CR HB3	WPHB-3	Ni-Mo	N10675	B619/B619M, B622, B626	B333	B335, B564, B462, B472
CRH160	WPH160	Ni-Co-Cr-Si	N12160	B619/B619M, B622, B626	B435	B564, B572
CR3033	WP3033	Low C-Cr-Ni-Fe-N	R20033	B619/B619M, B622, B626	B625	B564, B649, B472, B462
CRH556	WPH556	Ni-Fe-Cr-Co	R30556	B619/B619M, B622, B626	B435	B572

<sup>A</sup> When WP fittings are of welded construction or made from welded pipe, the symbol shall be supplemented with W or WX as applicable. If ultrasonic examination in accordance with 5.2.4.2 or 5.2.5.1 is used, the symbol shall be supplemented by WU or WXU as applicable.

<sup>B</sup> See 2.1 and 5.1.

<sup>C</sup> Yield strength shall be 25 000 psi (172 MPa) min, for all hot-formed, annealed fittings made from WPNC material.

5.2.2 Grade WP fittings ordered as Class S shall be of seamless construction and shall meet all requirements of ASME B16.9 or B16.11.

5.2.3 All classes of fittings shall have the welders, welding operators, and welding procedures qualified under the provisions of Section IX of the ASME Boiler and Pressure Vessel Code.

5.2.4 Grade WP fittings ordered as Class W shall meet the requirements of ASME B16.9 and shall have all pipe welds made by the starting material manufacturer or the fitting manufacturer with the addition of filler radiographically examined throughout the entire length in accordance with Paragraph UW-51 of Section VIII, Division 1, of the ASME Boiler and Pressure Vessel Code, except as exempt by 5.2.4.1, and 5.2.4.2.

5.2.4.1 The weld in the starting pipe, made to one of the pipe or tube product specifications listed in Table 2, shall not require radiography, provided that no filler metal is used in making the weld.

5.2.4.2 Instead of the radiographic examination, and at the option of the manufacturer, welds made by the fitting manufacturer may be ultrasonically examined in accordance with the Code requirements stated in 5.2.6.

5.2.5 Grade WP fittings ordered as Class WX shall meet the requirements of ASME B16.9 and shall have all welds, whether made by the fitting manufacturer or the starting material manufacturer, radiographically examined throughout their entire length in accordance with Paragraph UW-51 of Section VIII, Division 1, of the ASME Boiler and Pressure Vessel Code, except as exempt by 5.2.5.1. The radiography for this class of fittings may be done either prior to or after forming at the option of the manufacturer.

5.2.5.1 Instead of the radiographic examination, and at the option of the manufacturer, welds, whether made by the fitting manufacturer or the starting material manufacturer, may be ultrasonically examined in accordance with the Code requirements stated in 5.2.6.

5.2.6 Grade WP fittings ordered as Class WU shall meet the requirements of ASME B16.9 and shall have all welds, whether made by the fitting manufacturer or the starting material manufacturer, ultrasonically examined throughout their entire length in accordance with Appendix 12 of Section VIII, Division 1, of the ASME Boiler and Pressure Vessel Code. The ultrasonic examination of welds for this class may be performed either prior to or after forming at the option of the manufacturer.

5.2.7 Personnel performing NDE examinations shall be qualified in accordance with SNT-TC-1A.

5.2.8 Fittings covered in MSS SP-43, MSS SP-95, or MSS SP-97 and ordered as CR\*\*\* shall meet the requirements of MSS SP-43, MSS SP-95, or MSS SP-97, respectively, and do not require non-destructive examination.

5.2.9 All joints welded with filler metal shall be finished in accordance with the requirements of Paragraph UW-35 (a) of Section VIII, Division 1, of the ASME Boiler and Pressure Vessel Code.

5.2.10 Radiographic examination of the weld buildup on cold-formed stub ends shall not be required provided that all the following steps are adhered to:

5.2.10.1 The weld procedure and welders or welding operators meet the requirements of 5.2.3.

5.2.10.2 All weld surfaces are liquid penetrant examined in accordance with Appendix 8 of Section VIII, Division 1 of the ASME Boiler and Pressure Vessel Code.

5.2.10.3 Repair of areas in the weld is permitted, but 5.2.10.1 and 5.2.10.2 must be repeated.

5.2.10.4 Fittings shall be marked with the symbol WBU following the alloy designation (for example: WPN-WBU).

5.2.11 Stubends may be produced with the entire lap added as weld metal to a straight pipe section provided the welding satisfies the requirements of 5.2.3 for qualifications and 5.3 for heat treatment.

5.2.11.1 Grade **WP\*\*\*\*Class W** – Radiographic examination of the welds, made with the addition of filler metal, is required. See 5.2.4.

5.2.11.2 Grade **WP\*\*\*\*Class WX** – Radiographic examination of all welds, made with or without the addition of filler metal is required. See 5.2.5.

5.2.11.3 Grade **WP\*\*\*\*Class WU** – Ultrasonic examination of all welds, made with or without the addition of filler metal, is required. See 5.2.6.

5.2.11.4 Grade **CR** – Nondestructive examination is not required. See 5.2.8.

5.2.12 Stubends may be produced with the entire lap added by the welding of a ring, made from plate or flat bar of the same alloy grade and composition, to the outside of a straight section of pipe, provided the weld is a double welded full penetration joint and satisfies the requirements of 5.2.3 for qualifications and 5.3 for heat treatment.

5.2.12.1 Grade **WP\*\*\*\*Class W** – Radiographic examination of all welds, made with the addition of filler metal, is required. See 5.2.4.

5.2.12.2 Grade **WP\*\*\*\*Class WX** – Radiographic examination of all welds, made with or without the addition of filler metal, is required. See 5.2.5.

5.2.12.3 Grade **WP\*\*\*\*Class WU** – Ultrasonic examination of all welds, made with or without the addition of filler metal, is required. See 5.2.6.

5.2.12.4 Grade **CR** – Nondestructive examination is not required. See 5.2.8.

5.3 *Heat Treatment*—All fittings shall be furnished heat treated. See Table 3 for heat treatments. All forming or welding shall be done and completed prior to any final heat treatment.

## 6. Chemical Composition

6.1 The material shall conform to the requirements as to chemical composition for the respective material prescribed in Table 2.

6.2 Records of chemical analysis made in accordance with the applicable specification listed in Table 2 shall be certification that the material of the fitting meets the requirements of this specification.

TABLE 3 Heat Treatment

Corrosion-Resistant Fittings	ASME Pressure Fittings	Alloy	UNS Designation	Heat Treatment <sup>A,B</sup> DEG °F [°C]	Quench
CRN	WPN	Ni	N02200	1650-1700 [900-928]	Rapid Air/Water
CRNL	WPNL	Ni, Low C	N02201	1650-1700 [900-928]	Rapid Air/Water
CRNC <sup>C</sup>	WPNC <sup>C</sup>	Ni-Cu	N04400	1650-1700 [900-928]	Rapid Air/Water
CR HX	WPHX	Ni-Cr-Mo-Fe	N06002	2150 [1177] <sup>D</sup>	Rapid Air/Water
CR HG	WPHG	Ni-Cr-Fe-Mo-Cu	N06007	2100-2150 [1150-1177]	Rapid Air/Water
CR HC 22	WPHC22	Low C-Ni-Mo-Cr	N06022	2050 [1121] <sup>D</sup>	Rapid Air/Water
CRV602	WPH602	Ni-Cr-Fe	N06025	2160-2280 [1180-1250]	Rapid Air/Water
CR HG 30	WPHG30	Ni-Cr-Fe-Mo-Cu	N06030	2150 [1177] <sup>D</sup>	Rapid Air/Water
CRHG35	WPHG35	Ni-Cr-Mo	N06035	2050 [1121]	Rapid Air/Water
CR MC	WPHMC	Ni-Cr-Mo	N06044	2100-2230 [1150-1220]	Rapid Air/Water
CRV45TM	WPV45TM	Ni-Cr-Fe	N06045	2150 [1177]	Rapid Air/Water
CR5923	WP5923	Low C-Ni-Cr-Mo	N06059	2050 [1121]	Rapid Air/Water
CR HC 2000	WPHC2000	Low C-Ni-Cr-Mo-Cu	N06200	2075-2125 [1135-1163]	Rapid Air/Water
CRM21	WPM21	Low C-Ni-Cr-Mo-Ta	N06210	2150 [1177]	Rapid Air/Water
CRH230	WPH230	Ni-Cr-W-Mo	N06230	2150-2250 [1177-1232]	Rapid Air/Water
CRHBC1	WPHBC1	Low C-Ni-Mo-Cr	N10362	2100 <sup>E</sup> [1147]	Rapid Air/Water
CR HC 4	WPHC4	Low C-Ni-Mo-Cr	N06455	1950 [1065] <sup>D</sup>	Rapid Air/Water
CRNCI	WPNCI	Ni-Cr-Fe	N06600	1800-1850 [983-1010]	Rapid Air/Water
CR603GT	WP603GT	Ni-Cr-Fe-Al	N06603	2175 [1189]	Rapid Air/Water
CRNCMC	WPNCMC	Ni-Cr-Mo-Cb	N06625 Gr 1	1600 [871]	Rapid Air/Water
CRNCMC	WPNCMC	Ni-Cr-Mo-Cb	N06625 Gr 2	2000 [1093] <sup>D</sup>	Rapid Air/Water
CRIN686	WPIN686	Low C-Cr-Ni-Mo	N06686	2150 [1177]	Rapid Air/Water
CR626Si	WP626Si	Ni-Cr-Mo-Si	N06219	2050 [1121]	Rapid Air/Water
CR HG3	WPHG3	Ni-Cr-Fe-Mo-Cu	N06985	2100-2150 [1147-1177]	Rapid Air/Water
CR20CB	WP20CB	Cr-Ni-Fe-Mo-Cu-Cb stabilized	N08020	1700-1850 [927-1010]	Rapid Air/Water
CR3127	WP3127	Low C-Ni-Fe-Cr-Mo-Cu	N08031	2175 [1189]	Rapid Air/Water
CRH120	WPH120	Ni-Cr-Fe	N08120	2175-2225 [1189-1220]	Rapid Air/Water
CR330	WP330	Ni-Fe-Cr-Si	N08330	1900 [1038]	Rapid Air/Water
CR6XN	WP6XN	Fe-Ni-Cr-Mo-N	N08367	2025 [1107]	Rapid Air/Water
CRNIC	WPNIC	Ni-Fe-Cr	N08800	1800-1900 [983-1038] <sup>F</sup>	Rapid Air/Water
CRNIC10	WPNIC10	Ni-Fe-Cr	N08810	2100-2150 [1147-1177] <sup>F</sup>	Rapid Air/Water
CRNIC11	WPNIC11	Ni-Fe-Cr	N08811	2100-2150 [1147-1177] <sup>F</sup>	Rapid Air/Water
CRNICMC	WPNICMC	Ni-Fe-Cr-Mo-Cu	N08825	1700-1800 [930-983] <sup>F</sup>	Rapid Air/Water
CR1925	WP1925	Low C-Ni-Fe-Cr-Mo-Cu	N08925	1800-1900 [983-1038]	Rapid Air/Water
CR2120	WP2120	Low C-Ni-Cr-Mo	N06058	2075 [1135]	Rapid Air/Water
CR1925N	WP1925N	Low C-Ni-Fe-Cr-Mo-Cu-N	N08926	2150 [1177]	Rapid Air/Water
CRHB	WPHB	Ni-Mo	N10001	1950 [1065] <sup>D</sup>	Rapid Air/Water
CRHN	WPHN	Ni-Mo-Cr-Fe	N10003	2150 [1177] <sup>D</sup>	Rapid Air/Water
CR H242	WPH242	Ni-Mo-Cr-Fe	N10242	1925-2025 [1050-1105]	Rapid Air/Water
CR HC 276	WPHC276	Low C-Ni-Mo-Cr	N10276	2050 [1121] <sup>D</sup>	Rapid Air/Water
CRB10	WPB10	Low C-Ni-Mo-Cr-Fe	N10624	2050 [1121]	Rapid Air/Water
CRVB4	WPVB4	Ni-Mo	N10629	1975 [1080]	Rapid Air/Water
CR HB2	WPHB2	Ni-Mo	N10665	1950 [1065] <sup>D</sup>	Rapid Air/Water
CR HB3	WPHB3	Ni-Mo	N10675	1950 [1065] <sup>D</sup>	Rapid Air/Water
CRH160	WPH160	Ni-Co-Cr-Si	N12160	2025 [1107] <sup>D</sup>	Rapid Air/Water
CR3033	WP3033	Low C-Cr-Ni-Fe-N	R20033	2050 [1121]	Rapid Air/Water
CRH556	WPH556	Ni-Fe-Cr-Co	R30556	2150 [1177] <sup>D</sup>	Rapid Air/Water

<sup>A</sup> DELETED<sup>B</sup> Set temperature,  $\pm 25^{\circ}\text{F}$  [ $15^{\circ}\text{C}$ ].<sup>C</sup> Yield strength shall be 25 000 psi [172 MPa] min, for all hot-formed, annealed fittings made from WPNC material.<sup>D</sup> Minimum temperature.<sup>E</sup> DELETED<sup>F</sup> Heat treatment is highly dependent on intended service temperature – consult material manufacturer for specific heat treatments within the indicated range for end use temperature.

6.3 If a product (check) analysis is made by the purchaser, the material shall conform to the requirements for product (check) analysis prescribed for the respective product in Table 2 and Specification B880 for check analysis.

6.4 In fittings of welded construction, the alloy content of the deposited weld metal shall conform to that required of the base metal or for equivalent weld metal as given in the AWS Filler Metal Specification A5.11 and A5.14.

## 7. Mechanical Properties and Other Requirements

### 7.1 Tensile Requirements:

7.1.1 (All Table 2 alloys except for UNS N06625 Grade 1 or Grade 2).

7.1.1.1 Material used in the manufacture of the fittings shall conform to the requirements for tensile properties as prescribed for the respective product in Table 2.

7.1.1.2 Finished fittings shall conform to the properties for the respective material and temper as prescribed in the specifications referred to in Table 2. The properties of fittings made from forging stock of materials in Table 2 shall conform to either the properties of forgings in the respective forging specifications, or to other wrought product specifications listed in Table 2 of the respective material when forging specifications are not listed.

7.1.1.3 Tension tests of the finished fittings made from forging stock are required. For all other finished fittings, tension tests of the finished fittings are not required unless otherwise agreed upon between the manufacturer and the purchaser.

7.1.2 *Tensile Requirements* (For fittings made to meet the mechanical properties of UNS N06625 Grade 1):

7.1.2.1 At the option of the manufacturer, the material used in the manufacture of UNS N06625 Grade 1 fittings shall conform to the mechanical property requirements of either UNS N06625 Grade 1 or Grade 2 as prescribed for the respective product in Table 2.

7.1.2.2 Tension tests are required in accordance with 7.1.2.3.

7.1.2.3 Tension tests are required per lot (Note S2.3) per furnace charge. Tension specimens may be obtained from a fitting or a representative test piece (Note S2.2). Tension specimens representing fittings of welded construction, made with the addition of filler metal, are to include the weld and be prepared so that the weld is at the specimen's midlength location.

7.1.2.4 All finished fittings, including those made from forging stock, shall conform to the minimum UNS N06625 Grade 1 mechanical properties as prescribed for the respective starting raw material product listed in Table 2 except that fittings of welded construction are exempt from the tensile ductility requirement (elongation) and the yield strength requirements.

7.1.3 *Tensile Requirements* (For fittings made to meet the mechanical properties of UNS N06625 Grade 2):

7.1.3.1 At the option of the manufacturer, the material used in the manufacture of UNS N06625 Grade 2 fittings shall conform to the mechanical property requirements of either UNS N06625 Grade 1 or Grade 2 as prescribed for the respective product in Table 2.

7.1.3.2 Tension tests are not required provided the grade of starting raw material is designated as UNS N06625 Grade 2 in the raw material manufacturer's MTR description and the final heat treat temperature of the fittings is in compliance with the recommended solution annealing heat treat procedure for the grade. Tension tests are required if the grade of starting raw material is designated as UNS N06625 Grade 1 in the raw material manufacturer's MTR description.

7.1.3.3 Tension tests, if required, are to be performed per lot (Note S2.3) provided that all heat treatments are performed in furnaces controlled within a  $\pm 25^\circ\text{F}$  [ $15^\circ\text{C}$ ] range of set point

and are equipped with calibrated recording pyrometers so that all other subsequent heat treatments can be conducted within the same  $\pm 25^\circ\text{F}$  [ $15^\circ\text{C}$ ] temperature range as the furnace charge that contained the test specimen. Tension specimens may be obtained from a fitting or a representative test piece. In this paragraph only, a representative test piece is defined as a test specimen from the same heat of fitting raw material having approximately the same amount of working. In addition, the test piece representing fittings manufactured from bars, plate or forgings shall have a cross section equal to the greatest cross section of the fitting, a test piece representing fittings manufactured from pipe shall have an outside diameter and wall thickness equal to those of the fitting and a test piece for fittings of welded construction, made with the addition of filler metal, shall be prepared to the same welding procedures and from the same heat of material as the fittings it represents. Tension specimens representing fittings of welded construction, made with the addition of filler metal, are to include the weld and be prepared so that the weld is at the specimen's midlength location.

7.1.3.4 All finished fittings, including those made from forging stock, shall conform to the minimum UNS N06625 Grade 2 mechanical properties as prescribed for the representative starting raw material product listed in Table 2 except that fittings of welded construction are exempt from the tensile ductility requirement (elongation) and the yield strength requirements.

#### 7.2 *Hydrostatic Tests:*

7.2.1 Hydrostatic testing of wrought fittings is not required by this specification.

7.2.2 All fittings shall be capable of withstanding without failure, leakage, or impairment of their serviceability, a test pressure prescribed in the specifications for the pipe with which the fitting is recommended to be used.

## 8. Dimensions

8.1 Fittings or components produced in accordance with this specification shall have sizes, shapes, and dimensions in accordance with those specified in ASME B16.9, ASME B16.11, MSS SP-43, MSS SP-95, MSS SP-97.

## 9. Workmanship, Finish, and Appearance

9.1 The fittings shall be free of injurious defects and have a workmanlike finish. Minor defects may be removed by grinding, provided the wall thickness is not decreased to less than the allowable specification minimum and provided the grinding is smooth and leaves no shoulders.

9.2 The fittings shall be cleaned free of scale.

## 10. Inspection

10.1 Inspection of the material by the purchaser at the place of manufacture shall be made as agreed upon between the purchaser and the manufacturer as part of the purchase contract.

**TABLE 4 Product Marking Examples for Grades and Classes**

Grade and Class Marking	Description
CRN	Single grade: no classes in CR grades
CRN/NL	Multiple grades, meet chemical and mechanical properties of each
WPN-S	Single grade: seamless
WPN-W	Single grade: welded: RT or UT pipe welds with filler metal and all fitting manufacturer's welds
WPN-WX	Single grade: welded: RT all welds with or without filler metal
WPN-WU	Single grade: welded: UT all welds with or without filler metal
WPN/NL-S	Multiple grades: meet chemical and mechanical properties of each: seamless

## 11. Rejection and Rehearing

11.1 Material that fails to conform to the requirements of this specification may be rejected. Rejection should be reported to the producer or supplier promptly and in writing. In case of dissatisfaction with the results of the test, the producer or supplier may make claim for a rehearing.

## 12. Certifications

12.1 Test reports are required for all fittings covered by this specification. Each test report shall include the following information:

- 12.1.1 The year-date of the specification and class to which the fitting was furnished,
- 12.1.2 Heat numbers or serial number traceable to heat numbers,
- 12.1.3 Chemical analyses for all starting materials,
- 12.1.4 Mechanical properties for all starting materials, or actual mechanical properties if tension testing was required,
- 12.1.5 For construction with filler metal added, weld metal chemical analyses or AWS classification,
- 12.1.6 For welded stub ends, the construction method per 5.2.11 or 5.2.12 shall be stated,
- 12.1.7 Heat treatment per Table 3,
- 12.1.8 Results of all nondestructive examinations,

12.1.9 Results of all tests required by Supplementary Requirements and the order, and

12.1.10 Statement that the fitting was manufactured, sampled, tested and inspected in accordance with the specification and was found to meet the requirements.

## 13. Product Marking

13.1 The manufacturer's name or trademark, material, grade, if applicable, the size and schedule number, the designation as shown in Table 2, under "Marking," either column 1 for Grade CR fittings or column 2 for Grade WP fittings, shall be stamped, stenciled, or otherwise permanently marked on each fitting. Grade WP fitting marking also must include the suffix in accordance with 5.2. On wall thicknesses thinner than 0.083 in. [2.1 mm], no steel stamps or other indented markings shall be used. When the size does not permit complete marking, identification marks may be omitted in the sequence shown in MSS SP-25. See Table 4 for marking example of grades and classes.

NOTE 1—When steel stamps are used, the marking shall not be deep enough to cause cracks or to reduce the wall thickness of the fittings below the minimum allowed by the applicable specification.

## 14. Keywords

- 14.1 nickel alloy fittings

## SUPPLEMENTARY REQUIREMENTS

These requirements shall not be considered unless specified in the order, in which event the supplementary requirements specified shall be made at the place of manufacture, unless otherwise agreed upon.

### S1. Product Analysis (Note S2.1)

S1.1 A product analysis shall be made from each heat of base metal and, if of welded construction, from each lot (Note S2.3) number of welding material of the fittings offered for delivery. The analysis shall conform to the requirements specified in Section 6.

### S2. Tension Test (Note S2.1)

S2.1 One tension test shall be made on one fitting or representative test piece (Note S2.2) per lot (Note S2.3) of fittings. If the fittings are of welded construction, made with the addition of filler metal, the tension specimen shall include the weld and be prepared so that the weld is at the midlength

location of the specimen. However, in no case shall the tensile properties of the finished fittings be less than the requirements of the pipe specifications listed in Table 2, except that weld specimens are exempt from the tensile ductility requirements.

NOTE S2.1—If the results of any of the tests specified in Sections S1 or S2 do not conform to requirements, retests may be made at the manufacturer's expense on additional fittings or representative test pieces of double the original number from the same heat or lot as defined in Section S1 or S2. If either of the additional test pieces fails, the lot shall be rejected.

NOTE S2.2—*Representative Test Piece*: Where the test specimen for the tension test cannot be taken from a fitting due to size limitations, a representative test shall be obtained. The test piece shall be from the same heat and heat treated in the same batch or charge as the fittings it represents, and shall have approximately the same amount of working. In addition, test pieces representing fittings manufactured from bars, plate, or forgings shall have a cross section equal to the greatest cross section of the fitting, and test pieces representing fittings manufactured from pipe shall have an outside diameter and wall thickness equal to those of the fitting. The test piece for fittings of welded construction, made with the addition of filler metal, shall be prepared to the same weld procedures and from the same heats of material as the fittings it represents.

NOTE S2.3—A lot shall consist of all fittings of the same type, size, and wall thickness, manufactured from one heat of material, and, if welding is performed, using the same size and AWS classification welding product.

### S3. Liquid Penetrant Test

S3.1 All surfaces shall be liquid penetrant tested. The method shall be in accordance with Practice E165. Acceptance limits shall be as specified by the purchaser.

### S4. Hydrostatic Test

S4.1 A hydrostatic test shall be applied as agreed upon between the manufacturer and purchaser.

### S5. Bar Stock Fittings

S5.1 Fittings machined from solid bar stock are not permitted.

### S6. Positive Material Identification Examination

S6.1 Product shall receive Positive Material Identification to ensure that the purchaser is receiving product of the correct material grade prior to shipment of the product. This examination is a method to assure that no material grade mix-up has happened during manufacturing and marking of the product.

S6.2 Product shall receive a Positive Material Identification examination by Guide E1916.

S6.3 The quantity examined shall be 100 % of the product.

S6.4 All product that is not of the correct material grade shall be rejected.

S6.5 The method of product marking after examination shall be agreed upon between the manufacturer and purchaser.

# SPECIFICATION FOR TITANIUM AND TITANIUM ALLOY CASTINGS



**SB-367**

(Identical with ASTM Specification B367-13(2017) except Supplementary Requirements S5 for hot isostatic pressing (HIP) and S6 (Tension Test) are mandatory per new para. 6; and welders, welding operators, and welding procedures per revised para. 11.1 shall be in accordance with Section IX; revision of para. 11.2 requiring that filler metals, if used during repair, must conform to SFA-5.16/SFA-5.16M requirements.)

# Specification for Titanium and Titanium Alloy Castings

## 1. Scope

1.1 This specification covers titanium and titanium alloy castings intended for general corrosion resistant and industrial applications, as follows:

- 1.1.1 *Grade C-2*—UNS R52550. Unalloyed titanium,
- 1.1.2 *Grade C-3*—UNS R52550. Unalloyed titanium,
- 1.1.3 *Grade C-5*—UNS R56400. Titanium alloy (6 % aluminum, 4 % vanadium),
- 1.1.4 *Grade C-7*—UNS R52700. Unalloyed titanium plus 0.12 to 0.25 % palladium,
- 1.1.5 *Grade C-8*—UNS R52700. Unalloyed titanium plus 0.12 to 0.25 % palladium,
- 1.1.6 *Grade C-9*—UNS R56320. Titanium alloy (3 % aluminum, 2.5 % vanadium),
- 1.1.7 *Grade C-12*—UNS R53400. Titanium alloy (0.3 % molybdenum, 0.8 % nickel),
- 1.1.8 *Grade C-16*—UNS R52402. Unalloyed titanium plus 0.04 to 0.08 % palladium,
- 1.1.9 *Grade C-17*—UNS R52252. Unalloyed titanium plus 0.04 to 0.08 % palladium, and
- 1.1.10 *Grade C-38*—UNS R54250. Titanium alloy (4 % aluminum, 2.5 % vanadium, 1.5 % iron).

1.2 This specification is intended for use of purchasers and/or producers of reactive metal castings for defining the requirements and assuring the properties of castings for unique corrosion-resistant applications, that is, not for commodity items which must meet all potential purchasers' requirements.

1.2.1 Users are advised to use the specification as a basis for obtaining castings which will meet minimum acceptance requirements established and revised by consensus of the members of the committee.

1.2.2 User requirements considered more stringent may be met by the addition to the purchase order of one or more supplementary requirements, which may include, but are not limited to, those listed in Sections S1 through S8.

1.3 The values stated in inch-pound units are to be regarded as standard. The values given in parentheses are mathematical conversions to SI units that are provided for information only and are not considered standard.

1.4 *This international standard was developed in accordance with internationally recognized principles on standardization established in the Decision on Principles for the Development of International Standards, Guides and Recommendations issued by the World Trade Organization Technical Barriers to Trade (TBT) Committee.*

## 2. Referenced Documents

- 2.1 *ASTM Standards:*
  - A802/A802M Practice for Steel Castings, Surface Acceptance Standards, Visual Examination
  - E8 Test Methods for Tension Testing of Metallic Materials
  - E10 Test Method for Brinell Hardness of Metallic Materials
  - E18 Test Methods for Rockwell Hardness of Metallic Materials
  - E29 Practice for Using Significant Digits in Test Data to Determine Conformance with Specifications
  - E94 Guide for Radiographic Examination Using Industrial Radiographic Film
  - E142 Method for Controlling Quality of Radiographic Testing (Withdrawn 2000)
  - E165 Practice for Liquid Penetrant Examination for General Industry
  - E446 Reference Radiographs for Steel Castings Up to 2 in. (50.8 mm) in Thickness
  - E539 Test Method for Analysis of Titanium Alloys by X-Ray Fluorescence Spectrometry
  - E1409 Test Method for Determination of Oxygen and Nitrogen in Titanium and Titanium Alloys by Inert Gas Fusion
  - E1447 Test Method for Determination of Hydrogen in Titanium and Titanium Alloys by Inert Gas Fusion Thermal Conductivity/Infrared Detection Method

E1941 Test Method for Determination of Carbon in Refractory and Reactive Metals and Their Alloys by Combustion Analysis

E2371 Test Method for Analysis of Titanium and Titanium Alloys by Direct Current Plasma and Inductively Coupled Plasma Atomic Emission Spectrometry (Performance-Based Test Methodology)

E2626 Guide for Spectrometric Analysis of Reactive and Refractory Metals (Withdrawn 2017)

### 3. Terminology

3.1 *Definitions of Terms Specific to This Standard:*

3.1.1 *lot, n*—shall consist of all castings of the same design produced from the same pour.

3.1.2 *pour, n*—shall consist of all material melted and cast at one time.

### 4. Ordering Information

4.1 Orders for castings to this specification shall include the following as required, to describe the requirements adequately:

4.1.1 Description of the castings by pattern number or drawing. Dimensional tolerances shall be included on the casting drawing,

4.1.2 Quantity,

4.1.3 Grade designation (see Table 1),

4.1.4 Options in the specification, and

4.1.5 Supplementary requirements desired, including the standards of acceptance.

### 5. Materials and Manufacture

5.1 Materials for this specification shall be melted by conventional processes used for reactive metals. Typical methods include the consumable electrode and induction-slag, plasma arc, induction-skull, and electron beam melting processes.

### 6. Mechanical Requirements

6.1 Mechanical Testing—Supplementary Requirement S6 is mandatory.

### 7. Chemical Composition

7.1 *Pour Analysis*—An analysis of each pour shall be made by the producer from a sample such as a casting or test bar that is representative of the pour. The chemical composition determined shall conform to the requirements specified for the relevant grade in Table 1.

7.1.1 The elements listed in Table 1 are intentional alloy additions or elements which are inherent to the manufacture of titanium sponge, ingot or mill product.

7.1.1.1 Elements other than those listed in Table 1 are deemed to be capable of occurring in the grades listed in Table 1 by and only by way of unregulated or unanalyzed scrap additions to the ingot melt. Therefore product analysis for elements not listed in Table 1 shall not be required unless specified and shall be considered to be in excess of the intent of this specification.

7.1.2 Elements intentionally added to the melt must be identified, analyzed, and reported in the chemical analysis.

7.2 When agreed upon by the producer and the purchaser and requested by the purchaser in his written purchase order, chemical analysis shall be completed for specific residual elements not listed in this specification.

7.3 *Product Analysis*—Product analysis tolerances do not broaden the specified heat analysis requirements, but cover variations between laboratories in the measurement of chemical content. The producer shall not ship material which is outside the limits specified in Table 1 for the applicable grade. Product analysis limits shall be as specified in Table 2.

7.4 *Sampling*—Samples for chemical analysis may be made by the purchaser on a representative casting from any lot. Due to the possibility of oxygen or other interstitial contamination, samples for oxygen, carbon, hydrogen, and nitrogen analysis shall be taken no closer than ¼ in. (6.3 mm) to a cast surface except that castings too thin for this shall be analyzed on representative material. The chemical composition determined shall conform to the analysis in Table 1 within the check analysis variations shown in Table 2 or shall be subject to rejection by the purchaser.

### 8. Heat Treatment

8.1 Unless otherwise specified in the contract, all castings will be supplied in the as-cast condition except when post-weld heat treatment is required.

8.2 If post-weld heat treatment is required, it shall consist of a stress relief performed at  $1075 \pm 25^\circ\text{F}$  ( $580 \pm 14^\circ\text{C}$ ) for Grades C-2, C-3, C-7, C-8, C-12, C-16 and C-17, and  $1200 \pm 25^\circ\text{F}$  ( $650 \pm 14^\circ\text{C}$ ) for Grades C-5, C-6, C-9, C-18, and C-38. Time at temperature shall be a minimum of ½ h plus an additional ½ h at temperature per inch of thickness for section sizes greater than 1 in. (25 mm). After heat treatment, the castings should be cooled in air or in the furnace to ambient temperature unless otherwise agreed upon between the purchaser and producer.

### 9. Methods of Chemical Analysis

9.1 The chemical analysis shall normally be conducted using the ASTM standard test methods referenced in 2.1. Other industry standard methods may be used where the ASTM test methods in 2.1 do not adequately cover the elements in the material or by agreement between the producer and purchaser. Alternate techniques are discussed in Guide E2626.

### 10. Workmanship, Finish, and Appearance

10.1 All castings shall be made in a workman-like manner and shall conform to the dimensions in drawings furnished by the purchaser before manufacturing is started. If the pattern is supplied by the purchaser, the dimensions of the casting shall be as predicted by the pattern.

10.2 The surface of the casting shall be free of adhering mold material, scale, cracks, and hot tears as determined by visual examination. Other surface discontinuities shall meet the visual acceptance standards specified in the order. Practice A802/A802M or other visual standards may be used to define acceptable surface discontinuities and finish. Unacceptable surface discontinuities shall be removed and their removal verified by visual examination of the resultant cavities.

**TABLE 1 Chemical Requirements**

Composition, Weight Percent<sup>A,B,C,D,E</sup>

Grade	UNS Carbon Number	Oxygen range or max.	Nitrogen max.	Hydrogen max.	Iron range or max.	Aluminum	Vanadium	Palladium	Ruthenium	Nickel	Molybdenum	Chromium	Cobalt	Zirconium	Niobium	Tin	Silicon	Other Elements, max. each	Other Elements, max. total
C-2	R52550	0.10	0.40	0.05	0.015	0.20	--	--	--	--	--	--	--	--	--	--	--	0.1	0.4
C-3	R52550	0.10	0.40	0.05	0.015	0.25	--	--	--	--	--	--	--	--	--	--	--	0.1	0.4
C-5	R56400	0.10	0.25	0.05	0.015	0.40	5.5-6.75	3.5-4.5	--	--	--	--	--	--	--	--	--	0.1	0.4
C-6	R54520	0.10	0.20	0.05	0.015	0.50	4.0-6.0	--	--	--	--	--	--	--	--	2.0-3.0	--	0.1	0.4
C-7	R52700	0.10	0.40	0.05	0.015	0.20	--	0.12-0.25	--	--	--	--	--	--	--	--	--	0.1	0.4
C-8	R52700	0.10	0.40	0.05	0.015	0.25	--	0.12-0.25	--	--	--	--	--	--	--	--	--	--	--
C-9	R56320	0.10	0.20	0.05	0.015	0.25	2.5-3.5	2.0-3.0	--	--	--	--	--	--	--	--	--	--	--
C-12	R53400	0.10	0.25	0.05	0.015	0.30	--	--	--	0.6-0.9	0.2-0.4	--	--	--	--	--	--	0.1	0.4
C-16	R52402	0.10	0.18	0.03	0.015	0.30	--	0.04-0.08	--	--	--	--	--	--	--	--	--	0.1	0.4
C-17	R52252	0.10	0.20	0.03	0.015	0.25	--	0.04-0.08	--	--	--	--	--	--	--	--	--	0.1	0.4
C-18	R58465	0.08	0.20	0.03	0.015	0.25	2.5-3.5	2.0-3.0	0.04-0.08	--	--	--	--	--	--	--	--	0.1	0.4
C-38	R54250	0.08	0.20-0.30	0.03	0.015	1.2-1.8	3.5-4.5	2.0-3.0	--	--	--	--	--	--	--	--	--	0.1	0.4

<sup>A</sup> At minimum, one pour analysis shall be completed and reported for all elements listed for the respective grade in this table.  
<sup>B</sup> If the casting is subjected to thermal or chemical processing following the pour, final product hydrogen shall be reported in lieu of pour hydrogen. Lower hydrogen may be obtained by negotiation with the manufacturer.  
<sup>C</sup> Single values are maximum. The percentage of titanium is determined by difference.  
<sup>D</sup> Other elements need not be reported unless the concentration level is greater than 0.1 % each, or 0.4 % total. Other elements may not be added intentionally. Other elements may be present in titanium or titanium alloys in small quantities and are inherent to the manufacturing process. In titanium these elements typically include aluminum, vanadium, tin, chromium, molybdenum, niobium, zirconium, hafnium, bismuth, ruthenium, palladium, yttrium, copper, silicon, cobalt, tantalum, nickel, boron, manganese, and tungsten.  
<sup>E</sup> The purchaser may, in the written purchase order, request analysis for specific elements not listed in this specification.

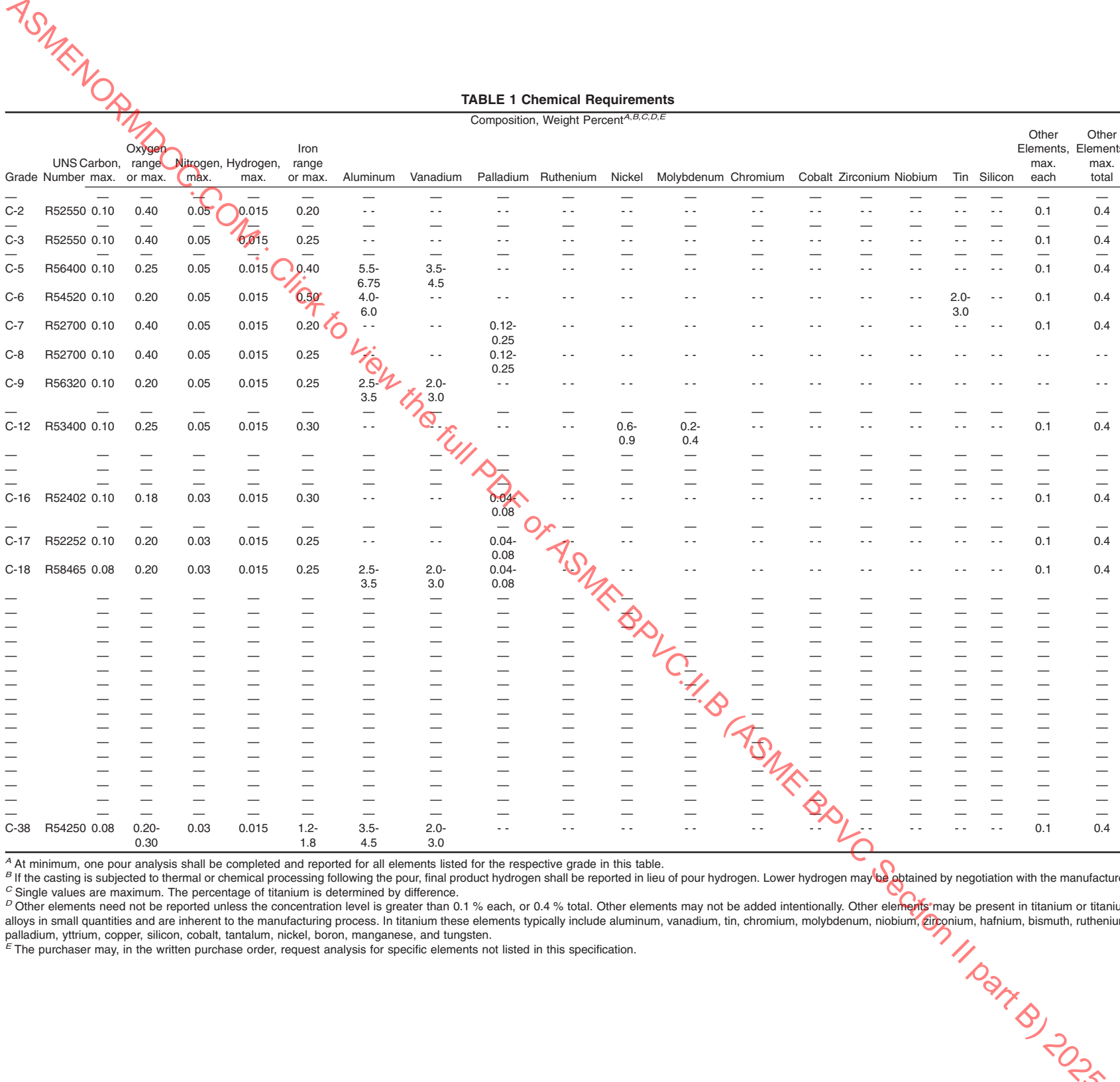

TABLE 2 Check Analysis Tolerances

Element	Maximum or Range, Weight %	Permissible Variation in Check Analysis
Nitrogen	0.05	+0.02
Carbon	0.10	+0.02
Hydrogen	0.015	+0.003
Iron	1.2–1.8	±0.20
	0.50	+0.15
	0.40	+0.08
	0.25	+0.05
	0.20	+0.04
Oxygen	0.25	+0.05
	0.20	+0.04
Aluminum	2.5–6.75	±0.40
Vanadium	2.0–4.5	±0.15
Tin	2.0–3.0	±0.15
Palladium	0.04–0.25	±0.02
Molybdenum	0.2–0.4	±0.04
Nickel	0.3–0.9	±0.05
Other (each)	0.10	+0.02

### 11. Repair by Welding

11.1 All welding, including repairs, shall be made using welders, welding operators, and welding procedures qualified in accordance with Section IX of the ASME Boiler and Pressure Vessel Code and certified to the quality requirements established by the producer. The procedures developed shall be consistent with standard practices recommended for reactive metal alloys. The producer shall maintain documentation on procedure and welder qualifications. Procedure modifications or special arrangements shall be as agreed upon between the producer and purchaser.

11.2 The composition of the deposited weld metal shall be within the chemical requirements for each grade established in Table 1. Filler metals, if used for weld repair, must conform to those metal compositions as shown in ASME SFA-5.16/SFA-5.16M (Specifications for Titanium and Titanium-Alloy Welding Electrodes and Rods).

11.2.1 Unalloyed titanium Grades C-2 and C-3, and low-alloy Grades C-12, C-7, C-8, C-16, and C-17 castings shall be stress-relieved if the repair is considered capable of adding stresses that will interfere with the purpose for which the castings are intended. The decision for stress relieving shall be made by the producer, unless otherwise agreed upon. The stress-relief cycle shall be in accordance with 8.2 followed by air or furnace cooling to room temperature, or as agreed upon between the purchaser and the producer.

11.2.2 Grade C-5 (Ti-6Al-4V), Grade C-6 (Ti-5Al-2.5Sn), Grade C-9, Grade C-18, and C-38 castings shall be stress-relieved after weld repair, if the weld defect or excavation is through a wall or exceeds 1 in.<sup>3</sup> (16.4 cm<sup>3</sup>) of deposited metal. All welds on Grade C-12 (Ti-3Mo-8Ni) castings shall be stress-relieved after weld repair. The stress-relief cycle shall be in accordance with 8.2.

11.2.3 Hot isostatic pressing (HIP) may be substituted for required thermal treatment provided all requirements for that treatment are met, and temperatures detrimental to the material properties are not reached.

### 12. Referee Test and Analysis

12.1 In the event of disagreement between the manufacturer and the purchaser on the conformance of the material to the requirements of this specification, a mutually acceptable referee shall perform the tests in question using the ASTM standard methods in 2.1. The referee's testing shall be used in determining conformance of the material to this specification.

### 13. Inspection

13.1 The producer shall afford the purchaser's inspector all reasonable facilities necessary to satisfy him that the material is being produced and furnished in accordance with this specification. Foundry inspection by the purchaser shall not interfere unnecessarily with the producer's operations.

13.2 If the results of any chemical or mechanical property test lot are not in conformance with the requirements of this specification, the lot may be retested at the option of the producer. The frequency of the retest will double the initial number of tests. If the results of the retest conform to the specification, then the retest values will become the test values for certification. Only original conforming test results or the conforming retest results shall be reported to the purchaser. If the results for the retest fail to conform to the specification, the material will be rejected in accordance with Section 14.

13.3 For purposes of determining conformance with the specifications contained herein, an observed or a calculated value shall be rounded off to the nearest unit in the last right-hand significant digit used in expressing the limiting value. This is in accordance with the round-off method of Practice E29.

### 14. Rejection

14.1 Any rejection based on test reports shall be reported to the producer within 60 days from the receipt of the test reports

14.2 Material that shows unacceptable discontinuities as determined by the acceptance standards specified on the order, subsequent to acceptance at the producer's works, may be rejected, and the producer shall be notified within 60 days, or as otherwise agreed upon.

14.3 In the event of disagreement between the producer and the purchaser on the conformance of the material to the requirements of this specification, a mutually acceptable referee shall perform the tests in question. The referee's testing shall be used in determining the conformance of the material to this specification.

### 15. Certification

15.1 The manufacturer shall supply at least one copy of the report certifying that the material supplied has been manufactured, inspected, sampled, and tested in accordance with the requirements of this specification and that the results of chemical analysis, tensile, and other tests meet the requirements of this specification for the grade specified. The report shall include results of all chemical analysis, tensile tests, and all other tests required by the specification.

### 16. Product Marking

16.1 Unless otherwise specified, the following shall apply.

16.1.1 Castings shall be marked for material identification with the ASTM designation number (Specification B367) and grade symbol, that is, C-2, C-3, C-5, C-6, C-7, C-8, C-9, C-12, C-16, C-17, C-18, or C-38 if size permits. Marking shall be in such position as not to impair the function of the casting.

16.1.2 The producer’s name or identification mark and the pattern number shall be cast or stamped using low stress stamps on all castings. Small size castings may be such that marking must be limited consistent with the available area.

16.1.3 The marking of lot numbers on individual castings shall be agreed upon by the producer and the purchaser.

16.1.4 Marking shall be in such a position as not to injure the usefulness of the casting.

**17. Keywords**

17.1 castings; corrosion resistant; titanium; titanium alloys

**SUPPLEMENTARY REQUIREMENTS**

Supplementary requirements shall be applied only when specified by the purchaser. Details of the supplementary requirements shall be agreed upon by the producer and purchaser. The specified tests shall be performed by the producer prior to shipment of the castings.

**S1. Radiographic Examination**

S1.1 When specified in the purchase order, castings shall be examined for internal discontinuities by means of X rays or gamma rays. Inspection procedure shall be in accordance with the Guide E94 and Test Method E142. Types and degrees of discontinuities considered shall be judged by the Reference Radiographs E446. Extent of examination and the basis for acceptance shall be agreed upon by the producer and the purchaser. A specification that may be used as a basis for such agreement is described as follows.

S1.2 *Extent of Examination:*

S1.2.1 *Category I*—The castings shall be 100 % inspected radiographically and film sent or made available for purchaser examination.

S1.2.2 *Category II*—Critical areas of all castings shall be radiographically inspected to ensure that casting quality is sufficient to meet customer needs. The film record need not be maintained.

S1.2.3 *Category III*—Sample castings shall be radiographed in accordance with an agreed upon schedule. When discontinuities exceed the acceptance limits, all castings in the lot shall be examined according to Category II.

S1.3 *Basis for Acceptance:*

S1.3.1 The maximum severity level for each specific type of discontinuity shall be agreed upon by the purchaser and producer. A specification which may be used as a basis for such agreement, using Reference Radiographs E446 is described as follows:

Category A	gas porosity	severity level 2
Category B	sand and slag inclusions	severity level 2
Category C	shrinkage CA	severity level 2
Category C	shrinkage CB	severity level 2
Category C	shrinkage CC	severity level 2
Category C	shrinkage CD	severity level 2
Category D	crack	none permitted
Category E	hot tear	none permitted
Category F	insert	none permitted

**S2. Liquid Penetrant Examination**

S2.1 The castings shall be examined for surface discontinuities by means of liquid penetrant examination. The examination shall be in accordance with Test Method E165. Areas to be inspected, methods and types of liquid penetrants to be used, developing procedure, and basis for acceptance shall be agreed upon between the producer and the purchaser.

**S3. Examination of Weld Preparation**

S3.1 Cavities prepared for welding due to surface discontinuities, such as cracks, open porosity, etc. shall be examined by means of liquid penetrant examination in order to verify removal of such discontinuities.

S3.2 Weld repairs that are made to eliminate discontinuities that are detected by radiography shall be re-radiographed to verify that unacceptable discontinuities have been removed.

**S5. Hot Isostatic Pressing (HIP)**

S5.1 Hot isostatic pressing (HIP) shall be used to improve as-cast quality when required. Temperature, time at temperature, and atmosphere shall be as agreed upon between the producer and the purchaser.

S5.2 Castings for which HIP is not required may be hot isostatic pressed by the producer in accordance with the requirements of 7.2.

S5.3 HIP may be substituted for required thermal treatment provided all requirements for that treatment are met and temperatures detrimental to the material properties are not reached.

**S6. Tension Test**

S6.1 Tensile properties shall be determined on material representing each pour. Properties shall be determined in the as-cast condition unless otherwise specified in the purchase order. The results shall conform to the requirements specified in Table S6-1.

**TABLE S6-1 Tensile Requirements**

Grade	Tensile Strength, min, ksi (MPa)	Yield Strength 0.2 % Offset, min, ksi (MPa)	Elongation in 1-in. Gage Length, min, %
C-2	50 (345)	40 (275)	15
C-3	65 (450)	55 (380)	12
C-5	130 (895)	120 (825)	6
C-6	115 (795)	105 (725)	8
C-7	50 (345)	40 (275)	15
C-8	65 (450)	55 (380)	12
C-9	90 (620)	70 (483)	10
C-12	70 (483)	50 (345)	8
C-16	50 (345)	40 (275)	15
C-17	35 (240)	25 (170)	20
C-18	90 (620)	70 (483)	10
C-38	130 (895)	115 (794)	8

**TABLE S8-1 Hardness Requirements**

Grade	Brinell Hardness, max <sup>A</sup>	Rockwell Hardness, max <sup>A</sup>
C-2	210	B96
C-3	235	C24
C-5	365	C39
C-6	335	C36
C-7	210	B96
C-8	235	C24
C-9	365	C39
C-12	235	C24
C-16	210	B96
C-17	235	C24
C-18	365	C39
C-38	365	C39

<sup>A</sup> Average of three tests.

S6.2 Test bars may be obtained from special test blocks cast for that purpose or cut from castings processed with a lot.

S6.3 Tensile tests shall be made in accordance with the requirements of Test Methods E8. Tensile properties shall be determined using a strain rate of 0.003 to 0.007 in./in./min (0.003 to 0.007 mm/mm/min) through the yield strength.

S6.4 If any test specimen shows defective machining or develops flaws, it may be discarded and another specimen substituted from the same pour.

### S7. Prior Approval of Major Weld Repairs

S7.1 Major weld repairs as defined and agreed upon between the producer and the purchaser shall be subject to the prior approval of the purchaser.

### S8. Hardness Test

S8.1 Hardness shall be determined on material representing each lot. Hardness shall be determined in the as-cast condition unless otherwise specified in the purchase order. The results shall conform to the requirements specified in Table S8-1.

S8.2 Hardness shall be determined on a sample cast for that purpose, or on a casting randomly selected from a lot. If a casting is used for a hardness sample, indentations shall be made in a surface that will not be subsequently machined. Hardness values reported shall be representative of the base metal of the castings and not of any surface contamination due to mold-metal interactions.

S8.3 Hardness tests shall be made in accordance with the requirements of Test Methods E10 or E18.

ASMENORMDOC.COM : Click to view the full PDF of ASME BPVC.II.B (ASME BPVC Section II part B) 2025

INTENTIONALLY LEFT BLANK

# SPECIFICATION FOR COPPER-NICKEL ALLOY CASTINGS



**SB-369**

(Identical with ASTM Specification B369-09(2016) except that certification and a test report have been made mandatory.)

ASMENORMDOC.COM : Click to view the full PDF of ASME BPVC.II.B (ASME BPVC Section II part B) 2025

# Specification for Copper-Nickel Alloy Castings

## 1. Scope

1.1 This specification establishes the requirements for copper-nickel alloy castings with nominal compositions shown in Table 1. These are as follows:

Copper Alloy UNS No.	Previous Designation
C96200	Alloy A
C96400	Alloy B

1.2 Castings of these alloys are used primarily for corrosion-resistance applications such as in construction and for pressure vessels, particularly in marine pumps, valves, and fittings.

1.3 These alloys are considered weldable, but they may be ordered with a weld test to ensure weldability. When extensive welding is to be performed on the casting, weldability tests should be specified in the ordering information (5.2.6) to ensure proper welding characteristics.

1.4 *Units*—The values stated in inch-pound units are to be regarded as standard. The values given in parentheses are mathematical conversions to SI units that are provided for information only and are not considered standard.

1.5 The following hazard statement applies only to Section 8, Weldability Test, of this specification. *This standard does not purport to address all of the safety concerns, if any, associated with its use. It is the responsibility of the user of this standard to establish appropriate safety and health practices and determine the applicability of regulatory limitations prior to use.*

## 2. Referenced Documents

### 2.1 ASTM Standards:

- B208 Practice for Preparing Tension Test Specimens for Copper Alloy Sand, Permanent Mold, Centrifugal, and Continuous Castings
- B824 Specification for General Requirements for Copper Alloy Castings
- B846 Terminology for Copper and Copper Alloys
- E527 Practice for Numbering Metals and Alloys in the Unified Numbering System (UNS)

### 2.2 ASME Code:

- ASME Boiler and Pressure Vessel Code

### 2.3 AWS Standard:

- AWS A5.6 Specification for Copper and Copper-Alloy Arc-Welding Electrodes

## 3. General Requirements

3.1 The following sections of Specification B824 form a part of this specification. In the event of a conflict between this specification and Specification B824, the requirements of this specification shall take precedence.

- 3.1.1 Terminology (Section 3),
- 3.1.2 Other Requirements (Section 7),
- 3.1.3 Dimensions, Mass, and Permissible Variations (Section 8),
- 3.1.4 Workmanship, Finish, and Appearance (Section 9),
- 3.1.5 Sampling (Section 10),
- 3.1.6 Number of Tests and Retests (Section 11),
- 3.1.7 Specimen Preparation (Section 12),
- 3.1.8 Test Methods (Section 13),
- 3.1.9 Significance of Numerical Limits (Section 14),

TABLE 1 Nominal Compositions

Copper Alloy UNS No.	Composition, %					
	Copper	Nickel	Iron	Silicon	Manganese	Niobium
C96200	87.5	10.0	1.5	0.1	0.9	...
C96400	67.0	30.0	0.7	0.5	0.8	1.0

- 3.1.10 Inspection (Section 15),
- 3.1.11 Rejection and Rehearing (Section 16),
- 3.1.12 Certification (Section 17),
- 3.1.13 Test Report (Section 18),
- 3.1.14 Product Marking (Section 19), and
- 3.1.15 Packaging and Package Marking (Section 20).

#### 4. Terminology

4.1 For definitions of terms relating to copper alloys, refer to Terminology B846.

#### 5. Ordering Information

5.1 Orders for castings under this specification should include the following information:

- 5.1.1 Specification title, number, and year of issue;
- 5.1.2 Quantity of castings;
- 5.1.3 Copper Alloy UNS Number (Table 2);
- 5.1.4 Pattern or drawing number and condition (as-cast, machined, and so forth);
- 5.1.5 ASME Boiler and Pressure Vessel Code Requirements (Section 12); and
- 5.1.6 When material is purchased for agencies of the U.S. Government, the Supplementary Requirements of this specification may be specified.

5.2 The following are optional and should be specified in the purchase order when required:

- 5.2.1 Pressure test or soundness requirements (Specification B824);
- 5.2.2 Witness inspection (Specification B824);
- 5.2.3 DELETED
- 5.2.4 DELETED
- 5.2.5 Product marking (Specification B824);
- 5.2.6 Weldability test (1.3, Section 8, and Table 2); and
- 5.2.7 Approval of weld procedure and records of repairs (Section 9).

TABLE 2 Chemical Requirements

	Copper Alloy UNS No. C96200		Copper Alloy UNS No. C96400	
	Min, %	Max, %	Min, %	Max, %
Copper	balance		balance	
Lead	...	0.01	...	0.01
Iron	1.0	1.8	0.25	1.5
Nickel, incl cobalt	9.0	11.0	28.0	32.0
Manganese	...	1.5	...	1.5
Silicon	...	0.50	...	0.50
Niobium	...	1.0 <sup>A</sup>	0.50	1.5
Phosphorus	...	0.02	...	0.02
Sulfur	...	0.02	...	0.02
Carbon	...	0.10	...	0.15

<sup>A</sup> When product or casting is intended for subsequent welding applications, and so specified by the purchaser, the niobium content shall be 0.40 % max.

#### 6. Chemical Composition

6.1 The castings shall conform to the chemical requirements shown in Table 2 for the copper alloy UNS numbers specified in the purchase order.

6.2 These specification limits do not preclude the presence of other elements. Limits may be established and analysis required for unnamed elements agreed upon between the manufacturer or supplier and the purchaser. Copper may be given as remainder and may be taken as the difference between the sum of all elements analyzed and 100 %. When all the elements in the table are analyzed, their sum shall be 99.5 % minimum.

#### 7. Mechanical Properties

7.1 Mechanical properties shall be determined from separately cast test bar castings, and shall meet the requirements shown in Table 3.

#### 8. Weldability Test

8.1 When specified in the purchase order at least one test cast as shown in Fig. 1 shall be prepared for each lot of welding grade castings (5.2.6).

8.2 The block shall be molded, gated, and risered in such a manner to produce a sound casting without defects that might interfere with welding or the interpretation of the results of the test.

8.3 The groove in the test block shall be completely filled with weld deposit metal, using the manual metallic-arc process with 1/8-in. (12.7-mm) or 5/32-in. (3.97-mm) diameter copper-nickel (70-30) coated electrodes conforming to classification AWS ECuNi of AWS Specification A5.6. The interpass temperature need not be controlled, unless it is to be controlled in fabrication.

8.4 One 3/8-in. (9.52-mm) minimum thick bend coupon (see Fig. 2), shall be removed longitudinally from the center of the welded block by machining, sawing, abrasive cutting, or other suitable means. Cut surfaces and edges should be sanded smooth if necessary. The side bend specimen then shall be bent 180° in a guided bend jig around a mandrel 1 1/2 in. (38.1 mm) in diameter with the weld located at the center of the bend.

TABLE 3 Mechanical Requirements

	Copper Alloy UNS No. C96200	Copper Alloy UNS No. C96400
Tensile strength, min, ksi <sup>A</sup> (MPa)	45 (310)	60 (415)
Yield strength, <sup>B</sup> min, ksi <sup>A</sup> (MPa)	25 (170)	32 (220)
Elongation in 2 in. (50.8 mm), %	20	20

<sup>A</sup> ksi = 1000 psi.

<sup>B</sup> Yield strength shall be determined as the stress producing an elongation under load of 0.5 %, that is 0.01 in. (0.254 mm) in a gage length of 2 in. (50.8 mm).

TABLE 4 Metric Conversion Values for Figs. 1 and 2

in.	(mm)	in.	(mm)
1/8	(3.18)	1 3/4	(44.4)
3/8	(9.52)	2 3/4	(69.8)
3/4	(19.0)	3	(76.2)
1	(25.4)	3 1/2	(88.9)
1 1/8	(28.6)	6	(152)

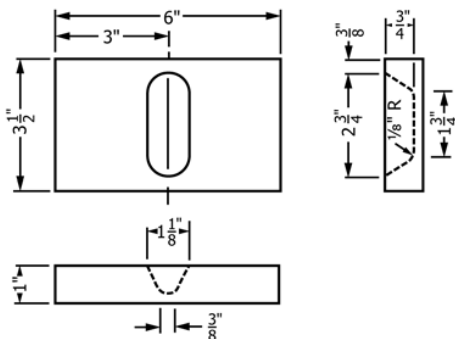

NOTE 1—For metric equivalents see Table 4.

FIG. 1 Cast Block for Weldability Test

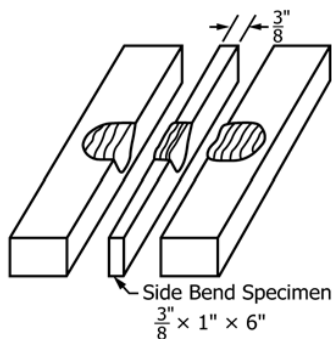

NOTE 1—For metric equivalents see Table 4.

FIG. 2 Weldability Test Block

8.5 Cracks or other open defects exceeding 1/8 in. (3.2 mm) measured in any direction in the fusion zone or heat-affected zone on the convex surface of the specimen after bending shall be cause for rejection. Cracks originating at weld-bead undercuts, at weld-slag inclusions, or at casting defects shall not be cause for rejection.

## 9. Casting Repair

9.1 Alloys included in this specification are generally weldable. Weld repairs may be made at the manufacturer's discretion provided each excavation does not exceed 20 % of the casting section or wall thickness or 4 % of the casting surface area.

9.2 Excavations that exceed those described in 9.1 may be made at the manufacturer's discretion except that when specified in the purchase order (5.2.7) the weld procedure shall be approved by the purchaser and the following record shall be maintained:

9.2.1 A sketch or drawing showing the dimensions, depth, and location of excavations;

9.2.2 Post weld heat treatment, when applicable;

9.2.3 Weld repair inspection results;

9.2.4 Casting identification number;

9.2.5 Weld procedure identification number;

9.2.6 Welder identification; and

9.2.7 Name of inspector.

9.3 The castings shall not be impregnated without approval of the purchaser.

## 10. Sampling

10.1 Test bar castings for tension testing of the copper alloy UNS numbers in this specification shall be cast to the form and dimensions shown in Fig. 1 or Fig. 2 of Practice B208.

## 11. Test Methods

11.1 Analytical chemical methods are given in Specification B824.

11.1.1 Test methods to be followed for the determination of elements resulting from contractual or purchase order agreement shall be as agreed upon between the manufacturer or supplier and the purchaser.

## 12. ASME Requirements

12.1 Castings shall comply with the following:

12.1.1 Certification requirements of Specification B824.

12.1.2 Foundry test report requirements of Specification B824.

12.1.3 Castings shall be marked with the manufacturer's name, the copper alloy UNS number, and the casting quality factor. In addition, heat numbers or serial numbers that are traceable to heat numbers shall be marked on all pressure-containing castings individually weighing 50 lb (22.7 kg) or more. Pressure-containing castings weighing less than 50 lb (22.7 kg) shall be marked with either the heat number or a serial number that will identify the casting as to the month in which it was poured. Marking shall be in such a position as to not injure the usefulness of the casting.

## 13. Keywords

13.1 copper-alloy castings; copper-nickel castings; UNS No. C96200; UNS No. C96400

## SUPPLEMENTARY REQUIREMENTS

The following supplementary requirements shall apply only when specified by the purchaser in the inquiry, contract, or order, for agencies of the U.S. government.

### S1. Referenced Documents

S1.1 The following documents of the issue in effect on date of material purchase form a part of this specification to the extent referenced herein:

S1.1.1 *ASTM Standard:*

B900 Practice for Packaging of Copper and Copper Alloy Mill Products for U.S. Government Agencies

S1.1.12 *Federal Standards:*<sup>6</sup>

Fed. Std. No. 102 Preservation, Packaging, and Packing Levels

Fed. Std. No. 123 Marking for Shipment (Civil Agencies)

Fed. Std. No. 185 Identification Marking of Copper and Copper-Base Alloy Mill Products

S1.1.13 *Military Standards:*

MIL-STD-129 Marking for Shipment and Storage

MIL-STD-248 Welded and Brazing Procedure in Performance Qualification

MIL-STD-278 Welding and Casting Standard

### S2. Soundness

S2.1 Castings shall meet the soundness requirements of MIL-STD-278 for the category, sub-category, and criticality level specified in the purchase order.

### S3. Pressure Test

S3.1 Castings shall meet the pressure test requirements of MIL-STD-278.

### S4. Weld Repair

S4.1 All repair welding shall be in accordance with MIL-STD-278 using welders and welding procedures qualified in accordance with MIL-STD-248.

### S5. Quality Assurance

S5.1 *Responsibility for Inspection:*

S5.1.1 Unless otherwise specified in the contract or purchase order, the manufacturer is responsible for the performance of all inspection and test requirements specified. Except as otherwise specified in the contract or purchase order, the manufacturer may use his own or any other suitable facilities for the performance of the inspection and test requirements unless disapproved by the purchaser at the time the order is placed. The purchaser shall have the right to perform any of the inspections or tests set forth when such inspections and tests are deemed necessary to ensure that the material conforms to prescribed requirements.

### S6. Product Marking

S6.1 The castings shall be permanently marked in accordance with MIL-STD-792 and include specification and alloy number, pattern or drawing number, lot number, and manufacturer's name or trademark.

### S7. Preparation for Delivery

S7.1 *Preservation, Packaging, and Packing:*

S7.1.1 *Military Agencies*—The material shall be separated by size, composition, grade, or class and shall be preserved and packaged, Level A or C, packed, Level A, B, or C as specified in the contract or purchase order, in accordance with the requirements of Practice B900.

S7.1.2 *Civil Agencies*—The requirements of Fed. Std. No. 102 shall be referenced for definitions of the various levels of packaging protection.

S7.2 *Marking:*

S7.2.1 *Military Agencies*—In addition to any special marking required by the contract or purchase order, marking for shipment shall be in accordance with MIL-STD-129.

S7.2.2 *Civil Agencies*—In addition to any special marking required by the contract or purchase order, marking for shipment shall be in accordance with Fed. Std. No. 123.

ASMENORMDOC.COM : Click to view the full PDF of ASME BPVC.II.B (ASME BPVC Section II part B) 2025

INTENTIONALLY LEFT BLANK

# SPECIFICATION FOR TITANIUM AND TITANIUM ALLOY FORGINGS



**SB-381**

(Identical with ASTM Specification B381-13(2019) except that Note A of Table 1 has been revised.)

ASMENORMDOC.COM : Click to view the full PDF of ASME BPVC.II.B (ASME BPVC Section II part B) 2025

## Specification for Titanium and Titanium Alloy Forgings

### 1. Scope

1.1 This specification covers 39 grades of annealed titanium and titanium alloy forgings as follows:

1.1.1 *Grade F-1*—UNS R50250. Unalloyed titanium,

1.1.2 *Grade F-2*—UNS R50400. Unalloyed titanium,

1.1.2.1 *Grade F-2H*—UNS R50400. Unalloyed titanium (Grade 2 with 58 ksi (400 MPa) minimum UTS),

1.1.3 *Grade F-3*—UNS R50550. Unalloyed titanium,

1.1.4 *Grade F-4*—UNS R50700. Unalloyed titanium,

1.1.5 *Grade F-5*—UNS R56400. Titanium alloy (6 % aluminum, 4 % vanadium),

1.1.6 *Grade F-6*—UNS R54520. Titanium alloy (5 % aluminum, 2.5 % tin),

1.1.7 *Grade F-7*—UNS R52400. Unalloyed titanium plus 0.12 to 0.25 % palladium,

1.1.7.1 *Grade F-7H*—UNS R52400. Unalloyed titanium plus 0.12 to 0.25 % palladium (Grade 7 with 58 ksi (400 MPa) minimum UTS),

1.1.8 *Grade F-9*—UNS R56320. Titanium alloy (3 % aluminum, 2.5 % vanadium),

1.1.9 *Grade F-11*—UNS R52250. Unalloyed titanium plus 0.12 to 0.25 % palladium,

1.1.10 *Grade F-12*—UNS R53400. Titanium alloy (0.3 % molybdenum, 0.8 % nickel),

1.1.11 *Grade F-13*—UNS R53413. Titanium alloy (0.5 % nickel, 0.05 % ruthenium),

1.1.12 *Grade F-14*—UNS R53414. Titanium alloy (0.5 % nickel, 0.05 % ruthenium),

1.1.13 *Grade F-15*—UNS R53415. Titanium alloy (0.5 % nickel, 0.05 % ruthenium),

1.1.14 *Grade F-16*—UNS R52402. Unalloyed titanium plus 0.04 to 0.08 % palladium,

1.1.14.1 *Grade F-16H*—UNS R52402. Unalloyed titanium plus 0.04 to 0.08 % palladium (Grade 16 with 58 ksi (400 MPa) minimum UTS),

1.1.15 *Grade F-17*—UNS R52252. Unalloyed titanium plus 0.04 to 0.08 % palladium,

1.1.16 *Grade F-18*—UNS R56322. Titanium alloy (3 % aluminum, 2.5 % vanadium) plus 0.04 % to 0.08 % palladium,

1.1.17 *Grade F-19*—UNS R58640. Titanium alloy (3 % aluminum, 8 % vanadium, 6 % chromium, 4 % zirconium, 4 % molybdenum),

1.1.18 *Grade F-20*—UNS R58645. Titanium alloy (3 % aluminum, 8 % vanadium, 6 % chromium, 4 % zirconium, 4 % molybdenum) plus 0.04 to 0.08 % palladium,

1.1.19 *Grade F-21*—UNS R58210. Titanium alloy (3 % aluminum, 2.7 % niobium, 15 % molybdenum, 0.25 % silicon),

1.1.20 *Grade F-23*—UNS R56407. Titanium alloy (6 % aluminum, 4 % vanadium, extra low interstitials, ELI),

1.1.21 *Grade F-24*—UNS R56405. Titanium alloy (6 % aluminum, 4 % vanadium) plus 0.04 to 0.08 % palladium,

1.1.22 *Grade F-25*—UNS R56403. Titanium alloy (6 % aluminum, 4 % vanadium) plus 0.3 to 0.8 % nickel and 0.04 to 0.08 % palladium,

1.1.23 *Grade F-26*—UNS R52404. Unalloyed titanium plus 0.08 to 0.14 % ruthenium,

1.1.23.1 *Grade F-26H*—UNS R52404. Unalloyed titanium plus 0.08 to 0.14 % ruthenium (Grade 26 with 58 ksi (400 MPa) minimum UTS),

1.1.24 *Grade F-27*—UNS R52254. Unalloyed titanium plus 0.08 to 0.14 % ruthenium,

1.1.25 *Grade F-28*—UNS R56323. Titanium alloy (3 % aluminum, 2.5 % vanadium plus 0.08 to 0.14 % ruthenium),

1.1.26 *Grade F-29*—UNS R56404. Titanium alloy (6 % aluminum, 4 % vanadium, extra low interstitial, ELI plus 0.08 to 0.14 % ruthenium),

1.1.27 *Grade F-30*—UNS R53530. Titanium alloy (0.3 % cobalt, 0.05 % palladium),

1.1.28 *Grade F-31*—UNS R53532. Titanium alloy (0.3 % cobalt, 0.05 % palladium),

1.1.29 *Grade F-32*—UNS R55111. Titanium alloy (5 % aluminum, 1 % vanadium, 1 % tin, 1 % zirconium, 0.8 % molybdenum),

1.1.30 *Grade F-33*—UNS R53442. Titanium alloy (0.4 % nickel, 0.015 % palladium, 0.025 % ruthenium, 0.15 % chromium),

1.1.31 *Grade F-34*—UNS R53445. Titanium alloy (0.4 % nickel, 0.015 % palladium, 0.025 % ruthenium, 0.15 % chromium),

1.1.32 *Grade F-35*—UNS R56340. Titanium alloy (4.5 % aluminum, 2 % molybdenum, 1.6 % vanadium, 0.5 % iron, 0.3 % silicon),

1.1.33 *Grade F-36*—UNS R58450. Titanium alloy (45 % niobium),

1.1.34 *Grade F-37*—UNS R52815. Titanium alloy (1.5 % aluminum), and

1.1.35 *Grade F-38*—UNS R54250. Titanium alloy (4 % aluminum, 2.5 % vanadium, 1.5 % iron).

NOTE 1—H grade material is identical to the corresponding numeric grade (that is, Grade 2H = Grade 2) except for the higher guaranteed minimum UTS, and may always be certified as meeting the requirements of its corresponding numeric grade. Grades 2H, 7H, 16H, and 26H are intended primarily for pressure vessel use.

1.2 The values stated in inch-pound units are to be regarded as standard. The values given in parentheses are mathematical conversions to SI units that are provided for information only and are not considered standard.

1.3 *This international standard was developed in accordance with internationally recognized principles on standardization established in the Decision on Principles for the Development of International Standards, Guides and Recommendations issued by the World Trade Organization Technical Barriers to Trade (TBT) Committee.*

## 2. Referenced Documents

### 2.1 ASTM Standards:

B348 Specification for Titanium and Titanium Alloy Bars and Billets

E8 Test Methods for Tension Testing of Metallic Materials [Metric] E0008\_E0008M

E29 Practice for Using Significant Digits in Test Data to Determine Conformance with Specifications

E539 Test Method for Analysis of Titanium Alloys by Wavelength Dispersive X-Ray Fluorescence Spectrometry

E1409 Test Method for Determination of Oxygen and Nitrogen in Titanium and Titanium Alloys by Inert Gas Fusion

E1447 Test Method for Determination of Hydrogen in Titanium and Titanium Alloys by Inert Gas Fusion Thermal Conductivity/Infrared Detection Method

E1941 Test Method for Determination of Carbon in Refractory and Reactive Metals and Their Alloys by Combustion Analysis

E2371 Test Method for Analysis of Titanium and Titanium Alloys by Direct Current Plasma and Inductively Coupled Plasma Atomic Emission Spectrometry (Performance-Based Test Methodology)

E2626 Guide for Spectrometric Analysis of Reactive and Refractory Metals (Withdrawn 2017)

## 3. Terminology

### 3.1 Definitions of Terms Specific to This Standard:

3.1.1 *bar, n*—a hot rolled, forged or cold worked semifinished solid section product whose cross sectional area is less than 16 in.<sup>2</sup> (10 323 mm<sup>2</sup>).

3.1.2 *billet, n*—a solid semifinished section, hot rolled or forged from an ingot, with a cross sectional area greater than 16 in.<sup>2</sup> (10 323 mm<sup>2</sup>).

3.1.3 *forging, n*—any product of work on metal formed to a desired shape by impact or pressure in hammers, forging machines, upsetters presses or related forming equipment.

## 4. Ordering Information

4.1 Orders for forgings under this specification shall include the following information, as applicable:

4.1.1 Grade number (Section 1),

4.1.2 Tensile properties (Table 1),

4.1.3 Dimensions and tolerances (Section 10),

4.1.4 Sampling, mechanical properties (Section 8),

4.1.5 Methods for chemical analysis (Section 6),

4.1.6 Marking (Section 17),

4.1.7 Packaging (Section 17),

4.1.8 Certification (Section 16),

4.1.9 Disposition of rejected material (Section 14), and

4.1.10 Supplementary requirements (S1).

## 5. Materials and Manufacture

5.1 Material conforming to the latest revision of Specification B348 shall be used when producing forgings to this specification.

## 6. Chemical Composition

6.1 The grades of titanium and titanium alloy metal covered by this specification shall conform to the requirements as to chemical composition prescribed in Table 2.

6.1.1 The elements listed in Table 2 are intentional alloy additions or elements which are inherent to the manufacturer of titanium sponge, ingot or mill product.

6.1.1.1 Elements other than those listed in Table 2 are deemed to be capable of occurring in the grades listed in Table 2 by and only by way of unregulated or unanalyzed scrap additions to the ingot melt. Therefore, product analysis for elements not listed in Table 2 shall not be required unless specified and shall be considered to be in excess of the intent of this specification.

6.1.2 Elements intentionally added to the melt must be identified, analyzed, and reported in the chemical analysis.

6.2 When agreed upon by the producer and purchaser and requested by the purchaser in his written purchase order, chemical analysis shall be completed for specific residual elements not listed in this specification.

6.3 *Product Analysis*—Product analysis tolerances do not broaden the specified heat analysis requirements, but cover variations between laboratories in the measurement of chemical content. The manufacturer shall not ship material which is outside the limits specified in Table 2 for the applicable grade. Product analysis limits shall be as specified in Table 3.

TABLE 1 Tensile Requirements<sup>A</sup>

Grade	Tensile Strength, min		Yield Strength (0.2 % Offset), min or Range		Elongation in 4D, min, %	Reduction of Area, min, %
	ksi	(MPa)	ksi	(MPa)		
F-1	35	(240)	20	(138)	24	30
F-2	50	(345)	40	(275)	20	30
F-2H <sup>B,C</sup>	58	(400)	40	(275)	20	30
F-3	65	(450)	55	(380)	18	30
F-4	80	(550)	70	(483)	15	25
F-5	130	(895)	120	(828)	10	25
F-6	120	(828)	115	(795)	10	25
F-7	50	(345)	40	(275)	20	30
F-7H <sup>B,C</sup>	58	(400)	40	(275)	20	30
F-9	120	(828)	110	(759)	10	25
F-9 <sup>D</sup>	90	(620)	70	(483)	15	25
F-11	35	(240)	20	(138)	24	30
F-12	70	(483)	50	(345)	18	25
F-13	40	(275)	25	(170)	24	30
F-14	60	(410)	40	(275)	20	30
F-15	70	(483)	55	(380)	18	25
F-16	50	(345)	40	(275)	20	30
F-16H <sup>B,C</sup>	58	(400)	40	(275)	20	30
F-17	35	(240)	20	(138)	24	30
F-18	90	(620)	70	(483)	15	25
F-18 <sup>D</sup>	90	(620)	70	(483)	12	20
F-19 <sup>E</sup>	115	(793)	110	(759)	15	25
F-19 <sup>F</sup>	135	(930)	130 to 159	(897) to (1096)	10	20
F-19 <sup>G</sup>	165	(1138)	160 to 185	(1104) to (1276)	5	20
F-20 <sup>E</sup>	115	(793)	110	(759)	15	25
F-20 <sup>F</sup>	135	(930)	130 to 159	(897) to (1096)	10	20
F-20 <sup>G</sup>	165	(1138)	160 to 185	(1104) to (1276)	5	20
F-21 <sup>E</sup>	115	(793)	110	(759)	15	35
F-21 <sup>F</sup>	140	(966)	130 to 159	(897) to (1096)	10	30
F-21 <sup>G</sup>	170	(1172)	160 to 185	(1104) to (1276)	8	20
F-23	120	(828)	110	(759)	10	25
F-23 <sup>D</sup>	120	(828)	110	(759)	7.5 <sup>H</sup> , 6.0 <sup>I</sup>	25
F-24	130	(895)	120	(828)	10	25
F-25	130	(895)	120	(828)	10	25
F-26	50	(345)	40	(275)	20	30
F-26H <sup>B,C</sup>	58	(400)	40	(275)	20	30
F-27	35	(240)	20	(138)	24	30
F-28	90	(620)	70	(483)	15	25
F-28 <sup>D</sup>	90	(620)	70	(483)	12	20
F-29	120	(828)	110	(759)	10	25
F-29 <sup>D</sup>	120	(828)	110	(759)	7.5 <sup>H</sup> , 6.0 <sup>I</sup>	15
F-30	50	(345)	40	(275)	20	30
F-31	65	(450)	55	(380)	18	30
F-32	100	(689)	85	(586)	10	25
F-33	50	(345)	40	(275)	20	30
F-34	65	(450)	55	(380)	18	30
F-35	130	(895)	120	(828)	5	20
F-36	65	(450)	60 to 95	(410 to 655)	10	...
F-37	50	(345)	31	(215)	20	30
F-38	130	(895)	115	(794)	10	25

<sup>A</sup> These properties apply to forgings having a cross section no greater than 3 in.<sup>2</sup> (1935 mm<sup>2</sup>).

<sup>B</sup> Material is identical to the corresponding numeric grade (that is, Grade F-2H = Grade F-2) except for the higher guaranteed minimum UTS, and may be dual certified with its corresponding numeric grade. Grade F-2H, F-7H, F-16H, and F-26H are intended primarily for pressure vessel use.

<sup>C</sup> The H grades were added in response to a user association request based on its study of over 5200 commercial Grade 2, 7, 16, and 26 test reports where over 99 % met the 58 ksi minimum UTS.

<sup>D</sup> Properties for material in transformed-beta condition.

<sup>E</sup> Properties for material in the solution treated condition.

<sup>F</sup> Properties for solution treated and aged condition-Moderate strength (determined by aging temperature).

<sup>G</sup> Properties for solution treated and aged condition-High Strength (determined by aging temperature).

<sup>H</sup> For product section or wall thickness values <1.0 in.

<sup>I</sup> For product section or wall thickness values ≥1.0 in.

6.4 Sampling—Samples for chemical analysis shall be representative of material being tested. Except for hydrogen and unless otherwise specified, chemical analysis of ingot or billet shall be reported. Samples for hydrogen determination shall be

obtained from the forgings on a test basis and a frequency as agreed upon between the forger and the purchaser. The utmost care must be used in sampling titanium for chemical analysis because of its great affinity for elements such as oxygen,

TABLE 2 Chemical Requirements

Composition, Weight Percent<sup>A,B,C,D,E</sup>

Grade	UNS Number	Carbon, max.	Oxygen, range or max.	Nitrogen, max.	Hydrogen, max.	Iron, range or max.	Aluminum	Vanadium	Palladium	Ruthenium	Nickel	Molybdenum	Chromium	Cobalt	Zirconium	Niobium	Tin	Silicon	Other Elements, max. each	Other Elements, max. total
F-1	R50250	0.08	0.18	0.03	0.015	0.20	--	--	--	--	--	--	--	--	--	--	--	--	0.1	0.4
F-2/ F-2H	R50400	0.08	0.25	0.03	0.015	0.30	--	--	--	--	--	--	--	--	--	--	--	--	0.1	0.4
F-3	R50550	0.08	0.35	0.05	0.015	0.30	--	--	--	--	--	--	--	--	--	--	--	--	0.1	0.4
F-4	R50700	0.08	0.40	0.05	0.015	0.50	--	--	--	--	--	--	--	--	--	--	--	--	0.1	0.4
F-5	R56400	0.08	0.20	0.05	0.015	0.40	5.5- 6.75	3.5- 4.5	--	--	--	--	--	--	--	--	--	--	0.1	0.4
F-6	R54520	0.08	0.20	0.03	0.015	0.50	4.0- 6.0	--	--	--	--	--	--	--	--	--	2.0- 3.0	--	0.1	0.4
F-7/ F-7H	R52400	0.08	0.25	0.03	0.015	0.30	--	--	0.12- 0.25	--	--	--	--	--	--	--	--	--	0.1	0.4
F-9	R56320	0.08	0.15	0.03	0.015	0.25	2.5- 3.5	2.0- 3.0	--	--	--	--	--	--	--	--	--	--	0.1	0.4
F-11	R52250	0.08	0.18	0.03	0.015	0.20	--	--	0.12- 0.25	--	--	--	--	--	--	--	--	--	0.1	0.4
F-12	R53400	0.08	0.25	0.03	0.015	0.30	--	--	--	--	0.6- 0.9	0.2- 0.4	--	--	--	--	--	--	0.1	0.4
F-13	R53413	0.08	0.10	0.03	0.015	0.20	--	--	--	0.04- 0.06	0.4- 0.6	--	--	--	--	--	--	--	0.1	0.4
F-14	R53414	0.08	0.15	0.03	0.015	0.30	--	--	--	0.04- 0.06	0.4- 0.6	--	--	--	--	--	--	--	0.1	0.4
F-15	R53415	0.08	0.25	0.05	0.015	0.30	--	--	--	0.04- 0.06	0.4- 0.6	--	--	--	--	--	--	--	0.1	0.4
F-16/ F-16H	R52402	0.08	0.25	0.03	0.015	0.30	--	--	0.04- 0.08	--	--	--	--	--	--	--	--	--	0.1	0.4
F-17	R52252	0.08	0.18	0.03	0.015	0.20	--	--	0.04- 0.08	--	--	--	--	--	--	--	--	--	0.1	0.4
F-18	R56322	0.08	0.15	0.03	0.015	0.25	2.5- 3.5	2.0- 3.0	0.04- 0.08	--	--	--	--	--	--	--	--	--	0.1	0.4
F-19	R58640	0.05	0.12	0.03	0.02	0.30	3.0- 4.0	7.5- 8.5	--	--	--	3.5- 4.5	5.5- 6.5	--	3.5- 4.5	--	--	--	0.15	0.4
F-20	R58645	0.05	0.12	0.03	0.02	0.30	3.0- 4.0	7.5- 8.5	0.04- 0.08	--	--	3.5- 4.5	5.5- 6.5	--	3.5- 4.5	--	--	--	0.15	0.4
F-21	R58210	0.05	0.17	0.03	0.015	0.40	2.5- 3.5	--	--	--	--	14.0- 16.0	--	--	--	2.2- 3.2	--	0.15- 0.25	0.1	0.4
F-23	R56407	0.08	0.13	0.03	0.0125	0.25	5.5- 6.5	3.5- 4.5	--	--	--	--	--	--	--	--	--	--	0.1	0.4
F-24	R56405	0.08	0.20	0.05	0.015	0.40	5.5- 6.75	3.5- 4.5	0.04- 0.08	--	--	--	--	--	--	--	--	--	0.1	0.4
F-25	R56403	0.08	0.20	0.05	0.015	0.40	5.5- 6.75	3.5- 4.5	0.04- 0.08	--	0.3- 0.8	--	--	--	--	--	--	--	0.1	0.4
F-26/ F-16H	R52404	0.08	0.25	0.03	0.015	0.30	--	--	--	0.08- 0.14	--	--	--	--	--	--	--	--	0.1	0.4
F-27	R52254	0.08	0.18	0.03	0.015	0.20	--	--	--	0.08- 0.14	--	--	--	--	--	--	--	--	0.1	0.4
F-28	R56323	0.08	0.15	0.03	0.015	0.25	2.5- 3.5	2.0- 3.0	--	0.08- 0.14	--	--	--	--	--	--	--	--	0.1	0.4
F-29	R56404	0.08	0.13	0.03	0.0125	0.25	5.5- 6.5	3.5- 4.5	--	0.08- 0.14	--	--	--	--	--	--	--	--	0.1	0.4
F-30	R53530	0.08	0.25	0.03	0.015	0.30	--	--	0.04- 0.08	--	--	--	--	0.20- 0.80	--	--	--	--	0.1	0.4
F-31	R53532	0.08	0.35	0.05	0.015	0.30	--	--	0.04- 0.08	--	--	--	--	0.20- 0.80	--	--	--	--	0.1	0.4

ASMENORMDOC.COM Click to view the full PDF of ASME BPVC II.B (ASME BPVC Section II part B) 2025

TABLE 2 Continued

Composition, Weight Percent<sup>A,B,C,D,E</sup>

Grade	UNS Number	Carbon, max.	Oxygen range or max.	Nitrogen, max.	Hydrogen, max.	Iron range or max.	Aluminum	Vanadium	Palladium	Ruthenium	Nickel	Molybdenum	Chromium	Cobalt	Zirconium	Niobium	Tin	Silicon	Other Elements, max. each	Other Elements, max. total
F-32	R55111	0.08	0.11	0.03	0.015	0.25	4.5-5.5	0.6-1.4	--	--	--	0.6-1.2	--	--	0.6-1.4	--	0.6-1.4	0.06-0.14	0.1	0.4
F-33	R53442	0.08	0.25	0.03	0.015	0.30	--	--	0.01-0.02	0.02-0.04	0.35-0.55	--	0.1-0.2	--	--	--	--	--	0.1	0.4
F-34	R53445	0.08	0.35	0.05	0.015	0.30	--	--	0.01-0.02	0.02-0.04	0.35-0.55	--	0.1-0.2	--	--	--	--	--	0.1	0.4
F-35	R56340	0.08	0.25	0.05	0.015	0.20-0.80	4.0-5.0	1.1-2.1	--	--	--	1.5-2.5	--	--	--	--	--	0.20-0.40	0.1	0.4
F-36	R58450	0.04	0.16	0.03	0.015	0.03	--	--	--	--	--	--	--	--	--	42.0-47.0	--	--	0.1	0.4
F-37	R52815	0.08	0.25	0.03	0.015	0.30	1.0-2.0	--	--	--	--	--	--	--	--	--	--	--	0.1	0.4
F-38	R54250	0.08	0.20-0.30	0.03	0.015	1.2-1.8	3.5-4.5	2.0-3.0	--	--	--	--	--	--	--	--	--	--	0.1	0.4

<sup>A</sup> At minimum, the analysis of samples from the top and bottom of the ingot shall be completed and reported for all elements listed for the respective grade in this table.

<sup>B</sup> Final product hydrogen shall be reported. Ingot hydrogen need not be reported. Lower hydrogen may be obtained by negotiation with the manufacturer.

<sup>C</sup> Single values are maximum. The percentage of titanium is determined by difference.

<sup>D</sup> Other elements need not be reported unless the concentration level is greater than 0.1 % each, or 0.4 % total. Other elements may not be added intentionally. Other elements may be present in titanium or titanium alloys in small quantities and are inherent to the manufacturing process. In titanium these elements typically include aluminum, vanadium, tin, chromium, molybdenum, niobium, zirconium, hafnium, bismuth, ruthenium, palladium, yttrium, copper, silicon, cobalt, tantalum, nickel, boron, manganese, and tungsten.

<sup>E</sup> The purchaser may, in the written purchase order, request analysis for specific residual elements not listed in this specification.

ASMENORMDOC.COM : Click to view the full PDF of ASME BPVC.II.B (ASME BPVC Section II part B) 2025

TABLE 3 Permissible Variations in Product Analysis

Element	Product Analysis Limits, max or Range, %	Permissible Variation in Product Analysis
Aluminum	0.5 to 2.5	±0.20
Aluminum	2.5 to 6.75	±0.40
Carbon	0.10	+0.02
Chromium	0.1 to 0.2	±0.02
Chromium	5.5 to 6.5	±0.30
Cobalt	0.2 to 0.8	±0.05
Hydrogen	0.02	+0.002
Iron	0.80	+0.15
Iron	1.2 to 1.8	±0.20
Molybdenum	0.2 to 0.4	±0.03
Molybdenum	0.6 to 1.2	±0.15
Molybdenum	1.5 to 4.5	±0.20
Molybdenum	14.0 to 16.0	±0.50
Nickel	0.3 to 0.9	±0.05
Niobium	2.2 to 3.2	±0.15
Niobium	>30	±0.50
Nitrogen	0.05	+0.02
Oxygen	0.30	+0.03
Oxygen	0.31 to 0.40	±0.04
Palladium	0.01 to 0.02	±0.002
Palladium	0.04 to 0.08	±0.005
Palladium	0.12 to 0.25	±0.02
Ruthenium	0.02 to 0.04	±0.005
Ruthenium	0.04 to 0.06	±0.005
Ruthenium	0.08 to 0.14	±0.01
Silicon	0.06 to 0.40	±0.02
Tin	0.6 to 3.0	±0.15
Vanadium	0.6 to 4.5	±0.15
Vanadium	7.5 to 8.5	±0.40
Zirconium	0.6 to 1.4	±0.15
Zirconium	3.5 to 4.5	±0.20
Residuals <sup>A</sup> (each)	0.15	+0.02

<sup>A</sup> A residual is an element present in a metal or an alloy in small quantities and is inherent to the manufacturing process but not added intentionally. In titanium these elements include aluminum, vanadium, tin, iron, chromium, molybdenum, niobium, zirconium, hafnium, bismuth, ruthenium, palladium, yttrium, copper, silicon, cobalt, tantalum, nickel, boron, manganese, and tungsten.

nitrogen, and hydrogen. Therefore, the cutting and handling of samples should include practices that will prevent contamination. Samples shall be collected from clean metal.

6.5 At least two samples for chemical analysis shall be tested to determine chemical composition. Samples shall be taken from opposite extremes of the product to be analyzed.

## 7. Methods of Chemical Analysis

7.1 The chemical analysis shall normally be conducted using the ASTM standard test methods referenced in 2.1. Other industry standard methods may be used where the ASTM test methods in 2.1 do not adequately cover the elements in the material or by agreement between the producer and purchaser. Alternate techniques are discussed in Guide E2626.

## 8. Mechanical Properties

8.1 Forgings supplied under this specification shall conform to the requirements as to mechanical properties specified in Table 1, as applicable.

8.2 Specimens for tension tests shall be machined and tested in accordance with Test Methods E8. Tensile properties shall be determined using a strain rate of 0.003 to 0.007 in./in.·min through the specified yield strength. After the specified yield strength has been reached, the crosshead speed shall be

increased to a rate sufficient to produce fracture in approximately one additional minute.

8.3 *Sampling*—Tension test specimens shall be machined from material as agreed upon by the manufacturer and the purchaser.

## 9. Nondestructive Tests

9.1 Nondestructive test requirements such as ultrasonic test, X ray, or surface inspection shall be specified by the purchaser, if required. The standard for acceptance or rejection shall be agreed upon between the forger and the purchaser.

## 10. Dimensions and Permissible Variations

10.1 Dimensions and tolerances of titanium and titanium alloy forgings covered by this specification shall be as shown on the applicable forging drawing or otherwise agreed upon by the manufacturer and the purchaser.

## 11. Workmanship, Finish, and Appearance

11.1 Titanium alloy forgings shall be free of injurious external and internal imperfections of a nature that will interfere with the purpose for which they are intended. Annealed forgings may be furnished as descaled, sandblasted, or ground. The manufacturer shall be permitted to remove minor surface imperfections by spot grinding if such grinding does not reduce the thickness of the forging below the minimum permitted by the tolerance for the forging at the applicable location.

## 12. Retests

12.1 If the results of any chemical or mechanical property test lot are not in conformance with the requirements of this specification, the lot may be retested at the option of the manufacturer. The frequency of the retest will double the initial number of tests. If the results of the retest conform to the specification, then the retest values will become the test values for certification. Only original conforming test results or the conforming retest results shall be reported to the purchaser. If the results for the retest fail to conform to the specification, the material will be rejected in accordance with Section 14.

## 13. Rounding-Off Procedure

13.1 For purposes of determining conformance with this specification, an observed or a calculated value shall be rounded off to the nearest “unit” in the last right-hand significant digit used in expressing the limiting value. This is in accordance with the round-off method of Practice E29.

## 14. Rejection

14.1 Forgings not conforming to this specification or to authorized modifications shall be subject to rejection. Unless otherwise specified, rejected forgings may be returned to the manufacturer at the manufacturer’s expense, unless the purchaser receives, within three weeks of notice of rejection, other instructions for disposition.

## 15. Referee Test and Analysis

15.1 In the event of disagreement between the manufacturer and the purchaser on the conformance of the material to the

requirements of this specification, a mutually acceptable referee shall perform the tests in question using the ASTM standard methods in 2.1. The referee's testing shall be used in determining conformance of the material to this specification.

## 16. Certification

16.1 The manufacturer shall supply at least one copy of the report certifying that the material supplied has been manufactured, inspected, sampled, and tested in accordance with the requirements of this specification and that the results of chemical analysis, tensile, and other tests meet the requirements of the specification for the grade specified. The report

shall include results of all chemical analysis, tensile tests, and all other tests required by the specification.

## 17. Packaging and Package Marking

17.1 *Packaging*—Unless otherwise specified, forgings purchased under this specification shall be packaged in accordance with the manufacturer's standard practice.

17.2 *Marking*—Forgings shall be marked for identification as agreed upon by the manufacturer and the purchaser.

## 18. Keywords

18.1 forgings; titanium; titanium alloys

## SUPPLEMENTARY REQUIREMENTS

### SUPPLEMENTARY REQUIREMENTS COVERING GRADE F3 TITANIUM FORGINGS

The following supplementary requirements are primarily intended for U.S. military applications and shall apply only when specified by the purchaser in the inquiry, contract or order.

#### S1. U.S. Military Requirements

S1.1 Referenced Documents section follows.

S1.2 Unless otherwise specified in the contract or purchase order, the seller is responsible for the performance of all inspection and test requirements in this specification, and the seller may use his or other suitable facilities for the performance of the inspection and testing.

S1.3 Grade F-3 composition shall be modified as follows:

Hydrogen	0.0125 max
Iron	0.20 max
Oxygen	0.26 max

S1.4 Two tensile specimens shall be taken from each lot of forgings up to and 125 pounds, and two tensile specimens shall be taken from each forging greater than 125 pounds for verification of compliance with Grade F-3 mechanical properties of Table 3. A lot shall constitute all forgings from the same heat, of the same design and size and heat treated in the same heat treat furnace load. The test specimens shall be taken from integral prolongations or extra forgings may be provided by the forger. Forgings under 3½ in. (90 mm) in cross section may use separately forged test bars provided the wall thickness and amount of working are equivalent to the forgings being supplied. Extra forgings may be provided for samples when forgings are over 3½ in. (90 mm) in cross section provided samples cannot be taken from prolongations or by trepanning. Samples shall be taken from the section of forging having the largest cross section. The longitudinal axis of the tensile specimens shall be parallel to the major direction of metal flow in the forging.

S1.5 Repair welding is not permitted.

S1.6 Each forging shall be ultrasonically inspected in accordance with MIL-STD-2154 throughout 100 % of their volume. Inspection shall be performed after heat treating when the forging is machined to the configuration for ultrasonic

inspection as shown on the forging sketch or drawing. Inspection shall be performed prior to drilling holes, cutting keyways, tapers, grooves, or machining section to final contour. Forgings shall be scanned using a straight beam technique such that all major planes are covered. Disc type forgings shall be scanned using a straight beam from at least one flat face and radially from the circumference when possible. Cylindrical, ring, and hollow forgings shall be scanned from the entire external surface using the straight beam technique, and in the axial direction to the maximum extent possible. Acceptance criteria shall be to class A of MIL-STD-2154.

S1.7 All surfaces of each forging shall be liquid penetrant inspected in accordance with NAVSEA T9074-AS-GIB-010/271. Acceptance criteria shall be in accordance with NAVSEA S9074-AR-GIB-010/278 as specified in the order.

S1.8 Forgings shall be free of foreign material and contaminants such as sulfur, lead, marking paints or machining or forming lubricants. Forgings shall be cleaned prior to any heat treatment operations. Forgings shall be free of any oxygen rich layer, such as alpha case.

S1.9 The first forging of each type and design submitted for inspection shall be the first article sample. Mechanical properties for first article inspections shall be determined throughout the forging as specified in the order (which should also include specific instructions regarding arrangements for examinations, approval of test results, and disposition of the first article samples), and the number and location of the test specimens and the acceptance criteria shall be as specified or as agreed upon between the contracting activity and the manufacturer. In addition, A full cross-section shall be macroetched in accordance with ASTM E340 and examined at 10× magnification for uniformity, soundness, grain size and grain flow. The macro etch cross section shall evidence uniformity of quality, soundness and freedom from cracks and porosity. A

fully wrought structure shall be evident and variation in grain size shall be such that it will not interfere with ultrasonic examination.

The manufacturer shall maintain a record of production practices used for the first article forging. In the event of change in the production practice in the same or subsequent order, the manufacturer shall notify the contracting activity and obtain approval of the changes. The manufacturer may be required to perform specific first article tests and examinations to verify that the change will not or has not degraded forging quality.

S1.10 The material shall be electron beam and/or plasma melted or shall be multiple melted with at least one of the melting cycles under vacuum.

## S2. Referenced Documents

### S2.1 *ASTM Standard:*

E340 Test Method for Macroetching Metals and Alloys

### S2.2 *Military Standards:*

T9074-AS-GIB-010/271 Requirements for Nondestructive Testing Methods

S9074-AR-GIB-010/278 Requirements for Fabrication Welding and Inspection, and Casting Inspection and Repair for Machinery, Piping, and Pressure Vessels

MIL-STD-2154 Inspection, Ultrasonic, Wrought Metals, Processing for

ASME NORMDOC.COM : Click to view the full PDF of ASME BPVC.II.B (ASME BPVC Section II Part B) 2025

ASMENORMDOC.COM : Click to view the full PDF of ASME BPVC.II.B (ASME BPVC Section II part B) 2025

INTENTIONALLY LEFT BLANK

# SPECIFICATION FOR U-BEND SEAMLESS COPPER AND COPPER ALLOY HEAT EXCHANGER AND CONDENSER TUBES



**SB-395/SB-395M**



(25)

(Identical with ASTM Specification B395/B395M-18 except certification and test reports have been made mandatory.)

*ASME SB-395/SB-395M replaces paras. 4.2.2, 4.2.7, 4.2.8, 4.4, 9.1.1, 21.1, 21.2, and 22.1 of ASTM B395/B395M with the following:*

4.2.2 DELETED

4.2.7 DELETED

4.2.8 DELETED

4.4 DELETED

9.1.1 Product shall have tensile properties as prescribed in Table 2 for product specified in inch-pound units or Table 3 for product specified in SI units. When tested in accordance with Test Methods E8/E8M.

21.1 The purchaser shall be furnished certification that samples representing each lot have been either tested or inspected as directed in this specification and requirements have been met.

21.2 DELETED

22.1 A report of test results shall be furnished shall be furnished to the purchaser.



Designation: B395/B395M – 18

# Standard Specification for U-Bend Seamless Copper and Copper Alloy Heat Exchanger and Condenser Tubes<sup>1</sup>

This standard is issued under the fixed designation B395/B395M; the number immediately following the designation indicates the year of original adoption or, in the case of revision, the year of last revision. A number in parentheses indicates the year of last reapproval. A superscript epsilon (ε) indicates an editorial change since the last revision or reapproval.

*This standard has been approved for use by agencies of the U.S. Department of Defense.*

## 1. Scope\*

1.1 This specification<sup>2</sup> establishes the requirements for condenser, evaporator, and heat exchanger U-bend tubes that are manufactured from seamless copper and copper alloy tube.

1.2 *Units*—The values stated in either SI units or inch-pound units are to be regarded separately as standard. Within the text, SI units are shown in brackets. The values stated in each system may not be exact equivalents; therefore, each system shall be used independently of the other. Combining values from the two systems may result in non-conformance with the standard.

1.3 This specification is applicable to product 2 in. [50 mm] or less, inclusive, in diameter.

1.4 The product shall be produced from one of the following coppers or copper alloys, as specified in the ordering information:

Copper or Copper Alloy UNS No.	Previously Used Designation	Type of Metal
C10200	OF <sup>A</sup>	oxygen-free without residual deoxidants
C10300	...	oxygen-free, extra low phosphorus
C10800	...	oxygen-free, low phosphorus
C12000	DLP <sup>A</sup>	phosphorized, low residual phosphorus
C12200	DHP <sup>A</sup>	phosphorized, high residual phosphorus
C14200	DPA <sup>A</sup>	phosphorized, arsenical
C19200	...	phosphorized, 1 % iron
C23000	...	red brass
C44300	Type B	admiralty metal
C44400	Type C	admiralty metal
C44500	Type D	admiralty metal
C60800	...	aluminum bronze
C68700	Type B	aluminum brass

<sup>1</sup> This specification is under the jurisdiction of ASTM Committee B05 on Copper and Copper Alloys and is the direct responsibility of Subcommittee B05.04 on Pipe and Tube.

Current edition approved March 1, 2018. Published April 2018. Originally approved in 1962. Last previous edition approved in 2016 as B395/B395M – 16. DOI: 10.1520/B0395\_B0395M-18.

<sup>2</sup> For ASME Boiler and Pressure Vessel Code applications see related Specification SB-395 in Section II of that Code.

Copper or Copper Alloy UNS No.	Previously Used Designation	Type of Metal
C70400	...	95-5 copper-nickel
C70600	...	90-10 copper-nickel
C70620	...	90-10 copper-nickel (modified for welding)
C71000	...	80-20 copper-nickel
C71500	...	70-30 copper-nickel
C71520	...	70-30 copper-nickel (modified for welding)
C72200	...	copper-nickel

<sup>A</sup> Designations listed in Classification B224.

1.5 The following safety hazard caveat pertains only to the test methods described in this specification.

1.5.1 *This standard does not purport to address all of the safety concerns, if any, associated with its use. It is the responsibility of the user of this standard to establish appropriate safety, health, and environmental practices and determine the applicability of regulatory limitations prior to use. (Warning—Mercury has been designated by many regulatory agencies as a hazardous substance that can cause serious medical issues. Mercury, or its vapor, has been demonstrated to be hazardous to health and corrosive to materials. Caution should be taken when handling mercury and mercury containing products. See the applicable product Safety Data Sheet (SDS) for additional information. Users should be aware that selling mercury and/or mercury containing products into your state or country may be prohibited by law.)*

1.6 *This international standard was developed in accordance with internationally recognized principles on standardization established in the Decision on Principles for the Development of International Standards, Guides and Recommendations issued by the World Trade Organization Technical Barriers to Trade (TBT) Committee.*

## 2. Referenced Documents

2.1 The following documents of the issue in effect on date of material purchase form a part of this specification to the extent referenced herein:

\*A Summary of Changes section appears at the end of this standard

## 2.2 ASTM Standards:<sup>3</sup>

- B153 Test Method for Expansion (Pin Test) of Copper and Copper-Alloy Pipe and Tubing
- B154 Test Method for Mercurous Nitrate Test for Copper Alloys
- B224 Classification of Coppers
- B601 Classification for Temper Designations for Copper and Copper Alloys—Wrought and Cast
- B846 Terminology for Copper and Copper Alloys
- B858 Test Method for Ammonia Vapor Test for Determining Susceptibility to Stress Corrosion Cracking in Copper Alloys
- B900 Practice for Packaging of Copper and Copper Alloy Mill Products for U.S. Government Agencies
- B968/B968M Test Method for Flattening of Copper and Copper-Alloy Pipe and Tube
- E3 Guide for Preparation of Metallographic Specimens
- E8/E8M Test Methods for Tension Testing of Metallic Materials
- E29 Practice for Using Significant Digits in Test Data to Determine Conformance with Specifications
- E53 Test Method for Determination of Copper in Unalloyed Copper by Gravimetry
- E62 Test Methods for Chemical Analysis of Copper and Copper Alloys (Photometric Methods) (Withdrawn 2010)<sup>4</sup>
- E112 Test Methods for Determining Average Grain Size
- E118 Test Methods for Chemical Analysis of Copper-Chromium Alloys (Withdrawn 2010)<sup>4</sup>
- E243 Practice for Electromagnetic (Eddy Current) Examination of Copper and Copper-Alloy Tubes
- E255 Practice for Sampling Copper and Copper Alloys for the Determination of Chemical Composition
- E478 Test Methods for Chemical Analysis of Copper Alloys
- E2575 Standard Test Method for Determination of Oxygen in Copper and Copper Alloys (Withdrawn 2017)<sup>4</sup>

## 2.3 Other Standard:<sup>5</sup>

ASME Boiler and Pressure Vessel Code

### 3. Terminology

3.1 For definitions of terms related to copper and copper alloys, refer to Terminology B846.

#### 3.2 Definitions of Terms Specific to This Standard:

3.2.1 *dual-gage tube, n*—a tube which has more than one wall-gage thickness contained within the length of the tube.

3.2.2 *squareness of cut, n*—the maximum deviation of one side of a cross section of tube from the opposite side, when measured against the projected perpendicularity of the plane of the projected center of the tube at the ends.

<sup>3</sup> For referenced ASTM standards, visit the ASTM website, [www.astm.org](http://www.astm.org), or contact ASTM Customer Service at [service@astm.org](mailto:service@astm.org). For *Annual Book of ASTM Standards* volume information, refer to the standard's Document Summary page on the ASTM website.

<sup>4</sup> The last approved version of this historical standard is referenced on [www.astm.org](http://www.astm.org).

<sup>5</sup> Available from American Society of Mechanical Engineers (ASME), ASME International Headquarters, Two Park Ave., New York, NY 10016-5990, <http://www.asme.org>.

3.2.3 *u-bend tube, n*—a tube bent 180° in a single plane into a U-shape.

### 4. Ordering Information

4.1 Include the following specified choices when placing orders for product under this specification, as applicable:

- 4.1.1 ASTM designation and year of issue,
- 4.1.2 Copper or copper alloy UNS No. designation (Section 6),
- 4.1.3 Temper (Section 7),
- 4.1.4 *Dimensions*—X—diameter and wall thickness of the tube (see 12.1 and 12.2),
- 4.1.5 Schedule of bending radii (must include the number of pieces of each radii) (see 12.2.5),
- 4.1.6 Length of U-bend tube legs (see 12.2.8),
- 4.1.7 If the product is to be subsequently welded (see Table 1), and
- 4.1.8 Intended application, and
- 4.1.9 If the product is to be for U.S. Government.

4.2 The following options are available but may not be included unless specified at the time of placing of the order when required:

- 4.2.1 Heat identification or traceability details (see 5.1.2).
- 4.2.2 Tension test (see 9.1),
- 4.2.3 Relief anneal of U-bent portion of copper-nickel U-bend tubes (see 7.6),
- 4.2.4 Dual-gage, a schedule of tubes required in dual-gage and length of heavy gage section must be furnished with this option (see 5.2.2 and 12.2.3),
- 4.2.5 Flattening Test (Section 10.2).
- 4.2.6 Expansion Test (Section 10.1).
- 4.2.7 Certification, if required (see Section 21), and
- 4.2.8 Mill Test Report, if required (see Section 22).

4.3 If product is purchased for agencies of the U.S. Government, it shall be in accordance with the requirements specified in the Supplementary Requirements section, when specified in the contract or purchase order.

4.4 If product is ordered for ASME Boiler and Pressure Vessel Code Application (See Certification Section 21).

### 5. Materials and Manufacture

#### 5.1 Materials:

5.1.1 The material of manufacture shall be of the copper alloys defined in 1.4 and of such quality and purity that the finished product shall have the properties and characteristics prescribed in this specification for the applicable alloy and temper.

5.1.2 When specified in the contract or purchase order that heat identification or traceability is required, the purchaser shall specify the details desired.

NOTE 1—Due to the discontinuous nature of the processing of casting into wrought products, it is not always practical to identify a specific casting analysis with a specific quantity of material.

#### 5.2 Manufacture:

5.2.1 The product shall be manufactured by such hot working, cold working and annealing processes as to produce a uniform wrought structure in the finished product.

TABLE 1 Chemical Requirements

Copper or Copper Alloy UNS No.	Composition, %												
	Copper	Tin	Aluminum	Nickel, incl Cobalt	Lead, max	Iron	Zinc	Manganese	Arsenic	Antimony	Phosphorus	Chromium	Other Named Elements
C10200 <sup>A,B</sup>	99.95 min	...	...	...	...	...	...	...	...	...	...	...	10 ppm max O
C10300 <sup>A</sup>	99.95 <sup>C</sup> min	...	...	...	...	...	...	...	...	...	0.001–0.005	...	...
C10800 <sup>A</sup>	99.95 <sup>C</sup> min	...	...	...	...	...	...	...	...	...	0.005–0.012	...	...
C12000 <sup>A</sup>	99.90 min	...	...	...	...	...	...	...	...	...	0.004–0.012	...	...
C12200 <sup>A</sup>	99.9 min	...	...	...	...	...	...	...	...	...	0.015–0.040	...	...
C14200 <sup>A</sup>	99.4 min	...	...	...	...	...	...	...	0.15–0.50	...	0.015–0.040	...	...
C19200 <sup>D</sup>	98.5 min	...	...	...	...	0.8–1.2	0.20 max	...	...	...	0.01–0.04	...	...
C23000 <sup>D</sup>	84.0–86.0	...	...	...	0.05	0.05 max	remainder	...	...	...	...	...	...
C44300 <sup>E</sup>	70.0–73.0	0.9–1.2	...	...	0.07	0.06 max	remainder	...	0.02–0.06	...	...	...	...
C44400 <sup>E</sup>	70.0–73.0	0.9–1.2	...	...	0.07	0.06 max	remainder	...	...	0.02–0.10	...	...	...
C44500 <sup>E</sup>	70.0–73.0	0.9–1.2	...	...	0.07	0.06 max	remainder	...	...	...	0.02–0.10	...	...
C60800 <sup>A,F</sup>	remainder	...	5.0–6.5	...	0.10	0.10 max	...	...	0.02–0.35	...	...	...	...
C68700 <sup>A,F</sup>	76.0–79.0	...	1.8–2.5	...	0.07	0.06 max	remainder	...	0.02–0.06	...	...	...	...
C70400 <sup>A,F</sup>	remainder	...	...	4.8–6.2	0.05	1.3–1.7	1.0 max	0.30 to 0.8	...	...	...	...	...
C70600 <sup>A,F</sup>	remainder	...	...	9.0–11.0	0.05	1.0–1.8	1.0 max	1.0 max <sup>G</sup>	...	...	...	...	...
C70620 <sup>A,F</sup>	86.5 min	...	...	9.0–11.0	0.02	1.0–1.8	0.50 max	1.0 max	...	...	0.02 max	...	0.05C max 0.02S max <sup>G</sup>
C71000 <sup>A,F,G</sup>	remainder	...	...	19.0–23.0	0.05 <sup>G</sup>	1.0 max	1.0 max <sup>G</sup>	1.0 max <sup>G</sup>	...	...	<sup>G</sup>	...	...
C71500 <sup>A,F</sup>	remainder	...	...	29.0–33.0	0.05	0.40–1.0	1.0 max	1.0 max	...	...	...	...	...
C71520 <sup>A,F</sup>	65.0 min	...	...	29.0–33.0	0.02	0.40–1.0	0.50 max	1.0 max	...	...	0.02 max	...	0.05C max 0.02S max <sup>G,H</sup>
C72200 <sup>A,D,G</sup>	remainder	...	...	15.0–18.0	0.05 <sup>G</sup>	0.50–1.0	1.0 max <sup>G</sup>	1.0 max	...	...	... <sup>G</sup>	0.30–0.70	...

<sup>A</sup> Silver counting as copper.

<sup>B</sup> This is a high conductivity copper which has, in the annealed condition, a minimum conductivity of 101 % IACS.

<sup>C</sup> Includes P.

<sup>D</sup> Cu + sum of named elements, 99.8 % min.

<sup>E</sup> Cu + sum of named elements, 99.6 % min.

<sup>F</sup> Cu + sum of named elements, 99.5 % min.

<sup>G</sup> When the product is for subsequent welding applications, and so specified by the purchaser, zinc shall be 0.50 %, max, lead 0.02 %, max, phosphorus 0.02 %, max, sulfur 0.02 %, max, and carbon 0.05 %, max.

<sup>H</sup> Silicon shall be 0.03 % max, titanium shall be 0.03 % max.

ASMENORMDOC.COM : Click to view the full PDF of ASME BPVC.II.B (ASME BPVC Section II part B) 2025

5.2.2 Tubes required to be U-bent to a small radius shall, if specified, be furnished as dual-gage tubes.

5.2.2.1 These tubes shall be made prior to U-bending with the wall thickness of the central section of the tube length, increased the equivalent of one Stubs' or Birmingham Wire Gage (BWG) thicker than the wall thickness specified for the straight leg portion of the U-bend tube.

5.2.2.2 Unless otherwise specified, dual-gage tubes shall be made to constant inside diameter; that is, the increased wall thickness shall be obtained by increasing the outside diameter of the finished tube in the central heavy gage section.

5.2.3 The bent portion of the U-bend tube shall be substantially uniform in curvature.

## 6. Chemical Composition

6.1 The material shall conform to the chemical composition requirements specified in Table 1 for the copper or copper alloy UNS No. designation specified in the ordering information.

6.1.1 Results of analysis on a product (check) sample shall conform to the composition requirements within the permitted analytical variance specified in Table 1.

6.2 These composition limits do not preclude the presence of unnamed elements. By agreement between the manufacturer and purchaser, limits may be established and analysis required for unnamed elements.

6.3 *Copper Alloy UNS No. C19200*—Copper may be taken as the difference between the sum of all the elements analyzed and 100 %.

6.4 For copper alloys in which copper is specified as the remainder, copper may be taken as the difference between the sum of all the elements analyzed and 100 %.

6.5 For copper alloys in which zinc is specified as the remainder, either copper or zinc may be taken as the difference between the sum of all the elements analyzed and 100 %.

## 7. Temper

7.1 Tempers, as defined in Classification B601, are as follows:

7.2 Prior to U-bending, tubes of Copper Alloy UNS Nos. C23000, C44300, C44400, C44500, C60800, C68700, C70400, C70600, C70620, C71000, C71500, C71520, and C72200 shall be in the annealed temper (O61), unless otherwise specified in the purchase order.

7.3 Prior to bending, U-bend tubes of Copper Alloy UNS Nos. C10200, C10300, C10800, C12000, C12200, and C14200 shall be in light drawn temper (H55). Tubes of Copper Alloy UNS Nos. C70400, C70600, C70620, and C72200 shall, if specified, be made in the light-drawn temper (H55).

7.4 Prior to bending, U-bend tubes of Copper Alloy UNS No. C19200 shall be in the annealed (O61) or light drawn temper (H55) as specified.

7.5 Prior to bending, U-bend tubes of Copper Alloy UNS No. C71500 or C71520 shall be made in the drawn, stress-relieved temper (HR50), when specified.

7.6 The U-bend portion of tubes furnished in Copper Alloy UNS Nos. C23000, C44300, C44400, C44500, C60800, and C68700 shall be relief annealed (HR) after bending. If specified, the U-bend portion of tubes furnished in Copper Alloy UNS Nos. C70400, C70600, C70620, C71000, C71500, C71520, and C72200 shall be relief annealed (HR) after bending.

NOTE 2—Some tubes, when subjected to aggressive environments, may be subject to stress-corrosion cracking failure because of the residual tensile stresses developed in straightening. For such applications, it is suggested that tubes of Copper Alloy UNS Nos. C23000, C44300, C44400, C44500, C60800, and C68700 be subjected to a stress relieving (HR) thermal treatment subsequent to straightening. If required, this must be specified on the purchase order or contract. Tolerances for roundness and length, and the condition of straightness, for tube so ordered, shall be to the requirements agreed upon by the manufacturer and purchaser.

## 8. Grain Size for Annealed Tempers

8.1 Grain size shall be the standard requirement for all product in annealed tempers.

8.2 Acceptance or rejection based upon grain size shall depend only on the average grain size of a test specimen taken from each of two sample portions and each specimen shall be within the limits of 0.010 to 0.045 mm when determined in accordance with Test Methods E112.

8.3 The requirements of this section do not apply to product of the light-drawn temper (H55) drawn, stress-relieved temper (HR50), or to the U-bent portion of the product.

## 9. Mechanical Property Requirements

### 9.1 Tensile Strength Requirements:

9.1.1 Product specified to meet the requirements of *ASME Boiler and Pressure Vessel Code* shall have tensile properties as prescribed in Table 2 for product specified in inch-pound units or Table 3 for product specified in SI units. When tested in accordance with Test Methods E8/E8M.

## 10. Performance Requirements

### 10.1 Expansion Test:

10.1.1 When specified in the contract or purchaser order, tube specimens selected for test shall withstand the expansion shown in Table 4 when expanded in accordance with Test Method B153.

10.1.2 The expanded tube shall show no cracking or other defects visible to the unaided eye.

### 10.2 Flattening Test:

10.2.1 When specified in the contract or purchase order, the flattening test in accordance with Test Method B968/B968M shall be performed.

10.2.2 During inspection, the flattened areas of the test specimen shall be free of defects, but blemishes of a nature that do not interfere with the intended application are acceptable.

### 10.3 Residual Stress Test:

10.3.1 Product manufactured from Copper Alloy UNS Nos. C23000, C44300, C44400, C44500, C60800 and C68700 shall be tested for residual stress according to the requirements of Test Method B154 or Test Method B858 and show no signs of cracking.

TABLE 2 Tensile Requirements (Inch-Pound)

NOTE 1—For SI values, see Table 3.

Copper or Copper Alloy UNS No.	Temper Designation		Tensile Strength, min, ksi <sup>B</sup>	Yield Strength, <sup>A</sup> min, ksi <sup>B</sup>	Elongation in 2 in., min, %
	Temper Code	Temper Name			
C10200, C10300, C10800, C12000, C12200, C14200	H55	light drawn	36	30	...
C19200	H55	light drawn	40	35	...
C19200	O61	annealed	38	12	...
C23000	O61	annealed	40	12	...
C44300, C44400, C44500	O61	annealed	45	15	...
C60800	O61	annealed	50	19	...
C68700	O61	annealed	50	18	...
C70400	O61	annealed	38	12	...
C70400	H55	light drawn	40	30	...
C70600, C70620	O61	annealed	40	15	...
C70600, C70620	H55	light drawn	45	35	...
C71000	O61	annealed	45	16	...
C71500, C71520	O61	annealed	52	18	...
For wall thicknesses up to 0.048 in., incl	HR50	drawn, stress-relieved	72	50	12
For wall thicknesses over 0.048 in.	HR50	drawn, stress-relieved	72	50	15
C72200	O61	annealed	45	16	...
C72200	H55	light drawn	50	45	...

TABLE 3 Tensile Requirements (SI)

NOTE 1—For Inch-Pound values, see Table 2.

Copper or Copper Alloy UNS No.	Temper Designation		Tensile Strength, min, MPa	Yield Strength, <sup>A</sup> min, MPa	Elongation in 50.8 mm, min, %
	Temper Code	Temper Name			
C10200, C10300, C10800, C12000, C12200, C14200	H55	light drawn	250	205	...
C19200	H55	light drawn	275	240	...
C19200	O61	annealed	260	85	...
C23000	O61	annealed	275	85	...
C44300, C44400, C44500	O61	annealed	310	105	...
C60800	O61	annealed	345	130	...
C68700	O61	annealed	345	125	...
C70400	O61	annealed	260	85	...
C70400	H55	light drawn	275	205	...
C70600, C70620	O61	annealed	275	105	...
C70600, C70620	H55	light drawn	310	240	...
C71000	O61	annealed	310	110	...
C71500, C71520:	O61	annealed	360	125	...
For wall thicknesses up to 1.2 mm, incl	HR50	drawn, stress-relieved	495	345	12
For wall thicknesses over 1.2 mm	HR50	drawn, stress-relieved	495	345	15
C72200	O61	annealed	310	110	...
C72200	H55	light drawn	345	310	...

**Warning**—Mercury is a definite health hazard. With the Mercurous Nitrate Test, equipment for the detection and removal of mercury vapor produced in volatilization, and the use of protective gloves is recommended.

10.3.2 When the Ammonia Vapor Test is used, the test pH value appropriate for the intended application shall be 10 unless otherwise specified by the purchaser.

10.3.3 Residual stress test specimens shall be from both the U-bend and straight leg length and tested without bending, springing, polishing, or any other preparation, except as allowed by the test method.

NOTE 3—A residual stress test provides information about the adequacy of the stress relief of the material. Stress relief annealing is a method of thermal stress relief. There is no standard test method to evaluate the effectiveness of a relief-anneal (HR) of the U-bend section of copper-nickel or copper-nickel-iron tubes with respect to stress-corrosion cracking susceptibility.

11. Other Requirements

11.1 *Nondestructive Examination for Defects:*

11.1.1 Each tube, prior to bending, shall be subjected to the eddy-current test.

11.1.2 Tubes may be tested in the final drawn, annealed, or heat-treated temper or in the drawn temper prior to the final anneal or heat treatment at the option of the manufacturer.

11.1.3 Testing shall follow the procedures of Practice E243.

11.1.4 Unless otherwise agreed upon between the manufacturer, or supplier, and the purchaser, the manufacturer shall have the option of calibrating the test equipment using either notch-depth or drilled-hole standards. If agreement cannot be reached, notch-depth standard shall be utilized.

11.1.5 The depth of the round-bottom transverse notches and the diameters of the drilled holes in the calibrating tube used to adjust the sensitivity of the test unit are shown in Table

TABLE 4 Expansion Requirements

Temper Designation		Copper or Copper Alloy UNS No.	Expansion of Tube Outside Diameter in Percent Of Original Outside Diameter
Code	Name		
O61	annealed	C19200	30
		C23000	20
		C44300, C44400, C44500	20
		C60800	20
		C68700	20
		C70400	30
		C70600, C70620	30
		C71000	30
		C71500, C71520	30
		C72200	30
H55	light-drawn	C10200, C10300, C10800, C12000, C12200	20
		C14200	20
		C19200	20
		C70400	20
		C70600, C70620	20
		C72200	20
		C71500, C71520	20
			20
HR50	drawn, stress relieved		

5 and Table 7 for the material specified in the inch-pound system and Table 6 and Table 8 for material specified in the SI system.

11.1.6 Tubes that do not actuate the signaling device of the eddy-current tester shall be considered as conforming to the requirements of this test.

11.1.7 Tubes causing irrelevant signals because of moisture, soil, and minor mechanical damage may be reconditioned and retested.

11.1.8 Such tubes, when retested to the original test parameters, shall be considered to conform if they do not cause output signals beyond the acceptable limits.

11.1.9 Tubes causing irrelevant signals because of visible and identifiable handling marks shall be considered in conformance if the tube dimensions are within the prescribed limits and if the tubes conform to the leak test requirements of 11.2.2 or 11.2.3, unless otherwise agreed to by the manufacturer and purchaser.

11.2 Each U-bend tube shall be tested to the requirements of either 11.2.2 or 11.2.3.

11.2.1 Unless otherwise specified, the manufacturer shall have the option of the leak test to be used.

11.2.2 *Hydrostatic Test*—Each tube shall withstand an internal hydrostatic pressure sufficient to subject the material to a fiber stress of 7000 psi [48 MPa] without evidence of leakage. The tube need not be tested at a hydrostatic pressure of over a gage pressure of 1000 psi [6.9 MPa], unless so specified. The

TABLE 5 Notch Depth

Tube Wall Thickness, in.	Tube Outside Diameter, in.		
	Over ¼ to ¾, incl	Over ¾ to 1¼, incl	Over 1¼ to 2, incl
Over 0.017–0.032	0.005	0.006	0.007
Incl. 0.032–0.049	0.006	0.006	0.0075
Incl. 0.049–0.083	0.007	0.0075	0.008
Incl. 0.083–0.109	0.0075	0.0085	0.0095
Incl. 0.109–0.120	0.009	0.009	0.011

TABLE 6 Notch Depth (SI)

Tube Wall Thickness, mm	Tube Outside Diameter, mm		
	Over 6 to 19, incl	Over 19 to 32, incl	Over 32 to 50, incl
Over 0.43–0.81	0.13	0.15	0.18
Incl. 0.81–1.3	0.15	0.15	0.19
Incl. 1.3–2.1	0.18	0.19	0.20
Incl. 2.1–2.8	0.19	0.22	0.24
Incl. 2.8–3.0	0.23	0.23	0.28

TABLE 7 Diameter of Drilled Holes

Tube Outside Diameter, in.	Diameter of Drilled Holes, in.	Drill No.
¼ –¾, incl	0.025	72
Over ¾ –1, incl	0.031	68
Over 1 –1¼, incl	0.036	64
Over 1¼ –1½, incl	0.042	58
Over 1½ –1¾, incl	0.046	56
Over 1¾ –2, incl	0.052	55

TABLE 8 Diameter of Drilled Holes (SI)

Tube Outside Diameter, mm	Diameter of Drilled Holes, mm	Drill No.
6.0–19.0, incl	0.635	72
Over 19.0–25.0, incl	0.785	68
Over 25.0–32.0, incl	0.915	64
Over 32.0–38.0, incl	1.07	58
Over 38.0–45.0, incl	1.17	56
Over 45.0–50.0, incl	1.32	55

stress shall be determined by the following equation for thin hollow cylinders under tension:

$$P = 2St/(D - 0.8t) \quad (1)$$

where:

$P$  = hydrostatic pressure, psi [MPa],  
 $t$  = thickness of tube wall, in. [mm],  
 $D$  = outside diameter of the tube, in. [mm], and  
 $S$  = allowable stress of the material, psi [MPa].

11.2.3 *Pneumatic Test*—Each tube shall be subjected to an internal air gage pressure of 60 psi [400 kPa], minimum. The product shall maintain pressure and show no evidence of leakage for 5 s. The test method used shall permit visual detection of any leakage, such as by having the tube under water or by the pressure differential method. Any evidence of leakage shall be cause for rejection.

## 12. Dimensions, Mass, and Permissible Variations

12.1 *Tube Diameter*—The outside diameter of the straight leg portion of the tube, exclusive of the central heavy gage portion, shall not vary from that specified by more than the amounts shown in Table 9 for product specified in the inch-pound system or Table 10 for product specified in the SI system as measured by “go” and “no-go” ring gages.

### 12.2 Thickness:

12.2.1 *Tubes Ordered to Minimum Wall*—Prior to bending, the wall thickness of the single-gage tubes at the thinnest point shall not be less than the thickness specified. The maximum plus deviation from the specified wall at any point shall not

TABLE 9 Diameter Tolerances

Outside Diameter, in.	Wall Thickness, in.			
	0.032	0.035	0.042	0.049 and Over
	Diameter Tolerance, Plus and Minus, in.			
Up to 0.500 incl	0.0025	0.0025	0.0025	0.0025
Over 0.500–0.740, incl	0.004	0.004	0.0035	0.003
Over 0.740–1.000, incl	0.006	0.005	0.0045	0.004
Over 1.000–1.250, incl	0.009	0.008	0.006	0.0045
Over 1.250–1.375, incl	...	...	0.008	0.005
Over 1.375–2.000, incl	...	...	...	0.006

TABLE 10 Diameter Tolerances (SI)

Outside Diameter, mm	Wall Thickness, mm			
	0.813	0.889	1.07	1.24 and Over
	Diameter Tolerance, Plus and Minus, mm			
Up to 12.0, incl	0.064	0.064	0.064	0.064
Over 12.0–18.0, incl	0.010	0.10	0.089	0.076
Over 18.0–25.0, incl	0.15	0.13	0.11	0.10
Over 25.0–35.0, incl	...	...	0.20	0.13
Over 35.0–50.0, incl	...	...	...	0.15

exceed twice the value shown in Table 11 for product specified in the inch-pound system or Table 12 for product specified in the SI system.

12.2.2 Tubes Ordered to Nominal Wall:

12.2.2.1 Prior to bending the maximum plus and minus deviation from the nominal wall at any point shall not exceed the values shown in Table 11 for product specified in the inch-pound system or Table 12 for product specified in the SI system.

12.2.2.2 When tubes are required in dual-gage, the wall thickness of the heavy gage portion, prior to bending, shall conform to the applicable tolerances in Table 11 or Table 12 for the specified heavier gage (Note 4).

NOTE 4—The wall thickness of the heavy-gage section of the dual-gage tube shall be determined by adding one half the difference between the outside diameter at the heavy gage and the outside diameter of the standard gage to the minimum measured wall thickness determined at either end of the tube.

12.2.3 Wall Thickness of Tube in U-Bend Section—The wall thickness of the tube at the apex of the U-bent section shall be not less than the value determined by the following equation:

$$t_f = t(2R)/(2R + D) \tag{2}$$

TABLE 11 Wall Thickness Tolerances

Wall Thickness, in.	Outside Diameter, in.		
	Over 1/8 to 3/8, incl	Over 3/8 to 1, incl	Over 1 to 2, incl
	Wall Thickness Tolerances, Plus and Minus in.		
0.032, incl to 0.035	0.003	0.003	0.004
0.035, incl to 0.058	0.004	0.0045	0.0045
0.058, incl to 0.083	0.0045	0.005	0.005
0.083, incl to 0.120	0.005	0.0065	0.0065
0.120, incl to 0.134	0.007	0.007	0.0075

TABLE 12 Wall Thickness Tolerances (SI)

Wall Thickness, mm	Outside Diameter, mm		
	Over 3.0 to 16.0, incl	Over 16.0 to 25.0, incl	Over 25.0 to 50.0, incl
		Wall Thickness Tolerances, Plus and Minus mm	
0.813, incl to 0.889	0.076	0.076	0.10
0.889, incl to 1.47	0.10	0.11	0.11
1.47, incl to 2.11	0.11	0.13	0.13
2.11, incl to 3.05	0.13	0.17	0.17
3.05, incl to 3.40	0.18	0.18	0.19

where:

$t_f$  = thickness after bending, in. [mm],

$t$  = specified thickness of minimum wall or specified nominal wall minus the permissible wall thickness tolerance, in. [mm],

$R$  = centerline bend radius, in. [mm], and

$D$  = nominal outside diameter of the tube, in. [mm]

Proof of conformance to this requirement shall be obtained by bending a tube specimen representative of the material offered to the scheduled radius of bend cutting the tube at the apex of the bend, measuring the tube wall at the cross section of this apex section, and comparing the measured value with the calculated value of  $t_f$ .

12.2.4 Length of Central Heavy-Gage Section of Tube—The nominal length of the heavy-gage section of the dual-gage tube prior to bending shall be as specified but in no case shall the length of the heavy-gage section be specified less than 4 in. [100 mm] nor less than the length of the bend measured along the centerline bend radius between the points of tangency. The tolerance on the length of the heavy gage section shall be plus 3 in. [76 mm], minus 0 in. [0 mm]. The transition from the larger tube diameter of the heavy-gage section to the diameter of the tube in the standard-gage section shall be gradual and

take place in a distance of not less than  $\frac{1}{8}$  in. [3.2 mm] nor more than 1 in. [25 mm] measured parallel to the tube axis.

**12.2.5 Centering of U-Bend in Heavy-Gage Section of Tube**—U-bends in the dual-gage tube shall be centered substantially within the heavy-gage section of the tube. The heavy-gage section of the tube shall extend to or beyond the point of tangency, that is, the dimension  $a$  in Fig. 1 may be equal to or greater than 0 in. [0 mm]. The difference ( $b - a$ ) between the lengths of the heavy-gage section which extend beyond the point of tangency into the U-bend tube legs shall not exceed 1 in. [25 mm].

**12.2.6 Bending Radius**—The leg spacing, measured between the points of tangency of the bend to the legs shall not vary from the value ( $2R -$  specified tube outside diameter) by more than  $\frac{1}{16}$  in. [1.6 mm] where  $R$  is the specified centerline bend radius (Note 5).

**NOTE 5**—The higher tensile properties recognized by the ASME Code for Copper Alloy UNS No. C71500 or C71520 in the drawn, stress-relieved temper (HR50) and Copper UNS Nos. C10200, C10300, C10800, C12000, C12200, C14200, and Copper Alloy No. C70400 in the light-drawn temper (H55) are obtained with some sacrifice of ductility. Similarly, though the ASME Code does not recognize Copper Alloy UNS No. C70600 or C70620 in the light-drawn temper (H55), tubes in this temper are frequently required.

**NOTE 6**—The radius of the bend of tubes of C71500 or C71520, in the drawn stress-relieved temper (HR50), shall not be less than 2.2 times the tube outside diameter for tubes with 0.049-in. [1.24 mm] wall, and not less than two times the tube outside diameter for tubes with 0.058 in. [1.47 mm] wall.

**12.2.7 Diameter of Tube in U-Bent Section**—Neither the major, nor the minor outside diameter of the tube at any one cross section included within the points of tangency of the bend shall deviate from the nominal diameter prior to bending by more than 10 %.

**12.2.8 Length of U-Bend Tube Legs**—The length  $L$  in Fig. 1 of the tube legs as measured from the point of tangency of the bend and the tube leg to the end of the tube leg shall not be less than that specified when measured at a temperature of 68 °F [20 °C], but may exceed the specified values by the amounts shown in Table 13 for product specified in the inch-pound system or Table 14 for product specified in the SI system.

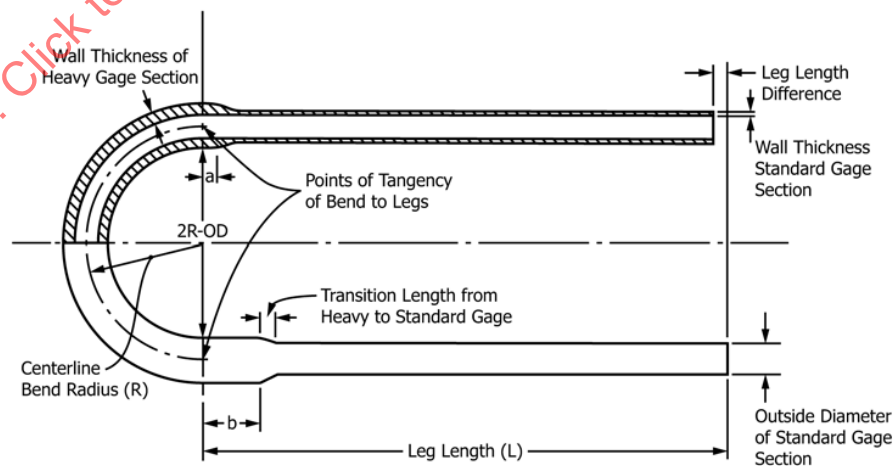

FIG. 1 Centering of U-Bend in Heavy Gage Section of Tube

TABLE 13 Tube Leg Tolerances

Specified Length, (L) ft	Tolerance all Plus, in.
Up to 20, incl	$\frac{1}{8}$
Over 20–30, incl	$\frac{5}{22}$
Over 30–60, incl	$\frac{1}{4}$
Over 60	$\frac{3}{8}$

TABLE 14 Tube Leg Tolerances (SI)

Specified Length, (L) mm	Tolerance all Plus, mm
Up to 6000, incl	3.2
Over 6000–9000, incl	4.0
Over 9000–18 000, incl	6.4
Over 18 000	9.5

12.2.8.1 The difference in length of the tube legs shall not be greater than  $\frac{1}{8}$  in. [3.2 mm], unless otherwise specified.

12.2.9 **Squareness of Cut**—The departure from squareness of the end of any tube shall not exceed the values given in Table 15 for product specified in the inch-pound system or Table 16 for product specified in the SI system. See Fig. 2.

### 13. Workmanship, Finish, and Appearance

13.1 The product shall be free of defects, but blemishes of a nature that do not interfere with the intended application are acceptable.

13.2 Annealed-temper (O61) tubes shall be clean and smooth, but may have a superficial, dull iridescent film on both the inside and outside surface. Drawn-temper tubes shall be clean and smooth, but may have a superficial film of drawing lubricant on the surfaces. A light oxide scale on the outside and inside surfaces of U-bend tubes shall be allowed for tubes which have been relief annealed.

### 14. Sampling

14.1 The lot size, portion size, and selection of pieces shall be as follows:

14.1.1 **Lot Size**—For purposes of testing, a lot shall consist of 600 tubes or fraction thereof, for tubes whose lengths prior to U-bending are up to and including 45 ft [13 800 mm] or 300

TABLE 15 Squareness Tolerances

Specified Outside Diameter, in.	Tolerance
Up to $\frac{5}{8}$ , incl	0.010 in.
Over $\frac{5}{8}$	0.016 in./in.

TABLE 16 Squareness Tolerances (SI)

Specified Outside Diameter, mm	Tolerance
Up to 16.0, incl	0.25 mm
Over 16.0	0.016 mm/mm

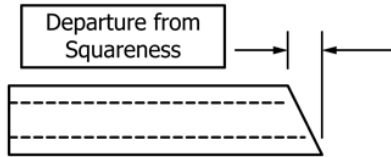

FIG. 2 Squareness of Cut

tubes or fraction thereof for tubes whose lengths prior to U-bending are over 45 ft [13 800 mm]. As tubes intended for U-bending are of different lengths depending on the bending radius, a lot of tubes for sampling purposes may include tubes of different lengths. If any order includes tubes whose lengths prior to bending are both under and over 45 ft [13 800 mm], those tubes shall be divided into separate lots as noted above.

14.1.2 *Portion Size*—Pieces from two tubes selected from each lot prior to bending.

#### 14.2 Chemical Analysis:

14.2.1 Samples for chemical analysis shall be taken in accordance with Practice E255. Drillings, millings, and so forth, shall be taken in approximately equal weight from each of the sample pieces selected in accordance with 14.1.2 and combined into one composite sample. The minimum weight of the composite sample that is to be divided into three equal parts shall be 0.33 lb [150 g].

14.2.1.1 Instead of sampling in accordance with Practice E255, the manufacturer shall have the option of determining conformance to chemical composition as follows: Conformance shall be determined by the manufacturer by analyzing samples taken at the time the castings are poured or samples taken from the semi-finished product. If the manufacturer determines the chemical composition of the material during the course of manufacture, he shall not be required to sample and analyze the finished product.

14.2.1.2 The number of samples taken for determination of chemical composition shall be as follows:

(a) When samples are taken at the time the castings are poured, at least one sample shall be taken for each group of castings poured simultaneously from the same source of molten metal.

(b) When samples are taken from the semi-finished product, a sample shall be taken to represent each 10 000 lb [4550 kg] or fraction thereof, except that not more than one sample shall be required per piece.

(c) Due to the discontinuous nature of the processing of castings into wrought products, it is not practical to identify specific casting analysis with a specific quantity of finished material.

(d) In the event that heat identification or traceability is required, the purchaser shall specify the details desired.

### 15. Number of Tests and Retests

#### 15.1 Test:

15.1.1 *Chemical Analysis*—One composite sample shall be subjected to the test as defined in 14.2.

15.1.2 *Grain Size*—Two tubes shall be selected from each lot prior to bending and each tube shall be tested to verify the requirements in Section 8.

15.1.3 *Tensile Property Requirements*—Two tubes shall be selected from each lot prior to bending and each tube shall be tested to verify the requirements in Section 9.

15.1.4 *Expansion Test*—Two tubes shall be selected from each lot prior to bending and each tube shall be tested to verify the requirements in Section 10.

15.1.5 *Flattening Test*—Two tubes shall be selected from each lot prior to bending and each tube shall be tested to verify the requirement in 10.2.

15.1.6 *Mercurous Nitrate Test or Ammonia Vapor Test*—The two sample lengths selected for test specimens in 14.1 shall be tested to verify the requirements of 10.3.1.

#### 15.2 Retest:

15.2.1 When requested by the manufacturer or supplier, a retest shall be permitted when results of tests obtained by the purchaser fail to conform to the requirements of the product specification.

15.2.2 The retest shall be as directed in the product specification for the initial test, except the number of test specimens shall be twice that normally required for the specified test.

15.2.3 All test specimens shall conform to the product specification requirement(s) in retest. Failure to conform shall be cause for rejection.

### 16. Specimen Preparation

#### 16.1 Chemical Analysis:

16.1.1 Sample preparation shall be in accordance with Practice E255.

16.1.2 Analytical specimen preparation shall be the responsibility of the reporting laboratory.

16.2 *Grain Size*—The test specimen shall be prepared in accordance with Guide E3 and shall approximate a longitudinal section of the tube.

#### 16.3 Tension Test:

16.3.1 Tension test specimens shall be of the full section of tube and shall conform to the requirements of the Test Specimen section of Test Methods E8/E8M, as applicable unless the limitations of the testing machine precludes the use of such a specimen. Test specimens conforming to Type No. 1 of Fig. 13, Tension Test Specimens for Large-Diameter Tubular Products, of Test Methods E8/E8M shall be used when a full section specimen cannot be tested.

16.3.2 Tension test results on product covered by this specification are not seriously affected by variations in speed of

testing. The rate of stressing to the yield strength shall not exceed 100 ksi/min [690 MPa/mm]. Above the yield strength, the movement per minute of the testing machine head under load should not exceed 0.5 in./in. [0.5 mm/mm], as appropriate of gage length (or distance between grips for full section specimens).

16.4 *Expansion Test Specimen*—Test specimens shall conform to the requirements of the Specimen Preparation section of Test Method B153.

16.5 *Mercurous Nitrate Test or Ammonia Vapor Test*:

16.5.1 A sufficient length of tube taken from each of the two sample lengths selected for test specimens (see 14.1) shall be U-bent to the smallest radius in the contract or purchase order and shall be subjected to the same relief-annealed (HR) treatment to be used for this size in producing the order.

16.5.2 The test specimens shall be cut 6 in. [150 mm] in length from both the U-bend and straight-leg length.

16.5.3 The straight-leg specimens shall include the finished-tube ends.

16.6 *Flattening Test*—A test specimen shall conform to the appropriate requirements of the Test Specimen section of Test Method B968/B968M.

## 17. Test Methods

17.1 *Chemical Composition*:

17.1.1 Chemical compositions for all other alloys, in case of disagreement, shall be determined as follows:

Element	Range	Test Method
Copper	99.75 to 99.99	E53, Electrolytic
Copper	70.0 to 99.75	E478, Electrolytic
Tin	0.9 to 1.2	E478, Photometric
Aluminum	1.8 to 6.5	E478
Nickel, incl Cobalt	4.8 to 33.0	E478, Gravimetric
Lead	0.05 to 0.10	E478, Atomic Absorption,
Iron	0.04 to 1.8	E478
Zinc	14.0 to 30.0	E478, Titrimetric
Zinc	to 1.0	E478, Atomic Absorption
Manganese	to 1.0	E62
Arsenic	0.02 to 0.5	E62
Antimony	0.02 to 0.1	E62
Phosphorus	0.001 to 0.04	E62
Chromium	0.30 to 0.70	E118
Oxygen	+0.0010	E2575

17.2 *Other Tests*:

17.2.1 The product furnished shall conform to all other requirements when subjected to testing in accordance with the following table:

Ammonia Vapor Test	B858
Eddy Current	E243
Expansion (Pin Test)	B153
Grain Size	E112
Mercurous Nitrate	B154
Tension	E8/E8M
Flattening	B968/B968M

17.2.1.1 *Grain Size*—In case of dispute, the intercept method of Test Methods E112 shall be followed.

17.2.1.2 *Tension Test*—Whenever tension test results are obtained from both full size and from machined test specimens and they differ, the results obtained from full-size specimens shall prevail.

## 18. Significance of Numerical Limits

18.1 For purpose of determining compliance with the specified limits for requirements of the properties listed in the following table, an observed value or a calculated value shall be rounded as indicated in accordance with the rounding method of Practice E29.

Property	Rounded Unit for Observed or Calculated Value
Chemical composition	nearest unit in the last right-hand significant digit used in expressing the limiting value
Tensile strength	nearest ksi [nearest 5 MPa]
Elongation	nearest 1 %
Expansion	nearest 1 %
Grain size	nearest multiple of 0.005 mm

## 19. Inspection

19.1 The manufacturer, or supplier, shall inspect and make necessary tests to verify that the furnished product conforms to the specification requirements.

19.2 Source inspection of the product by the purchaser may be agreed upon between the manufacturer, or supplier, and the purchaser as part of the purchase order. In such case, the nature of the facilities needed to satisfy the inspector, representing the purchaser, that the product is being furnished in accordance with the specification shall be included in the agreement. All testing and inspection shall be conducted so as not to interfere unnecessarily with the operation of the works.

19.3 When mutually agreed upon, the manufacturer, or supplier, and the purchaser shall conduct the final inspection simultaneously.

## 20. Rejection and Rehearing

20.1 *Rejection*:

20.1.1 Product that fails to conform to the requirements of this specification when inspected or tested by the purchaser, or purchaser's agent, shall be subject to rejection.

20.1.2 Rejection shall be reported to the manufacturer or supplier promptly. In addition, a written notification of rejection shall follow.

20.1.3 In case of dissatisfaction with results of the test upon which rejection is based, the manufacturer, or supplier, shall have the option to make claim for rehearing.

20.2 *Rehearing*:

20.2.1 As a result of product rejection, the manufacturer, or supplier, shall have the option to make claim for a retest to be conducted by the manufacturer, or supplier, and the purchaser. Samples of the rejected product shall be taken in accordance with the product specification and subjected to test by both

parties using the test method(s) specified in the product specification, or alternately, upon agreement of both parties, an independent laboratory may be selected for the test(s) using the test method(s) specified in the product specification.

## 21. Certification

21.1 When specified in the contract or purchase order, the purchaser shall be furnished certification that samples representing each lot have been either tested or inspected as directed in this specification and requirements have been met.

21.2 When specified in the purchase order or contract that product is purchased for *ASME Boiler and Pressure Vessel Code* applications, certification to the ASME specification is mandatory.

## 22. Mill Test Report

22.1 When specified in the contract or purchase order, a report of test results shall be furnished.

## 23. Packaging and Package Marking

### 23.1 Packaging:

23.1.1 The material shall be separated by size, composition, and temper, and prepared for shipment in such a manner as to ensure acceptance by common carrier for transportation and in such a manner to afford protection from the normal hazards of transportation.

### 23.2 Package Marking:

23.2.1 Each shipping unit shall be legibly marked with the purchase order number, metal or alloy designation, temper, size, shape, total length of piece count, or both, and name of supplier. The specification number shall be shown, when specified.

## 24. Keywords

24.1 condenser tube; copper; copper alloy; dual-gage; evaporator; heat exchanger; U-bend tube; C10200; C10300; C10800; C12000; C12200; C14200; C19200; C23000; C44300; C44400; C44500; C60800; C68700; C70400; C70600; C70620; C71000; C71500; C71520; C72200

## SUPPLEMENTARY REQUIREMENTS

The following supplementary requirements shall apply only when specified by the purchaser in the inquiry, contract, or order, for agencies of the U.S. Government.

### S1. Referenced Documents

S1.1 The following documents of the issue in effect on date of material purchase form a part of this specification to the extent referenced herein:

#### S1.1.1 *Federal Standards:*<sup>6</sup>

Fed. Std. No. 102 Preservation, Packaging and Packing Levels

Fed. Std. No. 123 Marking for Shipment (Civil Agencies)

Fed. Std. No. 185 Identification Marking of Copper and Copper-Base Alloy Mill Products

#### S1.1.2 *Military Standard:*<sup>6</sup>

MIL-STD-129 Marking for Shipment and Storage

#### S1.1.3 *ASTM Standard:*

B900 Practice for Packaging of Copper and Copper-Alloy Mill Products for U.S. Government Agencies

### S2. Quality Assurance

#### S2.1 *Responsibility for Inspection:*

S2.1.1 Unless otherwise specified in the contract or purchase order, the manufacturer is responsible for the performance of all inspection and test requirements specified. Except as otherwise specified in the contract or purchase order, the manufacturer may use his own or any other suitable facilities for the performance of the inspection and test requirements

unless disapproved of by the purchaser at the time the order is placed. The purchaser shall have the right to perform any of the inspections or tests set forth when such inspections and tests are deemed necessary to assure that the material conforms to prescribed requirements.

### S3. Identification Marking

S3.1 All material shall be properly marked for identification in accordance with Fed. Std. No. 185 except that the ASTM specification number and the alloy number shall be used.

### S4. Preparation for Delivery

#### S4.1 *Preservation, Packaging, Packing:*

S4.1.1 *Military Agencies*—The material shall be separated by size, composition, grade or class and shall be preserved and packaged, Level A or C, packed, Level A, B, or C as specified in the contract or purchase order, in accordance with the requirements of Practice B900.

S4.1.2 *Civil Agencies*—The requirements of Fed. Std. No. 102 shall be referenced for definitions of the various levels of packaging protection.

#### S4.2 *Marking:*

S4.2.1 *Military Agencies*—In addition to any special marking required by the contract or purchase order, marking for shipment shall be in accordance with MIL-STD-129.

S4.2.2 *Civil Agencies*—In addition to any special marking required by the contract or purchase order, marking for shipment shall be in accordance with Fed. Std. No. 123.

<sup>6</sup> DLA Document Services, Building 4/D, 700 Robbins Avenue, Philadelphia, PA 19111-5094, <http://quicksearch.dla.mil/>

## SUMMARY OF CHANGES

Committee B05 has identified the location of selected changes to this specification since the last issue (B395/B395M – 16) that may impact the use of this standard. (Approved March 1, 2018.)

(1) Restated inappropriately stated sizes in Table 7 to match the SI metric dimensions in Table 8.

Committee B05 has identified the location of selected changes to this specification since the last issue (B395/B395M – 13) that may impact the use of this standard. (Approved Oct. 1, 2016)

(1) Corrected typo in Table 4 where HR58 should be HR50. HR58 is not listed in Classification B601.

*ASTM International takes no position respecting the validity of any patent rights asserted in connection with any item mentioned in this standard. Users of this standard are expressly advised that determination of the validity of any such patent rights, and the risk of infringement of such rights, are entirely their own responsibility.*

*This standard is subject to revision at any time by the responsible technical committee and must be reviewed every five years and if not revised, either reapproved or withdrawn. Your comments are invited either for revision of this standard or for additional standards and should be addressed to ASTM International Headquarters. Your comments will receive careful consideration at a meeting of the responsible technical committee, which you may attend. If you feel that your comments have not received a fair hearing you should make your views known to the ASTM Committee on Standards, at the address shown below.*

*This standard is copyrighted by ASTM International, 100 Barr Harbor Drive, PO Box C700, West Conshohocken, PA 19428-2959, United States. Individual reprints (single or multiple copies) of this standard may be obtained by contacting ASTM at the above address or at 610-832-9585 (phone), 610-832-9555 (fax), or [service@astm.org](mailto:service@astm.org) (e-mail); or through the ASTM website ([www.astm.org](http://www.astm.org)). Permission rights to photocopy the standard may also be secured from the Copyright Clearance Center, 222 Rosewood Drive, Danvers, MA 01923, Tel: (978) 646-2600; <http://www.copyright.com/>*

ASMENORMDOC.COM : Click to view the full PDF of ASME BPVC.II.B (ASME BPVC Section II part B) 2025

INTENTIONALLY LEFT BLANK

# SPECIFICATION FOR NICKEL-IRON-CHROMIUM ALLOY SEAMLESS PIPE AND TUBE



**SB-407**

(Identical with ASTM Specification B407-08a(2019) except that paras. 4.1.6, 7.4 and Section X3 have been removed.)

ASMENORMDOC.COM : Click to view the full PDF of ASME BPVC.II.B (ASME BPVC Section II part B) 2025

# Specification for Nickel-Iron-Chromium Alloy Seamless Pipe and Tube

## 1. Scope

1.1 This specification covers UNS N08120, UNS N08800, UNS N08801, UNS N08810, UNS N08811, UNS N08890, and UNS N06811 in the form of cold-worked and hot-finished annealed seamless pipe and tube. Alloys UNS N08800 and UNS N06811 are normally employed in service temperatures up to and including 1100 °F (593 °C). Alloys UNS N08120, UNS N08810, UNS N08811, and UNS N08890 are normally employed in service temperatures above 1100 °F (593 °C) where resistance to creep and rupture is required, and they are annealed to develop controlled grain size for optimum properties in this temperature range.

1.2 The values stated in inch-pound units are to be regarded as standard. The values given in parentheses are mathematical conversions to SI units that are provided for information only and are not considered standard.

1.3 The following safety hazards caveat pertains only to the test method portion, Section 7, of this specification. *This standard does not purport to address all of the safety concerns, if any, associated with its use. It is the responsibility of the user of this standard to establish appropriate safety, health, and environmental practices and determine the applicability of regulatory limitations prior to use.*

1.4 *This international standard was developed in accordance with internationally recognized principles on standardization established in the Decision on Principles for the Development of International Standards, Guides and Recommendations issued by the World Trade Organization Technical Barriers to Trade (TBT) Committee.*

## 2. Referenced Documents

### 2.1 ASTM Standards:

B829 Specification for General Requirements for Nickel and Nickel Alloys Seamless Pipe and Tube

E140 Hardness Conversion Tables for Metals Relationship Among Brinell Hardness, Vickers Hardness, Rockwell Hardness, Superficial Hardness, Knoop Hardness, Scleroscope Hardness, and Leeb Hardness

## 3. General Requirements

3.1 Material furnished under this specification shall conform to the applicable requirements of Specification B829 unless otherwise specified herein.

## 4. Ordering Information

4.1 Orders for material to this specification should include information with respect to the following:

4.1.1 Alloy (Table 1).

4.1.2 Condition temper (Table 2 and Appendix X2).

4.1.3 Finish (Table X1.1).

4.1.4 *Dimensions:*

4.1.4.1 *Tube*—May be specified in two dimensions only (length excepted) as follows: outside diameter and average or minimum wall, inside diameter and average wall, or outside diameter and inside diameter.

NOTE 1—Tube produced to outside diameter and minimum wall may be furnished upon agreement between the manufacturer and the purchaser.

4.1.4.2 *Pipe*—Standard pipe size and schedule.

4.1.5 *Fabrication Details*—Not mandatory but helpful to the manufacturer:

4.1.5.1 Cold bending or coiling.

4.1.5.2 Hot forming.

4.1.5.3 *Welding or Brazing*—Process to be employed.

4.1.5.4 *Pressure Requirements*—Test pressure if other than required by 7.3.

4.1.5.5 *Machining*—Indicate finished size and length in which to be machined and whether to be chucked to outside diameter or inside diameter.

4.1.5.6 *Ends*—Plain ends cut and deburred will be furnished. If threaded ends or ends beveled for welding are desired, give details.

4.1.6 *Certification*—DELETED

4.1.7 *Samples for Product (Check) Analysis*—State whether samples for product (check) analysis should be furnished (6.2).

TABLE 1 Chemical Requirements

Element	Composition Limits, %				
	UNS N08120	UNS N08800, UNS N08810, and UNS N08811	UNS N08801	UNS N08890	UNS N06811
Nickel	35.0 min 39.0 max	30.0 min 35.0 max	30.0 min 34.0 max	40.0 min 45.0 max	38.0 min 46.0 max
Chromium	23.0 min 27.0 max	19.0 min 23.0 max	19.0 min 22.0 max	23.5 min 28.5 max	27.0 min 31.0 max
Iron	remainder	39.5 min <sup>A</sup>	39.5 min <sup>A</sup>	remainder	remainder
Manganese, max	1.5	1.5	1.5	1.5	2.0
Carbon	0.02 min 0.10 max	<sup>B</sup>	0.10 max	0.06 min 0.14 max	0.03 max
Copper, max	0.5	0.75	0.5	0.75	...
Silicon	1.0	1.0	1.0	1.0 min 2.0 max	0.60 max
Sulfur, max	0.03	0.015	0.015	0.015	0.010
Aluminum <sup>C</sup>	0.40 max	0.15 min 0.60 max	...	0.05 min 0.60 max	...
Titanium <sup>C</sup>	0.20 max	0.15 min 0.60 max	0.75 min 1.50 max	0.15 min 0.60 max	...
Columbium	0.4 min 0.9 max	...	...	...	...
Molybdenum	2.50 max	...	...	1.0 min 2.0 max	0.50 min 1.50 max
Niobium	...	...	...	0.2 min 1.0 max	...
Tantalum	...	...	...	0.10 min 0.60 max	...
Phosphorus	0.040 max	...	...	...	0.030 max
Tungsten	2.50 max	...	...	...	...
Cobalt, max	3.0	...	...	...	...
Nitrogen	0.15 min 0.30 max	...	...	...	0.10 min 0.20 max
Boron	0.010 max	...	...	...	...

<sup>A</sup> Iron shall be determined arithmetically by difference.

<sup>B</sup> Alloy UNS N08800: 0.10 max. Alloy UNS N08810: 0.05–0.10. Alloy UNS N08811: 0.06–0.10.

<sup>C</sup> Alloy UNS N08811: Al + Ti, 0.85–1.20.

TABLE 2 Mechanical Properties<sup>A</sup> of Pipe and Tube

Alloy	Condition (Temper)	Tensile Strength, min, psi (MPa)	Yield Strength, (0.2 % offset), min, psi (MPa)	Elongation in 2 in. or 50 mm (or 4D), min, %
UNS N08120	hot-finished annealed or cold-worked annealed	90 000 (621)	40 000 (276)	30
UNS N08800	cold-worked annealed	75 000 (520)	30 000 (205)	30
UNS N08800	hot-finished annealed or hot-finished	65 000 (450)	25 000 (170)	30
UNS N08810 and UNS N08811	hot-finished annealed or cold-worked annealed	65 000 (450)	25 000 (170)	30
UNS N08801	hot-finished annealed or cold-worked annealed	65 000 (450)	25 000 (170)	30
UNS N08890	hot-finished annealed or cold-worked annealed	75 000 (520)	30 000 (205)	35
UNS N06811	hot-finished annealed or cold-worked annealed	85 000 (585)	35 000 (240)	30

<sup>A</sup> DELETED.

4.1.8 *Purchaser Inspection*—If the purchaser wishes to witness tests or inspection of material at place of manufacture, the purchase order must so state indicating which tests or inspections are to be witnessed.

4.1.9 *Small-Diameter and Light-Wall Tube*—(Converter Sizes).

4.1.10 *Optional Requirement*—Hydrostatic or Nondestructive Electric Test (see 7.3).

## 5. Materials and Manufacture

5.1 *Heat Treatment*—The final heat treatment of UNS N08120 shall be 2150 °F (1177 °C) minimum, UNS N08810, 2050 °F (1121 °C) minimum, UNS N08811, UNS N08890, 2100 °F (1149 °C) minimum, and UNS N06811, 1920 °F (1050 °C) minimum.

## 6. Chemical Composition

6.1 The material shall conform to the composition limits specified in Table 1.

6.2 If a product (check) analysis is performed by the purchaser, the material shall conform to the product (check) analysis variations in Specification B829.

## 7. Mechanical Properties and Other Requirements

7.1 *Mechanical Properties*—The material shall conform to the mechanical properties specified in Table 2.

7.2 *Grain Size*—Annealed UNS alloys N08120, N08810, N08811, and UNS N08890 shall conform to an average grain size of ASTM No. 5 or coarser.

7.3 *Hydrostatic Test or Nondestructive Electric Test*—Each pipe or tube shall be subjected to either the hydrostatic test or the nondestructive electric test. The type of test to be used shall be at the option of the manufacturer, unless otherwise specified in the purchase order.

7.4 DELETED

**8. Dimensions and Permissible Variations**

8.1 *Diameter and Wall Thickness:*

8.1.1 The permissible variations in the outside and inside diameter and wall thickness of pipe and tube shall not exceed those prescribed in Table 3.

8.1.2 Permissible variations given in Table 3 are applicable only to two dimensions. Thus, if outside diameter and wall are specified, the inside diameter may not conform to the permissible variations shown. Similarly, if outside diameter and inside diameter are specified, the wall may not conform to the permissible variations shown.

8.2 *Length*—When pipe or tube is ordered cut to length, the length shall not be less than that specified, but a variation of +1/8 in. (3.2 mm) will be permitted for cold-worked material and +3/16 in. (4.8 mm) for hot-finished tube, except that for lengths over 30 ft (9.1 m), a variation of +1/4 in. (6.4 mm) will be permitted. For small-diameter and light-wall tube, material shall conform to the applicable requirements.

8.3 *Straightness*—Cold-drawn material shall be reasonably straight and free of bends and kinks. For small-diameter and light-wall tube, material shall conform to the applicable requirements. The camber (depth of chord) of hot-finished tube 5 in. (127 mm) in outside diameter and under shall not exceed 0.01 in./ft (0.8 mm/m). For sizes over 5 in. in outside diameter, the camber shall not exceed 0.015 in./ft (1.4 mm/m).

**9. Number of Tests**

9.1 *Chemical Analysis*—One test per lot.

9.2 *Mechanical Properties*—One test per lot.

**TABLE 3 Permissible Variations in Outside and Inside Diameter and Wall Thickness (Average Wall)**

Specified Outside Diameter or Calculated Nominal Outside Diameter (When Ordered to Inside Diameter and Average Wall)	Permissible Variations			
	Outside Diameter or Inside Diameter		Wall Thickness,%	
	+	-	+	-
	Cold-Finished <sup>A,B,C,D</sup> Pipe and Tube			
	Inches			
0.500 to 5/8, excl	0.005	0.005	15.0	15.0
5/8 to 1 1/2, incl	0.0075	0.0075	10.0	10.0
Over 1 1/2 to 3 1/2, incl	0.010	0.010	10.0	10.0
Over 3 1/2 to 4 1/2, incl	0.015	0.015	10.0	10.0
Over 4 1/2 to 6, incl	0.020	0.020	12.5	12.5
Over 6 to 6 5/8, incl	0.025	0.025	12.5	12.5
	Millimetres			
12.7 to 15.8, excl	0.127	0.127	15.0	15.0
15.8 to 38.1, incl	0.190	0.190	10.0	10.0
Over 38.1 to 88.9, incl	0.254	0.254	10.0	10.0
Over 88.9 to 114.3, incl	0.381	0.381	10.0	10.0
Over 114.3 to 152.4, incl	0.508	0.508	12.5	12.5
Over 152.4 to 168.3, incl	0.635	0.635	12.5	12.5
	Hot-Finished Tube <sup>E,F,G,H</sup>			
	Inches			
2 1/2 to 5 1/2, excl	0.031	0.031	12.5	12.5
5 1/2 to 9 1/4, incl	0.047	0.047	12.5	12.5
	Millimetres			
63.5 to 139.7, excl	0.787	0.787	12.5	12.5
139.7 to 234.9, incl	1.19	1.19	12.5	12.5

<sup>A</sup> The permissible variations in this table apply to individual measurements, including out-of-roundness (ovality), except for the following conditions.  
 1) *Thin-Wall Pipe and Tube*—For thin-wall pipe and tube having a nominal wall thickness of 3 % or less of the nominal outside diameter, in all conditions (temper), the mean outside diameter or mean inside diameter shall conform to the permissible variations of this table, and individual measurements (including ovality) shall conform to the plus and minus values of this table, with the values increased by 0.5 % of the nominal outside diameter.  
 2) *Annealed Pipe and Tube Over 4 1/2 in. (114.3 mm) in Nominal Outside Diameter*—For annealed pipe and tubing over 4 1/2 in. (114.3 mm) in nominal outside diameter with a nominal wall thickness greater than 3 % of the nominal outside diameter, the mean outside diameter or mean inside diameter shall conform to the permissible variations of this table, and individual measurements shall not exceed twice the permissible variations of this table.  
<sup>B</sup> For pipe and tube, in all tempers, with an inside diameter of less than 1/2 in. (12.70 mm) which cannot be successfully drawn over a mandrel, the inside diameter shall be governed by the outside diameter and the wall thickness variations.  
<sup>C</sup> For pipe and tube in all tempers with an inside diameter less than 50 % of the outside diameter, which cannot be successfully drawn over a mandrel, the inside diameter may vary over or under by an amount equal to 10 % of the nominal wall thickness and the wall thickness may vary ±15 %.  
<sup>D</sup> *Eccentricity*—The variation in wall thickness in any one cross section of any one cold-finished pipe or tube shall not exceed ±10 % of the actual (measured) average wall of that section (defined as the average of the thickest and the thinnest wall in that section).  
<sup>E</sup> For tube 5 in. (127.0 mm) and under in outside diameter the tolerance on the outside diameter applies for individual measurements and includes ovality. For tubes over 5 in. (127.0 mm) in outside diameter the mean outside diameter shall conform to the permissible variations of this table and individual measurements shall not exceed twice the permissible variations of this table.  
<sup>F</sup> The diameter tolerances for tube with machined outside and inside diameters shall be +0.031 in. (0.787 mm), -0 for the outside diameter and +0, -0.062 in. (1.57 mm) for the inside diameter.  
<sup>G</sup> If tube is specified as minimum wall, the tolerance shall be +28.5 %, -0.  
<sup>H</sup> The wall thickness tolerance includes eccentricity tolerance up to ±12.5 %.

9.3 Grain Size—One test per lot.

9.4 Hydrostatic or Nondestructive Electric Test—Each piece per lot.

**10. Keywords**

10.1 seamless pipe; seamless tube; UNS N08120; UNS N08800; UNS N08801; UNS N08810; UNS N08811; UNS N08890; UNS N06811

**APPENDIXES**

(Nonmandatory Information)

**X1. SCHEDULES OF COLD-DRAWN, SEAMLESS NICKEL-IRON-CHROMIUM ALLOY PIPE**

X1.1 The schedules of cold-worked, seamless nickel-iron-chromium alloy pipe as given in Table X1.1 are regularly available. Other schedules may be furnished, and the manufacturer should be consulted. Table X1.1 is published for information only.

**TABLE X1.1 Pipe Schedules<sup>A</sup>**

Nominal Pipe Size	Outside Diameter	Nominal Wall Thickness			
		Schedule No. 5	Schedule No. 10	Schedule No. 40	Schedule No. 80
Inches					
¼	0.540	...	0.065	0.088	...
⅜	0.675	...	0.065	0.091	0.126
½	0.840	0.065	0.083	0.109	0.147
¾	1.050	0.065	0.083	0.113	0.154
1	1.315	0.065	0.109	0.133	0.179
1¼	1.660	0.065	0.109	0.140	0.191
1½	1.900	0.065	0.109	0.145	0.200
2	2.375	0.065	0.109	0.154	0.218
2½	2.875	0.083	0.120	0.203	0.276
3	3.500	0.083	0.120	0.216	0.300
3½	4.000	0.083	0.120	0.226	0.318
4	4.500	0.083	0.120	0.237	0.337
5	5.563	...	...	0.258	...
6	6.625	...	...	0.280	...
Millimetres					
6.35	13.72	...	1.65	2.24	...
9.52	17.14	...	1.65	2.31	3.20
12.70	21.34	1.65	2.11	2.77	3.73
19.05	26.67	1.65	2.11	2.87	3.91
25.4	33.40	1.65	2.77	3.38	4.55
31.8	42.16	1.65	2.77	3.56	4.85
38.1	48.26	1.65	2.77	3.68	5.08
50.8	60.32	1.65	2.77	3.91	5.54
63.5	73.02	2.11	3.05	5.16	7.04
76.2	88.90	2.11	3.05	5.49	7.62
88.9	101.60	2.11	3.05	5.74	8.08
101.6	114.30	2.11	3.05	6.02	8.56
127.0	141.30	...	...	6.55	...
152.4	168.28	...	...	7.11	...

<sup>A</sup> The pipe schedules shown above conform with standards adopted by the American National Standards Institute.

## X2. CONDITIONS AND FINISHES NORMALLY SUPPLIED

X2.1 This appendix lists the conditions and finishes in which pipe and tube (other than converter sizes) are normally supplied. These are subject to change, and the manufacturer should be consulted for the latest information available.

### X2.2 *Cold-Finished Tube and Pipe:*

X2.2.1 *Cold-Finished, Annealed, with Ground Outside Diameter*—The inside diameter may have a bright finish when material is annealed in a protective atmosphere; otherwise, the inside diameter is supplied descaled as necessary. Available in sizes  $\frac{1}{2}$  to 4 in. (12.7 to 102 mm), inclusive, in outside diameter in both normal and heavy-wall tube, and pipe sizes, all schedules, of corresponding outside diameter dimensions.

X2.2.2 *Cold-Finished, Annealed, and Pickled (Not Ground)*—Outside and inside diameter will have dull, matte (pickled) surfaces. Available in sizes  $\frac{1}{2}$  to  $6\frac{5}{8}$  in. (12.7 to 168 mm), inclusive, in outside diameter in both normal and

heavy-wall tube, and pipe sizes, all schedules, of corresponding outside diameter dimensions.

### X2.3 *Hot-Finished Tube:*

X2.3.1 *Hot-Finished, or Hot-Finished Annealed (Not Pickled) Tube*—Has an oxide surface resulting from the hot-finishing operation. Intended generally for machined parts where the oxide surface will be removed.

X2.3.2 *Hot-Finished, or Hot-Finished Annealed (Pickled) Tube*—Has the oxide surface removed on both outside and inside diameters by pickling. Surface may be spot ground for removal of minor surface imperfections at the manufacturer's option.

X2.3.3 *Hot-Finished, or Hot-Finished Annealed (Machined Outside and Inside Diameters) Tube*—The outside and inside diameter surfaces are machined to specified dimensions. Minor surface imperfections may be spot ground for removal, at the manufacturer's option.

## X3. DELETED

ASME BPVC Section II Part B) 2025  
Click to view the full PDF of ASME BPVC.II.B (ASME BPVC Section II Part B) 2025  
ASMENORMDOC.COM

# SPECIFICATION FOR NICKEL-IRON-CHROMIUM ALLOY ROD AND BAR



**SB-408**

(Identical with ASTM Specification B408-06(2011) except that certification and a test report have been made mandatory.)

ASMENORMDOC.COM : Click to view the full PDF of ASME BPVC.II.B (ASME BPVC Section II part B) 2025

# Standard Specification for Nickel-Iron-Chromium Alloy Rod and Bar

## 1. Scope

1.1 This specification covers UNS N08120, UNS N08800, UNS N08810, UNS N08811, and UNS N08890 in the form of hot-worked and cold-worked rod and bar. Alloy UNS N08800 is normally employed in service temperatures up to and including 1100°F (593°C). Alloys UNS N08120, UNS N08810, UNS N08811, and UNS N08890 are normally employed in service temperatures above 1100°F (593°C) where resistance to creep and rupture is required, and they are annealed to develop controlled grain size for optimum properties in this temperature range.

1.2 The values stated in inch-pound units are to be regarded as standard. The values given in parentheses are mathematical conversions to SI units that are provided for information only and are not considered standard.

1.3 *This standard does not purport to address all of the safety concerns, if any, associated with its use. It is the responsibility of the user of this standard to become familiar with all hazards including those identified in the appropriate Material Safety Data Sheet (MSDS) for this product/material as provided by the manufacturer, to establish appropriate safety and health practices, and determine the applicability of regulatory limitations prior to use.*

## 2. Referenced Documents

### 2.1 ASTM Standards:

B880 Specification for General Requirements for Chemical Check Analysis Limits for Nickel, Nickel Alloys and Cobalt Alloys  
E8 Test Methods for Tension Testing of Metallic Materials

E29 Practice for Using Significant Digits in Test Data to Determine Conformance with Specifications  
E112 Test Methods for Determining Average Grain Size  
E1473 Test Methods for Chemical Analysis of Nickel, Cobalt, and High-Temperature Alloys

## 3. Terminology

### 3.1 Definitions of Terms Specific to This Standard:

3.1.1 *bar, n*—material of rectangular (flats), hexagonal, or square solid section up to and including 10 in. (254 mm) in width and 1/8 in. (3.2 mm) and over in thickness in straight lengths.

3.1.1.1 *Discussion*—Hot-worked rectangular bar in widths 10 in. (254 mm) and under may be furnished as hot-rolled plate with sheared or cut edges in accordance with Specification B408, provided the mechanical property requirements of Specification B408 are met.

3.1.2 *rod, n*—material of round solid section furnished in straight lengths.

## 4. Ordering Information

4.1 Orders for material to this specification should include information with respect to the following:

4.1.1 ASTM designation, and year of issue.

4.1.2 Alloy designation or UNS number.

4.1.3 *Section*—Rod (round) or bar (square, hexagonal, or rectangular).

4.1.4 *Dimensions*—Dimensions including length (Section 8, Tables 1-4 incl).

4.1.5 *Condition* (Table 5 and Appendix X1).

4.1.6 *Finish* (Appendix X1).

4.1.7 *Quantity* (feet or number of pieces).

4.1.8 *Certification*—Certification and a report of test results (Section 16).

4.1.9 *Samples for Product (Check) Analysis*—State whether samples for product (check) analysis should be furnished.

4.1.10 *Purchaser Inspection*—If purchaser wishes to witness tests or inspection of material at place of manufacture, the purchase order must so state indicating which test or inspections are to be witnessed.

## 5. Materials and Manufacture

5.1 *Heat Treatment*—The final heat treatment of UNS N08120 shall be 2150°F (1177°C) minimum, UNS N08810,

**TABLE 1 Permissible Variations in Diameter or Distance Between Parallel Surfaces of Cold-Worked Rod and Bar**

Specified Dimension, in. (mm) <sup>A</sup>	Permissible Variations from Specified Dimension, in. (mm)	
	+	-
<b>Rounds:</b>		
1/16 (1.6) to 3/16 (4.8), excl	0	0.002 (0.05)
3/16 (4.8) to 1/2 (12.7), excl	0	0.003 (0.08)
1/2 (12.7) to 15/16 (23.8), incl	0.001 (0.03)	0.002 (0.05)
Over 15/16 (23.8) to 115/16 (49.2), incl	0.0015 (0.04)	0.003 (0.08)
Over 115/16 (49.2) to 2 1/2 (63.5), incl	0.002 (0.05)	0.004 (0.10)
<b>Hexagons, squares, rectangles:</b>		
1/2 (12.7) and less	0	0.004 (0.10)
Over 1/2 (12.7) to 7/8 (22.2), incl	0	0.005 (0.13)
Over 7/8 (22.2) to 1 1/4 (31.8), incl	0	0.007 (0.18)
Over 1 1/4 (31.8) to 2 (50.8), incl	0	0.009 (0.23)

<sup>A</sup> Dimensions apply to diameter of rounds, to distance between parallel surfaces of hexagons and squares, and separately to width and thickness of rectangles.

**TABLE 2 Permissible Variations in Diameter or Distance**

Specified Dimension, in. (mm) <sup>A</sup>	Permissible Variations from Specified Dimensions, in. (mm)	
	+	-
<b>Rod and bar, hot-worked:</b>		
1 (25.4) and under	0.016 (0.41)	0.016 (0.41)
Over 1 (25.4) to 2 (50.8), incl	0.031 (0.79)	0.016 (0.41)
Over 2 (50.8) to 4 (101.6), incl	0.047 (1.19)	0.031 (0.79)
Over 4 (101.6)	0.125 (3.18)	0.063 (1.60)
<b>Rod, rough turned or ground:</b>		
Under 1 (25.4)	0.005 (0.13)	0.005 (0.13)
1 (25.4) and over	0.031 (0.79)	0
<b>Forging quality rod:<sup>B</sup></b>		
Under 1 (25.4)	0.005 (0.13)	0.005 (0.13)
1 (25.4) and over	0.031 (0.79)	0

<sup>A</sup> Dimensions apply to diameter of rods, to distance between parallel surfaces of hexagons and squares, and separately to width and thickness of rectangles.

<sup>B</sup> Spot grinding is permitted to remove minor surface imperfections. The depth of these spot ground areas shall not exceed 3% of the diameter of the rod.

2050°F (1121°C) minimum, UNS N08811, and UNS N08890, 2100°F (1149°C) minimum.

## 6. Chemical Composition

6.1 The material shall conform to the composition limits specified in Table 6.

6.2 If a product (check) analysis is performed by the purchaser, the material shall conform to the product (check) analysis variations in Specification B880.

## 7. Mechanical Properties and Other Requirements

7.1 *Mechanical Properties*—The material shall conform to the mechanical properties specified in Table 5.

7.2 *Grain Size*—Annealed UNS Alloys N08120, N08810, N08811, and N08890 shall conform to an average grain size of ASTM No. 5 or coarser.

## 8. Dimensions and Permissible Variations

8.1 *Diameter, Thickness, or Width*—The permissible variations from the specified dimensions as measured on the diameter or between parallel surfaces of cold-worked rod and

bar shall be as prescribed in Table 1, and of hot-worked rod and bar as prescribed in Table 2.

8.2 *Out-of-Round*—Hot-worked rods and cold-worked rods (except “forging quality”) all sizes, in straight lengths, shall not be out-of-round by more than one half the total permissible variations in diameter shown in Table 1 and Table 2, except for hot-worked rods 1/2 in. (12.7 mm) in diameter and under, which may be out-of-round by the total permissible variations in diameter shown in Table 2.

8.3 *Corners*—Cold-worked bars will have practically exact angles and sharp corners.

8.4 *Machining Allowances for Hot-Worked Materials*—When the surfaces of hot-worked products are to be machined, the allowances prescribed in Table 3 are recommended for normal machining operations.

8.5 *Length*—The permissible variations in length of cold-worked and hot-worked rod and bar shall be as prescribed in Table 4.

8.5.1 Rods and bars ordered to random or nominal lengths will be furnished with either cropped or saw-cut ends; material ordered to cut lengths will be furnished with square saw-cut or machined ends.

### 8.6 Straightness:

8.6.1 The permissible variations in straightness of cold-worked rod and bar as determined by the departure from straightness shall be as prescribed in Table 7.

8.6.2 The permissible variations in straightness of hot-worked rod and bar as determined by the departure from straightness shall be as specified in Table 8.

## 9. Workmanship, Finish, and Appearance

9.1 The material shall be uniform in quality and condition, smooth, commercially straight or flat, and free of injurious imperfections.

## 10. Sampling

### 10.1 Lot:

10.1.1 A lot for chemical analysis shall consist of one heat.

10.1.2 A lot for mechanical properties and grain size testing shall consist of all material from the same heat, nominal diameter or thickness, and condition.

10.1.2.1 Where material cannot be identified by heat, a lot shall consist of not more than 500 lb (227 kg) of material in the same size and condition except that a single piece weighing over 500 lb shall be considered as one lot.

### 10.2 Test Material Selection:

10.2.1 *Chemical Analysis*—Representative samples from each lot shall be taken during pouring or subsequent processing.

10.2.1.1 Product (check) analysis shall be wholly the responsibility of the purchaser.

10.2.2 *Mechanical Properties and Grain Size*—Samples of the material to provide test specimens for mechanical properties shall be taken from such locations in each lot as to be representative of that lot.

TABLE 3 Normal Machining Allowances for Hot-worked Material

Finished-Machined Dimensions for Finishes as Indicated Below, in. (mm) <sup>A</sup>	Normal Machining Allowance, in. (mm)			
	On Diameter, for Rods	Distance Between Parallel Surfaces, for Hexagonal and Square Bar	For Rectangular Bar	
			On Thickness	On Width
Hot-worked: <sup>B</sup>				
Up to 7/8 (22.2), incl	1/8 (3.2)	1/8 (3.2)	1/8 (3.2)	3/16 (4.8)
Over 7/8 to 1 1/8 (22.2 to 47.6), incl	1/8 (3.2)	3/16 (4.8)	1/8 (3.2)	3/16 (4.8)
Over 1 1/8 to 2 1/8 (47.6 to 73.0), incl	3/16 (4.8)	1/4 (6.4)	...	3/16 (4.8)
Over 2 1/8 to 3 1/16 (73.0 to 96.8), incl	1/4 (6.4)	...	...	3/16 (4.8)
Over 3 1/16 (96.8)	1/4 (6.4)	...	...	3/8 (9.5)
Hot-worked rods:				
Rough-turned or Rough Ground: <sup>C</sup>				
1 5/16 to 4 (23.8 to 101.6), incl in diameter	1/16 (1.6)	...	...	...
Over 4 to 12 (101.6 to 304.8), incl in diameter	1/8 (3.2)	...	...	...

<sup>A</sup> Dimensions apply to diameter of rods, to distance between parallel surfaces of hexagonal and square bar, and separately to width and thickness of rectangular bar.  
<sup>B</sup> The allowances for hot-worked material in Table 5 are recommended for rods machined in lengths of 3 ft (0.91 m) or less and for bars machined in lengths of 2 ft (0.61 m) or less. Hot-worked material to be machined in longer lengths should be specified showing the finished cross-sectional dimension and the length in which the material will be machined in order that the manufacturer may supply material with sufficient oversize, including allowance for out-of-straightness.  
<sup>C</sup> Applicable to 3 ft (0.91 m) max length.

TABLE 4 Permissible Variations in Length of Rods and Bars

Random mill lengths:	
Hot-worked	6 to 24 ft (1.83 to 7.31 m) long with not more than 25 weight % between 6 and 9 ft (1.83 and 2.74 m) <sup>A</sup>
Cold-worked	6 to 20 ft (1.83 to 6.1 m) long with not more than 25 weight % between 6 and 10 ft (1.83 and 3.05 m).
Multiple lengths	furnished in multiples of a specified unit length, within the length limits indicated above. For each multiple, an allowance of 1/4 in. (6.4 mm) will be made for cutting, unless otherwise specified. At the manufacturer's option, individual specified unit lengths may be furnished.
Nominal lengths	specified nominal lengths having a range of not less than 2 ft (610 mm) with no short lengths allowed <sup>B</sup>
Cut lengths	a specified length to which all rods and bars will be cut with a permissible variation of plus 1/8 in. (3.2 mm), minus 0 for sizes 8 in. (203 mm) and less in diameter or distance between parallel surfaces. For larger sizes, the permissible variation shall be + 1/4 in. (6.4 mm), - 0.

<sup>A</sup> For hot-worked sections weighing over 25 lb/ft (37 kg/m) and for smooth forged products, all sections, short lengths down to 2 ft (610 mm) may be furnished.  
<sup>B</sup> For cold-worked rods and bars under 1/2 in. (12.7 mm) in diameter or distance between parallel surfaces ordered to nominal or stock lengths with a 2-ft (610-mm) range, at least 93 % of such material shall be within the range specified; the balance may be in shorter lengths but in no case shall lengths less than 4 ft (1220 mm) be furnished.

TABLE 5 Mechanical Properties of Rods and Bars

Alloy	Condition	Tensile Strength, min, psi (MPa)	Yield Strength (0.2 % offset) min, psi (MPa)	Elongation in 2 in. or 50 mm (or 4D), min, %
UNS N08120	Cold-worked and hot-worked, annealed	90 000 (621)	40 000 (276)	30
UNS N08800	Hot worked, as-hot-worked	80 000 (550)	35 000 (240)	25 <sup>A</sup>
	Cold-worked and hot-worked, annealed	75 000 (515)	30 000 (205)	30
UNS N08810 and UNS N08811	Cold-worked and hot-worked, annealed	65 000 (450)	25 000 (170)	30
UNS N08890	Cold-worked and hot-worked, annealed	75 000 (520)	30 000 (205)	35
UNS N08800, UNS N08810 and UNS N08811	Forging quality	<sup>B</sup>	<sup>B</sup>	<sup>B</sup>

<sup>A</sup> For hot-worked as-hot-worked rectangular bar 3/16 in. (7.94 mm) and under in thickness the elongation shall be 20 % min.  
<sup>B</sup> Forging quality is furnished to chemical requirements and surface inspection only. No tensile properties are required.

11. Number of Tests

- 11.1 Chemical Analysis—One test per lot.
- 11.2 Tension—One test per lot.
- 11.3 Grain Size—One test per lot.

12. Specimen Preparation

12.1 Tension test specimens shall be taken from material in the final condition and tested in the direction of fabrication.  
 12.1.1 All rod and bar shall be tested in full cross-section size when possible. When a full cross-section size test cannot be performed, the largest possible round specimen shown in Test Methods E8 shall be used. Longitudinal strip specimens shall be prepared in accordance with Test Methods E8 for

rectangular bar up to 1/2 in. (12.7 mm), inclusive, in thicknesses which are too wide to be pulled full size.

13. Test Method

13.1 The chemical composition, mechanical, and other properties of the material as enumerated in this specification shall be determined, in case of disagreement, in accordance with the following methods:

Test	ASTM Designation
Chemical Analysis	E1473
Tension	E8
Rounding Procedure	E29
Grain Size	E112

TABLE 6 Chemical Requirements<sup>†</sup>

Element	Composition Limits, %				
	Alloy N08120	Alloy N08800	Alloy N08810	Alloy N08811	Alloy N08890
Nickel	35.0 min 39.0 max	30.0 min 35.0 max	30.0 min 35.0 max	30.0 min 35.0 max	40.0 min 45.0 max
Chromium	23.0 min 27.0 max	19.0 min 23.0 max	19.0 min 23.0 max	19.0 min 23.0 max	23.5 min 28.5 max
Iron	remainder	39.5 min <sup>A</sup>	39.5 min <sup>A</sup>	39.5 min <sup>A</sup>	remainder
Manganese, max	1.5	1.5	1.5	1.5	1.5
Carbon	0.02 min 0.10 max	0.10 max ...	0.05 to 0.10 ...	0.06 to 0.10 ...	0.06 min 0.14 max
Copper, max	0.50	0.75	0.75	0.75	0.75
Silicon	1.0	1.0	1.0	1.0	1.0 min 2.0 max
Sulfur, max	0.03	0.015	0.015	0.015	0.015
Aluminum <sup>B</sup>	0.40 max	0.15 min 0.60 max	0.15 min 0.60 max	0.15 min 0.60 max	0.05 min 0.60 max
Titanium <sup>B</sup>	0.20 max	0.15 min 0.60 max	0.15 min 0.60 max	0.15 min 0.60 max	0.15 min 0.60 max
Columbium	0.4 min 0.9 max	...	...	...	...
Molybdenum	2.50 max	...	...	...	1.0 min 2.0 max
Niobium	...	...	...	...	0.2 min 1.0 max
Tantalum	...	...	...	...	0.10 min 0.60 max
Phosphorus	0.040 max	...	...	...	...
Tungsten	2.50 max	...	...	...	...
Cobalt, max	3.0	...	...	...	...
Nitrogen	0.15 min 0.30 max	...	...	...	...
Boron	0.010 max	...	...	...	...

<sup>A</sup> Iron shall be determined arithmetically by difference.

<sup>B</sup> Alloy UNS N08811: Al + Ti, 0.85–1.20.

<sup>†</sup> Editorially corrected.

TABLE 7 Permissible Variations in Straightness of Cold-Worked Rods and Bars

Specified Diameter or Distance Between Parallel Surfaces, in. (mm) <sup>A</sup>	Depth of Chord, Permissible Variations in Lengths Indicated, in. (mm)
Rounds: ½ (12.7) to 2½ (63.5), incl	0.030 (0.76) per ft (305 mm) of length
Hexagons, squares, rectangles: ½ (12.7) to 2 (50.8), incl	0.030 (0.76) per ft (305 mm) of length

<sup>A</sup> Material under ½ in. (12.7 mm) shall be reasonably straight and free of sharp bends and kinks.

TABLE 8 Permissible Variations in Straightness of Hot-Worked Rods and Bars<sup>A</sup>

Finish	Permissible Variations, in./ft.(mm/m) <sup>B</sup>
Rods and bars, hot-worked	0.050 (4.2) <sup>C</sup>
Rounds: hot-worked, rough ground, or rough turned	0.050 (4.2) <sup>C</sup>

<sup>A</sup> Not applicable to forging quality.

<sup>B</sup> Material under ½ in. (12.7 mm) shall be reasonably straight and free of sharp bends and kinks.

<sup>C</sup> The maximum curvature (depth of chord) shall not exceed the values indicated multiplied by the length in feet.

13.2 In the event of disagreement, the referee method for the determination of average grain size shall be the planimetric method.

13.3 For purposes of determining compliance with the specified limits for requirements of the properties listed in the

following table, an observed value or a calculated value shall be rounded as indicated below, in accordance with the rounding method of Practice E29:

Test	Rounded Unit for Observed Or Calculated Value
Chemical composition, hardness, and tolerances (when expressed in decimals)	nearest unit in the last right-hand place of figures of the specified limit. If two choices are possible, as when the digits dropped are exactly a 5, or a 5 followed only by zeros, choose the one ending in an even digit, with zero defined as an even digit.
Tensile strength and yield strength	nearest 1000 psi (6.9 MPa)
Elongation	nearest 1 %

#### 14. Inspection

14.1 Inspection of the material shall be made as agreed upon between the manufacturer and the purchaser as part of the purchase contract.

#### 15. Rejection and Rehearing

15.1 Material, tested by the purchaser, that fails to conform to the requirements of this specification may be rejected. Rejection should be reported to the producer or supplier promptly and in writing. In case of dissatisfaction with the results of the test, the producer or supplier may make claim for a rehearing.

#### 16. Certification

16.1 A manufacturer's certification shall be furnished to the purchaser stating that material has been manufactured, tested, and inspected in accordance with this specification, and that the test results on representative samples meet specification requirements. A report of the test results shall be furnished.

#### 17. Product Marking

17.1 The following information shall be marked on the material or included on the package, or on a label or tag attached thereto: The name of the material or UNS Number, heat number, condition (temper), this specification number, date of issue, the size, gross, tare and net weight, consignor and consignee address; contract or order number, or such other information as may be defined in the contract or order.

#### 18. Keywords

18.1 bar; rod; UNS N08120; UNS N08800; UNS N08801; UNS N08810; UNS N08811; UNS N08890

### APPENDIX

#### (Nonmandatory Information)

#### X1. PROCURABLE CONDITIONS AND FINISHES

X1.1 The various conditions and finishes in which rod and bar are procurable are as follows:

X1.1.1 *Hot-Worked*—With a tightly adherent, dark oxide surface.

X1.1.2 *Hot-Worked, Rough Ground*—Similar to X1.1.1 except rough ground.

X1.1.3 *Hot-Worked, Rough-Turned*—Similar to X1.1.1 except rough turned with a broad nosed tool similar to a bar peeling operation and thus may not be straight. Intended generally for machining where an overhauled surface is desired, essentially for machined step down shafts or parts machined in short lengths of 3 ft (0.91 m) or less.

X1.1.4 *Hot-Worked, Forging Quality*—Rough turned and spot ground, as necessary, for sizes 1 in. (25.4 mm) in diameter and over; rough ground and spot ground for sizes under 1 in. in diameter. Material is selected from heats of known, good hot malleability.

NOTE X1.1—For sizes 2½ in. (63.5 mm) in diameter and less, cold-worked rod may be used also for forging by virtue of the fact such rod have been overhauled for removal of mechanical surface defects prior to cold-working. In such cases, the user should run pilot forging tests to ensure himself that such material has the desired hot malleability range.

X1.1.5 *Hot-Worked, Annealed*—Soft, with a tightly adherent dark oxide.

X1.1.6 *Hot-Worked, Annealed and Pickled*—Same as X1.1.5 except descaled for removal of mill oxide. Provides for better surface inspection than does hot-worked material and often employed where welding is involved where removal of mill oxide is desired.

NOTE X1.2—Annealing prior to pickling may be required in order to reduce the mill oxide since uniform pickling of an unreduced oxide is difficult.

X1.1.7 *Cold-Worked, As Worked*—Hot-worked, overhauled, cold worked, and straightened with a smooth, bright finish.

X1.1.8 *Cold-Worked, Annealed and Pickled*—Hotworked, overhauled, cold-worked, annealed, descaled, and straightened. Annealed for softness and with a dull matte finish.

# SPECIFICATION FOR NICKEL-IRON-CHROMIUM ALLOY PLATE, SHEET, AND STRIP



**SB-409**

(Identical with ASTM Specification B409-06(2011) except that certification and a test report have been made mandatory.)

ASMENORMDOC.COM : Click to view the full PDF of ASME BPVC.II.B (ASME BPVC Section II part B) 2025

# Standard Specification for Nickel-Iron-Chromium Alloy Plate, Sheet, and Strip

## 1. Scope

1.1 This specification covers UNS N08120, UNS N08890, UNS N08800, UNS N08810, and UNS N08811 in the form of rolled plate, sheet, and strip. Alloy UNS N08800 is normally employed in service temperatures up to and including 1100°F (593°C). Alloys UNS N08120, UNS N08810, UNS N08811, and UNS N08890 are normally employed in service temperatures above 1100°F (593°C) where resistance to creep and rupture is required, and they are annealed to develop controlled grain size for optimum properties in this temperature range.

1.2 The values stated in inch-pound units are to be regarded as standard. The values given in parentheses are mathematical conversions to SI units that are provided for information only and are not considered standard.

1.3 *This standard does not purport to address all of the safety concerns, if any, associated with its use. It is the responsibility of the user of this standard to become familiar with all hazards including those identified in the appropriate Material Safety Data Sheet (MSDS) for this product/material as provided by the manufacturer, to establish appropriate safety and health practices, and determine the applicability of regulatory limitations prior to use.*

## 2. Referenced Documents

### 2.1 ASTM Standards:

B408 Specification for Nickel-Iron-Chromium Alloy Rod and Bar

B906 Specification for General Requirements for Flat-Rolled Nickel and Nickel Alloys Plate, Sheet, and Strip

E140 Hardness Conversion Tables for Metals Relationship

Among Brinell Hardness, Vickers Hardness, Rockwell Hardness, Superficial Hardness, Knoop Hardness, and Scleroscope Hardness

F155 Method of Test for Temper of Strip and Sheet Metals for Electronic Devices (Spring-Back Method) (Withdrawn 1982)

## 3. Terminology

3.1 *Definitions of Terms Specific to This Standard*—The terms given in Table 1 shall apply.

## 4. General Requirements

4.1 Material furnished under this specification shall conform to the applicable requirements of Specification B906 unless otherwise provided herein.

## 5. Ordering Information

5.1 It is the responsibility of the purchaser to specify all requirements that are necessary for the safe and satisfactory performance of material ordered under this specification. Examples of such requirements include but are not limited to the following:

5.1.1 Alloy (Table 2),

5.1.2 *Condition (Temper)*—Table 3 and Table 4, Appendix X1, and Specification B906.

5.1.3 *Finish*—Appendix X1 and Specification B906.

5.1.4 *Dimensions*—Thickness, width, and length.

5.1.5 *Optional Requirements:*

5.1.5.1 *Sheet and Strip*—Whether to be furnished in coil, in cut straight lengths, or in random straight lengths.

5.1.5.2 *Strip*—Whether to be furnished with commercial slit edge, square edge, or round edge.

5.1.5.3 *Plate*—Whether to be furnished specially flattened (see 9.7.2); also how plate is to be cut (Specification B906, Table A3.4 and Table A3.7).

5.1.6 *Fabrication Details*—Not mandatory but helpful to the manufacturer:

5.1.6.1 *Welding or Brazing*—Process to be employed.

5.1.6.2 *Plate*—Whether material is to be hot-formed.

5.1.7 DELETED

TABLE 1 Product Description

Product	Thickness, in. (mm)	Width, in. (mm)
Hot-rolled plate <sup>A</sup>	3/16 and over (B906, Table A3.1 and Table A3.2)	(B906, Table A3.4) <sup>B</sup>
Hot-rolled sheet <sup>A</sup>	0.018 to 0.250 (0.46 to 6.4), incl (B906, Table A3.3)	(B906, Table A3.6)
Cold-rolled sheet <sup>C</sup>	0.018 to 0.250 (0.46 to 6.4), incl (B906, Table A3.3)	(B906, Table A3.6)
Cold-rolled strip <sup>C</sup>	0.005 to 0.250 (0.13 to 6.4), incl (B906, Table A3.3)	(B906, Table A3.6)

<sup>A</sup> Material 3/16 to 1/4 in. (4.8 to 6.4 mm), incl, in thickness may be furnished as sheet or plate provided the material meets the specification requirements for the condition ordered.

<sup>B</sup> Hot-rolled plate, in widths 10 in. (254 mm) and under, may be furnished as hot-finished rectangles with sheared or cut edges in accordance with Specification B409, provided the mechanical property requirements of this specification are met.

<sup>C</sup> Material under 48 in. (1219 mm) in width may be furnished as sheet or strip provided the material meets the specification requirements for the condition ordered.

TABLE 2 Chemical Requirements

Element	Composition Limits, %		
	Alloy N08120	Alloy N08890	Alloys N08800, N08810, and N08811
Nickel	35.0 min 39.0 max	40.0 min 45.0 max	30.0 min 35.0 max
Chromium	23.0 min 27.0 max	23.5 min 28.5 max	19.0 min 23.0 max
Iron	remainder <sup>A</sup>	remainder	39.5 min <sup>A</sup>
Manganese, max	1.5	1.5	1.5 <sup>B</sup>
Carbon	0.02 min 0.10 max	0.06 min 0.14 max	...
Copper, max	0.50	0.75	0.75
Silicon, max	1.0	1.0 min 2.0 max	1.0
Sulfur, max	0.03	0.015	0.015
Aluminum <sup>C</sup>	0.40 max	0.05 min 0.60 max	0.15 min 0.60 max
Titanium <sup>C</sup>	0.20 max	0.15 min 0.60 max	0.15 min 0.60 max
Columbium	0.4 min 0.9 max	...	...
Molybdenum	2.50 max	1.0 min 2.0 max	...
Niobium	...	0.2 min 1.0 max	...
Tantalum	...	0.10 min 0.60 max	...
Phosphorus	0.040 max	...	...
Tungsten	2.50 max	...	...
Cobalt, max	3.0	...	...
Nitrogen	0.15 min 0.30 max	...	...
Boron	0.010 max	...	...

<sup>A</sup> Iron shall be determined arithmetically by difference.

<sup>B</sup> Alloy UNS N08800: 0.10 max.

Alloy UNS N08810: 0.05–0.10.

Alloy UNS N08811: 0.06–0.10.

<sup>C</sup> Alloy UNS N08811: Al + Ti, 0.85–1.20.

5.1.8 *Samples for Product (Check) Analysis*—Whether samples for product (check) analysis should be furnished (see 7.2).

5.1.9 *Purchaser Inspection*—If purchaser wishes to witness tests or inspection of material at place of manufacture, the purchase order must so state indicating which tests or inspections are to be witnessed (Specification B906).

## 6. Materials and Manufacture

6.1 *Heat Treatment*—The final heat treatment of UNS N08120 shall be 2150°F (1177°C) minimum, UNS N08810, 2050°F (1121°C) minimum, UNS N08811 and UNS N08890, 2100°F (1149°C) minimum.

## 7. Chemical Composition

7.1 The material shall conform to the composition limits specified in Table 2.

7.2 If a product (check) analysis is performed by the purchaser, the material shall conform to the product (check) analysis variations in Specification B906.

## 8. Mechanical and Other Requirements

8.1 *Mechanical Properties*—The material shall conform to the mechanical properties specified in Table 3.

8.2 *Grain Size*—Annealed Alloys UNS N08120, UNS N08810, UNS N08811, and UNS N08890 shall conform to an average grain size of ASTM No. 5 or coarser.

8.3 *Deep-Drawing and Spinning Quality Sheet and Strip*—(Alloy UNS N08800) Shall conform to the grain size and hardness requirements as provided in Table 4.

8.3.1 The mechanical properties of Table 3 do not apply to deep drawing and spinning quality sheet and strip.

8.4 *Annealing Temperature*—Alloy UNS N08120 shall be annealed at 2150°F (1177°C) minimum, and UNS N08810, 2050°F (1121°C) minimum.

## 9. Dimensions and Permissible Variations

### 9.1 Thickness and Weight:

9.1.1 *Plate*—For plate up to 2 in. (50.8 mm), incl, in thickness, the permissible variation under the specified thickness and permissible excess in overweight shall not exceed the amounts prescribed in Table A3.1 in Specification B906.

9.1.1.1 For use with Table A3.1 in Specification B906, plate shall be assumed to weigh 0.287 lb/in.<sup>3</sup> (7.944 g/cm<sup>3</sup>).

9.1.2 *Plate*—For plate over 2 in. (50.8 mm) in thickness, the permissible variations over the specified thickness shall not exceed the amounts prescribed in Table A3.2 in Specification B906.

9.1.3 *Sheet and Strip*—The permissible variations in thickness of sheet and strip shall be as prescribed in Table A3.3 in Specification B906. The thickness of sheet and strip shall be measured with the micrometer spindle 3/8 in. (9.5 mm) or more from either edge for material 1 in. (25.4 mm) or over in width and at any place on strip under 1 in. in width.

### 9.2 Width or Diameter:

9.2.1 *Plate*—The permissible variations in width of rectangular plates and diameter of circular plates shall be as prescribed in Table A3.4 and Table A3.5 in Specification B906.

**TABLE 3 Mechanical Properties for Plate, Sheet, and Strip**  
(All thicknesses and sizes unless otherwise indicated)

Alloy	Condition	Tensile Strength, min, psi (MPa)	Yield Strength <sup>A</sup> (0.2 % offset), min, psi (MPa)	Elongation in 2 in. or 50 mm (or 4D), min, %
Hot-Rolled Plate				
UNS N08120	Annealed	90 000 (621)	40 000 (276)	30
UNS N08800	Annealed	75 000 (520)	30 000 (205)	30
UNS N08800	As-rolled <sup>BC</sup>	80 000 (550)	35 000 (240)	25
UNS N08810	Annealed	65 000 (450)	25 000 (170)	30
UNS N08811	Annealed	65 000 (450)	25 000 (170)	30
UNS N08890	Annealed	75 000 (520)	30 000 (205)	35
Hot-Rolled Sheet				
UNS N08120	Annealed	90 000 (621)	40 000 (276)	30
UNS N08800	Annealed	75 000 (520)	30 000 (205)	30
UNS N08810 <sup>D</sup>	Annealed	65 000 (450)	25 000 (170)	30
UNS N08811 <sup>D</sup>	Annealed	65 000 (450)	25 000 (170)	30
UNS N08890	Annealed	75 000 (520)	30 000 (205)	35
Cold-Rolled Sheet				
UNS N08120	Annealed	90 000 (621)	40 000 (276)	30
UNS N08800	Annealed	75 000 (520)	30 000 (205)	30
UNS N08810 <sup>D</sup>	Annealed	65 000 (450)	25 000 (170)	30
UNS N08811 <sup>D</sup>	Annealed	65 000 (450)	25 000 (170)	30
UNS N08890	Annealed	75 000 (520)	30 000 (205)	35
Cold-Rolled Strip				
UNS N08120	Annealed	90 000 (621)	40 000 (276)	30
UNS N08800	Annealed	75 000 (520)	30 000 (205)	30 <sup>E</sup>
UNS N08810 <sup>D</sup>	Annealed	65 000 (450)	25 000 (170)	30
UNS N08811 <sup>D</sup>	Annealed	65 000 (450)	25 000 (170)	30
UNS N08890	Annealed	75 000 (520)	30 000 (205)	35

<sup>A</sup> Yield strength requirements do not apply to material under 0.020 in. (0.51 mm) in thickness.

<sup>B</sup> As-rolled plate may be given a stress-relieving heat treatment subsequent to final rolling.

<sup>C</sup> As-rolled plate specified "suitable for hot forming" shall be furnished from heats of known good hot-malleability characteristics (see X1.1.1.2). The purchaser must specify Alloy UNS N08800 or UNS N08810. There are no applicable tensile or hardness requirements for such material.

<sup>D</sup> Available only in thicknesses 0.115 in. (2.92 mm) and over.

<sup>E</sup> Not applicable for thickness under 0.010 in. (0.25 mm).

**TABLE 4 Grain Size and Hardness for Alloy UNS N08800 Cold-Rolled, Deep-Drawing, and Spinning Quality Sheet and Strip**

Thickness	Calculated Diameter of Average Grain Section, max, in. (mm)	Corresponding ASTM Micro- Grain Size No.	Rockwell B <sup>A,B</sup> Hardness, max
Sheet (56 in. (1.42 m) Wide and Under)			
0.050 (1.3) and less	0.0030 (0.075)	4.5	86
Over 0.050 to 0.250 (1.3 to 6.4), incl	0.0043 (0.110)	3.5	86
Strip (12 in. (305 mm) Wide and Under) <sup>C</sup>			
0.005 <sup>D</sup> to 0.010 (0.13 to 0.25), incl	0.0009 (0.022)	8 <sup>E</sup>	88 <sup>E</sup>
Over 0.010 to 0.125 (0.25 to 3.2), incl	0.0030 (0.075)	4.5	86

<sup>A</sup> For Rockwell or equivalent hardness conversions see Hardness Conversion Tables E140.

<sup>B</sup> Caution should be observed in using the Rockwell test on thin material, as the results may be affected by specimen thickness. For thicknesses under 0.050 in. (1.3 mm), the use of the Rockwell superficial or the Vickers hardness test is suggested.

<sup>C</sup> Sheet requirements (above) apply to strip thicknesses over 0.125 in. (3.2 mm), and for all thicknesses of strip over 12 in. (305 mm) in width.

<sup>D</sup> For ductility evaluations for strip under 0.005 in. (0.13 mm) in thickness, the spring-back test such as described in Test Method F155, is often used and the manufacturer should be consulted.

<sup>E</sup> Accurate grain size and hardness determinations are difficult to make on strip under 0.005 in. (0.13 mm) in thickness and are not recommended.

9.2.2 *Sheet and Strip*—The permissible variations in width for sheet and strip shall be as prescribed in Table A3.6 in Specification B906.

### 9.3 Length:

9.3.1 Sheet and strip of all sizes may be ordered to cut lengths, in which case a variation of 1/8 in. (3.18 mm) over the specified length shall be permitted.

9.3.2 Permissible variations in length of rectangular plate shall be as prescribed in Table A3.7 in Specification B906.

### 9.4 Straightness:

9.4.1 The edgewise curvature (depth of chord) of flat sheet, strip, and plate shall not exceed 0.05 in. multiplied by the length in feet (0.04 mm multiplied by the length in centimetres).

9.4.2 Straightness for coiled strip material is subject to agreement between the manufacturer and the purchaser.

### 9.5 Edges:

9.5.1 When finished edges of strip are specified in the contract or order, the following descriptions shall apply:

9.5.1.1 Square-edge strip shall be supplied with finished edges, with sharp, square corners, without bevel or rounding.

**TABLE 5 Permissible Variations From Flatness of Rectangular, Circular, and Sketch Plates**

NOTE 1—Permissible variations apply to plates up to 12 ft (366 cm) in length, or to any 12 ft (366 cm) of longer plates.

NOTE 2—If the longer dimension is under 36 in. (914 mm), the permissible variation is not greater than ¼ in. (6.35 mm).

NOTE 3—The shorter dimension specified is considered the width, and the permissible variation in flatness across the width does not exceed the tabular amount of that dimension.

NOTE 4—The maximum deviation from a flat surface does not customarily exceed the tabular tolerance for the longer dimension specified.

Specified Thickness	Permissible Variations from a Flat Surface for Thickness and Widths Given, in. (mm)								
	To 48 (1220), excl	48 to 60 (1220 to 1520), excl	60 to 72 (1520 to 1830), excl	72 to 84 (1830 to 2130), excl	84 to 96 (2130 to 2440), excl	96 to 108 (2440 to 2740), excl	108 to 120 (2740 to 3050), excl	120 to 144 (3050 to 3660), excl	144 (3660) and Over
	Inches								
3/16 to 1/4, excl	3/4	1 1/16	1 1/4	1 3/8	1 5/8	1 5/8	...	...	...
1/4 to 3/8, excl	1 1/16	3/4	1 5/16	1 1/8	1 3/8	1 7/16	1 9/16	1 7/8	...
3/8 to 1/2, excl	1/2	9/16	1 1/16	3/4	1 5/16	1 1/2	1 1/4	1 7/16	1 3/4
1/2 to 3/4, excl	1/2	9/16	5/8	5/8	1 3/16	1 1/8	1 1/8	1 1/8	1 3/8
3/4 to 1, excl	1/2	9/16	5/8	5/8	3/4	1 3/16	1 5/16	1	1 1/8
1 to 2, excl	1/2	9/16	5/8	9/16	1 1/16	1 1/16	1 1/16	3/4	1
2 to 4, incl	1/4	5/16	3/8	7/16	1/2	9/16	5/8	3/4	7/8
	Millimetres								
4.76 to 6.35, excl	19.05	27.0	31.7	34.9	41.3	41.3	...	...	...
6.35 to 9.52, excl	17.46	19.05	23.81	28.6	35.0	36.5	39.7	47.6	...
9.52 to 12.70, excl	12.70	14.29	17.46	19.05	23.8	28.6	31.7	35.0	44.4
12.70 to 19.05, excl	12.70	14.29	15.88	15.88	20.64	28.6	28.6	28.6	34.9
19.05 to 25.4, excl	12.70	14.29	15.88	15.88	19.05	20.64	23.81	25.4	28.6
25.4 to 50.8, excl	12.70	14.29	14.29	14.29	17.46	17.46	17.46	19.05	25.4
50.8 to 101.6, incl	6.35	7.94	9.52	11.11	12.70	14.29	15.88	19.05	22.22

9.5.1.2 Round-edge strip shall be supplied with finished edges, semicircular in form, the diameter of the circle forming the edge being equal to the strip thickness.

9.5.1.3 When no description of any required form of strip edge is given, it shall be understood that edges such as those resulting from slitting or shearing will be acceptable.

9.5.1.4 Sheet shall have sheared or slit edges.

9.5.1.5 Plate shall have sheared or cut (machined, abrasive-cut, powder-cut, or inert arc-cut) edges, as specified.

**9.6 Squareness (Sheet):**

9.6.1 For sheets of all thicknesses, the angle between adjacent sides shall be 90 ± 0.15° (1/16 in. in 24 in.) (1.59 mm in 610 mm).

**9.7 Flatness:**

9.7.1 There shall be no flatness requirements for “deep-drawing quality” and “spinning quality” sheet and strip (see X1.1.3).

9.7.2 Standard flatness tolerances for plate shall conform to the requirements of Table 5. “Specially-flattened” plate when so specified, shall have permissible variations in flatness as agreed upon between the manufacturer and the purchaser.

**10. Test Methods**

10.1 The chemical composition, mechanical, and other properties of the material as enumerated in this specification shall be determined, in case of disagreement, in accordance with the methods in Specification B906.

10.2 The measurement of average grain size may be carried out by the planimetric method, the comparison method, or the

intercept method described in Specification B906. In case of dispute, the “referee” method for determining average grain size shall be the planimetric method.

10.3 For purposes of determining compliance with the specified limits for requirements of the properties listed in Specification B409, an observed value or a calculated value shall be rounded as indicated below, in accordance with the rounding methods in Specification B906.

Test	Rounded Unit for Observed or Calculated Value
Elongation	nearest 1 %
Grain size:	
0.0024 in. (0.060 mm) or larger	nearest multiple of 0.0002 in. (0.005 mm)
less than 0.0024 in. (0.060 mm)	nearest multiple of 0.0001 in. (0.002 mm)

**11. Certification and Test Report**

11.1 A certification and test report shall be supplied per Specification B906, paragraph 21.

**12. Product Marking**

12.1 Each bundle or shipping container shall be marked with the name of the material; condition (temper); this specification number; the size; gross, tare, and net weight; consignor and consignee address; contract or order number; or such other information as may be defined in the contract or order.

**13. Keywords**

13.1 plate; sheet; strip; UNS N08120; UNS N08800; UNS N08801; UNS N08810; UNS N08811; UNS N08890

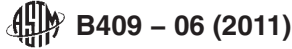

## APPENDIX

(Nonmandatory Information)

## X1. CONDITIONS (TEMPERS) AND FINISHES

X1.1 This appendix lists the conditions and finishes in which plate, sheet, and strip are normally supplied. These are subject to change and the manufacturer should be consulted for the latest information available.

X1.1.1 *Plate, Hot Rolled:*

X1.1.1.1 *Annealed*—Soft with an oxide surface, and suitable for heavy cold forming. Available with a descaled surface, when so specified.

X1.1.1.2 *As-Rolled*—With an oxide surface. Available with a descaled surface, when so specified. Suitable for flat work, mild forming, or tube sheets. When intended for tube sheets, specify that plates are to be specially flattened. When intended for hot forming, this should be indicated on the purchase order so that the manufacturer may select appropriate material.

X1.1.2 *Plate, Cold Rolled:*

X1.1.2.1 *Annealed*—Soft with an oxide surface; available with a descaled surface when so specified.

X1.1.3 *Sheet, Hot-Rolled, Annealed, and Pickled*—Soft with a pickled matte finish. Properties similar to X1.1.4.1 but with broader thickness tolerances. Not suggested for applications where the finish of a cold-rolled sheet is considered essential, or for deep drawing, or spinning.

X1.1.4 *Sheet and Strip, Cold-Rolled:*

X1.1.4.1 *Annealed*—Soft with a descaled or bright annealed finish.

X1.1.4.2 *Deep-Drawing or Spinning Quality*—Similar to X1.1.4.1, except furnished to controlled hardness and grain size and lightly leveled.

# SPECIFICATION FOR NICKEL-IRON-CHROMIUM- MOLYBDENUM-COPPER ALLOY (UNS N08825 AND N08221) SEAMLESS PIPE AND TUBE



**SB-423**

(Identical with ASTM Specification B423-05(2009) except that certification is mandatory, 4.1.8 has been changed to reference 9.1, and an editorial correction to X1.1.)

# SPECIFICATION FOR NICKEL-IRON-CHROMIUM-MOLYBDENUM-COPPER ALLOY (UNS N08825 AND N08221) SEAMLESS PIPE AND TUBE



SB-423

[Identical with ASTM Specification B 423-05(2009) except that certification is mandatory, 4.1.8 has been changed to reference 9.1, and an editorial correction to X1.1.]

## 1. Scope

**1.1** This specification covers nickel-iron-chromium-molybdenum-copper alloys (UNS N08825 and N08221) in the form of cold-worked and hot-finished seamless pipe and tube intended for general corrosive service. The general requirements for pipe and tube are covered in Specification B 829.

**1.2** The following precautionary caveat pertains only to the test methods portion, Section 9, of this specification: *This standard does not purport to address all of the safety concerns, if any, associated with its use. It is the responsibility of the user of this standard to become familiar with all hazards including those identified in the appropriate Material Safety Data Sheet (MSDS) for this product/material as provided by the manufacturer, to establish appropriate safety and health practices, and determine the applicability of regulatory limitations prior to use.*

## 2. Referenced Documents

### 2.1 ASTM Standards:

B 829 Specification for General Requirements for Nickel and Nickel Alloys Seamless Pipe and Tube

## 3. General Requirement

**3.1** Material furnished under this specification shall conform to the applicable requirements of Specification B 829 unless otherwise provided herein.

## 4. Ordering Information

**4.1** It is the responsibility of the purchaser to specify all requirements that are necessary for the safe and satisfactory performance of material ordered under this specification.

Examples of such requirements include, but are not limited to, the following:

**4.1.1** Alloy name or UNS number,

**4.1.2** ASTM designation,

**4.1.3** Condition (see Appendix X2),

**4.1.4** Finish (see Appendix X2),

**4.1.5** *Dimensions:*

**4.1.5.1** *Tube*—Specify outside diameter and nominal or minimum wall,

**4.1.5.2** *Pipe*—Specify standard pipe size and schedule,

**4.1.5.3** *Length*—Cut to length or random,

**4.1.6** *Quantity*—Feet (or metres) or number of pieces,

**4.1.7** *Hydrostatic Test or Nondestructive Electric Test*—Specify type of test (see 6.2).

**4.1.8** *Hydrostatic Pressure Requirements*—Specify test pressure if other than required by 9.1.

**4.1.9** *Certification*—Certification is required,

**4.1.10** *Samples for Product (Check) Analysis*—State whether samples for product (check) analysis should be furnished (see 5.2),

**4.1.11** *Purchaser Inspection*—If purchaser wishes to witness tests or inspection of material at place of manufacture, the purchase order must so state indicating which tests or inspections are to be witnessed, and

**4.1.12** *Small-Diameter and Light-Wall Tube (Converter Sizes)*—See Appendix X1.

## 5. Chemical Composition

**5.1** The material shall conform to the composition limits specified in Table 1. One test is required for each lot as defined in Specification B 829.

TABLE 1  
CHEMICAL REQUIREMENTS

Element	UNS N08825	UNS N08221
Nickel	38.0–46.0	39.0–46.0
Chromium	19.5–23.5	20.0–22.0
Iron	22.0 min	22.0 min
Manganese	1.0 max	1.0 max
Carbon	0.05 max	0.025 max
Copper	1.5–3.0	1.5–3.0
Silicon	0.5 max	0.5 max
Sulfur	0.03 max	0.03 max
Aluminum	0.2 max	0.2 max
Titanium	0.6–1.2	0.6–1.0
Molybdenum	2.5–3.5	5.0–6.5

5.2 If a product (check) analysis is performed by the purchaser, the material shall conform to the product (check) analysis variations of Specification B 829.

## 6. Mechanical Properties and Other Requirements

6.1 *Tension Test*—The material shall conform to the tensile properties specified in Table 2. The sampling and specimen preparation are as covered in Specification B 829.

6.1.1 Tensile properties for material specified as small-diameter and light-wall tube (converter sizes) shall be as prescribed in Table X1.1.

6.2 *Hydrostatic or Nondestructive Electric Test*—Each pipe or tube shall be subjected to either the hydrostatic test or the nondestructive electric test. The type of test to be used shall be at the option of the manufacturer, unless otherwise specified in the purchase order.

## 7. Dimensions and Permissible Variations

7.1 *Diameter and Wall Thickness*—The permissible variations in the outside diameter and wall thickness shall conform to the permissible variations prescribed in Tables 3, 4, and 5 of Specification B 829.

7.2 Permissible variations for material specified as small-diameter and light-wall tube (converter size) shall conform to the permissible variations prescribed in Table X1.2.

## 8. Number of Tests

8.1 *Chemical Analysis*—One test per lot.

8.2 *Tension*—One test per lot.

8.3 *Hydrostatic or Nondestructive Electric Test*—Each piece in each lot.

## 9. Test Methods

9.1 *Hydrostatic Test*—Each pipe or tube with an outside diameter  $\frac{1}{8}$  in. (3 mm) and larger and with wall thickness of 0.015 in. (0.38 mm) and over shall be tested in accordance with Specification B 829. The allowable fiber stress, for material in the condition furnished, is as follows:

UNS N08825 hot finished, annealed:	16 600 psi (114 MPa)
UNS N08825 cold-worked, annealed:	21 200 psi (146 MPa)
UNS N08221 cold finished, annealed:	19 700 psi (138 MPa)

9.1.1 When so agreed upon between the manufacturer and purchaser, pipe or tube may be tested to  $1\frac{1}{2}$  times the allowable fiber stress given in 9.1.

9.1.2 If any pipe or tube shows leaks during hydrostatic testing, it shall be rejected.

9.2 *Nondestructive Electric Test*—Each pipe or tube shall be examined with a nondestructive electric test in accordance with Specification B 829.

## 10. Keywords

10.1 N08221; N08825; seamless pipe; seamless tube

TABLE 2  
MECHANICAL PROPERTIES OF PIPE AND TUBE

Alloy	Condition and Size	Tensile Strength, min, ksi (MPa)	Yield Strength 0.2% Offset, min, ksi (MPa)	Elongation in 2 in. or 50 mm (4D), min, %
UNS N08825	hot-finished annealed	75 (517)	25 (172)	30
UNS N08825	cold-worked annealed	85 (586)	35 (241)	30
UNS N08825	hot-forming quality (hot-finished or cold-drawn annealed)	(A)	(A)	(A)
UNS N08221	cold-finished, annealed	79 (545)	34 (234)	30

NOTE:

(A) Hot-forming quality is furnished to chemical requirements and surface inspection only. No mechanical properties are required.

## APPENDIXES

## (Nonmandatory Information)

**X1. CONVERTER SIZES**

**X1.1** Small-diameter and light-wall tube in outside diameters  $1\frac{1}{4}$  in. (31.8 mm) and under may be furnished in the conditions listed in Table X1.1 when so specified. The material is furnished in a limited range of sizes and the manufacturer should be consulted as to the various outside diameters and wall thicknesses that may be furnished. Material will have a bright finish. Such material shall conform to the applicable requirements in Table X1.1 and Table X1.2.

**X2. CONDITIONS AND FINISHES NORMALLY SUPPLIED****X2.1 Scope**

**X2.1.1** This appendix lists the conditions and finishes in which pipe and tube (other than converter sizes) are normally supplied. These are subject to change, and the manufacturer should be consulted for the latest information available.

**X2.2 Cold-Worked Tube and Pipe**

**X2.2.1 Cold-Worked, Annealed, with Ground Outside Diameter**—The inside diameter may have a bright finish when material is annealed in a protective atmosphere; otherwise, the inside diameter is supplied descaled as necessary. It is available in sizes  $\frac{1}{2}$  to 4 in. (12.7 to 102 mm),

inclusive, in outside diameter in both normal and heavy-wall tube, and pipe sizes, all schedules, of corresponding outside-diameter dimensions.

**X2.2.2 Cold-Worked, Annealed, and Pickled (Not Ground)**—Outside and inside diameter will have dull, matte (pickled) surfaces. It is available in sizes  $\frac{1}{2}$  to  $6\frac{3}{8}$  in. (12.7 to 168 mm), inclusive, in outside diameter in both normal and heavy-wall tube, and pipe sizes, all schedules, of corresponding outside-diameter dimensions.

**X2.3 Hot-Worked Tube**

**X2.3.1 Hot-Worked-Annealed (Not Pickled) Tube**—Has an oxide surface resulting from the hot-working operation. Intended generally for machined parts where the oxide surface will be removed.

**X2.3.2 Hot-Worked-Annealed (Pickled) Tube**—Has the oxide surface removed on both outside and inside diameters by pickling. Surface may be spot ground for removal of minor surface imperfections at the manufacturer's option.

**X2.3.3 Hot-Worked-Annealed (Machined Outside and Inside Diameters) Tubes**—The outside and inside diameter surfaces are machined to specified dimensions. Minor surface imperfections may be spot ground for removal, at the manufacturer's option.

TABLE X1.1  
MECHANICAL PROPERTIES (A) OF SMALL-DIAMETER AND LIGHT-WALL TUBING (CONVERTER SIZES)

Condition	Tensile Strength, ksi (MPa)	Yield Strength (0.2% offset) min, ksi (MPa)	Elongation in 2 in. or 50 mm, min, %
Annealed (B, C)	85–115 (586–793)	35 (241)	30
Half-hard (D)	105 (724) min	75 (517)	15
Full-hard (E)	125 (862) min	100 (689)	5

## NOTES:

- (A) Not applicable to outside diameters under  $\frac{1}{8}$  in. (3.2 mm) and wall thickness under 0.015 in. (0.381 mm).  
 (B) This condition is sometimes designated as "No. 1 Temper."  
 (C) The minimum tensile strength value applies only to tubing in straight lengths.  
 (D) This condition is sometimes designated as "No. 2 Temper."  
 (E) This condition is sometimes designated as "No. 3 Temper."

TABLE X1.2  
PERMISSIBLE VARIATIONS FOR SMALL-DIAMETER AND LIGHT-WALL TUBE (CONVERTER SIZES)

Specified Outside Diameter, in. (mm)	Outside Diameter, in. (mm)		Inside Diameter, in. (mm)		Wall Thickness, %	
	+	-	+	-	+	-
	Under $\frac{3}{32}$ (2.4)	0.002 (0.05)	0	0	0.002 (0.05)	10
$\frac{3}{32}$ to $\frac{3}{16}$ (2.4 to 4.8), excl	0.003 (0.08)	0	0	0.003 (0.08)	10	10
$\frac{3}{16}$ to $\frac{1}{2}$ (4.8 to 12.7), excl	0.004 (0.10)	0	0	0.004 (0.10)	10	10
$\frac{1}{2}$ to $1\frac{1}{4}$ (12.7 to 31.8), incl	0.005 (0.13)	0	0	0.005 (0.13)	10	10

## NOTES:

- (A) *Ovality, Normal Wall Tube—As-Drawn (No. 2 and 3) Tempers*—Ovality will be held within the outside diameter tolerances shown in the table.  
*Annealed (No. 1) Temper*—Ovality will be held within 2% of the theoretical average outside diameter.
- (B) *Ovality, Light Wall Tube—As-Drawn (No. 2 and 3) Tempers*—Up to but not including  $1\frac{1}{4}$  in. (31.8 mm) in outside diameter, ovality will be held within 2% of the theoretical average outside diameter.  
*Annealed (No. 1) Temper*—Ovality will be held within 3% of the theoretical average outside diameter.
- (C) *Wall Tolerances, Light Wall Tube*—The plus and minus wall tolerance shown in the table shall apply down to and including 0.005 in. (0.13 mm) in wall thickness. For wall thicknesses less than 0.005 in. (0.13 mm), the tolerance shall be  $\pm 0.0005$  in. (0.013 mm).
- (D) *Random Lengths:*  
Where nominal random lengths on tubing  $\frac{1}{8}$  in. (3.2 mm) and larger in outside diameter are specified, a length tolerance of  $\pm 3\frac{1}{2}$  ft (1.06 m) applies to the nominal length. This is a total spread of 7 ft (2.10 m).  
Random lengths in sizes  $\frac{1}{8}$  in. (3.2 mm) and larger in outside diameter shall be subject to a length range of 5 to 24 ft (1.50 to 7.30 m). Long random lengths are subject to a range of 15 to 22 ft (4.57 to 6.70 m).  
Random lengths in sizes up to, but not including,  $\frac{1}{8}$  in. (3.2 mm) in outside diameter and fragile light-wall tubes over this outside diameter are subject to the length range of 1 to 15 ft (0.30 to 4.57 m).
- (E) *Cut Lengths*—Tolerances on cut lengths shall be in accordance with Table X1.2.
- (F) *Straightness*—Round tubing is subject to a straightness tolerance of one part in 600 [equivalent to a depth of arc of 0.030 in. (0.76 mm) in any 3 ft (0.91 m) on length].
- (G) When specified, the tolerance spreads of this table may be applied as desired. However, when not specified, the tolerances in this table will apply. It should be noted that inside diameter tolerances are based upon the outside diameter range.

TABLE X1.3  
TOLERANCES ON CUT LENGTHS OF LIGHT-WALL TUBE

Length, ft (m)	Tube Size, in. (mm)	Permissible Variations, in. (mm)	
		Over	Under
Under 1 (0.30)	up to 1.250 (31.8), incl	$\frac{1}{32}$ (0.8)	0 (0)
1 to 4 (0.30 to 1.22), incl	up to 1.250 (31.8), incl	$\frac{1}{16}$ (1.6)	0 (0)
Over 4 to 10 (1.22 to 3.0), incl	up to 1.250 (31.8), incl	$\frac{3}{32}$ (2.4)	0 (0)
Over 10 (3.0)	up to 1.250 (31.8), incl	$\frac{3}{16}$ (4.8)	0 (0)

ASMENORMDOC.COM : Click to view the full PDF of ASME BPVC.II.B (ASME BPVC Section II part B) 2025

INTENTIONALLY LEFT BLANK

**SPECIFICATION FOR Ni-Fe-Cr-Mo-Cu ALLOY (UNS  
N08825, UNS N08221, AND UNS N06845) PLATE,  
SHEET, AND STRIP**



**SB-424**

(Identical with ASTM Specification B424-11 except that certification has been made mandatory and a report of test results shall be furnished.)

# Standard Specification for Ni-Fe-Cr-Mo-Cu Alloy (UNS N08825, UNS N08221, and UNS N06845) Plate, Sheet, and Strip

## 1. Scope

1.1 This specification covers rolled nickel-iron-chromium-molybdenum-copper alloy (UNS N08825, UNS N08221, and UNS N06845) plate, sheet, and strip.

1.2 The values stated in inch-pound units are to be regarded as standard. The values given in parentheses are mathematical conversions to SI units that are provided for information only and are not considered standard.

1.3 *This standard does not purport to address all of the safety concerns, if any, associated with its use. It is the responsibility of the user of this standard to become familiar with all hazards including those identified in the appropriate Material Safety Data Sheet (MSDS) for this product/material as provided by the manufacturer, to establish appropriate safety and health practices, and determine the applicability of regulatory limitations prior to use.*

## 2. Referenced Documents

### 2.1 ASTM Standards:

B425 Specification for Ni-Fe-Cr-Mo-Cu Alloy (UNS N08825, UNS N08221, and UNS N06845) Rod and Bar  
B906 Specification for General Requirements for Flat-Rolled Nickel and Nickel Alloys Plate, Sheet, and Strip

## 3. Terminology

3.1 *Descriptions of Terms Specific to This Standard*—Descriptions of Terms Specific to This Standard—The terms given in Table 1 shall apply.

## 4. General Requirements

4.1 Material furnished under this specification shall conform to the applicable requirements of Specification B906.

## 5. Ordering Information

5.1 It is the responsibility of the purchaser to specify all requirements that are necessary for the safe and satisfactory performance of material ordered under this specification. Examples of such requirements include, but are not limited to, the following:

5.1.1 ASTM designation and year of issue.

5.1.2 Alloy name or UNS number.

5.1.3 *Condition*—Table 3 and Appendix X1.

5.1.4 *Finish*—Appendix X1.

5.1.5 *Dimensions*—Thickness, width, and length.

5.1.6 *Quantity*.

5.1.7 *Optional Requirements*:

5.1.7.1 *Sheet and Strip*—Whether to be furnished in coil, in cut straight lengths, or in random straight lengths.

5.1.7.2 *Strip*—Whether to be furnished with commercial slit edge, square edge, or round edge.

5.1.7.3 *Plate*—Whether to be furnished specially flattened (see 8.7); also how plate is to be cut (Table 4).

5.1.8 DELETED

5.1.9 *Samples for Product (Check) Analysis*—Whether samples for product (check) analysis should be furnished (see Specification B906, section on Sampling).

5.1.10 *Purchaser Inspection*—If the purchaser wishes to witness tests or inspection of material at the place of manufacture, the purchase order must so state, indicating which tests or inspections are to be witnessed (Specification B906, section on Inspection).

## 6. Chemical Composition

6.1 The material shall conform to the composition limits specified in Table 2.

6.2 If a product (check) analysis is performed by the purchaser, the material shall conform to the product (check) analysis per Specification B906.

TABLE 1 Product Description

Product	Thickness, in. (mm)
Hot-rolled plate <sup>A</sup>	3/16 (4.76) and over
Cold-rolled plate <sup>A</sup>	3/16 to 3/8 (4.8 to 9.5), incl
Hot-rolled sheet <sup>A</sup>	0.018 to 0.250 (0.46 to 6.4), incl
Cold-rolled sheet <sup>B</sup>	0.018 to 0.250 (0.46 to 6.4), incl
Cold-rolled strip <sup>B</sup>	0.005 to 0.250 (0.13 to 6.4), incl

<sup>A</sup> Material 3/16 to 1/4 in. (4.8 to 6.4 mm), incl, in thickness may be furnished as sheet or plate provided the material meets the specification requirements for the condition ordered.

<sup>B</sup> Material under 48 in. (1219 mm) in width may be furnished as sheet or strip provided the material meets the specification requirements for the condition ordered.

## 7. Mechanical Properties

7.1 *Mechanical Properties*—The material shall conform to the mechanical properties specified in Table 3.

## 8. Dimensions and Permissible Variations

### 8.1 Thickness and Weight:

8.1.1 *Plate*—For plate up to 2 in. (50.8 mm), inclusive, in thickness, the permissible variation under the specified thickness and permissible excess in overweight shall not exceed the amounts prescribed in Specification B906, Permissible Variations in Thickness and Overweight of Rectangular Plates Table.

8.1.1.1 For use with Specification B906, Permissible Variations in Thickness and Overweight of Rectangular Plates Table, plate shall be assumed to weigh 0.294 lb/in.<sup>3</sup> (8.138 g/cm<sup>3</sup>).

8.1.2 *Plate*—For plate over 2 in. (50.8 mm) in thickness, the permissible variations over the specified thickness shall not exceed the amounts prescribed in Specification B906, Permissible Variations in Thickness for Rectangular Plates Over 2 in. (51 mm) in Thickness Table.

8.1.3 *Sheet and Strip*—The permissible variations in thickness of sheet and strip shall be as prescribed in Specification B906, Permissible Variations in Thickness of Sheet and Strip Table. The thickness of strip and sheet shall be measured with the micrometer spindle 3/8 in. (9.5 mm) or more from either edge for material 1 in. (25.4 mm) or over in width and at any place on the strip under 1 in. (25.4 mm) in width.

### 8.2 Width or Diameter:

8.2.1 *Plate*—The permissible variations in width of rectangular plates and diameter of circular plates shall be as prescribed in Specification B906, Permissible Variations in Width of Sheared, Plasma Torch-Cut, and Abrasive-Cut Rectangular Plate Table and Permissible Variations in Diameter for Circular Plates Table.

8.2.2 *Sheet and Strip*—The permissible variations in width for sheet and strip shall be as prescribed in Specification B906, Permissible Variations in Width of Sheet and Strip Table.

### 8.3 Length:

8.3.1 Sheet and strip of all sizes may be ordered to cut

lengths, in which case a variation of 1/8 in. (3.2 mm) over the specified length shall be permitted.

8.3.2 Permissible variations in length of rectangular plate shall be as prescribed in Specification B906, Permissible Variations in Length of Sheared, Plasma, Torch-Cut, and Abrasive-Cut Rectangular Plate Table.

### 8.4 Straightness:

8.4.1 The edgewise curvature (depth of chord) of flat sheet, strip, and plate shall not exceed 0.05 in. (1.27 mm) multiplied by the length in feet (0.04 mm multiplied by the length in centimetres).

8.4.2 Straightness for coiled material is subject to agreement between the manufacturer and the purchaser.

### 8.5 Edges:

8.5.1 When finished edges of strip are specified in the contract or order, the following descriptions shall apply:

8.5.1.1 Square-edge strip shall be supplied with finished edges, with sharp, square corners, without bevel or rounding.

8.5.1.2 Round-edge strip shall be supplied with finished edges, semicircular in form, the diameter of the circle forming the edge being equal to the strip thickness.

8.5.1.3 When no description of any required form of strip edge is given, it shall be understood that edges such as those resulting from slitting or shearing will be acceptable.

8.5.1.4 Sheet shall have sheared or slit edges.

8.5.1.5 Plate shall have sheared or cut (machined, abrasive cut, powder cut, or inert arc cut) edges, as specified.

8.6 *Squareness (Sheet)*—For sheets of all thicknesses, the angle between adjacent sides shall be  $90 \pm 0.15^\circ$  (1/16 in. in 24 in.) (1.6 mm in 610 mm).

8.7 *Flatness*—Standard flatness tolerances for plate shall conform to the requirements of Table 4. “Specifically-flattened” plate, when so specified, shall have permissible variations in flatness as agreed upon between the manufacturer and the purchaser.

## 9. Product Marking

9.1 Each bundle or shipping container shall be marked with the name of the material or UNS number; condition; this specification number; the size; gross, tare, and net weight; consignor and consignee address; contract or order number; or such other information as may be defined in the contract or order.

## 10. Certification

10.1 A certification shall be furnished to the purchaser that the material was manufactured, sampled, tested, and inspected in accordance with this specification and has been found to meet the requirements. A report of the results shall be furnished.

## 11. Keywords

11.1 N08825; N08221; N06845; plate; sheet; strip

**TABLE 2 Chemical Requirements<sup>A</sup>**

Element	UNS N08825	UNS N08221	UNS N06845
Nickel	38.0 to 46.0	39.0 to 46.0	44.0 to 50.0
Chromium	19.5 to 23.5	20.0 to 22.0	20.0 to 25.0
Iron	22.0 min <sup>B</sup>	Balance <sup>B</sup>	Remainder <sup>B</sup>
Manganese	1.0	1.0	0.5
Carbon	0.05	0.025	0.05
Copper	1.5 to 3.0	1.5 to 3.0	2.0 to 4.0
Silicon	0.5	0.5	0.5
Sulfur	0.03	0.03	0.010
Aluminum	0.2	0.2	...
Titanium	0.6 to 1.2	0.6 to 1.0	...
Molybdenum	2.5 to 3.5	5.0 to 6.5	5.0 to 7.0
Tungsten	...	...	2.0 to 5.0

<sup>A</sup> Maximum unless range or minimum is given. Where ellipses (...) appear in this table, there is no requirement and analysis for the element need not be determined or reported.

<sup>B</sup> Element shall be determined arithmetically by difference.

**TABLE 3 Mechanical Properties for Plate, Sheet, and Strip**  
(All Thicknesses and Sizes Unless Otherwise Indicated)

Alloy	Condition	Tensile Strength, min, ksi (MPa)	Yield Strength <sup>A</sup> (0.2 % Offset), min, ksi (MPa)	Elongation in 2 in. or 50 mm (or 4 D), min, %
<i>Hot-Rolled Plate:</i>				
UNS N08825	annealed	85 (586)	35 (241)	30
UNS N08221	annealed	79 (544)	34 (235)	30
UNS N06845	annealed	100 (690)	40 (276)	30
<i>Cold-Rolled Plate:</i>				
UNS N08825	annealed	85 (586)	35 (241)	30
UNS N08221	annealed	79 (544)	34 (235)	30
UNS N06845	annealed	100 (690)	40 (276)	30
<i>Hot-Rolled Sheet:</i>				
UNS N08825	annealed	85 (586)	35 (241)	30
UNS N08221	annealed	79 (544)	34 (235)	30
UNS N06845	annealed	100 (690)	40 (276)	30
<i>Cold-Rolled Sheet:</i>				
UNS N08825	annealed	85 (586)	35 (241)	30
UNS N08221	annealed	79 (544)	34 (235)	30
UNS N06845	annealed	100 (690)	40 (276)	30
<i>Cold-Rolled Strip:</i>				
UNS N08825	annealed	85 (586) <sup>B</sup>	35 (241)	30 <sup>B</sup>
UNS N08221	annealed	79 (544) <sup>B</sup>	34 (235)	30 <sup>B</sup>
UNS N06845	annealed	100 (690) <sup>B</sup>	40 (276)	30

<sup>A</sup> Yield strength requirements do not apply to material under 0.020 in. (0.51 mm) in thickness.

<sup>B</sup> Not applicable for thickness under 0.010 in. (0.25 mm).

**TABLE 4 Permissible Variations From Flatness of Rectangular, Circular, and Sketch Plates**

NOTE 1—Permissible variations apply to plates up to 12 ft (3.66 m) in length, or to any 12 ft (3.66 m) of longer plates. If the longer dimension is under 36 in. (914 mm), the permissible variation is not greater than 1/4 in. (6.4 mm).

NOTE 2—The shorter dimension specified is considered the width, and the permissible variation in flatness across the width does not exceed the tabular amount of that dimension.<sup>A</sup>

NOTE 3—The maximum deviation from a flat surface does not customarily exceed the tabular tolerance for the longer dimension specified.

Specified Thickness	Permissible Variations from a Flat Surface for Thickness and Widths Given, in. (mm)								
	To 48 (1220), excl	48 to 60 (1220 to 1520), excl	60 to 72 (1520 to 1830), excl	72 to 84 (1830 to 2130), excl	84 to 96 (2130 to 2440), excl	96 to 108 (2440 to 2740), excl	108 to 120 (2740 to 3050), excl	120 to 144 (3050 to 3660), excl	144 (3660), and over
	Inches								
3/16 to 1/4, excl	3/4	1 1/16	1 1/4	1 3/8	1 5/8	1 5/8	...	...	...
1/4 to 3/8, excl	1 1/16	3/4	1 1/16	1 1/8	1 3/8	1 7/16	1 9/16	1 7/8	...
3/8 to 1/2, excl	1/2	9/16	1 1/16	3/4	1 1/16	1 1/8	1 1/4	1 1/16	1 3/4
1/2 to 3/4, excl	1/2	9/16	5/8	5/8	1 1/16	1 1/8	1 1/8	1 1/8	1 3/8
3/4 to 1, excl	1/2	9/16	5/8	5/8	3/4	1 1/16	1 1/16	1	1 1/8
1 to 2, excl	1/2	9/16	9/16	9/16	1 1/16	1 1/16	1 1/16	3/4	1
2 to 4, incl	1/4	5/16	3/8	7/16	1/2	9/16	5/8	3/4	7/8
	Millimetres								
4.8 to 6.4, excl	19.05	27.0	31.7	34.9	41.3	41.3	...	...	...
6.4 to 9.5, excl	17.5	19.0	23.8	28.6	35.0	36.5	39.7	47.6	...
9.5 to 12.7, excl	12.7	14.3	17.5	19.0	23.8	28.6	31.7	35.0	44.4
12.7 to 19.0, excl	12.7	14.3	15.9	15.9	20.6	28.6	28.6	28.6	34.9
19.0 to 25.4, excl	12.7	14.3	15.9	15.9	19.0	20.6	23.8	25.4	28.6
25.4 to 50.8, excl	12.7	14.3	14.3	14.2	17.5	17.5	17.5	19.0	25.4
50.8 to 101.6, incl	6.4	7.9	9.5	11.1	12.7	14.3	15.9	19.0	22.2

<sup>A</sup> Editorially corrected.

**APPENDIX**

**(Nonmandatory Information)**

**X1. CONDITIONS AND FINISHES NORMALLY SUPPLIED**

**X1.1 Scope**

X1.1.1 This appendix lists the conditions and finishes in which plate, sheet, and strip are normally supplied. These are subject to change, and the manufacturer should be consulted for the latest information available.

**X1.2 Plate**

- X1.2.1 Hot-rolled, annealed, and descaled.
- X1.2.2 Cold-rolled, annealed, and descaled.

**X1.3 Sheet**

- X1.3.1 Hot-rolled, annealed, and descaled.
- X1.3.2 Cold-rolled, annealed, and descaled or bright annealed.

**X1.4 Strip**

- X1.4.1 Cold-rolled, annealed, descaled, or bright annealed.

ASMENORMDOC.COM : Click to view the full PDF of ASME BPVC.II.B (ASME BPVC Section II part B) 2025

INTENTIONALLY LEFT BLANK

# SPECIFICATION FOR Ni-Fe-Cr-Mo-Cu ALLOY (UNS N08825 AND UNS N08221) ROD AND BAR



SB-425

(Identical with ASTM Specification B425-99 (2009) except that certification has been made mandatory.)

ASMENORMDOC.COM : Click to view the full PDF of ASME BPVC.II.B (ASME BPVC Section II part B) 2025

# SPECIFICATION FOR Ni-Fe-Cr-Mo-Cu ALLOY (UNS N08825 AND UNS N08221) ROD AND BAR



SB-425

[Identical with ASTM Specification B 425-99(2009) except that certification has been made mandatory.]

## 1. Scope

**1.1** This specification covers nickel-iron-chromium-molybdenum-copper alloy (UNS N08825 and UNS N08221) in the form of hot-finished and cold-drawn rounds, squares, hexagons, and rectangles.

**1.2** The values stated in inch-pound units are to be regarded as the standard. The values given in parentheses are for information only.

**1.3** The following precautionary caveat pertains only to the test methods portion, Section 12, of this specification: *This standard does not purport to address all of the safety problems, if any, associated with its use. It is the responsibility of the user of this standard to establish appropriate safety and health practices and determine the applicability of regulatory limitations prior to use.*

## 2. Referenced Documents

### 2.1 ASTM Standards:

- B 424 Specification for Ni-Fe-Cr-Mo-Cu Alloy (UNS N08825 and UNS N08221) Plate, Sheet, and Strip
- B 880 Specification for General Requirements for Chemical Check Analysis Limits for Nickel, Nickel Alloys and Cobalt Alloys
- E 8 Test Methods for Tension Testing of Metallic Materials
- E 29 Practice for Using Significant Digits in Test Data to Determine Conformance with Specifications
- E 1473 Test Methods for Chemical Analysis of Nickel, Cobalt, and High-Temperature Alloys

## 3. Terminology

### 3.1 Definitions of Terms Specific to This Standard:

**3.1.1** *bar* — material of rectangular (flats), hexagonal, or square solid section up to and including 10 in. (254 mm) in width and  $\frac{1}{8}$  in. (3.2 mm) and over in thickness in straight lengths.

**3.1.1.1** *Discussion* — Hot-worked rectangular bar in widths 10 in. (254 mm) and under may be furnished as hot-rolled plate with sheared or cut edges in accordance with Specification B 424, provided the mechanical property requirements of this specification are met.

**3.1.2** *rod* — Material of round solid section furnished in straight lengths.

## 4. Ordering Information

**4.1** It is the responsibility of the purchaser to specify all requirements that are necessary for the safe and satisfactory performance of material ordered under this specification. Examples of such requirements include, but are not limited to, the following:

- 4.1.1** ASTM designation and date of issue,
- 4.1.2** UNS number,
- 4.1.3** *Section* — Rod (round) or bar (square, hexagonal, or rectangular),
- 4.1.4** *Dimensions*, including length,
- 4.1.5** Condition (see Appendix X1),
- 4.1.6** Finish (see Appendix X1),
- 4.1.7** *Quantity* — Feet (or meters) or number of pieces,
- 4.1.8** *Certification* — Certification is required (Section 15),
- 4.1.9** *Samples for Product (Check) Analysis* — State whether samples for product (check) analysis should be furnished (see 5.2), and
- 4.1.10** *Purchaser Inspection* — If purchaser wishes to witness tests or inspection of material at place of manufacture, the purchase order must so state, indicating which test or inspections are to be witnessed (Section 13).

## 5. Chemical Composition

**5.1** The material shall conform to the composition limits specified in Table 1.

TABLE 1  
CHEMICAL REQUIREMENTS

Element	UNS N08825	UNS N08221
Nickel	38.0–46.0	39.0–46.0
Chromium	19.5–23.5	20.0–22.0
Iron <sup>A</sup>	22.0 min	balance
Manganese	1.0 max	1.0 max
Carbon	0.05 max	0.025 max
Copper	1.5–3.0	1.5–3.0
Silicon	0.5 max	0.5 max
Sulfur	0.03 max	0.03 max
Aluminum	0.2 max	0.2 max
Titanium	0.6–1.2	0.6–1.0
Molybdenum	2.5–3.5	5.0–6.5

<sup>A</sup> Element shall be determined arithmetically by difference.

**5.2** If a product (check) analysis is performed by the purchaser, it shall be done per B 880, and the material shall conform to the product (check) analysis variations defined in Table 1 of B 880.

## 6. Mechanical Properties and Other Requirements

**6.1 Mechanical Properties** — The material shall conform to the mechanical properties specified in Table 2.

## 7. Dimensions and Permissible Variations

**7.1 Diameter, Thickness, or Width** — The permissible variations from the specified dimensions as measured on the diameter or between parallel surfaces of cold-worked rod and bar shall be as prescribed in Table 3, and of hot-worked rod and bar as prescribed in Table 4.

**7.2 Out-of-Round** — Hot-worked rods and cold-worked rods (except “forging quality”) all sizes, in straight lengths, shall not be out-of-round by more than one half the total permissible variations in diameter shown in Table 3 and Table 4, except for hot-worked rods  $\frac{1}{2}$  in. (12.7 mm) in diameter and under, which may be out-of-round by the total permissible variations in diameter shown in Table 4.

**7.3 Corners** — Cold-worked bars will have practically exact angles and sharp corners.

**7.4 Machining Allowances for Hot-Worked Materials** — When the surfaces of hot-worked products are to be machined, the allowances prescribed in Table 5 are recommended for normal machining operations.

**7.5 Length** — The permissible variations in length of cold-worked and hot-worked rod and bar shall be as prescribed in Table 6.

**7.5.1** Rods and bars ordered to random or nominal lengths will be furnished with either cropped or saw-cut ends; material ordered to cut lengths will be furnished with square saw-cut or machined ends.

### 7.6 Straightness:

**7.6.1** The permissible variations in straightness of cold-worked rod and bar as determined by the departure from straightness shall be as prescribed in Table 7.

**7.6.2** The permissible variations in straightness of hot-worked rod and bar as determined by the departure from straightness shall be as specified in Table 8.

## 8. Workmanship, Finish, and Appearance

**8.1** The material shall be uniform in quality and condition, smooth, commercially straight or flat, and free of injurious imperfections.

## 9. Sampling

### 9.1 Lot — Definition:

**9.1.1** A lot for chemical analysis shall consist of one heat.

**9.1.2** A lot for mechanical properties testing shall consist of all material from the same heat, nominal diameter or thickness, and condition.

**9.1.2.1** Where material cannot be identified by heat, a lot shall consist of not more than 500 lb (227 kg)

TABLE 2  
MECHANICAL PROPERTIES (ROD AND BAR)

Alloy	Condition	Tensile Strength min, ksi (MPa)	Yield Strength 0.2 % offset, min, ksi (MPa)	Elongation in 2 in. or 50 mm or $4^D$ , min, %
UNS N08825	Annealed: Hot-finished, cold-drawn	85 (586)	35 (241)	30 <sup>A</sup>
UNS N08221	Forging Quality: All sizes annealed	<sup>B</sup>	<sup>B</sup>	<sup>B</sup>
		79 (544)	34 (235)	30

<sup>A</sup> Not applicable to diameters or cross sections under  $\frac{3}{32}$  in. (2.4 mm).

<sup>B</sup> Forging quality is furnished to chemical requirements and surface inspection only. No tensile properties are required.

**TABLE 3**  
PERMISSIBLE VARIATIONS IN DIAMETER OR DISTANCE BETWEEN PARALLEL SURFACES OF COLD-WORKED ROD AND BAR

Specified Dimension, in. (mm) <sup>A</sup>	Permissible Variations From Specified Dimension, in. (mm)	
	Plus	Minus
Rounds:		
1/16 (1.6) to 3/16 (4.8), excl	0	0.002 (0.05)
3/16 (4.8) to 1/2 (12.7), excl	0	0.003 (0.08)
1/2 (12.7) to 15/16 (23.8), incl	0.001 (0.03)	0.002 (0.05)
Over 15/16 (23.8) to 1 15/16 (49.2), incl	0.0015 (0.04)	0.003 (0.08)
Over 1 15/16 (49.2) to 2 1/2 (63.5), incl	0.002 (0.05)	0.004 (0.10)
Hexagons, squares, rectangles:		
1/2 (12.7) and less	0	0.004 (0.10)
Over 1/2 (12.7) to 7/8 (22.2), incl	0	0.005 (0.13)
Over 7/8 (22.2) to 1 1/4 (31.8), incl	0	0.007 (0.18)
Over 1 1/4 (31.8) to 2 (50.8), incl	0	0.009 (0.23)

<sup>A</sup> Dimensions apply to diameter of rounds, to distance between parallel surfaces of hexagons and squares, and separately to width and thickness of rectangles.

**TABLE 4**  
PERMISSIBLE VARIATIONS IN DIAMETER OR DISTANCE BETWEEN PARALLEL SURFACES OF HOT-WORKED ROD AND BAR

Specified Dimension, in. (mm) <sup>A</sup>	Permissible Variations From Specified Dimension, in. (mm)	
	Plus	Minus
Rod and bar, hot-worked:		
1 (25.4) and under	0.016 (0.41)	0.016 (0.41)
over 1 (25.4) to 2 (50.8), incl	0.031 (0.79)	0.016 (0.41)
over 2 (50.8) to 4 (101.6), incl	0.047 (1.19)	0.031 (0.79)
over 4 (101.6)	0.125 (3.18)	0.063 (1.60)
Rod, rough-turned or ground:		
Under 1 (25.4)	0.005 (0.13)	0.005 (0.13)
1 (25.4) and over	0.031 (0.79)	0
Forging quality rod: <sup>B</sup>		
Under 1 (25.4)	0.005 (0.13)	0.005 (0.13)
1 (25.4) and over	0.031 (0.79)	0

<sup>A</sup> Dimensions apply to diameter of rods, to distance between parallel surfaces of hexagons and squares, and separately to width and thickness of rectangles.

<sup>B</sup> Spot grinding is permitted to remove minor surface imperfections. The depth of these spot ground areas shall not exceed 3% of the diameter of the rod.

of material in the same size and condition. A single piece weighing over 500 lb shall be considered as one lot.

**9.2 Test Material Selection:**

**9.2.1 Chemical Analysis** — Representative samples from each lot shall be taken during pouring or subsequent processing.

**9.2.1.1 Product (check) analysis** shall be wholly the responsibility of the purchaser.

**9.2.2 Mechanical Properties** — Samples of the material to provide test specimens for mechanical properties shall be taken from such locations in each lot as to be representative of that lot.

**10. Number of Tests**

**10.1 Chemical Analysis** — One test per lot.

**10.2 Tension** — One test per lot.

**11. Specimen Preparation**

**11.1 Tension test specimens** shall be taken from material in the final condition and tested in the direction of fabrication.

**11.1.1** All rod and bar shall be tested in full cross-section size when possible. When a full cross-section size test cannot be performed, the largest possible round specimen shown in Test Methods E 8 shall be used. Longitudinal strip specimens shall be prepared in accordance with Test Methods E 8 for rectangular bar up to 1/2 in. (12.7 mm), inclusive, in thicknesses which are too wide to be pulled full size.

**12. Test Methods**

**12.1** The chemical composition and mechanical and other properties of the material as enumerated in this specification shall be determined, in case of disagreement, in accordance with the following ASTM standards.

Test	ASTM Designation
Chemical analysis	E 1473
Tension	E 8
Rounding procedure	E 29

TABLE 5  
NORMAL MACHINING ALLOWANCES FOR HOT-WORKED MATERIAL

Finished-Machined Dimensions for Finishes As Indicated Below, in. (mm) <sup>A</sup>	Normal Machining Allowance, in. (mm)			
	On Diameter, for Rods	Distance Between Parallel Surfaces, for Hexagonal and Square Bars	For Rectangular Bar	
			On Thickness	On Width
Hot-worked: <sup>B</sup>				
Up to $\frac{7}{8}$ (22.2), incl	$\frac{1}{8}$ (3.2)	$\frac{1}{8}$ (3.2)	$\frac{1}{8}$ (3.2)	$\frac{3}{16}$ (4.8)
Over $\frac{7}{8}$ to $1\frac{7}{8}$ (22.2 to 47.6), incl	$\frac{1}{8}$ (3.2)	$\frac{3}{16}$ (4.8)	$\frac{1}{8}$ (3.2)	$\frac{3}{16}$ (4.8)
Over $1\frac{7}{8}$ to $2\frac{7}{8}$ (47.6 to 73.0), incl	$\frac{3}{16}$ (4.8)	$\frac{1}{4}$ (6.4)	...	$\frac{3}{16}$ (4.8)
Over $2\frac{7}{8}$ to $3\frac{13}{16}$ (73.0 to 96.8), incl	$\frac{1}{4}$ (6.4)	...	...	$\frac{3}{16}$ (4.8)
Over $3\frac{13}{16}$ (96.8)	$\frac{1}{4}$ (6.4)	...	...	$\frac{3}{8}$ (9.5)
Hot-worked rods, rough-turned or rough ground: <sup>C</sup>				
$1\frac{5}{16}$ to 4 (23.8 to 101.6), incl in diameter	$\frac{1}{16}$ (1.6)	...	...	...
Over 4 to 12 (101.6 to 304.8), incl in diameter	$\frac{1}{8}$ (3.2)	...	...	...

<sup>A</sup> Dimensions apply to diameter of rods, to distance between parallel surfaces of hexagonal and square bar, and separately to width and thickness of rectangular bar.

<sup>B</sup> The allowances for hot-worked material in Table 5 are recommended for rods machined in lengths of 3 ft (0.91 m) or less and for bars machined in lengths of 2 ft (0.61 m) or less. Hot-worked material to be machined in longer lengths should be specified showing the finished cross-sectional dimension and the length in which the material will be machined in order that the manufacturer may supply material with sufficient oversize, including allowance for out-of-straightness.

<sup>C</sup> Applicable to 3 ft (0.91 m) max length.

**12.2** For purposes of determining compliance with the specified limits for requirements of the properties listed in the following table, an observed or calculated value shall be rounded as indicated below, in accordance with the rounding method of Practice E 29:

Test	Rounded unit for observed or calculated value
Chemical composition and tolerances (when expressed in decimals)	nearest unit in the last righthand place of figures of the specified limit. If two choices are possible, as when the digits dropped are exactly a 5, or a 5 followed only by zeros, choose the one ending in an even digit, with zero defined as an even digit.
Tensile strength and yield strength	nearest 1000 psi (6.9 MPa)
Elongation	nearest 1%

### 13. Inspection

**13.1** Inspection of the material shall be made as agreed upon between the manufacturer and the purchaser as part of the purchase contract.

### 14. Rejection and Reheating

**14.1** Material tested by the purchaser that fails to conform to the requirements of this specification may be

rejected. Rejection should be reported to the producer or supplier promptly and in writing. In case of dissatisfaction with the results of the test, the producer or supplier may make claim for a reheating.

### 15. Certification

**15.1** A manufacturer's certification shall be furnished to the purchaser stating that the material has been manufactured, tested, and inspected in accordance with this specification and that the test results on representative samples meet specification requirements. A report of the test results shall be furnished.

### 16. Product Marking

**16.1** The following information shall be marked on the material or included on the package, or on a label or tag attached thereto: The name of the material or UNS number; heat number; condition (temper); this specification number; the size; gross, tare, and net weight; consignor and consignee address; contract or order number; or such other information as may be defined in the contract or order.

**TABLE 6**  
**PERMISSIBLE VARIATIONS IN LENGTH OF RODS AND BARS**

Random mill lengths:	
Hot-worked	6 to 24 ft (1.83 to 7.31 m) long with not more than 25 weight % between 6 and 9 ft (1.83 and 2.74 m) <sup>A</sup>
Cold-worked	6 to 20 ft (1.83 to 6.1 m) long with not more than 25 weight % between 6 and 10 ft (1.83 and 3.05 m).
Multiple lengths	Furnished in multiples of a specified unit length, within the length limits indicated above. For each multiple, an allowance of 1/4 in. (6.4 mm) will be made for cutting, unless otherwise specified. At the manufacturer's option, individual specified unit lengths may be furnished.
Nominal lengths	Specified nominal lengths having a range of not less than 2 ft (610 mm) with no short lengths allowed. <sup>B</sup>
Cut lengths	A specified length to which all rods and bars will be cut with a permissible variation of plus 1/8 in. (3.2 mm) minus 0 for sizes 8 in. (203 mm) and less in diameter or distance between parallel surfaces. For larger sizes, the permissible variation shall be +1/4 in. (6.4 mm), -0.

<sup>A</sup> For hot-worked sections weighing over 25 lb/ft (37 kg/m) and for smooth forged products, all sections, short lengths down to 2 ft (610 mm) may be furnished.

<sup>B</sup> For cold-worked rods and bars under 1/2 in. (12.7 mm) in diameter or distance between parallel surfaces ordered to nominal or stock lengths with a 2-ft (610-mm) range, at least 93% of such material shall be within the range specified; the balance may be in shorter lengths but in no case shall lengths less than 4 ft (1220 mm) be furnished.

**TABLE 7**  
**PERMISSIBLE VARIATIONS IN STRAIGHTNESS OF COLD-WORKED RODS AND BARS**

Specified Diameter or Distance Between Parallel Surfaces, in (mm) <sup>A</sup>	Permissible Variations in Lengths Indicated, in. (mm)
Rounds:	Depth of chord:
1/2 (12.7) to 2 1/2 (63.5), incl	0.030 (0.76) per ft (305 mm) of length
Hexagons, squares, rectangles:	
1/2 (12.7) to 2 (50.8), incl	0.030 (0.76) per ft (305 mm) of length

<sup>A</sup> Material under 1/2 in. (12.7 mm) shall be reasonably straight and free of sharp bends and kinks.

TABLE 8  
PERMISSIBLE VARIATIONS IN STRAIGHTNESS OF HOT-WORKED RODS AND BARS<sup>A</sup>

Finish	Permissible Variations, in./ft (mm/m) <sup>B</sup>
Rods and bars, hot-worked	0.050 (4.2) <sup>C</sup>
Rounds—hot-worked, rough ground or rough turned	0.050 (4.2) <sup>C</sup>

<sup>A</sup> Not applicable to forging quality.

<sup>B</sup> Material under  $\frac{1}{2}$  in. (12.7 mm) shall be reasonably straight and free of sharp bends and kinks.

<sup>C</sup> The maximum curvature (depth of chord) shall not exceed the values indicated multiplied by the length in feet.

ASMENORMDOC.COM : Click to view the full PDF of ASME BPVC.II.B (ASME BPVC Section II part B) 2025

## APPENDIX

## (Nonmandatory Information)

**X1. PROCURABLE CONDITIONS AND FINISHES**

**X1.1** The various conditions and finishes in which rod and bar are procurable are as follows:

**X1.1.1** *Hot-Worked, Annealed* — Soft, with a tightly adherent dark oxide.

**X1.1.2** *Hot-worked, Annealed, and Pickled* — Same as X1.1.1 except descaled for removal of mill oxide. Provides for better surface inspection than does hot-worked, annealed material and often employed where welding is involved where removal of mill oxide is desired.

NOTE X1.1 — Annealing prior to pickling may be required in order to reduce the mill oxide since uniform pickling of an unreduced oxide is difficult.

**X1.1.3** *Hot-Worked, Annealed, and Rough-Ground* — Similar to X1.1.1 except rough-ground.

**X1.1.4** *Hot-Worked, Annealed, and Rough-Turned* — Similar to X1.1.1 except rough-turned with a broad nosed

tool similar to a bar peeling operation and thus may not be straight. Intended generally for machining where an overhauled surface is desired, essentially for machined step down shafts or parts machined in short lengths of 3 ft (0.91 m) or less.

**X1.1.5** *Hot-Worked, Forging Quality* — Rough-turned and spot-ground as necessary, for sizes 1 in. (25.4 mm) in diameter and over; rough-ground and spot-ground for sizes under 1 in. in diameter. Material is selected from heats of known, good hot malleability.

NOTE X1.2 — For sizes  $2\frac{1}{2}$  in. (63.5 mm) in diameter and less, cold-worked rod may be used also for forging by virtue of the fact such rod have been overhauled for removal of mechanical surface defects prior to cold-working. In such cases, the user should run pilot forging tests to ensure himself that such material has the desired hot malleability range.

**X1.1.6** *Cold-Worked, Annealed, and Pickled* — Hot-worked, overhauled, cold-worked, annealed, descaled, and straightened. Annealed for softness and with a dull matte finish.

**SPECIFICATION FOR NICKEL-MOLYBDENUM-  
CHROMIUM-IRON ALLOYS (UNS N10003, UNS N10242)  
PLATE, SHEET, AND STRIP**



**SB-434**

(Identical with ASTM Specification B434-06(2011) except that certification and test reports have been made mandatory.)

# Standard Specification for Nickel-Molybdenum-Chromium-Iron Alloys (UNS N10003, UNS N10242) Plate, Sheet, and Strip

## 1. Scope

1.1 This specification covers nickel-molybdenum-chromium-iron alloys (UNS N10003 and UNS N10242) plate, sheet, and strip for use in general corrosive service.

1.2 The following products are covered under this specification:

1.2.1 *Sheet and Strip*—Hot or cold rolled, annealed, and descaled unless annealing is performed in an atmosphere yielding a bright finish.

1.2.2 *Plate*—Hot rolled, annealed, and descaled.

1.3 The values stated in SI units are to be regarded as the standard. The values given in parentheses are for information only.

1.4 *This standard does not purport to address all of the safety concerns, if any, associated with its use. It is the responsibility of the user of this standard to become familiar with all hazards including those identified in the appropriate Material Safety Data Sheet (MSDS) for this product/material as provided by the manufacturer, to establish appropriate safety and health practices, and determine the applicability of regulatory limitations prior to use.*

## 2. Referenced Documents

2.1 *ASTM Standards:*

B906 Specification for General Requirements for Flat-Rolled Nickel and Nickel Alloys Plate, Sheet, and Strip

## 3. Terminology

3.1 *Definitions of Terms Specific to This Standard:*

3.1.1 *plate, n*—material  $\frac{3}{16}$  in. (4.76 mm) and over in thickness.

3.1.2 *sheet and strip, n*—material under  $\frac{3}{16}$  in. (4.76 mm) in thickness.

## 4. General Requirements

4.1 Material furnished under this specification shall conform to the applicable requirements of Specification B906 unless otherwise provided herein.

## 5. Ordering Information

5.1 It is the responsibility of the purchaser to specify all requirements that are necessary for the safe and satisfactory performance of material ordered under this specification. Examples of such requirements include but are not limited to the following:

5.1.1 *Dimensions*—Thickness (in decimals of an inch), width, and length (inch or fraction of an inch),

5.1.2 DELETED

5.1.3 *Purchase Inspection*—State which tests or inspections are to be witnessed, and

5.1.4 *Samples for Product (Check) Analysis*—State whether samples shall be furnished.

## 6. Chemical Composition

6.1 The material shall conform to the requirements as to chemical composition prescribed in Table 1.

6.2 If a product (check) analysis is made by the purchaser, the material shall conform to the requirements specified in Table 1 subject to the permissible tolerances in Specification B906.

## 7. Mechanical Properties and Other Requirements

7.1 *Tensile Properties*—The material shall conform to the room temperature tensile properties prescribed in Table 2.

7.2 *Grain Size for Sheet and Strip*—Sheet and strip shall conform to the grain size requirements given in Table 3.

TABLE 1 Chemical Requirements

Element	Composition, %	
	UNS N10242	UNS N10003
Chromium	7.0-9.0	6.0-8.0
Iron, max	2.0	5.0
Carbon	0.03 max	0.04-0.08
Silicon, max	0.80	1.00
Cobalt, max	1.00	0.20
Manganese, max	0.80	1.00
Tungsten, max	...	0.50
Vanadium, max	...	0.50
Molybdenum	24.0-26.0	15.0-18.0
Phosphorus, max	0.030	0.015
Sulfur, max	0.015	0.020
Aluminum plus titanium, max	...	0.50
Copper, max	0.50	0.35
Boron, max	0.006	0.010
Nickel	remainder	remainder
Aluminum, max	0.50	...

TABLE 2 Mechanical Properties for Plate and Sheet

UNS	Tensile Strength, min, ksi (MPa)	Yield Strength (0.2 % Offset), min, ksi (MPa)	Elongation in 2 in. (50.8 mm) or 4D <sup>A</sup> min, %
N10003	100 (690)	40 (280)	40
N10242	105 (725)	45 (310)	40

<sup>A</sup> D refers to the diameter of the tension specimen.

TABLE 3 Grain Size for Annealed Sheets

Thickness, in. (mm)	ASTM Micrograin Size Number, max	Average Grain Diameter, max, in (mm)
0.125 (3.175) and under	3.0	0.0050 (0.127)
Over 0.125 (3.175)	1.5	0.0084 (0.214)

## 8. Dimensions and Permissible Variations

8.1 *Weight*—For calculation of mass or weight, the following densities shall be used:

Alloy	lb/in <sup>3</sup>	g/cm <sup>3</sup>
N10003	0.317	8.78
N10242	0.327	9.05

8.2 *Thickness*:

8.2.1 *Plate*—The permissible variations in thickness of plate shall be as prescribed in Table A2.1 in Specification B906.

8.2.2 *Sheet and Strip*—The permissible variations in thickness of sheet and strip shall be as prescribed in Table A2.2 in Specification B906. The thickness shall be measured with the micrometer spindle  $\frac{3}{8}$  in. (9.525 mm) or more from any edge

for material 1 in. (25.4 mm) or over in width and at any place on material under 1 in. in width.

8.3 *Width*:

8.3.1 *Plate*—The permissible variations in width of rectangular plates shall be as prescribed in Table A2.3 in Specification B906.

8.3.2 *Sheet and Strip*—The permissible variations in width for sheet and strip shall be as prescribed in Table A2.4 in Specification B906.

8.4 *Length*:

8.4.1 *Plate*—Permissible variations in the length of rectangular plate shall be as prescribed in Table A2.3 in Specification B906.

8.4.2 *Sheet and Strip*—Sheet and strip may be ordered to cut lengths, in which case a variation of  $\frac{1}{8}$  in. (3.175 mm) over the specified length shall be permitted, with a 0 minus tolerance.

8.5 *Straightness*:

8.5.1 The edgewise curvature (depth of chord) of flat sheet, strip, and plate shall not exceed the product of 0.05 in. multiplied by the length in feet (0.04 mm) multiplied by the length in centimetres.

8.5.2 Straightness for coiled strip is subject to agreement between the manufacturer and the purchaser.

8.6 *Squareness (Sheet)*—For sheets of all thicknesses and widths of 6 in. (152.4 mm) or more, the angle between adjacent sides shall be  $90 \pm 0.15$  deg ( $\frac{1}{16}$  in. in 24 in. or 2.6 mm/m).

8.7 *Flatness*—Plate, sheet, and strip shall be commercially flat.

8.8 *Edges*:

8.8.1 Plate shall have sheared or abrasive cut edges.

8.8.2 Sheet and strip shall have sheared or slit edges.

## 9. Product Marking

9.1 Each plate, sheet, or strip shall be marked on one face with the specification number, heat number, manufacturer's identification, and size. The markings shall have no deleterious effect on the material or its performance and shall be sufficiently stable to withstand normal handling.

9.2 Each bundle or shipping container shall be marked with the name of the material; this specification number; the size; gross, tare, and net weight; consignor and consignee address; contract or order number; and such other information as may be defined in the contract or order.

## 10. Keywords

10.1 plate; sheet; strip; UNS N10003; UNS N10242

**APPENDIX**

(Nonmandatory Information)

**X1. HEAT TREATMENT**

X1.1 Proper heat treatment during or subsequent to fabrication is necessary for optimum performance, and the manufacturer shall be consulted for details.

ASMENORMDOC.COM : Click to view the full PDF of ASME BPVC.II.B (ASME BPVC Section II part B) 2025

# SPECIFICATION FOR UNS N06002, UNS N06230, UNS N12160, AND UNS R30556 PLATE, SHEET, AND STRIP



SB-435

(Identical with ASTM Specification B435-06(2016) except that certification and test reports have been made mandatory.)

# Specification for UNS N06002, UNS N06230, UNS N12160, and UNS R30556 Plate, Sheet, and Strip

## 1. Scope

1.1 This specification covers alloys UNS N06002, UNS N06230, UNS N12160, and UNS R30556 in the form of rolled plate, sheet, and strip for heat-resisting and general corrosive service.

1.2 The following products are covered under this specification:

1.2.1 *Sheet and Strip*—Hot- or cold-rolled, annealed, and descaled unless solution annealing is performed in an atmosphere yielding a bright finish.

1.2.2 *Plate*—Hot-rolled, solution-annealed, and descaled.

1.3 The values stated in inch-pound units are to be regarded as standard. The values given in parentheses are mathematical conversions to SI units that are provided for information only and are not considered standard.

1.4 *This standard does not purport to address all of the safety concerns, if any, associated with its use. It is the responsibility of the user of this standard to become familiar with all hazards including those identified in the appropriate Safety Data Sheet (SDS) for this product/material as provided by the manufacturer; to establish appropriate safety and health practices, and determine the applicability of regulatory limitations prior to use.*

## 2. Referenced Documents

### 2.1 ASTM Standards:

B906 Specification for General Requirements for Flat-Rolled Nickel and Nickel Alloys Plate, Sheet, and Strip

E527 Practice for Numbering Metals and Alloys in the Unified Numbering System (UNS)

## 3. Terminology

### 3.1 Definitions of Terms Specific to This Standard:

3.1.1 *plate, n*—material  $\frac{3}{16}$  in. (4.76 mm) and over in thickness.

3.1.2 *sheet and strip, n*—material under  $\frac{3}{16}$  in. (4.76 mm) in thickness.

## 4. General Requirements

4.1 Material furnished under this specification shall conform to the applicable requirements of Specification B906 unless otherwise provided herein.

## 5. Ordering Information

5.1 It is the responsibility of the purchaser to specify all requirements that are necessary for material ordered under this specification. Examples of such requirements include, but are not limited to the following:

5.1.1 *Alloy*,

5.1.2 *Dimensions*—Thickness (in decimals of an inch), width, and length (inch or fraction of an inch),

5.1.3 *Certification*—Certification and test reports are required,

5.1.4 *Optional Requirement*—Plate; state how plate is to be cut (Specification B906, Table titled Permissible Variations in width and Length of Sheared, Torch-Cut, or Abrasive-Cut Rectangular Plate),

5.1.5 *Purchase Inspection*—State which tests or inspections are to be witnessed (Specification B906, section on Inspection), and

5.1.6 *Samples for Product (Check) Analysis*—State whether samples should be furnished (Specification B906, section on Sampling).

## 6. Chemical Composition

6.1 The material shall conform to the requirements as to chemical composition prescribed in Table 1.

TABLE 1 Chemical Requirements

Element	Composition Limits, %			
	UNS N06002	UNS N06230	UNS R30556	UNS N12160
Nickel	remainder	remainder	19.0–22.5	remainder
Iron	17.0–20.0	3.0 max	remainder	3.5 max
Chromium	20.5–23.0	20.0–24.0	21.0–23.0	26.0–30.0
Cobalt	0.5–2.5	5.0 max	16.0–21.0	27.0–33.0
Molybdenum	8.0–10.0	1.0–3.00	2.5–4.0	1.0 max
Tungsten	0.2–1.0	13.0–15.0	2.0–3.5	1.0 max
Carbon	0.05–0.15	0.05–0.15	0.05–0.15	0.15 max
Silicon	1.00 max	0.25–0.75	0.20–0.80	2.4–3.0
Manganese	1.00 max	0.30–1.00	0.50–2.00	1.5 max
Phosphorus	0.04 max	0.030 max	0.04 max	0.030 max
Sulfur	0.03 max	0.015 max	0.015 max	0.015 max
Columbium (N6)	...	...	0.30 max	1.0 max
Tantalum	...	...	0.30–1.25	...
Aluminum	...	0.50 max	0.10–0.50	...
Zirconium	...	...	0.001–0.10	...
Lanthanum	...	0.005–0.050	0.005–0.10	...
Nitrogen	...	...	0.10–0.30	...
Boron	...	0.015 max	0.02 max	...
Titanium	...	...	...	0.20–0.80

TABLE 2 Mechanical Property Requirements

UNS	Tensile Strength, min, ksi (MPa)	Yield Strength (0.2 % Offset), min, ksi (MPa)	Elongation in 2 in. (50.8 mm) or 4D, <sup>A</sup> min, %
N06002	95 (655)	35 (240)	35
N06230 <sup>B</sup>	110 (760)	45 (310)	40
R30556 <sup>C</sup>	100 (690)	45 (310)	40
N12160 <sup>D</sup>	90 (620)	35 (240)	40

<sup>A</sup> D refers to the diameter of the tension specimen.

<sup>B</sup> Solution annealed at a temperature between 2200 and 2275°F (1204 and 1246°C) followed by a water quench or rapidly cooled by other means.

<sup>C</sup> Solution annealed at 2100°F (1150°C) minimum.

<sup>D</sup> Solution annealed at 1950°F (1065°C) minimum.

TABLE 3 Grain Size for Annealed Sheet

Thickness, in. (mm)	ASTM Micrograin Size Number, max	Average Grain, Diameter, max, in. (mm)
0.125 (3.175) and under	3.0	0.0050 (0.127)
Over 0.125 (3.175)	1.5	0.0084 (0.214)

6.2 If a product (check) analysis is made by the purchaser, the material shall conform to the requirements specified in Table 1 and Specification B906.

## 7. Mechanical Properties and Other Requirements

7.1 *Tensile Properties*—The material shall conform to the room temperature tensile properties prescribed in Table 2.

7.2 *Grain Size for Sheet and Strip*:

7.2.1 Annealed alloys UNS N06002, UNS N06230, and UNS R30556 sheet and strip shall conform to the grain size requirements given in Table 3.

7.2.2 Annealed alloy UNS N12160 shall conform to an average grain size of ASTM No. 5 or coarser.

## 8. Dimensions, Mass, and Permissible Variations

8.1 *Weight*—For calculations of mass or weight, the following densities shall be used:

Alloy	lb/in. <sup>3</sup>	Density (g/cm <sup>3</sup> )
N06002	0.297	(8.23)
N06230	0.324	(8.97)
R30556	0.297	(8.23)
N12160	0.292	(8.08)

8.2 *Thickness*:

8.2.1 *Sheet and Strip*—The thickness shall be measured with the micrometer spindle  $\frac{3}{8}$  in. (9.525 mm) or more from any edge for material 1 in. (25.4 mm) or over in width and at any place on material under 1 in. in width.

8.3 *Length*:

8.3.1 *Sheet and Strip*—Sheet and strip may be ordered to cut lengths, in which case a variation of  $\frac{1}{8}$  in. (3.175 mm) over the specified length shall be permitted, with a 0 minus tolerance.

8.4 *Straightness*:

8.4.1 The edgewise curvature (depth of chord) of flat sheet, strip, and plate shall not exceed the product of 0.05 in. multiplied by the length in feet (0.04 mm multiplied by the length in centimetres).

8.4.2 Straightness for coiled strip is subject to agreement between the manufacturer and the purchaser.

8.5 *Squareness (Sheet)*—For sheets of all thicknesses and widths of 6 in. (152.4 mm) or more, the angle between adjacent sides shall be  $90 \pm 0.15^\circ$  ( $\frac{1}{16}$  in. in 24 in. or 2.6 mm/m).

8.6 *Flatness*—Plate, sheet, and strip shall be commercially flat.

8.7 *Edges*:

8.7.1 Plates shall have sheared, abrasive-cut or plasma-torch-cut edges as specified.

8.7.2 Sheet and strip shall have sheared or slit edges.

## 9. Product Marking

9.1 Each plate, sheet, or strip shall be marked on one face with the specification number, alloy, heat number, manufacturer's identification, and size. The markings shall have no deleterious effect on the material or its performance and shall be sufficiently stable to withstand normal handling.

9.2 Each bundle or shipping container shall be marked with the name of the material; this specification number; alloy; the size; gross, tare, and net weight; consignor and consignee address; contract or order number; and such other information as may be defined in the contract or order.

#### 10. Keywords

10.1 plate; sheet; strip; UNS N06002; UNS N06230; UNS N12160; UNS R30556

### APPENDIX

(Nonmandatory Information)

#### X1. HEAT TREATMENT

X1.1 Proper heat treatment during or subsequent to fabrication is necessary for optimum performance, and the manufacturer shall be consulted for details.

ASME BPVC Section II part B) 2025

ASME BPVC.II.B (ASME BPVC Section II part B) 2025

ASMENORMDOC.COM : Click to view the full PDF of ASME BPVC.II.B (ASME BPVC Section II part B) 2025

**SPECIFICATION FOR NICKEL-CHROMIUM-  
MOLYBDENUM-COLUMBIUM ALLOY (UNS N06625)  
AND NICKEL-CHROMIUM-MOLYBDENUM-SILICON  
ALLOY (UNS N06219) PLATE, SHEET, AND STRIP**



**SB-443**

(Identical with ASTM Specification B443-00(2014) except that certification has been made mandatory.)

# SPECIFICATION FOR NICKEL-CHROMIUM- MOLYBDENUM-COLUMBIUM ALLOY (UNS N06625) AND NICKEL-CHROMIUM-MOLYBDENUM-SILICON ALLOY (UNS N06219) PLATE, SHEET, AND STRIP



SB-443

[Identical with ASTM Specification B 443-00(2014) except that certification has been made mandatory.]

## 1. Scope

**1.1** This specification covers rolled nickel-chromium-molybdenum-columbium alloy (UNS N06625) and nickel-chromium-molybdenum-silicon alloy (UNS N06219) plate, sheet, and strip.

**1.1.1** Alloy UNS N06625 products are furnished in two grades of different heat-treated conditions:

**1.1.1.1** *Grade 1 (Annealed)*— Material is normally employed in service temperatures up to 1100°F (593°C).

**1.1.1.2** *Grade 2 (Solution Annealed)*— Material is normally employed in service temperatures above 1100°F (593°C) when resistance to creep and rupture is required.

NOTE 1 — Hot-working or reannealing may change properties significantly, depending on working history and temperatures.

**1.1.2** Alloy UNS N06219 is supplied in solution annealed condition only.

**1.2** The values stated in inch-pound units are to be regarded as the standard. The values given in parentheses are for information only.

## 2. Referenced Documents

### 2.1 ASTM Standards:

- B 446 Specification for Nickel-Chromium-Molybdenum-Columbium Alloy (UNS N06625) Rod and Bar
- B 880 Specification for General Requirements for Chemical Check Analysis Limits for Nickel, Nickel Alloys and Cobalt Alloys
- E 8 Test Methods for Tension Testing of Metallic Materials
- E 29 Practice for Using Significant Digits in Test Data to Determine Conformance with Specifications
- E 354 Test Methods for Chemical Analysis of High-Temperature, Electrical, Magnetic, and Other Similar Iron, Nickel, and Cobalt Alloys

E 1473 Test Methods for Chemical Analysis of Nickel, Cobalt, and High-Temperature Alloys

## 3. Terminology

**3.1** *Definitions of Terms Specific to This Standard*— The terms given in Table 1 shall apply.

## 4. Ordering Information

**4.1** It is the responsibility of the purchaser to specify all requirements that are necessary for the safe and satisfactory

TABLE 1  
PRODUCT DESCRIPTION

Product	Thickness, in. (mm)	Width, in. (mm)
Hot-rolled plate <sup>A</sup>	$\frac{3}{16}$ (4.8) and over (Tables 4 and 5)	(Table 7) <sup>A</sup>
Cold-rolled plate <sup>B</sup>	$\frac{3}{16}$ to $\frac{3}{8}$ (4.8 to 9.5), incl (Table 4)	(Table 7)
Hot-rolled sheet <sup>B</sup>	0.018 to 0.250 (0.46 to 6.4), incl (Table 6)	(Table 9)
Cold-rolled sheet <sup>C</sup>	0.018 to 0.250 (0.46 to 6.4), incl (Table 6)	(Table 9)
Cold-rolled strip <sup>C</sup>	0.005 to 0.250 (0.13 to 6.4), incl (Table 6)	(Table 9)

<sup>A</sup> Hot-rolled plate, in widths 10 in. (254 mm) and under, may be furnished as hot-finished rectangles with sheared or cut edges in accordance with Specification B 446 provided the mechanical property requirements of this specification are met.

<sup>B</sup> Material  $\frac{3}{16}$  to  $\frac{1}{4}$  in. (4.8 to 6.4 mm), incl, in thickness may be furnished as sheet or plate provided the material meets the specification requirements for the condition ordered.

<sup>C</sup> Material under 48 in. (1219 mm) in width may be furnished as sheet or strip provided the material meets the specification requirements for the condition ordered.

TABLE 2  
CHEMICAL REQUIREMENTS

Element	Composition Limits, %	
	N06625	N06219
Carbon	0.10 max	0.05 max
Manganese	0.50 max	0.50 max
Silicon	0.50 max	0.70–1.10
Phosphorus	0.015 max	0.020 max
Sulfur	0.015 max	0.010 max
Chromium	20.0 min 23.0 max	18.0–22.0 ...
Columbium + tantalum	3.15 min 4.15 max	... ...
Cobalt (if determined)	1.0 max	1.0 max
Molybdenum	8.0 min 10.0 max	7.0–9.0 ...
Iron	5.0 max	2.0–4.0
Aluminum	0.40 max	0.50 max
Titanium	0.40 max	0.50 max
Copper	...	0.50 max
Nickel <sup>4</sup>	58.0 min	Bal.

<sup>4</sup> Element shall be determined arithmetically by difference.

performance of material ordered under this specification. Examples of such requirements include, but are not limited to, the following:

**4.1.1** ASTM designation,

**4.1.2** Alloy name or UNS number,

**4.1.3** *Condition* — See 1.1.1, 1.1.2 and Appendix X1,

**4.1.3.1** If neither grade of N06625 is specified, Grade 1 will be supplied,

**4.1.4** *Finish* — Appendix X1,

**4.1.5** *Dimensions* — Thickness, width, and length,

**4.1.6** *Quantity*,

**4.1.7** *Optional Requirements*:

**4.1.7.1** *Sheet and Strip* — Whether to be furnished in coil, in cut straight lengths, or in random straight lengths,

**4.1.7.2** *Plate* — How plate is to be cut (see 7.2.1 and 7.3.2),

**4.1.8** *Certification* — Certification is required (Section 15),

**4.1.9** *Samples for Product (Check) Analysis* — Whether samples for product (check) analysis should be furnished (see 5.2), and

**4.1.10** *Purchaser Inspection* — If the purchaser wishes to witness tests or inspection of material at place of manufacture, the purchase order must so state, indicating which tests or inspections are to be witnessed (Section 13).

## 5. Chemical Composition

**5.1** The material shall conform to the composition limits specified in Table 2.

**5.2** If a product (check) analysis is performed by the purchaser, the material shall conform to the product (check) analysis variations as prescribed by B 880.

## 6. Mechanical Properties and Other Requirements

**6.1** *Mechanical Properties* — The material shall conform to the heat treatment and room temperature tensile properties prescribed in Table 3.

## 7. Dimensions and Permissible Variations

### 7.1 Thickness and Weight:

**7.1.1** *Plate* — For plate up to 2 in. (50.8 mm), inclusive, in thickness, the permissible variations under the specified thickness and permissible excess in overweight shall not exceed the amounts prescribed in Table 4.

**7.1.1.1** For use with Table 4, plate shall be assumed to weigh 0.305 lb/in.<sup>3</sup> (8.442 g/cm<sup>3</sup>).

**7.1.2** *Plate* — For plate over 2 in. (50.8 mm) in thickness, the permissible variations over the specified thickness shall not exceed the amounts prescribed in Table 5.

**7.1.3** *Sheet and Strip* — The permissible variations in thickness of sheet and strip shall be as prescribed in Table 6. The thickness of strip and sheet shall be measured with the micrometer spindle  $\frac{3}{8}$  in. (9.5 mm) or more from either edge for material 1 in. (25.4 mm) or over in width and at any place on the strip under 1 in. (25.4 mm) in width.

### 7.2 Width or Diameter:

**7.2.1** *Plate* — The permissible variations in width of rectangular plates and diameter of circular plates shall be as prescribed in Table 7 and Table 8.

**7.2.2** *Sheet and Strip* — The permissible variations in width for sheet and strip shall be as prescribed in Table 9.

### 7.3 Length:

**7.3.1** Sheet and strip of all sizes may be ordered to cut lengths, in which case a variation of  $\frac{1}{8}$  in. (3.2 mm) over the specified length shall be permitted.

**7.3.2** Permissible variations in length of rectangular plate shall be as prescribed in Table 10.

### 7.4 Straightness:

**7.4.1** The edgewise curvature (depth of chord) of flat sheet, strip, and plate shall not exceed 0.05 in. (1.27 mm) multiplied by the length in feet (0.04 mm multiplied by the length in centimeters).

**7.4.2** Straightness for coiled material is subject to agreement between the manufacturer and the purchaser.

TABLE 3  
ROOM TEMPERATURE TENSILE PROPERTIES AND HEAT TREATMENT  
(All Thicknesses and Sizes Unless Otherwise Indicated)

Product	Tensile Strength, min, ksi (MPa)	Yield Strength <sup>A</sup> (0.2% Offset), min, ksi (MPa)	Elongation in 2 in. or 50 mm (or 4D), min, % <sup>B</sup>
Grade 1 UNS N06625 (Annealed) <sup>C</sup>			
Cold-rolled sheet and strip	120 (827)	60 (414)	30
Hot-rolled sheet and hot-rolled plate up to 2.75 in. (70 mm), incl	110 (758)	55 (379)	30
Cold-rolled plate up to 0.375 in. (9.5 mm), incl	110 (758)	55 (379)	30
Grade 2 UNS N06625 (Solution Annealed) <sup>D</sup>			
Cold-rolled sheet and strip, hot-rolled sheet, cold-rolled plate, and hot-rolled plate	100 (690)	40 (276)	30
All UNS N06219 (Solution Annealed)			
All plate, sheet, and strip	96 (660)	39 (270)	30

<sup>A</sup> Yield strength requirements do not apply to material under 0.020 in. (0.508 mm) in thickness.

<sup>B</sup> Elongation requirements do not apply to material under 0.010 in. (0.254 mm) in thickness.

<sup>C</sup> Annealed at 1600°F (871°C) minimum.

<sup>D</sup> Solution annealed at 2000°F (1093°C) minimum, with or without subsequent stabilization anneal at 1800°F (982°C) minimum to increase resistance to sensitization.

### 7.5 Edges:

**7.5.1** Sheet and strip shall have sheared or slit edges.

**7.5.2** Plate shall have sheared or cut (machined, abrasive cut, powder cut, or inert arc cut) edges, as specified.

**7.6 Squareness (Sheet)** — For sheets of all thicknesses, the angle between adjacent sides shall be  $90 \pm 0.15^\circ$  ( $\frac{1}{16}$  in. in 24 in.) (1.6 mm in 610 mm).

**7.7 Flatness** — Standard flatness tolerances for plate shall conform to the requirements of Table 11.

## 8. Workmanship, Finish, and Appearance

**8.1** The material shall be uniform in quality and temper, smooth, commercially straight or flat, and free of injurious imperfections.

## 9. Sampling

**9.1 Lot — Definition:**

**9.1.1** A lot for chemical analysis shall consist of one heat.

**9.1.2** A lot for mechanical testing shall consist of all material from the same heat, nominal thickness, and condition.

**9.1.2.1** Where material cannot be identified by heat, a lot shall consist of not more than 500 lb (227 kg)

of material in the same thickness and condition, except for plates weighing over 500 lb (227 kg), in which case only one specimen shall be taken.

### 9.2 Test Material Selection:

**9.2.1 Chemical Analysis**— Representative samples from each lot shall be taken during pouring or subsequent processing.

**9.2.1.1** Product (check) analysis shall be wholly the responsibility of the purchaser.

**9.2.2 Mechanical Properties** — Samples of the material to provide test specimens for mechanical properties shall be taken from such locations in each lot as to be representative of that lot.

## 10. Number of Tests

**10.1 Chemical Analysis** — One test per lot.

**10.2 Mechanical Properties** — One test per lot.

## 11. Specimen Preparation

**11.1** Tension test specimens shall be taken from material in the final condition (temper) and tested transverse to the direction of rolling when width will permit.

**11.2** Tension test specimens shall be any of the standard or subsize specimens shown in Test Methods E 8.

TABLE 4  
PERMISSIBLE VARIATIONS IN THICKNESS AND OVERWEIGHT OF RECTANGULAR PLATES

Specified Thickness, in. (mm)	Permissible Excess in Average Weight, <sup>B,C</sup> per Square Foot of Plates for Widths Given in Inches (Millimeters) Expressed in Percent of Nominal Weights										
	Under 48 (1220)	48 to 60 (1220 to 1520), excl	60 to 72 (1520 to 1830), excl	72 to 84 (1830 to 2130), excl	84 to 96 (2130 to 2440), excl	96 to 108 (2440 to 2740), excl	108 to 120 (2740 to 3050), excl	120 to 132 (3050 to 3350), excl	132 to 144 (3350 to 3660), excl	144 to 160 (3660 to 4070), excl	...
<sup>3</sup> / <sub>16</sub> to <sup>5</sup> / <sub>16</sub> (4.8 to 7.9), excl	9.0	10.5	12.0	13.5	15.0	16.5	18.0	...	...	...	...
<sup>5</sup> / <sub>16</sub> to <sup>3</sup> / <sub>8</sub> (7.9 to 9.5), excl	7.5	9.0	10.5	12.0	13.5	15.0	16.5	18.0	...	...	...
<sup>3</sup> / <sub>8</sub> to <sup>7</sup> / <sub>16</sub> (9.5 to 11.1), excl	7.0	7.5	9.0	10.5	12.0	13.5	15.0	16.5	18.0	...	...
<sup>7</sup> / <sub>16</sub> to <sup>1</sup> / <sub>2</sub> (11.1 to 12.7), excl	6.0	7.0	7.5	9.0	10.5	12.0	13.5	15.0	16.5	18.0	...
<sup>1</sup> / <sub>2</sub> to <sup>5</sup> / <sub>8</sub> (12.7 to 15.9), excl	5.0	6.0	7.0	7.5	9.0	10.5	12.0	13.5	15.0	16.5	...
<sup>5</sup> / <sub>8</sub> to <sup>3</sup> / <sub>4</sub> (15.9 to 19.1), excl	4.5	5.5	6.0	7.0	7.5	9.0	10.5	12.0	13.5	15.0	...
<sup>3</sup> / <sub>4</sub> to 1 (19.1 to 25.4), excl	4.0	4.5	5.5	6.0	7.0	7.5	9.0	10.5	12.0	13.5	...
1 to 2 (25.4 to 50.8), incl	4.0	4.0	4.5	5.5	6.0	7.0	7.5	9.0	10.5	12.0	...

NOTE 1 — All plates shall be ordered to thickness and not to weight per square foot. No plates shall vary more than 0.01 in. (0.3 mm) under the thickness ordered, and the overweight of each lot<sup>A</sup> in each shipment shall not exceed the amount given in the table. Spot grinding is permitted to remove surface imperfections, such spots not to exceed 0.01 in. (0.3 mm) under the specified thickness.

<sup>A</sup> The term "lot" applied to this table means all of the plates of each group width and each group thickness.

<sup>B</sup> The permissible overweight for lots of circular and sketch plates shall be 25% greater than the amounts given in this table.

<sup>C</sup> The weight of individual plates shall not exceed the nominal weight by more than 1/4 times the amount given in the table and Footnote B.

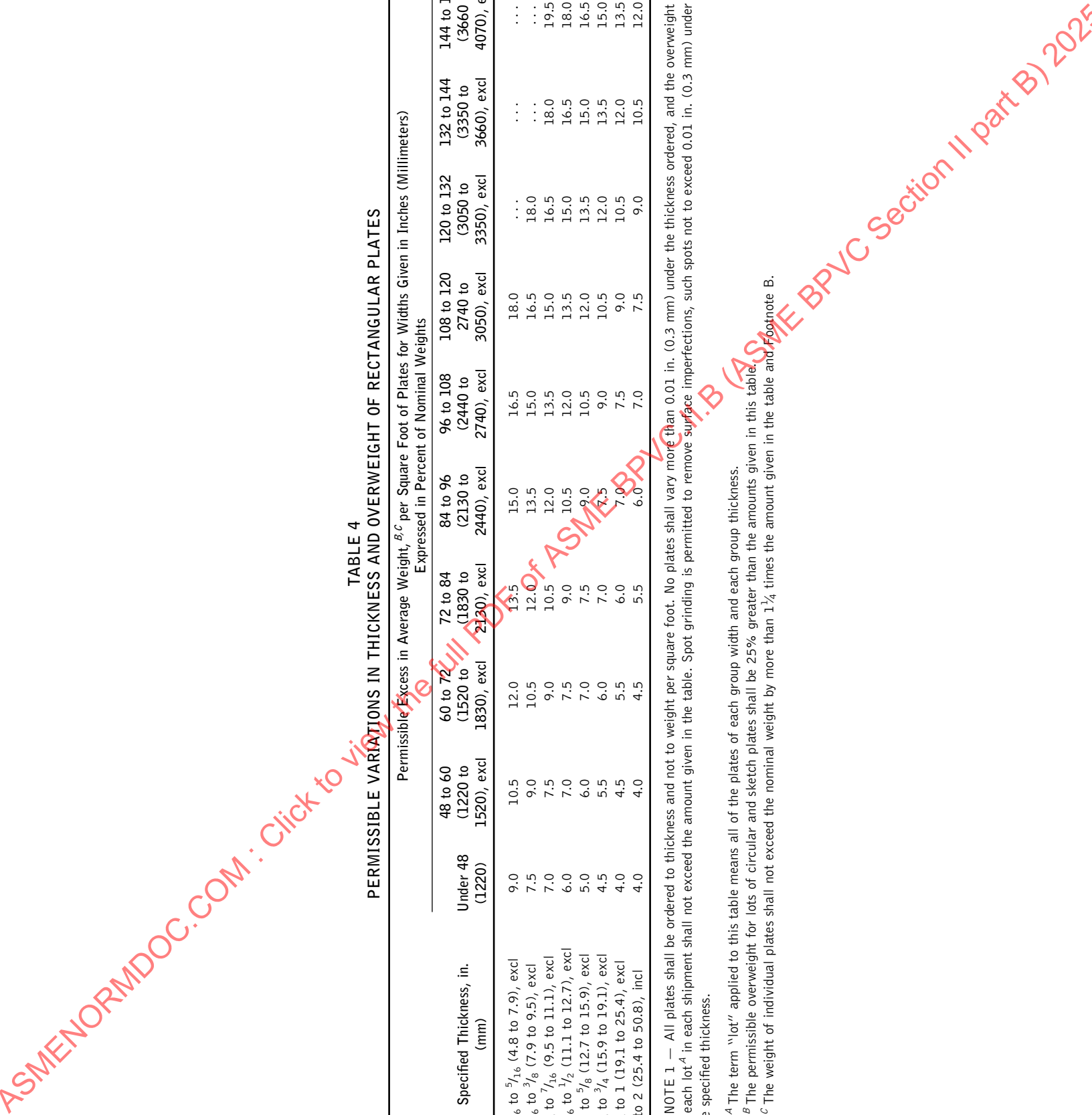

**TABLE 5**  
**PERMISSIBLE VARIATIONS IN THICKNESS FOR RECTANGULAR PLATES OVER 2 in. (51 mm) IN THICKNESS**

Specified Thickness, in. (mm)	Permissible Variations, in. (mm), Over Specified Thickness for Widths Given, in. (mm)					
	To 36 (915), excl	36 to 60 (915 to 1520), excl	60 to 84 (1520 to 2130), excl	84 to 120 (2130 to 3050), excl	120 to 132 (3050 to 3350), excl	132 (3350 and over)
Over 2 to 2 <sup>3</sup> / <sub>4</sub> (51 to 69.8), incl	<sup>1</sup> / <sub>16</sub> (1.6)	<sup>3</sup> / <sub>32</sub> (2.4)	<sup>7</sup> / <sub>64</sub> (2.8)	<sup>1</sup> / <sub>8</sub> (3.2)	<sup>1</sup> / <sub>8</sub> (3.2)	<sup>9</sup> / <sub>64</sub> (3.6)

NOTE 1 — Permissible variation under specified thickness, 0.01 in. (0.3 mm).

**TABLE 6**  
**PERMISSIBLE VARIATIONS IN THICKNESS OF SHEET AND STRIP**  
**[Permissible Variations, Plus and Minus, in Thickness, in. (mm), for Widths Given in in. (mm)]**

Specified Thickness, in. (mm), incl	Sheet <sup>A</sup>			
	Hot-Rolled		Cold-Rolled	
	48 (1220) and Under	Over 48 to 60 (1220 to 1520), incl	48 (1220) and Under	Over 48 to 60 (1220 to 1520), incl
0.018 to 0.025 (0.5 to 0.6)	0.003 (0.08)	0.004 (0.10)	0.002 (0.05)	0.003 (0.08)
Over 0.025 to 0.034 (0.6 to 0.9)	0.004 (0.10)	0.005 (0.13)	0.003 (0.08)	0.004 (0.10)
Over 0.034 to 0.043 (0.9 to 1.1)	0.005 (0.13)	0.006 (0.15)	0.004 (0.10)	0.005 (0.13)
Over 0.043 to 0.056 (1.1 to 1.4)	0.005 (0.13)	0.006 (0.15)	0.004 (0.10)	0.005 (0.13)
Over 0.056 to 0.070 (1.4 to 1.8)	0.006 (0.15)	0.007 (0.18)	0.005 (0.13)	0.006 (0.15)
Over 0.070 to 0.078 (1.8 to 1.9)	0.007 (0.18)	0.008 (0.20)	0.006 (0.15)	0.007 (0.18)
Over 0.078 to 0.093 (1.9 to 2.4)	0.008 (0.20)	0.009 (0.23)	0.007 (0.18)	0.008 (0.20)
Over 0.093 to 0.109 (2.4 to 2.8)	0.009 (0.23)	0.010 (0.25)	0.007 (0.18)	0.009 (0.23)
Over 0.109 to 0.125 (2.8 to 3.2)	0.010 (0.25)	0.012 (0.31)	0.008 (0.20)	0.010 (0.25)
Over 0.125 to 0.140 (3.2 to 3.6)	0.012 (0.31)	0.014 (0.36)	0.008 (0.20)	0.010 (0.25)
Over 0.140 to 0.171 (3.6 to 4.3)	0.014 (0.36)	0.016 (0.41)	0.009 (0.23)	0.012 (0.31)
Over 0.171 to 0.187 (4.3 to 4.8)	0.015 (0.38)	0.017 (0.43)	0.010 (0.25)	0.013 (0.33)
Over 0.187 to 0.218 (4.8 to 5.5)	0.017 (0.43)	0.019 (0.48)	0.011 (0.28)	0.015 (0.38)
Over 0.218 to 0.234 (5.5 to 5.9)	0.018 (0.46)	0.020 (0.51)	0.012 (0.31)	0.016 (0.41)
Over 0.234 to 0.250 (5.9 to 6.4)	0.020 (0.51)	0.022 (0.56)	0.013 (0.33)	0.018 (0.46)

Specified Thickness, in. (mm), incl	Cold-Rolled <sup>A,B</sup>
	Widths 12 in. (305 mm) and under, plus and minus
Up to 0.050 (1.27), incl	0.0015 (0.038)
Over 0.050 to 0.093 (1.27 to 2.39)	0.0025 (0.063)
Over 0.093 to 0.125 (2.39 to 3.18)	0.004 (0.11)

<sup>A</sup> Measured <sup>3</sup>/<sub>8</sub> in. (9.5 mm) or more from either edge except for strip under 1 in. (25.4 mm) in width which is measured at any place.

<sup>B</sup> Standard sheet tolerances apply for thicknesses over 0.125 in. (3.2 mm) and for all thicknesses of strip over 12 in. (305 mm) wide.

TABLE 7  
PERMISSIBLE VARIATIONS IN WIDTH<sup>A</sup> OF SHEARED, PLASMA TORCH-CUT, AND ABRASIVE-CUT RECTANGULAR PLATE<sup>B,C</sup>

Specified Thickness	Permissible Variations in Widths for Widths Given, in. (mm)									
	Up to 30 (760), incl		Over 30 to 72 (760 to 1830), incl		Over 72 to 108 (1830 to 2740), incl		Over 108 to 144 (2740 to 3660), incl		Over 144 to 160 (3660 to 4070), incl	
	Plus	Minus	Plus	Minus	Plus	Minus	Plus	Minus	Plus	Minus
Inches										
Sheared: <sup>D</sup>										
<sup>3</sup> / <sub>16</sub> to <sup>5</sup> / <sub>16</sub> , excl	<sup>3</sup> / <sub>16</sub>	<sup>1</sup> / <sub>8</sub>	<sup>1</sup> / <sub>4</sub>	<sup>1</sup> / <sub>8</sub>	<sup>3</sup> / <sub>8</sub>	<sup>1</sup> / <sub>8</sub>	<sup>1</sup> / <sub>2</sub>	<sup>1</sup> / <sub>8</sub>	...	...
<sup>5</sup> / <sub>16</sub> to <sup>1</sup> / <sub>2</sub> , excl	<sup>1</sup> / <sub>4</sub>	<sup>1</sup> / <sub>8</sub>	<sup>3</sup> / <sub>8</sub>	<sup>1</sup> / <sub>8</sub>	<sup>3</sup> / <sub>8</sub>	<sup>1</sup> / <sub>8</sub>	<sup>1</sup> / <sub>2</sub>	<sup>1</sup> / <sub>8</sub>	<sup>5</sup> / <sub>8</sub>	<sup>1</sup> / <sub>8</sub>
<sup>1</sup> / <sub>2</sub> to <sup>3</sup> / <sub>4</sub> , incl	<sup>3</sup> / <sub>8</sub>	<sup>1</sup> / <sub>8</sub>	<sup>3</sup> / <sub>8</sub>	<sup>1</sup> / <sub>8</sub>	<sup>1</sup> / <sub>2</sub>	<sup>1</sup> / <sub>8</sub>	<sup>5</sup> / <sub>8</sub>	<sup>1</sup> / <sub>8</sub>	<sup>3</sup> / <sub>4</sub>	<sup>1</sup> / <sub>8</sub>
<sup>3</sup> / <sub>4</sub> to 1, incl	<sup>1</sup> / <sub>2</sub>	<sup>1</sup> / <sub>8</sub>	<sup>1</sup> / <sub>2</sub>	<sup>1</sup> / <sub>8</sub>	<sup>5</sup> / <sub>8</sub>	<sup>1</sup> / <sub>8</sub>	<sup>3</sup> / <sub>4</sub>	<sup>1</sup> / <sub>8</sub>	<sup>7</sup> / <sub>8</sub>	<sup>1</sup> / <sub>8</sub>
1 to 1 <sup>1</sup> / <sub>4</sub> , incl	<sup>5</sup> / <sub>8</sub>	<sup>1</sup> / <sub>8</sub>	<sup>5</sup> / <sub>8</sub>	<sup>1</sup> / <sub>8</sub>	<sup>3</sup> / <sub>4</sub>	<sup>1</sup> / <sub>8</sub>	<sup>7</sup> / <sub>8</sub>	<sup>1</sup> / <sub>8</sub>	1	<sup>1</sup> / <sub>8</sub>
Abrasive-cut: <sup>E,F</sup>										
<sup>3</sup> / <sub>16</sub> to 1 <sup>1</sup> / <sub>4</sub> , incl	<sup>1</sup> / <sub>8</sub>	<sup>1</sup> / <sub>8</sub>	<sup>1</sup> / <sub>8</sub>	<sup>1</sup> / <sub>8</sub>	<sup>1</sup> / <sub>8</sub>	<sup>1</sup> / <sub>8</sub>	<sup>1</sup> / <sub>8</sub>	<sup>1</sup> / <sub>8</sub>	<sup>1</sup> / <sub>8</sub>	<sup>1</sup> / <sub>8</sub>
Over 1 <sup>1</sup> / <sub>4</sub> to 2 <sup>3</sup> / <sub>4</sub> , incl	<sup>3</sup> / <sub>16</sub>	<sup>1</sup> / <sub>8</sub>	<sup>3</sup> / <sub>16</sub>	<sup>1</sup> / <sub>8</sub>	<sup>3</sup> / <sub>16</sub>	<sup>1</sup> / <sub>8</sub>	<sup>3</sup> / <sub>16</sub>	<sup>1</sup> / <sub>8</sub>	<sup>3</sup> / <sub>16</sub>	<sup>1</sup> / <sub>8</sub>
Plasma torch-cut: <sup>G</sup>										
<sup>3</sup> / <sub>16</sub> to 2, excl	<sup>1</sup> / <sub>2</sub>	0	<sup>1</sup> / <sub>2</sub>	0	<sup>1</sup> / <sub>2</sub>	0	<sup>1</sup> / <sub>2</sub>	0	<sup>1</sup> / <sub>2</sub>	0
2 to 2 <sup>3</sup> / <sub>4</sub> , incl	<sup>5</sup> / <sub>8</sub>	0	<sup>5</sup> / <sub>8</sub>	0	<sup>5</sup> / <sub>8</sub>	0	<sup>5</sup> / <sub>8</sub>	0	<sup>5</sup> / <sub>8</sub>	0
Millimeters										
Sheared: <sup>D</sup>										
4.8 to 7.9, excl	4.8	3.2	6.4	3.2	9.5	3.2	12.7	3.2	...	...
7.9 to 12.7, excl	6.4	3.2	9.5	3.2	9.5	3.2	12.7	3.2	15.9	3.2
12.7 to 19.1, excl	9.5	3.2	9.5	3.2	12.7	3.2	15.9	3.2	19.1	3.2
19.1 to 25.4, excl	12.7	3.2	12.7	3.2	15.8	3.2	19.1	3.2	22.2	3.2
25.4 to 31.8, incl	15.9	3.2	15.9	3.2	19.1	3.2	22.2	3.2	25.4	3.2
Abrasive-cut: <sup>E,F</sup>										
4.8 to 31.8, incl	3.2	3.2	3.2	3.2	3.2	3.2	3.2	3.2	3.2	3.2
Over 31.8 to 69.8, incl	4.8	3.2	4.8	3.2	4.8	3.2	4.8	3.2	4.8	3.2
Plasma torch-cut: <sup>G</sup>										
4.8 to 50.8, excl	12.7	0	12.7	0	12.7	0	12.7	0	12.7	0
50.8 to 69.8, incl	15.9	0	15.9	0	15.9	0	15.9	0	15.9	0

<sup>A</sup> Permissible variations in width for powder- or inert arc-cut plate shall be as agreed upon between the manufacturer and the purchaser.

<sup>B</sup> Permissible variations in machined, powder-, or inert arc-cut circular plate shall be as agreed upon between the manufacturer and the purchaser.

<sup>C</sup> Permissible variations in plasma torch-cut sketch plates shall be as agreed upon between the manufacturer and the purchaser.

<sup>D</sup> The minimum sheared width is 24 in. (610 mm).

<sup>E</sup> The minimum abrasive-cut width is 2 in. (50.8 mm) and increases to 4 in. (101.6 mm) for thicker plates.

<sup>F</sup> These tolerances are applicable to lengths of 240 in. (6100 mm), max. For lengths over 240 in. an additional <sup>1</sup>/<sub>16</sub> in. (1.6 mm) is permitted, both plus and minus.

<sup>G</sup> The tolerance spread shown for plasma torch cutting may be obtained all on the minus side, or divided between the plus and minus side if so specified by the purchaser.

TABLE 8  
PERMISSIBLE VARIATIONS IN DIAMETER FOR CIRCULAR PLATES

Sheared Plate					
Permissible Variations Over Specified Diameter for Thickness Given, in. (mm) <sup>A</sup>					
Specified Diameter, in. (mm)	To <sup>3</sup> / <sub>8</sub> (9.5), incl				
20 to 32 (508 to 813), excl	<sup>1</sup> / <sub>4</sub> (6.4)				
32 to 84 (813 to 2130), excl	<sup>5</sup> / <sub>16</sub> (7.9)				
84 to 108 (2130 to 2740), excl	<sup>3</sup> / <sub>8</sub> (9.5)				
108 to 140 (2740 to 3580), incl	<sup>7</sup> / <sub>16</sub> (11.1)				

Plasma Torch-Cut Plate <sup>B</sup>					
Permissible Variations in Specified Diameter for Thickness Given, in. (mm) <sup>C</sup>					
Specified Diameter, in. (mm)	Thickness, max, in. (mm)	<sup>3</sup> / <sub>16</sub> to 2 (4.8 to 50.8), excl		2 to 2 <sup>3</sup> / <sub>4</sub> (50.8 to 69.8), incl	
		Plus	Minus	Plus	Minus
19 to 20 (483 to 508), excl	2 <sup>3</sup> / <sub>4</sub> (69.8)	<sup>1</sup> / <sub>2</sub> (12.7)	0	<sup>5</sup> / <sub>8</sub> (15.9)	0
20 to 22 (508 to 559), excl	2 <sup>3</sup> / <sub>4</sub> (69.8)	<sup>1</sup> / <sub>2</sub> (12.7)	0	<sup>5</sup> / <sub>8</sub> (15.9)	0
22 to 24 (559 to 610), excl	2 <sup>1</sup> / <sub>2</sub> (63.5)	<sup>1</sup> / <sub>2</sub> (12.7)	0	<sup>5</sup> / <sub>8</sub> (15.9)	0
24 to 28 (610 to 711), excl	2 <sup>1</sup> / <sub>4</sub> (57.3)	<sup>1</sup> / <sub>2</sub> (12.7)	0	<sup>5</sup> / <sub>8</sub> (15.9)	0
28 to 32 (711 to 812), excl	2 (50.8)	<sup>1</sup> / <sub>2</sub> (12.7)	0	<sup>5</sup> / <sub>8</sub> (15.9)	0
32 to 34 (812 to 864), excl	1 <sup>3</sup> / <sub>4</sub> (44.5)	<sup>1</sup> / <sub>2</sub> (12.7)	0	...	...
34 to 38 (864 to 965), excl	1 <sup>1</sup> / <sub>2</sub> (38.1)	<sup>1</sup> / <sub>2</sub> (12.7)	0	...	...
38 to 40 (965 to 1020), excl	1 <sup>1</sup> / <sub>4</sub> (31.8)	<sup>1</sup> / <sub>2</sub> (12.7)	0	...	...
40 to 140 (1020 to 3560), incl	2 <sup>3</sup> / <sub>4</sub> (69.8)	<sup>1</sup> / <sub>2</sub> (12.7)	0	<sup>5</sup> / <sub>8</sub> (15.9)	0

<sup>A</sup> No permissible variations under.

<sup>B</sup> Permissible variations in plasma torch-cut sketch plates shall be as agreed upon between the manufacturer and the purchaser.

<sup>C</sup> The tolerance spread shown may also be obtained all on the minus side or divided between the plus and minus sides if so specified by the purchaser.

TABLE 9  
PERMISSIBLE VARIATIONS IN WIDTH OF SHEET AND STRIP

Specified Thickness, in. (mm)	Specified Width, in. (mm)	Permissible Variations in Specified Width, in. (mm)	
		Plus	Minus
Sheet			
Up to 0.250 (6.35)	All	0.125 (3.18)	0
Strip			
Under 0.075 (1.9)	Up to 12 (305), incl	0.007 (0.18)	0.007 (0.18)
	Over 12 to 48 (305 to 1219), incl	0.062 (1.6)	0
0.075 to 0.100 (1.9 to 2.5), incl	Up to 12 (305), incl	0.009 (0.23)	0.009 (0.23)
	Over 12 to 48 (305 to 1219), incl	0.062 (1.6)	0
Over 0.100 to 0.125 (2.5 to 3.2), incl	Up to 12 (305), incl	0.012 (0.30)	0.012 (0.30)
	Over 12 to 48 (305 to 1219), incl	0.062 (1.6)	0
Over 0.125 to 0.160 (3.2 to 4.1), incl	Up to 12 (305), incl	0.016 (0.41)	0.016 (0.41)
	Over 12 to 48 (305 to 1219), incl	0.062 (1.6)	0
Over 0.160 to 0.187 (4.1 to 4.7), incl	Up to 12 (305), incl	0.020 (0.51)	0.020 (0.51)
	Over 12 to 48 (305 to 1219), incl	0.062 (1.6)	0
Over 0.187 to 0.250 (4.7 to 6.4), incl	Up to 12 (305), incl	0.062 (1.6)	0.062 (1.6)
	Over 12 to 48 (305 to 1219), incl	0.062 (1.6)	0.062 (1.6)

**11.3** In the event of disagreement, referee specimens shall be as follows:

**11.3.1** Full thickness of the material, machined to the form and dimensions shown for the sheet-type specimen in Test Methods E 8 for material under  $\frac{1}{2}$  in. (12.7 mm) in thickness.

**11.3.2** The largest possible round specimen shown in Test Methods E 8 for material  $\frac{1}{2}$  in. (12.7 mm) and over.

## 12. Test Methods

**12.1** The chemical composition and mechanical and other properties of the material as enumerated in this specification shall be determined, in case of disagreement, in accordance with the following ASTM standards:

Test	ASTM Designation
Chemical analysis	E 1473
Tension	E 8
Rounding procedure	E 29

**12.2** For purposes of determining compliance with the specified limits for requirements of the properties listed in the following table, an observed or calculated value shall be rounded in accordance with the rounding method of Practice E 29.

Test	Rounded Unit for Observed or Calculated Value
Chemical composition and tolerances (when expressed in decimals)	Nearest unit in the last right-hand-place of figures of the specified limit. If two choices are possible, as when the digits dropped are exactly a 5, or a 5 followed only by zeros, choose the one ending in an even digit, with zero defined as an even digit.
Tensile strength and yield strength	Nearest 1000 psi (6.9 MPa)
Elongation	Nearest 1%

## 13. Inspection

**13.1** Inspection of the material shall be made as agreed upon between the manufacturer and the purchaser as part of the purchase contract.

## 14. Rejection and Rehearing

**14.1** Material tested by the purchaser that fails to conform to the requirements of this specification may be rejected. Rejection should be reported to the producer or supplier promptly and in writing. In case of dissatisfaction with the results of the test, the producer or supplier may make claim for a rehearing.

TABLE 10  
 PERMISSIBLE VARIATIONS IN LENGTH<sup>A</sup> OF SHEARED, PLASMA TORCH-CUT,<sup>B</sup> AND ABRASIVE-CUT  
 RECTANGULAR PLATE<sup>C</sup>

Specified Thickness	Permissible Variation in Length for Lengths Given, in. (mm)															
	Up to 60 (1520), incl		Over 60 to 96 (1520 to 2440), incl		Over 96 to 120 (2440 to 3050), incl		Over 120 to 240 (3050 to 6096), incl		Over 240 to 360 (6096 to 9144), incl		Over 360 to 450 (9144 to 11 430), incl		Over 450 to 540 (11 430 to 13 716), incl		Over 540 (13 716)	
	Plus	Minus	Plus	Minus	Plus	Minus	Plus	Minus	Plus	Minus	Plus	Minus	Plus	Minus	Plus	Minus
Inches																
Sheared: <sup>D</sup>																
<sup>3</sup> / <sub>16</sub> to <sup>5</sup> / <sub>16</sub> , excl	<sup>3</sup> / <sub>16</sub>	<sup>1</sup> / <sub>8</sub>	<sup>1</sup> / <sub>4</sub>	<sup>1</sup> / <sub>8</sub>	<sup>3</sup> / <sub>8</sub>	<sup>1</sup> / <sub>8</sub>	<sup>1</sup> / <sub>2</sub>	<sup>1</sup> / <sub>8</sub>	<sup>5</sup> / <sub>8</sub>	<sup>1</sup> / <sub>8</sub>	<sup>3</sup> / <sub>4</sub>	<sup>1</sup> / <sub>8</sub>	<sup>7</sup> / <sub>8</sub>	<sup>1</sup> / <sub>8</sub>	...	...
<sup>5</sup> / <sub>16</sub> to <sup>1</sup> / <sub>2</sub> , excl	<sup>3</sup> / <sub>8</sub>	<sup>1</sup> / <sub>8</sub>	<sup>1</sup> / <sub>2</sub>	<sup>1</sup> / <sub>8</sub>	<sup>1</sup> / <sub>2</sub>	<sup>1</sup> / <sub>8</sub>	<sup>1</sup> / <sub>2</sub>	<sup>1</sup> / <sub>8</sub>	<sup>5</sup> / <sub>8</sub>	<sup>1</sup> / <sub>8</sub>	<sup>3</sup> / <sub>4</sub>	<sup>1</sup> / <sub>8</sub>	<sup>7</sup> / <sub>8</sub>	<sup>1</sup> / <sub>8</sub>	1	<sup>1</sup> / <sub>8</sub>
<sup>1</sup> / <sub>2</sub> to <sup>3</sup> / <sub>4</sub> , excl	<sup>1</sup> / <sub>2</sub>	<sup>1</sup> / <sub>8</sub>	<sup>1</sup> / <sub>2</sub>	<sup>1</sup> / <sub>8</sub>	<sup>5</sup> / <sub>8</sub>	<sup>1</sup> / <sub>8</sub>	<sup>5</sup> / <sub>8</sub>	<sup>1</sup> / <sub>8</sub>	<sup>1</sup> / <sub>8</sub>	<sup>1</sup> / <sub>8</sub>	<sup>7</sup> / <sub>8</sub>	<sup>1</sup> / <sub>8</sub>	<sup>1</sup> / <sub>2</sub>	<sup>1</sup> / <sub>8</sub>	<sup>1</sup> / <sub>2</sub>	<sup>1</sup> / <sub>8</sub>
<sup>3</sup> / <sub>4</sub> to 1, excl	<sup>5</sup> / <sub>8</sub>	<sup>1</sup> / <sub>8</sub>	<sup>5</sup> / <sub>8</sub>	<sup>1</sup> / <sub>8</sub>	<sup>5</sup> / <sub>8</sub>	<sup>1</sup> / <sub>8</sub>	<sup>3</sup> / <sub>4</sub>	<sup>1</sup> / <sub>8</sub>	<sup>7</sup> / <sub>8</sub>	<sup>1</sup> / <sub>8</sub>	<sup>1</sup> / <sub>2</sub>	<sup>1</sup> / <sub>8</sub>	<sup>1</sup> / <sub>2</sub>	<sup>1</sup> / <sub>8</sub>	<sup>1</sup> / <sub>2</sub>	<sup>1</sup> / <sub>8</sub>
1 to 1 <sup>1</sup> / <sub>4</sub> , incl	<sup>3</sup> / <sub>4</sub>	<sup>1</sup> / <sub>8</sub>	<sup>3</sup> / <sub>4</sub>	<sup>1</sup> / <sub>8</sub>	<sup>3</sup> / <sub>4</sub>	<sup>1</sup> / <sub>8</sub>	<sup>7</sup> / <sub>8</sub>	<sup>1</sup> / <sub>8</sub>	<sup>1</sup> / <sub>2</sub>	<sup>1</sup> / <sub>8</sub>	<sup>1</sup> / <sub>2</sub>	<sup>1</sup> / <sub>8</sub>	<sup>1</sup> / <sub>2</sub>	<sup>1</sup> / <sub>8</sub>	...	...
Abrasive-cut: <sup>E</sup>																
<sup>3</sup> / <sub>16</sub> to 1 <sup>1</sup> / <sub>4</sub> , incl	<sup>1</sup> / <sub>8</sub>	<sup>1</sup> / <sub>8</sub>	<sup>1</sup> / <sub>8</sub>	<sup>1</sup> / <sub>8</sub>	<sup>1</sup> / <sub>8</sub>	<sup>1</sup> / <sub>8</sub>	<sup>1</sup> / <sub>8</sub>	<sup>1</sup> / <sub>8</sub>	<sup>1</sup> / <sub>8</sub>	<sup>1</sup> / <sub>8</sub>	<sup>1</sup> / <sub>8</sub>	<sup>1</sup> / <sub>8</sub>	<sup>1</sup> / <sub>8</sub>	...	...	...
Over 1 <sup>1</sup> / <sub>4</sub> to 2 <sup>3</sup> / <sub>4</sub> , incl	<sup>3</sup> / <sub>16</sub>	<sup>1</sup> / <sub>8</sub>	<sup>3</sup> / <sub>16</sub>	<sup>1</sup> / <sub>8</sub>	<sup>3</sup> / <sub>16</sub>	<sup>1</sup> / <sub>8</sub>	<sup>3</sup> / <sub>16</sub>	<sup>1</sup> / <sub>8</sub>	<sup>3</sup> / <sub>16</sub>	<sup>1</sup> / <sub>8</sub>	<sup>3</sup> / <sub>16</sub>	<sup>1</sup> / <sub>8</sub>	<sup>3</sup> / <sub>16</sub>	<sup>1</sup> / <sub>8</sub>	...	...
Plasma torch-cut: <sup>F</sup>																
<sup>3</sup> / <sub>16</sub> to 2, excl	<sup>1</sup> / <sub>2</sub>	0	<sup>1</sup> / <sub>2</sub>	0	<sup>1</sup> / <sub>2</sub>	0	<sup>1</sup> / <sub>2</sub>	0	<sup>1</sup> / <sub>2</sub>	0	<sup>1</sup> / <sub>2</sub>	0	<sup>1</sup> / <sub>2</sub>	0	<sup>1</sup> / <sub>2</sub>	0
2 to 2 <sup>3</sup> / <sub>4</sub>	<sup>5</sup> / <sub>8</sub>	0	<sup>5</sup> / <sub>8</sub>	0	<sup>5</sup> / <sub>8</sub>	0	<sup>5</sup> / <sub>8</sub>	0	<sup>5</sup> / <sub>8</sub>	0	<sup>5</sup> / <sub>8</sub>	0	<sup>5</sup> / <sub>8</sub>	0	<sup>5</sup> / <sub>8</sub>	0
Millimeters																
Sheared: <sup>D</sup>																
4.8 to 7.94, excl	4.8	3.2	6.4	3.2	9.5	3.2	12.7	3.2	15.9	3.2	19.0	3.2	22.2	3.2	...	...
7.94 to 12.7, excl	9.5	3.2	12.7	3.2	12.7	3.2	12.7	3.2	15.9	3.2	19.0	3.2	22.2	3.2	25.4	3.2
12.7 to 19.0, excl	12.7	3.2	12.7	3.2	15.9	3.2	15.9	3.2	19.0	3.2	22.2	3.2	28.6	3.2	34.9	3.2
19.0 to 25.4, excl	15.9	3.2	15.9	3.2	15.9	3.2	19.0	3.2	22.2	3.2	28.6	3.2	34.9	3.2	41.2	3.2
25.4 to 31.8, incl	19.0	3.2	19.0	3.2	19.0	3.2	22.2	3.2	28.6	3.2	34.9	3.2	41.2	3.2	...	...
Abrasive-cut: <sup>E</sup>																
4.8 to 31.8, incl	3.2	3.2	3.2	3.2	3.2	3.2	3.2	3.2	3.2	3.2	3.2	3.2	3.2	...	...	...
Over 31.8 to 69.9, incl	4.8	3.2	4.8	3.2	4.8	3.2	4.8	3.2	4.8	3.2	4.8	3.2	4.8	3.2	...	...
Plasma torch-cut: <sup>F</sup>																
4.8 to 50.8, excl	12.7	0	12.7	0	12.7	0	12.7	0	12.7	0	12.7	0	12.7	0	12.7	0
50.8 to 69.8, incl	15.9	0	15.9	0	15.9	0	15.9	0	15.9	0	15.9	0	15.9	0	15.9	0

<sup>A</sup> Permissible variations in length for powder- or inert arc-cut plate shall be as agreed upon between the manufacturer and the purchaser.  
<sup>B</sup> The tolerance spread shown for plasma torch cutting may be obtained all on the minus side, or divided between the plus and minus sides if so specified by the purchaser.  
<sup>C</sup> Permissible variations in machined, powder-, or inert arc-cut circular plate shall be as agreed upon between the manufacturer and the purchaser.  
<sup>D</sup> The minimum sheared length is 24 in. (610 mm).  
<sup>E</sup> Abrasive cut applicable to a maximum length of 144 to 400 in. (3658 to 10 160 mm), depending on the thickness and width ordered.  
<sup>F</sup> The tolerance spread shown for plasma torch-cut sketch plates shall be as agreed upon between the manufacturer and the purchaser.

TABLE 11  
PERMISSIBLE VARIATIONS FROM FLATNESS OF RECTANGULAR, CIRCULAR, AND SKETCH PLATES

Specified Thickness	Permissible Variations from a Flat Surface for Thickness and Widths Given, in. (mm)								
	To 48 (1220), excl	48 to 60 (1220 to 1520), excl	60 to 72 (1520 to 1830), excl	72 to 84 (1830 to 2130), excl	84 to 96 (2130 to 2400), excl	96 to 108 (2440 to 2740), excl	108 to 120 (2740 to 3050), excl	120 to 144 (3050 to 3660), excl	144 (3660) and over
Inches									
$\frac{3}{16}$ to $\frac{1}{4}$ , excl	$1\frac{1}{2}$	$2\frac{1}{8}$	$2\frac{1}{2}$	$2\frac{3}{4}$	$3\frac{1}{4}$	$3\frac{1}{4}$	...	...	...
$\frac{1}{4}$ to $\frac{3}{8}$ , excl	$1\frac{3}{8}$	$1\frac{1}{2}$	$1\frac{7}{8}$	$2\frac{1}{4}$	$2\frac{3}{4}$	$2\frac{7}{8}$	$3\frac{1}{8}$	$3\frac{3}{4}$	...
$\frac{3}{8}$ to $\frac{1}{2}$ , excl	1	$1\frac{1}{8}$	$1\frac{3}{8}$	$1\frac{1}{2}$	$1\frac{7}{8}$	$2\frac{1}{4}$	$2\frac{1}{2}$	$2\frac{7}{8}$	$3\frac{1}{2}$
$\frac{1}{2}$ to $\frac{3}{4}$ , excl	1	$1\frac{1}{8}$	$1\frac{1}{4}$	$1\frac{1}{4}$	$1\frac{5}{8}$	$2\frac{1}{4}$	$2\frac{1}{4}$	$2\frac{1}{4}$	$2\frac{3}{4}$
$\frac{3}{4}$ to 1, excl	1	$1\frac{1}{8}$	$1\frac{1}{4}$	$1\frac{1}{4}$	$1\frac{1}{2}$	$1\frac{5}{8}$	$1\frac{7}{8}$	2	$2\frac{1}{4}$
1 to 2, excl	1	$1\frac{1}{8}$	$1\frac{1}{8}$	$1\frac{1}{8}$	$1\frac{3}{8}$	$1\frac{3}{8}$	$1\frac{3}{8}$	$1\frac{1}{2}$	2
2 to $2\frac{3}{4}$ , incl	$\frac{1}{2}$	$\frac{5}{8}$	$\frac{3}{4}$	$\frac{7}{8}$	1	$1\frac{1}{8}$	$1\frac{1}{4}$	$1\frac{1}{2}$	$1\frac{3}{4}$
Millimeters									
4.8 to 6.4, excl	38.1	54.0	63.5	69.8	82.6	82.6	...	...	...
6.4 to 9.5, excl	34.9	38.1	47.6	57.2	69.8	73.0	79.4	95.2	...
9.5 to 12.7, excl	25.4	28.6	34.9	38.1	47.6	57.2	63.5	73.0	88.9
12.7 to 19.0, excl	25.4	28.6	31.8	31.8	41.3	57.2	57.2	57.2	69.8
19.0 to 25.4, excl	25.4	28.6	31.8	31.8	38.1	41.3	47.6	50.8	57.2
25.4 to 50.8, excl	25.4	28.6	28.6	28.6	34.9	34.9	34.9	38.1	50.8
50.8 to 70.0, incl	12.7	15.9	19.0	22.2	25.4	28.6	31.8	38.1	44.4

NOTE 1 — Permissible variations apply to plates up to 12 ft (3.66 m) in length, or to any 12 ft (3.66 m) of longer plates.

NOTE 2 — If the longer dimension is under 36 in. (914 mm), the permissible variation is not greater than  $\frac{1}{2}$  in. (12.7) mm.

NOTE 3 — The shorter dimension specified is considered with width, and the permissible variation in flatness across the width does not exceed the tabular amount of that dimension.

NOTE 4 — The maximum deviation from a flat surface does not customarily exceed the tabular tolerance for the longer dimension specified.

## 15. Certification

**15.1** A manufacturer's certification shall be furnished to the purchaser stating that the material was manufactured, tested, and inspected in accordance with this specification, and that test results on representative samples meet specification requirements. A report of the test results shall be furnished.

## 16. Product Marking

**16.1** Each bundle or shipping container shall be marked with the name of the material or UNS number; condition

(temper); this specification number; the size; gross, tare, and net weight; consignor and consignee address; contract or order number; or such other information as may be defined in the contract or order.

## 17. Keywords

**17.1** UNS N06219; UNS N06625; plate; sheet; strip



**SPECIFICATION FOR NICKEL-CHROMIUM-  
MOLYBDENUM-COLUMBIUM ALLOYS (UNS N06625  
AND UNS N06852) AND NICKEL-CHROMIUM-  
MOLYBDENUM-SILICON ALLOY (UNS N06219) PIPE  
AND TUBE**



**SB-444**

(Identical with ASTM Specification B444-06(2011) except that certification and test report have been made mandatory per SB-829.)

# Standard Specification for Nickel-Chromium-Molybdenum-Columbium Alloys (UNS N06625 and UNS N06852) and Nickel-Chromium- Molybdenum-Silicon Alloy (UNS N06219) Pipe and Tube

## 1. Scope

1.1 This specification covers nickel-chromium-molybdenum-columbium alloys (UNS N06625 and UNS N06852) and nickel-chromium-molybdenum-silicon alloy (UNS N06219) in the form of cold-worked seamless pipe and tube. The general requirements for pipe and tube are covered by Specification B829.

1.1.1 UNS N06625 products are furnished in two grades of different heat-treated conditions:

1.1.1.1 *Grade 1 (annealed)*—Material is normally employed in service temperatures up to 1100°F (593°C).

1.1.1.2 *Grade 2 (solution annealed)*—Material is normally employed in service temperatures above 1100°F (593°C) when resistance to creep and rupture is required.

NOTE 1—Hot-working or reannealing may change properties significantly, depending on working history and temperatures.

1.1.2 Alloys UNS N06219 and UNS N06852 are supplied in the solution annealed condition only.

1.2 The values stated in inch-pound units are to be regarded as standard. The values given in parentheses are mathematical conversions to SI units that are provided for information only and are not considered standard.

1.3 The following precautionary caveat pertains only to the test methods portion, Section 9, of this specification: *This standard does not purport to address all of the safety concerns, if any, associated with its use. It is the responsibility of the user of this standard to become familiar with all hazards including those identified in the appropriate Material Safety Data Sheet (MSDS) for this product/material as provided by the*

*manufacturer, to establish appropriate safety and health practices, and determine the applicability of regulatory limitations prior to use.*

## 2. Referenced Documents

### 2.1 ASTM Standards:

B829 Specification for General Requirements for Nickel and Nickel Alloys Seamless Pipe and Tube

## 3. General Requirement

3.1 Material furnished under this specification shall conform to the applicable requirements of Specification B829 unless otherwise provided herein.

## 4. Ordering Information

4.1 Orders for material to this specification shall include information with respect to the following:

4.1.1 Alloy name or UNS number,

4.1.2 ASTM designation,

4.1.3 Condition (temper) (see 1.1.1, 1.1.2, Section 6, and Appendix X1 and Appendix X2),

4.1.3.1 If neither grade of N06625 is specified, Grade 1 will be supplied.

4.1.4 Finish (See Appendix X2),

4.1.5 *Dimensions:*

4.1.5.1 *Tube*—Specify outside diameter and nominal or minimum wall,

4.1.5.2 *Pipe*—Specify standard pipe size and schedule,

4.1.5.3 *Length*—Cut to length or random,

4.1.6 *Quantity*—Feet (or metres) or number of pieces,

4.1.7 *Hydrostatic Test or Nondestructive Electric Test*—Specify type of test (see 6.2),

4.1.8 *Hydrostatic Pressure Requirements*—Specify test pressure if other than required by 9.1.1,

4.1.9 DELETED

4.1.10 *Samples for Product (Check) Analysis*—State whether samples for product (check) analysis should be furnished (see 5.2),

4.1.11 *Purchaser Inspection*—If purchaser wishes to witness tests or inspection of material at place of manufacture, the purchase order must so state indicating which tests or inspections are to be witnessed, and

4.1.12 *Small-Diameter and Light-Wall Tube (Converter Sizes)*—See Appendix X1 and Table 1.

## 5. Chemical Composition

5.1 The material shall conform to the composition limits specified in Table 2. One test is required for each lot as defined in Specification B829.

5.2 If a product (check) analysis is performed by the purchaser, the material shall conform to the product (check) analysis variations in Table 2 of Specification B829.

## 6. Mechanical Properties and Other Requirements

6.1 *Tension Test*—The material shall conform to the tensile properties specified in Table 1. The sampling and specimen preparation are as covered in Specification B829.

6.2 *Hydrostatic or Nondestructive Electric Test*—Each pipe or tube shall be subjected to either the hydrostatic test or to the nondestructive electric test. The type of test to be used shall be at the option of the manufacturer, unless otherwise specified in the purchase order.

## 7. Dimensions and Permissible Variations

7.1 Permissible variations for material specified as small-diameter and light-wall tube (converter size) shall conform to the permissible variations prescribed in Table X1.1 and Table X1.2.

**TABLE 1 Room Temperature Tensile Properties and Heat Treatment Including Small Diameter and Light-Wall Tubing (Converter Sizes)<sup>AB</sup>**

Condition	Tensile Strength, min, ksi (MPa) <sup>C</sup>	Yield Strength (0.2% offset), min, ksi (MPa) <sup>C</sup>	Elongation in 2 in. or 50.8 mm (or 4 D), min, %
Alloy N06625			
Grade 1 (annealed) <sup>D</sup>	120 (827)	60 (414)	30
Grade 2 (solution annealed) <sup>E</sup>	100 (690)	40 (276)	30
Alloy N06219			
All (solution annealed)	96 (660)	39 (270)	30
Alloy N06852			
All (solution annealed)	85 (586)	35 (241)	30

<sup>A</sup> Not applicable to outside diameters under 1/8 in. (3.2 mm) and to wall thicknesses under 0.015 in. (0.38 mm).

<sup>B</sup> Hot forming quality pipe and tubing is furnished to chemical requirements and surface inspection only. No tensile properties are required.

<sup>C</sup> The minimum strength values apply only to tubing in straight lengths.

<sup>D</sup> Annealed at 1600°F (871°C) minimum.

<sup>E</sup> Solution annealed at 2000°F (1093°C) minimum, with or without subsequent stabilization anneal at 1800°F (982°C) minimum to increase resistance to sensitization.

**TABLE 2 Chemical Requirements**

Element	Composition Limits, %		
	N06852	N06625	N06219
Carbon	0.05 max	0.10 max	0.05 max
Manganese	0.50 max	0.50 max	0.50 max
Silicon	0.50 max	0.50 max	0.70-1.10
Phosphorus	0.015 max	0.015 max	0.020 max
Sulfur	0.015 max	0.015 max	0.010 max
Chromium	20.0-23.0	20.0 min	18.0-22.0
	...	23.0 max	...
Columbium + tantalum	...	3.15 min	...
	...	4.15 max	...
Columbium	0.51-1.00	...	...
Cobalt (if determined)	...	1.0 max	1.0 max
Molybdenum	8.0-10.0	8.0 min	7.0-9.0
	...	10.0 max	...
Iron	15.0-20.0	5.0 max	2.0-4.0
Aluminum	0.40 max	0.40 max	0.50 max
Titanium	0.40 max	0.40 max	0.50 max
Copper	...	...	0.50 max
Nickel <sup>A</sup>	Bal.	58.0 min	Bal.

<sup>A</sup> Element shall be determined arithmetically by difference.

## 8. Number of Tests

8.1 *Chemical Analysis*—One test per lot.

8.2 *Tension*—One test per lot.

8.3 *Hydrostatic or Nondestructive Electric Test*—Each piece in each lot.

## 9. Test Methods

9.1 *Hydrostatic Test*—Each pipe or tube with an outside diameter 1/8 in. (3 mm) and larger and with wall thickness of 0.015 in. (0.38 mm) and over shall be tested in accordance with Specification B829. The allowable fiber stress for material in the condition furnished, is as follows:

UNS N06625:

Grade 1—30 000 psi (207 MPa)

Grade 2—25 000 psi (172 MPa)

UNS N06219:

All—24 000 psi (165 MPa)

UNS N06852:

All—21 000 psi (145 MPa)

9.1.1 When so agreed upon by the manufacturer and purchaser, pipe or tube may be tested to 1/2 times the allowable fiber stress given above.

9.1.2 If any pipe or tube shows leak during hydrostatic testing, it shall be rejected.

9.2 *Nondestructive Electric Test*—Each pipe or tube shall be examined with a nondestructive electric test as per prescribed in Specification B829.

## 10. Keywords

10.1 seamless pipe; seamless tube; N06219; N06625

APPENDIXES

(Nonmandatory Information)

X1. CONVERTER SIZES

X1.1 Small-diameter and light-wall tube in outside diameters 1¼ in. (31.8 mm) and under may be furnished in a limited range of sizes and the manufacturer should be consulted as to

the various outside diameters and wall thicknesses that may be furnished. Material will have a bright finish. Such material shall conform to the requirements in Tables X1.1 and X1.2.

TABLE X1.1 Permissible Variations for Small-Diameter and Light-Wall Tube (Converter Sizes)<sup>A,B,C,D,E,F,G</sup>

Specified Outside Diameter, in. (mm)	Outside Diameter		Inside Diameter		Wall Thickness, %	
	Plus	Minus, in. (mm)	Plus	Minus	Plus	Minus
Under 3/32 (2.4)	0.002 (0.05)	0	0	0.002 (0.05)	10	10
3/32 to 3/16 (2.4 to 4.8), excl	0.003 (0.08)	0	0	0.003 (0.08)	10	10
3/16 to 1/2 (4.8 to 12.7), excl	0.004 (0.10)	0	0	0.004 (0.10)	10	10
1/2 to 1¼ (12.7 to 31.8), incl	0.005 (0.13)	0	0	0.005 (0.13)	10	10

<sup>A</sup> *Ovality, Normal-Wall Tube*—Ovality will be held within 2 % of the theoretical average outside diameter.

<sup>B</sup> *Ovality, Light-Wall Tube*—Ovality will be held within 3 % of the theoretical average outside diameter.

<sup>C</sup> *Wall Tolerances, Light-Wall Tube*—The plus and minus wall tolerance shown in the table shall apply down to and including 0.005 in. (0.13 mm) in wall thickness. For wall thicknesses less than 0.005 in. (0.13 mm), the tolerance shall be ±0.0005 in. (0.013 mm).

<sup>D</sup> *Random Lengths:*

Where nominal random lengths on tubing 1/8 in. (3.2 mm) and larger in outside diameter are specified, a length tolerance of ±3½ ft (1.07 m) applies to the nominal length. This is a total spread of 7 ft (2.13 m).

Random lengths in sizes 1/8 in. (3.2 mm) and larger in outside diameter shall be subject to a length range of 5 to 24 ft (1.52 to 7.32 m). Long random lengths are subject to a range from 15 to 22 ft (4.57 to 6.71 m).

Random lengths in sizes up to, but not including 1/8 in. (3.2 mm) in outside diameter, and fragile light-wall tubes over this outside diameter are subject to the length range from 1 to 15 ft (0.30 to 4.57 m).

<sup>E</sup> *Cut Lengths*—Tolerances on cut lengths shall be in accordance with Table X1.1.

<sup>F</sup> *Straightness*—Round tubing is subject to a straightness tolerance of 1 part in 600 [equivalent to a depth of arc of 0.030 in. (0.76 mm) in any 3 ft (0.91 m) of length].

<sup>G</sup> When specified, the tolerance spreads of this table may be applied as desired. However, when not specified, the tolerances in this table will apply. It should be noted that inside diameter tolerances are based upon the outside diameter range.

TABLE X1.2 Tolerances on Cut Lengths of Light-Wall Tube

Length, ft (m)	Tube Size, in. (mm)	Permissible Variations, in. (mm)	
		Over	Under
Under 1 (0.30)	up to 1.250 (31.8), incl	1/32 (0.8)	0 (0)
1 to 4 (0.30 to 1.22), incl	up to 1.250 (31.8), incl	1/16 (1.6)	0 (0)
Over 4 to 10 (1.22 to 3.0), incl	up to 1.250 (31.8), incl	3/32 (2.4)	0 (0)
Over 10 (3.0)	up to 1.250 (31.8), incl	3/16 (4.8)	0 (0)

X2. CONDITIONS AND FINISHES NORMALLY SUPPLIED

X2.1 Scope

X2.1.1 This appendix lists the conditions and finishes in which pipe and tube (other than converter sizes) are normally supplied. These are subject to change, and the manufacturer should be consulted for the latest information available.

X2.2 Cold-Worked Tube and Pipe

X2.2.1 *Cold-Drawn, Annealed or Solution Annealed with Ground Outside Diameter*—The inside diameter may have a bright finish when material is annealed or solution annealed in a protective atmosphere; otherwise, the inside diameter is

supplied descaled as necessary. It is available in sizes 1/2 to 4 in. (12.7 to 102 mm), incl, in outside diameter in both normal and heavy-wall tube, and pipe sizes, all schedules, of corresponding outside-diameter dimensions.

X2.2.2 *Cold-Drawn, Annealed or Solution Annealed and Pickled (Not Ground)*—Outside and inside diameter will have dull, matte (pickled) surfaces. Available in sizes 1/2 to 6½ in. (12.7 to 168 mm), incl, in outside diameter in both normal and heavy-wall tube, and pipe sizes, all schedules, of corresponding outside-diameter dimensions.

**SPECIFICATION FOR NICKEL-CHROMIUM-  
MOLYBDENUM-COLUMBIUM ALLOY (UNS N06625),  
NICKEL-CHROMIUM-MOLYBDENUM-SILICON ALLOY  
(UNS N06219), AND NICKEL-CHROMIUM-  
MOLYBDENUM-TUNGSTEN ALLOY (UNS N06650) ROD  
AND BAR**



**SB-446**

(Identical with ASTM Specification B446-19 except for the deletion of para. 9.1.2.1.)

# Specification for Nickel-Chromium-Molybdenum-Columbium Alloy (UNS N06625), Nickel-Chromium-Molybdenum-Silicon Alloy (UNS N06219), and Nickel-Chromium-Molybdenum-Tungsten Alloy (UNS N06650) Rod and Bar

## 1. Scope

1.1 This specification covers nickel-chromium-molybdenum-columbium (UNS N06625), nickel-chromium-molybdenum-silicon alloy (UNS N06219), and Nickel-Chromium-Molybdenum-Tungsten Alloy (UNS N06650) in the form of hot-worked rod and bar and cold-worked rod in the conditions shown in Table 1.

1.1.1 UNS N06625 products are furnished in two grades of different heat-treated conditions:

1.1.1.1 *Grade 1 (Annealed)*—Material is normally employed in service temperatures up to 1100°F (593°C).

1.1.1.2 *Grade 2 (Solution Annealed)*—Material is normally employed in service temperatures above 1100°F (593°C) when resistance to creep and rupture is required.

NOTE 1—Hot-working or reannealing may change properties significantly, depending on working history and temperatures.

1.1.2 Alloys UNS N06219 and UNS N06650 are supplied in solution annealed condition only.

1.2 The values stated in inch-pound units are to be regarded as standard. The values given in parentheses are mathematical conversions to SI units that are provided for information only and are not considered standard.

1.3 The following precautionary caveat pertains only to the test methods portion, Section 12, of this specification: *cThis standard does not purport to address all of the safety concerns, if any, associated with its use. It is the responsibility of the user of this standard to become familiar with all hazards including those identified in the appropriate Safety Data Sheet (SDS) for this product/material as provided by the manufacturer, to*

*establish appropriate safety, health, and environmental practices, and determine the applicability of regulatory limitations prior to use.*

1.4 *This international standard was developed in accordance with internationally recognized principles on standardization established in the Decision on Principles for the Development of International Standards, Guides and Recommendations issued by the World Trade Organization Technical Barriers to Trade (TBT) Committee.*

## 2. Referenced Documents

### 2.1 ASTM Standards:

B443 Specification for Nickel-Chromium-Molybdenum-Columbium Alloy (UNS N06625) and Nickel-Chromium-Molybdenum-Silicon Alloy (UNS N06219) Plate, Sheet, and Strip

B880 Specification for General Requirements for Chemical Check Analysis Limits for Nickel, Nickel Alloys and Cobalt Alloys

E8/E8M Test Methods for Tension Testing of Metallic Materials

E29 Practice for Using Significant Digits in Test Data to Determine Conformance with Specifications

E1473 Test Methods for Chemical Analysis of Nickel, Cobalt and High-Temperature Alloys

## 3. Terminology

### 3.1 Definitions of Terms Specific to This Standard:

3.1.1 *bar, n*—material of rectangular (flats) or square solid section up to and including 10 in. (254 mm) in width and 1/8 in. (3.2 mm) and over in thickness in straight lengths.

3.1.1.1 *Discussion*—Hot-worked rectangular bar in widths 10 in. (254 mm) and under may be furnished as hot-rolled plate

**TABLE 1 Conditions for Hot-Worked Rod and Bar and Cold-Worked Rod<sup>A</sup>**

Diameter or Distance Between Parallel Surfaces, in. (mm)	Tensile Strength min, ksi (MPa)	Yield Strength (0.2 % offset), min, ksi (MPa)	Elongation in 2 in. or 50 mm or 4D, min, %
UNS N06625 Grade 1 (Annealed) <sup>B</sup>			
Up to 4 (102), incl	120 (827)	60 (414)	30
Over 4 (102) to 10 (254), incl	110 (758)	50 (345)	25
UNS N06625 Grade 2 (Solution Annealed) <sup>C</sup>			
All sizes	100 (690)	40 (276)	30
UNS N06219 All (Solution Annealed)			
All sizes	96 (660)	39 (270)	50
UNS N06650 All (Solution Annealed)			
All sizes	116 (800)	58 (400)	45

<sup>A</sup> Forging quality is furnished to chemical requirements and surface inspection only. No tensile properties are required. Forging stock is typically supplied in the hot worked condition, (see X1.1.5).

<sup>B</sup> Annealed 1600°F (871°C) minimum.

<sup>C</sup> Solution annealed at 2000°F (1093°C) minimum, with or without subsequent stabilization anneal at 1800°F (982°C) minimum to increase resistance to sensitization.

**TABLE 2 Chemical Requirements**

Element	Composition Limits, %		
	N06625	N06219	N06650
Carbon	0.10 max	0.05 max	0.03 max
Manganese	0.50 max	0.50 max	0.50 max
Silicon	0.50 max	0.70-1.10	0.50 max
Phosphorus	0.015 max	0.020 max	0.020 max
Sulfur	0.015 max	0.010 max	0.010 max
Chromium	20.0 min	18.0-22.0	19.0-21.0
Columbium + tantalum	23.0 max	...	...
	3.15 min	...	0.05-0.50
Cobalt (if determined)	4.15 max	...	...
	1.0 max	1.0 max	1.0 max
Molybdenum	8.0 min	7.0-9.0	9.5-12.5
	10.0 max	...	...
Iron	5.0 max	2.0-4.0	12.0-16.0
Aluminum	0.40 max	0.50 max	0.05-0.50
Titanium	0.40 max	0.50 max	...
Copper	...	0.50 max	0.30 max
Nickel <sup>A</sup>	58.0 min	Bal.	Bal.
Tungsten	...	...	0.50-2.50
Nitrogen	...	...	0.05-0.20

<sup>A</sup> Element shall be determined arithmetically by difference.

**TABLE 3 Permissible Variations in Diameter of Cold-Worked Rod**

Specified Dimension, in. (mm)	Permissible Variations from Specified Dimension, in. (mm)	
	Plus	Minus
1/16 (1.6) to 3/16 (4.8), excl	0	0.002 (0.05)
3/16 (4.8) to 1/2 (12.7), excl	0	0.003 (0.08)
1/2 (12.7) to 15/16 (23.8), incl	0.001 (0.03)	0.002 (0.05)
Over 15/16 (23.8) to 1 1/16 (49.2), incl	0.0015 (0.04)	0.003 (0.08)
Over 1 1/16 (49.2) to 2 1/2 (63.5), incl	0.002 (0.05)	0.004 (0.10)

with sheared or cut edges in accordance with Specification B443, provided the mechanical property requirements of this specification are met.

3.1.2 *rod, n*—material of round solid section furnished in straight lengths.

**TABLE 4 Permissible Variations in Diameter or Distance Between Parallel Surfaces of Hot-Worked Rod and Bar**

Specified Dimension, in. (mm) <sup>A</sup>	Permissible Variations from Specified Dimensions, in. (mm)	
	Plus	Minus
Rod and bar, hot-worked:		
1 (25.4) and under	0.016 (0.41)	0.016 (0.41)
Over 1 (25.4) to 2 (50.8), incl	0.031 (0.79)	0.016 (0.41)
Over 2 (50.8) to 4 (101.6), incl	0.047 (1.19)	0.031 (0.79)
Over 4 (101.6)	0.125 (3.18)	0.063 (1.60)
Rod, rough-turned or ground:		
Under 1 (25.4)	0.005 (0.13)	0.005 (0.13)
1 (25.4) and over	0.031 (0.79)	0
Forging quantity rod: <sup>B</sup>		
Under 1 (25.4)	0.005 (0.13)	0.005 (0.13)
1 (25.4) and over	0.031 (0.79)	0

<sup>A</sup> Dimensions apply to diameter of rods, to distance between parallel surfaces of squares, and separately to width and thickness of rectangles.

<sup>B</sup> Spot grinding is permitted to remove minor surface imperfections. The depth of these spot ground areas shall not exceed 3 % of the diameter of the rod.

#### 4. Ordering Information

4.1 It is the responsibility of the purchaser to specify all requirements that are necessary for the safe and satisfactory performance of material ordered under this specification. Examples of such requirements include, but are not limited to, the following:

4.1.1 ASTM designation,

4.1.2 UNS number,

4.1.3 *Section*—Rod (round) or bar (square or rectangular),

4.1.4 *Dimensions*, including length,

4.1.5 Condition (see 1.1.1, 1.1.2, and appendix),

4.1.5.1 If neither grade of N06625 is specified, Grade 1 will be supplied,

4.1.6 *Finish* (Section 8),

4.1.7 *Quantity*—Feet (or metres) or number of pieces,

4.1.8 *Samples for Product (Check) Analysis*—State whether samples for product (check) analysis should be furnished (see 5.2), and

4.1.9 *Product Marking* (see Section 16)—State product marking requirements.

4.1.10 *Purchaser Inspection* (see Section 13)—If purchaser wishes to witness tests or inspection of material at place of manufacture, the purchase order must so state, indicating which test or inspections are to be witnessed.

#### 5. Chemical Composition

5.1 The material shall conform to the composition limits specified in Table 2.

5.2 If a product (check) analysis is performed by the purchaser, the material shall conform to the product (check) analysis variations in Specification B880.

#### 6. Mechanical Properties and Other Requirements

6.1 *Mechanical Properties*—The material shall conform to the heat treatment and room temperature tensile properties prescribed in Table 1.

## 7. Dimensions and Permissible Variations

7.1 *Diameter, Thickness, or Width*—The permissible variations from the specified dimensions of cold-worked rod shall be as prescribed in Table 3, and of hot-worked rod and bar as prescribed in Table 4.

7.2 *Out-of-Round*—Hot-worked rods and cold-worked rods (except “forging quality”) all sizes, in straight lengths, shall not be out-of-round by more than one half the total permissible variations in diameter shown in Tables 3 and 4, except for hot-worked rods ½ in. (12.7 mm) in diameter and under, which may be out-of-round by the total permissible variations in diameter shown in Table 4.

7.3 *Machining Allowances for Hot-Worked Materials*—When the surfaces of hot-worked products are to be machined, the allowances prescribed in Table 5 are recommended for normal machining operations.

7.4 *Length*—The permissible variations in length of cold-worked and hot-worked rod and bar shall be as prescribed in Table 6.

7.4.1 Rods and bars ordered to random or nominal lengths will be furnished with either cropped or saw-cut ends; material ordered to cut lengths will be furnished with square saw-cut or machined ends.

### 7.5 Straightness:

7.5.1 The permissible variations in straightness of cold-worked rod as determined by the departure from straightness shall be as prescribed in Table 7.

7.5.2 The permissible variations in straightness of hot-worked rod and bar as determined by the departure from straightness shall be as specified in Table 8.

## 8. Workmanship, Finish, and Appearance

8.1 The material shall be uniform in quality and condition, smooth, commercially straight or flat, and free of injurious imperfections.

## 9. Sampling

### 9.1 Lot—Definition:

9.1.1 A lot for chemical analysis shall consist of one heat.

9.1.2 A lot for mechanical properties testing shall consist of all material from the same heat, nominal diameter or thickness, and condition.

### 9.1.2.1 DELETED

### 9.2 Test Material Selection:

9.2.1 *Chemical Analysis*—Representative samples from each lot shall be taken during pouring or subsequent processing.

9.2.1.1 Product (check) analysis shall be wholly the responsibility of the purchaser.

9.2.2 *Mechanical Properties*—Samples of the material to provide test specimens for mechanical properties shall be taken from such locations in each lot as to be representative of that lot.

## 10. Number of Tests

10.1 *Chemical Analysis*—One test per lot.

10.2 *Tension*—One test per lot.

## 11. Specimen Preparation

11.1 Tension test specimens shall be taken from material in the final condition and tested in the direction of fabrication.

11.1.1 All rod and bar shall be tested in full cross section size when possible. When a full cross section size test cannot be performed, the largest possible round specimen shown in Test Methods E8/E8M shall be used. Longitudinal strip specimens shall be prepared in accordance with Test Methods E8/E8M for rectangular bar up to ½ in. (12.7 mm), inclusive, in thicknesses that are too wide to be pulled full size.

## 12. Test Methods

12.1 The chemical composition and mechanical and other properties of the material as enumerated in this specification shall be determined, in case of disagreement, in accordance with the following ASTM standards:

TABLE 5 Normal Machining Allowances for Hot-Worked Material

Finished-Machined Dimensions for Finishes As Indicated below, in. (mm) <sup>A</sup>	On Diameter, For Rods	Normal Machining Allowance, in. (mm)		
		Distance Between Parallel Surfaces of Square Bars	For Rectangular Bar	
			On Thickness	On Width
Hot-worked: <sup>B</sup>				
Up to 7/8 (22.2), incl	1/8 (3.2)	1/8 (3.2)	1/8 (3.2)	3/16 (4.8)
Over 7/8 to 1 1/8 (22.2 to 47.6), incl	1/8 (3.2)	3/16 (4.8)	1/8 (3.2)	3/16 (4.8)
Over 1 1/8 to 2 1/8 (47.6 to 73.0), incl	3/16 (4.8)	1/4 (6.4)	...	3/16 (4.8)
Over 2 1/8 to 3 1/4 (73.0 to 96.8), incl	1/4 (6.4)	...	...	3/16 (4.8)
Over 3 1/4 (96.8)	1/4 (6.4)	...	...	3/8 (9.5)
Hot-worked rods, rough-turned or rough ground: <sup>C</sup>				
1 5/16 to 4 (23.8 to 101.6), incl in diameter	1/16 (1.6)	...	...	...
Over 4 to 12 (101.6 to 304.8), incl in diameter	1/8 (3.2)	...	...	...

<sup>A</sup> Dimensions apply to diameter of rods, to distance between parallel surfaces of square bar, and separately to width and thickness of rectangular bar.

<sup>B</sup> The allowances for hot-worked material in Table 5 are recommended for rods machined in lengths of 3 ft (0.91 m) or less and for bars machined in lengths of 2 ft (0.61 m) or less. Hot-worked material to be machined in longer lengths should be specified showing the finished cross-sectional dimension and the length in which the material will be machined in order that the manufacturer may supply material with sufficient oversize, including allowance for out-of-straightness.

<sup>C</sup> Applicable to 3 ft (0.91 m) max length.

**TABLE 6 Permissible Variations in Length of Rods and Bars**

Random mill lengths:
Hot-worked <sup>A</sup>
6 to 24 ft (1.83 to 7.31 m) long with not more than 25 weight % between 6 and 9 ft (1.83 and 2.74 m). <sup>B</sup>
Cold-worked
6 to 20 ft (1.83 to 6.1 m) long with not more than 25 weight % between 6 and 10 ft (1.83 and 3.05 m).
Multiple lengths
Furnished in multiples of a specified unit length, within the length limits indicated above. For each multiple, an allowance of ¼ in. (6.4 mm) will be made for cutting, unless otherwise specified. At the manufacturer's option, individual specified unit lengths may be furnished.
Nominal lengths
Specified nominal lengths having a range of not less than 2 ft. (610 mm) with no short lengths allowed. <sup>A</sup>
Cut lengths
A specified length to which all rods and bars will be cut with a permissible variation of plus ⅛ in. (3.2 mm), minus 0 for sizes 8 in. (203 mm) and less in diameter or distance between parallel surfaces. For larger sizes, the permissible variation shall be +¼ in. (6.4 mm), -0.

<sup>A</sup> For cold-worked rod under ½ in. (12.7 mm) in diameter ordered to nominal or stock lengths with a 2-ft (610-mm) range, at least 93 % of such material shall be within the range specified; the balance may be in shorter lengths but in no case shall lengths less than 4 ft (1220 mm) be furnished.

<sup>B</sup> For hot-worked sections weighing over 25 lb/ft (37 kg/m) and for smooth forged products, all sections, short lengths down to 2 ft (610 mm) may be furnished.

**TABLE 7 Permissible Variations in Straightness of Cold-Worked Rods**

Specified Diameter, in. (mm) <sup>A</sup>	Permissible Variations, in. (mm)
½ (12.7) to 2½ (63.5), incl	Depth of Chord: 0.030 (0.76) per ft (305 mm) of length

<sup>A</sup> Material under ½ in. (12.7 mm) shall be reasonably straight and free of sharp bends and kinks.

**TABLE 8 Permissible Variations in Straightness of Hot-Worked Rods and Bars<sup>A</sup>**

Finish	Permissible Variations, in./ft (mm/m) <sup>B</sup>
Rods and bars, hot-worked	0.050 (4.2) <sup>C</sup>
Rounds—hot-worked, rough ground or rough turned	0.050 (4.2) <sup>C</sup>

<sup>A</sup> Not applicable to forging quality.

<sup>B</sup> Material under ½ in. (12.7 mm) shall be reasonably straight and free of sharp bends and kinks.

<sup>C</sup> The maximum curvature (depth of chord) shall not exceed the values indicated multiplied by the length in feet.

Test	ASTM Designation
Chemical analysis	E1473
Tension	E8/E8M
Rounding procedure	E29

12.2 For purposes of determining compliance with the specified limits for requirements of the properties listed in the following table, an observed or calculated value shall be rounded as indicated below, in accordance with the rounding method of Practice E29:

Test	Rounded Unit for Observed or Calculated Value
Chemical composition and tolerances (when expressed in decimals)	Nearest unit in the last right-hand place of figures of the specified limit. If two choices are possible, as when the digits dropped are exactly a 5, or a 5 followed only by zeros, choose the one ending in an even digit, with zero defined as an even digit.
Tensile strength and yield strength	Nearest 1000 psi (6.9 MPa)

**13. Inspection**

13.1 Inspection of the material shall be made as agreed upon between the manufacturer and the purchaser as part of the purchase contract.

**14. Rejection and Reheating**

14.1 Material tested by the purchaser that fails to conform to the requirements of this specification may be rejected. Rejection should be reported to the producer or supplier promptly and in writing. In case of dissatisfaction with the results of the test, the producer or supplier may make claim for a reheating.

**15. Certification**

15.1 A manufacturer's certification shall be furnished to the purchaser stating that the material was manufactured, tested, and inspected in accordance with this specification and that test results on representative samples meet specification requirements. A report of the test results shall be furnished.

**16. Product Marking**

16.1 The following information shall be marked on the material or included on the package, or on a label or tag attached thereto: The name of the material or UNS number; heat number; condition (temper); this specification number; the size; gross, tare and net weight; consignor and consignee address; contract or order number; or such other information as may be defined in the contract or order.

**17. Keywords**

17.1 bar; rod; UNS N06625; UNS N06219; UNS N06650

## APPENDIX

## (Nonmandatory Information)

## X1. PROCURABLE CONDITIONS AND FINISHES

X1.1 The various conditions and finishes in which rod and bar are procurable are as follows:

X1.1.1 *Hot Finished, Annealed, or Solution-Annealed*—Soft, with a tightly adherent dark oxide.

X1.1.2 *Hot Finished, Annealed or Solution Annealed, and Pickled*—Same as X1.1.1 except descaled for removal of mill oxide. Provides for better surface inspection than does hot-worked, annealed material and often employed where welding is involved where removal of mill oxide is desired.

NOTE X1.1—Annealing or solution annealing prior to pickling may be required in order to reduce the mill oxide since uniform pickling of an unreduced oxide is difficult.

X1.1.3 *Hot-Worked, Annealed, and Rough Ground*—Similar to X1.1.1 except rough ground.

X1.1.4 *Hot-Worked, Annealed, and Rough-Turned*—Similar to X1.1.1 except rough turned with a broad nosed tool similar

to a bar peeling operation and thus may not be straight. Intended generally for machining where an overhauled surface is desired, essentially for machined step down shafts or parts machined in short lengths of 3 ft (0.91 m) or less.

X1.1.5 *Hot-Worked, Forging Quality*—Rough turned and spot ground, as necessary, for sizes 1 in. (25.4 mm) in diameter and over; rough ground and spot ground for sizes under 1 in. in diameter. Material is selected from heats of known, good hot malleability.

NOTE X1.2—For sizes 2½ in. (63.5 mm) in diameter and less, cold-worked rod may be used also for forging by virtue of the fact such rod have been overhauled for removal of mechanical surface defects prior to cold-working. In such cases, the user should run pilot forging tests to ensure himself that such material has the desired hot malleability range.

X1.1.6 *Cold-Drawn, Annealed, or Solution-Annealed, and Pickled*—Hot finished, overhauled, cold-drawn, annealed or solution-annealed, descaled, and straightened.

**SPECIFICATION FOR FORGED OR ROLLED NICKEL  
ALLOY PIPE FLANGES, FORGED FITTINGS, AND  
VALVES AND PARTS FOR CORROSIVE  
HIGH-TEMPERATURE SERVICE**



**SB-462**

(Identical with ASTM Specification B462-18<sup>1</sup> except that certification and a test report have been made mandatory.)

# Specification for Forged or Rolled Nickel Alloy Pipe Flanges, Forged Fittings, and Valves and Parts for Corrosive High-Temperature Service

## 1. Scope

1.1 This specification covers forged or rolled UNS N06030, UNS N06035, UNS N06022, UNS N06200, UNS N06059, UNS N10362, UNS N06686, UNS N08020, UNS N08367, UNS N10276, UNS N10665, UNS N10675, UNS N10629, UNS N08031, UNS N06045, UNS N06025, UNS N06699, and UNS R20033 pipe flanges, forged fittings, and valves and parts intended for corrosive high-temperature service.

1.2 The values stated in inch-pound units are to be regarded as standard. The values given in parentheses are mathematical conversions to SI units that are provided for information only and are not considered standard.

1.3 *This standard does not purport to address all of the safety concerns, if any, associated with its use. It is the responsibility of the user of this standard to become familiar with all hazards including those identified in the appropriate Safety Data Sheet (SDS) for this product/material as provided by the manufacturer, to establish appropriate safety, health, and environmental practices, and determine the applicability of regulatory limitations prior to use.*

1.4 *This international standard was developed in accordance with internationally recognized principles on standardization established in the Decision on Principles for the Development of International Standards, Guides and Recommendations issued by the World Trade Organization Technical Barriers to Trade (TBT) Committee.*

## 2. Referenced Documents

### 2.1 ASTM Standards:

- A262 Practices for Detecting Susceptibility to Intergranular Attack in Austenitic Stainless Steels
- B166 Specification for Nickel-Chromium-Aluminum Alloy, Nickel-Chromium-Iron Alloys, Nickel-Chromium-Cobalt-Molybdenum Alloy, Nickel-Iron-Chromium-Tungsten Alloy, and Nickel-Chromium-Molybdenum-Copper Alloy Rod, Bar, and Wire
- B335 Specification for Nickel-Molybdenum Alloy Rod
- B408 Specification for Nickel-Iron-Chromium Alloy Rod and Bar
- B472 Specification for Nickel Alloy Billets and Bars for Reforging
- B473 Specification for UNS N08020, UNS N08024, and UNS N08026 Nickel Alloy Bar and Wire
- B574 Specification for Low-Carbon Nickel-Chromium-Molybdenum, Low-Carbon Nickel-Molybdenum-Chromium, Low-Carbon Nickel-Molybdenum-Chromium-Tantalum, Low-Carbon Nickel-Chromium-Molybdenum-Copper, and Low-Carbon Nickel-Chromium-Molybdenum-Tungsten Alloy Rod
- B581 Specification for Nickel-Chromium-Iron-Molybdenum-Copper Alloy Rod
- B649 Specification for Ni-Fe-Cr-Mo-Cu-N Low-Carbon Alloys (UNS N08925, UNS N08031, UNS N08034, UNS N08354, and UNS N08926), and Cr-Ni-Fe-N Low-Carbon Alloy (UNS R20033) Bar and Wire, and Ni-Cr-Fe-Mo-N Alloy (UNS N08936) Wire
- B691 Specification for Iron-Nickel-Chromium-Molybdenum Alloys (UNS N08367) Rod, Bar, and Wire
- B880 Specification for General Requirements for Chemical Check Analysis Limits for Nickel, Nickel Alloys and Cobalt Alloys

TABLE 1 Chemical Requirements

Element	Composition, %		
	UNS N08020	UNS N08367	UNS R20033
Carbon, max	0.07	0.030	0.015
Manganese, max	2.00	2.00	2.0
Phosphorus, max	0.045	0.040	0.02
Sulfur, max	0.035	0.030	0.01
Silicon, max	1.00	1.00	0.50
Nickel	32.00–38.00	23.50 to 25.50	30.0–33.0
Chromium	19.00–21.00	20.00 to 22.00	31.0–35.0
Molybdenum	2.00–3.00	6.00 to 7.00	0.50–2.0
Copper	3.00–4.00	0.75 max	0.30–1.20
Columbium (Nb) + tantalum	8 × carbon–1.00	...	...
Nitrogen	...	0.18 to 0.25	0.35–0.60
Iron	Remainder <sup>A</sup>	Remainder <sup>A</sup>	Remainder

Element	Composition, %					
	UNS N06030	UNS N06022	UNS N06200	UNS N10276	UNS10665	UNS N10675
Carbon, max	0.03	0.015	0.010	0.010	0.02	0.01
Manganese, max	1.5	0.50	0.50	1.0	1.0	3.0
Phosphorous, max	0.04	0.02	0.025	0.04	0.04	0.030
Sulphur, max	0.02	0.02	0.010	0.03	0.03	0.010
Silicon, max	0.8	0.08	0.08	0.08	0.10	0.10
Nickel	Remainder <sup>A</sup>	Remainder <sup>A</sup>	Remainder <sup>A</sup>	Remainder <sup>A</sup>	Remainder <sup>A</sup>	Remainder <sup>A</sup>
Chromium	28.0-31.5	20.0-22.5	22.0–24.0	14.5-16.5	1.0 max	1.0-3.0
Molybdenum	4.0-6.0	12.5-14.5	15.0-17.0	15.0-17.0	26.0-30.0	27.0-32.0
Copper	1.0-2.4	...	0.3-1.9	...	...	0.20
Columbium (Nb) + tantalum	0.30-1.50	...	...	...	...	...
Nitrogen	...	...	...	...	...	...
Iron	13.0-17.0	2.0-6.0	3.0 max	4.0-7.0	2.0 max	1.0-3.0
Cobalt, max	5.0	2.5	2.0	2.5	1.0	3.0
Tungsten	1.5-4.0	2.5-3.5	...	3.0-4.5	...	3.0 max
Vanadium, max	...	0.35	...	0.35	...	0.20
Titanium, max	...	...	...	...	...	0.2
Zirconium, max	...	...	...	...	...	0.10
Columbium (Nb)	...	...	...	...	...	0.20 max
Tantalum	...	...	...	...	...	0.20 max
Nickel + Molybdenum	...	...	...	...	...	94.0-98.0
Aluminum, max	...	...	0.50	...	...	0.50

Element	Composition, %									
	UNS N06699	UNS N06059	UNS N10362	UNS N06686	UNS N08031	UNS N06045	UNS† N06025	UNS† N10629	UNS† N06035	
Carbon, max	0.005-0.10	0.010	0.010	0.010	0.015	0.05-0.12	0.15-0.25	0.01	0.050	
Manganese, max	0.50	0.5	0.60	0.75	2.0	1.0	0.15	1.5	0.50	
Phosphorous, max	0.02	0.015	0.025	0.04	0.020	0.02	0.02	0.040	0.030	
Sulphur, max	0.01	0.010	0.010	0.02	0.010	0.010	0.010	0.010	0.015	
Silicon, max	0.50	0.10	0.08	0.08	0.3	2.5-3.0	0.5	0.05	0.60	
Nickel	Remainder <sup>A</sup>	Remainder <sup>A</sup>	Remainder <sup>A</sup>	Remainder <sup>A</sup>	30.0-32.0	45.0 min	Remainder <sup>A</sup>	Remainder <sup>A</sup>	Remainder <sup>A</sup>	
Chromium	26.0-30.0	22.0-24.0	13.8-15.6	19.0-23.0	26.0-28.0	26.0-29.0	24.0-26.0	0.5-1.5	32.25-34.25	
Molybdenum	...	15.0-16.5	21.5-23.0	15.0-17.0	6.0-7.0	...	...	26.0-30.0	7.60-9.00	
Copper	0.50 max	0.50 max	...	...	1.0-1.4	0.3 max	0.1 max	0.5	0.30 max	
Yttrium	...	...	...	...	...	...	0.05-0.12	...	...	
Nitrogen	0.05 max	...	...	...	0.15-0.25	...	...	...	...	
Iron	2.5 max	1.5 max	1.25 max	5.0 max	Remainder <sup>A</sup>	21.0-25.0	8.0–11.0	1.0-6.0	2.00 max	
Cobalt, max	...	0.3	...	...	...	...	...	2.5	1.00	
Tungsten	...	...	...	3.0-4.4	...	...	...	...	0.60 max	
Vanadium, max	...	...	...	...	...	...	...	...	0.20	
Titanium, max	0.60	...	...	0.02-0.25	...	...	0.1-0.2	...	...	
Zirconium, max	0.10	...	...	...	...	...	0.01-0.10	...	...	
Columbium (Nb)	0.50 max	...	...	...	...	...	...	...	...	
Tantalum	...	...	...	...	...	...	...	...	...	
Cerium	...	...	...	...	...	0.03-0.09	...	...	...	
Aluminum, max	1.9-3.0	0.1-0.4	0.50	...	...	...	1.8-2.4	0.1-1.5	0.40	
Boron	0.008 max	...	...	...	...	...	...	...	...	

<sup>A</sup> Shall be determined arithmetically by difference.

† Editorially corrected.

E8/E8M Test Methods for Tension Testing of Metallic Materials

E527 Practice for Numbering Metals and Alloys in the Unified Numbering System (UNS)

E1473 Test Methods for Chemical Analysis of Nickel, Cobalt and High-Temperature Alloys

E1916 Guide for Identification of Mixed Lots of Metals

2.2 *ANSI Standard:*

B16.5 Steel Pipe Flanges and Flanged Fittings (for applicable alloy UNS N08020)

2.3 *Manufacturers' Standardization Society of the Valve and Fittings Industry Standard:*

SP-25 Standard Marking System for Valves, Fittings, Flanges, and Unions

### 3. Terminology

3.1 *Definitions of Terms Specific to This Standard:*

3.1.1 *forgings, n*—the term forgings as used in this specification shall be understood to cover one or all of the products mentioned in 1.1, either forged or rolled.

### 4. Ordering Information

4.1 It is the responsibility of the purchaser to specify all requirements that are necessary for material ordered under this specification. Examples of such requirements include, but are not limited to, the following:

4.1.1 Quantity (weight or number of pieces),

4.1.2 Name of material or UNS number,

4.1.3 Forging sketch when required (5.2.4),

4.1.4 Forging sectioning, if required (5.2.3),

4.1.5 ASTM designation and year of issue,

4.1.6 Inspection (14.1),

4.1.7 Supplementary requirements, if any, and

4.1.8 If possible, the intended end use.

NOTE 1—A typical ordering description is as follows: 200 forgings, UNS N08020, in accordance with the attached drawing and Specification B462.

### 5. Materials and Manufacture

5.1 *Discard*—A sufficient discard shall be made from each ingot to secure freedom from injurious piping and undue segregation. The material shall have a homogeneous structure as shown by the macroetch test in 7.3.

5.2 *Manufacturing Practice:*

5.2.1 Material for forging shall consist of a billet, bar, or forging produced in accordance with Specifications B166, B335, B408, B462, B472, B473, B574, B581, B649, or B691.

5.2.2 The material shall be forged by hammering, pressing, rolling, extruding, or upsetting; it shall be brought as nearly as practicable to the finished shape and size by hot working; and shall be so processed as to cause metal flow during the hot-working operation in the direction most favorable for resisting the stresses encountered in service.

5.2.3 When specified in the order, a sample forging may be sectioned and etched to show flow lines and the condition as regards internal imperfections. In such cases, the question of acceptable and unacceptable character of metal flow shall be a subject for agreement between the manufacturer and the purchaser.

5.2.4 When specified in the order, the manufacturer shall submit for approval of the purchaser a sketch showing the shape of the rough forging before machining.

5.3 *Heat Treatment:*

5.3.1 The product of UNS N08020 alloy shall be furnished in the stabilized-annealed condition. The product of UNS N06022, UNS N06035, UNS N06030, UNS N06200, UNS N10362, UNS N10276, UNS N10665, UNS N10675, UNS N06699, and UNS R20033 alloys shall be furnished in the solution annealed condition.

NOTE 2—The recommended annealing temperatures all followed by water quenching or rapidly cooling by other means are: UNS N06030—2125 to 2175°F (1163 to 1191°C), UNS N06022—2025 to 2075°F (1107 to 1135°C), UNS N06035—2025–2075°F (1107–1135°C), UNS N06200—2075 to 2125°F (1135 to 1163°C), UNS N06059—2025 to 2125°F (1107 to 1163°C), UNS N10362—2075 to 2125°F (1135 to 1163°C), UNS N06686—2125 to 2225°F (1163 to 1218°C), UNS N08020—1700 to 1850°F (927 to 1010°C), UNS N10276—2025 to 2075°F (1107 to 1135°C), UNS N10665—1925 to 2000°F (1052 to 1093°C), UNS N10675—1925 to 2000°F (1052 to 1093°C), UNS N10629—1925 to 2000°F (1052 to 1093°C), UNS N08031—2050 to 2160°F (1121 to 1182°C) UNS N06045—2125 to 2190°F (1163 to 1199°C), UNS N06025—2175 to 2240°F (1191 to 1227°C), UNS N06699—1975 to 2065°F (1080 to 1130°C), and UNS R20033—2010 to 2150°F (1100 to 1180°C).

5.3.2 Alloy N08367 shall be furnished in the solution annealed condition.

5.3.2.1 The recommended heat treatment shall consist of heating to a minimum temperature of 2025°F (1105°C) and quenching in water, or rapidly cooling, by other means.

5.3.3 Heat treatment may be performed before machining.

### 6. Chemical Composition

6.1 The material shall conform to the requirements as to chemical composition prescribed in Table 1.

6.2 If a product (check) analysis is performed by the purchaser, the material shall conform to the requirements specified in Table 1 subject to the permissible tolerances in Specification B880.

## 7. Mechanical Properties and Other Requirements

7.1 *Mechanical Properties*—The material shall conform to the requirements as to mechanical properties prescribed in Table 2 at room temperature.

7.2 *Hydrostatic Tests*—After machining, valve bodies, fittings, and other pressure-containing parts shall be tested to the hydrostatic shell-test pressures prescribed in ANSI B16.5 for the applicable alloy steel rating for which the forging is designed and shall show no leaks. Forgings ordered under these specifications for working pressures other than those listed in the American National Standard ratings shall be tested to such pressures as may be agreed upon between the manufacturer and the purchaser.

7.2.1 No hydrostatic test is required for welding neck or other flanges.

7.2.2 The forging manufacturer is not required to perform pressure tests on rough forgings that are to be finally machined by others. The fabricator of finished forged parts is not required to pressure-test forgings that are designed to be pressure containing only after assembly by welding into a larger structure. However, the manufacturer of such forgings is responsible as required in accordance with 15.1 for the satisfactory performance of the forgings under the final test required in 7.2.

7.3 *Macroetch Tests*—Etching of tests shall show sound and reasonably uniform material, free of injurious laminations, cracks, segregations, and similar objectionable defects. If, on successive tests, 10 % of any heat fails to pass the requirements of the macroetch test, all forgings from that heat shall be rejected.

## 8. Dimensions and Permissible Variations

8.1 The forgings shall conform to the sizes and shapes specified by the purchaser.

## 9. Workmanship, Finish, and Appearance

9.1 The forgings shall be uniform in quality and condition, and shall be free of injurious defects.

## 10. Sampling

10.1 *Lot*—Definition:

10.1.1 A lot for chemical analysis shall consist of one heat.

10.1.2 A lot for mechanical properties shall consist of each heat in each heat-treatment charge.

10.2 *Test Material Selection*:

10.2.1 *Chemical Analysis*—Representative samples shall be taken during pouring or subsequent processing.

10.2.1.1 *Check analysis*, shall be wholly the responsibility of the purchaser.

10.2.2 *Mechanical Properties*—Samples of the material to provide test specimens shall be taken from such locations in each lot as to be representative of that lot.

## 11. Number of Tests

11.1 *Chemical Analysis*—One test per lot.

11.2 *Mechanical Properties*—One test per lot.

## 12. Specimen Preparation

12.1 The tension test specimens taken from the forgings, billets, or bars shall be machined to the form and dimensions of the standard 2-in. (50.8-mm) gage length tension test specimen shown in the figure titled Standard 0.500 in. Round Tension Test Specimen with 2 in. Gage Length and Examples of Small-Size Specimens Proportional to the Standard Specimen of Test Methods E8/E8M, except as specified in 12.2.

12.2 In the case of small sections that will not permit taking the standard test specimen specified in 12.1, the tension test specimen shall be as large as feasible and its dimensions shall be proportional to those shown in the figure titled Standard 0.500 in. Round Tension Test Specimen with 2 in. Gage Length and Examples of Small-Size Specimens Proportional to the

TABLE 2 Mechanical Property Requirements

Alloy	Tensile Strength, min		Yield Strength, min		Elongation in 2 in. or 50 mm, min, %	Reduction of Area, min, %
	ksi	MPa	ksi	MPa		
UNS N08020	80	551	35	241	30.0	50.0
UNS N08367	95	655	45	310	30.0	50.0
UNS R20033	109	750	55	380	40.0	...
UNS N06030	85	586	35	241	30	...
UNS N06022	100	690	45	310	45	...
UNS N06035	85	586	35	241	30	...
UNS N06200	100	690	45	310	45	...
UNS N10276	100	690	41	283	40	...
UNS N10665	110	760	51	350	40	...
UNS N10675	110	760	51	350	40	...
UNS N06059	100	690	45	310	45	...
UNS N10362	105	725	45	310	40	...
UNS N06686	100	690	45	310	45	...
UNS N08031	94	650	40	276	40.0	...
UNS N06045	90	620	35	241	35	...
UNS N06025	98	680	39	270	30	...
UNS N10629	110	760	51	350	40	...
UNS N06699	89	610	35	240	40	...

Standard Specimen of Test Methods E8/E8M. The gage length for measuring elongation shall be four times the diameter of the specimen.

12.3 For the purpose of tests, the necessary extra forgings or test bars shall be provided. The test specimen, if cut from a flange, shall be cut tangentially from the flange portion approximately midway between the inner and outer surfaces and approximately midway between the front and back faces. When it is impractical to provide forgings for test purposes, test bars may be made from the billet or bar, provided they are given approximately the same reduction and heat treatment as the forgings.

### 13. Tests Methods

13.1 The chemical composition and mechanical properties of the material as enumerated in this specification shall, in case of disagreement, be determined in accordance with the following methods:

Test	ASTM Designations
Chemical analysis	E1473 <sup>A</sup>
Tension	E8/E8M

<sup>A</sup> Iron shall be determined arithmetically by difference.

### 14. Inspection

14.1 If specified, source inspection of the material by the purchaser at the manufacturer's plant shall be made as agreed upon between the manufacturer and the purchaser as part of the purchase contract.

### 15. Rejection and Rehearing

15.1 Material that fails to conform to the requirements of this specification may be rejected. Rejection should be reported to the producer or supplier promptly and in writing. In case of dissatisfaction with the results of the test, the producer or supplier may make claim for a rehearing.

### 16. Certification

16.1 A producer's or supplier's certification shall be furnished to the purchaser that the material was manufactured, sampled, tested, and inspected in accordance with this specification and has been found to meet the requirements. A report of the test results shall be furnished.

### 17. Product Marking

17.1 Identification marks consisting of the manufacturer's symbol or name, designation of service rating, the specification, the grade of material, and the size shall be stamped legibly on each forging in accordance with MSS SP-25 and in such position as not to injure the usefulness of the forging.

### 18. Keywords

18.1 forgings; UNS N06030; UNS N06022; UNS N06035; UNS N06200; UNS N06059; UNS N10362; UNS N06686; UNS N08020; UNS N08367; UNS N10276; UNS N10665; UNS N10675; UNS N10629; UNS N08031; UNS N06045; UNS N06025; UNS N06699; UNS R20033

## SUPPLEMENTARY REQUIREMENTS

The following supplementary requirements shall be applied only when specified by the purchaser in the inquiry, contract, or order.

### S1. Corrosion Tests for UNS N08020

S1.1 One intergranular corrosion test per heat shall be performed by the manufacturer on a sensitized specimen and tested in accordance with Practices A262. When this supplementary requirement is specified, the specific practice (Practice B or Practice E) shall also be specified. If Practice B is specified, the specimen must pass with a rate of less than 0.002 inches per month (ipm).

S1.1.1 In addition to the stabilize anneal, the specimen shall be sensitized for 1 h at 1250°F (677°C) before being subjected to corrosion testing.

### S2. Positive Material Identification Examination

S2.1 Product shall receive Positive Material Identification to ensure that the purchaser is receiving product of the correct material grade prior to shipment of the product. This exami-

nation is a method to assure that no material grade mix-up has happened during manufacturing and marking of the product.

S2.2 Product shall receive a Positive Material Identification examination by Guide E1916.

S2.3 The quantity examined shall be 100 % of the product.

S2.4 All product that is not of the correct material grade shall be rejected.

S2.5 The method of product marking after examination shall be agreed upon between the manufacturer and purchaser.

# SPECIFICATION FOR UNS N08020 ALLOY PLATE, SHEET, AND STRIP



SB-463



(Identical with ASTM Specification B463-10(2016).)

ASMENORMDOC.COM : Click to view the full PDF of ASME BPVC.II.B (ASME BPVC Section II part B) 2025

# Specification for UNS N08020 Alloy Plate, Sheet, and Strip

## 1. Scope

1.1 This specification covers UNS N08020 alloy plate, sheet, and strip.

1.2 The values stated in inch-pound units are to be regarded as standard. The values given in parentheses are mathematical conversions to SI units that are provided for information only and are not considered standard.

1.3 *This standard does not purport to address all of the safety concerns, if any, associated with its use. It is the responsibility of the user of this standard to become familiar with all hazards including those identified in the appropriate Safety Data Sheet (SDS) for this product/material as provided by the manufacturer, to establish appropriate safety and health practices, and determine the applicability of regulatory limitations prior to use.*

## 2. Referenced Documents

### 2.1 ASTM Standards:

A262 Practices for Detecting Susceptibility to Intergranular Attack in Austenitic Stainless Steels

B906 Specification for General Requirements for Flat-Rolled Nickel and Nickel Alloys Plate, Sheet, and Strip

## 3. Terminology

### 3.1 Definitions of Terms Specific to This Standard:

3.1.1 The terms plate, sheet, and strip as used in this specification are defined as follows:

3.1.2 *cold rolled plate, n*—material  $\frac{3}{16}$  to  $\frac{3}{8}$  in. (4.76 to 9.52 mm), inclusive in thickness and over 10 in. (254.0 mm) in width.

3.1.3 *hot rolled plate, n*—material  $\frac{3}{16}$  in. (4.76 mm) and over in thickness and over 10 in. (254.0 mm) in width.

3.1.4 *plate, n*—material  $\frac{3}{16}$  in. (4.75 mm) and over in thickness and over 10 in. (254.0 mm) in width.

3.1.5 *sheet, n*—material under  $\frac{3}{16}$  in. (4.75 mm) in thickness and 24 in. (609.6 mm) and over in width. Material under  $\frac{3}{16}$  in. (4.75 mm) in thickness and in all widths with No. 4 finish.

3.1.6 *strip, n*—material under  $\frac{3}{16}$  in. (4.75 mm) in thickness and under 24 in. (609.6 mm) in width.

## 4. General Requirements

4.1 Material furnished under this specification shall conform to the requirements of Specification B906 unless otherwise provided herein. In the case of conflict, the requirements of this specification shall take precedence.

## 5. Materials and Manufacture

5.1 *Heat Treatment*—UNS N08020 Alloy shall be furnished in the stabilize-annealed condition.

NOTE 1—The recommended annealing temperatures are 1800 to 1850°F (982 to 1010°C) for UNS N08020.

## 6. Chemical Composition

6.1 The material shall conform to the composition limits specified in Table 1.

## 7. Mechanical Properties

7.1 *Mechanical Properties*—The material shall conform to the mechanical property requirements specified in Table 2.

## 8. Dimensions and Permissible Variations

8.1 The tolerances and permissible variations provided in Annex A1 of Specification B906 shall apply.

## 9. Keywords

9.1 N08020; plate; sheet; strip

TABLE 1 Chemical Requirements

Element	UNS N08020
Carbon, max	0.07
Manganese, max	2.00
Phosphorus, max	0.045
Sulfur, max	0.035
Silicon, max	1.00
Nickel	32.00–38.00
Chromium	19.00–21.00
Molybdenum	2.00–3.00
Copper	3.00–4.00
Columbium (Nb) + tantalum	8 × carbon–1.00
Nitrogen	...
Iron	remainder <sup>A</sup>

<sup>A</sup> By difference.

TABLE 2 Mechanical Property Requirements

Tensile Strength, min		Yield Strength, <sup>A</sup> min		Elongation <sup>B</sup> in 2 in. (50.8 mm), min, %
ksi	MPa	ksi	MPa	
80	551	35	241	30.0
Hardness Number, max <sup>C</sup>				
Brinell		Rockwell B		
217		95		

<sup>A</sup> Yield strength shall be determined by the offset method at 0.2 % limiting permanent set in accordance with Test Methods B906. An alternative method of determining yield strength may be based on a total extension under load of 0.5 %.

<sup>B</sup> Elongation for thickness, less than 0.015 in. (0.38 mm) shall be 20 % minimum, in 1 in. (25.4 mm).

<sup>C</sup> Either Brinell or Rockwell B hardness is permissible.

## SUPPLEMENTARY REQUIREMENTS

The following supplementary requirements shall be applied only when specified by the purchaser in the inquiry, contract, or order.

### S1. Corrosion Tests

S1.1 One intergranular corrosion test per lot shall be performed by the manufacturer on a sensitized specimen and tested in accordance with Practices A262. When this supplementary requirement is specified, the specific practice (Practice B or Practice E) shall also be specified. If Practice B is specified, the specimen must pass with a rate of less than 0.002 inches per month. A lot for intergranular corrosion testing shall be the same as for mechanical testing.

S1.1.1 In addition to the anneal recommended in Note 1, the specimen shall be sensitized for 1 h at 1250°F (677°C) before being subjected to corrosion testing.

S1.1.2 If any corrosion test specimen fails the test, the material represented by such specimens may be reheat-treated and resubmitted for test.

ASMENORMDOC.COM : Click to view the full PDF of ASME BPVC.II.B (ASME BPVC Section II part B) 2025

INTENTIONALLY LEFT BLANK

# SPECIFICATION FOR WELDED UNS N08020, N08024, AND N08026 ALLOY PIPE



SB-464

(Identical with ASTM Specification B464-05(2009) except that certification and reporting have been made mandatory.)

ASMENORMDOC.COM : Click to view the full PDF of ASME BPVC.II.B (ASME BPVC Section II part B) 2025

# SPECIFICATION FOR WELDED UNS N08020, N08024, AND N08026 ALLOY PIPE



SB-464

[Identical with ASTM Specification B 464-05(2009) except that certification has been made mandatory.]

## 1. Scope

**1.1** This specification covers welded UNS N08020, N08024, and N08026 alloy pipe for general corrosion-resisting and low- or high-temperature service.

**1.2** The pipe covered is nominal pipe sizes up to and including NPS 6, with the nominal wall thicknesses given as Schedules 5S, 10S, and 40S and nominal pipe sizes up to and including NPS 2, also including Schedule 80S. Table 2 of Specification B 775 is based on Table A1 of ANSI B36.19 and gives the nominal dimensions of these sizes. Table 3 of Specification B 775 lists the dimensional requirements of these sizes. Pipe having other dimensions may be furnished provided such pipe complies with all other requirements of this specification.

**1.3** The values stated in inch-pound units are to be regarded as the standard. The values given in parentheses are for information only.

**1.4** *This standard does not purport to address all of the safety concerns, if any, associated with its use. It is the responsibility of the user of this standard to become familiar with all hazards including those identified in the appropriate Material Safety Data Sheet (MSDS) for this product/material as provided by the manufacturer, to establish appropriate safety and health practices, and determine the applicability of regulatory limitations prior to use.*

## 2. Referenced Documents

### 2.1 ASTM Standards:

A 262 Practices for Detecting Susceptibility to Intergranular Attack in Austenitic Stainless Steels

B 775 Specification for General Requirements for Nickel and Nickel-Alloy Welded Pipe

B 899 Terminology Relating to Non-ferrous Metals and Alloys

### 2.2 ANSI Standard:

B36.19 Stainless Steel Pipe

## 3. Terminology

### 3.1 Definitions:

**3.1.1** Definitions for terms defined in Terminology B 899 shall apply unless otherwise defined by the requirements of this document.

## 4. General Requirement

**4.1** Material furnished in accordance with this specification shall conform to the applicable requirements of the current edition of Specification B 775 unless otherwise provided herein.

## 5. Ordering Information

**5.1** It is the responsibility of the purchaser to specify all requirements that are necessary for material ordered under this specification. Examples of such requirements include, but are not limited to, the following:

**5.1.1** Quantity (feet or number of lengths),

**5.1.2** UNS number,

**5.1.3** Size (nominal pipe size and schedule),

**5.1.4** Length (random or specific),

**5.1.5** ASTM designation,

**5.1.6** *Product Analysis* — State if required,

**5.1.7** DELETED

**5.1.8** *Purchaser Inspection* — State which tests or inspections are to be witnessed, if any, and

**5.1.9** Supplementary requirements, if any.

## 6. Materials and Manufacture

**6.1** The pipe shall be made from flat-rolled stock by an automatic welding process with no addition of filler metal.

**6.2 Heat Treatment** — Pipe of UNS N08020 alloy shall be furnished in the stabilized-annealed condition. Pipe of UNS N08024 alloy shall be furnished in the annealed condition. Pipe of UNS N08026 alloy shall be furnished in the solution-annealed condition.

NOTE 1 — The recommended annealing temperatures are 1800 to 1850°F (982 to 1010°C) for UNS N08020, 1925 to 1975°F (1052 to 1079°C) for UNS N08024, and 2050 to 2200°F (1121 to 1204°C) for UNS N08026.

## 7. Chemical Composition

**7.1** The material shall conform to the composition limits specified in Table 1. One test is required for each lot as defined in Specification B 775.

**7.2** If a product analysis is performed, it shall meet the chemistry limits prescribed in Table 1, subject to the analysis tolerances specified in Specification B 775.

## 8. Mechanical Properties and Other Requirements

**8.1 Mechanical Properties** — The material shall conform to the mechanical property requirements specified in Table 2. One test is required for each lot as defined in Specification B 775.

**8.2 Flattening Test** — A flattening test shall be made on each end of one pipe per lot. Superficial ruptures resulting from surface imperfections shall not be cause for rejection.

**8.3 Nondestructive Test Requirements** — Each pipe shall be subjected to either a pressure test or a nondestructive electric test at the manufacturer's option. The purchaser may specify which test is to be used.

**8.4 Transverse Guided Bend Test** — At the option of the pipe manufacturer, the transverse guided bend test may be substituted in lieu of the flattening test. Two bend specimens shall be taken transversely from pipe or the test specimens may be taken from a test plate of the same material and heat as pipe, which is attached to the end of

TABLE 1  
CHEMICAL REQUIREMENTS

Element	Composition, %		
	UNS N08020	UNS N08024	UNS N08026
Carbon, max	0.07	0.03	0.03
Manganese, max	2.00	1.00	1.00
Phosphorus, max	0.045	0.035	0.03
Sulfur, max	0.035	0.035	0.03
Silicon, max	1.00	0.50	0.50
Nickel	32.00–38.00	35.00–40.00	33.00–37.20
Chromium	19.00–21.00	22.50–25.00	22.00–26.00
Molybdenum	2.00–3.00	3.50–5.00	5.00–6.70
Copper	3.00–4.00	0.50–1.50	2.00–4.00
Columbium (Nb) + tantalum	8× carbon–1.00	0.15–0.35	
Nitrogen	...	...	0.10–0.16
Iron <sup>A</sup>	Remainder	Remainder	Remainder

<sup>A</sup> By difference.

TABLE 2  
MECHANICAL PROPERTY REQUIREMENTS

Tensile Strength, min, ksi (MPa)	Yield Strength, min, ksi (MPa)	Elongation in 2 in. (50.8 mm), min, %
80 (551)	35 (241)	30.0

the cylinder and welded as a prolongation of the pipe longitudinal seam. One test is required for each lot as defined in Specification B 775.

## 9. Lengths

**9.1** Lengths may be ordered as either random lengths (normally 15 to 24 ft (4.6 to 8.3 m) with some agreed upon allowance for shorts) or specific cut lengths.

## 10. Keywords

**10.1** welded pipe; N08020; N08024; N08026

## SUPPLEMENTARY REQUIREMENTS

The following supplementary requirements shall be applied only when specified by the purchaser in the inquiry, contract, or order:

### S1. Corrosion Tests

**S1.1** One intergranular corrosion test per lot shall be performed by the manufacturer on a sensitized specimen and tested in accordance with Practices A 262. When this supplementary requirement is specified, the specific practice (Practice B or Practice E) shall also be specified. If Practice B is specified, the specimen must pass with a rate of less than 0.002 in. (0.05 mm) per month. A lot for

intergranular corrosion testing shall be the same as for mechanical testing.

**S1.1.1** In addition to the anneal recommended in Note 1, the specimen shall be sensitized for 1 h at 1250°F (677°C) before being subjected to corrosion testing.

**S1.1.2** If any corrosion test specimen fails the test, the material represented by such specimens may be reheat-treated and resubmitted for test.

ASME BPVC Section II part B) 2025  
ASMENORMDOC.COM : Click to view the full PDF of ASME BPVC.II.B

# SPECIFICATION FOR SEAMLESS COPPER-NICKEL PIPE AND TUBE



**SB-466/SB-466M**

(Identical with ASTM Specification B466/B466M-18 except for the deletion of paras. 5.2.1, 9.5, and 9.5.1, and revision to para. 11.2 to make tensile testing and nondestructive testing mandatory for all sizes. Certification and test reports have been made mandatory.)

# Specification for Seamless Copper-Nickel Pipe and Tube

## 1. Scope

1.1 This specification establishes the requirements for seamless copper-nickel pipe and tube in straight lengths, suitable for general engineering purposes. The alloys involved are copper alloys UNS Nos. C70400, C70600, C70620, C71000, C71500, C71520, and C72200.

1.1.1 Copper alloys UNS Nos. C70620 and C71520 are intended for product that will be subsequently welded.

1.2 *Units*—Values stated in either SI units or inch-pound units are to be regarded separately as standard. Within the text, SI units are shown in brackets. The values stated in each system may not be exact equivalents; therefore, each system shall be used independently of the other. Combining values from the two systems may result in nonconformance with the specification.

1.3 The following safety hazard caveat pertains only to the test methods described in this specification:

1.3.1 *This standard does not purport to address all of the safety concerns, if any, associated with its use. It is the responsibility of the user of this standard to establish appropriate safety, health, and environmental practices and determine the applicability of regulatory limitations prior to use.*

1.4 *This international standard was developed in accordance with internationally recognized principles on standardization established in the Decision on Principles for the Development of International Standards, Guides and Recommendations issued by the World Trade Organization Technical Barriers to Trade (TBT) Committee.*

## 2. Referenced Documents

### 2.1 ASTM Standards:

B153 Test Method for Expansion (Pin Test) of Copper and Copper-Alloy Pipe and Tubing  
B251/B251M Specification for General Requirements for Wrought Seamless Copper and Copper-Alloy Tube  
B846 Terminology for Copper and Copper Alloys  
B968/B968M Test Method for Flattening of Copper and Copper-Alloy Pipe and Tube  
E8/E8M Test Methods for Tension Testing of Metallic Materials

E18 Test Methods for Rockwell Hardness of Metallic Materials

E54 Test Methods for Chemical Analysis of Special Brasses and Bronzes (Withdrawn 2002)

E62 Test Methods for Chemical Analysis of Copper and Copper Alloys (Photometric Methods) (Withdrawn 2010)

E75 Test Methods for Chemical Analysis of Copper-Nickel and Copper-Nickel-Zinc Alloys (Withdrawn 2010)

E76 Test Methods for Chemical Analysis of Nickel-Copper Alloys (Withdrawn 2003)

E118 Test Methods for Chemical Analysis of Copper-Chromium Alloys (Withdrawn 2010)

E243 Practice for Electromagnetic (Eddy Current) Examination of Copper and Copper-Alloy Tubes

E478 Test Methods for Chemical Analysis of Copper Alloys

### 2.2 Other Standard:

ASME Boiler and Pressure Vessel Code

## 3. General Requirements

3.1 The following sections of Specification B251/B251M constitute a part of this specification:

3.1.1 Terminology,

3.1.2 Materials and Manufacture,

3.1.3 Dimensions, Mass, and Permissible Variations,

3.1.4 Workmanship, Finish, and Appearance,

3.1.5 Sampling,

3.1.6 Number of Tests and Retests,

3.1.7 Test Specimens,

3.1.8 Test Methods,

3.1.9 Significance of Numerical Limits,

3.1.10 Inspection,

3.1.11 Rejection and Rehearing,

3.1.12 Certification,

3.1.13 Packing and Package Marking, and

3.1.14 Mill Test Report.

3.2 In addition, when a section with a title identical to that referenced in 3.1, above, appears in this specification, it contains additional requirements which supplement those appearing in Specification B251/B251M.

#### 4. Terminology

4.1 *Definitions*—For definitions of terms related to copper and copper alloys, refer to Terminology B846.

#### 5. Ordering Information

5.1 Include the following specified choices when placing orders for product under this specification, as applicable:

- 5.1.1 ASTM designation and year of issue,
- 5.1.2 Copper Alloy UNS No. (Scope section),
- 5.1.3 Temper (Temper section),
- 5.1.4 Dimensions; diameter or distance between parallel surfaces, wall thickness, or size (see also Table X1.1).
- 5.1.5 Total length, total weight, or number of pieces of each, and
- 5.1.6 Intended application.

5.2 The following options are available but may not be included unless specified at the time of placing of the order when required.

- 5.2.1 DELETED
- 5.2.2 Hydrostatic Test (Nondestructive Test Requirements section),
  - 5.2.2.1 If the product needs to be subjected to a pressure gage reading over 1000 psi [7 MPa].
- 5.2.3 Pneumatic Test (Nondestructive Test Requirements section),
- 5.2.4 Heat identification or traceability requirements, or both,
- 5.2.5 DELETED
- 5.2.6 DELETED
- 5.2.7 DELETED
- 5.2.8 When the product in alloys C71000 or C72200 is to be subsequently welded (Table 1, Footnote A), and
- 5.2.9 When product is purchased for an agency of the U.S. Government (Purchases for U.S. Government section).

#### 6. Materials and Manufacture

6.1 *Materials*—The material of manufacture shall be cast billets of copper alloys UNS Nos. C70400, C70600, C70620, C71000, C71500, C71520, and C72200 of such purity and soundness as to be suitable for processing into the products prescribed herein.

6.2 *Manufacture*—The product shall be manufactured by such hot extrusion or piercing and subsequent cold working and annealing as to produce a uniform, seamless wrought structure in the finished product.

#### 7. Chemical Composition

7.1 The material shall conform to the chemical composition requirements in Table 1 for the copper alloy UNS No. designation specified in the ordering information.

7.2 These composition limits do not preclude the presence of other elements. By agreements between the manufacturer and purchaser, limits may be established and analysis required for unnamed elements.

7.2.1 For alloys in which copper is listed as “remainder,” copper is the difference between the sum of results of all elements determined and 100 %.

7.2.2 When all elements in Table 1 are determined, the sum of results shall be as shown below:

Copper Alloy UNS No.	Copper Plus Named Elements, % min
C70400	99.5
C70600 & C70620	99.5
C71000	99.5
C71500 & C71520	99.5
C72200	99.8

#### 8. Temper

8.1 The standard tempers for products described in this specification are given in Table 2.

8.1.1 *Annealed Temper*—O60 (soft anneal).

8.1.2 *Drawn Tempers*—H55 (light drawn), H80 (hard drawn), or HE80 (hard drawn and end annealed).

NOTE 1—The H55 (light drawn) temper is used only when product of

TABLE 1 Chemical Requirements

Copper Alloy UNS Nos.	Copper incl Silver	Nickel incl Cobalt	Lead, max	Iron	Composition, %					
					Zinc, max	Manganese	Sulfur, max	Phosphorus, max	Chromium	Other Named Elements
C70400	remainder	4.8 to 6.2	0.05	1.3 to 1.7	1.0	0.30 to 0.8	0.02	0.02	...	...
C70600	remainder	9.0 to 11.0	0.05	1.0 to 1.8	1.0	1.0 max	...	...	...	...
C70620	86.5 min	9.0 to 11.0	0.02	1.0 to 1.8	0.50	1.0 max	0.02	0.02	...	Carbon 0.05 max
C71000	remainder	19.0 to 23.0	0.05 <sup>A</sup>	0.5 to 1.0	1.0 <sup>A</sup>	1.0 max	0.02	0.02	...	<sup>A</sup>
C71500	remainder	29.0 to 33.0	0.05	0.40 to 1.0	1.0	1.0 max	...	...	...	...
C71520	65.0 min	29.0 to 33.0	0.02	0.40 to 1.0	0.50	1.0 max	0.02	0.02	...	Carbon 0.05 max
C72200	remainder	15.0 to 18.0	0.05 <sup>A</sup>	0.50 to 1.0	1.0 <sup>A</sup>	1.0 max	0.02	0.02	0.30 to 0.7	<sup>A,B</sup>

<sup>A</sup> When the product is for subsequent welding applications, and so specified by the purchaser, zinc shall be 0.50 % max, lead 0.02 % max, and carbon 0.05 % max.

<sup>B</sup> Silicon 0.03 max, titanium 0.03 max.

TABLE 2 Mechanical Requirements

Temper Code	Temper Name	Copper Alloy UNS Nos.	Tensile Strength, min		Yield Strength, <sup>A</sup> min		Rockwell <sup>B</sup> Hardness 30 T
			ksi	MPa	ksi	MPa	
O60	Soft anneal <sup>C</sup>	C70400	37	255	12	85	45 max
		C70600 & C70620	38	260	13	90	45 max
		C71000	45	310	16	110	48 max
		C71500 & C71520	52	360	18	125	51 max
		C72200	40	275	14	95	45 max
H55	Light drawn	C70400	40	275	30	205	41 to 65
		C70600 & C70620	45	310	35	240	45 to 70
		C72200	48	330	42	290	55 to 70
H80	Hard drawn	C70400	45	310	35	240	60 min
		C70600 & C70620	50	345	40	275	63 min
		C71000	55	380	43	295	67 min
		C71500 & C71520	70	485	45	310	70 min
		C72200	55	380	44	305	67 min

<sup>A</sup> At 0.5 % extension under load.

<sup>B</sup> Rockwell hardness values shall apply only to tube or pipe having a wall thickness of 0.020 in. [0.5 mm] or over and an outside diameter of  $\frac{9}{16}$  in. [8 mm] or over. For all other tube no Rockwell hardness values shall apply. Rockwell hardness tests shall be made on the inside surface of the tube. When suitable equipment is not available for determining the specified Rockwell hardness, other Rockwell scales and values may be specified subject to agreement between the manufacturer and the purchaser.

<sup>C</sup> Although no minimum grain size is specified, the product must nevertheless have fully recrystallized grain structure.

some stiffness yet capable of being bent is needed. The H80 (hard drawn) temper is used only when there is a need for material as strong as commercially feasible.

## 9. Mechanical Property Requirements

9.1 *Tensile Strength Requirements*—Product furnished under this specification shall conform to the tensile and yield strength requirements prescribed in Table 2 when tested in accordance with Test Methods E8/E8M.

9.2 *Rockwell Hardness Requirements*—Product furnished under this specification shall conform to the Rockwell hardness requirements prescribed in Table 2 when tested in accordance with Test Methods E18.

9.3 The mechanical property requirements for tubes of all alloys in the H80 temper are only applicable to the following sizes:

Outside Diameter, in. [mm]	Wall Thickness, in. [mm]
Up to 1 [25] incl	0.020-0.120 [0.5-3.0] incl
Over 1-2 [25-50] incl	0.035-0.180 [0.9-4.5] incl
Over 2-4 [50-100] incl	0.060-0.250 [1.5-6.5] incl

9.3.1 For other sizes in the H80 (hard drawn) temper, the mechanical property requirements shall be established by agreement between the manufacturer and the purchaser.

9.4 The mechanical property requirements for tubes of the HE80 (hard drawn and end annealed) temper shall be established by agreement between the manufacturer or supplier and the purchaser.

9.5 DELETED

9.5.1 DELETED

## 10. Performance Requirements

10.1 *Expansion Test Requirements*:

10.1.1 Tube furnished in the O60 (soft anneal) temper and the HE80 (hard drawn and end annealed) shall withstand an expansion to 30 % of the outside diameter when tested in accordance with Test Method B153.

10.1.1.1 The expanded sample shall show no cracking or other defect visible to the unaided eye.

10.1.1.2 The expansion test is not required for tube furnished in tempers other than O60 and HE80.

10.2 *Flattening Test Alternative*:

10.2.1 As an alternate to the expansion test for product over 4 in. [100 mm] in diameter, the flattening test described in Test Method B968/B968M may be performed.

10.2.2 During inspection, the flattened areas of the test specimen shall be free of defects, but blemishes of a nature that do not interfere with the intended application are acceptable.

## 11. Other Requirements

11.1 *Purchases for U.S. Government Agencies*—If the product ordered is for an agency of the U.S. Government, when specified in the contract or purchase order, the product furnished shall conform to the conditions specified in the Supplementary Requirements section of Specification B251/B251M.

11.2 *Nondestructive Test Requirements*:

Each pipe or tube shall be subjected to either the hydrostatic test or the eddy current test. The type of test to be used shall be at the option of the manufacturer, unless otherwise specified in the purchase order.

11.2.1 *Electromagnetic (Eddy Current) Test*: Each tube up to and including 3.125-in. [80-mm] nominal outside diameter shall be subjected to an eddy current test. Testing shall follow the procedures of Practice E243 and the Test Methods section of this specification.

11.2.1.1 The provisions for the determination of “end-effect” in Practice E243 shall not apply.

11.2.1.2 The tested tubes, which do not actuate the signaling device of the testing unit, shall be considered as conforming to the requirements of the test.

11.2.1.3 Either notch depth or drilled hole standards shall be used

11.2.1.4 Notch depth standards shall be 22 % of the wall thickness.

11.2.1.5 The sizes of drilled hole standards shall in accordance with Table X1.2 of Practice E243.

11.2.1.6 *Hydrostatic Test Alternative*—As an alternative to the eddy current test for tubes of diameters above 1.25 in. [32 mm], the manufacturer shall have the option to perform the hydrostatic test to the method in the Test Methods section.

11.2.2 *Hydrostatic Test*—When specified in the contract or purchase order, or as an alternate to the eddy current test for tubes above 1.25 in. [32 mm] in diameter (see 11.2.1.6), each tube shall stand, without showing evidence of leakage, an internal hydrostatic pressure sufficient to produce a fiber stress of 7000 psi [48 MPa] as determined by the following equation for thin hollow cylinders under tension:

$$P = 2St/(D - 0.8t) \quad (1)$$

where:

- $P$  = hydrostatic pressure, psi [MPa];  
 $t$  = wall thickness of the material, in. [mm];  
 $D$  = outside diameter of the material, in. [mm]; and  
 $S$  = allowable stress of the material, psi [MPa].

11.2.2.1 The tube need not be subjected to a pressure gage reading over 1000 psi [7 MPa] unless specifically stipulated in the contract or purchase order.

11.2.2.2 When the hydrostatic test is specified for tubes of less than 0.50 in. [12 mm] in outside diameter and less than 0.060 in. [1.5 mm] in wall thickness, the manufacturer shall have the option to perform either the hydrostatic test or the pneumatic test to the requirements specified in Section 14.

11.2.3 *Pneumatic Test*—When specified in the contract or purchase order, each tube shall be subjected to a minimum internal air pressure of 60 psig [415 kPa] for 5 s without showing evidence of leakage.

## 12. Dimensions, Mass, and Permissible Variations

12.1 *Wall Thickness Tolerances*—The wall thickness tolerances shall be in accordance with Table 3.

12.2 *Diameter Tolerances*—The diameter tolerances shall be in accordance with Table 4.

12.3 Tolerance on distances between parallel surfaces for tubes other than round shall be as agreed between the manufacturer or supplier and purchaser.

12.4 The following tolerances shall be as specified in Specification B251/B251M with particular reference to the following tables and related paragraphs:

12.4.1 *Length Tolerances and Schedule of Tube Lengths*—Section 5.5 and Tables 5 and 6.

12.4.2 *Roundness*—Section 5.4.

12.4.3 *Squareness of Cut*—Section 5.6.

12.4.4 *Straightness Tolerances*—Section 5.7.1 and Table 7.

## 13. Specimen Preparation

13.1 *Chemical Analysis*—Analytical specimen preparation shall be the responsibility of the reporting laboratory.

13.2 *Flattening Test*—Test specimens shall be according to Test Method B968/B968M. When the temper is other than annealed, the sample may be annealed prior to testing.

## 14. Test Methods

### 14.1 Chemical Analysis:

14.1.1 In cases of disagreement, test methods for chemical analysis shall be subject to agreement between the manufacturer or supplier and the purchaser. The following table is a list of published test methods, some of which are considered by ASTM as no longer viable. These and others not listed may be used subject to agreement.

TABLE 3 Wall Thickness Tolerances

NOTE 1—*Maximum Deviation of Any Point*—The following tolerances are plus and minus; if tolerances all plus or all minus are desired, double the values given.

Wall Thickness, in. [mm]	Outside Diameter, <sup>A</sup> in. [mm]						
	1/32 to 1/8	Over 1/8 to 3/8	Over 3/8 to 1	Over 1 to 2	Over 2 to 4	Over 4 to 7	Over 7 to 10
	[0.80 to 3.2] incl	[3.2 to 16], incl	[16 to 25], incl	[25 to 50] incl	[50 to 150] incl	[100 to 200] incl	[200 to 250], incl
Up to 0.017 [40] incl	0.0025 [0.064]	0.0015 [0.38]	0.002 [0.057]	0.0025 [0.064]	...	...	...
Over 0.017 to 0.024 [0.040 to 0.60] incl	0.004 [0.10]	0.0025 [0.064]	0.0025 [0.064]	0.003 [0.076]	...	...	...
Over 0.024 to 0.034 [0.60 to 0.90] incl	0.004 [0.10]	0.003 [0.076]	0.003 [0.076]	0.004 [0.10]	0.005 [0.013]	...	...
Over 0.034 to 0.057 [0.90 to 1.4] incl	0.004 [0.10]	0.004 [0.10]	0.0045 [0.11]	0.0045 [0.11]	0.0065 [0.17]	0.009 [0.23]	...
Over 0.057 to 0.082 [1.4 to 2.1] incl	...	0.0045 [0.11]	0.005 [0.13]	0.005 [0.13]	0.0075 [0.19]	0.010 [0.25]	0.013 [0.33]
Over 0.082 to 0.119 [2.1 to 3.0] incl	...	0.005 [0.13]	0.0065 [0.17]	0.0065 [0.17]	0.009 [0.23]	0.011 [0.28]	0.014 [0.36]
Over 0.119 to 0.164 [3.0 to 4.2] incl	...	0.007 [0.18]	0.007 [0.18]	0.0075 [0.19]	0.010 [0.25]	0.013 [0.33]	0.015 [0.38]
Over 0.164 to 0.219 [4.2 to 5.5] incl	...	...	0.009 [0.23]	0.010 [0.25]	0.012 [0.30]	0.015 [0.38]	0.018 [0.46]
Over 0.219 to 0.283 [5.5 to 7.2] incl	...	...	0.012 [0.30]	0.013 [0.33]	0.015 [0.38]	0.018 [0.46]	0.020 [0.51]
Over 0.283 to 0.379 [7.2 to 9.6] incl	...	...	...	0.15 [0.38]	0.018 [0.46]	0.020 [0.51]	0.023 [0.58]
Over 0.379 [9.6]	...	...	...	6 <sup>B</sup>	6 <sup>B</sup>	8 <sup>B</sup>	8 <sup>B</sup>

<sup>A</sup> When tube is ordered by outside and inside diameters, the maximum plus and minus deviation of the wall thickness from the nominal at any point shall not exceed the values given in this table by more than 50 %.

<sup>B</sup> Percent of the specified wall thickness expressed to the nearest 0.001 in. [0.025 mm].

TABLE 4 Average Diameter<sup>A</sup> Tolerances

Specified Diameter		Tolerance Applies to	Tolerances, plus and minus, <sup>B</sup> in.	Tolerances, plus and minus, <sup>B</sup>
in.	mm		for Tubes of Copper Alloy UNS Nos. C70400, C70600, C70620, C71000, C71500, C71520, and C72200	mm for Tubes of Copper Alloy UNS Nos. C70400, C70600, C70620, C71000, C71500, C71520, and C72200
Up to 1/8, incl	Up to 3.2, incl	inside diameter	0.003	0.076
Up to 1/8, incl	Up to 3.2, incl	outside diameter	0.0025	0.064
Over 1/8 to 3/8, incl	Over 3.2 to 16, incl	inside or outside	0.0025	0.064
Over 3/8 to 1, incl	Over 16 to 25, incl	inside or outside	0.003	0.076
Over 1 to 2, incl	Over 25 to 50, incl	inside or outside	0.004	0.10
Over 2 to 3, incl	Over 50 to 75, incl	inside or outside	0.005	0.13
Over 3 to 4, incl	Over 75 to 100, incl	inside or outside	0.006	0.15
Over 4 to 5, incl	Over 100 to 125, incl	inside or outside	0.008	0.20
Over 5 to 6, incl	Over 125 to 150, incl	inside or outside	0.009	0.23
Over 6 to 8, incl	Over 150 to 200, incl	inside or outside	0.010	0.25
Over 8 to 10, incl	Over 200 to 250, incl	inside or outside	0.013	0.33

<sup>A</sup> The average outside or inside diameter of a tube is the average of the maximum and minimum outside diameters, or of the maximum and minimum inside diameters, whichever is applicable, as determined at any one cross section of the tube.

<sup>B</sup> If tolerances all plus or all minus are desired, double the values given.

Element	Test Method
Carbon	E76
Chromium	E118
Copper	E478
Iron	E54
Lead	E478; atomic absorption
Manganese	E75
Nickel	E478; gravimetric
Phosphorus	E62
Silicon	E54
Sulfur	E76
Zinc	E478; atomic absorption

14.1.2 Test methods for the determination of element(s) required by contractual or purchase order agreement shall be as agreed upon by the manufacturer or supplier and the purchaser.

14.2 Other Tests:

14.2.1 Tensile Strength—Tensile strength shall be determined in accordance with Test Methods E8/E8M.

14.2.1.1 Whenever test results are obtained from both full-size and machined specimens and they differ, the test results from the full-size specimens shall prevail.

14.2.2 Flattening Test—Each test specimen shall be flattened according to Test Method B968/B968M.

14.2.3 Electromagnetic (Eddy Current) Test—Testing shall follow the procedures in Practice E243, except for the determination of “end-effect.”

14.2.3.1 Notch-depth standards shall be rounded to the nearest 0.001 in. [0.025 mm]. The notch depth tolerance shall be ±0.0005 in. [0.013 mm].

14.2.3.2 Drilled hole standards shall be rounded to the nearest 0.001 in. (0.025 mm). The drilled hole tolerance shall be ±0.0005 in. [0.013 mm].

14.2.3.3 Alternatively, at the option of the manufacturer, using speed-insensitive eddy current testing units that are

equipped so that a percentage of the maximum imbalance signal can be selected, a maximum imbalance signal of 0.3 % shall be used.

14.2.3.4 Tubes that do not activate the signaling device of the eddy current tested shall be considered as conforming to the requirements of this test. Tubes with discontinuities indicated by the testing unit are permitted, at the option of the manufacturer, to be reexamined or retested to determine whether the discontinuity is cause for rejection. Signals that are found to have been caused by minor mechanical damage, soil, or moisture shall not be cause for rejection of the tubes provided the tube dimensions are still within prescribed limits and the tune is suitable for its intended application.

14.2.4 Hydrostatic Test—The test method used shall permit easy visual detection of any leakage or by pressure differential. Any evidence of leakage shall be cause for rejection.

14.2.5 Pneumatic Test—The test method used shall permit easy visual detection of any leakage or by pressure differential. Any evidence of leakage shall be cause for rejection.

15. Certification

15.1 The test report and certification requirements of Specification B251/B251M are mandatory.

16. Keywords

16.1 copper-nickel; pipe; seamless; tube; UNS No. C70400; UNS No. C70600; UNS No. C70620; UNS No. C71000; UNS No. C71500; UNS No. C71520; UNS No. C72200

## APPENDIX

## (Nonmandatory Information)

## X1. PREFERRED SIZES

X1.1 It is recommended that wherever possible, product purchased to this specification be ordered to the diameters and wall thicknesses indicated in Table X1.1.

TABLE X1.1 Preferred Wall Thicknesses for Drawn Seamless Pipe Based on SPS Diameter

SPS	Outside Diameter, in. [mm]	Wall Thickness						
		Specials			Regular, in. [mm]	Extra Strong, in. [mm]		
		in. [mm]	in. [mm]	in. [mm]				
1/8	0.405 [10.3]	0.058 [1.47]	...	...	...	...	0.062 [1.57]	0.100 [2.54]
1/4	0.540 [13.7]	0.065 [1.65]	0.072 [1.83]	...	...	...	0.082 [2.08]	0.123 [3.12]
3/8	0.675 [17.1]	0.065 [1.65]	0.072 [1.83]	0.095 [2.41]	0.148 [3.76]	...	0.090 [2.29]	0.127 [3.23]
1/2	0.840 [21.3]	0.065 [1.65]	0.072 [1.83]	0.120 [3.03]	0.203 [5.16]	...	0.107 [2.72]	0.149 [3.78]
3/4	1.050 [26.7]	0.065 [1.65]	0.083 [2.11]	0.148 [3.76]	0.238 [6.05]	...	0.114 [2.90]	0.157 [3.99]
1	1.315 [33.4]	0.065 [1.65]	0.095 [2.41]	0.203 [5.16]	0.340 [8.64]	...	0.126 [3.20]	0.182 [4.62]
1 1/4	1.660 [42.2]	0.072 [1.83]	0.095 [2.41]	0.120 [3.03]	0.220 [5.59]	0.380 [9.65]	0.146 [3.71]	0.194 [4.93]
1 1/2	1.900 [48.3]	0.072 [1.83]	0.109 [2.77]	0.134 [3.40]	0.250 [6.35]	0.425 [10.8]	0.150 [3.81]	0.203 [5.16]
2	2.375 [60.3]	0.083 [2.11]	0.120 [3.03]	0.165 [4.19]	0.340 [8.64]	0.520 [13.2]	0.156 [3.96]	0.221 [5.61]
2 1/2	2.875 [73.0]	0.083 [2.11]	0.134 [3.40]	0.203 [5.16]	0.380 [9.65]	...	0.187 [4.75]	0.280 [7.11]
3	3.500 [88.9]	0.095 [2.41]	0.165 [4.19]	0.250 [6.35]	0.458 [11.6]	...	0.219 [5.56]	0.304 [7.72]
3 1/2	4.000 [102]	0.095 [2.41]	0.180 [4.57]	0.284 [7.21]	...	...	0.250 [6.35]	0.321 [8.15]
4	4.500 [114]	0.109 [2.77]	0.203 [5.16]	0.340 [8.64]	...	...	0.250 [6.35]	0.341 [8.66]
5	5.552 [141]	0.125 [3.18]	0.220 [5.59]	0.425 [10.8]	...	...	0.250 [6.35]	0.375 [9.52]
6	6.625 [168]	0.134 [3.40]	0.259 [6.58]	0.457 [11.6]	...	...	0.250 [6.35]	0.437 [11.1]

ASMENORMDOC.COM : Click to view the full PDF of ASME BPVC.II.B (ASME BPVC Section II part B) 2025

INTENTIONALLY LEFT BLANK

## SPECIFICATION FOR WELDED COPPER-NICKEL PIPE



SB-467



(25)

(Identical with ASTM Specification B467-14(2022) except that the use of filler metal is prohibited, and para. 16.2.1 revised. Certification, test report, and product specification marking have been made mandatory..)

*ASME SB-467 replaces paras. 5.2.2, 5.2.3, 5.2.7, 6.4.1, 16.2.1, 21.1, 21.2, 22.1, and 23.2 of ASTM B467 with the following:*

5.2.2 DELETED

5.2.3 DELETED

5.2.7 DELETED

6.4.1 Welded copper-nickel pipe shall be produced by a welding technique that does not require filler metal. Specifically, welding shall be accomplished using electric or high frequency resistance or other appropriate techniques that do not require filler metal.

16.2.1 Tension test specimens shall be of the full section of the pipe and shall conform to the requirements of Test Specimens section of Test Methods E8/E8M, unless the limitations of the testing machine preclude the use of such a specimen. Test specimens conforming to Fig. 13, Tension Test Specimen for Large-Diameter Tubular Products, of Test Methods E8/E8M may be used when a full-section specimen cannot be tested.

21.1 The manufacturer shall furnish to the purchaser a certificate stating that each lot has been sampled, tested, and inspected in accordance with this specification and has met the requirements.

21.2 DELETED

22.1 A report of test results shall be furnished.

23.2 Each shipping unit shall be legibly marked with the purchase order number, metal or alloy designation, temper, size, shape, total length or piece count, or both, and name of supplier. The specification number shall be shown.



Designation: B467 – 14 (Reapproved 2022)

## Standard Specification for Welded Copper-Nickel Pipe<sup>1</sup>

This standard is issued under the fixed designation B467; the number immediately following the designation indicates the year of original adoption or, in the case of revision, the year of last revision. A number in parentheses indicates the year of last reapproval. A superscript epsilon ( $\epsilon$ ) indicates an editorial change since the last revision or reapproval.

### 1. Scope\*

1.1 This specification establishes the requirements for welded copper-nickel alloy pipe for general engineering purposes. The following alloys are covered:<sup>2</sup>

Copper Alloy UNS No. <sup>2</sup>	Type of Metal
C70600	90-10 copper-nickel
C70620	90-10 copper-nickel (Modified for Welding)
C71500	70-30 copper-nickel
C71520	70-30 copper-nickel (Modified for Welding)

1.2 *Units*—The values stated in inch-pound units are to be regarded as standard. The values given in parentheses are mathematical conversions to SI units that are provided for information only and are not considered standard.

1.3 *This international standard was developed in accordance with internationally recognized principles on standardization established in the Decision on Principles for the Development of International Standards, Guides and Recommendations issued by the World Trade Organization Technical Barriers to Trade (TBT) Committee.*

### 2. Referenced Documents

#### 2.1 ASTM Standards:<sup>3</sup>

B153 Test Method for Expansion (Pin Test) of Copper and Copper-Alloy Pipe and Tubing  
B601 Classification for Temper Designations for Copper and Copper Alloys—Wrought and Cast  
B846 Terminology for Copper and Copper Alloys  
B950 Guide for Editorial Procedures and Form of Product

<sup>1</sup> This specification is under the jurisdiction of ASTM Committee B05 on Copper and Copper Alloys and is the direct responsibility of Subcommittee B05.04 on Pipe and Tube.

Current edition approved May 1, 2022. Published June 2022. Originally approved in 1986. Last previous edition approved in 2014 as B467 – 14. DOI: 10.1520/B0467-14R22.

<sup>2</sup> The UNS system for copper and copper alloys is a simple expansion of the former standard designation system accomplished by the addition of a prefix “C” and a suffix “00.” The suffix can be used to accommodate composition variations of the base alloy.

<sup>3</sup> For referenced ASTM standards, visit the ASTM website, [www.astm.org](http://www.astm.org), or contact ASTM Customer Service at [service@astm.org](mailto:service@astm.org). For *Annual Book of ASTM Standards* volume information, refer to the standard’s Document Summary page on the ASTM website.

Specifications for Copper and Copper Alloys  
B968/B968M Test Method for Flattening of Copper and Copper-Alloy Pipe and Tube  
E8/E8M Test Methods for Tension Testing of Metallic Materials  
E29 Practice for Using Significant Digits in Test Data to Determine Conformance with Specifications  
E54 Test Methods for Chemical Analysis of Special Brasses and Bronzes (Withdrawn 2002)<sup>4</sup>  
E62 Test Methods for Chemical Analysis of Copper and Copper Alloys (Photometric Methods) (Withdrawn 2010)<sup>4</sup>  
E243 Practice for Electromagnetic (Eddy Current) Examination of Copper and Copper-Alloy Tubes  
E255 Practice for Sampling Copper and Copper Alloys for the Determination of Chemical Composition  
E478 Test Methods for Chemical Analysis of Copper Alloys

#### 2.2 ASME Code:<sup>5</sup>

ASME Boiler and Pressure Vessel Code Application

#### 2.3 AWS Standards:<sup>6</sup>

A5.6/A5.6M Specification for Copper and Copper - Alloy Electrodes for Shielded Metal Arc Welding  
A5.7/A5.7M Specification for Copper and Copper - Alloy Bare Welding Rods and Electrodes

### 3. Terminology

3.1 For the definitions of terms related to copper and copper alloys, refer to Terminology B846.

### 4. Types of Welded Pipe

4.1 *As-Welded*—Pipe that has been welded with no further work performed other than straightening or cutting to length, or both.

4.2 *Welded and Annealed*—Welded pipe that has been annealed to produce a uniform grain size appropriate to the specified annealed temper.

<sup>4</sup> The last approved version of this historical standard is referenced on [www.astm.org](http://www.astm.org).

<sup>5</sup> Available from American Society of Mechanical Engineers (ASME), ASME International Headquarters, Three Park Ave., New York, NY 10016-5990, <http://www.asme.org>.

<sup>6</sup> Available from American Welding Society (AWS), 8669 NW 36<sup>th</sup> Street, #130, Miami, FL 33166, <http://www.aws.org>.

\*A Summary of Changes section appears at the end of this standard

4.3 *Welded and Cold Drawn*—Welded pipe with internal flash removed by scarfing, and subsequently cold drawn to conform to the specified temper.

4.4 *Fully Finished*—Welded pipe with internal and external flash removed by scarfing and the pipe or tube subsequently cold drawn over a mandrel and annealed as necessary to conform to the specified temper.

## 5. Ordering Information

5.1 Include the following specified choices when placing orders for product under this specification, as applicable.

- 5.1.1 ASTM designation and year of issue,
- 5.1.2 Copper Alloy UNS No. (Section 1 and Table 1),
- 5.1.3 Temper (Section 8),
- 5.1.4 Dimensions: diameter and wall thickness (12.2 and 12.3),
- 5.1.5 Lengths: whether specific or stock (12.4),
- 5.1.6 Quantity of each size,
- 5.1.7 If the product is to be subsequently welded,
- 5.1.8 Packaging and Package Marking (Section 23), and
- 5.1.9 Intended application.

5.2 The following options are available but may not be included unless specified at the time of placing the order when required.

- 5.2.1 Heat identification or traceability requirements, or both (see 14.2.1.4).
- 5.2.2 Certifications (see Section 21).
- 5.2.3 Test report (see Section 22).
- 5.2.4 Radiographic examination: whether or not required (see Section 11),
- 5.2.5 Source inspection: whether or not required (19.2),
- 5.2.6 Hydrostatic test (see 11.3),
- 5.2.7 When product is ordered for *ASME Boiler and Pressure Vessel Code Application*,
- 5.2.8 Type of *flash* to be furnished (6.3),
- 5.2.9 Pneumatic Test (see 11.3.2).

## 6. Materials and Manufacture

### 6.1 Material:

6.1.1 The material of manufacture shall be strip of one of the Copper Alloy UNS Nos. listed in 1.1 of such purity and soundness as to be suitable for processing into the products prescribed herein.

6.1.2 In the event heat identification or traceability is required, the purchaser shall specify the details desired.

### 6.2 Manufacture:

6.2.1 The product shall be manufactured by forming the material into a tubular shape and welded on a suitable forming mill.

### 6.3 Flash:

6.3.1 If the pipe is made by the high-frequency welding process, the external flash shall always be removed. The internal flash shall be treated as one of the following:

- 6.3.1.1 *IFI*—Internal flash to remain in the “as-welded” condition,
  - 6.3.1.2 *IFR*—Internal flash to be removed by scarfing, or
  - 6.3.1.3 *IFD*—Internal flash to be displaced.
- 6.3.2 Unless otherwise specified, the *IFI* condition will be furnished.

### 6.4 Filler Material:

6.4.1 Filler material, if used in the welding process, shall conform to Classification ECU<sub>Ni</sub> of AWS Specification A5.6/A5.6M or RCu<sub>Ni</sub> of AWS Specification A5.7/A5.7M.

## 7. Chemical Composition

7.1 The material shall conform to the chemical requirements specified in Table 1.

7.2 These specification limits do not preclude the presence of other elements. Limits for unnamed elements may be established by agreement between manufacturer or supplier and purchaser.

7.2.1 For copper alloys in which copper is specified as the remainder, copper may be taken as the difference between the sum of all the elements analyzed and 100 %.

7.2.1.1 When all the elements in Table 1 are analyzed, their sum shall be 99.5 % minimum.

## 8. Temper

8.1 Tempers, as defined in Classification B601 and this specification, are as follows:

8.1.1 The pipe shall be supplied in any one of the following tempers as specified and shall meet the mechanical requirements of Table 2, Table 3, or Table 4:

8.1.1.1 As welded from annealed sheet, strip, or plate (WM50),

8.1.1.2 As welded from cold-worked sheet, strip, or plate (WM00, WM01, WM02, etc.).

8.1.1.3 Welded and light annealed (WO50),

TABLE 1 Chemical Requirements

Element	Composition, %							
	Copper or Copper Alloy by UNS No	Copper (incl silver)	Nickel (incl Cobalt)	Lead, max	Iron	Zinc, max	Manganese	Other Named Alloys
C70600 <sup>A</sup>	Remainder		9.0–11.0	0.05	1.0–1.8	1.0	1.0	
C70620 <sup>A</sup>	86.5 min		9.0–11.0	.02	1.0–1.8	.50	1.0	C .05 max P .02 max S .02 max
C71500 <sup>A</sup>	Remainder		29.0–33.0	0.05	.40–1.0	1.0	1.0	
C71520 <sup>A</sup>	65.0 min		29.0–33.0	.02	.40–1.0	.50	1.0	C .05 max P .02 max S .02 max

<sup>A</sup> Cu + Sum of Named Elements, 99.5 % min.

**TABLE 2 Mechanical Requirements of As-Welded and Fully Finished Pipe When Furnished in the Annealed Temper (WO61)**

Copper Alloy UNS No.	Outside Diameter, in. (mm)	Tensile Strength, min, ksi <sup>A</sup> (MPa) <sup>B</sup>	Yield Strength at 0.5 % Extension Under Load, min, ksi <sup>A</sup> (MPa) <sup>B</sup>	Elongation in 2 in. (50.8 mm), min, %
C70600	up to 4½ (114), incl	40 (275)	15 (105)	25.0
	over 4½ (114)	38 (260)	13 (90)	25.0
C70620	up to 4½ (114), incl	40 (275)	15 (105)	25.0
	over 4½ (114)	38 (260)	13 (90)	25.0
C71500	up to 4½ (114), incl	50 (345)	20 (140)	30.0
	over 4½ (114)	45 (310)	15 (105)	30.0
C71520	up to 4½ (114), incl	50 (345)	20 (140)	30.0
	over 4½ (114)	45 (310)	15 (105)	30.0

<sup>A</sup> ksi = 1000 psi.<sup>B</sup> See Appendix X2.**TABLE 3 Mechanical Requirements of Welded and Cold-Drawn and Fully Finished Pipe in Drawn Tempers**

Copper Alloy UNS No.	Outside Diameter, in. (mm)	Tensile Strength, min, ksi <sup>A</sup> (MPa) <sup>B</sup>	Yield Strength at 0.5 % Extension Under Load, min, ksi <sup>A</sup> (MPa) <sup>B</sup>	Elongation in 2 in. (50.8 mm), min, %
C71500	up to 2 (50.8), incl, for wall thicknesses up to 0.048 (1.21 mm), incl.	72 (495)	50 (345)	12.0
	for wall thicknesses over 0.048 in. (1.21 mm)	72 (495)	50 (345)	15.0
C71520	up to 2 (50.8), incl, for wall thicknesses up to 0.048 (1.21 mm), incl.	72 (495)	50 (345)	12.0
	for wall thicknesses over 0.048 in. (1.21 mm)	72 (495)	50 (345)	15.0

<sup>A</sup> ksi = 1000 psi.<sup>B</sup> See Appendix X2.**TABLE 4 Mechanical Requirements of As-Welded Pipe**

Copper Alloy UNS No.	Condition	Outside Diameter, in. (mm)	Tensile Strength, min, ksi (MPa)	Yield Strength at 0.5 % Extension Under Load, min, ksi (MPa)
C70600	welded from annealed strip	up to 4½ (114), incl	45 (310)	30 (205)
	welded from cold-rolled strip	up to 4½ (114), incl	54 (375)	45 (310)
C70620	welded from annealed strip	up to 4½ (114), incl	45 (310)	30 (205)
	welded from cold-rolled strip	up to 4½ (114), incl	54 (375)	45 (310)

8.1.1.4 Welded and cold drawn in either light drawn, eight hard (Copper Alloy UNS No. C70600 and C70620 only) or hard drawn and stress relieved (WR00), (WR04), or

8.1.1.5 Fully finished welded and annealed (WO61).

## 9. Mechanical Property Requirements

### 9.1 Tensile Strength Requirements:

9.1.1 Product furnished under this specification shall conform to the tensile and yield strength requirements prescribed

in Table 2, Table 3, or Table 4 when tested in accordance with Test Methods E8/E8M.

## 10. Performance Requirements

### 10.1 Expansion Test Requirements:

10.1.1 The annealed pipe shall be capable of (see 8.1.1.1 and 8.1.1.3) being expanded in accordance with Test Method B153 to 30 % of its outside diameter. Pipe supplied in the “as welded” condition shall be expanded to 20 % of its outside diameter.

10.1.2 The annealed ends of pipe furnished end annealed shall be capable of being expanded 30 % of its outside diameter in accordance with Test Method B153.

10.1.3 The expanded tube area shall be free of defects, but blemishes of a nature that do not interfere with the intended application are acceptable.

10.1.4 Pipe furnished in other tempers is not subject to this test

### 10.2 Flattening Test Alternative:

10.2.1 As an alternative to the expansion test for product over 4 in. (102 mm) in diameter, the flattening test described in the Test Method section in Test Method B968/B968M may be performed.

## 11. Nondestructive Tests for Pipe

11.1 *Radiographic Examination*—Radiographic examination of the welds shall be as agreed upon.

11.2 *Eddy-Current Test*—Each pipe of nominal outside diameter within the capabilities of the eddy-current tester shall be subjected to an eddy-current test. Testing shall follow the procedures of Practice E243. The pipe shall be passed through an eddy-current testing unit adjusted to provide information on the suitability of the material for the intended application.

11.2.1 Notch depth standards rounded to the nearest 0.001 in. (0.025 mm) shall be 22 % of the nominal wall thickness. The notch depth tolerance shall be ±0.0005 in. (0.013 mm).

11.2.1.1 Pipe that does not actuate the signaling device of the eddy-current tester shall be considered as conforming to the requirements of this test. Pipe with discontinuities indicated by the testing unit may be reexamined or retested, at the option of the manufacturer, to determine whether the discontinuity is cause for rejection. Signals that are found to have been caused by minor mechanical damage, soil, or moisture, shall not be cause for rejection of the pipe, provided the dimensions are still within prescribed limits and the pipe is suitable for its intended application.

11.2.2 As an alternate to the Eddy Current test, the manufacturer shall have the option to perform a Hydrostatic Test (11.3.1).

11.3 *Hydrostatic Test Alternative*—As an alternative to the eddy current test for tubes above 2.000 in. (50.8 mm), the manufacturer shall have the option to perform the hydrostatic test to the tests described in 11.3.1 and 11.3.2.

11.3.1 *Hydrostatic Test*—When specified, the pipe shall withstand, without showing weakness or defects, an internal hydrostatic pressure sufficient to subject the material to a fiber stress of 7000 psi (48 MPa), determined by the following equation for thin hollow cylinders under tension. The pipe need

not be tested at a hydrostatic pressure of over 1000 psig (7 MPa), unless so specified.

$$P = 2St/(D - 0.8t) \quad (1)$$

where:

- $P$  = hydrostatic pressure, psig (or MPa),  
 $t$  = wall thickness of the pipe, in. (or mm),  
 $D$  = outside diameter of the pipe, in. (or mm), and  
 $S$  = allowable stress of the material.

11.3.2 *Pneumatic Test*—When specified, the pipe shall be subjected to an internal air pressure of 60 psig (400 kPa) minimum for 5 s without showing evidence of leakage. The test method used shall permit easy visual detection of any leakage, such as by having the pipe under water or by the pressure-differential method. Any evidence of leakage shall be cause for rejection.

## 12. Dimensions, Mass, and Permissible Variations

12.1 For purposes of determining conformance with the dimensional requirements prescribed in this specification, any measured value outside the specified limiting values for any dimension may be cause for rejection.

NOTE 1—Blank spaces in the tolerance tables indicate that the material is not generally available or that no tolerance has been established (see Appendix X1).

### 12.2 Outside Diameter Tolerances:

12.2.1 The outside diameter for pipe furnished “as-welded,” “as-welded and drawn,” and “as-welded fully finished” shall conform to the tolerances in Table 5 except as noted in 12.2.2.

12.2.2 These outside diameter tolerances shall not apply to the “as-welded” pipe when measured across that portion which contains the weld zone.

### 12.3 Wall Thickness Tolerances:

12.3.1 The wall thickness of pipe furnished in drawn tempers or as fully finished shall conform to the tolerances shown in Table 6, except as noted in 12.3.2 and 12.3.3.

12.3.2 The tolerances of Table 6 shall not apply to that portion of the “as-welded” wall which contains the weld flash or bead.

12.3.3 The tolerances of Table 6 shall be increased by 100 % for that portion of the “as-welded” wall which contains the weld zone.

### 12.4 Lengths and Tolerances:

12.4.1 Pipe in straight lengths shall be furnished in stock lengths with ends included unless the order requires specific lengths or specific lengths with ends.

12.4.2 The tolerances for pipe furnished in straight lengths shall be as shown in Table 7.

12.4.3 The schedule for pipe furnished with specific or stock lengths with ends shall be in accordance with Table 8.

12.5 *Squareness of Cut*—The departure from squareness of the end of any pipe shall not exceed 0.016 in./in. (0.406 mm/mm) of diameter.

12.6 *Roundness*—The difference between the major and minor diameter of pipe as determined at any one cross section shall not exceed 3 % of the nominal outside diameter.

## 13. Workmanship, Finish, and Appearance

13.1 Roundness, straightness, uniformity of the wall thickness, and inner and outer surface of the tube shall be such as to make it suitable for the intended application. Unless otherwise specified on the purchase order, the cut ends of the tubes shall be deburred by use of a rotating wire wheel or other suitable tool.

13.2 The product shall be clean and free from defects, but blemishes of a nature that do not interfere with the intended application are acceptable. Annealed temper tubes may have a dull iridescent film on both the inside and outside surface, and drawn temper tubes may have a superficial film of drawing lubricant on the surfaces.

## 14. Sampling

14.1 *Sampling*—The lot size, portion size, and selection of pieces shall be as follows:

### 14.1.1 Lot Size:

Outside Diameter, in. (mm)	Lot Size, lb (kg)
Up to 4 (102)	10 000 (4550)
(102), incl	
Over 4 (102)	20 000 (9100)

### 14.1.2 Portion Size:

No. of Pieces in Lot	No. of Sample Pieces to Be Taken
1 to 50	1
51 to 200	2
201 to 1500	3
Over 1500	0.2 % of the total number of pieces in the lot

14.2 *Chemical Analysis*—Samples for chemical analysis shall be taken in accordance with Practice E255. Drillings, millings, and so forth shall be taken in approximately equal weight from each of the sample pieces selected in accordance with 14.1.2 and combined into one composite sample. The minimum weight of the composite sample that is to be divided into three equal parts shall be 150 g.

14.2.1 Instead of sampling in accordance with Practice E255, the manufacturer shall have the option of determining conformance to chemical composition as follows: Conformance shall be determined by the manufacturer by analyzing samples taken at the time the castings are poured or samples taken from the semifinished product. If the manufacturer determines the chemical composition of the material during the course of manufacture, he shall not be required to sample and analyze the finished product. The number of samples taken for determination of chemical composition shall be as follows:

TABLE 5. Average Outside Diameter<sup>A</sup> Tolerances

Specified Diameter, in. (mm)	Tolerances, plus and minus, <sup>B</sup> in. (mm) for Pipe of Copper Alloy UNS Nos. C70600, C71000, C71500
Over 2 to 3 (50.8 to 76.2), incl	0.005 (0.13)
Over 3 to 4 (76.2 to 102), incl	0.006 (0.15)
Over 4 to 5 (102 to 127), incl	0.008 (0.20)
Over 5 to 6 (127 to 152), incl	0.009 (0.23)
Over 6 to 8 (152 to 203), incl	0.010 (0.25)
Over 8 to 10 (203 to 254), incl	0.013 (0.33)
Over 10 to 12 (254 to 305), incl	0.015 (0.38)
Over 12 (305)	0.5 %

<sup>A</sup> The average outside diameter of a pipe is the average of the maximum and minimum outside diameters, as determined at any one cross section.

<sup>B</sup> If tolerances all plus or all minus are desired, double the values given.

TABLE 6 Wall Thickness Tolerances, in. (mm)

NOTE 1—Maximum Deviation at Any Point: The following tolerances are plus and minus; if tolerances all plus or all minus are desired, double the values given.

Wall Thickness, in. (mm)	Outside Diameter, in. (mm)					
	Up to 2½ (63.5), incl	Over 2½ to 4½ (63.5 to 114), incl	Over 4½ to 6½ (114 to 165), incl	Over 6½ to 9 (165 to 230), incl	Over 9 to 11½ (230 to 292), incl	Over 11½ (292)
To 0.017 (0.43), incl	0.0013 (0.0033)	...	...	...	...	...
Over 0.017 to 0.021 (0.43 to 0.53), incl	0.0015 (0.038)	...	...	...	...	...
Over 0.021 to 0.026 (0.53 to 0.66), incl	0.002 (0.051)	...	...	...	...	...
Over 0.026 to 0.037 (0.66 to 0.94), incl	0.0025 (0.064)	0.003 (0.076)	...	...	...	...
Over 0.037 to 0.050 (0.94 to 1.27), incl	0.003 (0.076)	0.0035 (0.089)	0.0035 (0.089)	...	...	...
Over 0.050 to 0.073 (1.27 to 1.85), incl	0.0035 (0.089)	0.004 (0.10)	0.004 (0.10)	0.007 (0.18)	...	...
Over 0.073 to 0.130 (1.85 to 3.30), incl	0.004 (0.10)	0.0045 (0.11)	0.0045 (0.11)	0.008 (0.20)	...	...
Over 0.130 to 0.205 (3.30 to 5.20), incl	0.0045 (0.11)	0.005 (0.12)	0.005 (0.12)	0.010 (0.25)	0.012 (0.30)	0.014 (0.36)
Over 0.205 to 0.300 (5.20 to 7.61), incl	0.005 (0.12)	0.006 (0.15)	0.006 (0.15)	0.012 (0.30)	0.014 (0.36)	0.018 (0.46)
Over 0.300 to 0.500 (7.61 to 12.7) and over	0.006 (0.15)	0.007 (0.18)	0.007 (0.18)	0.019 (0.48)	0.017 (0.43)	0.023 (0.58)

TABLE 7 Length Tolerances for Pipe Furnished in Straight Lengths<sup>A</sup>

Length	Tolerances, in. (mm) Applicable Only to Full-Length Pieces
Specific Lengths:	
Up to 6 in. (152 mm), incl	1/16 (1.6)
Over 6 in. to 2 ft (152 to 610 mm), incl	3/32 (2.4)
Over 2 to 6 ft (610 mm to 1.83 m), incl	1/8 (3.2)
Over 6 to 14 ft (1.83 to 4.27 m), incl	1/4 (6.4)
Over 14 ft (4.27 m)	1/2 (13)
Specific lengths with ends	1 (25)
Stock lengths with or without ends	1 (25)

<sup>A</sup> As stock lengths are cut and placed in stock in advance of orders, departure from this tolerance is not practicable.

TABLE 8 Schedule of Specific and Stock Lengths with Ends Included

Major Outside Dimensions, in. (mm)	Nominal Length, ft (m)	Shortest Permissible Length, <sup>A</sup> % of Nominal Length	Maximum Permissible Weight of Ends, % of Lot Weight
Up to 3 (76.2), incl	6 to 20 (1.85 to 6.10), incl	55	30
Over 3 to 3½ (76.2 to 88.9), incl	6 to 20 (1.85 to 6.10), incl	50	40

<sup>A</sup> Expressed to the nearest 1/2 ft (150 mm).

14.2.1.1 When samples are taken at the time the castings are poured, at least one sample shall be taken for each group of castings poured simultaneously from the same source of molten metal.

14.2.1.2 When samples are taken from the semifinished product, a sample shall be taken to represent each 10 000 lb (4550 kg) or fraction thereof, except that not more than one sample shall be required per piece.

14.2.1.3 Due to the discontinuous nature of the processing of castings into wrought products, it is not practical to identify specific castings analysis with a specific quantity of finished material.

14.2.1.4 In the event that heat identification or traceability is required, the purchaser shall specify the details desired.

14.3 Tension Tests—For the tension tests a specimen shall be taken from each of the pieces selected in accordance with

14.1. The required tension tests shall be made on each of the specimens so selected.

14.3.1 The required tension tests shall be made on each of the specimens so selected.

15. Number of Tests and Retests

15.1 Tests:

15.1.1 Chemical Analysis—Chemical composition shall determine as the per element mean of the results from at least two replicate analyses of the samples, and the results of each replication must meet the requirements of the product specification.

15.1.2 Tension Tests—When tensile strength is specified, two tubes shall be selected from each lot and subjected to the tension test which shall, in case of disagreement, be made in accordance with Test Methods E8/E8M.

15.1.3 Other Tests—For tests specified in Section 10, specimens shall be taken from each of the pieces selected in accordance with 14.1.

15.2 Retests:

15.2.1 When test results obtained by the purchaser fail to conform with the product specification requirement(s), the manufacturer or supplier shall have the option to perform a retest.

15.2.2 Retesting shall be as directed in this specification for the initial test, except the number of test specimens shall be twice that required normally for the test.

15.2.3 Test results for all specimens shall conform to the requirement(s) of this specification in retest, and failure to comply shall be cause for lot rejection.

16. Specimen Preparation

16.1 Chemical Analysis:

16.1.1 Preparation of the analytical test specimen shall be the responsibility of the reporting laboratory.

16.2 Tensile Test:

16.2.1 Tension test specimens shall be of the full section of the pipe and shall conform to the requirements of Test Specimens section of Test Methods E8/E8M, unless the limitations of the testing machine preclude the use of such a specimen. Test specimens conforming to Type No. 1 of Fig. 13, Tension Test Specimen for Large-Diameter Tubular Products,

of Test Methods E8/E8M may be used when a full-section specimen cannot be tested.

16.2.2 When the limitations of the testing machine preclude the use of a full specimen, specimens conforming to Tension Test Specimens for Large-Diameter Tubular Products of Test Methods E8/E8M shall be used.

### 16.3 Expansion Test:

16.3.1 Test specimen shall conform to the requirements of the Specimen Preparation section of Test Method B153.

### 16.4 Flattening Test:

16.4.1 The flattening test shall be performed in accordance with Test Method section in Test Method B968/B968M.

## 17. Test Methods

17.1 In cases of disagreement, test methods for chemical analysis shall be subject to agreement between the manufacturer or supplier and the purchaser. The following table is a list of published test methods, some of which are considered by ASTM as no longer viable. These and others not listed may be used subject to agreement.

Element	Method
Copper 60 to 99.74	E478 Electrolytic
Nickel, inc. Cobalt	E478 Gravimetric
Lead 0.05 to 0.10	E478 Atomic Absorption
Iron 0.05 to 1.8	E54
Zinc to 1.0	E478 Atomic Absorption
Manganese to 1.0	E62
Phosphorus 0.001 to 0.04	E62

17.2 Tension test specimens shall be of the full section of the tube and shall conform to the requirements of the Significance and Use section of Test Methods E8/E8M.

17.3 Whenever tension test results are obtained from both full-size and from machined test specimens and they differ, the results obtained from full-size test specimens shall be used to determine conformance to the specification requirements.

17.4 Tension test results on material covered by this specification are not seriously affected by variations in speed of testing. A considerable range of testing speed is permissible; however, the rate of stressing to the yield strength should not exceed 100 ksi/min (690 MPa/min). Above the yield strength the movement per minute of the testing machine head under load should not exceed 0.5 in./in. (0.5 mm/mm) of gage length (or distance between grips for full-section specimens).

17.5 *Flattening Test*—The flattening test shall be performed in accordance with Test Method section in Test Method B968/B968M.

## 18. Significance of Numerical Limits

18.1 For purposes of determining compliance with the specified limits for requirements of the properties listed in the following table, and observed value or a calculated value shall be rounded as indicated in accordance with the rounding method of Practice E29.

Property	Rounded Unit for Observed or Calculated Value
Chemical composition	nearest unit in the last right-hand place of figures of the specified limit
Tensile strength	nearest ksi (nearest MPa up to 10 ksi, incl, nearest 5 MPa over 10 ksi)
Yield strength	nearest 1 %
Elongation	

## 19. Inspection

19.1 The manufacturer, or supplier, shall inspect and make tests necessary to verify the product furnished conforms to specification requirements.

19.2 Source inspection of the product by the purchaser may be agreed upon between the manufacturer, or supplier, and the purchaser as part of the purchase order. In such case, the nature of the facilities needed to satisfy the inspector representing the purchaser that the product is being furnished in accordance with the specification shall be included in the agreement. All tests and the inspection shall be conducted so as not to interfere unnecessarily with the operation of the works.

19.3 The manufacturer, or supplier, and the purchaser may conduct the final inspection simultaneously by mutual agreement.

## 20. Rejection and Rehearing

### 20.1 Rejection:

20.1.1 Product that fails to conform to the specification requirements, when tested by the purchaser or purchaser's agent, may be rejected.

20.1.2 Rejection shall be reported to the manufacturer or supplier promptly. In addition a written notification of rejection shall follow.

20.1.3 In case of dissatisfaction with the results of the test upon which rejection is based, the manufacturer or supplier, shall have the option to make claim for a rehearing.

20.2 *Rehearing*—As a result of product rejection, the manufacturer or supplier shall have the option to make claim for a retest to be conducted by the manufacturer or supplier and the purchaser. Samples of the rejected product shall be taken in accordance with the product specification and subjected to test by both parties using the test method(s) specified in the product specification, or, upon agreement of both parties, an independent laboratory may be selected for the test(s) using the test method(s) specified in the product specification.

## 21. Certification

21.1 When specified on the purchase order, the manufacturer shall furnish to the purchaser a certificate stating that each lot has been sampled, tested, and inspected in accordance with this specification and has met the requirements.

21.2 When material is specified to meet the requirements of *ASME Boiler and Pressure Vessel Code*, the certification requirements are mandatory.

## 22. Test Report

22.1 When specified in the contract or purchase order, a report of test results shall be furnished.

**23. Packaging and Package Marking**

23.1 The material shall be separated by size, composition, and temper, and prepared for shipment in such a manner as to ensure acceptance by common carrier for transportation and to afford protection from the normal hazards of transportation.

23.2 Each shipping unit shall be legibly marked with the purchase order number, metal or alloy designation, temper,

size, shape, total length or piece count, or both, and name of supplier. The specification number shall be shown when specified.

**24. Keywords**

24.1 copper nickel; pipe; welded pipe; UNS No. C70600; UNS No. C70620; UNS No. C71500; UNS No. C71520

**APPENDIXES**

(Nonmandatory Information)

**X1. SUGGESTED SIZES FOR PIPE**

X1.1 Suggested wall thickness for welded copper-nickel alloy pipe are given in Table X1.1.

**TABLE X1.1 Suggested Wall Thicknesses<sup>A</sup> of Welded Pipe Based on SPS Diameters**

SPS, in.	Outside Diameter, in. (mm)	Wall Thickness, in. (mm)		
		A	B	C
2.5	2.875 (73.0)	...	0.083 (2.11)	0.134 (3.40)
3	3.500 (88.9)	...	0.095 (2.42)	0.165 (4.19)
3.5	4.000 (102)	...	0.095 (2.42)	0.180 (4.57)
4	4.500 (114)	...	0.109 (2.77)	0.203 (5.15)
4.5	5.000 (127)	...	0.120 (3.05)	0.203 (5.15)
5	5.563 (141)	...	0.125 (3.17)	0.220 (5.59)
6	6.625 (168)	...	0.134 (3.40)	0.259 (6.57)
7	7.625 (194)	...	0.134 (3.40)	0.284 (7.21)
8	8.625 (219)	...	0.148 (3.76)	0.340 (8.64)
9	9.625 (244)	...	0.187 (4.75)	0.340 (8.64)
10	10.750 (273)	0.134 (3.40)	0.187 (4.75)	0.380 (9.65)
12	12.750 (324)	0.156 (3.96)	0.250 (6.35)	0.454 (11.5)
14	14.0 (355)	0.165 (4.19)	...	...
16	16.0 (406)	0.165 (4.19)	...	...
18	18.0 (457)	0.180 (4.57)	...	...
20	20.0 (508)	0.180 (4.57)	...	...
24	24.0 (609)	0.180 (4.57)	...	...
30	30.0 (761)	0.250 (6.35)	...	...

<sup>A</sup> These wall thicknesses correspond to MIL-T-16420 classes for the same outside diameter.  
 Column A—Class 50  
 Column B—Class 200  
 Column C—Class 700

**X2. METRIC EQUIVALENTS**

X2.1 The SI unit for strength properties now shown is in accordance with the International System of Units (SI). The derived SI unit for force is the newton (N), which is defined as that force which when applied to a body having a mass of one kilogram gives it an acceleration of one metre per second squared ( $N = kg \cdot m/s^2$ ). The derived SI unit for pressure or

stress is the newton per square metre ( $N/m^2$ ), which has been named the pascal (Pa) by the General Conference on Weights and Measures. Since  $1 \text{ ksi} = 6\,894\,757 \text{ Pa}$ , the metric equivalents are expressed as megapascal (MPa), which is the same as  $MN/m^2$  and  $N/mm^2$ .

## SUMMARY OF CHANGES

Committee B05 has identified the location of selected changes to this specification since the last issue (B467-09 that may impact the use of this standard. (Approved April 1, 2014.)

- (1) Added Test Method B968/B968M. (3) Added Practice E255.  
(2) Editorial revisions in accordance with Guide B950.

*ASTM International takes no position respecting the validity of any patent rights asserted in connection with any item mentioned in this standard. Users of this standard are expressly advised that determination of the validity of any such patent rights, and the risk of infringement of such rights, are entirely their own responsibility.*

*This standard is subject to revision at any time by the responsible technical committee and must be reviewed every five years and if not revised, either reapproved or withdrawn. Your comments are invited either for revision of this standard or for additional standards and should be addressed to ASTM International Headquarters. Your comments will receive careful consideration at a meeting of the responsible technical committee, which you may attend. If you feel that your comments have not received a fair hearing you should make your views known to the ASTM Committee on Standards, at the address shown below.*

*This standard is copyrighted by ASTM International, 100 Barr Harbor Drive, PO Box C700, West Conshohocken, PA 19428-2959, United States. Individual reprints (single or multiple copies) of this standard may be obtained by contacting ASTM at the above address or at 610-832-9585 (phone), 610-832-9555 (fax), or service@astm.org (e-mail); or through the ASTM website (www.astm.org). Permission rights to photocopy the standard may also be secured from the Copyright Clearance Center, 222 Rosewood Drive, Danvers, MA 01923, Tel: (978) 646-2600; http://www.copyright.com/*

ASMENORMDOC.COM : Click to view the full PDF of ASME BPVC.II.B (ASME BPVC Section II part B) 2025

INTENTIONALLY LEFT BLANK

# SPECIFICATION FOR WELDED UNS N08020, N08024, AND N08026 ALLOY TUBES



**SB-468**

(Identical with ASTM Specification B468-04 (2009) except that certification has been made mandatory.)

ASMENORMDOC.COM : Click to view the full PDF of ASME BPVC.II.B (ASME BPVC Section II part B) 2025

# SPECIFICATION FOR WELDED UNS N08020, N08024, AND N08026 ALLOY TUBES



SB-468

[Identical with ASTM Specification B 468-04(2009) except that certification has been made mandatory.]

## 1. Scope

**1.1** This specification covers welded UNS N08020, N08024, and N08026 alloy boiler, heat exchanger, and condenser tubes for general corrosion-resisting and low- or high-temperature service.

**1.2** This specification covers tubes  $\frac{1}{8}$  to 5 in. (3.18 to 127 mm), inclusive, in outside diameter and 0.015 to 0.500 in. (0.38 to 12.70 mm), inclusive, in wall thickness. Table 2 of Specification B 751 lists the dimensional requirements of these sizes. Tubes having other dimensions may be furnished provided such tubing complies with all other requirements of this specification.

**1.3** The values stated in inch-pound units are to be regarded as the standard. The values given in parentheses are for information only.

**1.4** *This standard does not purport to address all of the safety concerns, if any, associated with its use. It is the responsibility of the user of this standard to become familiar with all hazards including those identified in the appropriate Material Safety Data Sheet for this product/material as provided by the manufacturer, to establish appropriate safety and health practices, and determine the applicability of regulatory limitations prior to use.*

## 2. Referenced Documents

### 2.1 ASTM Standards:

- A 262 Practices for Detecting Susceptibility to Intergranular Attack in Austenitic Stainless Steels
- B 751 Specification for General Requirements for Nickel and Nickel-Alloy Welded Tube
- B 899 Terminology Relating to Non-ferrous Metals and Alloys

## 3. Terminology

### 3.1 Definitions:

**3.1.1** Definitions for terms defined in Terminology B 899 shall apply unless otherwise defined by the requirements of this document.

## 4. General Requirement

**4.1** Material furnished in accordance with this specification shall conform to the applicable requirements of the current edition of Specification B 751 unless otherwise provided herein.

## 5. Ordering Information

**5.1** It is the responsibility of the purchaser to specify all requirements that are necessary for material ordered under this specification. Examples of such requirements include, but are not limited to, the following:

**5.1.1** Quantity (feet or number of lengths),

**5.1.2** UNS number,

**5.1.3** Size (outside diameter and minimum or average wall thickness),

**5.1.4** Length (random or specific),

**5.1.5** ASTM designation,

**5.1.6** *Product Analysis* — State if required,

**5.1.7** DELETED

**5.1.8** *Purchaser Inspection* — State which tests or inspections are to be witnessed, if any, and

**5.1.9** Supplementary requirements, if any.

## 6. Materials and Manufacture

**6.1** The tubing shall be made from flat-rolled stock by an automatic welding process with no addition of filler metal. Subsequent to welding and prior to final heat treatment, the material shall be cold-worked in either the weld metal only, or in both the weld and base metal.

**6.2** *Heat Treatment* — Tubing of UNS N08020 alloy shall be furnished in the stabilized-annealed condition. Tubing of UNS N08024 alloy shall be furnished in the annealed condition. Tubing of UNS N08026 alloy shall be furnished in the solution-annealed condition.

TABLE 1  
CHEMICAL REQUIREMENTS

Element	Composition, %		
	UNS N08020	UNS N08024	UNS N08026
Carbon, max	0.07	0.03	0.03
Manganese, max	2.00	1.00	1.00
Phosphorus, max	0.045	0.035	0.03
Sulfur, max	0.035	0.035	0.03
Silicon, max	1.00	0.50	0.50
Nickel	32.00–38.00	35.00–40.00	33.00–37.20
Chromium	19.00–21.00	22.50–25.00	22.00–26.00
Molybdenum	2.00–3.00	3.50–5.00	5.00–6.70
Copper	3.00–4.00	0.50–1.50	2.00–4.00
Columbium (Nb) + tantalum	8× carbon–1.00	0.15–0.35	
Nitrogen	...	...	0.10–0.16
Iron <sup>4</sup>	Remainder	Remainder	Remainder

<sup>4</sup> By difference.

NOTE 1 — The recommended annealing temperatures are 1800 to 1850°F (982 to 1010°C) for UNS N08020, 1925 to 1975°F (1052 to 1079°C) for UNS N08024, and 2050 to 2200°F (1121 to 1204°C) for UNS N08026.

## 7. Chemical Composition

**7.1** The material shall conform to the composition limits specified in Table 1. One test is required for each lot as defined in Specification B 751.

**7.2** If a product analysis is performed, it shall meet the chemistry limits prescribed in Table 1, subject to the analysis tolerances specified in Table 6 of Specification B 751.

## 8. Mechanical Properties and Other Requirements

**8.1 Mechanical Properties** — The material shall conform to the mechanical property requirements specified in Table 2. One test is required for each lot as defined in Specification B 751.

**8.2 Flattening Test** — A flattening test shall be made on each end of one tube per lot. Superficial ruptures

TABLE 2  
MECHANICAL PROPERTY REQUIREMENTS

Tensile Strength, min, ksi (MPa)	Yield Strength, min, ksi (MPa)	Elongation in 2 in. (50.8 mm), min, %
80 (551)	35 (241)	30.0

resulting from surface imperfections shall not be cause for rejection.

**8.3 Flange Test** — A flange test shall be made on each end of one tube per lot.

**8.4 Nondestructive Test Requirements** — Each tube shall be subjected to either a pressure test or a nondestructive electric test at the manufacturer's option. The purchaser may specify which test is to be used.

## 9. Keywords

**9.1** welded tube; N08020; N08024; N08026



# SPECIFICATION FOR UNS N08020, UNS N08024, AND UNS N08026 NICKEL ALLOY BAR AND WIRE



SB-473

(Identical with ASTM Specification B473-07 (2013) except that certification has been made mandatory.)

ASMENORMDOC.COM : Click to view the full PDF of ASME BPVC.II.B (ASME BPVC Section II part B) 2025

# SPECIFICATION FOR UNS N08020, UNS N08024, AND UNS N08026 NICKEL ALLOY BAR AND WIRE



SB-473

(Identical with ASTM Specification B 473-07(2013) except that certification has been made mandatory.)

## 1. Scope

**1.1** This specification covers UNS N08020, UNS N08026, and UNS N08024 bar and wire other than required for reforging.

**1.2** The values stated in inch-pound units are to be regarded as the standard. The values given in parentheses are for information only.

**1.3** *This standard does not purport to address all of the safety concerns, if any, associated with its use. It is the responsibility of the user of this standard to become familiar with all hazards including those identified in the appropriate Material Safety Data Sheet (MSDS) for this product/material as provided by the manufacturer, to establish appropriate safety and health practices, and determine the applicability of regulatory limitations prior to use.*

## 2. Referenced Documents

### 2.1 ASTM Standards:

- A 262 Practices for Detecting Susceptibility to Intergranular Attack in Austenitic Stainless Steels
- B 880 Specification for General Requirements for Chemical Check Analysis Limits for Nickel, Nickel Alloys and Cobalt Alloys
- E 8 Test Methods for Tension Testing of Metallic Materials
- E 1473 Test Methods for Chemical Analysis of Nickel, Cobalt, and High-Temperature Alloys

## 3. Terminology

### 3.1 Definitions of Terms Specific to This Standard:

**3.1.1** The terms bar and wire as used in this specification are described as follows:

**3.1.2 bars, *n*** — hot-finished rounds, squares, octagons, and hexagons:  $\frac{1}{4}$  in. (6.35 mm) and over in diameter

or size. Hot-finished flats:  $\frac{1}{4}$  to 10 in. (254 mm), inclusive, in width,  $\frac{1}{8}$  in. (3.175 mm) and over in thickness. Cold-finished rounds, squares, octagons, hexagons, and shapes: over  $\frac{1}{2}$  in. (12.7 mm) in diameter or size. Cold-finished flats:  $\frac{3}{8}$  in. (9.525 mm) and over in width (see Discussion(1)),  $\frac{1}{8}$  in. and over in thickness (see Discussion(2)).

**3.1.2.1 Discussion** — (1) Widths less than  $\frac{3}{8}$  in. (9.525 mm) and thicknesses less than  $\frac{3}{16}$  in. (4.75 mm) are generally described as flat wire.

**3.1.2.2 Discussion** — (2) Thicknesses  $\frac{1}{8}$  in. (3.175 mm) to under  $\frac{3}{16}$  in. (4.75 mm) can be cold-rolled strip as well as bar.

**3.1.3 wire, *n*** — cold finished only: round, square, octagon, hexagon, and shape wire,  $\frac{1}{2}$  in. (12.7 mm) and under in diameter or size. Cold-finished only: flat wire,  $\frac{3}{16}$  in. (4.76 mm) to under  $\frac{3}{8}$  in. (9.525 mm) in width, 0.010 in. (0.254 mm) to under  $\frac{3}{16}$  in. in thickness.

## 4. Ordering Information

**4.1** It is the responsibility of the purchaser to specify all requirements that are necessary for the safe and satisfactory performance of material ordered under this specification. Examples of such requirements include, but are not limited to, the following:

- 4.1.1** Quantity (weight or number of pieces),
- 4.1.2** Name of material or UNS number,
- 4.1.3** Form (bar or wire),
- 4.1.4** Dimensions,
- 4.1.5** Condition,
- 4.1.6** Finish,
- 4.1.7** ASTM designation and year of issue,
- 4.1.8** Inspection (15.1),
- 4.1.9** Supplementary requirements, if any, and

TABLE 1  
CHEMICAL REQUIREMENTS

Element	Composition, %		
	UNS N08026	UNS N08020	UNS N08024
Carbon, max	0.03	0.07	0.03
Manganese, max	1.00	2.00	1.00
Phosphorus, max	0.03	0.045	0.035
Sulfur, max	0.03	0.035	0.035
Silicon, max	0.50	1.00	0.50
Nickel	33.00 to 37.20	32.00 to 38.00	35.00 to 40.00
Chromium	22.00 to 26.00	19.00 to 21.00	22.50 to 25.00
Molybdenum	5.00 to 6.70	2.00 to 3.00	3.50 to 5.00
Copper	2.00 to 4.00	3.00 to 4.00	0.50 to 1.50
Columbium (Nb) + tantalum	...	8 × carbon–1.00	0.15 to 0.35
Nitrogen	0.10 to 0.16	...	...
Iron	remainder <sup>A</sup>	remainder <sup>A</sup>	remainder <sup>A</sup>

<sup>A</sup> By difference.

**4.1.10** If possible, the intended end use.

NOTE 1 — A typical ordering description is as follows: 200 bars, UNS N08020, 1 in. (25.4 mm) round by 10 to 14 ft (3.0 to 3.6 m), centerless ground, Specification B 473.

## 5. Materials and Manufacture

**5.1 Heat Treatment** — The product of UNS N08020 alloy shall be furnished in the stabilized-annealed condition. The product of UNS N08026 alloy shall be furnished in the solution-annealed condition. The product of UNS N08024 alloy shall be furnished in the annealed condition.

NOTE 2 — The recommended annealing temperatures all followed by quenching in water or rapidly cooling by other means are as follows: 1700 to 1850°F (927 to 1010°C) for UNS N08020, 2050 to 2200°F (1121 to 1204°C) for UNS N08026, and 1925 to 1975°F (1052 to 1079°C) for UNS N08024.

## 6. Chemical Composition

**6.1** The material shall conform to the requirements as to chemical composition prescribed in Table 1.

**6.2** If a product (check) analysis is performed by the purchaser, the material shall conform to the product (check) analysis variations prescribed in Specification B 880.

## 7. Condition

**7.1** Bars shall be furnished annealed and either hot finished or cold finished. Strain-hardened material is available only as cold finished.

**7.2** Wire will be furnished only as annealed and cold finished.

## 8. Mechanical Properties

**8.1** The material shall conform to the applicable requirements as to mechanical properties prescribed in Table 2.

## 9. Dimensions and Permissible Variations

**9.1 Bar** — Bars shall conform to the variations in dimensions prescribed in Tables 3–11, inclusive, as applicable.

**9.2 Wire** — Wire shall conform to the permissible variations in dimensions prescribed in Tables 12–16, inclusive, as applicable.

## 10. Workmanship, Finish, and Appearance

**10.1** The product shall be uniform in quality and condition, smooth, commercially straight or flat, and free of injurious imperfections.

## 11. Sampling

### 11.1 Lot:

**11.1.1** A lot for chemical analysis shall consist of one heat.

**11.1.2** A lot for mechanical properties shall consist of all material from the same heat, nominal diameter or thickness, of each heat-treatment charge.

### 11.2 Test Material Selection:

**11.2.1 Chemical Analysis** — Representative samples shall be taken during pouring or subsequent processing.

**11.2.1.1** Check analysis shall be wholly the responsibility of the purchaser.

TABLE 2  
MECHANICAL PROPERTY REQUIREMENTS<sup>A</sup>

Condition	Diameter or Thickness, in. (mm)	Tensile Strength, min		Yield Strength, min		Elongation in 2 in. (50.8 mm), min, %	Reduction of area, min, %
		ksi	MPa	ksi	MPa		
Annealed, hot finished or cold finished	All	80	551	35	241	30.0 <sup>B</sup>	50.0
Annealed, strain-hardened	Up to 2 (50.8) incl	90	620	60	415	15.0	40.0

<sup>A</sup> For wire only, tensile strength 90 to 120.0 ksi (620 to 830 MPa); no requirements on yield strength, elongation, and reduction of area.  
<sup>B</sup> Cold-finished shapes require only 15%, minimum, elongation.

TABLE 3  
PERMISSIBLE VARIATIONS IN SIZE OF HOT-ROLLED ROUND AND SQUARE BARS

	Permissible Variations from Specified Size, in. (mm)		Out-of-Round <sup>A</sup> or Out-of-Square, <sup>B</sup> in. (mm)
	Over	Under	
$\frac{1}{4}$ (6.35) to $\frac{5}{16}$ (7.94), incl <sup>C,D</sup>	<i>E</i>	<i>E</i>	<i>E</i>
Over $\frac{5}{16}$ (7.94) to $\frac{7}{16}$ (11.11), incl <sup>C,D</sup>	0.006 (0.15)	0.006 (0.15)	0.009 (0.23)
Over $\frac{7}{16}$ (11.11) to $\frac{5}{8}$ (15.88), incl <sup>C,D</sup>	0.007 (0.18)	0.007 (0.18)	0.010 (0.25)
Over $\frac{5}{8}$ (15.88) to $\frac{7}{8}$ (22.22), incl	0.008 (0.20)	0.008 (0.20)	0.012 (0.30)
Over $\frac{7}{8}$ (22.22) to 1 (25.40), incl	0.009 (0.23)	0.009 (0.23)	0.013 (0.33)
Over 1 (25.40) to $1\frac{1}{8}$ (28.58), incl	0.010 (0.25)	0.010 (0.25)	0.015 (0.38)
Over $1\frac{1}{8}$ (28.58) to $1\frac{1}{4}$ (31.75), incl	0.011 (0.28)	0.011 (0.28)	0.016 (0.41)
Over $1\frac{1}{4}$ (31.75) to $1\frac{3}{8}$ (34.92), incl	0.012 (0.30)	0.012 (0.30)	0.018 (0.46)
Over $1\frac{3}{8}$ (34.92) to $1\frac{1}{2}$ (38.10), incl	0.014 (0.36)	0.014 (0.36)	0.021 (0.53)
Over $1\frac{1}{2}$ (38.10) to 2 (50.80), incl	$\frac{1}{64}$ (0.40)	$\frac{1}{64}$ (0.40)	0.023 (0.58)
Over 2 (50.80) to $2\frac{1}{2}$ (63.50), incl	$\frac{1}{32}$ (0.79)	0	0.023 (0.58)
Over $2\frac{1}{2}$ (63.50) to $3\frac{1}{2}$ (88.90), incl	$\frac{3}{64}$ (1.19)	0	0.035 (0.89)
Over $3\frac{1}{2}$ (88.90) to $4\frac{1}{2}$ (114.30), incl	$\frac{1}{16}$ (1.59)	0	0.046 (1.17)
† Over $4\frac{1}{2}$ (114.30) to $5\frac{1}{2}$ (139.70), incl	$\frac{5}{64}$ (1.98)	0	0.058 (1.47)
Over $5\frac{1}{2}$ (139.70) to $6\frac{1}{2}$ (165.10), incl	$\frac{1}{8}$ (3.18)	0	0.070 (1.78)
Over $6\frac{1}{2}$ (165.10) to 8 (203.20), incl	$\frac{5}{32}$ (3.97)	0	0.085 (2.18)

<sup>A</sup> Out-of-round is the difference between the maximum and minimum diameters of the bar, measured at the same cross section.  
<sup>B</sup> Out-of-square section is the difference in the two dimensions at the same cross section of a square bar, each dimension being the distance between opposite faces.  
<sup>C</sup> Size tolerances have not been evolved for rounds in the size range of  $\frac{1}{4}$  to  $\frac{5}{16}$  in. (6.35 to 7.94 mm), inclusive. Size tolerances have not been evolved for round sections in the size range of  $\frac{1}{4}$  in. to approximately  $\frac{5}{8}$  in. (6.35 to 15.88 mm) in diameter which are produced on rod mills in coils.  
<sup>D</sup> Variations in size of coiled product made on rod mills are greater than size tolerances for product made on bar mills.  
<sup>E</sup> Squares in this size are not produced as hot-rolled products.  
 † Editorially corrected.

TABLE 4  
PERMISSIBLE VARIATIONS IN SIZE OF HOT-ROLLED HEXAGONAL AND OCTAGONAL BARS

Specified Sizes Measured Between Opposite Sides, in. (mm)	Permissible Variations from Specified Size, in. (mm)		Maximum Difference in 3 Measurements for Hexagons only, in. (mm)
	Over	Under	
$\frac{1}{4}$ (6.35) to $\frac{1}{2}$ (12.70), incl	0.007 (0.18)	0.007 (0.18)	0.011 (0.28)
Over $\frac{1}{2}$ (12.70) to 1 (25.40), incl	0.010 (0.25)	0.010 (0.25)	0.015 (0.38)
Over 1 (25.40) to $1\frac{1}{2}$ (38.10), incl	0.021 (0.53)	0.021 (0.53)	0.025 (0.64)
Over $1\frac{1}{2}$ (38.10) to 2 (50.80), incl	$\frac{1}{32}$ (0.79)	$\frac{1}{32}$ (0.79)	$\frac{1}{32}$ (0.79)
Over 2 (50.80) to $2\frac{1}{2}$ (63.50), incl	$\frac{3}{64}$ (1.19)	$\frac{3}{64}$ (1.19)	$\frac{3}{64}$ (1.19)
Over $2\frac{1}{2}$ (63.50) to $3\frac{1}{2}$ (88.90), incl	$\frac{1}{16}$ (1.59)	$\frac{1}{16}$ (1.59)	$\frac{1}{16}$ (1.59)

**TABLE 5**  
**PERMISSIBLE VARIATIONS IN THICKNESS AND WIDTH FOR HOT-ROLLED FLAT BARS**

Specified Width, in. (mm)	Permissible Variations in Thickness for Thicknesses Given, in. (mm)					
	$\frac{1}{8}$ (3.18) to $\frac{1}{2}$ (12.70), incl		Over $\frac{1}{2}$ (12.70) to 1 (25.40), incl		Over 1 (25.40) to 2 (50.80), incl	
	Over	Under	Over	Under	Over	Under
To 1 (25.40), incl	0.008 (0.20)	0.008 (0.20)	0.010 (0.25)	0.010 (0.25)	...	...
Over 1 (25.40) to 2 (50.80), incl	0.012 (0.30)	0.012 (0.30)	0.015 (0.38)	0.015 (0.38)	0.031 (0.79)	0.031 (0.79)
Over 2 (50.80) to 4 (101.60), incl	0.015 (0.38)	0.015 (0.38)	0.020 (0.51)	0.020 (0.51)	0.031 (0.79)	0.031 (0.79)
Over 4 (101.60) to 6 (152.40), incl	0.015 (0.38)	0.015 (0.38)	0.020 (0.51)	0.020 (0.51)	0.031 (0.79)	0.031 (0.79)
Over 6 (152.40) to 8 (203.20), incl	0.016 (0.41)	0.016 (0.41)	0.025 (0.64)	0.025 (0.64)	0.031 (0.79)	0.031 (0.79)
Over 8 (203.20) to 10 (254.00), incl	0.021 (0.53)	0.021 (0.53)	0.031 (0.79)	0.031 (0.79)	0.031 (0.79)	0.031 (0.79)
Specified Width, in. (mm)	Over 2 (50.80) to 4 (101.60), incl		Over 4 (101.60) to 6 (152.40), incl		Over 6 (152.40) to 8 (203.20), incl	
	Over	Under	Over	Under	Over	Under
	To 1 (25.40), incl	...	...	...	...	...
Over 1 (25.40) to 2 (50.80), incl	...	...	...	...	...	...
Over 2 (50.80) to 4 (101.60), incl	0.062 (1.57)	0.031 (0.79)	...	...	...	...
Over 4 (101.60) to 6 (152.40), incl	0.062 (1.57)	0.031 (0.79)	0.093 (2.36)	0.062 (1.57)	...	...
Over 6 (152.40) to 8 (203.20), incl	0.062 (1.57)	0.031 (0.79)	0.093 (2.36)	0.062 (1.57)	0.125 (3.18)	0.156 (3.96)
Over 8 (203.20) to 10 (254.00), incl	0.062 (1.57)	0.031 (0.79)	0.093 (2.36)	0.062 (1.57)	0.125 (3.18)	0.156 (3.96)
Specified Width, in. (mm)	Permissible Variations in Width, in. (mm)					
	Over			Under		
	To 1 (25.40), incl	0.015 (0.38)			0.015 (0.38)	
Over 1 (25.40) to 2 (50.80), incl	0.031 (0.79)			0.031 (0.79)		
Over 2 (50.80) to 4 (101.60), incl	0.062 (1.57)			0.031 (0.79)		
Over 4 (101.60) to 6 (152.40), incl	0.093 (2.36)			0.062 (1.57)		
Over 6 (152.40) to 8 (203.20), incl	0.125 (3.18)			0.156 (3.96)		
Over 8 (203.20) to 10 (254.00), incl	0.156 (3.96)			0.187 (4.75)		

**TABLE 6**  
**PERMISSIBLE VARIATIONS IN SIZE OF COLD-FINISHED ROUND BARS**

Specified Size, in. (mm)	Permissible Variations from Specified Size, in. (mm) <sup>A,B</sup>	
	Over	Under
	Over $\frac{1}{2}$ (12.70) to 1 (25.40), excl	0.002 (0.05)
1 (25.40) to $1\frac{1}{2}$ (38.10), excl	0.0025 (0.06)	0.0025 (0.06)
$1\frac{1}{2}$ (38.10) to 4 (101.60), incl <sup>C</sup>	0.003 (0.08)	0.003 (0.08)

<sup>A</sup> Unless otherwise specified, size tolerances are over and under as shown in the above table. When required, however, they may be specified all over and nothing under, or all under and nothing over, or any combination of over and under, if the total spread in size tolerance for a specified size is not less than the total spread shown in the table.

<sup>B</sup> When it is necessary to heat treat or heat treat and pickle after cold finishing, size tolerances are double those shown in the table.

<sup>C</sup> Cold-finished bars over 4 in. (101.60 mm) in diameter are produced; size tolerances for such bars have not been evolved.

TABLE 7  
PERMISSIBLE VARIATIONS IN SIZE OF COLD-FINISHED HEXAGONAL, OCTAGONAL, AND SQUARE BARS

Specified Size, in. (mm)	Permissible Variations from Specified Size, in. (mm) <sup>A</sup>	
	Over	Under
Over 1/2 (12.70) to 1 (25.40), incl	0	0.004 (0.10)
Over 1 (25.40) to 2 (50.80), incl	0	0.006 (0.15)
Over 2 (50.80) to 3 (76.20), incl	0	0.008 (0.20)
Over 3 (76.20)	0	0.010 (0.25)

<sup>A</sup> When it is necessary to heat treat or heat treat and pickle after cold finishing, size tolerances are double those shown in the table.

TABLE 8  
PERMISSIBLE VARIATIONS IN WIDTH AND THICKNESS OF COLD-FINISHED FLAT BARS

Width, in. (mm)	Permissible Variations in Width, over and under, in. (mm) <sup>A</sup>	
	For Thicknesses 1/4 (6.35) and Under	For Thicknesses Over 1/4 (6.35)
3/8 (9.52) to 1 (25.40), incl	0.004 (0.10)	0.002 (0.05)
Over 1 (25.40) to 2 (50.80), incl	0.006 (0.15)	0.003 (0.08)
Over 2 (50.80) to 3 (76.20), incl	0.008 (0.20)	0.004 (0.10)
Over 3 (76.20) to 4 1/2 (114.30), incl	0.010 (0.25)	0.005 (0.13)

Thickness, in. (mm)	Permissible Variations in Thickness, over and under, in. (mm) <sup>A</sup>
1/8 (3.18) to 1 (25.40), incl	0.002 (0.05)
Over 1 (25.40) to 2 (50.80), incl	0.003 (0.08)
Over 2 (50.80) to 3 (76.20), incl	0.004 (0.10)
Over 3 (76.20) to 4 1/2 (114.30), incl <sup>B</sup>	0.005 (0.13)

<sup>A</sup> When it is necessary to heat treat and pickle after cold finishing, size tolerances are double those shown in the table.

<sup>B</sup> Cold-finished flat bars over 4 1/2 in. (114.30 mm) wide or thick are produced; width and thickness tolerances for such bars have not been evolved.

**TABLE 9**  
**PERMISSIBLE VARIATIONS IN LENGTH OF HOT-FINISHED OR COLD-FINISHED BARS**

Specified Size of Rounds, Squares, Hexagons, and Octagons and Widths of Flats, <sup>4</sup> in. (mm)	Permissible Variations in Length, in. (mm)			
	For Lengths Up to 12 ft (3,658 mm), incl		For Lengths Over 12 (3,658 mm) to 25 ft (7,620 mm), incl	
	Over	Under	Over	Under
To 2 (50.80), incl	$\frac{1}{2}$ (12.70)	0	$\frac{3}{4}$ (19.05)	0
Over 2 (50.80) to 4 (101.60), incl	$\frac{3}{4}$ (19.05)	0	1 (25.40)	0
Over 4 (101.60) to 6 (152.40), incl	1 (25.40)	0	$1\frac{1}{4}$ (31.75)	0
Over 6 (152.40) to 9 (228.60), incl	$1\frac{1}{4}$ (31.75)	0	$1\frac{1}{2}$ (38.10)	0
Over 9 (228.60) to 12 (304.80), incl	$1\frac{1}{2}$ (38.10)	0	2 (50.80)	0

NOTE 1 — The order should specify random lengths or specific lengths. When random lengths are ordered, the length tolerance is not less than 24 in. (609.60 mm). When specific lengths are ordered, Table 10 or Table 11 shall apply.

<sup>4</sup> The maximum width of bar flats is 10 in. (254.00 mm).

**TABLE 10**  
**PERMISSIBLE VARIATIONS IN LENGTH OF HOT-FINISHED OR COLD-FINISHED BARS MACHINE CUT AFTER MACHINE STRAIGHTENING**

Specified Size of Rounds, Squares, Hexagons, and Octagons and Widths of Flats, <sup>4</sup> in. (mm)	Permissible Variations in Length, in. (mm)			
	For Lengths Up to 12 ft (3,658 mm), incl		For Lengths Over 12 (3,658 mm) to 25 ft (7,620 mm), incl	
	Over	Under	Over	Under
To 3 (76.20), incl	$\frac{1}{8}$ (3.18)	0	$\frac{3}{16}$ (4.76)	0
Over 3 (76.20) to 6 (152.40), incl	$\frac{3}{16}$ (4.76)	0	$\frac{1}{4}$ (6.35)	0
Over 6 (152.40) to 9 (228.60), incl	$\frac{1}{4}$ (6.35)	0	$\frac{5}{16}$ (7.94)	0
Over 9 (228.60) to 12 (304.80), incl	$\frac{1}{2}$ (12.70)	0	$\frac{1}{2}$ (12.70)	0

NOTE 1 — The order should specify random lengths or specific lengths. When random lengths are ordered, the length tolerance is not less than 24 in. (609.60 mm). When specific lengths are ordered, Table 9 or Table 10 shall apply.

<sup>4</sup> The maximum width of bar flats is 10 in. (254.00 mm).

**TABLE 11**  
**PERMISSIBLE VARIATIONS IN STRAIGHTNESS OF MACHINE STRAIGHTENED HOT-FINISHED OR COLD-FINISHED BARS**

Measurement is taken on the concave side of the bar with a straight edge.

Unless otherwise specified, hot-finished or cold-finished bars for machining purposes are furnished machine straightened to the following tolerances:

Hot finished:

$\frac{1}{8}$  in. (3.18 mm) in any 5 ft (1524 mm), but may not exceed  $\frac{1}{8}$  in. (3.18 mm) × [length in feet (mm)]/[5 ft (1524 mm)]

Cold finished:

$\frac{1}{16}$  in. (1.59 mm) in any 5 ft (1524 mm), but may not exceed  $\frac{1}{16}$  in. (1.59 mm) × [length in feet (mm)]/[5 ft (1524 mm)]

TABLE 12  
DIAMETER AND OUT-OF-ROUND TOLERANCES FOR ROUND WIRE (DRAWN,  
POLISHED, CENTERLESS GROUND, CENTERLESS GROUND AND POLISHED)<sup>A,B,C</sup>

Specified Diameter, in. (mm)	Diameter Tolerance, in. (mm)	
	Over	Under
0.5000 (12.70)	0.002 (0.05)	0.002 (0.05)
Under 0.5000 (12.70) to 0.3125 (7.94), incl	0.0015 (0.04)	0.0015 (0.04)
Under 0.3125 (7.94) to 0.0440 (1.12), incl	0.001 (0.03)	0.001 (0.03)
Under 0.0440 (1.12) to 0.0330 (0.84), incl	0.0008 (0.02)	0.0008 (0.02)
Under 0.0330 (0.84) to 0.0240 (0.61), incl	0.0005 (0.013)	0.0005 (0.013)
Under 0.0240 (0.61) to 0.0120 (0.30), incl	0.0004 (0.010)	0.0004 (0.010)
Under 0.0120 (0.30) to 0.0080 (0.20), incl	0.0003 (0.008)	0.0003 (0.008)
Under 0.0080 (0.20) to 0.0048 (0.12), incl	0.0002 (0.005)	0.0002 (0.005)
Under 0.0048 (0.12) to 0.0030 (0.08), incl	0.0001 (0.003)	0.0001 (0.003)

<sup>A</sup> Diameter tolerances are over and under as given in this table. Also, round wire can be produced to tolerances all over and nothing under, or all under and nothing over, or any combination over and under, if the total spread in diameter tolerances for a specified diameter is not less than the total spread given in this table.

<sup>B</sup> The maximum out-of-round tolerance for round wire is one half of the total size tolerance given in this table.

<sup>C</sup> When it is necessary to heat treat after cold finishing because of special mechanical property requirements, tolerances are commonly double those shown.

TABLE 13  
SIZE TOLERANCES FOR DRAWN WIRE IN  
HEXAGONS, OCTAGONS, AND SQUARES

Specified Size, <sup>A</sup> in. (mm)	Size Tolerance, in. (mm)	
	Over	Under
$\frac{1}{2}$ (12.70)	0	0.004 (0.10)
Under $\frac{1}{2}$ (12.70) to $\frac{5}{16}$ (7.94), incl	0	0.003 (0.08)
Under $\frac{5}{16}$ (7.94) to $\frac{3}{8}$ (3.18), incl	0	0.002 (0.05)

<sup>A</sup> Distance across flats.

TABLE 14  
LENGTH TOLERANCES FOR ROUND AND SHAPE, STRAIGHTENED AND CUT WIRE, EXACT LENGTH  
RESHEARED WIRE

Diameter, in. (mm)	Length, ft (mm)	Tolerance, in. (mm)	
		Over	Under
0.125 (3.18) and under	Up to 12 (3,658), incl	$\frac{1}{16}$ (1.59)	0
0.125 (3.18) and under	Over 12 (3,658)	$\frac{1}{8}$ (3.18)	0
Over 0.125 (3.18) to 0.500 (12.70), incl	Under 3 (914)	$\frac{1}{32}$ (0.79)	0
Over 0.125 (3.18) to 0.500 (12.70), incl	3 (914) to 12 (3,658), incl	$\frac{1}{16}$ (1.59)	0
Over 0.125 (3.18) to 0.500 (12.70), incl	Over 12 (3,658)	$\frac{1}{8}$ (3.18)	0

TABLE 15  
SIZE TOLERANCES FOR WIRE FOR WHICH THE FINAL OPERATION IS A SURFACE  
TREATMENT FOR THE PURPOSE OF REMOVING SCALE OR DRAWING LUBRICANT

Specified Size, in. (mm)	Tolerance, in. (mm)	
	Over	Under
$\frac{1}{2}$ (12.70)	0.004 (0.10)	0.004 (0.10)
Under $\frac{1}{2}$ (12.70) to $\frac{5}{16}$ (7.94), incl	0.003 (0.08)	0.003 (0.08)
Under $\frac{5}{16}$ (7.94) to 0.044 (1.12), incl	0.002 (0.05)	0.002 (0.05)
Under 0.044 (1.12) to 0.033 (0.84), incl	0.0013 (0.03)	0.0013 (0.03)
Under 0.033 (0.84) to 0.024 (0.61), incl	0.0008 (0.02)	0.0008 (0.02)

TABLE 16  
THICKNESS AND WIDTH TOLERANCES FOR COLD-FINISHED FLAT WIRE

Specified Width, in. (mm)	Thickness Tolerance, in. (mm), Over or Under, for Given Thicknesses, in. (mm)			Width Tolerance, in. (mm)	
	Under 0.029 (0.74)	0.029 (0.74) to 0.035 (0.89), excl	0.035 (0.89) to $\frac{3}{16}$ (4.76), excl	Over	Under
		0.0015 (0.04)	0.002 (0.05)		
Under $\frac{3}{8}$ (9.52) to $\frac{1}{16}$ (1.59), incl	0.001 (0.03)	0.0015 (0.04)	0.002 (0.05)	0.005 (0.13)	0.005 (0.13)

**11.2.2 Mechanical Properties** — Samples of the material to provide test specimens shall be taken from such locations in each lot as to be representative of that lot.

## 12. Number of Tests

**12.1 Chemical Analysis** — One test per lot.

**12.2 Mechanical Properties** — One test per lot.

## 13. Specimen Preparation

**13.1** Tension test specimens shall be taken from the material after final heat treatment, and shall be selected in the longitudinal direction. The tension test specimens shall conform to the appropriate sections of Test Methods E 8.

## 14. Test Methods

**14.1** The chemical composition and mechanical properties of the material as enumerated in this specification shall, in case of disagreement, be determined in accordance with the following methods:

Test	ASTM Designations
Chemical analysis	E 1473 <sup>A</sup>
Tension	E 8 <sup>A</sup>

<sup>A</sup> Iron shall be determined arithmetically by difference.

## 15. Inspection

**15.1** If specified, source inspection of the material by the purchaser at the manufacturer's plant shall be made as

agreed upon between the purchaser and the manufacturer as part of the purchase contract.

## 16. Rejection and Rehearing

**16.1** Material that fails to conform to the requirements of this specification may be rejected. Rejection should be reported to the producer or supplier promptly and in writing. In case of dissatisfaction with the results of the test, the producer or supplier may make claim for a rehearing.

## 17. Certification

**17.1** A producer's or supplier's certification shall be furnished to the purchaser that the material was manufactured, sampled, tested, and inspected in accordance with this specification and has been found to meet the requirements. When specified in the purchase order or contract, a report of the test results shall be furnished.

## 18. Product Marking

**18.1** Each bundle or box shall be properly tagged with metal tags showing heat number, grade, condition, specification number and size to assure proper identification.

## 19. Packaging and Package Marking

**19.1** Bars or wire shall be bundled or boxed in such a manner as to assure safe delivery to their destination when properly transported by any common carrier.

## 20. Keywords

**20.1** bar; UNS N08020; UNS N08024; UNS N08026; wire



# SPECIFICATION FOR ZIRCONIUM AND ZIRCONIUM ALLOY FORGINGS



**SB-493/SB-493M**



(Identical with ASTM Specification B493/B493M-14(2019).)

ASME NORMDOC.COM : Click to view the full PDF of ASME BPVC.II.B (ASME BPVC Section II part B) 2025

# Specification for Zirconium and Zirconium Alloy Forgings

## 1. Scope

1.1 This specification covers three grades of zirconium and zirconium alloy forgings (see 4.1).

1.2 The values stated in either SI units or inch-pound units are to be regarded separately as standard. The values stated in each system may not be exact equivalents; therefore, each system shall be used independently of the other. Combining values from the two systems may result in non-conformance with the standard.

1.3 The following safety hazards caveat pertains only to the test method portion, Section 12, of this specification: *This standard does not purport to address all of the safety concerns, if any, associated with its use. It is the responsibility of the user of this standard to establish appropriate safety, health, and environmental practices and determine the applicability of regulatory limitations prior to use.*

1.4 *This international standard was developed in accordance with internationally recognized principles on standardization established in the Decision on Principles for the Development of International Standards, Guides and Recommendations issued by the World Trade Organization Technical Barriers to Trade (TBT) Committee.*

## 2. Referenced Documents

2.1 *ASTM Standards:*  
E8/E8M Test Methods for Tension Testing of Metallic Materials

## 3. Terminology

3.1 *Lot Definition:*

3.1.1 *forgings, n*—parts, including semi-finished products, or complex shapes, produced by hot mechanical work using hammers, presses, or forging machines; a lot shall consist of a material of the same size, shape, condition, and finish produced from the same ingot or powder blend by the same reduction schedule and the same heat treatment parameters. Unless otherwise agreed between manufacturer and purchaser, a lot shall be limited to the product of an 8-h period for final continuous anneal, or to a single furnace load for final batch anneal.

## 4. Classification

- 4.1 The forgings are furnished in three grades as follows:
- 4.1.1 *Grade R60702*—Unalloyed zirconium.
  - 4.1.2 *Grade R60704*—Zirconium-tin alloy.
  - 4.1.3 *Grade R60705*—Zirconium-niobium alloy.

## 5. Ordering Information

5.1 Orders for material under this specification shall include the following information:

- 5.1.1 Quantity (weight and number of pieces),
- 5.1.2 Name of material (zirconium forgings),
- 5.1.3 Finish (Section 9),
- 5.1.4 Dimension (diameter, thickness, length, width, or as specified in appropriate drawings),
- 5.1.5 ASTM designation and year of issue,
- 5.1.6 Grade number (see 4.1), and
- 5.1.7 Additions to the specification and supplementary requirements, if required, including, but not limited to: product marking (see 17.1), check analysis (see 7.3), inspection (see 13.1), lot definition (see 3.1.1), internal soundness (see S1.1), and surface quality (see S2.1) requirements.

NOTE 1—A typical ordering description is as follows: 8000-lb zirconium forgings, mechanically descaled, 100 mm by 120 mm by 1.2 m rectangular bar, ASTM B493/B493M – 08, Grade R60702.

## 6. Materials and Manufacture

6.1 The forgings shall be formed with conventional forging equipment normally found in primary ferrous and nonferrous metal plants.

6.2 Forgings shall be furnished in the annealed conditions.

## 7. Chemical Composition

7.1 The material shall conform to the requirements as to chemical composition prescribed in Table 1.

TABLE 1 Chemical Requirements<sup>A</sup>

Element	Composition, %		
	UNS Grade Designation		
	R60702	R60704	R60705
Zirconium + hafnium, min <sup>B</sup>	99.2	97.5	95.5
Hafnium, max	4.5	4.5	4.5
Iron + chromium	0.2 max	0.2 to 0.4	0.2 max
Tin	...	1.0 to 2.0	...
Hydrogen, max	0.005	0.005	0.005
Nitrogen, max	0.025	0.025	0.025
Carbon, max	0.05	0.05	0.05
Niobium	...	...	2.0 to 3.0
Oxygen	0.16	0.18	0.18

<sup>A</sup> By agreement between the purchaser and the manufacturer, analysis may be required and limits established for elements and compounds not specified in the table of chemical composition.

<sup>B</sup> Zirconium is determined by difference.

TABLE 2 Permissible Variation in Check Analysis Between Different Laboratories

Element	Permissible Variation in Product Analysis, %
Hydrogen	0.002
Nitrogen	0.01
Carbon	0.01
Hafnium	0.1
Iron + chromium	0.025
Tin	0.05
Niobium	0.05
Oxygen	0.02

7.2 The manufacturer's ingot analysis shall be considered the chemical analysis for forgings, except for hydrogen and nitrogen, which shall be determined on the finished product.

7.3 When requested by the purchaser and stated in the purchase order, a check analysis for any elements listed in Table 1 shall be made on the finished product.

7.3.1 The manufacturer's analysis shall be considered as verified if the check analysis confirms the manufacturer's reported values within the tolerances prescribed in Table 2.

## 8. Workmanship and Quality Level Requirements

8.1 The material shall be free of injurious imperfections. Minor surface imperfections may be removed by spot grinding if such grinding does not reduce the dimensions of the finished piece below the minimum permitted by the tolerance for the product.

## 9. Finish and Appearance

9.1 The forgings shall have one of the following surface conditions as specified in the purchase order:

- 9.1.1 As forged,
- 9.1.2 Mechanically descaled, or
- 9.1.3 Mechanically descaled and pickled.

## 10. Tensile Requirements

10.1 The material, as represented by the test specimens, shall conform to the tensile properties prescribed in Table 3.

## 11. Number of Tests and Retests

- 11.1 Two tension tests shall be performed on each lot.

TABLE 3 Tensile Requirements

	UNS Grade Designation		
	R60702	R60704	R60705
Tensile strength, min, MPa [ksi]	380 [55]	415 [60]	485 [70]
Yield strength, min, MPa [ksi]	205 [30]	240 [35]	380 [55]
Elongation in 50 mm [2 in.], gauge min, % <sup>A</sup>	16	14	16

<sup>A</sup> When a sub-size specimen is used, the gauge length shall be as specified in Test Methods E8/E8M for that specimen.

11.2 Two chemistry tests for hydrogen and nitrogen content shall be performed on each lot of finished product.

### 11.3 Retests:

11.3.1 If any sample or specimen exhibits obvious surface contamination or improper preparation disqualifying it as a truly representative sample, it shall be discarded and a new sample or specimen substituted.

11.3.2 If the results of any tests of any lot do not conform to the requirements specified, retests shall be made on additional forgings of double the original number from the same lot, each of which shall conform to the requirements specified.

## 12. Test Methods

12.1 *Tension Tests*—Tension tests shall be performed in accordance with Test Methods E8/E8M. Determine the yield strength by the offset (0.2 %) method. Determine the tensile properties using a strain rate of 0.003 to 0.007 mm/mm/min [in./in./min] through the yield strength. After the yield strength has been exceeded, increase the cross-head speed to approximately 0.05 mm/mm/min [in./in./min] to failure.

12.2 *Chemical Tests*—The chemical analyses shall be performed according to the standard techniques normally used by the manufacturer.

## 13. Inspection

13.1 The manufacturer shall inspect the material covered by this specification prior to shipment. If so specified in the purchase order, the purchaser or his representative may witness the testing and inspection of the material at the place of manufacture. In such cases, the purchaser shall state in his purchase order which tests he desires to witness. The manufacturer shall give ample notice to the purchaser as to the time and place of the designated tests. If the purchaser's representative does not present himself at the time agreed upon for the testing, the manufacturer shall consider the requirement for the purchaser's inspection at the place of manufacture to be waived.

13.2 The manufacturer shall afford the inspector representing the purchaser, without charge, all reasonable facilities to satisfy him that the material is being furnished in accordance with this specification. This inspection shall be so conducted as not to interfere unnecessarily with the operation of the works.

## 14. Rejection and Rehearing

14.1 Material that fails to conform to the requirements of this specification may be rejected. Rejection should be reported to the producer or supplier promptly and in writing. In case of

dissatisfaction with the results of the test, the producer or supplier may make claim for a rehearing.

#### 15. Certification

15.1 A producer's or supplier's certification shall be furnished to the purchaser certifying that the material was manufactured, sampled, tested, and inspected in accordance with this specification and has been found to meet the requirements. A report of the test results shall be included as part of the certification.

#### 16. Referee

16.1 In the event of disagreement between the manufacturer and the purchaser on the conformance of the material to the requirements of this specification or any special test specified by the purchaser, a mutually acceptable referee shall perform the tests in question. The results of the referee's testing shall be used in determining conformance of the material to this specification.

#### 17. Product Marking

17.1 Unless otherwise specified, each forging over 1 kg [2 lb], manufactured in accordance with this specification, shall be marked legibly, either by stenciling, stamping, or rolling with the manufacturer's private identification mark, the ASTM designation, the grade, and lot number. On smaller than 1 kg [2 lb] forgings, the same information shall be stamped legibly on the container, or on a metal tag securely fastened to each part or package of parts.

#### 18. Packaging and Package Marking

18.1 The forgings shall be packaged either in a suitable box or banded on a skid.

#### 19. Keywords

19.1 zirconium; zirconium alloy forging

### SUPPLEMENTARY REQUIREMENTS

#### S1. Special Internal Soundness

S1.1 Forging shall be produced with specified internal soundness to be verified by electric test or radiography to standards agreed upon between the manufacturer and the purchaser prior to the acceptance of the order.

#### S2. Surface Quality

S2.1 The surface quality shall be as agreed upon between the manufacturer and the purchaser.

## SPECIFICATION FOR CASTINGS, NICKEL AND NICKEL ALLOY



**SA-494/SA-494M**

(Identical with ASTM Specification A494/A494M-15 except that certification has been made mandatory, UNS Numbers corrected for Grades M35-2, N3M, and N7M in Table 1, and E1473 replaces E30, E38, and E76 in paras. 2.1 and 7.3.)

# Specification for Castings, Nickel and Nickel Alloy

## 1. Scope

1.1 This specification covers nickel, nickel-copper, nickel-copper-silicon, nickel-molybdenum, nickel-chromium, and nickel-molybdenum-chromium alloy castings for corrosion-resistant service.

1.2 The values stated in either SI units or inch-pound units are to be regarded separately as standard. The values stated in each system may not be exact equivalents; therefore, each system shall be used independently of the other. Combining values from the two systems may result in non-conformance with the standard.

## 2. Referenced Documents

### 2.1 ASTM Standards:

A370 Test Methods and Definitions for Mechanical Testing of Steel Products

A488/A488M Practice for Steel Castings, Welding, Qualifications of Procedures and Personnel

A732/A732M Specification for Castings, Investment, Carbon and Low Alloy Steel for General Application, and Cobalt Alloy for High Strength at Elevated Temperatures

A781/A781M Specification for Castings, Steel and Alloy, Common Requirements, for General Industrial Use

A957/A957M Specification for Investment Castings, Steel and Alloy, Common Requirements, for General Industrial Use

E8 Test Methods for Tension Testing of Metallic Materials

E29 Practice for Using Significant Digits in Test Data to Determine Conformance with Specifications

E1473 Test Methods for Chemical Analysis of Nickel, Cobalt and High Temperature Alloys

E354 Test Methods for Chemical Analysis of High-Temperature, Electrical, Magnetic, and Other Similar Iron, Nickel, and Cobalt Alloys

## 3. Terminology

### 3.1 Definitions:

3.1.1 *master heat*—a single furnace charge of refined alloy, which may either be poured directly into castings or into remelt alloy for individual melts.

3.1.2 *melts*—a single furnace charge poured into castings. When master heats are used to prepare melts, a melt analysis shall be reported.

## 4. General Conditions for Delivery

4.1 Except for investment castings, castings furnished to this specification shall conform to the requirements of Specification A781/A781M, including any supplementary requirements that are indicated on the purchase order. Failure to comply with the general requirements of Specification A781/A781M constitutes nonconformance with this specification. In case of conflict between the requirements of this specification and Specification A781/A781M, this specification shall prevail.

4.2 Investment castings furnished to this specification shall conform to the requirements of Specification A957/A957M, including any supplementary requirements that are indicated in the purchase order. Failure to comply with the general requirements of Specification A957/A957M constitutes nonconformance with this specification. In case of conflict between the requirements of this specification and Specification A957/A957M, Specification A957/A957M shall prevail.

## 5. Ordering Information

5.1 Orders for castings to this specification should include the following information:

5.1.1 Quantity, in pieces, and

5.1.2 Grade designation (Table 1) and class (Table 2).

TABLE 1 Chemical Requirements

NOTE 1—Values are maximum unless otherwise indicated.

Alloy Family	Ni	Ni-Cu					Ni-Mo			Ni-Cr								Other
Grade	CZ100	M25S	M30C <sup>A</sup>	M30H	M35-1 <sup>A</sup>	M35-2	N3M	N7M	N12MV	CU5MCuC	CW2M	CW6M	CW6MC	CW12MW	CX2M	CX2MW	CY40	CY5SnBiM
UNS Numbers	N02100	N24025	N24130	N24030	N24135	N04020	N30003	N30007	N30012	N08826	N26455	N30107	N26625	N30002	N26059	N26022	N06040	N26055
Composition, %																		
C	1.00	0.25	0.30	0.30	0.35	0.35	0.03	0.07	0.12	0.050	0.02	0.07	0.06	0.12	0.02	0.02	0.40	0.05
Mn	1.50	1.50	1.50	1.50	1.50	1.50	1.00	1.00	1.00	1.0	1.00	1.00	1.00	1.00	1.00	1.00	1.50	1.5
Si	2.00	3.5-4.5	1.0-2.0	2.7-3.7	1.25	2.00	0.50	1.00	1.00	1.0	0.80	1.00	1.00	1.00	0.50	0.80	3.00	0.5
P	0.03	0.03	0.03	0.03	0.03	0.03	0.030	0.030	0.030	0.030	0.03	0.030	0.015	0.030	0.020	0.025	0.03	0.03
S	0.02	0.02	0.02	0.02	0.02	0.02	0.020	0.020	0.020	0.020	0.02	0.020	0.015	0.020	0.020	0.020	0.02	0.02
Cu	1.25	27.0-33.0	26.0-33.0	27.0-33.0	26.0-33.0	26.0-33.0	...	...	...	1.50-3.50	<sup>B</sup>	<sup>B</sup>	<sup>B</sup>	<sup>B</sup>	<sup>B</sup>	<sup>B</sup>	<sup>B</sup>	...
Mo	...	...	...	...	...	...	30.0-33.0	30.0-33.0	26.0-30.0	2.5-3.5	15.0-17.5	17.0-20.0	8.0-10.0	16.0-18.0	15.0-16.5	12.5-14.5	<sup>B</sup>	2.0-3.5
Fe	3.00	3.50	3.50	3.50	3.50	3.50	3.00	3.00	4.0-6.0	balance	2.0	3.0	5.0	4.5-7.5	1.50	2.0-6.0	11.0	2.0
Ni	95.00 min	balance	balance	balance	balance	balance	balance	balance	balance	38.0-44.0	balance	balance	balance	balance	balance	balance	balance	balance
Cr	...	...	...	...	...	...	1.0	1.0	1.00	19.5-23.5	15.0-17.5	17.0-20.0	20.0-23.0	15.5-17.5	22.0-24.0	20.0-22.5	14.0-17.0	11.0-14.0
Cb (Nb)	...	<sup>B</sup>	1.0-3.0	<sup>B</sup>	0.5	0.5	...	...	...	0.60-1.20	<sup>B</sup>	<sup>B</sup>	3.15-4.50	<sup>B</sup>	<sup>B</sup>	<sup>B</sup>	<sup>B</sup>	...
W	...	...	...	...	...	...	...	...	...	<sup>B</sup>	1.0	<sup>B</sup>	<sup>B</sup>	3.75-5.25	<sup>B</sup>	2.5-3.5	<sup>B</sup>	...
V	...	...	...	...	...	...	<sup>B</sup>	<sup>B</sup>	0.20-0.60	<sup>B</sup>	<sup>B</sup>	<sup>B</sup>	<sup>B</sup>	0.20-0.40	<sup>B</sup>	0.35	<sup>B</sup>	...
Bi	...	...	...	...	...	...	...	...	...	...	...	...	...	...	...	...	...	3.0-5.0
Sn	...	...	...	...	...	...	...	...	...	...	...	...	...	...	...	...	...	3.0-5.0

<sup>A</sup> Order M35-1 or M30C when weldability is required.

<sup>B</sup> Element to be analyzed and reported for information only.

TABLE 2 Heat-Treat Requirements

Grade	Heat Treatment
CZ100, M35-1, M35-2, CY40 Class 1, M30H, M30C, M25S Class 1, CY5SnBiM M25S, Class 2 <sup>A</sup>	As cast  Load into furnace at 600°F [315°C] maximum. Heat to 1600°F [870°C] and hold for 1 h plus an additional 30 min for each ½ in. [13 mm] of cross section over 1 in. <sup>B</sup> Cool to 1300°F [705°C] <sup>C</sup> and hold at temperature for 30 min then quench in oil to room temperature.
M25S, Class 3	Load into furnace at 600°F [315°C] maximum. Heat slowly to 1100°F [605°C] and hold to develop maximum hardness. Furnace or air cool to room temperature.
N12MV, N7M, N3M	Heat to 2000°F [1095°C] minimum, hold for sufficient time to heat castings to temperature, quench in water or rapid cool by other means.
CW12MW, CW6M, CW6MC, CW2M	Heat to 2150°F [1175°C] minimum, hold for sufficient time to heat castings to temperature, quench in water or rapid cool by other means.
CY40, Class 2	Heat to 1900°F [1040°C] minimum, hold for sufficient time to heat castings to temperature, quench in water or rapid cool by other means.
CX2MW	Heat to 2200°F [1205°C] minimum, hold for sufficient time to heat castings to temperature, quench in water or rapid air cool by other means.
CU5MCuC	Heat to 2100°F [1150°C] minimum, hold for sufficient time to heat castings to temperature, quench in water. Stabilize at 1725-1815°F [940-990°C], hold for sufficient time to heat castings to temperature, quench in water or rapid cool by other means.
CX2M	Heat to 2100°F [1150°C] minimum, hold for sufficient time to heat castings to temperature, quench in water or rapid air cool by other means.

<sup>A</sup> M25S, while machinable in the “as-cast” condition, is capable of being solution heat-treated for improved machinability. It may be subsequently age hardened to the hardness specified in Table 3 and finished machined or ground.

<sup>B</sup> For cross sections over 6 in. [125 mm], it may be necessary to increase the hold time if maximum softness is desired.

<sup>C</sup> For maximum softness and the least variation in hardness levels, castings should be transferred from an oven at 1600°F [870°C] to a second oven at 1300°F [705°C].

5.2 The purchaser shall specify any of the following information required to describe adequately the desired material:

5.2.1 Heat-treat condition (see 6.1 and 6.2),

5.2.2 Repair welding (see Section 11)

5.2.3 Source inspection requirements, if any (see Specification A781/A781M),

5.2.4 Marking-for-identification requirements, if any (see 13.1), and

5.2.5 Supplementary requirements desired, including the standards of acceptance.

## 6. Heat Treatment

6.1 Castings shall be heat-treated in accordance with the requirements in Table 2.

NOTE 1—Proper heat treatment of these alloys is usually necessary to enhance corrosion resistance and, in some cases, to meet mechanical properties. Minimum heat-treat temperatures are specified; however, it is sometimes necessary to heat-treat at higher temperatures, hold for some minimum time at temperature, and then rapidly cool the castings in order to enhance the corrosion resistance and meet mechanical properties.

6.2 When Class 1 is specified, grades CY40 and M25S shall be supplied in the as-cast condition. When Class 2 is specified, grades CY40 and M25S shall be supplied in the solution heat-treated condition. When Class 3 is specified, grade M25S shall be supplied in the age-hardened condition.

## 7. Chemical Composition

7.1 These alloys shall conform to the chemical composition requirements prescribed in Table 1.

7.2 The grades that pertain to this specification are placed into the five general categories given below. The producer shall report for information all elements in Table 1 for which a limit is given for any alloy in the same alloy family. The alloy families are:

(1) Nickel – CZ100

(2) Nickel-copper – M35-1, M35-2, M30C, M30H, M25S

(3) Nickel-molybdenum – N12MV, N7M, N3M

(4) Nickel-chromium – CY40, CW6M, CW2M, CW6MC, CX2MW, CU5MCuC, CX2M

(5) Other – CY5SnBiM

7.3 An analysis of each master heat shall be made by the manufacturer to determine the percentages of the elements specified in Table 1. The analysis shall be made from a representative sample taken during the pouring of the master heat. Chemical composition shall be reported to the purchaser or his representative.

7.4 Test Methods E1473 or Test Methods E354 shall be used for referee purposes.

## 8. Tensile Properties

8.1 One tension test shall be made from each master heat except for grades M25S and CY5SnBiM when the master heat is used to pour the castings. One tension test shall be made from each melt except for grades M25S and CY5SnBiM. Test results shall conform to the tensile requirements specified in Table 3. Test bars shall be poured in special blocks from the same heat as the castings represented.

8.2 The bar from which the test specimen is taken shall be heat-treated in production furnaces to the same procedure as the castings it represents. If the castings are not heat-treated, the bar used for the test specimen must not be heat-treated.

8.3 Test specimens may be cut from castings, at the producer's option, instead of from test bars.

8.4 When castings are produced by methods other than investment process, tension test coupons shall be machined to

TABLE 3 Mechanical Properties

Alloy Family	Ni		Ni-Cu				Ni-Mo			Ni-Cr							Other	
	CZ100	M25S	M30C	M30H	M35-1	M35-2	N3M	N7M	N12MV	CU5-MCuC	CW2M	CW6M	CW6MC	CW-12MW	CX2M	CX2MW	CY40	CY5SnBiM
Tensile strength, min, ksi [MPa]	50 [345]	...	65 [450]	100 [690]	65 [450]	65 [450]	76 [525]	76 [525]	76 [525]	75 [520]	72 [495]	72 [495]	70 [485]	72 [495]	72 [495]	80 [550]	70 [485]	...
Yield strength, min, ksi [MPa]	18 [125]	...	32.5 [225]	60 [415]	25 [170]	30 [205]	40 [275]	40 [275]	40 [275]	35 [240]	40 [275]	40 [275]	40 [275]	40 [275]	39 [270]	45 [310]	28 [195]	...
Elongation in 2 in. [50 mm], <sup>A</sup> min, %	10	...	25	10	25	25	20.0	20	6	20	20	25	25	4	40	30	30	...
Hardness HBW	...	<sup>B</sup>	...	...	...	...	...	...	...	...	...	...	...	...	...	...	...	...

<sup>A</sup> When ICI test bars are used in tensile testing as provided for in Specification A732/A732M, the gage length to reduced section diameter ratio shall be 4 to 1.

<sup>B</sup> 300 HBW minimum for the age hardened condition.

the form and dimension shown in Fig. 8 of, and tested in accordance with, Test Methods E8.

8.4.1 When castings are produced by the investment process, test specimens in accordance with Specification A732/A732M shall be used for measurement of tensile properties.

8.5 If any specimen shows defective machining or develops flaws, it may be discarded and another substituted from the same heats.

8.6 To determine conformance with the tension test requirements, an observed value or calculated value shall be rounded in accordance with the "Rounding Method" of Practice E29 to the nearest 0.5 ksi [5 MPa] for yield and tensile strength and to the nearest 1 % for elongation and reduction of area. In the special case of rounding the number "5" when no additional numbers other than "0" follow the "5," rounding shall be done in the direction of the specification limits if following Practice E29 would cause rejection of material.

## 9. Workmanship, Finish, and Appearance

9.1 Critical surfaces of all castings intended for corrosion-resistant service shall be cleaned. Cleaning may be accomplished by blasting with clean sand or metallic corrosion-resistant shot or by other approved methods.

## 10. Quality

10.1 The castings shall not be peened, plugged, or impregnated to stop leaks.

10.2 Internal chills and chaplets may be used in the manufacture of castings. However, the chills, chaplets and affected cast material must be completely removed.

## 11. Repair by Welding

11.1 Repairs shall be made by using a welding procedure and operators capable of producing sound welds. The composition of deposited weld metal shall be similar to that of the castings.

11.2 Weld repairs shall be considered major in the case of a casting that has leaked on hydrostatic test or when the depth of the cavity after preparation for repair exceeds 20 % of the actual wall thickness, or 1 in. [25 mm], whichever is smaller, or when the extent of the cavity exceeds approximately 10 in.<sup>2</sup> [65 cm<sup>2</sup>]. All other weld repairs shall be considered minor. Major and minor weld repairs shall be subject to the same quality standards as are used to inspect the castings.

11.3 Castings of M30H, M25S, and CY5SnBiM may not be weld repaired.

11.4 Grades N12MV, N7M, N3M, CW12MW, CW6M, CW2M, CX2MW, CX2M, CW6MC, and CU5MCuC may require post-weld heat treatment after major weld repairs. If post-weld heat treatment is required, it must be specified along with the grade. If required, it shall be performed in accordance with Section 6.

11.5 For grade CU5MCuC, the composition of the deposited weld metal shall be similar to that of AWS A5.14 ER NiCrMo3 or AWS A5.11 E NiCrMo3.

## 12. Rejection and Rehearing

12.1 Samples that represent rejected material shall be preserved for two weeks from the date of transmission of the rejection report. In case of dissatisfaction with the results of the tests, the manufacturer may make claim for a rehearing within that time.

## 13. Certification

13.1 A manufacturer's certification shall be furnished to the purchaser stating that the material has been manufactured, tested, and inspected in accordance with this specification, and that the test results on representative samples meet specification requirements. A report of the test results shall be furnished.

## 14. Product Marking

14.1 Castings shall be marked for the material identification with the ASTM specification designation (A494/A494M) and grade symbol, that is, CY40. The manufacturer's name or identification mark and the pattern number shall be cast or stamped on all castings except those of such small size as to make such marking impractical. To minimize small defects caused by dislodged particles of molding sand, the number of cast identification marks shall be minimized. The marking of heat numbers on individual castings shall be agreed upon by the manufacturer and the purchaser. Markings shall be in such position as not to injure the usefulness of the casting.

14.1.1 When the castings are too small to mark individually, a symbol traceable to the heat shall be placed on the castings and the required identification then placed on a tag affixed to the container in which these castings are shipped.

## 15. Keywords

15.1 corrosion-resistant applications; nickel; nickel alloy castings; nickel alloys; nickel castings

## SUPPLEMENTARY REQUIREMENTS

The following supplementary requirements shall not apply unless specified in the purchase order. A list of standard supplementary requirements for use at the option of the purchaser is included in Specifications A781/A781M and A957/A957M. Those which are ordinarily considered for use with this specification are given below; others enumerated in Specifications A781/A781M and A957/A957M may be used with this specification upon agreement between the manufacturer and the purchaser.

### S2. Radiographic Examination

### S3. Liquid Penetrant Examination

### S6. Certification

### S10. Hardness Tests

S10.1 When composition M25S material is ordered with a hardness maximum or range in the as-cast or solution heat-treated condition, hardness tests shall be made in accordance with Test Methods and Definitions A370. The test location, number of tests, and hardness values shall be agreed upon between the manufacturer and purchaser.

S10.1.1 If castings are ordered in the as-cast condition, hardness determinations shall be made on two different representative areas of each casting or coupon selected for test.

S10.1.1.1 By agreement between purchaser and producer, those as-cast castings that fail to meet the required hardness may be accepted in the solution heat-treated and hardened condition if the hardness thus developed meets the hardness requirement of the specification.

S10.1.2 If castings ordered are in the solution heat-treated condition, two sample castings or two coupons representing the lot shall be heat-treated for tests (see S10.1.1). Hardness determinations shall be made on two different representative areas of each casting or coupon.

S10.1.3 When hardness tests are made, the specimens shall be at least  $\frac{1}{4}$  in. [6 mm] in thickness and the area to be tested shall be ground clean before the hardness tests are made.

### S50. Weldability Test

S50.1 If weldability tests are specified for M30C or M35-1, prepare a coupon obtained from a test bar shown in Fig. S50.1 or Fig. S50.2 for each lot of composition M30C or M35-1 castings. The weld test to be used shall be agreed upon between the purchaser and manufacturer.

S50.1.1 Prepare and weld the test bar cast in accordance with Fig. S50.1 and in accordance with Fig. S50.3.

S50.1.1.1 Machine the cast skin and unsound metal from two adjacent faces of the as-cast specimen, exclude the riser face, and cut the specimen into approximately 6-in. [150-mm] lengths.

S50.1.1.2 Clamp the two 6-in. [150 mm] lengths together to form a double V-joint and weld two passes at a time on alternate sides of the specimen using  $\frac{1}{8}$ -in. [3-mm] diameter electrodes that will deposit metal of similar composition of the test pieces.

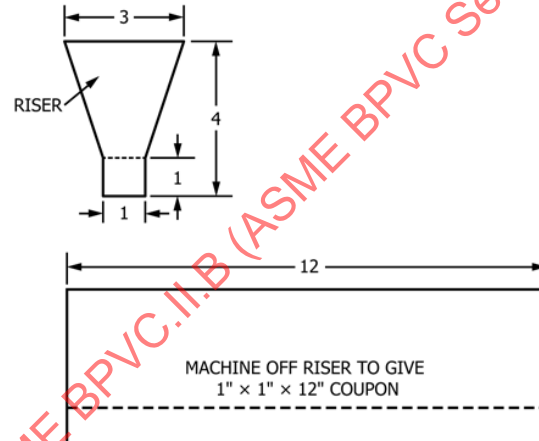

Metric Equivalents				
in.	1	3	4	12
[mm]	[25]	[75]	[100]	[305]

NOTE 1—Riser shall be machined off and 1 in. [25 mm] square by 12 in. [305 mm] coupon shall be used for x-weld test. See Fig. S50.3.

FIG. S50.1 Weld Test Bar (As Cast)

S50.1.1.3 Allow the specimen to cool to room temperature between passes, remove all flux, and examine visually for cracks.

S50.1.1.4 The clamps may be removed from the specimen after the first two weld passes have been completed.

S50.1.1.5 Deposit alternate series of passes until the double V-groove has been completely filled. After the second series (number 4 pass) a  $\frac{5}{32}$ -in. [4-mm] diameter electrode may be used if desired.

S50.1.1.6 During welding allow each pass to cool, clean, and examine visually for cracks. The presence of cracks shall be cause for rejection.

S50.1.1.7 Upon completion of the welding, cut one section approximately  $\frac{3}{4}$  in. [19 mm] long transverse to the weld from each end and discard.

S50.1.1.8 Polish each end of the remaining center section on a 100/200-grit wheel and etch with concentrated  $\text{HNO}_3$  or with Lepito's etchant. Prepare Lepito's etchant as follows: (1) 15 g of  $(\text{NH}_4)_2\text{SO}_4$  dissolved in 75  $\text{cm}^3$  of water; (2) 250 g of  $\text{FeCl}_3$  (powdered) dissolved in 100  $\text{cm}^3$  of  $\text{HCl}$ ; (3) mix solutions (1) and (2) and add 30  $\text{cm}^3$  of  $\text{HNO}_3$ .

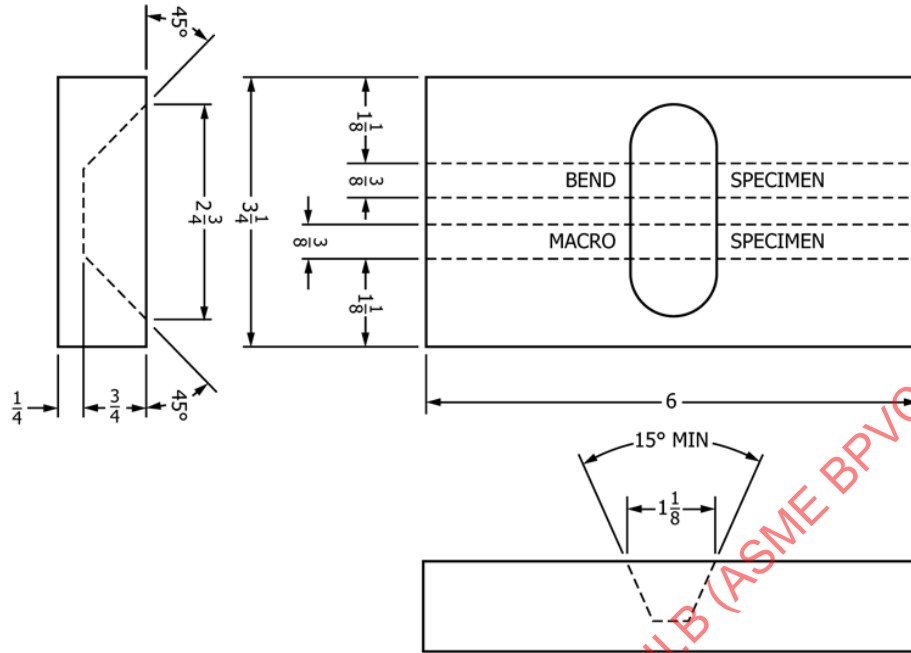

Metric Equivalents							
in.	1/4	3/8	3/4	1 1/8	2 3/4	3 1/4	6
[mm]	[5]	[10]	[20]	[30]	[70]	[85]	[155]

FIG. S50.2 Weld Test Bar (As Cast)

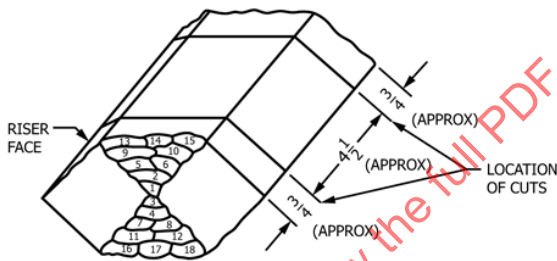

Metric Equivalents		
in.	3/4	4 1/2
[mm]	[20]	[115]

FIG. S50.3 X-Weld Test

S50.1.1.9 Examine the etched section under low magnification (5 to 10x). The lot represented by the test specimen shall be accepted if it complies with the following crack requirements: (1) Three cracks maximum in linear inch of base metal and (2) the length of any crack in the base metal does not exceed 0.20 in. [5 mm].

S50.1.1.10 Cracks observed in the weld metal during the low-magnification examination shall not be cause for rejection.

S50.1.1.11 Failure of welded test bars to comply with any of the requirements S50.1 through S50.1.1.10 shall result in rejection of the lot represented.

S50.1.2 Prepare and weld the test bar cast in accordance with Fig. S50.2 as follows:

S50.1.2.1 Fill the groove in the block completely with weld deposit using manual metallic arc process with 1/8-in. [3.2-mm] or 5/32-in. [4-mm] diameter electrodes that will deposit metal of similar composition of the test piece.

S50.1.2.2 Remove one 3/8-in. [10-mm] thick bend coupon longitudinally from the welded block by machining, sawing, abrasive cutting, or other suitable means. Make a transverse side bend test of the welded joint in accordance with Practice A488/A488M.

S50.1.2.3 Remove a transverse weld macro-specimen from the welded plate and visually examine for cracks. This specimen may be the same one to be used for the bend specimen.

S50.1.3 Acceptance:

S50.1.3.1 Cracks as tears in the casting in the fusion zone or heat-affected zone of the macro-specimen shall be cause for rejection. Cracks originating at the weld bead undercuts, at weld slag inclusions, or at casting defects shall not be cause for rejection.

S50.1.3.2 Cracks or other open defects exceeding 1/8-in. [3.2 mm] measured in any direction on the convex surface of the bent specimens shall be cause for rejection, except that cracks occurring on the corners while testing and cracks originating at weld bead undercuts shall not be considered.

ASMENORMDOC.COM : Click to view the full PDF of ASME BPVC.II.B (ASME BPVC Section II part B) 2025

INTENTIONALLY LEFT BLANK

## SPECIFICATION FOR COPPER ALLOY CONTINUOUS CASTINGS



**SB-505/SB-505M**



(25)

(Identical with ASTM Specification B505/B505M-22 except that certification, marking, test reports, and conformance to mechanical properties have been made mandatory.)

*ASME SB-505/SB-505M replaces paras. 5.1.9, 5.2.2, 5.2.4, 5.2.5, 5.2.6, 6.1, 8.2, 9.1, 9.1.4, 12.4, 12.5, and 14.1 of ASTM B505/B505M with the following:*

5.1.9 DELETED

5.2.2 DELETED

5.2.4 DELETED

5.2.5 DELETED

5.2.6 DELETED

6.1 For better corrosion resistance in seawater applications, castings in Copper Alloy UNS No. C95800 shall be given a temperature anneal heat treatment at  $1250^{\circ}\text{F} \pm 50^{\circ}\text{F}$  [ $675^{\circ}\text{C} \pm 28^{\circ}\text{C}$ ] for 6 h minimum. Cooling shall be by the fastest means possible that will not cause excessive distortion or cracking. Propeller castings shall be exempt from this requirement.

8.2 DELETED

9.1 Continuous castings shall comply with the following:

9.1.4 When Copper Alloy UNS No. C95200 is specified, a sample from each 2000 lb interval or continuous casting shall be tested. Each continuous casting from which the test bar was taken shall be identified should retesting be required. If all of the test bars from the initial sampling meet the requirements, the lot shall be acceptable. The fractured bars shall be retained for chemical verification.

12.4 One sample for tension testing shall be taken from each lot. This sample may be taken before mechanical straightening. Test bar specimens shall be positively identified with the castings they represent. Where castings are heat treated, test bar specimens shall be heat treated with the castings they represent.

12.5 When Copper Alloy UNS No. C95200 is specified, a sample from each 2000 lb interval or continuous casting shall be tested. Each continuous cast bar from which the test bar was taken shall be identified should retesting be required. If all of the test bars from the initial sampling meet the requirements, the lot shall be acceptable.

14.1 DELETED

ASMENORMDOC.COM : Click to view the full PDF of ASME BPVC.II.B (ASME BPVC Section II part B) 2025



Designation: B505/B505M – 22

## Standard Specification for Copper Alloy Continuous Castings<sup>1</sup>

This standard is issued under the fixed designation B505/B505M; the number immediately following the designation indicates the year of original adoption or, in the case of revision, the year of last revision. A number in parentheses indicates the year of last reapproval. A superscript epsilon ( $\epsilon$ ) indicates an editorial change since the last revision or reapproval.

*This standard has been approved for use by agencies of the U.S. Department of Defense.*

### 1. Scope\*

1.1 This specification establishes requirements for continuously cast rod, bar, tube, and shapes produced from copper alloys with nominal compositions as listed in Table 1.<sup>2</sup>

1.2 Castings produced to this specification may be manufactured for and supplied from stock. In such cases the manufacturer shall maintain heat traceability to specific manufacturing date and chemical analysis.

1.3 The values stated in either SI units or inch-pound units are to be regarded separately as standard. The values stated in each system may not be exact equivalents; therefore, each system shall be used independently of the other. Combining values from the two systems may result in non-conformance with the standard.

1.4 *This standard does not purport to address all of the safety concerns, if any, associated with its use. It is the responsibility of the user of this standard to establish appropriate safety, health, and environmental practices and determine the applicability of regulatory limitations prior to use.*

1.5 *This international standard was developed in accordance with internationally recognized principles on standardization established in the Decision on Principles for the Development of International Standards, Guides and Recommendations issued by the World Trade Organization Technical Barriers to Trade (TBT) Committee.*

### 2. Referenced Documents

#### 2.1 ASTM Standards:<sup>3</sup>

B208 Practice for Preparing Tension Test Specimens for Copper Alloy Sand, Permanent Mold, Centrifugal, and Continuous Castings  
B824 Specification for General Requirements for Copper Alloy Castings  
B846 Terminology for Copper and Copper Alloys  
E8/E8M Test Methods for Tension Testing of Metallic Materials  
E10 Test Method for Brinell Hardness of Metallic Materials  
E18 Test Methods for Rockwell Hardness of Metallic Materials  
E255 Practice for Sampling Copper and Copper Alloys for the Determination of Chemical Composition  
E527 Practice for Numbering Metals and Alloys in the Unified Numbering System (UNS)

#### 2.2 Other Standard:<sup>4</sup>

ASME Boiler and Pressure Vessel Code

### 3. Terminology

3.1 For definitions of terms related to copper and copper alloys, refer to Terminology B846.

### 4. General Requirements

4.1 The following sections of Specification B824 form a part of this specification. The definition of a casting lot as defined in Section 12, Sampling, takes precedence over Specification B824.

4.1.1 Terminology (Section 3),  
4.1.2 Other Requirements (Section 7),  
4.1.3 Workmanship, Finish, and Appearance (Section 9),  
4.1.4 Number of Tests and Retests (Section 11),  
4.1.5 Specimen Preparation (Section 12),  
4.1.6 Test Methods (Section 13),  
4.1.7 Significance of Numerical Limits (Section 14),  
4.1.8 Inspection (Section 15),  
4.1.9 Rejection and Rehearing (Section 16),  
4.1.10 Certification (Section 17),  
4.1.11 Test Report (Section 18),  
4.1.12 Product Marking (Section 19),

<sup>1</sup> This specification is under the jurisdiction of ASTM Committee B05 on Copper and Copper Alloys and is the direct responsibility of Subcommittee B05.05 on Castings and Ingots for Remelting.

Current edition approved Oct. 1, 2022. Published October 2022. Originally approved in 1970. Last previous edition approved in 2018 as B505/B505M – 18. DOI: 10.1520/B0505\_B0505M-22.

<sup>2</sup> The UNS system for copper and copper alloys (see Practice E527) is a simple expansion of the former standard designation system accomplished by the addition of a prefix “C” and a suffix “00.” The suffix can be used to accommodate composition variations of the base alloy.

<sup>3</sup> For referenced ASTM standards, visit the ASTM website, [www.astm.org](http://www.astm.org), or contact ASTM Customer Service at [service@astm.org](mailto:service@astm.org). For *Annual Book of ASTM Standards* volume information, refer to the standard’s Document Summary page on the ASTM website.

<sup>4</sup> Available from American Society of Mechanical Engineers (ASME), ASME International Headquarters, Two Park Ave., New York, NY 10016-5990, <http://www.asme.org>.

TABLE 1 Nominal Composition

Copper Alloy UNS No.	Designation	Composition, %											
		Copper	Tin	Lead	Zinc	Nickel	Aluminum	Iron	Manganese	Silicon	Phosphorus	Bismuth	Sulfur
C83470	low-lead sulfur tin bronze	93	4	...	2	0.5	...	...	...	...	...	...	0.5
C83600	leaded red brass	85	5	5	5	...	...	...	...	...	...	...	...
C83800	leaded red brass	82.9	3.8	6	6.5	...	...	...	...	...	...	...	...
C84200	leaded semi-red brass	80	5	2.5	13	...	...	...	...	...	...	...	...
C84400	leaded semi-red brass	80	2.9	7	8.5	...	...	...	...	...	...	...	...
C84800	leaded semi-red brass	76	2.5	6.2	15	...	...	...	...	...	...	...	...
C85470	yellow brass	62.5	2.5	...	34.3	...	0.5	...	...	...	0.13	...	...
C85700	leaded naval brass	61	1	1.2	36	...	...	...	...	...	...	...	...
C86200	high-strength yellow brass	63	...	...	25	...	4	3	3.8	...	...	...	...
C86300	high-strength yellow brass	63	...	...	25	...	6.2	3	3.8	...	...	...	...
C86500	high-strength yellow brass	57.5	...	...	39	...	1	1.2	0.8	...	...	...	...
C87700	silicon bronze	88.5	...	...	8	...	...	...	...	3	...	...	...
C87710	silicon bronze	86	...	...	10	...	...	...	...	4	...	...	...
C87850	silicon brass	76	...	...	20.9	...	...	...	...	3	0.12	...	...
C89320	bismuth tin bronze	89	6	...	...	...	...	...	...	...	...	5.0	...
C89545	bismuth brass	69.0	...	...	29.0	0.5	1.0	...	...	...	0.08	0.55	...
C89720 <sup>A</sup>	bismuth brass	67.4	1	...	29	...	0.5	...	...	0.5	...	1.5	...
C89838	bismuth brass	81.5	2.75	...	15.0	...	...	...	...	...	...	0.55	...
C89845	bismuth semi-red brass	85.0	4.0	...	7.5	2.0	...	...	...	...	...	1.5	...
C90300	tin bronze	87.5	8.2	...	4	...	...	...	...	...	...	...	...
C90500	tin bronze	87.5	10	...	2	...	...	...	...	...	...	...	...
C90700	tin bronze	89	11	...	...	...	...	...	...	...	...	...	...
C91000	tin bronze	85	15	...	...	...	...	...	...	...	...	...	...
C91300	tin bronze	80.5	19	...	...	...	...	...	...	...	...	...	...
C92200	leaded tin bronze	88	6	1.5	4	...	...	...	...	...	...	...	...
C92300	leaded tin bronze	87	8.2	0.6	3.8	...	...	...	...	...	...	...	...
C92500	nickel-phosphor bronze	86.5	11	1.2	...	1.2	...	...	...	...	...	...	...
C92700	leaded tin bronze	87.5	10	1.8	...	...	...	...	...	...	...	...	...
C92800	leaded tin bronze	80	16	5	...	...	...	...	...	...	...	...	...
C92900	leaded nickel-tin bronze	84	10	2.6	...	3.4	...	...	...	...	...	...	...
C93200	high-leaded tin bronze	83	6.9	7	3	...	...	...	...	...	...	...	...
C93400	high-leaded tin bronze	83.5	8	8	...	...	...	...	...	...	...	...	...
C93500	high-leaded tin bronze	84.5	5.2	9	1	...	...	...	...	...	...	...	...
C93600	high-leaded tin bronze	81	7	12	...	...	...	...	...	...	...	...	...
C93700	high-leaded tin bronze	80	10	9.5	...	...	...	...	...	...	...	...	...
C93800	high-leaded tin bronze	77	6.9	14.5	...	...	...	...	...	...	...	...	...
C93900	high-leaded tin bronze	78	6	16	...	...	...	...	...	...	...	...	...
C94000	high-leaded tin bronze	70.5	13	15	...	...	...	...	...	...	...	...	...
C94100	high-leaded tin bronze	75.5	5.5	20	...	...	...	...	...	...	...	...	...
C94300	high-leaded tin bronze	69.5	5.2	25	...	...	...	...	...	...	...	...	...
C94700	nickel-tin bronze	87.5	5.2	0	1.8	5.2	...	...	...	...	...	...	...
C94800	leaded nickel-tin bronze	86.5	5.2	0.6	1.8	5.2	...	...	...	...	...	...	...
C95200	aluminum bronze	87.8	...	...	...	...	9	3.2	...	...	...	...	...
C95300	aluminum bronze	88.8	...	...	...	...	10	1.2	...	...	...	...	...
C95400	aluminum bronze	85.2	...	...	...	...	10.8	4	...	...	...	...	...
C95410	aluminum bronze	83.2	...	...	...	2	10.8	4	...	...	...	...	...
C95500	nickel-aluminum bronze	81	...	...	...	4.2	10.8	4	...	...	...	...	...
C95520	nickel-aluminum bronze	79.1	...	...	...	5.1	11	4.8	...	...	...	...	...
C95700	manganese nickel aluminum bronze	74.8	...	...	...	2.2	7.5	3	12.5	...	...	...	...
C95800	nickel-aluminum bronze	81.3	...	...	...	4.5	9	4	1.2	...	...	...	...
C95900	aluminum bronze	83.2	...	...	...	...	12.8	4.0	...	...	...	...	...
C96400	copper-nickel	67	...	...	...	30	...	0.90	...	...	...	...	...
C96900	copper-nickel	76.8	8	...	...	15	...	...	0.20	...	...	...	...
C96970	copper-nickel-tin	85	6	...	...	9.0	...	...	...	...	...	...	...
C97300	leaded nickel bronze	55.5	2.2	9.5	21	12.5	...	...	...	...	...	...	...
C97600	leaded nickel bronze	65	4	4	6	20.2	...	...	...	...	...	...	...
C97800	leaded nickel bronze	65.5	4.8	1.8	2.5	25.5	...	...	...	...	...	...	...
C99500	special alloy	89.1	...	...	1.2	4.5	1.2	4.0	...	1.3	...	...	...

<sup>A</sup> Antimony 0.07, Boron 0.001.

- 4.1.13 Packaging and Package Marking (Section 20),
- 4.1.14 Keywords (Section 21), and
- 4.1.15 Supplementary Requirements.

**5. Ordering Information**

- 5.1 Include the following information in orders for product:
  - 5.1.1 ASTM designation and year of issue (for example, B505/B505M – 04),
  - 5.1.2 Copper Alloy UNS No. (for example, C93200), including HT if heat treatment is required.
  - 5.1.3 Condition (Table 9) and (as cast, heat treated, and so forth),
  - 5.1.4 Dimensions: inside diameter, outside diameter, thickness and width,
  - 5.1.5 Form: cross-section, such as tube, round, hexagon, octagon, square, or rectangle,
  - 5.1.6 Tolerances, if different from Section 10 and Tables 2-8.
  - 5.1.7 Length (including length tolerance if other than mill lengths),
  - 5.1.8 Number of castings or total weight, for each size and form,
  - 5.1.9 ASME Boiler and Pressure Vessel Code requirements (if required see Section 9),
  - 5.1.10 When castings are purchased for agencies of the U.S. Government, the Supplementary Requirements of Specification B824 may be specified.

5.2 The following requirements are optional and should be specified in the purchase order when required:

- 5.2.1 Chemical analysis of residual elements (Section 7 and Specification B824),
- 5.2.2 Mechanical requirements, (Section 8 Test Methods E8/E8M),
- 5.2.3 Witness inspection (Specification B824),
- 5.2.4 Certification (Specification B824),
- 5.2.5 Foundry test report (Specification B824),
- 5.2.6 Product marking (Specification B824),
- 5.2.7 Castings for seawater service (Section 6), and
- 5.2.8 Approval of weld repair and records of repair (Section 11).

**6. Materials and Manufacture**

6.1 For better corrosion resistance in seawater applications, castings in Copper Alloy UNS No. C95800 shall be given a

**TABLE 2 Suggested Heat Treatments**

Copper Alloy UNS No.	Solution Treatment (not less than 1 h followed by water quench), °F [°C]	Annealing Treatment (not less than 2 h followed by air cool), °F [°C]
C95300	1585–1635 [860–890]	1150–1225 [620–660]
C95400, C95410, C95500	1600–1675 [870–910]	1150–1225 [620–660]
C95520	(2 h followed by water quench) 1600–1700 [870–925]	925–1000 [495–540]

**TABLE 3 Finishing Allowances for Tube (Round Only)**

Finished Outside Diameter, in. [mm]	Finish Allowances Added to Finished or Print Dimensions of the Part, in. [mm]	
	Inside Diameter	Outside Diameter
All Alloys Except as Noted Below		
Up to 4 [102], excl	-0.031 [-0.79]	+ 0.031 [0.79]
4 [102] –5 [127], incl	-0.063 [-1.6]	+ 0.063 [1.6]
Over 5 [127]	-0.094 [-2.4]	+ 0.094 [2.4]
Copper Alloy UNS Nos. C85470, C86200, C86300, C86500, C87700, C87710, C87850, C89720, C89845, C95200, C95300, C95400, C95500, C95800, C95900, and C96400		
Up to 3 [76.2], incl	-0.125 [-3.2]	+ 0.063 [1.6]
Over 3 [76.2] –4 [102], incl	-0.125 [-3.2]	+ 0.094 [2.4]
Over 4 [102] –5½ [140], incl	-0.188 [-4.8]	+ 0.125 [3.2]
Over 5½ [140]	-0.250 [-6.4]	+ 0.188 [4.8]

**TABLE 4 Finishing Allowances for Rod and Bar**

Finished Outside Diameter or Distance Between Parallel Surfaces, in. [mm]	Rounds	Squares, Rectangles, Hexagons, Octagons
	All Alloys Except as Noted Below	
Up to 4 [102], excl	+ 0.031 [0.79]	+ 0.031 [0.79]
4 [102] –5 [127], incl	+ 0.063 [1.6]	+ 0.063 [1.6]
Over 5 [127]	+ 0.094 [2.4]	+ 0.094 [2.4]
Copper Alloy UNS Nos. C85470, C86200, C86300, C86500, C87700, C87710, C87850, C89720, C89845, C95200, C95300, C95400, C95500, C95800, C95900, and C96400		
Up to 3 [76.2], incl	+ 0.0625 [1.6]	+ 0.0625 [1.6]
Over 3 [76.2] –4 [102], incl	+ 0.093 [2.4]	+ 0.093 [2.4]
Over 4 [102] –5½ [140], incl	+ 0.125 [3.2]	+ 0.125 [3.2]
Over 5½ [140]	+ 0.188 [4.8]	+ 0.188 [4.8]

**TABLE 5 Diameter Tolerances for Rod and Bar**

Diameter or Distance Between Parallel Surfaces, in. [mm]	Tolerances, Plus <sup>A</sup> and Minus <sup>A</sup> in. [mm]	
	Rounds	Squares, Rectangles, Hexagons, Octagons
All Alloys Except as Noted Below		
Up to 4 [102], excl	0.005 [0.13]	0.016 [0.41]
4 [102] –5 [127], incl	0.008 [0.20]	0.016 [0.41]
Over 5 [127]	0.016 [0.41]	0.016 [0.41]
Copper Alloy UNS Nos. C85470, C86200, C86300, C86500, C87700, C87710, C87850, C89720, C89845, C95200, C95300, C95400, C95500, C95800, C95900, and C96400		
Up to 3 [76.2], incl	0.010 [0.25]	0.020 [0.51]
Over 3 [76.2] –4 [102], incl	0.015 [0.38]	0.020 [0.51]
Over 4 [102] –5½ [140], incl	0.020 [0.51]	0.020 [0.51]
Over 5½ [140]	0.025 [0.64]	0.025 [0.64]

<sup>A</sup> When tolerances are specified as all plus or all minus, double the values given.

temperature anneal heat treatment at 1250 °F ± 50 °F [675 °C ± 10 °C] for 6 h minimum. Cooling shall be by the fastest means possible that will not cause excessive distortion or cracking. Propeller castings shall be exempt from this requirement.

6.2 Copper Alloy UNS Nos. C95300, C95400, C95410, and C95500 may be supplied in the heat-treated condition to obtain the higher mechanical properties shown in Table 9. Suggested heat treatments for these alloys and Copper Alloy UNS No. C95520 are given in Table 2. Actual practice may vary by manufacturer.

6.3 Copper Alloy UNS No. C95520 is used only in the quench-hardened and tempered (TQ30) condition, see Table 2.

**TABLE 6 Diameter Tolerances for Tube (Round Only)**

Average Outside Diameter, in. [mm]	Tolerances, in. [mm]		
	Outside Diameter	Inside Diameter	
	Plus <sup>A</sup> or Minus <sup>A</sup>	Plus <sup>B</sup>	Minus <sup>B</sup>
All Alloys Except as Noted Below			
Up to 4 [102], excl	0.005 [0.13]	0.012 [0.30]	0.033 [0.84]
4 [102] –5 [127], incl	0.008 [0.20]	0.016 [0.41]	0.046 [1.2]
Over 5 [127]	0.016 [0.41]	0.032 [0.81]	0.064 [1.6]
Copper Alloy UNS Nos. C85470, C86200, C86300, C86500, C87700, C87710, C87850, C89720, C89845, C95200, C95300, C95400, C95500, C95800, C95900, and C96400			
Up to 3 [76], incl	0.010 [0.25]	0.012 [0.32]	0.033 [0.84]
Over 3 [76] –4 [102], incl	0.015 [0.38]	0.015 [0.38]	0.050 [1.3]
Over 4 [102] –5½ [140], incl	0.020 [0.51]	0.025 [0.64]	0.070 [1.8]
Over 5½ [140]	0.025 [0.64]	0.035 [0.86]	0.090 [2.3]

<sup>A</sup> When tolerances are specified as all plus or all minus double the values given.  
<sup>B</sup> When tolerances are specified as all plus or all minus, total the values given.

**TABLE 7 Roundness Tolerances**

Outside Diameter, in. [mm]	Maximum Out-of-Roundness, <sup>A</sup> in. [mm]
Up to 4 [102], excl	0.020 [0.51]
4 [102] –5 [127], incl	0.032 [0.81]
Over 5 [127]	0.064 [1.6]
Copper Alloy UNS Nos. C85470, C86200, C86300, C86500, C87700, C87710, C87850, C89720, C89845, C95200, C95300, C95400, C95500, C95800, C95900, and C96400	
Up to 3 [76.2], incl	0.025 [0.64]
Over 3 [76.2] –4 [102], incl	0.040 [1.0]
Over 4 [102] –5½ [140], incl	0.060 [1.5]
Over 5½ [140]	0.075 [1.9]

<sup>A</sup> The deviation from roundness is measured as the difference between major and minor diameters as determined at any one cross section of the tube.

**TABLE 8 Tolerances for Shapes**

Outside Dimension, <sup>A</sup> in. [mm]		Inside Dimension, <sup>B</sup> in. [mm]	
All Alloys Except as Noted Below			
Plus	Minus	Plus	Minus
0.016 [0.41]	0.016 [0.41]	0.032 [0.81]	0.064 [1.6]
Copper Alloy UNS Nos. C85470, C86200, C86300, C86500, C87700, C87710, C87850, C89720, C89845, C95200, C95300, C95400, C95500, C95800, C95900, and C96400			

Dimensional tolerances shall be subject to agreement between purchaser and manufacturer.

<sup>A</sup> When tolerances are specified as all plus or all minus, double the values given.  
<sup>B</sup> When tolerances are specified as all plus or all minus, total the values given.

6.4 Copper Alloy UNS No. C96900 is normally supplied heat treated at 1520 °F [825 °C] for 1 h followed by a water quench, then aged at 800 °F [425 °C] for 4 h followed by a water quench.

6.5 If test bar coupons representing castings made in Copper Alloy UNS Nos. C94700HT, C95300HT, C95400HT, C95410HT, C95500HT, C95520HT, C95800 temper annealed, C95900 annealed, and C96900 are removed from the continuous castings before heat treatment, the coupons shall be heat treated with the continuous castings.

**7. Chemical Composition**

7.1 The continuous castings shall conform to the requirements for elements shown in Table 10.

7.2 These composition limits do not preclude the presence of other elements. By agreement between the manufacturer and purchaser, limits may be established and analysis required for unnamed elements.

7.3 For alloys in which copper is listed as “remainder,” copper is the difference between the sum of results of all elements determined and 100 %.

7.4 For alloys in which zinc is listed as “remainder,” either copper or zinc may be taken as the difference between the sum of results of all other elements determined and 100 %.

7.5 When all named elements in Table 10 with values are analyzed, their sum shall be as specified in Table 11.

7.6 Analysis shall be made for Other Elements only when specified in the purchase order, and shall be considered outside the limits specified in Table 11.

**8. Mechanical Property Requirements**

8.1 Reference should be made to Table 9 for minimum mechanical requirements.

8.2 Mechanical tests are required only when specified by the purchaser in the purchase order.

8.3 Exceptions to mechanical property requirements may be taken in the case of small diameter solids or castings having section thicknesses less than the ½ in. [12.7 mm] diameter of the standard tension test specimen. In these cases, mechanical property requirements shall be subject to agreement between the purchaser and the manufacturer. For suggested dimensions of substandard test bars, see Test Methods E8/E8M.

**9. ASME Requirements**

9.1 When specified in the purchase order to meet *ASME Boiler and Pressure Vessel Code* requirements, continuous castings shall comply with the following:

9.1.1 Certification requirements of Specification B824.

9.1.2 Foundry test report requirements of Specification B824.

9.1.3 Continuous castings shall be marked with the manufacturer’s name, the Copper Alloy UNS No., and the casting quality factor. In addition, heat numbers, or serial numbers that are traceable to heat numbers, shall be marked on all pressure-containing castings individually weighing 50 lb [22.7 kg] or more. Pressure-containing castings weighing less than 50 lb [22.7 kg] shall be marked with either the heat number or a serial number that will identify the casting as to the month in which it was poured. Marking shall be in such a position as not to injure the usefulness of the casting.

9.1.4 When Copper Alloy UNS No. C95200 is specified to meet *ASME Boiler and Pressure Vessel Code* requirements, a sample from each 2000 lb interval or continuous casting shall be tested. Each continuous casting from which the test bar was taken shall be identified should retesting be required. If all of the test bars from the initial sampling meet the requirements, the lot shall be acceptable. The fractured bars shall be retained for chemical verification.

TABLE 9 Mechanical Requirements

Copper Alloy UNS No.	Tensile Strength, min <sup>A</sup>		Yield Strength, at 0.5 % Extension Under Load, min <sup>A</sup>		Elongation in 4D or 2 in. or 50 mm, min, %	Brinell Hardness, min	Remarks
	ksi <sup>B</sup>	MPa <sup>C</sup>	ksi <sup>B</sup>	MPa <sup>C</sup>			
C83470	36	248	15	103	15		
C83600	36	248	19	131	15		
C83800	30	207	15	97	16		
C84200	32	221	16	110	13		
C84400	30	207	15	103	16		
C84800	30	207	15	103	16		
C85470	50	345	21	150	15		
C85700	40	276	14	97	15		
C86200	90	621	45	310	18		
C86300	110	758	62	427	14		
C86500	70	483	25	172	25		
C87700	25	172	17	117	18		
C87710	64	441	22	152	20		
C87850	65	448	25	172	8	108 [500 kg]	
C89320	35	241	18	124	15		
C89545	36	248	15	103	20		
C89720	36	250	16	110	18	70 [1000 kg]	
C89838	36	248	15	103	20		
C89845	36	248	15	103	15		
C90300	44	303	22	152	18		
C90500	44	303	25	172	10		
C90700	40	276	25	172	10		
C91000	30	207	...	...	...		
C91300	...	...	...	...	...	160 [3000 kg]	
C92200	38	262	19	131	18		
C92300	40	276	19	131	16		
C92500	40	276	24	165	10		
C92700	38	252	20	138	8	...	Rockwell B72-82
C92800	...	...	...	...	...		
C92900	45	310	25	172	8		
C93200	35	241	20	138	10		
C93400	34	234	20	138	8		
C93500	30	207	16	110	12		
C93600	33	227	20	138	10		
C93700	35	241	20	138	6		
C93800	25	172	16	110	5		
C93900	25	172	16	110	5		
C94000	...	...	...	...	...	80 [500 kg]	
C94100	25	172	17	117	7		
C94300	21	145	15	103	7		
C94700	45	310	20	138	25		
C94700HT	75	517	50	345	5		heat treated
C94800	40	276	20	138	20		
C95200	68	469	26	179	20		
C95300	70	483	26	179	25		
C95300HT	80	552	40	276	12		heat treated
C95400	85	586	32	221	12		
C95400HT	95	655	45	310	10		heat treated
C95410	85	586	32	221	12		
C95410HT	95	655	45	310	10		heat treated
C95500	95	655	42	290	10		
C95500HT	110	758	62	427	8		heat treated
C95520HT	125	862	95 <sup>D</sup>	655 <sup>D</sup>	2	262 [3000 kg]	heat treated <sup>E</sup>
C95700	90	620	40	275	15		
C95800 <sup>F</sup>	85	586	35	241	18		
C95900	...	...	...	...	...	241 [3000 kg]	
C96400	65	448	35	241	25		
C96900HT	110	758	105 <sup>D</sup>	724 <sup>D</sup>	4		Rockwell C32
C96970	105	723	90 <sup>D</sup>	620 <sup>D</sup>	3		Rockwell C27
C97300	30	207	15	103	8		
C97600	40	276	20	138	10		
C97800	45	310	22	152	8		
C99500	70	483	40	276	12		

<sup>A</sup> Minimum tensile strength and yield strength shall be reduced 10 % for cast bars having a cross section, thickness, diameter, or wall of 4 in. [102 mm] or more. The cross sections are the diameter of a round solid, the distance across the flats of a solid hexagon, the thickness of a rectangle, and the wall thickness of a tube.

<sup>B</sup> ksi = 1000 psi.

<sup>C</sup> See Appendix.

<sup>D</sup> Yield strength at 0.2 % offset, min<sup>A</sup>, ksi<sup>B</sup>, MPa<sup>C</sup>.

<sup>E</sup> Copper Alloy UNS No. C95520 used only in the quench-hardened and tempered (TQ30) condition.

<sup>F</sup> As cast or temper annealed.

TABLE 10 Chemical Requirements

Copper Alloy UNS. No.	Composition, % max, except as indicated												
	Copper	Tin	Lead	Zinc	Iron	Nickel Including Cobalt	Aluminum	Manganese	Bismuth	Antimony	Sulfur	Phosphorus	Silicon
C83470	90.0–96.0 <sup>A</sup>	3.0–5.0	0.09	1.0–3.0	0.50	1.0	0.01	...	...	0.20	0.20–0.6	1.0	0.01
C83600	84.0–86.0 <sup>A</sup>	4.0–6.0	4.0–6.0	4.0–6.0	0.30	1.0 <sup>A</sup>	0.005	...	...	0.25	0.08	1.5	0.005
C83800	82.0–83.8 <sup>A</sup>	3.3–4.2	5.0–7.0	5.0–8.0	0.30	1.0 <sup>A</sup>	0.005	...	...	0.25	0.08	1.5	0.005
C84200	78.0–82.0 <sup>A</sup>	4.0–6.0	2.0–3.0	10.0–16.0	0.40	0.8 <sup>A</sup>	0.005	...	...	0.25	0.08	1.5	0.005
C84400	78.0–82.0 <sup>A</sup>	2.3–3.5	6.0–8.0	7.0–10.0	0.40	1.0 <sup>A</sup>	0.005	...	...	0.25	0.08	1.5	0.005
C84800	75.0–77.0 <sup>A</sup>	2.0–3.0	5.5–7.0	13.0–17.0	0.40	1.0 <sup>A</sup>	0.005	...	...	0.25	0.08	1.5	0.005
C85470	60.0–65.0	1.0–4.0	0.09	Rem	0.20	...	0.10–1.0	...	...	...	...	0.02–0.25	...
C85700	58.0–64.0 <sup>A</sup>	0.50–1.5	0.8–1.5	32.0–40.0	0.7	1.0 <sup>A</sup>	0.8	...	...	...	...	...	0.05
C86200	60.0–66.0 <sup>A</sup>	0.20	0.20	22.0–28.0	2.0–4.0	1.0 <sup>A</sup>	3.0–4.9	2.5–5.0	...	...	...	...	...
C86300	60.0–66.0 <sup>A</sup>	0.20	0.20	22.0–28.0	2.0–4.0	1.0 <sup>A</sup>	5.0–7.5	2.5–5.0	...	...	...	...	...
C86500	55.0–60.0 <sup>A</sup>	1.0	0.40	36.0–42.0	0.40–2.0	1.0 <sup>A</sup>	0.50–1.5	0.10–1.5	...	...	...	...	...
C87700	87.5 min	2.0	0.09	7.0–9.0	0.50	0.25 <sup>B</sup>	...	0.8	...	0.10	...	0.15	2.5–3.5
C87710	84 min	2.0	0.09	9.0–11.0	0.50	0.25 <sup>B</sup>	...	0.8	...	0.10	...	0.15	3.0–5.0
C87850	75.0–78.0	0.30	0.09	Rem	0.10	0.20	...	0.10	...	0.10	...	0.05–0.20	2.7–3.4
C89320	87.0–91.0	5.0–7.0	0.09	1.0	0.20	1.0	0.005	...	4.0–6.0	0.35	0.08	0.30	0.005
C89545 <sup>C</sup>	66.0–72.0	0.50	0.09	27.0–31.0	0.30	1.0	0.6–1.5	0.30	0.20–0.9	...	...	0.01–0.15	0.30
C89720 <sup>D</sup>	63.0 min	0.60–1.5	0.09	26.0–32.0	0.10	0.10	0.35–1.5	0.10	0.50–2.0	0.02–0.20	...	0.02	0.40–1.0
C89838	78.0–85.0	1.5–4.0	0.09	12.0–18.0	0.30	0.50	0.01	...	0.20–0.09	0.05	...	0.05	0.01
C89845	82.5–87.5	3.0–5.0	0.09	6.0–9.0	0.30	1.5–2.5	0.01	...	1.0–2.0	0.25	...	0.05	0.01
C90300	86.0–89.0 <sup>A</sup>	7.5–9.0	0.30	3.0–5.0	0.20	1.0 <sup>A</sup>	0.005	...	...	0.20	0.05	1.5	0.005
C90500	86.0–89.0 <sup>A</sup>	9.0–11.0	0.30	1.0–3.0	0.20	1.0 <sup>A</sup>	0.005	...	...	0.20	0.05	1.5	0.005
C90700	88.0–90.0 <sup>A</sup>	10.0–12.0	0.50	0.50	0.15	0.50 <sup>A</sup>	0.005	...	...	0.20	0.05	1.5	0.005
C91000	84.0–86.0 <sup>A</sup>	14.0–16.0	0.20	1.5	0.10	0.8 <sup>A</sup>	0.005	...	...	0.20	0.05	1.5	0.005
C91300	79.0–82.0 <sup>A</sup>	18.0–20.0	0.25	0.25	0.25	0.50 <sup>A</sup>	0.005	...	...	0.20	0.05	1.5	0.005
C92200	86.0–90.0 <sup>A</sup>	5.5–6.5	1.0–2.0	3.0–5.0	0.25	1.0 <sup>A</sup>	0.005	...	...	0.25	0.05	1.5	0.005
C92300	85.0–89.0 <sup>A</sup>	7.5–9.0	0.3–1.0	2.5–5.0	0.25	1.0 <sup>A</sup>	0.005	...	...	0.25	0.05	1.5	0.005
C92500	85.0–88.0 <sup>A</sup>	10.0–12.0	1.0–1.5	0.50	0.30	0.8–1.5 <sup>A</sup>	0.005	...	...	0.25	0.05	1.5	0.005
C92700	86.0–89.0 <sup>A</sup>	9.0–11.0	1.0–2.5	0.7	0.20	1.0 <sup>A</sup>	0.005	...	...	0.25	0.05	1.5	0.005
C92800	78.0–82.0 <sup>A</sup>	15.0–17.0	4.0–6.0	0.8	0.20	0.8 <sup>A</sup>	0.005	...	...	0.25	0.05	1.5	0.005
C92900	82.0–86.0 <sup>A</sup>	9.0–11.0	2.0–3.2	0.25	0.20	2.8–4.0 <sup>A</sup>	0.005	...	...	0.25	0.05	1.5	0.005
C93200	81.0–85.0 <sup>A</sup>	6.3–7.5	6.0–8.0	2.0–4.0	0.20	1.0 <sup>A</sup>	0.005	...	...	0.35	0.08	1.5	0.005
C93400	82.0–85.0 <sup>A</sup>	7.0–9.0	7.0–9.0	0.8	0.20	1.0 <sup>A</sup>	0.005	...	...	0.50	0.08	1.5	0.005
C93500	83.0–86.0 <sup>A</sup>	4.3–6.0	8.0–10.0	2.0	0.20	1.0 <sup>A</sup>	0.005	...	...	0.30	0.08	1.5	0.005
C93600	79.0–83.0	6.0–8.0	11.0–13.0	1.0	0.20	1.0	0.005	...	...	0.55	0.08	1.5	0.005
C93700	78.0–82.0	9.0–11.0	8.0–11.0	0.8	0.7 <sup>E</sup>	0.50	0.005	...	...	0.50	0.08	1.5	0.005
C93800	75.0–79.0	6.3–7.5	13.0–16.0	0.8	0.15	1.0	0.005	...	...	0.8	0.08	1.5	0.005
C93900	76.5–79.5	5.0–7.0	14.0–18.0	1.5	0.40	0.8	0.005	...	...	0.50	0.08	1.5	0.005
C94000 <sup>F</sup>	69.0–72.0	12.0–14.0	14.0–16.0	0.50	0.25	0.50–1.0	0.005	...	...	0.50	0.25 <sup>F</sup>	1.5	0.005
C94100 <sup>F</sup>	72.0–79.0	4.5–6.5	18.0–22.0	1.0	0.25	1.0	0.005	...	...	0.8	0.25 <sup>F</sup>	1.5	0.005
C94300 <sup>F</sup>	67.0–72.0	4.5–6.0	23.0–27.0	0.8	0.15	1.0	0.005	...	...	0.8	0.25 <sup>F</sup>	1.5	0.005
C94700 <sup>G</sup>	85.0–90.0	4.5–6.0	0.09 <sup>G</sup>	1.0–2.5	0.25	4.5–6.0	0.005	0.20	...	0.15	0.05	0.05	0.005
C94800	84.0–89.0	4.5–6.0	0.3–1.0	1.0–2.5	0.25	4.5–6.0	0.005	0.20	...	0.15	0.05	0.05	0.005
C95200	86.0 min	...	...	...	2.5–4.0	...	8.5–9.5	...	...	...	...	...	...
C95300	86.0 min	...	...	...	0.8–1.5	...	9.0–11.0	...	...	...	...	...	...
C95400	83.0 min	...	...	...	3.0–5.0	1.5	10.0–11.5	0.50	...	...	...	...	...
C95410	83.0 min	...	...	...	3.0–5.0	1.5–2.5	10.0–11.5	0.50	...	...	...	...	...
C95500	78.0 min	...	...	...	3.0–5.0	3.0–5.5	10.0–11.5	3.5	...	...	...	...	...
C95520 <sup>H</sup>	74.5 min	0.25	0.03	0.30	4.0–5.5	4.2–6.0	10.5–11.5	1.5	...	...	...	...	0.15
C95700	71.0 min	...	...	...	2.0–4.0	1.5–3.0	7.0–8.0	11.0–14.0	...	...	...	...	0.10
C95800	79.0 min	...	0.03	...	3.5–4.5 <sup>I</sup>	4.0–5.0 <sup>I</sup>	8.5–9.5	0.8–1.5	...	...	...	...	0.10
C95900	remainder	...	...	...	3.0–5.0	0.50	12.0–13.5	...	...	...	...	...	...
C96400 <sup>J</sup>	remainder	...	0.01	...	0.25–1.50	28.0–32.0	...	1.5	...	...	0.02	0.02	0.50
C96900 <sup>K</sup>	remainder	7.5–8.5	0.02	0.50	...	14.5–15.5	...	0.05–0.30	...	...	...	...	0.30
C96970 <sup>L</sup>	remainder	5.5–6.5	0.02	0.50	0.50	8.5–9.5	...	0.30	...	...	...	...	...

ASME NIPDF.COM : Click to view the full PDF of ASME BPVC.II.B (ASME BPVC Section II part B) 2025

TABLE 10 Continued

Copper Alloy UNS. No.	Composition, % max, except as indicated													
	Copper	Tin	Lead	Zinc	Iron	Nickel Including Cobalt	Aluminum	Manganese	Bismuth	Antimony	Sulfur	Phosphorus	Silicon	
C97300	53.0–58.0	1.5–3.0	8.0–11.0	17.0–25.0	1.5	11.0–14.0	0.005	0.50	...	0.35	0.08	0.05	0.15	
C97600	63.0–67.0	3.5–4.5	3.0–5.0	3.0–9.0	1.5	19.0–21.5	0.005	1.0	...	0.25	0.08	0.05	0.15	
C97800	64.0–67.0	4.0–5.5	1.0–2.5	1.0–4.0	1.5	24.0–27.0	0.005	1.0	...	0.20	0.08	0.05	0.15	
C99500	remainder	...	0.09	0.50–2.0	3.0–5.0	3.5–5.50 <sup>B</sup>	0.5–2.0	0.5	...	...	...	...	0.50–2.0	

<sup>A</sup> In determining copper minimum, copper may be calculated as copper plus nickel.

<sup>B</sup> Not including Co.

<sup>C</sup> Boron 0.02.

<sup>D</sup> Boron 0.0005-0.01.

<sup>E</sup> Iron shall be 0.35 % max, when used for steel-backed bearings.

<sup>F</sup> For Continuous Castings S shall be 0.25% max.

<sup>G</sup> It is possible that the mechanical requirements of Copper Alloy UNS No. C94700 in the heat-treated condition will not be attained if the lead content exceeds 0.01 %.

<sup>H</sup> Chromium content shall be 0.05 max, cobalt 0.20 max.

<sup>I</sup> Iron content shall not exceed nickel content.

<sup>J</sup> Chemical requirements for other elements: carbon 0.15 % max and niobium 0.50 % to 1.5 %.

<sup>K</sup> Magnesium 0.15 max, niobium 0.10 max.

<sup>L</sup> Chemical requirements for other elements: magnesium 0.15 % max, niobium 0.10 % max.

TABLE 11 Sum of All Named Elements Analyzed

Copper Alloy UNS No.	Copper Plus Named Elements, % min	Copper Alloy UNS No.	Copper Plus Named Elements, % min
C83470	99.5	C92900	99.3
C83600	99.3	C93200	99.0
C83800	99.3	C93400	99.0
C84200	99.3	C93500	99.0
C84400	99.3	C93600	99.3
C84800	99.3	C93700	99.0
C85470	99.5	C93800	99.0
C85700	98.7	C93900	98.9
C86200	99.0	C94000	98.7
C86300	99.0	C94100	98.7
C86500	99.0	C94300	99.0
C87700	99.2	C94700	98.7
C87710	99.2	C94800	98.7
C87850	99.5	C95200	99.0
C89320	99.5	C95300	99.0
C89545	99.5	C95400	99.5
C89720	99.5	C95410	99.5
C89838	99.5	C95500	99.5
C89845	99.5	C95520	99.5
C90300	99.4	C95700	99.5
C90500	99.7	C95800	99.5
C90700	99.4	C95900	99.5
C91000	99.4	C96400	99.5
C91300	99.4	C96900	99.5
C92200	99.3	C96970	99.5
C92300	99.3	C97300	99.0
C92500	99.3	C97600	99.7
C92700	99.3	C97800	99.6
C92800	99.3	C99500	99.7

TABLE 12 Straightness Tolerances

Product	Length, <sup>A</sup> ft [m]	Maximum Curvature <sup>B</sup> (Depth of Arc), in. [mm]
Round rod or tube	up to 10 [3.05] 10 [3.05] and over	¼ [6.4] in any 5 ft [1.52 m] portion ½ [13] in any 10 ft [3.05 m] portion <sup>A</sup>
Bar and shape	any length	½ [13] in any 6 ft [1.83 m] portion <sup>A,B</sup>

<sup>A</sup> Of total length.

<sup>B</sup> Applicable to any longitudinal surface or edge.

10. Dimensions and Permissible Variations

10.1 Allowance for finishing over maximum outside dimension and under inside dimension of round tubes to be machined shall be as shown in Table 3. Allowances for finishing the outside diameter of rounds and distance between parallel surfaces of bars to be machined shall be as shown in Table 4. Table 3 and Table 4 are to be used in conjunction with Tolerance Table 6 and Table 5, respectively.

10.2 Concentricity:

10.2.1 All Alloys Except as Noted in 10.2.2—The outside periphery of continuously cast tubing shall be concentric with the bore within a permissible variation of 2 % of the nominal wall thickness over ¼ in. [6.35 mm]. If the wall thickness is ¼ in. or less, permissible variations in concentricity shall be subject to agreement between the purchaser and the manufacturer.

10.2.2 Copper Alloy UNS Nos. C86200, C86300, C86400, C95200, C95300, C95400, C95410, C95500, C95520, C95800, C95900, and C96400—The outside periphery of

continuously cast tubing shall be concentric with the bore within a permissible variation of 4 % of the nominal wall thickness.

10.3 Diameter Tolerances for Continuously Cast Rod and Bar—See Table 5.

10.4 Diameter Tolerances for Continuously Cast Tube (Round only)—See Table 6.

10.5 Roundness—For continuously cast tubing in straight lengths, the roundness tolerances shall be as shown in Table 7.

10.6 Dimensional Tolerances for All Other Shapes (not Covered by 10.1 or 10.2)—See Table 8.

11. Casting Repair

11.1 Continuous castings shall not be mechanically repaired, plugged, or burned in.

11.2 Weld repair is permitted for Copper Alloy UNS Nos. C95200, C95300, C95400, C95410, C95500, C95800, and C95900.

11.3 Weld repairs may be made at the manufacturer’s discretion, provided each excavation does not exceed 20 % of the casting section or wall thickness or 4 % of the casting surface area.

11.4 Excavations that exceed those described in 11.3 may be made at the manufacturer’s discretion, except that when specified in the purchase order (5.2), the weld procedure shall be approved by the purchaser and the following records shall be maintained:

- 11.4.1 A sketch or drawing showing the dimensions, depth, and location of excavations,
- 11.4.2 Post-weld heat treatment, when applicable,
- 11.4.3 Weld repair inspection results,
- 11.4.4 Casting identification number,
- 11.4.5 Weld procedure identification number,
- 11.4.6 Welder identification, and
- 11.4.7 Name of inspector.

11.5 The castings shall not be impregnated without approval of the purchaser.

11.6 Weld repair of other alloys in this specification is not permitted without approval by the purchaser.

12. Sampling

12.1 Sampling shall be accordance with the requirements of Practice E255.

12.2 Unless otherwise specified, a lot shall consist of castings of the same composition and same cross-sectional dimensions, produced during the continuous operation of one casting machine, and submitted for inspection at one time.

12.3 A sample for chemical analysis shall be taken from each lot at each interval of 2000 lb [910 kg] of continuous production of the lot. When castings are produced from alloy ingots of known composition, the sampling interval may be raised to one sample for each 4000 lb [1810 kg] of continuous production of the lot.

12.4 When mechanical testing is specified by the purchaser in the purchase order one sample for tension testing shall be taken from each lot. This sample may be taken before mechanical straightening. Test bar specimens shall be positively identified with the castings they represent. Where castings are heat treated, test bar specimens shall be heat treated with the castings they represent.

12.5 When Copper Alloy UNS No. C95200 is specified for ASME Boiler and Pressure Vessel Application, a sample from each 2000 lb interval or continuous casting shall be tested. Each continuous cast bar from which the test bar was taken shall be identified should retesting be required. If all of the test bars from the initial sampling meet the requirements, the lot shall be acceptable.

12.5.1 The fractured bars shall be retained for chemical verification.

12.6 Tension test bar specimens shall be taken from continuous castings in accordance with Fig. 6 of Practice B208.

### 13. Test Methods

13.1 Analytical chemical methods are given in Specification B824 (Section 13).

13.2 Brinell Hardness Reading shall be taken on the grip end of the tension test bar and shall be made in accordance with Test Method E10. If a Brinell hardness is required and a tension test is not required, testing shall be in accordance with Test Method E10.

13.3 Rockwell Hardness Reading shall be taken on the grip end of the tension test bar and shall be made in accordance with Test Methods E18. If a Rockwell hardness is required and a tension test is not required, testing shall be in accordance with Test Methods E18.

### 14. Product Marking

14.1 At the request of the purchaser castings shall be marked with the alloy number.

### 15. Keywords

15.1 continuous castings; copper alloy castings

## APPENDIX

### (Nonmandatory Information)

#### X1. METRIC EQUIVALENTS

X1.1 The SI unit for strength properties now shown is in accordance with the International System of Units (SI). The derived SI unit for force is the newton (N), which is defined as that force which when applied to a body having a mass of one kilogram gives it an acceleration of one metre per second squared ( $N = \text{kg} \cdot \text{m}/\text{s}^2$ ). The derived SI unit for pressure or

stress is the newton per square metre ( $\text{N}/\text{m}^2$ ), which has been named the pascal (Pa) by the General Conference on Weights and Measures. Since  $1 \text{ ksi} = 6\,894\,757 \text{ Pa}$  the metric equivalents are expressed as megapascal (MPa), which is the same as  $\text{MN}/\text{m}^2$  and  $\text{N}/\text{mm}^2$ .

#### SUMMARY OF CHANGES

Committee B05 has identified the location of selected changes to this standard since the last issue (B505/B505M – 18) that may impact the use of this standard. (Approved Oct. 1, 2022.)

(1) Added UNS Alloy Nos. C89545, C89838, and C89845 to Table 1, Table 3, Table 4, Table 5, Table 6, Table 7, Table 8, Table 9, Table 10, and Table 11.

*ASTM International takes no position respecting the validity of any patent rights asserted in connection with any item mentioned in this standard. Users of this standard are expressly advised that determination of the validity of any such patent rights, and the risk of infringement of such rights, are entirely their own responsibility.*

*This standard is subject to revision at any time by the responsible technical committee and must be reviewed every five years and if not revised, either reapproved or withdrawn. Your comments are invited either for revision of this standard or for additional standards and should be addressed to ASTM International Headquarters. Your comments will receive careful consideration at a meeting of the responsible technical committee, which you may attend. If you feel that your comments have not received a fair hearing you should make your views known to the ASTM Committee on Standards, at the address shown below.*

*This standard is copyrighted by ASTM International, 100 Barr Harbor Drive, PO Box C700, West Conshohocken, PA 19428-2959, United States. Individual reprints (single or multiple copies) of this standard may be obtained by contacting ASTM at the above address or at 610-832-9585 (phone), 610-832-9555 (fax), or [service@astm.org](mailto:service@astm.org) (e-mail); or through the ASTM website ([www.astm.org](http://www.astm.org)). Permission rights to photocopy the standard may also be secured from the Copyright Clearance Center, 222 Rosewood Drive, Danvers, MA 01923, Tel: (978) 646-2600; <http://www.copyright.com/>*

ASMENORMDOC.COM : Click to view the full PDF of ASME BPVC.II.B (ASME BPVC Section II part B) 2025

# SPECIFICATION FOR NICKEL-IRON- CHROMIUM-SILICON ALLOY BARS AND SHAPES



**SB-511**

(Identical with ASTM Specification B511-01 (2009) except that certification has been made mandatory.)

ASMENORMDOC.COM : Click to view the full PDF of ASME BPVC.II.B (ASME BPVC Section II part B) 2025

# SPECIFICATION FOR NICKEL-IRON-CHROMIUM-SILICON ALLOY BARS AND SHAPES



SB-511

[Identical with ASTM Specification B 511-01(2009) except that certification has been made mandatory.]

## 1. Scope

**1.1** This specification covers wrought alloys UNS N08330 and UNS N08332 in the form of hot-finished and cold-finished bar and shapes intended for heat-resisting applications and general corrosive service.

**1.2** The values stated in inch-pound units are to be regarded as the standard. The values given in parentheses are for information only.

**1.3** *This standard does not purport to address all of the safety concerns, if any, associated with its use. It is the responsibility of the user of this standard to become familiar with all hazards including those identified in the appropriate Material Safety Data Sheet (MSDS) for this product/material as provided by the manufacturer, to establish appropriate safety and health practices, and determine the applicability of regulatory limitations prior to use.*

## 2. Referenced Documents

### 2.1 ASTM Standards:

- B 536 Specification for Nickel-Iron-Chromium-Silicon Alloys (UNS N08330 and N08332) Plate, Sheet, and Strip
- B 880 Specification for General Requirements for Chemical Check Analysis Limits for Nickel, Nickel Alloys and Cobalt Alloys
- E 8 Test Methods for Tension Testing of Metallic Materials
- E 29 Practice for Using Significant Digits in Test Data to Determine Conformance with Specifications
- E 112 Test Methods for Determining Average Grain Size
- E 1473 Test Methods for Chemical Analysis of Nickel, Cobalt, and High-Temperature Alloys

## 3. Terminology

### 3.1 Definitions of Terms Specific to This Standard:

**3.1.1** *bar, n* — material round, rectangular, hexagonal, octagonal, or square solid section, furnished in straight lengths.

**3.1.2** *shapes, n* — material of solid section in such forms as angles, channels, tees, I-beams, and four-fluted bars.

## 4. Ordering Information

**4.1** It is the responsibility of the purchaser to specify all requirements that are necessary for the safe and satisfactory performance of material ordered under this specification. Examples of such requirements include, but are not limited to the following:

- 4.1.1** Alloy (Table 1),
- 4.1.2** Quantity (weight or number of pieces),
- 4.1.3** ASTM designation and year of issue,
- 4.1.4** Section (round, square, I-beam, etc.),
- 4.1.5** Dimension, including length,

TABLE 1  
MECHANICAL PROPERTIES

Alloy	Condition	Tensile Strength, min, psi (MPa)	Yield	Elongation
			Strength, 0.2% Offset, min, psi (MPa)	in 2 in. or 50 mm, or 4D, min, %
UNS N08330	Annealed	70,000 (483)	30,000 (207)	30 <sup>4</sup>
UNS N08332	Annealed	67,000 (462)	27,000 (186)	30

<sup>4</sup> Applies to round bar only. For other cross-sections and shapes the minimum elongation shall be 25%.

TABLE 2  
CHEMICAL REQUIREMENTS

Element	Composition Limits, %
C	... <sup>A</sup>
Mn	2.00 max
P	0.03 max
S	0.03 max
Si	0.75–1.50
Cr	17.0–20.0
Ni	34.0–37.0
Cu	1.00 max
Pb	0.005 max
Sn	0.025 max
Fe	Remainder <sup>B</sup>

<sup>A</sup> Alloy UNS N08330: 0.08 max.

Alloy UNS N08332: 0.05–0.10.

<sup>B</sup> Element shall be determined arithmetically by difference.

**4.1.6 Certification** — Certification is required.

**4.1.7 Samples for Product (Check) Analysis** — State whether samples for product (check) analysis shall be furnished.

**4.1.8 Purchaser Inspection** — If a purchaser wishes to witness tests or inspections of material at the place of manufacture, the purchase order must so state indicating which tests or inspections are to be witnessed.

## 5. Materials and Manufacture

**5.1** All material shall be furnished in the heat-treated condition, except that cold-drawn hexagons may be given a cold-draw sizing pass subsequent to the final heat treatment.

NOTE 1 — Hot-finished rectangular bar in widths 10 in. (254 mm) and under may be furnished as hot-finished plate with sheared or cut edges in accordance with Specification B 536.

## 6. Chemical Composition

**6.1** The material shall conform to the requirements as to chemical composition specified in Table 2.

**6.2** If a product (check) analysis is performed by the purchaser, the material shall conform to the product (check) analysis variations in accordance with Specification B 880.

## 7. Mechanical and Other Properties

**7.1** The mechanical properties of the material at room temperature shall conform to those shown in Table 1.

**7.2 Grain Size** — Annealed alloy UNS N08332 shall conform to an average grain size of ASTM No. 5 or coarser.

**7.3 Annealing Temperature** — Alloy UNS N08330 shall be annealed at 1900°F (1040°C) minimum. Alloy UNS N08332 shall be annealed at 2100°F (1150°C) minimum.

## 8. Dimensions and Permissible Variations

**8.1** All bars and shapes shall conform to the permissible variations in dimensions specified in Tables 3–14, inclusive.

## 9. Workmanship, Finish, and Appearance

**9.1** The material shall be uniform in quality and temper, smooth, commercially straight, and free of injurious imperfections.

## 10. Sampling

### 10.1 Lot Definition:

**10.1.1** A lot for chemical analysis shall consist of one heat.

**10.1.2** A lot for mechanical properties and grain size testing shall consist of material from one heat of the same condition and cross section, and in no case more than 30 000 lb (13 600 kg) in weight.

### 10.2 Test Material Selection:

**10.2.1 Chemical Analysis** — Representative samples from each lot shall be taken during pouring or subsequent processing.

**10.2.1.1** Product (check) analysis shall be wholly the responsibility of the purchaser.

**10.2.2 Mechanical Properties and Grain Size** — Samples of the material to provide test specimens for mechanical properties and grain size shall be taken from such locations in each lot as to be representative of that lot.

## 11. Number of Tests

**11.1 Chemical Analysis** — One test per lot.

**11.2 Grain Size** — One test per lot.

**11.3 Mechanical Properties** — One test per lot.

## 12. Specimen Preparation

**12.1** Tension test specimens shall be taken from material in the final condition and tested in the direction of fabrication.

**12.1.1** All material shall be tested in full cross-section size when possible. When a full cross-section size test cannot be performed, the largest possible round specimen

TABLE 3  
PERMISSIBLE VARIATIONS IN SIZE OF HOT-ROLLED ROUND AND SQUARE BARS

Specified Size		Size Tolerance				Out-of-Round (Note 1) or Out-of-Square Section (Note 2)	
		Over		Under		in.	mm
in.	mm	in.	mm	in.	mm	in.	mm
$\frac{1}{4}$ to $\frac{5}{16}$	6.4 to 7.9	0.005	0.13	0.005	0.13	0.008	0.20
Over $\frac{5}{16}$ to $\frac{7}{16}$	7.9 to 11.1	0.006	0.15	0.006	0.15	0.009	0.23
Over $\frac{7}{16}$ to $\frac{5}{8}$	11.1 to 15.9	0.007	0.18	0.007	0.18	0.010	0.25
Over $\frac{5}{8}$ to $\frac{7}{8}$	15.9 to 22.2	0.008	0.20	0.008	0.20	0.012	0.30
Over $\frac{7}{8}$ to 1	22.2 to 25.4	0.009	0.23	0.009	0.23	0.013	0.33
Over 1 to $1\frac{1}{8}$	25.4 to 28.6	0.010	0.25	0.010	0.25	0.015	0.38
Over $1\frac{1}{8}$ to $1\frac{1}{4}$	28.6 to 31.8	0.011	0.28	0.011	0.28	0.016	0.41
Over $1\frac{1}{4}$ to $1\frac{3}{8}$	31.8 to 34.9	0.012	0.30	0.012	0.30	0.018	0.46
Over $1\frac{3}{8}$ to $1\frac{1}{2}$	34.9 to 38.1	0.014	0.36	0.014	0.36	0.021	0.53
Over $1\frac{1}{2}$ to 2	38.1 to 50.8	$\frac{1}{64}$	0.4	$\frac{1}{64}$	0.4	0.023	0.58
Over 2 to $2\frac{1}{2}$	50.8 to 63.5	$\frac{1}{32}$	0.8	0	...	0.023	0.58
Over $2\frac{1}{2}$ to $3\frac{1}{2}$	63.5 to 88.9	$\frac{3}{64}$	1.2	0	...	0.035	0.89
Over $3\frac{1}{2}$ to $4\frac{1}{2}$	88.9 to 114.3	$\frac{1}{16}$	1.6	0	...	0.046	1.17
Over $4\frac{1}{2}$ to $5\frac{1}{2}$	114.3 to 139.7	$\frac{5}{64}$	2.0	0	...	0.058	1.47
Over $5\frac{1}{2}$ to $6\frac{1}{2}$	139.7 to 165.1	$\frac{1}{8}$	3.2	0	...	0.070	1.78
Over $6\frac{1}{2}$ to 8	165.1 to 203.2	$\frac{5}{32}$	4.0	0	...	0.085	2.16

NOTE 1 — Out-of-round is the difference between the maximum and minimum diameters of the bar, measured at the same cross section.

NOTE 2 — Out-of-square section is the difference in the two dimensions at the same cross section of a square bar, each dimension being the distance between opposite faces.

NOTE 3 — Size tolerances for rounds in the size range from  $\frac{1}{4}$  to  $\frac{5}{16}$  in. (6.4 to 7.9 mm), incl, and for rounds in the size range from  $\frac{1}{4}$  in. (6.4 mm) to approximate  $\frac{5}{8}$  in. (15.9 mm), which are produced on rod mills in coils, are not shown herein.

NOTE 4 — Variations in size of coiled product made on rod mills are greater than size tolerances for product made on bar mills.

TABLE 4  
PERMISSIBLE VARIATIONS IN SIZE OF HOT-ROLLED HEXAGONAL AND OCTAGONAL BARS

Specified Sizes Measured Between Opposite Sides		Size Tolerance				Maximum Difference Measurements for Hexagons Only	
		Over		Under		in.	mm
in.	mm	in.	mm	in.	mm	in.	mm
$\frac{1}{2}$ to 1, incl	12.7 to 25.4	0.010	0.25	0.010	0.25	0.015	0.38
Over 1 to $1\frac{1}{2}$ , incl	25.4 to 38.1	0.021	0.53	0.021	0.53	0.025	0.64
Over $1\frac{1}{2}$ to 2, incl	38.1 to 50.8	$\frac{1}{32}$	0.8	$\frac{1}{32}$	0.8	$\frac{1}{32}$	0.8
Over 2 to $2\frac{1}{2}$ , incl	50.8 to 63.5	$\frac{3}{64}$	1.2	$\frac{3}{64}$	1.2	$\frac{3}{64}$	1.2
Over $2\frac{1}{2}$ to $3\frac{1}{2}$ , incl	63.5 to 88.9	$\frac{1}{16}$	1.6	$\frac{1}{16}$	1.6	$\frac{1}{16}$	1.6

TABLE 5  
PERMISSIBLE VARIATIONS IN THICKNESS AND WIDTH FOR HOT-ROLLED FLAT BARS

Specified Widths, in.	Thickness Tolerances, in., for Given Thickness										
	$\frac{1}{8}$ to $\frac{1}{2}$ , incl	Over $\frac{1}{2}$ to 1, incl	Over 1 to 2, incl	Over 2 to 4, incl		Over 4 to 6, incl		Over 6 to 8, incl		Width Tolerance	
				Over	Under	Over	Under	Over	Under	Over	Under
To 1, incl	0.008	0.010	...	...	...	...	...	...	...	0.015	0.015
Over 1 to 2, incl	0.012	0.015	0.031	...	...	...	...	...	...	0.031	0.031
Over 2 to 4, incl	0.015	0.020	0.031	0.062	0.031	...	...	...	...	0.062	0.031
Over 4 to 6, incl	0.015	0.020	0.031	0.062	0.031	0.093	0.062	...	...	0.093	0.062
Over 6 to 8, incl	0.016	0.025	0.031	0.062	0.031	0.093	0.062	0.125	0.156	0.125	0.156
Over 8 to 10, incl	0.021	0.031	0.031	0.062	0.031	0.093	0.062	0.125	0.156	0.156	0.187

Specified Widths, in.	Thickness Tolerances, mm, for Given Thickness										
	3.2 to 12.7, incl	Over 12.7 to 25.4, incl	Over 25.4 to 50.8, incl	Over 50.8 to 101.6, incl		Over 101.6 to 152.4, incl		Over 152.4 to 203.2, incl		Width Tolerance	
				Over	Under	Over	Under	Over	Under	Over	Under
To 25.4, incl	0.20	0.25	...	...	...	...	...	...	...	0.38	0.38
25.4 to 50.8, incl	0.31	0.38	0.80	...	...	...	...	...	...	0.80	0.80
50.8 to 101.6, incl	0.38	0.51	0.80	1.58	0.80	...	...	...	...	1.58	0.80
101.6 to 152.4, incl	0.38	0.51	0.80	1.58	0.80	2.36	1.58	...	...	2.36	1.58
152.4 to 203.2, incl	0.41	0.64	0.80	1.58	0.80	2.36	1.58	3.18	3.96	3.18	3.96
203.2 to 254.0, incl	0.53	0.80	0.80	1.58	0.80	2.36	1.58	3.18	3.96	3.96	4.75

TABLE 6  
PERMISSIBLE VARIATIONS IN SIZE OF COLD-FINISHED ROUND BARS

Specified Size	Size Tolerance (Note 1)					
			Over		Under	
			in.	mm	in.	mm
Over $\frac{1}{2}$ to 1, incl	12.7 to 25.4		0.002	0.05	0.002	0.05
1 to $1\frac{1}{2}$ , incl	25.4 to 38.1		0.0025	0.06	0.0025	0.06
$1\frac{1}{2}$ to 4, incl (Note 3)	38.1 to 101.6		0.003	0.08	0.003	0.08

NOTE 1 — Size tolerances are over and under as shown in the table. Also, rounds can be produced to tolerances all over and nothing under, or all under and nothing over, or any combination of over and under, if the total spread in size tolerance for a specified size is not less than the total spread shown in the table.

NOTE 2 — When it is necessary to heat treat or heat treat and pickle after cold finishing, size tolerances are double those shown in the table.

NOTE 3 — Cold-finished bars over 4 in. (102 mm) in diameter are produced; size tolerances for such bars are not included herein.

TABLE 7  
PERMISSIBLE VARIATIONS IN SIZE OF COLD-FINISHED HEXAGONAL, OCTAGONAL,  
AND SQUARE BARS

Specified Size		Permissible Variations from Specified Size		
		Over	Under	
in.	mm		in.	mm
Over 1/2 to 1, incl	12.7 to 25.4	0	0.004	0.10
Over 1 to 2, incl	25.4 to 50.8	0	0.006	0.15
Over 2 to 4, incl	50.8 to 101.2	0	0.008	0.20
Over 4	101.2	0	0.010	0.25

NOTE — When it is necessary to heat treat or heat treat and pickle after cold finishing, size tolerances are double those shown in the table.

TABLE 8  
PERMISSIBLE VARIATIONS IN WIDTH AND THICKNESS OF COLD-FINISHED FLAT BARS

Width		Width Tolerance (Note 1), Over and Under			
		For Thicknesses 1/4 in. (6.4 mm) and Under		For Thicknesses over 1/4 in. (6.4 mm)	
in.	mm	in.	mm	in.	mm
3/8 to 1, incl	9.5 to 25.4	0.004	0.10	0.002	0.05
Over 1 to 2, incl	25.4 to 50.8	0.006	0.15	0.003	0.08
Over 2 to 3, incl	50.8 to 76.2	0.008	0.20	0.004	0.10
Over 3 to 4 1/2, incl	76.2 to 114.3	0.010	0.25	0.005	0.13

Thickness		Thickness Tolerance, (Note 1) Over and Under	
in.	mm	in.	mm
1/8 to 1, incl	3.18 to 25.4	0.002	0.05
Over 1 to 2, incl	25.4 to 50.8	0.003	0.08
Over 2 to 3, incl	50.8 to 76.2	0.004	0.10
Over 3 to 4 1/2, incl	76.2 to 114.3	0.005	0.13

NOTE 1 — When it is necessary to heat treat or heat treat and pickle after cold finishing, tolerances are double those shown in the table.

NOTE 2 — Cold-finished flat bars over 4 1/2 in. (114.3 mm) wide or thick are produced; width and thickness tolerances for such bars are not included herein.

TABLE 9  
PERMISSIBLE VARIATIONS IN LENGTH OF HOT FINISHED OR COLD FINISHED BARS

Specified Sizes of Rounds, Squares, Hexagons, Octagons and Widths of Flats, <sup>4</sup> in. (mm)	Permissible Variations in Length, in. (mm)				
	To 12 ft (3.66 m), incl		Over 12 to 25 ft (3.66 to 7.62 m), incl		
	Over	Under	Over	Under	
To 2, incl	51	$\frac{1}{2}$ (12.7)	0	$\frac{3}{4}$ (19.1)	0
Over 2 to 4, incl	51 to 102	$\frac{3}{4}$ (19.1)	0	1 (25.4)	0
Over 4 to 6, incl	102 to 152	1 (25.4)	0	$1\frac{1}{4}$ (31.8)	0
Over 6 to 9, incl	152 to 229	$1\frac{1}{4}$ (31.8)	0	$1\frac{1}{2}$ (38.1)	0
Over 9 to 10, incl	229 to 254	$1\frac{1}{2}$ (38.1)	0	2 (50.8)	0

NOTE — Tolerances in this table apply when specific lengths are ordered. When random lengths are ordered, the length range is not less than 24 in. (610 mm).

<sup>4</sup> The maximum width of bar flats is 10 in. (254 mm).

TABLE 10  
PERMISSIBLE VARIATIONS IN LENGTH OF HOT FINISHED OR COLD FINISHED BARS  
MACHINE-CUT AFTER MACHINE STRAIGHTENING

Specified Sizes of Rounds, Squares, Hexagons, Octagons and Widths of Flats, <sup>4</sup> in. (mm)	Permissible Variations in Length, in. (mm)				
	To 12 ft (3.66 m), incl		Over 12 to 25 ft (3.66 to 7.62 m), incl		
	Over	Under	Over	Under	
To 3, incl	76.2	$\frac{1}{8}$ (3.2)	0	$\frac{3}{16}$ (4.8)	0
Over 3 to 6, incl	76.2 to 152.4	$\frac{3}{16}$ (4.8)	0	$\frac{1}{4}$ (6.4)	0
Over 6 to 9, incl	152.4 to 228.6	$\frac{1}{4}$ (6.4)	0	$\frac{5}{16}$ (7.9)	0
Over 9 to 12, incl	228.6 to 304.8	$\frac{1}{2}$ (12.7)	0	$\frac{1}{2}$ (12.7)	0

NOTE — Tolerances in this table apply when specific lengths are ordered. When random lengths are ordered, the length range is not less than 24 in. (610 mm).

<sup>4</sup> The maximum width of bar flats is 10 in. (254 mm).

**TABLE 11  
DIMENSIONAL TOLERANCES—HOT EXTRUSIONS**

Largest Section Dimension, in. (mm)	Tolerance, ±, in. (mm)
Under 1 (25.40)	0.020 (0.51)
1 (25.40) to 3 (76.20), excl	0.031 (0.79)

**TABLE 12  
ANGULARITY TOLERANCE—HOT EXTRUSIONS**

	Tolerance, ±, °
Specified angle or angles	2

**TABLE 13  
LENGTH TOLERANCES FOR SHAPES AND HOT EXTRUSIONS SPECIFIED TO EXACT LENGTHS, MACHINE CUT AFTER STRAIGHTENING**

Largest Sectional Dimension, in. (mm)	Length Tolerance, in. (mm)	
	Over	Under
Up to 3 (76.2), excl	¼ (6.4)	0

**TABLE 14  
PERMISSIBLE VARIATIONS IN STRAIGHTNESS (CAMBER) OF HOT-FINISHED BARS, HOT EXTRUSIONS AND COLD-FINISHED BARS**

Hot-finished bar and hot extrusions:  
 $\frac{1}{8}$  in. (3.2 mm) in any 5 ft (1.5 m), but may not exceed  $(\frac{1}{8} \times \text{No. of feet in length})/5$   
 2.1 mm  $\times$  No. of metres in length  
 Cold-finished bars:  
 $\frac{1}{16}$  in. (1.6 mm) in any 5 ft (1.5 m) but may not exceed  $(\frac{1}{16} \times \text{No. of feet in length})/5$   
 1.05 mm  $\times$  No. of metres in length

NOTE 1 — Measurement is taken on the concave side of the bar with a straightedge and represents the greatest deviation of the side from a straight line.

shown in Test Methods E 8 shall be used. Longitudinal strip specimens shall be prepared in accordance with Test Methods E 8 for rectangular bar up to ½ in. (12.7 mm) inclusive, in thicknesses that are too wide to be pulled full size.

**13. Test Methods**

**13.1 Chemical Composition** — In case of dispute, the chemical analysis shall be made in accordance with Test Methods E 1473.

**13.2 Grain Size** — The measurement of average grain size may be carried out by the planimetric method, the comparison method, or the intercept method described in Test Methods E 112. In case of dispute the “referee” method for determining average grain size shall be the planimetric method.

**13.3 Tension Test** — Test Methods E 8.

**13.4 Rounding Method** — For purposes of determining compliance with the limits in this specification, an observed value or a calculated value shall be rounded as indicated below, in accordance with the rounding method of Practice E 29:

Requirements	Rounded Unit for Observed or Calculated Value
Chemical composition and tolerances (when expressed in decimals)	nearest unit in the right-hand place of figures of the specified limit. If two choices are possible, as when the digits dropped are exactly a 5 or a 5 followed only by zeros, choose the one ending in an even digit with zero defined as an even digit.
Tensile strength and yield strength	nearest 1000 psi (6.9 MPa)
Elongation	nearest 1%
Grain size	
0.0024 in. (0.060 mm) or larger	nearest multiple of 0.0002 in. (0.005 mm)
Less than 0.0024 in. (0.060 mm)	nearest multiple of 0.0001 in. (0.002 mm)

**14. Inspection**

**14.1** Inspection of the material by the purchaser shall be as agreed upon between the purchaser and the supplier as part of the purchase contract.

**15. Rejection and Rehearing**

**15.1** Material that fails to conform to the requirements of this specification may be rejected. Rejection should be reported to the producer or supplier promptly and in writing. In case of dissatisfaction with the results of the test, the producer or supplier may make claim for a rehearing.

**16. Certification**

**16.1** A producer’s or supplier’s certification shall be furnished to the purchaser that the material was manufactured, sampled, tested, and inspected in accordance with this specification and has been found to meet the requirements. A report of the test results shall be furnished.

**17. Packaging and Package Marking**

**17.1** Material shall be bundled or boxed in such a manner as to assure undamaged delivery to its destination when properly transported by a common carrier.

**17.2** Each bundle or shipping container shall be marked with the name of the material or UNS number, heat number,

condition (temper), this specification number, the size, gross, and net weight, consignor and consignee address, and contract or order number.

**18. Keywords**

**18.1** UNS N08330; UNS N08332; bar

ASMENORMDOC.COM : Click to view the full PDF of ASME BPVC.II.B (ASME BPVC Section II part B) 2025

ASMENORMDOC.COM : Click to view the full PDF of ASME BPVC.II.B (ASME BPVC Section II part B) 2025

INTENTIONALLY LEFT BLANK

# SPECIFICATION FOR WELDED NICKEL- IRON-CHROMIUM ALLOY PIPE



**SB-514**

(Identical with ASTM Specification B514-05(2019) except for the deletion of para. 5.1.6.)

ASMENORMDOC.COM : Click to view the full PDF of ASME BPVC.II.B (ASME BPVC Section II part B) 2025

# Specification for Welded Nickel-Iron-Chromium Alloy Pipe

## 1. Scope

1.1 This specification covers nickel-iron-chromium alloys in the form of welded, cold-worked, and annealed pipe for general corrosive service and heat-resisting applications. These products are furnished in three alloys: UNS N08120, UNS N08800, and UNS N08810. Alloy UNS N08800 is employed normally in service temperatures up to and including 1100 °F (593 °C). Alloys UNS N08120 and UNS N08810 are employed normally in service temperatures above 1100 °F where resistance to creep and rupture is required, and are annealed to develop controlled grain size for optimum properties in this temperature range.

1.2 This specification covers outside diameter and nominal wall pipe shown in ANSI B36.19. Pipe having other dimensions may be furnished provided such pipe complies with all other requirements of the specification.

1.3 The values stated in inch-pound units are to be regarded as standard. The values given in parentheses are mathematical conversions to SI units that are provided for information only and are not considered standard.

1.4 *This standard does not purport to address all of the safety concerns, if any, associated with its use. It is the responsibility of the user of this standard to establish appropriate safety, health, and environmental practices and determine the applicability of regulatory limitations prior to use.*

1.5 *This international standard was developed in accordance with internationally recognized principles on standardization established in the Decision on Principles for the Development of International Standards, Guides and Recommendations issued by the World Trade Organization Technical Barriers to Trade (TBT) Committee.*

## 2. Referenced Documents

### 2.1 ASTM Standards:

B775 Specification for General Requirements for Nickel and Nickel Alloy Welded Pipe

B899 Terminology Relating to Non-ferrous Metals and Alloys

### 2.2 ANSI Standard:

B36.19 Stainless Steel Pipe

## 3. Terminology

3.1 Terms defined in Terminology B899 shall apply unless defined otherwise in this standard.

## 4. General Requirement

4.1 Material furnished in accordance with this specification shall conform to the applicable requirements of the current edition of Specification B775 unless otherwise provided herein.

## 5. Ordering Information

5.1 Orders for material under this specification should include the following information:

5.1.1 Alloy name or UNS number.

5.1.2 ASTM designation and year of issue.

5.1.3 Condition (temper) (Table 1).

5.1.4 *Dimensions:*

5.1.4.1 Nominal pipe size or outside diameter and schedule number or nominal wall thickness.

5.1.4.2 Length (specific or random).

5.1.5 Quantity (feet or metres, or number of pieces).

5.1.6 DELETED

5.1.7 *Samples for Product (Check) Analysis*—State whether samples for product (check) analysis should be furnished.

5.1.8 *Purchaser Inspection*—If the purchaser wishes to witness tests or inspection of material at the place of

TABLE 1 Mechanical Property Requirements

Alloy	Condition (Temper)	Tensile Strength, min, psi (MPa)	Yield Strength, 0.2 % Offset, min, psi (MPa)	Elongation in 2 in. or 50 mm, min, %
UNS N08120	annealed	90 000 (621)	40 000 (276)	30
UNS N08800	annealed	75 000 (520)	30 000 (207)	30
UNS N08810	annealed	65 000 (450)	25 000 (170)	30

manufacture, the purchase order must so state indicating which tests or inspections are to be witnessed.

## 6. Materials and Manufacture

6.1 Pipe shall be made from flat-rolled alloy by an automatic welding process with no addition of filler metal. Subsequent to welding and prior to final solution treatment, the material shall be cold worked either in both weld and base metal or in weld metal only.

6.2 Pipe shall be furnished with a scale-free finish. When bright annealing is used, descaling is not necessary.

## 7. Chemical Composition

7.1 The material shall conform to the requirements as to chemical composition prescribed in Table 2.

7.2 If a product (check) analysis is performed by the purchaser, the material shall conform to the product (check) analysis variations in Table 1 of Specification B775.

TABLE 2 Chemical Requirements

Element	Composition Limits, %	
	Alloy N08120	Alloys N08800 and N08810
Nickel	35.0 min	30.0 min
	39.0 max	35.0 max
Chromium	23.0 min	19.0 min
	27.0 max	23.0 max
Iron	remainder	39.5 min <sup>A</sup>
Manganese, max	1.5	1.5 <sup>B</sup>
Carbon	0.02 min	...
	0.10 max	...
Copper, max	0.50 max	0.75
Silicon, max	1.0	1.0
Sulfur, max	0.03	0.015
Aluminum	0.40 max	0.15 min
	...	0.60 max
Titanium	0.20 max	0.15 min
	...	0.60 max
Columbium	0.4 min	...
	0.9 max	...
Molybdenum	2.50 max	...
Phosphorus	0.040 max	...
Tungsten	2.50 max	...
Cobalt, max	3.0	...
Nitrogen	0.15 min	...
	0.30 max	...
Boron	0.010 max	...

<sup>A</sup> Iron shall be determined arithmetically by difference.

<sup>B</sup> Alloy UNS N08800: 0.10 max. Alloy UNS N08810: 0.05 to 0.10.

## 8. Mechanical and Other Requirements

8.1 *Mechanical Properties*—The material shall conform to the requirements for mechanical properties prescribed in Table 1.

8.2 *Grain Size*—A transverse sample representing the full-wall thickness of annealed alloys UNS N08120 and N08810 shall conform to an average grain size of ASTM No. 5 or coarser.

8.3 *Flattening Test*—Pipe shall be capable of withstanding, without cracking, flattening under a load applied gradually at room temperature until the distance between the platens is five times the wall thickness. The weld shall be positioned 90° from the direction of the applied flattening force.

8.4 *Annealing Temperature*—Alloy UNS N08120 shall be annealed at 2150 °F (1177 °C) minimum; alloy UNS N08810 shall be annealed at 2050 °F (1120 °C) minimum.

### 8.5 Nondestructive Test Requirements:

8.5.1 *Category 1*—Each piece of each lot shall be subject to one of the following four tests: hydrostatic, pneumatic (air underwater), eddy current, or ultrasonic.

8.5.2 *Category 2*—Each piece in each lot shall be subjected to a leak test and an electric test as follows:

8.5.2.1 *Leak Test*—Hydrostatic or pneumatic (air underwater).

8.5.2.2 *Electric Test*—Eddy current or ultrasonic.

8.6 The manufacturer shall have the option to test Category 1 or Category 2 and select the nondestructive test methods, if not specified by the purchaser.

8.7 *Transverse Guided Bend Test*—At the option of the pipe manufacturer, the transverse guided bend test may be substituted in lieu of the flattening test. Two bend specimens shall be taken transversely from pipe or the test specimens may be taken from a test plate of the same material and heat as pipe, which is attached to the end of the cylinder and welded as a prolongation of the pipe longitudinal seam. One test is required for each lot as defined in Specification B775.

## 9. Number of Tests

9.1 *Chemical Analysis*—One per lot.

9.2 *Mechanical Properties*—One test per lot.

9.3 *Flattening or Transverse Guided Bend Test*—One test per lot.

9.4 *Grain Size*—One test per lot.

9.5 *Nondestructive*—Each piece in each lot.

## 10. Keywords

10.1 UNS N08120; UNS N08800; UNS N08810; welded pipe

ASMENORMDOC.COM : Click to view the full PDF of ASME BPVC.II.B (ASME BPVC Section II part B) 2025

INTENTIONALLY LEFT BLANK

# SPECIFICATION FOR WELDED UNS N08120, UNS N08800, UNS N08810, AND UNS N08811 ALLOY TUBES



SB-515

(Identical with ASTM Specification B515-95 (2014) except that certification has been made mandatory.)

ASMENORMDOC.COM : Click to view the full PDF of ASME BPVC.II.B (ASME BPVC Section II part B) 2025

# SPECIFICATION FOR WELDED UNS N08120, UNS N08800, UNS N08810, AND UNS N08811 ALLOY TUBES



SB-515

[Identical with ASTM Specification B 515-95(2014) except certification has been made mandatory.]

## 1. Scope

**1.1** This specification covers welded UNS N08120, UNS N08800, UNS N08810 and UNS N08811 alloy boiler, heat exchanger, and condenser tubes for general corrosion resisting and low or high-temperature service.

**1.2** This specification covers tubes  $\frac{1}{8}$  to 5 in. (3.18 to 127 mm), inclusive, in outside diameter and 0.015 to 0.500 in. (0.38 to 12.70 mm), inclusive, in wall thickness. Table 2 of Specification B 751 lists the dimensional requirements of these sizes. Tubes having other dimensions may be furnished provided such tubing complies with all other requirements of this specification.

**1.3** The values stated in inch-pound units are to be regarded as the standard. The SI units given in parentheses are for information only.

**1.4** *This standard does not purport to address all of the safety concerns, if any, associated with its use. It is the responsibility of the user of this standard to become familiar with all hazards including those identified in the appropriate Material Safety Data Sheet for this product/material as provided by the manufacturer, to establish appropriate safety and health practices, and determine the applicability of regulatory limitations prior to use.*

## 2. Referenced Documents

### 2.1 ASTM Standards:

B 751 Specification for General Requirements for Nickel and Nickel Alloy Welded Tube

## 3. Ordering Information

**3.1** Orders for material to this specification should include the following information:

**3.1.1** *Quantity* (feet or number of lengths),

**3.1.2** *UNS Number*,

**3.1.3** *Size* (outside diameter minimum or average wall thickness),

**3.1.4** *Length* (random or specific),

**3.1.5** *Class*,

**3.1.6** *ASTM Designation*,

**3.1.7** *Product Analysis* — State if required,

**3.1.8** *Certification* — Certification and a report of test results are required, and

**3.1.9** *Purchaser Inspection* — State which tests or inspections are to be witnessed, if any.

## 4. Materials and Manufacture

**4.1** Tube shall be made from flat-rolled alloy by an automatic welding process with no addition or filler metal. Subsequent to welding and prior to final annealing, the material shall be cold-worked in either the weld metal only or both weld and base metal.

**4.2** Tube shall be furnished with oxide removed. When bright annealing is used, descaling is not necessary.

## 5. Chemical Composition

**5.1** The material shall conform to the composition limits specified in Table 1. One test is required for each lot as defined in Specification B 751.

**5.2** If a product analysis is performed, it shall meet the chemistry limits prescribed in Table 1, subject to the analysis tolerances specified in Table 6 of Specification B 751.

TABLE 1  
CHEMICAL REQUIREMENTS

Element	Composition Limits, %			
	Alloy N08120	Alloy N08800	Alloy N08810	Alloy N08811
Nickel, min	35.0	30.0	30.0	30.0
Nickel, max	39.0	35.0	35.0	35.0
Chromium, min	23.0	19.0	19.0	19.0
Chromium, max	27.0	23.0	23.0	23.0
Iron, min	remainder	39.5 (A)	39.5 (A)	39.5 (A)
Manganese, max	1.5	1.5	1.5	1.5
Carbon, min	0.02	...	...	...
Carbon, max	0.10	0.10	0.05 to 0.10	0.06 to 0.10
Copper, max	0.50	0.75	0.75	0.75
Silicon, max	1.0	1.0	1.0	1.0
Sulfur, max	0.03	0.015	0.015	0.015
Aluminum, min (B)	...	0.15	0.15	0.15
Aluminum, max	0.40	0.60	0.60	0.60
Titanium, min (B)	...	0.15	0.15	0.15
Titanium, max	0.20	0.60	0.60	0.60
Columbium, min	0.4	...	...	...
Columbium, max	0.9	...	...	...
Molybdenum, max	2.50	...	...	...
Phosphorus, max	0.040	...	...	...
Tungsten, max	2.50	...	...	...
Cobalt, max	3.0	...	...	...
Nitrogen, min	0.15	...	...	...
Nitrogen, max	0.30	...	...	...
Boron, max	0.010	...	...	...

## NOTES:

(A) Iron shall be determined arithmetically by difference.

(B) Alloy UNS N08811: Al + Ti, 0.85–1.20.

TABLE 2  
MECHANICAL PROPERTY REQUIREMENTS

Alloy	Condition (Temper)	Tensile Strength, min, psi (MPa)	Yield Strength, 0.2% Offset, min, psi (MPa)	Elongation in 2 in. or 50 mm, min, %
UNS N08120	annealed	90 000 (621)	40 000 (276)	30
UNS N08800	annealed	75 000 (520)	30 000 (205)	30
UNS N08810 and UNS N08811	annealed	65 000 (450)	25 000 (170)	30

## 6. Mechanical and Other Properties

**6.1 Mechanical Properties**—The material shall conform to the mechanical property requirements specified in Table 2. One test is required for each lot as defined in Specification B 751.

**6.2 Grain Size** — A transverse sample representing the full-wall thickness of annealed alloys UNS N08120, N08810, and N08811 shall conform to an average grain size of ASTM No. 5 or coarser.

**6.3 Flattening Test** — A flattening test shall be made on each end of one tube per lot. Superficial ruptures resulting from surface imperfections shall not be cause for rejection.

**6.4 Flange Test** — A flange test shall be made on each end of one tube per lot.

### 6.5 Nondestructive Test Requirements:

**6.5.1 Class 1** — Each piece of each lot shall be subject to one of the following four tests: hydrostatic, pneumatic (air underwater), eddy current, or ultrasonic.

**6.5.2 Class 2** — Each piece in each lot shall be subjected to a leak test and an electric test as follows:

**6.5.2.1 Leak Test** — Hydrostatic or pneumatic (air underwater).

**6.5.2.2 Electric Test** — Eddy current or ultrasonic.

**6.6** The manufacturer shall have the option to test Class 1 or Class 2 and select the nondestructive test methods, if not specified by the purchaser.

**7. General Requirements**

**7.1** Material furnished under this specification shall conform to the applicable requirements of the current edi-

tion of Specification B 751 unless otherwise provided herein.

**8. Keywords**

**8.1** UNS N08120; UNS N08800; UNS N08810; UNS N08811; welded tube

ASMENORMDOC.COM : Click to view the full PDF of ASME BPVC.II.B (ASME BPVC Section II part B) 2025

**SPECIFICATION FOR WELDED NICKEL-  
CHROMIUM-ALUMINUM ALLOY (UNS N06699) AND  
NICKEL-CHROMIUM-IRON ALLOY (UNS N06600, UNS  
N06601, UNS N06603, UNS N06025, UNS N06045, UNS  
N06690, AND UNS N06693) TUBES**



**SB-516**

(Identical with ASTM Specification B516-18 except that certification and a test report have been made mandatory.)

# Specification for Welded Nickel-Chromium-Aluminum Alloy (UNS N06699) and Nickel-Chromium-Iron Alloy (UNS N06600, UNS N06601, UNS N06603, UNS N06025, UNS N06045, UNS N06690, and UNS N06693) Tubes

## 1. Scope

1.1 This specification covers welded UNS N06600, N06601, N06603, N06025, N06045, UNS N06690, UNS N06693, and UNS N06699 alloy boiler, heat exchanger, and condenser tubes for general corrosion resisting and low or high-temperature service.

1.2 This specification covers tubes  $\frac{1}{8}$  to 5 in. (3.18 to 127 mm), inclusive, in outside diameter and 0.015 to 0.500 in. (0.38 to 12.70 mm), inclusive, in wall thickness. Table 2 of Specification B751 lists the dimensional requirements of these sizes. Tubes having other dimensions may be furnished provided such tubing complies with all other requirements of this specification.

1.3 The values stated in inch-pound units are to be regarded as standard. The values given in parentheses are mathematical conversions to SI units that are provided for information only and are not considered standard.

1.4 *This standard does not purport to address all of the safety concerns, if any, associated with its use. It is the responsibility of the user of this standard to become familiar with all hazards including those identified in the appropriate Safety Data Sheet (SDS) for this product/material as provided by the manufacturer, to establish appropriate safety, health, and environmental practices, and determine the applicability of regulatory limitations prior to use.*

1.5 *This international standard was developed in accordance with internationally recognized principles on standardization established in the Decision on Principles for the Development of International Standards, Guides and Recommendations issued by the World Trade Organization Technical Barriers to Trade (TBT) Committee.*

## 2. Referenced Documents

2.1 *ASTM Standards:*

B751 Specification for General Requirements for Nickel and Nickel Alloy Welded Tube  
B899 Terminology Relating to Non-ferrous Metals and Alloys

## 3. Terminology

3.1 Terms defined in Terminology B899 shall apply unless defined otherwise in this standard.

## 4. Ordering Information

4.1 It is the responsibility of the purchaser to specify all requirements that are necessary for the safe and satisfactory performance of material ordered under this specification. Examples of such requirements include, but are not limited to, the following:

- 4.1.1 Quantity (feet or number of lengths),
- 4.1.2 UNS number,
- 4.1.3 Size (outside diameter minimum or average wall thickness),
- 4.1.4 Length (random or specific),
- 4.1.5 Class,
- 4.1.6 ASTM designation,
- 4.1.7 *Product Analysis*—State if required,
- 4.1.8 *Certification*—Certification and a report of test results are required,
- 4.1.9 *Purchaser Inspection*—State which tests or inspections are to be witnessed, if any.

## 5. Material and Manufacture

5.1 Tube shall be made from flat-rolled alloy by an automatic welding process with no addition or filler metal. Subsequent to welding and prior to final annealing, the material shall be cold-worked in either the weld metal only or both weld and base metal.

TABLE 1 Chemical Requirements

Element	Composition Limits, %							
	N06600	N06601	N06603	N06025	N06045	N06690	N06693	N06699
Nickel <sup>A</sup>	72.0 min	58.0-63.0	Bal	Bal	45.0 min	58.0 min	Bal	Bal
Chromium	14.0 min 17.0 max	21.0-25.0	24.0–26.0	24.0–26.0	26.0–29.0	27.0-31.0	27.0-31.0	26.0-30.0
Iron	6.0 min 10.0 max	Bal <sup>A</sup>	8.0–11.0	8.0–11.0	21.0–25.0	7.0-11.0	2.5-6.0	2.5 max
Manganese	1.0 max	1.0 max	0.15 max	0.15 max	1.0 max	0.5 max	1.0 max	0.50 max
Carbon	0.15 max	0.10 max	20.0-40.0	0.15–0.25	0.05–0.12	0.05 max	0.15 max	0.005-0.10
Copper	0.5 max	1.0 max	0.50 max	0.10 max	0.3 max	0.5 max	0.5 max	0.50 max
Silicon	0.5 max	0.5 max	0.50 max	0.5 max	2.5–3.0	0.5 max	0.5 max	0.50 max
Sulfur	0.015 max	0.015 max	0.010 max	0.010 max	0.010 max	0.015 max	0.01 max	0.01 max
Aluminum	...	1.0-1.7	2.4-3.0	1.8–2.4	...	...	2.5-4.0	1.9-3.0
Titanium	...	...	0.01–0.25	0.1–0.2	...	...	1.0 max	0.60 max
Niobium	...	...	...	...	...	...	0.5-2.5	0.50 max
Phosphorus	...	...	0.020 max	0.02 max	0.02 max	...	...	0.02 max
Zirconium	...	...	0.01–0.40	0.01–0.10	...	...	...	0.10 max
Yttrium	...	...	0.01–0.15	0.05–0.12	...	...	...	...
Cerium	...	...	...	...	0.03–0.09	...	...	...
Nitrogen	...	...	...	...	...	...	...	0.05 max

<sup>A</sup> Element shall be determined arithmetically by difference.

5.2 Tube shall be furnished with oxide removed. When bright annealing is used, descaling is not necessary.

## 6. Chemical Composition

6.1 The material shall conform to the composition limits specified in Table 1. One test is required for each lot as defined in Specification B751.

6.2 If a product analysis is performed, it shall meet the chemistry limits prescribed in Table 1, subject to the analysis tolerances specified in Specification B751.

## 7. Mechanical Properties and Other Requirements

7.1 *Mechanical Properties*—The material shall conform to the mechanical property requirements specified in Table 2. One test is required for each lot as defined in Specification B751.

TABLE 2 Mechanical Property Requirements

Alloy	Tensile Strength min, psi (MPa)	Yield Strength 0.2 % Offset, min, psi (MPa)	Elongation in 2 in. or 50 mm, min, %
N06600	80 000 (550)	35 000 (240)	30
N06601	80 000 (550)	30 000 (205)	30
N06603	94 000 (650)	43 000 (300)	25
N06025	98 000 (680)	39 000 (270)	30
N06045	90 000 (620)	35 000 (240)	30
N06690	85 000 (586)	35 000 (240)	30
N06693	100 000 (690)	50 000 (345)	30
N06699	89 000 (610)	35 000 (240)	40

7.2 *Flattening Test*—A flattening test shall be made on each end of one tube per lot. Superficial ruptures resulting from surface imperfections shall not be cause for rejection.

7.3 *Flange Test*—A flange test shall be made on each end of one tube per lot.

7.4 *Nondestructive Test Requirements:*

7.4.1 *Class 1*—Each piece in each lot shall be subject to one of the following four tests: hydrostatic, pneumatic (air underwater), eddy current, or ultrasonic.

7.4.2 *Class 2*—Each piece in each lot shall be subjected to a leak test and an electric test as follows:

7.4.2.1 *Leak Test*—Hydrostatic or pneumatic (air underwater).

7.4.2.2 *Electric Test*—Eddy current or ultrasonic.

7.5 The manufacturer shall have the option to test to Class 1 or Class 2 and select the nondestructive test methods, if not specified by the purchaser.

## 8. General Requirements

8.1 Material furnished under this specification shall conform to the applicable requirements of the current edition of Specification B751 unless otherwise provided herein.

## 9. Keywords

9.1 welded tube; N06600; N06601; N06603; N06025; N06045; N06690; N06693; N06699

ASMENORMDOC.COM : Click to view the full PDF of ASME BPVC.II.B (ASME BPVC Section II part B) 2025

INTENTIONALLY LEFT BLANK

**SPECIFICATION FOR WELDED NICKEL-  
CHROMIUM-IRON ALLOY (UNS N06600, UNS N06603,  
UNS N06025, AND UNS N06045) PIPE**



**SB-517**

(Identical with ASTM Specification B517-98 except Table 1 was corrected, certification has been made mandatory, and other editorial changes have been made.)

# SPECIFICATION FOR WELDED NICKEL-CHROMIUM-IRON ALLOY (UNS N06600, UNS N06603, UNS N06025, AND UNS N06045) PIPE



SB-517

(Identical with ASTM Specification B 517-98 except Table 1 was corrected, certification has been made mandatory, and other editorial changes have been made.)

## 1. Scope

**1.1** This specification covers welded, cold-worked, and annealed nickel-chromium-iron alloy (UNS N06600, N06603, N06025, and N06045) pipe for general corrosive service and heat-resisting applications.

**1.2** This specification covers outside diameter and nominal wall pipe shown in ANSI B36.19. Pipe having other dimensions may be furnished provided such pipe complies with all other requirements of this specification.

**1.3** The values stated in inch-pound units are to be regarded as the standard.

## 2. Referenced Documents

### 2.1 ASTM Standard

B 775 Specification for General Requirements for Nickel and Nickel Alloy Welded Pipe

### 2.2 ANSI Standard

B36.19 Stainless Steel Pipe

## 3. General Requirement

**3.1** Material furnished in accordance with this specification shall conform to the applicable requirements of the current edition of Specification SB-775 unless otherwise provided herein.

## 4. Ordering Information

**4.1** It is the responsibility of the purchaser to specify all requirements that are necessary for the safe and satisfactory performance of material ordered under this specification. Examples of such requirements include, but are not limited to, the following:

**4.1.1** Alloy name or UNS number.

**4.1.2** ASTM designation and year of issue.

**4.1.3** Condition (temper).

**4.1.4** *Dimensions:*

**4.1.4.1** Nominal pipe size or outside diameter and schedule number or nominal wall thickness.

**4.1.4.2** Length (specific or random).

**4.1.5** Quantity (feet or meters, or number of pieces).

**4.1.6** *Certification* — Certification and a report of test results are required.

**4.1.7** *Samples for Product (Check) Analysis* — State whether samples for product (check) analysis should be furnished.

**4.1.8** *Purchaser Inspection* — If the purchaser wishes to witness tests or inspection of material at the place of manufacture, the purchase order must so state indicating which tests or inspections are to be witnessed.

## 5. Materials and Manufacture

**5.1** Pipe shall be made from flat-rolled alloy by an automatic welding process with no addition of filler metal. Subsequent to welding and prior to final heat treatment, the material shall be cold worked either in both weld and base metal or in weld metal only.

**5.2** Pipe shall be furnished with a scale-free finish. When bright annealing is used, descaling is not necessary.

## 6. Chemical Composition

**6.1** The material shall conform to the requirements as to chemical composition prescribed in Table 1.

TABLE 1  
CHEMICAL REQUIREMENTS

Element	Composition Limits, %				Product (Check) Analysis Variations, Under Min. or Over Max., of the Specified Limit of Element
	N06600	N06603	N06025	N06045	
Nickel <sup>A</sup>	72.0 min.	Bal	Bal	45.0 min.	0.45
Chromium	14.0 min.	24.0–26.0	24.0–26.0	26.0–29.0	0.15
	17.0 max.	...	...	...	0.25
Iron	6.0 min.	8.0–11.0	8.0–11.0	21.0–25.0	0.10
	10.0 max.	...	...	...	0.10
Manganese	1.0	0.15 max.	0.15 max.	1.0 max.	0.03
Carbon	0.15 max.	20.0–40.0	0.15–0.25	0.05–0.12	0.01
Copper	0.5 max.	0.50 max.	0.10 max.	0.3 max.	0.03
Silicon	0.5 max.	0.50 max.	0.5 max.	2.5–3.0	0.03
Sulfur	0.015 max.	0.010 max.	0.010 max.	0.010 max.	0.003
Aluminum	...	2.4–3.0	1.8–2.4	...	...
Titanium	...	0.01–0.25	0.1–0.2	...	...
Phosphorus	...	0.020 max.	0.02 max.	0.02 max.	...
Zirconium	...	0.01–0.40	0.01–0.10	...	...
Yttrium	...	0.01–0.15	0.05–0.12	...	...
Cerium	...	...	...	0.03–0.09	...
Nitrogen	...	...	...	0.05–0.12	...

<sup>A</sup> Nickel shall be determined arithmetically by difference.

**6.2** If a product (check) analysis is performed by the purchaser, the material shall conform to the product (check) analysis variations in Table 1 of Specification SB-775.

TABLE 2  
MECHANICAL PROPERTY REQUIREMENTS

Alloy	Tensile Strength, Min., psi (MPa)	Yield Strength, 0.2% Offset, Min., psi (MPa)	Elongation in 2 in. or 50 mm, Min., %
N06600	80,000 (550)	35,000 (240)	30
N06603	94,000 (650)	43,000 (300)	25
N06025	98,000 (680)	39,000 (270)	30
N06045	90,000 (620)	35,000 (240)	30

## 7. Mechanical and Other Requirements

**7.1 Mechanical Properties** — The material shall conform to the requirements for mechanical properties prescribed in Table 2.

**7.2 Flattening Test** — Pipe shall be capable of withstanding, without cracking, flattening under a load applied gradually at room temperature until the distance between the platens is five times the wall thickness. The weld shall be positioned 90° from the direction of the applied flattening force.

### 7.3 Nondestructive Test Requirements:

**7.3.1 Category 1** — Each piece of each lot shall be subject to one of the following four tests: hydrostatic, pneumatic (air underwater), eddy current, or ultrasonic.

**7.3.2 Category 2** — Each piece in each lot shall be subjected to a leak test and an electric test as follows:

**7.3.2.1 Leak Test** — hydrostatic or pneumatic (air underwater), and

**7.3.2.2 Electric Test** — eddy current or ultrasonic.

**7.4** The manufacturer shall have the option to test Category 1 or Category 2 and select the nondestructive test methods, if not specified by the purchaser.

## 8. Number of Tests

**8.1 Chemical Analysis** — One per lot.

**8.2 Mechanical Properties** — One test per lot.

**8.3 Flattening** — One test per lot.

**8.4 Nondestructive** — Each piece in each lot.

## 9. Keywords

**9.1** welded pipe; N06600; N06603; N06025; N06045

ASMENORMDOC.COM : Click to view the full PDF of ASME BPVC.II.B (ASME BPVC Section II part B) 2025

INTENTIONALLY LEFT BLANK

# SPECIFICATION FOR SEAMLESS AND WELDED ZIRCONIUM AND ZIRCONIUM ALLOY TUBES



**SB-523/SB-523M**



(Identical with ASTM Specification B523/B523M-18.)

ASME BPVC Section II part B) 2025  
ASME BPVC.II.B (ASME BPVC Section II part B) 2025  
ASMENORMDOC.COM : Click to view the full PDF of ASME BPVC.II.B (ASME BPVC Section II part B) 2025

# Specification for Seamless and Welded Zirconium and Zirconium Alloy Tubes

## 1. Scope

1.1 This specification covers two grades of zirconium and zirconium alloy seamless and welded tubes.

1.2 Unless a single unit is used, for example corrosion mass gain in  $\text{mg}/\text{dm}^2$ , the values stated in either inch-pound or SI units are to be regarded separately as standard. Within the text, the SI units are shown in brackets. The values stated in each system are not exact equivalents; therefore, each system shall be used independently of the other. Combining values from the two systems may result in nonconformance with the specification.

1.3 The following precautionary caveat pertains only to the test methods portion of this specification: *This standard does not purport to address all of the safety concerns, if any, associated with its use. It is the responsibility of the user of this standard to establish appropriate safety, health, and environmental practices and determine the applicability of regulatory limitations prior to use.*

1.4 *This international standard was developed in accordance with internationally recognized principles on standardization established in the Decision on Principles for the Development of International Standards, Guides and Recommendations issued by the World Trade Organization Technical Barriers to Trade (TBT) Committee.*

## 2. Referenced Documents

### 2.1 ASTM Standards:

A370 Test Methods and Definitions for Mechanical Testing of Steel Products  
 B551/B551M Specification for Zirconium and Zirconium Alloy Strip, Sheet, and Plate  
 B614 Practice for Descaling and Cleaning Zirconium and Zirconium Alloy Surfaces  
 E8/E8M Test Methods for Tension Testing of Metallic Materials  
 E29 Practice for Using Significant Digits in Test Data to Determine Conformance with Specifications  
 E213 Practice for Ultrasonic Testing of Metal Pipe and Tubing  
 E426 Practice for Electromagnetic (Eddy Current) Examination of Seamless and Welded Tubular Products, Titanium, Austenitic Stainless Steel and Similar Alloys

## 3. Terminology

### 3.1 Definitions of Terms Specific to This Standard:

3.1.1 *annealed, n*—for purposes of this specification “annealed” denotes material that exhibits a recrystallized grain structure.

### 3.2 Lot Definitions:

3.2.1 *tubes, n*—a lot shall consist of a material of the same size, shape, condition, and finish produced from the same ingot or powder blend by the same reduction schedule and the same heat treatment parameters. Unless otherwise agreed between manufacturer and purchaser, a lot shall be limited to the product of an 8 h period for final continuous anneal, or to a single furnace load for final batch anneal.

## 4. Classification

4.1 The tubes are furnished in two grades as follows:

- 4.1.1 *Grade R60702*—Unalloyed zirconium.
- 4.1.2 *Grade R60704*—Zirconium-tin alloy.

## 5. Ordering Information

5.1 Orders for material under this specification should include the following information:

- 5.1.1 Quantity (weight or number of pieces, or both),
- 5.1.2 Name of material (zirconium seamless or welded tube),
- 5.1.3 Dimensions (diameter, wall thickness as either average or minimum, lengths),
- 5.1.4 ASTM designation and year of issue,
- 5.1.5 Grade number (see 4.1), and

5.1.6 Additions to the specification, if required. See 6.3.1, 7.3, 10.1, 12.7.3, 14.1, and 15.1 for additional optional requirements for the purchase order.

NOTE 1—A typical ordering description is as follows: 1000 pieces of seamless zirconium tubes, 2 in. [50 mm] in outside diameter by 0.06 in. [1.5 mm] in average wall thickness by 10 ft [3 m] in length, vacuum annealed, ASTM B523/B523M - 01, Grade R60702.

## 6. Materials and Manufacture

6.1 Seamless tube shall be made by any seamless method that will yield a product meeting the requirements of this specification.

6.2 Welded tube shall be made from sheet or strip meeting the requirements of Specification B551/B551M by an automatic arc-welding process or other method of welding that will yield a product meeting the requirements of this specification. Filler metal shall not be used. Welded tubing shall be supplied as follows:

- 6.2.1 As welded, or
- 6.2.2 As welded and further reduced.

6.3 The tube shall be furnished annealed.

6.3.1 Purchaser shall specify one of the following:

- (a) annealed in air
- (b) annealed in vacuum

## 7. Chemical Composition

7.1 The material shall conform to the requirements as to chemical composition prescribed in Table 1.

7.2 The manufacturer's ingot analysis shall be considered the chemical analysis for tubing, except for hydrogen and nitrogen, which shall be determined on the finished product.

7.3 When requested by the purchaser and stated in the purchase order, a product analysis for any elements listed in Table 1 shall be made on the finished product.

7.3.1 The manufacturer's analysis shall be considered as verified if the check analysis confirms the manufacturer's reported values within the tolerances prescribed in Table 2.

## 8. Tensile Requirements

8.1 The material, as represented by the test specimens, shall conform to the tensile properties prescribed in Table 3.

TABLE 1 Chemical Requirements<sup>A</sup>

Element	Composition, %	
	UNS Grade Designation	
	R60702	R60704
Zirconium + hafnium, min <sup>B</sup>	99.2	97.5
Hafnium, max	4.5	4.5
Iron + chromium	0.2 max	0.2 to 0.4
Tin	...	1.0 to 2.0
Hydrogen, max	0.005	0.005
Nitrogen, max	0.025	0.025
Carbon, max	0.05	0.05
Niobium	...	...
Oxygen, max	0.16	0.18

<sup>A</sup> By agreement between the purchaser and the manufacturer, analysis may be required and limits established for elements and compounds not specified in the table of chemical composition.

<sup>B</sup> The value for zirconium + hafnium, min, is a warranted but not a measured value.

TABLE 2 Permissible Variation in Product Analysis Between Different Laboratories

Element	Permissible Variation in Product Analysis, %
Hydrogen	0.002
Nitrogen	0.01
Carbon	0.01
Hafnium	0.1
Iron + chromium	0.025
Tin	0.05
Niobium	0.05
Oxygen	0.02

TABLE 3 Tensile Requirements

	UNS Grade Designation	
	R60702	R60704
Tensile strength, min, ksi [MPa]	55 [380]	60 [415]
Yield strength, min, ksi [MPa]	30 [205]	35 [240]
Elongation in 2 in. or 50 mm, min, %	16	14

## 9. Permissible Variation in Dimensions

9.1 *Diameter*—At any point (cross section) along the length of the tube, the variation in outside diameter shall not exceed those prescribed in Table 4.

9.2 *Length*—When tubes are ordered cut to length, the length shall be not less than that specified, but a variation of  $\frac{1}{8}$  in. [3.2 mm] will be permitted on tube up to 10 ft [3 m], inclusive. For lengths over 10 ft, an additional over-tolerance of  $\frac{1}{8}$  in. [3.2 mm] for each 10 ft [3 m] or fraction thereof shall be permissible up to  $\frac{1}{2}$  in. [13 mm], maximum.

9.3 *Straightness*—The tube shall be free of bends or kinks and the maximum uniform bow shall not exceed the values shown in Table 5.

9.4 *Squareness of Cut*—The angle of cut of the end of any tube up to  $1\frac{1}{2}$  in. [40 mm] in outside diameter may depart from square not more than 0.016 in./in. [mm/mm].

## 10. Workmanship and Quality Level Requirements

10.1 The finished tube shall be clean and free of foreign material, shall have smooth ends, free of burrs, and shall be free of injurious external and internal imperfections in accordance with standards of acceptability agreed upon between the manufacturer and the purchaser. Minor defects may be removed provided the dimensional tolerances of Table 4 are not exceeded.

## 11. Significance of Numerical Limits

11.1 For the purpose of determining compliance with the specified limits for requirements of the properties listed in the following table, an observed value or a calculated value shall be rounded as indicated in accordance with the rounding methods of Practice E29.

TABLE 4 Permissible Variations in Outside Dimensions Based on Individual Measurements

Outside Diameter, in. [mm]	Diameter Tolerance, in. [mm] <sup>A,B</sup>	Permissible Variations <sup>C</sup> in Wall Thickness, <i>t</i> , %
Under 1 [25], excl	±0.004 [±0.100]	10
Over 1 to 1½ [25 to 40], incl	±0.005 [±0.125]	10
Over 1½ to 2 [40 to 50], incl	±0.006 [±0.150]	10
Over 2 to 2½ [50 to 65], incl	±0.007 [±0.180]	10
Over 2½ to 3½ [65 to 90], incl	±0.010 [±0.250]	10

<sup>A</sup> These permissible variations in outside diameter apply only to tubes as finished at the mill before subsequent swaging, expanding, bending, polishing, or other fabricating operations.

<sup>B</sup> Ovality is the maximum and minimum outside diameter of a tube measured at any one cross section. If the measurement is made with a ring gage, the following formula shall apply: Ovality = specified OD tube + diameter tolerance +0.002 in. [0.05 mm] (length of ring gage, 1 in. [25 mm] × specified tube OD).

<sup>C</sup> When minimum wall tubes are ordered, tolerances are all plus and shall be double the values shown.

TABLE 5 Straightness

Length, ft [m]	Maximum Curvature Depth of Arc
Over 3 to 6 [0.9 to 1.85], incl	⅙ in. [3.2 mm]
Over 6 to 8 [1.8 to 2.5], incl	⅜ in. [5 mm]
Over 8 to 10 [2.5 to 3.0], incl	¼ in. [6.4 mm]
Over 10 [3.0]	¼ in./any 10 ft [2.1 mm/m]

Property	Rounded Unit for Observed or Calculated Value
Chemical composition, and tolerances (when expressed as decimals)	nearest unit in the last right-hand place of figures of the specified limit
Tensile strength and yield strength	nearest 1000 psi [10 MPa]
Elongation	nearest 1 %

## 12. Number of Tests and Retests

12.1 One longitudinal tension test, see 13.1, shall be made from each lot.

12.2 One chemistry test, see 7.2 and 13.8, for hydrogen and nitrogen shall be made from each lot of finished product.

12.3 One flare test, see 13.6, shall be made from each lot.

12.4 One reverse flattening test, see 13.7, shall be made from each lot of welded tubing.

### 12.5 Welded Tubes:

12.5.1 Welded tubes shall be nondestructively tested using the following procedures:

12.5.1.1 Eddy Current Test, see 13.2.

12.5.1.2 Ultrasonic Test, see 13.3.

12.5.1.3 Hydrostatic Test, see 13.4, or pneumatic test, see 13.5.

### 12.6 Seamless Tubes:

12.6.1 Seamless tubes shall be nondestructively tested using the following procedures:

12.6.1.1 Ultrasonic Test, see 13.3.

12.6.1.2 Eddy Current Test, see 13.2, or hydrostatic test, see 13.4, or pneumatic test, see 13.5.

### 12.7 Retests:

12.7.1 If any sample or specimen exhibits obvious surface contamination or improper preparation disqualifying it as a truly representative sample, it shall be discarded and a new sample or specimen substituted.

12.7.2 If the results of any tests of any lot do not conform to the requirements specified, retests shall be made on additional

tubes of double the original number from the same lot, each of which shall conform to the requirements specified.

12.7.3 Retesting after failure of initial retests may be done only with the approval of the purchaser.

## 13. Test Methods

13.1 *Tension Tests*—Conduct the tension test in accordance with Test Methods E8/E8M. Determine the yield strength by the offset (0.2 %) method. Determine the tensile properties using a strain rate of 0.003 to 0.007 in./in. [mm/mm]/min through the yield strength. After the yield strength has been exceeded, the cross-head speed may be increased to approximately 0.05 in./in. [mm/mm]/min to failure.

### 13.2 Eddy Current Testing:

13.2.1 Perform the nondestructive test in accordance with Practice E426, or a purchaser-approved procedure.

13.2.1.1 *Drilled Hole*—The calibration tube shall contain three or more holes, equally spaced circumferentially around the tube and longitudinally separated by a sufficient distance to allow distinct identification of the signal from each hole. The holes shall be drilled radially and completely through the tube wall, with care being taken to avoid distortion of the tube while drilling. The holes shall not be larger than 0.031 in. [0.8 mm] in diameter. As an alternative, the producer may choose to drill one hole and run the calibration standard through the test coil three times, rotating the tube approximately 120° each time. More passes with smaller angular increments may be used, provided testing of the full 360° of the coil is obtained. For welded tubing, if the weld is visible, one of the multiple holes or the single hole shall be drilled in the weld.

### 13.3 Ultrasonic Testing:

13.3.1 For ultrasonic testing, the longitudinal calibration reference notches shall be at the option of the manufacturer, and be any one of the three common notch shapes in accordance with Practice E213. The depth of the notch shall not exceed 10 % of the specified wall thickness of the material or 0.004 in. [0.10 mm], whichever is greater.

13.3.2 Set aside any tubes showing an indication in excess of that obtained from the calibration standard and subject them to rework, retest, or rejection. A tube, therefore, set aside may be further examined for confirmation of the presence of a defect and may be resubmitted for inspection by the same technique if no defect is found. Any tube may also be resubmitted for inspection if reworked so as to remove the

defect within the specified diameter and wall thickness tolerances as prescribe in Table 4.

#### 13.4 Hydrostatic Test:

13.4.1 Each tube, so tested, shall withstand, without showing bulges, leaks, or other defects, an internal hydrostatic pressure that will produce in the tube wall a stress of 50 % of the minimum specified yield strength at room temperature, except as restricted by 13.4.2. Determine the hydrostatic pressure as follows:

$$P = 2St/D \quad (1)$$

where:

$P$  = minimum hydrostatic test pressure, psi [MPa],  
 $S$  = allowable fiber stress of one half the minimum yield strength, psi [MPa],  
 $t$  = wall thickness, in. [mm], and  
 $D$  = outside diameter, in. [mm].

13.4.2 The maximum hydrostatic test pressure shall not exceed 2500 psi [17.2 MPa] for sizes 3 in. [75 mm] and under, or 2800 psi [19.3 MPa] for sizes over 3 in. [75 mm]. Maintain the hydrostatic pressure for not less than 5 s. When requested by the purchaser and so stated in the order, test the tube in sizes 14 in. [350 mm] in diameter and smaller, to one and one half times the specified working pressure, provided the fiber stress corresponding to those test pressures does not exceed one half the minimum specified yield strength of the material as determined by the equation given in 13.4.1. When one and one half times the working pressure exceeds 2800 psi [19.3 MPa], the hydrostatic test pressure shall be a matter of agreement between the manufacturer and the purchaser.

13.5 *Pneumatic Test*—Each tube so tested shall withstand an internal air pressure of 150 psi [1.0 MPa], minimum, for 5 s, minimum, without showing evidence of leakage. Use the test method that permits easy visual detection of any leakage, such as by placing the tube under water or by using the pressure differential method. Any evidence of leakage shall be cause for rejection of that tube.

13.6 *Flare Test*—A section of the annealed tube, approximately 4 in. [100 mm] in length, shall be capable of being flared without cracking visible to the unaided eye. Make the flare with a tool having a 60° included angle until the specified outside diameter has been increased by 15 %.

NOTE 2—Samples of tube supplied in tempers other than annealed may be annealed before testing.

13.7 *Reverse Flattening Test*—Subject welded tube to a reverse flattening test in accordance with Test Methods and Definitions A370. Open and flatten a section of the tube approximately 4 in. [100 mm] long that is slit longitudinally 90° either side of the weld with the weld at the point of maximum bend. No cracking is permitted

13.8 *Chemical Tests*—Conduct the chemical analysis by the standard techniques normally used by the manufacturer.

#### 14. Inspection

14.1 The manufacturer shall inspect the material covered by this specification prior to shipment. If so specified in the

purchase order, the purchaser or his representative may witness the testing and inspection of the material at the place of manufacture. In such cases, the purchaser shall state in his purchase order which tests he desires to witness. The manufacturer shall give ample notice to the purchaser as to the time and place of the designated tests. If the purchaser's representative does not present himself at the time agreed upon for the testing, the manufacturer shall consider the requirement for the purchaser's inspection at the place of manufacture to be waived.

14.2 The manufacturer shall afford the inspector representing the purchaser, without charge, all reasonable facilities to satisfy him that the material is being furnished in accordance with this specification. This inspection shall be so conducted as not to interfere unnecessarily with the operation of the works.

#### 15. Rejection

15.1 Rejection for failure of the material to meet the requirements of this specification shall be reported to the manufacturer. Unless otherwise specified, rejected material may be returned to the manufacturer at the manufacturer's expense, unless the purchaser receives, within three weeks of the notice of rejection, other instructions for disposition.

#### 16. Certification

16.1 A producer or supplier shall furnish the purchaser with a certificate that the material was manufactured, sampled, tested, and inspected in accordance with this specification and has been found to meet the requirements. The certificate shall include a report of the test results.

#### 17. Referee

17.1 In the event of disagreement between the manufacturer and the purchaser on the conformance of the material to the requirements of this specification or any special test specified by the purchaser, a mutually acceptable referee shall perform the tests in question. The results of the referee's testing shall be used in determining conformance of the material to this specification.

#### 18. Product Marking

18.1 Each length of tube ½ in. [13 mm] and larger in outside diameter, manufactured in accordance with this specification shall be marked legibly, either by stenciling, stamping, or rolling, with the manufacturer's private identifying mark, the ASTM designation, method of manufacture, the grade, and heat number. On smaller than ½ in. [13 mm] in outside diameter tubing that is bundled, the same information may be stamped legibly on a metal tag securely attached to each bundle.

#### 19. Packaging and Package Marking

19.1 The tube shall be packaged in such a manner as to assure safe delivery to its destination when properly transported by common carrier.

#### 20. Keywords

20.1 tubes; tubing; zirconium; zirconium alloy

ASMENORMDOC.COM : Click to view the full PDF of ASME BPVC.II.B (ASME BPVC Section II part B) 2025

INTENTIONALLY LEFT BLANK

**SPECIFICATION FOR NICKEL-IRON-  
CHROMIUM-SILICON ALLOYS (UNS N08330 AND  
N08332) SEAMLESS PIPE AND TUBE**



**SB-535**

(Identical with ASTM Specification B535-99 except that certification has been made mandatory.)

ASMENORMDOC.COM : Click to view the full PDF of ASME BPVC.II.B (ASME BPVC Section II part B) 2025

# SPECIFICATION FOR NICKEL-IRON-CHROMIUM-SILICON ALLOYS (UNS N08330 AND N08332) SEAMLESS PIPE AND TUBE



SB-535

(Identical with ASTM Specification B 535-99 except that certification has been made mandatory.)

## 1. Scope

**1.1** This specification covers alloys UNS N08330 and N08332 in the form of hot-finished and cold-finished seamless pipe and tube intended for heat resisting applications and general corrosive service.

**1.2** The values stated in inch-pound units are to be considered as the standard. The values given in parentheses are for information only.

## 2. Referenced Document

**2.1** *ASTM Standard:*

B 829 Specification for General Requirements for Nickel and Nickel Alloy Seamless Pipe and Tube

## 3. General Requirement

**3.1** Material furnished under this specification shall conform to the applicable requirements of Specification B 829 unless otherwise provided herein.

## 4. Ordering Information

**4.1** It is the responsibility of the purchaser to specify all requirements that are necessary for the safe and satisfactory performance of material ordered under this specification. Examples of such requirements include, but are not limited to, the following:

**4.1.1** Alloy name or UNS number,

**4.1.2** ASTM designation and year of issue,

**4.1.3** *Dimensions:*

**4.1.3.1** *Pipe* — Specify standard pipe size and schedule,

**4.1.3.2** *Tube* — Specify outside diameter and nominal or minimum wall,

**4.1.3.3** *Length* (specific or random),

**4.1.4** *Finish:*

**4.1.4.1** *Pipe* — Specify cold-worked or hot-worked,

**4.1.4.2** *Tube* — Specify cold-worked or hot-finished,

**4.1.5** *Quantity* (feet or meters or number of pieces),

**4.1.6** *Certification* — Certification is required,

**4.1.7** *Samples for Product (Check) Analysis* — State whether samples for product analysis should be furnished, and

**4.1.8** *Purchaser Inspection* — If purchaser wishes to witness tests or inspection of material at place of manufacture, the purchase order must so state indicating which test or inspections are to be witnessed.

## 5. Materials and Manufacture

**5.1** *Heat Treatment* — The material shall be furnished in the annealed condition. The final heat treatment of UNS N08330 shall be 1900°F (1040°C) minimum. The final heat treatment of UNS N08332 shall be 2100°F (1150°C) minimum.

## 6. Chemical Composition

**6.1** The material shall conform to the composition limits specified in Table 1.

**6.1.1** A chemical analysis shall be made on each lot of material as described in Specification B 829.

TABLE 1  
CHEMICAL REQUIREMENTS

Element	Composition Limits, %
C	... <sup>A</sup>
Mn	2.00 max
P	0.03 max
S	0.03 max
Si	0.75–1.50
Cr	17.0–20.0
Ni	34.0–37.0
Cu	1.00 max
Pb	0.005 max
Sn	0.025 max
Fe	remainder <sup>B</sup>

<sup>A</sup> Alloy UNS N08330: 0.08 max. Alloy UNS N08332: 0.05–0.10.

<sup>B</sup> Element shall be determined arithmetically by difference.

**6.2** If a product (check) analysis is performed by the purchaser, the material shall conform to the product analysis variations prescribed in Specification B 829.

## 7. Mechanical and Other Properties

**7.1** The material shall conform to the mechanical properties listed in Table 2.

**7.1.1** One tension test shall be made on each lot of material.

**7.2 Grain Size** — Annealed alloy UNS N08332 shall conform to an average grain size of ASTM No. 5 or coarser. One test per lot is required.

**7.3 Flattening Test** — One section of pipe or tube per lot, not less than 2½ in. (63.5 mm) in length, shall be flattened cold between parallel plates in two steps. During the first step, which is test for ductility, no cracks or breaks on the inside, outside, or end surfaces shall occur until the distance between the plates is less than the value  $H$  calculated as follows:

$$H = 1.09 t / (0.09 + t/D) \quad (1)$$

where:

$H$  = distance between parallel plates, in.

$t$  = specified wall thickness, in., and

$D$  = nominal outside diameter, in.

During the second step, which is a test for soundness, the flattening shall be continued until the specimen breaks or the opposite walls of the pipe or tube meet.

## 7.4 Hydrostatic Test:

**7.4.1** Each pipe or tube shall be subjected to the hydrostatic test.

## 8. Dimensions and Permissible Variations

**8.1** The permissible variations in outside diameter for pipe, both cold-finished and hot-finished, are shown in Table 3. Other dimensions and permissible variations are provided in Specification B 829.

## 9. Keywords

**9.1** high-temperature alloy; N08330; N08332; seamless pipe; seamless tube

TABLE 2  
MECHANICAL PROPERTIES

Alloy	Condition	Tensile Strength, min, psi (MPa)	Yield Strength, 0.2% offset, min, psi (MPa)	Elongation in 2 in. or 50 mm, or 4 $D$ , min, %	Hardness <sup>A</sup>
UNS N08330	annealed	70 000 (483)	30 000 (207)	30	70 to 90 HRB
UNS N08332	annealed	67 000 (462)	27 000 (186)	30	65 to 88 HRB

<sup>A</sup> Hardness values are informative only and not to be construed as the basis for acceptance.

TABLE 3  
 PERMISSIBLE VARIATIONS IN OUTSIDE DIAMETER,  
 HOT-FINISHED AND COLD-FINISHED PIPE

Nominal Pipe Size, in.	Permissible Variations in Outside Diameter			
	Over		Under	
	in.	mm	in.	mm
$\frac{1}{8}$ to $1\frac{1}{2}$ , incl	$\frac{1}{64}$	0.4	$\frac{1}{32}$	0.8
Over $1\frac{1}{2}$ to 4, incl	$\frac{1}{32}$	0.8	$\frac{1}{32}$	0.8
Over 4 to 8, incl	$\frac{1}{16}$	1.6	$\frac{1}{32}$	0.8
Over 8 to 18, incl	$\frac{3}{32}$	2.4	$\frac{1}{32}$	0.8

ASMENORMDOC.COM : Click to view the full PDF of ASME BPVC.II.B (ASME BPVC Section II part B) 2025

# SPECIFICATION FOR NICKEL-IRON- CHROMIUM-SILICON ALLOYS (UNS N08330 AND N08332) PLATE, SHEET, AND STRIP



**SB-536**



(Identical with ASTM Specification B536-95.)

ASMENORMDOC.COM : Click to view the full PDF of ASME BPVC.II.B (ASME BPVC Section II part B) 2025

# SPECIFICATION FOR NICKEL-IRON-CHROMIUM-SILICON ALLOYS (UNS N08330 AND N08332) PLATE, SHEET, AND STRIP



SB-536



(Identical with ASTM Specification B 536-95.)

## 1. Scope

**1.1** This specification covers nickel-iron-chromium-silicon alloys (UNS N08330 and UNS N08332) plate, sheet, and strip intended for heat resisting applications and general corrosive service.

**1.2** The values stated in inch-pound units are to be regarded as the standard. The values given in parentheses are for information only.

## 2. Referenced Documents

### 2.1 ASTM Standards:

- E 8 Test Methods for Tension Testing of Metallic Materials
- E 10 Test Method for Brinell Hardness of Metallic Materials
- E 18 Test Methods for Rockwell Hardness and Rockwell Superficial Hardness of Metallic Materials
- E 29 Practice for Using Significant Digits in Test Data to Determine Conformance with Specifications
- E 38 Methods for Chemical Analysis of Nickel-Chromium and Nickel-Chromium-Iron Alloys
- E 112 Test Methods for Determining the Average Grain Size
- E 140 Standard Hardness Conversion Tables for Metals (Relationship Between Brinell Hardness, Vickers Hardness, Rockwell Hardness, Rockwell Superficial Hardness, and Knoop Hardness)
- E 353 Test Methods for Chemical Analysis of Stainless, Heat-Resisting, Maraging, and Other Similar Chromium-Nickel-Iron Alloys

## 3. Terminology

### 3.1 Descriptions of Terms Specific to This Standard:

**3.1.1 plate** — material  $\frac{3}{16}$  in. (4.76 mm) and over in thickness and over 10 in. (254 mm) in width.

**3.1.2 sheet** — material under  $\frac{3}{16}$  in. (4.76 mm) in thickness and 24 in. (610 mm) in width.

**3.1.3 strip** — material under  $\frac{3}{16}$  in. (4.76 mm) in thickness and under 24 in. (610 mm) in width.

## 4. Ordering Information

**4.1** Orders for material to this specification shall include the following information:

- 4.1.1 Quantity** (weight or number of pieces),
- 4.1.2 Alloy** (Table 1),
- 4.1.3 Form** (plate, sheet or strip),
- 4.1.4 ASTM designation and year of issue,**
- 4.1.5 Dimensions** — Thickness, width, and length,
- 4.1.6 Edge** (for strip only),
- 4.1.7 Finish** (Appendix) for sheet specify whether one or both sides are to be polished,
- 4.1.8 Certification** — State if certification is required (Section 15),
- 4.1.9 Samples for Product (Check) Analysis** — State whether samples for product (check) analysis should be furnished, and
- 4.1.10 Purchaser Inspection** — If purchaser wishes to witness tests or inspections of material at place of manufacture, the purchase order must so state indicating which tests or inspections are to be witnessed.

## 5. Chemical Composition

**5.1** The material shall conform to the requirements as to chemical composition specified in Table 2.

TABLE 1  
MECHANICAL PROPERTIES

Alloy	Condition	Tensile Strength, min, psi (MPa)	Yield Strength, 0.2% offset, min, psi (MPa)	Elongation in 2 in. or 50 mm, or 4D, min, %	Hardness <sup>A</sup>
UNS N08330	annealed	70 000 (483)	30 000 (207)	30	70 to 90 HRB
UNS N08332	annealed	67 000 (462)	27 000 (186)	30	65 to 88 HRB

<sup>A</sup> Hardness values are informative only and not to be construed as the basis for acceptance.

TABLE 2  
CHEMICAL REQUIREMENTS

Element	Composition Limits, %	Product (Check) Analysis Variations, under min or over max of the specified limit of element
C	... <sup>A</sup>	0.01
Mn	2.00 max	0.04
P	0.03 max	0.005
S	0.03 max	0.005
Si	0.75–1.50	0.05 under; 0.10 over
Cr	17.0–20.0	0.25
Ni	34.0–37.0	0.30
Cu	1.00 max	0.04
Pb	0.005 max	...
Sn	0.025 max	...
Fe	remainder <sup>B</sup>	...

<sup>A</sup> Alloy UNS N08330: 0.08 max

Alloy UNS N08332: 0.05–0.10

<sup>B</sup> Element shall be determined arithmetically by difference.

**5.2** If a product (check) analysis is performed by the purchaser, the material shall conform to the product (check) analysis variations in Table 2.

## 6. Mechanical and Other Properties

**6.1** The tensile properties of the material at room temperature shall conform to those shown in Table 1.

**6.2 Grain Size** — Annealed alloy UNS N08332 shall conform to an average grain size of ASTM No. 5 or coarser.

**6.3 Annealing Temperature** — Alloy UNS N08330 shall be annealed at 1900°F (1040°C) minimum. Alloy UNS N08332 shall be annealed at 2100°F (1150°C) minimum.

## 7. Permissible Variations in Dimensions and Weight

**7.1 Sheet**, shall conform to the variations in dimensions specified in Tables 3 to 8, inclusive.

**7.2 Cold-Rolled Strip**, shall conform to the permissible variations in dimensions as specified in Tables 9 to 13, inclusive.

TABLE 3  
THICKNESS TOLERANCES FOR HOT-ROLLED AND  
COLD-ROLLED SHEETS

Specified Thickness, in. (mm)	Tolerance Over and Under, in. (mm)
Over 0.145 to less than $\frac{3}{16}$ (3.68 to less than 4.76)	0.014 (0.36)
Over 0.130 to 0.145 (3.30 to 3.68), incl	0.012 (0.30)
Over 0.114 to 0.130 (2.90 to 3.30), incl	0.010 (0.25)
Over 0.098 to 0.114 (2.49 to 2.90), incl	0.009 (0.23)
Over 0.083 to 0.098 (2.11 to 2.49), incl	0.008 (0.20)
Over 0.072 to 0.083 (1.83 to 2.11), incl	0.007 (0.18)
Over 0.058 to 0.072 (1.47 to 1.83), incl	0.006 (0.15)
Over 0.040 to 0.058 (1.02 to 1.47), incl	0.005 (0.13)
Over 0.026 to 0.040 (0.66 to 1.02), incl	0.004 (0.10)
Over 0.016 to 0.026 (0.41 to 0.66), incl	0.003 (0.08)
Over 0.007 to 0.016 (0.18 to 0.41), incl	0.002 (0.05)
Over 0.005 to 0.007 (0.13 to 0.18), incl	0.0015 (0.04)
0.005 (0.13)	0.001 (0.03)

TABLE 4  
PERMISSIBLE VARIATIONS IN WIDTH AND LENGTH  
FOR HOT-ROLLED AND COLD-ROLLED RESQUARED  
SHEETS (Stretcher Leveled Standard of Flatness)

Specified Dimensions, in. (mm)	Tolerances		
	Over	mm	Under
For thicknesses under 0.131 (3.33):			
Widths up to 48 (1219) excl	$\frac{1}{16}$	1.6	0
Widths 48 (1219) and over	$\frac{1}{8}$	3.2	0
Lengths up to 120 (3048) excl	$\frac{1}{16}$	1.6	0
Lengths 120 (3048) and over	$\frac{1}{8}$	3.2	0
For thicknesses 0.131 (3.33) and over:			
All widths and lengths	$\frac{1}{4}$	6.4	0

**7.3 Plate**, shall conform to the permissible variations in dimensions specified in Tables 14 to 20, inclusive.

**7.4 Sheet Strip, and Plate** — Material with No. 1 finish may be ground to remove surface defects, provided such grinding does not reduce the thickness, width or length at any point beyond the permissible variations in dimensions.

TABLE 5  
WIDTH, LENGTH, AND CAMBER TOLERANCES FOR  
HOT-ROLLED AND COLD-ROLLED SHEETS NOT  
RESQUARED OR STRETCHER LEVELED WIDTH  
TOLERANCES

Specified Thickness, in. (mm)	Tolerance for Specified Width, in. (mm)	
	24 to 48 (610 to 1220), excl	48 in., (1220) and over
Less than $\frac{3}{16}$ (4.76)	$\frac{1}{16}$ (1.6) over, 0 under	$\frac{1}{8}$ (3.2) over, 0 under
Length Tolerances		
Specified Length, ft (cm)	Tolerance, in. (mm)	
	Over	Under
Up to 10 (305), incl	$\frac{1}{4}$ (6.4)	0 (0)
Over 10 to 20 (305 to 610), incl	$\frac{1}{2}$ (12.7)	0 (0)
Camber Tolerances <sup>A</sup>		
Specified Width, in. (mm)	Tolerance per Unit length of any 8 ft (244 cm), in. (mm)	
24 to 36 in. (610 to 914), incl	$\frac{1}{8}$ (3.2)	
Over 36 in. (914)	$\frac{3}{32}$ (2.4)	

<sup>A</sup> Camber is the greatest deviation of a side edge from a straight line, and measurement is taken by placing an 8-ft (2440-mm) straightedge *on the concave side* and measuring the greatest distance between the sheet edge and the straightedge.

## 8. Workmanship, Finish, and Appearance

**8.1** The material shall be uniform in quality and temper, smooth, commercially straight or flat and free of injurious imperfections.

## 9. Sampling

**9.1** Lot — Definition:

**9.1.1** A lot for chemical analysis shall consist of one heat.

**9.1.2** A lot for mechanical properties, hardness, and grain size testing shall consist of all material from the same heat, nominal thickness, and condition.

**9.1.2.1** Where material cannot be identified by heat, a lot shall consist of not more than 500 lb (227 kg) of material in the same thickness and condition, except that for plates weighing over 500 lb only one specimen shall be taken.

**9.2** Test Material Selection:

**9.2.1** Chemical Analysis — Representative samples from each lot shall be taken during pouring or subsequent processing.

**9.2.1.1** Product (check) analysis shall be wholly the responsibility of the purchaser.

**9.2.2** Mechanical Properties and Grain Size — Samples of the material to provide specimens for mechanical properties and grain size shall be taken from such locations in each lot as to be representative of that lot.

## 10. Number of Tests

**10.1** Chemical Analysis — One test per lot.

**10.2** Grain Size — One test per lot.

**10.3** Tensile Properties, Hardness and Bend Test — One test per lot.

## 11. Specimen Preparation

**11.1** Tension test, bend test, and grain size specimens shall be taken from material in the final condition (temper). Tension tests shall be transverse to the direction of rolling, where width will permit.

**11.2** Tension test specimens shall be any of the standard or subsized specimens shown in Test Methods E 8.

**11.3** In the event of disagreement, referee specimens shall be as follows:

**11.3.1** Full thickness of the material, machine to the form and dimensions shown for the sheet-type specimen in Test Methods E 8 for material under  $\frac{1}{2}$  in. (12.7 mm) in thickness.

**11.3.2** The largest possible round specimen shown in Test Methods E 8 for material  $\frac{1}{2}$  in. (12.7 mm) and over.

## 12. Methods of Test

**12.1** Chemical Composition — In case of disagreement, the chemical composition shall be determined in accordance with Test Methods E 353 except, Methods E 38 are to be used for elements not covered by Methods E 353.

**12.2** Tension Test — Tension testing shall be conducted in accordance with Test Methods E 8.

**12.3** Grain Size — The measurement of average grain size may be carried out by the planimetric method, the comparison method, or the intercept method described in Methods E 112. In case of dispute, the “referee” method for determining average grain size shall be the planimetric method.

**12.4** Rockwell Hardness — Test Method E 18.

**12.5** Brinell Hardness — Test Method E 10.

**12.6** Hardness Conversion — Hardness Conversion Tables E 140.

**12.7** Rounding Method — For purposes of determining compliance with the limits in this specification, an observed

TABLE 6  
FLATNESS TOLERANCES FOR HOT-ROLLED AND COLD-ROLLED SHEETS

Sheets Not Specified to Stretcher Level Standard of Flatness			
Specified Thickness, in. (mm)	Width, in. (mm)	Flatness Tolerance (max Deviation from a Horizontal Flat Surface), in. (mm)	
0.062 (1.57) and over	To 60 (1524), incl	$\frac{1}{2}$ (12.7)	
	Over 60 to 72 (1524 to 1829), incl	$\frac{3}{4}$ (19.1)	
	Over 72 (1829)	1 (25.4)	
Under 0.062 (1.57)	To 36 (914), incl	$\frac{1}{2}$ (12.7)	
	Over 36 to 60 (914 to 1524), incl	$\frac{3}{4}$ (19.1)	
	Over 60 (1524)	1 (25.4)	
Sheets Specified to Stretcher Level Standard of Flatness			
Specified Thickness in. (mm)	Width, in. (mm)	Length, in. (mm)	Flatness Tolerance in. (mm)
Under $\frac{3}{16}$ (4.76)	To 48 (1220), incl	To 96 (2440), incl	$\frac{1}{8}$ (3.2)
Under $\frac{3}{16}$ (4.76)	To 48 (1220), incl	Over 96 (2440)	$\frac{1}{4}$ (6.4)
Under $\frac{3}{16}$ (4.76)	Over 48 (1220)	To 96 (2440), incl	$\frac{1}{4}$ (6.4)
Under $\frac{3}{16}$ (4.76)	Over 48 (1220)	Over 96 (2440)	$\frac{1}{4}$ (6.4)

TABLE 7  
DIAMETER TOLERANCES FOR HOT-ROLLED AND  
COLD-ROLLED SHEETS, SHEARED CIRCLES

Specified Thickness, in. (mm)	Tolerance Over Specified Diameter (No Tolerance Under) in. (mm)		
	Under 30 (760)	30 to 48 (760 to 1220), incl	Over 48 (1220)
Over 0.097 (2.46)	$\frac{1}{8}$ (3.2)	$\frac{3}{16}$ (4.8)	$\frac{1}{4}$ (6.4)
Over 0.057 to 0.097 (1.45 to 2.46), incl	$\frac{3}{32}$ (2.4)	$\frac{5}{32}$ (4.0)	$\frac{7}{32}$ (5.6)
0.057 (1.45) and under	$\frac{1}{16}$ (1.6)	$\frac{1}{8}$ (3.2)	$\frac{3}{16}$ (4.8)

TABLE 8  
WEIGHT TOLERANCES FOR HOT-ROLLED AND COLD-  
ROLLED SHEETS

It is not practicable to produce hot-rolled and cold-rolled sheets to exact theoretical weight. Sheets of any one item of a specified thickness and size in any finish may be overweight to the following extent:

- (1) An item of five sheets or less, or an item estimated to weigh 200 lb (90 kg) or less, may actually weigh as much as 10 percent over the theoretical weight.
- (2) An item of more than five sheets and estimated to weigh more than 200 lb (90 kg) may actually weigh as much as 7½ percent over the theoretical weight.
- (3) The underweight variations for sheets are limited by the under thickness tolerances shown in Table 3.

For determining theoretical weight the factor, 42 lb/ft<sup>2</sup> · in. (0.0008 kg/cm<sup>2</sup> · mm) thickness may be used.

TABLE 9  
THICKNESS TOLERANCES FOR COLD-ROLLED STRIP IN COILS AND CUT LENGTHS

Specified thickness, in. (mm), incl	Thickness Tolerances, in. (mm), for the Thicknesses and Widths given, over and under		
	Width, in. (mm)		
	$\frac{3}{16}$ (4.8) to 6 (152), incl	Over 6 (152) to 12 (305), incl	Over 12 (305) to 24 (610), excl
0.005 (0.13) to 0.010 (0.25)	10%	10%	10%
Over 0.010 (0.25) to 0.011 (0.28)	0.0015 (0.04)	0.0015 (0.04)	0.0015 (0.04)
Over 0.011 (0.28) to 0.013 (0.33)	0.0015 (0.04)	0.0015 (0.04)	0.002 (0.05)
Over 0.013 (0.33) to 0.017 (0.43)	0.0015 (0.04)	0.002 (0.05)	0.002 (0.05)
Over 0.017 (0.43) to 0.020 (0.51)	0.0015 (0.04)	0.002 (0.05)	0.0025 (0.06)
Over 0.020 (0.51) to 0.029 (0.74)	0.002 (0.05)	0.0025 (0.06)	0.0025 (0.06)
Over 0.029 (0.74) to 0.035 (0.89)	0.002 (0.05)	0.003 (0.08)	0.003 (0.08)
Over 0.035 (0.89) to 0.050 (1.27)	0.0025 (0.06)	0.0035 (0.09)	0.0035 (0.09)
Over 0.050 (1.27) to 0.069 (1.75)	0.003 (0.08)	0.0035 (0.09)	0.0035 (0.09)
Over 0.069 (1.75) to 0.100 (2.54)	0.003 (0.08)	0.004 (0.10)	0.005 (0.13)
Over 0.100 (2.54) to 0.125 (3.18)	0.004 (0.10)	0.0045 (0.11)	0.005 (0.13)
Over 0.125 (3.18) to 0.161 (4.09)	0.0045 (0.11)	0.0045 (0.11)	0.005 (0.13)
Over 0.161 (4.09) to $\frac{3}{16}$ (4.76) excl	0.005 (0.13)	0.005 (0.13)	0.006 (0.15)

NOTE 1 — Thickness measurements are taken at least  $\frac{3}{8}$  in. (9.5 mm) in from edge of the strip, except that on widths less than 1 in. (25.4 mm) the tolerances are applicable for measurements at all locations.

NOTE 2 — Above tolerances include crown.

TABLE 10  
WIDTH TOLERANCES COLD-ROLLED STRIP IN COILS AND CUT LENGTHS, EDGE NUMBERS 1 AND 5

Specified Edge No.	Width, in. (mm)	Thickness, in. (mm)	Width Tolerance, in. (mm) for
			Thickness and Width given over and under
1 and 5	$\frac{9}{32}$ (7.1) and under	$\frac{1}{16}$ (1.6) and under	0.005 (0.13)
1 and 5	Over $\frac{9}{32}$ (7.1) to $\frac{3}{4}$ (19.1) incl	$\frac{3}{32}$ (2.4) and under	0.005 (0.13)
1 and 5	Over $\frac{3}{4}$ (19.1) to 5 (127) incl	$\frac{1}{8}$ (3.2) and under	0.005 (0.13)
5	Over 5 (127) to 9 (229) incl	$\frac{1}{8}$ (3.2) to 0.008 (0.20) incl	0.010 (0.25)
5	Over 9 (229) to 20 (508) incl	0.105 (2.67) to 0.015 (0.38) incl	0.010 (0.25)
5	Over 20 (508) to 24 (610) excl	0.080 (2.03) to 0.023 (0.58) incl	0.015 (0.38)

TABLE 11  
WIDTH TOLERANCES COLD-ROLLED STRIP IN COILS AND CUT LENGTHS EDGE NUMBER 3

Specified Thickness in. (mm)	Width Tolerance, in. (mm) Over and Under, for Thickness and Width Given					
	Under $\frac{1}{2}$	$\frac{1}{2}$ (12.7) to	Over 6	Over 9	Over 12	Over 20
	(12.7) to $\frac{3}{16}$ (4.8)	6 (152)	(152) to 9 (229)	(229) to 12 (305)	(305) to 20 (508)	(508) to 24 (610)
0.068 (1.73) and under	0.005 (0.13)	0.005 (0.13)	0.005 (0.13)	0.010 (0.25)	0.016 (0.41)	0.020 (0.51)
Over 0.068 (1.75) to 0.099 (2.51), incl	0.008 (0.20)	0.008 (0.20)	0.010 (0.25)	0.010 (0.25)	0.016 (0.41)	0.020 (0.51)
Over 0.099 (2.51) to 0.160 (4.06), incl	0.010 (0.25)	0.010 (0.25)	0.016 (0.41)	0.016 (0.41)	0.020 (0.51)	0.020 (0.51)
Over 0.160 (4.06) to under $\frac{3}{16}$ (4.76) excl	...	0.016 (0.41)	0.020 (0.51)	0.020 (0.51)	0.031 (0.79)	0.031 (0.79)

TABLE 12  
LENGTH TOLERANCES COLD-ROLLED STRIP IN CUT LENGTHS

Specified Length, in. (mm)	Tolerance, in. (mm) Over Specified Length, No Tolerance Under
Up to 60 (1524) incl	$\frac{3}{8}$ (9.5)
Over 60 (1524) to 120 (3048) incl	$\frac{1}{2}$ (12.7)
Over 120 (3048) to 240 (6096) incl	$\frac{5}{8}$ (15.9)

TABLE 13  
CAMBER TOLERANCES COLD-ROLLED STRIP IN COILS AND CUT LENGTHS

Specified Width, in. (mm)	Tolerance in. (mm) per unit Length of any 8 ft. (2440 mm)
Up to $1\frac{1}{2}$ (38.1) incl	$\frac{1}{2}$ (12.7)
Over $1\frac{1}{2}$ (38.1) to 24 (609.6) excl	$\frac{1}{4}$ (6.4)

NOTE — Camber is the deviation of a side edge from a straight line, and measurement is taken by placing an 8-ft (24-mm) straight edge on the concave side and measuring the greatest distance between the strip edge and the straight edge.

TABLE 14  
PERMISSIBLE VARIATIONS IN THICKNESS FOR PLATES<sup>4</sup>

Specified Thickness, in. (mm)	Width, in. (mm)			
	To 84 (2134), incl	Over 84 (2134) to 120 (3048), incl	Over 120 (3048) to 144 (3658), incl	Over 144 (3658)
	Tolerance Over Specified Thickness, <sup>5</sup> in. (mm)			
$\frac{1}{16}$ (4.76) to $\frac{3}{8}$ (9.52), excl	0.045 (1.14)	0.050 (1.27)	...	...
$\frac{3}{8}$ (9.52) to $\frac{3}{4}$ (19.05), excl	0.055 (1.40)	0.060 (1.52)	0.075 (1.90)	0.090 (2.29)
$\frac{3}{4}$ (19.05) to 1 (25.40), excl	0.060 (1.52)	0.065 (1.65)	0.085 (2.16)	0.100 (2.54)
1 (25.40) to 2 (50.80), excl	0.070 (1.78)	0.075 (1.90)	0.095 (2.41)	0.115 (2.92)
2 (50.80) to 3 (76.20), excl	0.125 (3.18)	0.150 (3.81)	0.175 (4.44)	0.200 (5.08)
3 (76.20) to 4 (101.6), excl	0.175 (4.44)	0.210 (5.33)	0.245 (6.22)	0.280 (7.11)

<sup>4</sup> Thickness is measured along the longitudinal edges of the plate at least  $\frac{3}{8}$  in. (9.52 mm), but not more than 3 in. (76.20 mm), from the edge.

<sup>5</sup> For circles, the over thickness tolerances in this table apply to the diameter of the circle corresponding to the width ranges shown. For plates of irregular shape, the over thickness tolerances apply to the greatest width corresponding to the width ranges shown. For plates up to 10 in. (254.0 mm), incl, in thickness, the tolerance under the specified thickness is 0.010 in. (0.25 mm).

TABLE 15  
WIDTH AND LENGTH TOLERANCES FOR PLATES<sup>A, B</sup>

		Tolerance Over Specified Width and Length for Given Width, Length, and Thickness, in.					
Width, in.	Length, in.	Under 3/8 in.		3/8 to 1/2 in., incl, in Thickness		Over 1/2 in. in Thickness	
		Width	Length	Width	Length	Width	Length
48 and under	144 and under	1/8	3/16	3/16	1/4	5/16	3/8
Over 48 to 60, incl		3/16	1/4	1/4	5/16	3/8	7/16
Over 60 to 84, incl		1/4	5/16	5/16	3/8	1/2	1/2
Over 84 to 108, incl		5/16	3/8	3/8	7/16	1/2	9/16
Over 108		3/8	7/16	7/16	1/2	5/8	11/16
48 and under	over 144 to 240	3/16	3/8	1/4	1/2	5/16	5/8
Over 48 to 60, incl		1/4	5/16	5/16	3/8	3/8	3/4
Over 60 to 84, incl		3/8	1/2	7/16	11/16	1/2	3/4
Over 84 to 108, incl		7/16	9/16	1/2	3/4	5/8	7/8
Over 108		1/2	5/8	5/8	7/8	11/16	1
48 and under	over 240 to 360	1/4	1/2	5/16	5/8	3/8	3/4
Over 48 to 60, incl		5/16	5/8	3/8	3/4	5/8	3/4
Over 60 to 84, incl		7/16	11/16	1/2	3/4	5/8	7/8
Over 84 to 108, incl		9/16	3/4	5/8	7/8	3/4	1
Over 108		5/8	7/8	11/16	1	7/8	1
60 and under	over 360 to 480	7/16	1 1/8	1/2	1 1/4	5/8	1 3/8
Over 60 to 84, incl		1/2	1 1/4	5/8	1 1/8	3/4	1 1/2
Over 84 to 108, incl		9/16	1 1/4	3/4	1 3/8	7/8	1 1/2
Over 108		3/4	1 3/8	7/8	1 1/2	1	1 5/8
60 and under	over 480 to 600	7/16	1 1/4	1/2	1 1/2	5/8	1 5/8
Over 60 to 84, incl		1/2	1 3/8	5/8	1 1/2	3/4	1 5/8
Over 84 to 108, incl		5/8	1 3/8	3/4	1 1/2	7/8	1 5/8
Over 108		3/4	1 3/4	7/8	1 5/8	1	1 3/4
60 and under	over 600	1/2	1 3/4	5/8	1 7/8	3/4	1 7/8
Over 60 to 84, incl		5/8	1 3/4	3/4	1 7/8	7/8	1 7/8
Over 84 to 108, incl		5/8	1 3/4	3/4	1 7/8	7/8	1 7/8
Over 108		7/8	1 3/4	1	2	1 1/8	2 1/4

		Tolerance Over Specified Width and Length for Given Width, Length, and Thickness, mm					
Width, mm	Length, mm	Under 9.5 mm		9.5 to 12.7 mm, incl in Thickness		Over 12.7 mm in Thickness	
		Width	Length	Width	Length	Width	Length
1219 mm and under		3.2	4.8	4.8	6.4	7.9	9.5
Over 1219 to 1524, incl	3658 and under	4.8	6.4	6.4	7.9	9.5	11.1
Over 1524 to 2134, incl		6.4	7.9	7.9	9.5	11.1	12.7
Over 2134 to 2743, incl		7.9	9.5	9.5	11.1	12.7	14.3
Over 2743		9.5	11.1	11.1	12.7	15.9	17.5
1219 mm and under		4.8	9.5	6.4	12.7	7.9	15.9
Over 1219 to 1524, incl	over 3658 to 6096	6.4	11.1	7.9	15.9	9.5	19.1
Over 1524 to 2134, incl		9.5	12.7	11.1	17.5	12.7	19.1
Over 2134 to 2743, incl		11.1	14.3	12.7	19.1	15.9	22.2
Over 2743, incl		12.7	15.9	15.9	22.2	17.5	25.4
1219 mm and under		6.4	12.7	7.9	15.9	9.5	19.1
Over 1219 to 1524, incl	over 6096 to 9144	7.9	15.9	9.5	19.1	12.7	19.1
Over 1524 to 2134, incl		11.1	17.5	12.7	19.1	15.9	22.2
Over 2134 to 2743, incl		14.3	19.1	15.9	22.2	19.1	25.4
Over 2743, incl		15.9	22.2	17.5	25.4	22.2	25.4
1524 mm and under		11.1	28.6	12.7	31.8	15.9	34.9
Over 1524 to 2134, incl	over 9144 to 12192	12.7	31.8	15.9	34.9	19.1	38.1
Over 2134 to 2743, incl		14.3	31.8	19.1	34.9	22.2	38.1
Over 2743		19.1	34.9	22.2	38.1	25.4	41.3
1524 mm and under		11.1	31.8	12.7	38.1	15.9	41.3
Over 1524 to 2134, incl	over 12192 to 15240	12.7	34.9	15.9	38.1	19.1	41.3
Over 2134 to 2743, incl		15.9	34.9	19.1	38.1	22.2	41.3
Over 2743		19.1	38.1	22.2	41.3	25.4	44.3
1524 mm and under		12.7	44.5	15.9	47.6	19.1	47.6
Over 1524 to 2134, incl	over 15240	15.9	44.5	19.1	47.6	22.2	47.6
Over 2134 to 2743, incl		15.9	44.5	19.1	47.6	22.2	47.6
Over 2743		22.2	44.5	25.4	50.8	28.6	57.2

<sup>A</sup> The tolerance under specified width and length is 1/4 in. (6.4 mm).

<sup>B</sup> Rectangular plates over 1 in. (25.4 mm) in thickness are not commonly sheared and are machined or otherwise cut to length and width or produced in the size as rolled, uncropped.

**TABLE 16  
CAMBER TOLERANCE FOR PLATES**

Tolerance =  $\frac{1}{8}$  in. (3.175 mm)  $\times$  [ft (cm) of length/5 ft (152.4 cm)]

**TABLE 17  
DIAMETER TOLERANCE FOR CIRCULAR PLATES**

Specified Diameter, in. (mm)	Tolerance over Specified Diameter for Given Diameter and Thickness (No Under Tolerance), in. (mm)		
	Thickness		
	To $\frac{3}{8}$ (9.5), excl	$\frac{3}{8}$ to $\frac{5}{8}$ (9.5 to 15.9), excl	$\frac{5}{8}$ (15.9) and over
To 60 (1524), excl	$\frac{1}{4}$ (6.4)	$\frac{3}{8}$ (9.5)	$\frac{1}{2}$ (12.7)
60 to 84 (1524 to 2134), excl	$\frac{5}{16}$ (7.9)	$\frac{7}{16}$ (11.1)	$\frac{9}{16}$ (14.3)
84 to 108 (2134 to 2743), excl	$\frac{3}{8}$ (9.5)	$\frac{1}{2}$ (12.7)	$\frac{5}{8}$ (15.9)
108 to 130 (2743 to 3302), excl	$\frac{7}{16}$ (11.1)	$\frac{9}{16}$ (14.3)	$\frac{11}{16}$ (17.5)

**TABLE 18  
FLATNESS TOLERANCES FOR PLATES**

Specified Thickness, in.	Flatness Tolerance (Deviation from A Flat Horizontal Surface) for Thickness and Width Given, in.								
	Width, in.								
	48 and Under	Over 48 to 60, excl	60 to 72, excl	72 to 84, excl	84 to 96, excl	96 to 108, excl	108 to 120, excl	120 to 144, excl	144 and Over
$\frac{3}{16}$ to $\frac{1}{4}$ , excl	$\frac{3}{4}$	$1\frac{1}{16}$	$1\frac{1}{4}$	$1\frac{1}{8}$	$1\frac{5}{8}$	$1\frac{5}{8}$	$1\frac{7}{8}$	2	...
$\frac{1}{4}$ to $\frac{3}{8}$ , excl	$1\frac{1}{16}$	$\frac{3}{4}$	$1\frac{15}{16}$	$1\frac{1}{8}$	$1\frac{3}{8}$	$1\frac{7}{16}$	$1\frac{9}{16}$	$1\frac{7}{8}$	...
$\frac{3}{8}$ to $\frac{1}{2}$ , excl	$\frac{1}{2}$	$\frac{9}{16}$	$1\frac{11}{16}$	$\frac{3}{4}$	$1\frac{15}{16}$	$1\frac{1}{8}$	$1\frac{1}{4}$	$1\frac{7}{16}$	$1\frac{3}{4}$
$\frac{1}{2}$ to $\frac{3}{4}$ , excl	$\frac{1}{2}$	$\frac{9}{16}$	$\frac{5}{8}$	$\frac{5}{8}$	$1\frac{13}{16}$	$1\frac{1}{8}$	$1\frac{1}{8}$	$1\frac{1}{8}$	$1\frac{3}{8}$
$\frac{3}{4}$ to 1, excl	$\frac{1}{2}$	$\frac{9}{16}$	$\frac{5}{8}$	$\frac{5}{8}$	$\frac{3}{4}$	$1\frac{13}{16}$	$1\frac{15}{16}$	1	$1\frac{1}{8}$
1 to $1\frac{1}{2}$ , excl	$\frac{1}{2}$	$\frac{9}{16}$	$\frac{9}{16}$	$\frac{9}{16}$	$1\frac{11}{16}$	$1\frac{11}{16}$	$1\frac{11}{16}$	$\frac{3}{4}$	1
$1\frac{1}{2}$ to 4, excl	$\frac{3}{16}$	$\frac{5}{16}$	$\frac{3}{8}$	$\frac{7}{16}$	$\frac{1}{2}$	$\frac{9}{16}$	$\frac{5}{8}$	$\frac{3}{4}$	$\frac{7}{8}$
4 to 6, excl	$\frac{1}{4}$	$\frac{3}{8}$	$\frac{1}{2}$	$\frac{9}{16}$	$\frac{5}{8}$	$\frac{3}{4}$	$\frac{7}{8}$	1	$1\frac{1}{8}$

Specified Thickness, mm.	Flatness Tolerance (Deviation from A Flat Horizontal Surface) for Thickness and Width Given, mm								
	Width, mm								
	1219 and Under	Over 1219 to 1524, excl	1524 to 1829, excl	1829 to 2134, excl	2134 to 2438, excl	2438 to 2743, excl	2743 to 3048, excl	3048 to 3658, excl	3658 and Over
4.8 to 6.4, excl	19.0	27.0	31.8	34.9	41.3	41.3	47.6	50.8	...
6.4 to 9.5, excl	17.5	19.0	23.8	28.6	34.9	36.5	39.7	47.6	...
9.5 to 12.7, excl	12.7	14.3	17.5	19.0	23.8	28.6	31.8	36.5	44.5
12.7 to 19.0, excl	12.7	14.3	15.9	15.9	20.6	28.6	28.6	28.6	34.9
19.0 to 25.4, excl	12.7	14.3	15.9	15.9	19.0	20.6	23.8	25.4	28.6
25.4 to 38.1, excl	12.7	14.3	14.3	14.3	17.5	17.5	17.5	19.0	25.4
38.1 to 102, excl	4.8	7.9	9.5	11.1	12.7	14.3	15.9	19.0	22.2
102 to 152, excl	6.4	9.5	12.7	14.3	15.9	19.0	22.2	25.4	28.6

**TABLE 19  
RECOMMENDED PLATE FLAME-CUTTING  
TOLERANCES TO CLEAN UP IN MACHINING**

Specified Thickness, in. (mm)	Machining Allowance per Edge, in. (mm)
Under 2 (51)	$\frac{1}{4}$ (6.4)
Over 2 to 3 (51 to 76), incl	$\frac{3}{8}$ (9.5)
Over 3 to 6 (76 to 152), incl	$\frac{1}{2}$ (12.7)

value or a calculated value shall be rounded off as indicated below, in accordance with the rounding-off method of Practice E 29.

Requirement	Rounded-Off Unit for Observed or Calculated Value
Chemical composition and tolerances (when expressed in decimals)	Nearest unit in the last right-hand place of figures of the specified limit. If two choices are possible, as when the digits dropped are exactly a 5, or a 5 followed only by zeros, choose the one ending in an even digit, with zero defined as an even digit
Tensile strength and yield strength	Nearest 1000 psi (6.9 MPa)
Elongation	Nearest 1%
Grain size: 0.0024 in. (0.060 mm) or larger	Nearest multiple of 0.0002 in. (0.005 mm)
Less than 0.0024 in. (0.060 mm)	Nearest multiple of 0.0001 in. (0.002 mm)

**13. Inspection**

**13.1** Inspection of the material shall be made as agreed upon between the manufacturer and the purchaser as part of the purchase contract.

**14. Rejection and Rehearing**

**14.1** Material that fails to conform to the requirements of this specification may be rejected. Rejection should be

**TABLE 20  
ABRASIVE-CUTTING WIDTH AND LENGTH  
TOLERANCES**

Specified Thickness, in. (mm)	Tolerance Over Specified Width and Length, in. (mm) <sup>4</sup>	
	Width	Length
Up to $1\frac{1}{4}$ (32)	$\frac{1}{8}$ (3.2)	$\frac{1}{8}$ (3.2)
Over $1\frac{1}{4}$ to $2\frac{3}{4}$ (32 to 70)	$\frac{3}{16}$ (4.8)	$\frac{3}{16}$ (4.8)

<sup>4</sup>The tolerance under specified width and length is  $\frac{1}{8}$  in. (3.2 mm).

reported to the producer or supplier promptly and in writing. In case of dissatisfaction with the results of the test, the producer or supplier may make claim for a rehearing.

**15. Certification**

**15.1** When specified in the purchase order or contract, a producer's or supplier's certification shall be furnished to the purchaser that the material was manufactured, sampled, tested, and inspected in accordance with this specification and has been found to meet the requirements. When specified in the purchase order or contract, a report of the test results shall be furnished.

**16. Product Marking**

**16.1** The following information shall be marked on the material: The name of the material or UNS number, heat number, the letters ASTM, the specification number, the year of issue, the size, and other such information as may be defined in the contract or order.

**17. Keywords**

**17.1** N08330; N08332; plate; sheet; strip

## APPENDIX

## (Nonmandatory Information)

**X1. FINISHES**

**X1.1 Scope** — This appendix lists the finishes in which plate, sheet, and strip are normally supplied. These are subject to change and the manufacturer should be consulted for the latest information available.

**X1.2 Sheet** — The various types of finish procurable on sheet products are:

**X1.2.1 No. 1 Finish** — Hot-rolled, annealed, and descaled.

**X1.2.2 No. 2D Finish** — Dull, cold-rolled finish.

**X1.2.3 No. 2B Finish** — Bright, cold-rolled finish.

**X1.2.3.1 Bright-Annealed Finish** — A bright cold-rolled finish retained by final annealing in a controlled atmosphere furnace.

NOTE X1.1 — Explanation of Finish:

*No. 1* — Produced on hand sheet mills by hot rolling to specified thicknesses followed by annealing and descaling. Generally used in industrial applications, such as for heat or corrosion resistance, where smoothness and uniformity of finish is not of particular importance.

*No. 2D* — Produced on either hand sheet mills or continuous mills by cold rolling to the specified thickness, annealing, and descaling. The dull finish may result from the descaling or pickling operation or may be developed by a final light cold-rolled pass on dull rolls. The dull finish is favorable for the retention of lubricants on the surface in deep drawing operations. This finish is generally used in forming deep drawn articles which may be polished after fabrication.

*No. 2B* — Commonly produced the same as No. 2D, except that the annealed and descaled sheet receives a final light cold-rolled pass on polished rolls. This is a general purpose cold-rolled finish. It is commonly used for all but exceptionally difficult deep drawing application. This finish is more readily polished than No. 1 or No. 2D finish.

*Bright-Annealed Finish* — A bright cold-rolled highly reflective finish retained by final annealing in a controlled atmosphere furnace. The purpose of the atmosphere is to prevent scaling or oxidation during annealing. The atmosphere is usually comprised of either dry hydrogen or a mixture of dry hydrogen and dry nitrogen (sometimes known as dissociated ammonia).

**X1.3 Strip** — The various types of finish procurable on cold-rolled strip products shall be as follows:

**X1.3.1 No. 1 Finish** — Cold-rolled to specified thickness, annealed, and pickled.

**X1.3.2 No. 2 Finish** — Same as No. 1 finish, followed by a final light cold-rolled pass, generally on highly-polished rolls.

**X1.3.3 Bright-Annealed Finish** — A bright cold-rolled finish retained by final annealing in a controlled atmosphere furnace.

NOTE X1.2 — Explanation of Finish:

*No. 1* — Appearance may be dull-gray matte to fairly reflective. This finish is used for severely drawn or formed parts as well as for applications where the brighter No. 2 finish is not required, such as in parts for heat resistance.

*No. 2* — This finish has a smoother and more reflective surface. This is a general purpose finish, widely used for household and automotive trim, tableware, utensils, trays, etc.

*Bright-Annealed Finish* — A bright cold-rolled highly reflective finish retained by final annealing in a controlled atmosphere furnace. The purpose of the atmosphere is to prevent scaling or oxidation during annealing. The atmosphere is usually comprised of either dry hydrogen or a mixture of dry hydrogen and dry nitrogen (sometimes known as dissociated ammonia).

**X1.3.4** The various types of edges obtainable on strip are as follows:

**X1.3.5 No. 1 Edge** — Rolled edge, either round or square as specified.

**X1.3.6 No. 3 Edge** — An edge produced by slitting.

**X1.3.7 No. 5 Edge** — Approximately square edge produced by rolling or filing after slitting.

**X1.4 Plate** — The types of finish obtainable on plate are as follows:

**X1.4.1 Hot-Rolled, Annealed** — Scale not removed. Use of plates in this condition is generally confined to heat-resisting applications.

**X1.4.2 Hot-Rolled, Annealed, Descaled** — Scale removed by a blast-cleaning or pickling operation. Finish commonly preferred for corrosion resisting applications or where non-flux type welding operations will be performed.

**X1.4.3 Cold-Rolled, Annealed** — Bright-annealed finish or scale removed by a blast-cleaning or pickling operation.

ASMENORMDOC.COM : Click to view the full PDF of ASME BPVC.II.B (ASME BPVC Section II part B) 2025

INTENTIONALLY LEFT BLANK

## SPECIFICATION FOR WELDED COPPER AND COPPER-ALLOY HEAT EXCHANGER TUBE



**SB-543/SB-543M**

(Identical with ASTM Specification B543/B543M-18 except that certification and test reports have been made mandatory.)

ASMENORMDOC.COM : Click to view the full PDF of ASME BPVC.II.B (ASME BPVC Section II part B) 2025

# Specification for Welded Copper and Copper-Alloy Heat Exchanger Tube

## 1. Scope

1.1 This specification establishes the requirements for welded tube of copper and various copper alloys up to 3 1/8 in., inclusive, in diameter, for use in surface condensers, evaporators, heat exchangers, and general engineering applications. The following coppers or copper alloys are involved:

Copper or Copper Alloy UNS No.	Previously Used Designation	Type of Metal
C10800 <sup>A</sup>	...	oxygen-free, low phosphorus
C12200 <sup>A</sup>	...	DHP phosphorized, high residual phosphorus
C19400	...	copper-iron alloy
C23000	...	red brass
C44300	...	arsenical admiralty
C44400	...	antimonial admiralty
C44500	...	phosphorized admiralty
C68700	...	arsenical aluminum brass
C70400	...	95-5 copper-nickel
C70600	...	90-10 copper-nickel
C70620	...	90-10 copper-nickel (Modified for Welding)
C71000	...	80-20 copper-nickel
C71500	...	70-30 copper-nickel
C71520	...	70-30 copper-nickel (Modified for Welding)
C71640	...	copper-nickel-iron-manganese
C72200	...	...

<sup>A</sup> Copper UNS Nos. C10800 and C12200 are classified in Classification B224.

1.2 The values stated in either inch-pound or SI units are to be regarded separately as standard. Within the text, SI units are shown in brackets. The values stated in each system may not be exact equivalents; therefore, each system shall be used independently of the other. Combining values from the two systems may result in non-conformance with the standard.

1.3 *This standard does not purport to address all of the safety concerns, if any, associated with its use. It is the responsibility of the user of this standard to establish appropriate safety, health, and environmental practices and deter-*

*mine the applicability of regulatory limitations prior to use.* (Warning—Mercury has been designated by many regulatory agencies as a hazardous substance that can cause serious medical issues. Mercury, or its vapor, has been demonstrated to be hazardous to health and corrosive to materials. Use caution when handling mercury and mercury-containing products. See the applicable product Safety Data Sheet (SDS) for additional information. The potential exists that selling mercury or mercury-containing products, or both, is prohibited by local or national law. Users must determine legality of sales in their location.)

1.4 *This international standard was developed in accordance with internationally recognized principles on standardization established in the Decision on Principles for the Development of International Standards, Guides and Recommendations issued by the World Trade Organization Technical Barriers to Trade (TBT) Committee.*

## 2. Referenced Documents

### 2.1 ASTM Standards:

- B153 Test Method for Expansion (Pin Test) of Copper and Copper-Alloy Pipe and Tubing
- B154 Test Method for Mercurous Nitrate Test for Copper Alloys
- B224 Classification of Coppers
- B846 Terminology for Copper and Copper Alloys
- B858 Test Method for Ammonia Vapor Test for Determining Susceptibility to Stress Corrosion Cracking in Copper Alloys
- B900 Practice for Packaging of Copper and Copper Alloy Mill Products for U.S. Government Agencies
- B968/B968M Test Method for Flattening of Copper and Copper-Alloy Pipe and Tube
- E3 Guide for Preparation of Metallographic Specimens
- E8/E8M Test Methods for Tension Testing of Metallic Materials
- E29 Practice for Using Significant Digits in Test Data to Determine Conformance with Specifications
- E53 Test Method for Determination of Copper in Unalloyed

#### Copper by Gravimetry

- E54 Test Methods for Chemical Analysis of Special Brasses and Bronzes (Withdrawn 2002)
- E62 Test Methods for Chemical Analysis of Copper and Copper Alloys (Photometric Methods) (Withdrawn 2010)
- E112 Test Methods for Determining Average Grain Size
- E118 Test Methods for Chemical Analysis of Copper-Chromium Alloys (Withdrawn 2010)
- E243 Practice for Electromagnetic (Eddy Current) Examination of Copper and Copper-Alloy Tubes
- E255 Practice for Sampling Copper and Copper Alloys for the Determination of Chemical Composition
- E478 Test Methods for Chemical Analysis of Copper Alloys
- E527 Practice for Numbering Metals and Alloys in the Unified Numbering System (UNS)

#### 2.2 ASME Standard:

ASME Boiler and Pressure Vessel Code

### 3. Terminology

3.1 For the definitions of the terms related to copper and copper alloys, refer to Terminology B846.

### 4. Types of Welded Tube

4.1 *Forge-Welded Tube* manufactured as described in 6.2.2.1, 6.2.2.2, and 6.2.2.3.

4.1.1 *As-Welded Tube*—Forge-welded tube with internal and external flash removed and no further refinement of grain structure.

4.1.2 *Welded and Annealed Tube*—Forge-welded tube with internal and external flash removed, that has been annealed to produce a uniform grain size appropriate to the specified annealed temper.

4.1.3 *Welded and Cold-Reduced Tube*—Forge-welded tube with internal and external flash removed and subsequently cold-reduced to conform to the specified size and temper.

4.1.4 *Welded and Cold-Drawn Tube*—Forge-welded tube with internal and external flash removed and subsequently cold-drawn over a plug or mandrel to the specified size and temper.

4.2 *Fusion-Welded Tube* manufactured as described in section 6.3.

4.2.1 *As-Welded Tube*—Fusion-welded tube with no further refinement of grain structure.

4.2.2 *Welded and Annealed Tube*—Fusion-welded tube that has been annealed to produce a uniform grain size appropriate to the specified annealed temper. The structure of the weld zone shall be that which is typical of a fusion weld.

4.2.3 *Welded and Cold-Reduced Tube*—Fusion-welded tube subsequently cold-reduced to conform to the specified size and temper.

4.2.4 *Welded and Cold-Drawn Tube*—Fusion-welded tube subsequently cold-drawn over a plug or mandrel to the specified size and temper.

4.3 *Fully Finished Tube*—Welded tube with internal and external flash removed, if present, and subsequently cold-drawn over a plug or mandrel and annealed, and redrawn when necessary to conform to the specified temper.

### 5. Ordering Information

5.1 Include the following information when placing orders for product under this specification, as applicable:

5.1.1 ASTM designation and year of issue;

5.1.2 Copper or Copper Alloy UNS No. designation (for example, UNS No. C10800);

5.1.3 Tube type (Section 4);

5.1.4 Temper (Section 8);

5.1.5 Dimensions, the diameter, wall thickness, whether minimum or nominal wall, and length (Section 14); and

5.1.6 Quantity of each size (number of pieces and length, in inches or feet and inches);

5.2 The following options are available but may not be included unless specified at the time of placing of the order, when required:

5.2.1 When heat identification or traceability details;

5.2.2 Whether a pressure test is to be used instead of the eddy-current test (Section 13.1);

5.2.3 Whether cut ends of the tube are to be deburred, chamfered, or otherwise treated (Section 15);

5.2.4 If the product is to be subsequently welded, (see Table 1, Footnote F);

5.2.5 DELETED

5.2.6 DELETED

5.3 If product is purchased for agencies of the U.S. Government (see the Supplementary Requirements section of {this specification or the general requirements section} for additional requirements, if specified), and

5.3.1 DELETED

### 6. Materials and Manufacture

#### 6.1 Materials:

6.1.1 The material of manufacture shall be strip of one of the Copper Alloy UNS Nos. listed in section 1.1 of such purity and soundness as to be suitable for processing into the products prescribed herein.

6.1.2 When specified in the contract or purchase order that heat identification or traceability is required, the purchaser shall specify the details desired.

#### 6.2 Manufacture:

6.2.1 The product shall be manufactured by forming the material into a tubular shape on a suitable forming mill.

6.2.2 Welding shall be accomplished by any process that produces a forge weld leaving no crevice in the weld seam visible to the unaided eye.

6.2.2.1 *Forge-Welded Tube*—The edges of the strip shall be heated to the required welding temperature, usually by high frequency electric current, and be pressed firmly together causing a forge-type joint to be formed with internal and external flash or bead.

6.2.2.2 The external flash (that portion of the weld which extends beyond the normal wall) shall always be removed.

TABLE 1 Chemical Requirements

Copper or Copper Alloy UNS No.	Composition, %											
	Copper <sup>A</sup>	Nickel incl Cobalt	Lead, max	Iron	Zinc	Man-ganese	Aluminum	Phosphorus	Tin	Antimony	Arsenic	Other Elements
C10800	99.95 <sup>A, B</sup> min	...	...	...	...	...	...	0.005–0.012	...	...	...	...
C12200	99.9 <sup>A</sup> min	...	...	...	...	...	...	0.015–0.040	...	...	...	...
C19400	97.0 min	...	0.03	2.1–2.6	0.05–0.20	...	...	0.015–0.15	...	...	...	...
C23000	84.0–86.0 <sup>C, D</sup>	...	0.05	0.05 max	remainder	...	...	...	...	...	...	...
C44300	70.0–73.0	...	0.07	0.06 max	remainder	...	...	...	0.8–1.2 <sup>E</sup>	...	0.02–0.06	...
C44400	70.0–73.0	...	0.07	0.06 max	remainder	...	...	...	0.8–1.2 <sup>E</sup>	0.02–0.10	...	...
C44500	70.0–73.0	...	0.07	0.06 max	remainder	...	...	0.02–0.10	0.8–1.2 <sup>E</sup>	...	...	...
C68700	76.0–79.0 <sup>A, F</sup>	...	0.07	0.06 max	remainder	...	1.8–2.5	...	...	...	0.02–0.06	...
C70400	remainder <sup>A, F</sup>	4.8–6.2	0.05	1.3–1.7	1.0 max	0.30–0.8	...	...	...	...	...	...
C70600	remainder <sup>A, F</sup>	9.0–11.0	0.05	1.0–1.8	1.0 max	1.0 max	...	...	...	...	...	...
C70620	86.5 min <sup>A, F</sup>	9.0–11.0	0.02	1.0–1.8	0.50 max	1.0	...	0.02 max	...	...	...	C 0.05 max S 0.02 max
C71000	remainder <sup>A, F, G</sup>	19.0–23.0	0.05	0.50–1.0	1.0 max <sup>G</sup>	1.0 max	...	<sup>G</sup>	...	...	...	<sup>G</sup>
C71500	remainder <sup>A, F</sup>	29.0–33.0	0.05	0.40–1.0	1.0 max	1.0 max	...	...	...	...	...	...
C71520	65.0 min <sup>A, F</sup>	29.0–33.0	0.02	0.40–1.0	0.50 max	1.0 max	...	0.02 max	...	...	...	C 0.05 max S 0.02 max
C71640	remainder <sup>A, F, G</sup>	29.0–32.0	0.05 <sup>G</sup>	1.7–2.3	1.0 max <sup>G</sup>	1.5–2.5	...	<sup>G</sup>	...	...	...	C 0.06 <sup>G</sup> max S 0.03 max
C72200	remainder <sup>A, C, G, H</sup>	15.0–18.0	0.05 <sup>G</sup>	0.50–1.0	1.0 max <sup>G</sup>	1.0 max	...	<sup>G</sup>	...	...	...	<sup>G</sup> Si 0.03 max Ti 0.03 max <sup>H</sup>

<sup>A</sup> Cu value includes Ag.  
<sup>B</sup> Copper + silver + phosphorus.  
<sup>C</sup> Cu + Sum of Named Elements, 99.8 % min.  
<sup>D</sup> Not including Ag.  
<sup>E</sup> For tubular products, the minimum Sn content may be 0.9 %  
<sup>F</sup> Cu + Sum of Named Elements, 99.5 % min.  
<sup>G</sup> When the product is for subsequent welding applications and so specified by the purchaser, zinc shall be 0.50 % max, lead 0.02 % max, phosphorus 0.02 % max, sulfur 0.02 % max, and carbon 0.05 % max.  
<sup>H</sup> Chromium 0.30 to 0.7.

6.2.2.3 The internal flash shall be removed to the extent that it shall not exceed 0.006 in. [0.152 mm] in height or 10 % of the nominal wall thickness, whichever is greater.

6.3 *Fusion-Welded Tube*—The edges of the strip shall be brought together and welded, usually by a GTAW welding process, without the addition of filler metal, causing a fusion-type joint to be formed with no internal or external flash or bead removal necessary.

6.4 *Fully Finished Tube*—May be welded and subsequently processed by any method that would produce a tube suitable for subsequent cold-drawing and annealing.

6.5 There shall be no crevice in the weld seam visible to the unaided eye.

**7. Chemical Composition**

7.1 The material shall conform to the chemical compositional requirements in Table 1 for the Copper or Copper Alloy UNS No. designation specified in the ordering information.

7.2 The composition limits do not preclude the presence of other elements. By agreement between the manufacturer and purchaser, limits may be established and analysis required for unnamed elements.

7.3 For copper alloys in which copper is specified as the remainder, copper may be taken as the difference between the sum of all the elements analyzed and 100 %.

7.3.1 *Copper Alloy UNS Nos. C70400, C70600, C70620, C71000, C71500, and C71640*—When all the elements in Table 1 are analyzed, their sum shall be 99.5 % minimum.

7.3.2 *Copper Alloy UNS No. C72200*—When all the elements in Table 1 are analyzed, their sum shall be 99.8 % minimum.

7.4 For copper alloys in which zinc is specified as the remainder, either copper or zinc may be taken as the difference between the sum of all the elements analyzed and 100 %.

7.4.1 *Copper Alloy UNS No. C23000*—When all the elements in Table 1 are analyzed, their sum shall be 99.8 % minimum.

7.4.2 *Copper Alloy UNS Nos. C44300, C44400, and C44500*—When all the elements in Table 1 are analyzed, their sum shall be 99.6 % minimum.

7.4.3 *Copper Alloy UNS No. C68700*—When all the elements in Table 1 are analyzed, their sum shall be 99.5 % minimum.

**8. Temper**

8.1 Tube tempers shall be designated as follows:

- 8.1.1 Welded and annealed WO61.
- 8.1.1.1 Welded and light cold worked WC55.

8.2 Other tempers shall be produced to the mechanical properties as agreed upon between the manufacturer or supplier and the purchaser.

8.3 Tubes of Copper Alloy UNS Nos. C23000, C44300, C44400, C44500, and C68700 shall be furnished in the annealed temper or the stress-relieved condition as specified in the purchase order unless otherwise agreed upon between the purchaser and the manufacturer or supplier.

8.4 Tubes of Copper Alloy UNS Nos. C12200, C19400, C70400, C70600, C70620, C71000, C71500, C71520, C71640, and C72200 are normally supplied in the temper specified in the purchase order without stress-relief treatment.

NOTE 1—Some tubes, when subjected to aggressive environments, may be subject to stress-corrosion cracking failure because of the residual tensile stresses developed in straightening. For such applications, it is suggested that tubes of Copper Alloy UNS Nos. C23000, C44300, C44400, C44500, and C68700 be subjected to a stress-relieving thermal treatment subsequent to straightening. If required, this must be specified on the purchase order or contract. Tolerances for roundness and length, and the condition of straightness, for tube so ordered, shall be to the requirements agreed upon between the manufacturer and the purchaser.

## 9. Grain Size for Annealed Tempers

9.1 Samples of annealed temper tubes shall be examined at a magnification of 75 diameters. The grain size shall be determined in the wall beneath the internal enhancement. While there is not grain size range, the microstructure shall show complete recrystallization and the weld zone shall have a structure typical of hot-forged welds.

## 10. Mechanical Property Requirements

### 10.1 Tensile Strength and Yield Strength Requirements:

10.2 Product furnished under this specification shall conform to the tensile and yield strength requirements prescribed in Table 2 or Table 3 when tested in accordance with Test Methods E8/E8M.

10.2.1 Acceptance or rejection based upon mechanical properties shall depend only on tensile strength and yield strength.

## 11. Performance Requirements

### 11.1 Expansion Test Requirements:

11.1.1 Product in the annealed tempers and the light cold-worked temper shall withstand expansion in accordance with Test Method B153 to the degree specified in Table 4.

11.1.2 The expanded tube area shall be free of defects, but blemishes of a nature that do not interfere with the intended application are acceptable.

### 11.2 Flattening Test:

11.2.1 The flattening test shall be performed in accordance with the Test Method section in B968/B968M.

### 11.3 Reverse Bend Test:

11.3.1 When specified in the contract or purchase order, the reverse bend test described in 19.2.8 of the Test Methods section shall be performed.

11.3.2 The sample shall be free of defects, but blemishes of a nature that do not interfere with the intended application are acceptable.

## 12. Other Requirements

### 12.1 Mercurous Nitrate Test or Ammonia Vapor Test:

12.1.1 The mercurous nitrate or ammonia vapor test is required only for Copper Alloys UNS Nos. C23000; C44300;

TABLE 2 Tensile Requirements—Inch-Pound Values

NOTE 1—See Table 3 for tensile requirements—SI values.

Copper or Copper Alloy UNS No.	Temper		Tensile Strength, min, ksi <sup>A</sup>	Yield Strength at 0.5 % Extension Under Load, min, ksi <sup>A</sup>
	Designation	Name		
C10800, C12200	W061	annealed	30	9 <sup>B</sup>
	WC55	light cold-worked	32	15
C19400	W061	annealed	45	15
	WC55	light cold-worked	45	22
C23000	W061	annealed	40	12
	WC55	light cold-worked	42	20
C44300, C44400, C44500	W061	annealed	45	15
	WC55	light cold-worked	50	35
	W061	annealed	50	18
C68700	WC55	light cold-worked	c	c
	W061	annealed	38	12
C70400	WC55	light cold-worked	40	30
	W061	annealed	40	15
C70600	WC55	light cold-worked	45	35
	W061	annealed	40	15
C70620	WC55	light cold-worked	45	35
	W061	annealed	45	16
C71000	WC55	light cold-worked	50	35
	W061	annealed	52	18
C71500	WC55	light cold-worked	54	35
	W061	annealed	52	18
C71520	WC55	light cold-worked	54	35
	W061	annealed	63	25
C71640	WC55	light cold-worked	75	40
	W061	annealed	45	16
C72200	WC55	light cold-worked	50	30

<sup>A</sup> ksi = 1000 psi.

<sup>B</sup> Light straightening operation is permitted.

<sup>C</sup> Where no properties are shown, strength requirements shall be as agreed upon between the purchaser and the manufacturer or supplier.

TABLE 3 Tensile Requirements—SI Values

NOTE 1—See Table 2 for tensile requirements—inch-pound values.

Copper or Copper Alloy UNS No.	Temper		Tensile Strength, min, MPA	Yield Strength at 0.5 % Extension Under Load, min, MPA
	Designation	Name		
C10800, C12200	W061	annealed	205	60 <sup>A</sup>
	WC55	light cold-worked	220	105
C19400	W061	annealed	310	105
	WC55	light cold-worked	310	150
C23000	W061	annealed	275	85
	WC55	light cold-worked	290	140
C44300, C44400, C44500	W061	annealed	310	105
	WC55	light cold-worked	345	240
C68700	W061	annealed	345	125
	WC55	light cold-worked	<sup>B</sup>	<sup>B</sup>
C70400	W061	annealed	260	85
	WC55	light cold-worked	275	205
C70600	W061	annealed	275	105
	WC55	light cold-worked	310	240
C70620	W061	annealed	275	105
	WC55	light cold-worked	310	240
C71000	W061	annealed	310	110
	WC55	light cold-worked	345	240
C71500	W061	annealed	360	125
	WC55	light cold-worked	370	240
C71520	W061	annealed	360	125
	WC55	light cold-worked	370	240
C71640	W061	annealed	435	170
	WC55	light cold-worked	515	275
C72200	W061	annealed	310	110
	WC55	light cold-worked	345	205

<sup>A</sup> Light straightening operation is permitted.

<sup>B</sup> Where no properties are shown, strength requirements shall be as agreed upon between the purchaser and the manufacturer or supplier.

TABLE 4 Expansion Requirements

Temper	Copper or Copper Alloy UNS No.	Expansion of Tube Outside Diameter, in Percent of Original Outside Diameter	
Annealed	C10800	30	
	C12200	30	
	C19400	20	
	C23000	20	
	C44300, C44400, C44500	20	
	C68700	20	
	C70400	30	
	C70600	30	
	C70620	30	
	C71000	30	
	C71500	30	
	C71520	30	
	C71640	30	
	C72200	30	
	Light cold-worked	C10800	20
		C12200	20
C19400		20	
C70400		20	
C70600		20	
C70620		20	
C71000		20	
C71500		20	
C71520		20	
C71640		20	
C72200		20	
Annealed and light cold- worked, stress relieved	C23000	20	
	C44300, C44400, C44500	20	
	C68700	20	

C4400; C44500; C60800; and C68700; when purchased if not supplied in an annealed temper (**Warning**—Mercury is a definite health hazard. With the Mercurous Nitrate Test, equipment for the detection and removal of mercury vapor produced in volatilization, and the use of protective gloves is recommended.)

12.1.2 The test specimens, cut 6 in. [152 mm] in length from the enhanced section shall withstand, without cracking, an immersion in the standard mercurous nitrate solution in Test Method B154 or immersion in the ammonia vapor solution as defined in Test Method B858.

12.1.3 Unless otherwise agreed upon between the manufacturer or supplier and the purchaser, the manufacturer shall have the option of using either the mercurous nitrate test or the ammonia vapor test. If agreement cannot be reached, the mercurous nitrate test standard shall be utilized.

12.1.4 If the ammonia vapor test is selected, the appropriate risk level pH value for the test solution shall be agreed upon by the manufacturer and purchaser, or alternately, if the purchaser defers to the manufacturer’s expertise for the selection of the test pH value, the minimum value selected shall be 9.8.

13. Nondestructive Testing

13.1 Each tube shall be subjected to the eddy-current test in 13.1.1. Fully finished tube (see 4.3) may be tested in the final drawn, annealed, or heat-treatment temper or in the drawn temper prior to the final anneal or heat treatment, unless otherwise agreed upon between the manufacturer or supplier and the purchaser. Tube supplied welded and annealed (see 4.1.2) may be tested in the welded condition before anneal or

heat treatment, unless otherwise agreed upon between the manufacturer or supplier and the purchaser. The purchaser may specify either of the tests in 13.1.2 or 13.1.3 as an alternative to the eddy-current test.

13.1.1 *Eddy Current Test*—Each tube shall be passed through an eddy-current testing unit adjusted to provide information on the suitability of the tube for the intended application. Testing shall follow the procedures of Practice E243, except as modified in 13.1.1.2.

13.1.1.1 The depth of the round-bottom transverse notches and the diameters of the drilled holes in the calibrating tube used to adjust the sensitivity of the test unit are shown in Table 5 or Table 6 and Table 7 or Table 8 respectively.

13.1.1.2 The discontinuities used to calibrate the test system may be placed in the strip from which the tube will be manufactured. These calibration discontinuities will pass through the continuous operations of forming, welding, and eddy-current testing. The test unit sensitivity required to detect the resultant discontinuities shall be equivalent to or greater than that required to detect the notches or drilled holes of Table 5 or Table 6 and Table 7 or Table 8 respectively, or other calibration discontinuities that may be used by mutual agreement between the manufacturer or supplier and the purchaser. Calibration discontinuities may be on the outside tube surface, the internal tube surface, or through the tube wall and shall be spaced to provide signal resolution adequate for interpretation. Each calibration discontinuity shall be detected by the eddy-current tester.

13.1.1.3 Tubes that do not actuate the signaling device of the eddy-current tester shall be considered as conforming to the requirements of this test. Tubes causing irrelevant signals because of moisture, soil, and like effects may be reconditioned and retested. Such tubes, when retested to the original test parameters, shall be considered to conform if they do not cause output signals beyond the acceptable limits. Tubes causing irrelevant signals because of visible and identifiable handling marks may be retested by the hydrostatic test prescribed in 13.1.2, or the pneumatic test prescribed in 13.1.3. Tubes meeting requirements of either test shall be considered to conform if the tube dimensions are within the prescribed limits, unless otherwise agreed to by the manufacturer or supplier and the purchaser.

13.1.2 *Hydrostatic Test*—When specified, each tube selected in accordance with 13.1 shall withstand, without showing evidence of leakage, an internal hydrostatic pressure sufficient to subject the material to a fiber stress of 7000 psi [48 MPa], determined by the following equation for thin hollow cylinders

**TABLE 5 Notch Depth—Inch-Pound Values**

NOTE 1—See Table 6 for notch depth—SI values.

Tube Wall Thickness, in.	Tube Outside Diameter, in.		
	Over ¼ to ¾, incl	Over ¾ to 1¼, incl	Over 1¼ to 3⅞, incl
Over 0.017–0.032	0.005	0.006	0.007
Incl 0.032–0.049	0.006	0.006	0.0075
Incl 0.049–0.083	0.007	0.0075	0.008
Incl 0.083–0.109	0.0075	0.0085	0.0095
Incl 0.109–0.120	0.009	0.009	0.011

**TABLE 6 Notch Depth—SI Values**

NOTE 1—See Table 5 for notch depth—inch-pound values.

Tube Wall Thickness, mm	Tube Outside Diameter, mm		
	Over 6 to 19, incl	Over 19 to 32, incl	Over 32 to 80, incl
Over 0.4–0.8	0.13	0.15	0.18
Incl 0.8–1.3	0.15	0.15	0.19
Incl 1.3–2.1	0.18	0.19	0.20
Incl 2.1–2.8	0.19	0.22	0.24
Incl 2.8–3.0	0.23	0.23	0.28

**TABLE 7 Diameter of Drilled Holes—Inch-Pound Values**

NOTE 1—See Table 8 for diameter of drilled holes—SI values.

Tube Outside Diameter	Diameter of Drilled Holes	Drill No.
in.	in.	
¼ –¾, incl	0.025	72
Over ¾ –1, incl	0.031	68
Over 1 –1¼, incl	0.036	64
Over 1¼ –1½, incl	0.042	58
Over 1½ –1¾, incl	0.046	56
Over 1¾ –2, incl	0.052	55

**TABLE 8 Diameter of Drilled Holes—SI Values**

NOTE 1—See Table 7 for diameter of drilled holes—inch-pound values.

Tube Outside Diameter	Diameter of Drilled Holes	Drill No.
mm	mm	
6.0–19.0, incl	0.65	72
Over 19.0–25.4, incl	0.80	68
Over 25.4–31.8, incl	0.92	64
Over 31.8–38.1, incl	1.1	58
Over 38.1–44.4, incl	1.2	56
Over 44.4–50.8, incl	1.3	55

under tension. The tube need not be tested at a hydrostatic pressure over 1000 psig [7.0 MPa] unless so specified.

$$P = 2St/(D - 0.8t) \quad (1)$$

where:

- $P$  = hydrostatic pressure, psig [MPa],
- $t$  = thickness of tube wall, in. [mm],
- $D$  = outside diameter of the tube, in. [mm], and
- $S$  = allowable stress of the material, psi [MPa].

13.1.3 *Pneumatic Test*—When specified, each tube shall be subjected to an internal air pressure of 60 psig [400 kPa] minimum for 5 s without showing evidence of leakage. The test method used shall permit easy visual detection of any leakage, such as by having the tube under water or by the pressure-differential method. Any evidence of leakage shall be cause for rejection.

#### 14. Dimensions, Mass, and Permissible Variations

14.1 *Diameter*—The outside diameter of the tubes shall not vary from that specified by more than the amounts shown in Table 9 or Table 10 as measured by “go” and “no-go” ring gages. Where no values are shown in the table, dimensions shall be as agreed upon between the purchaser and the manufacturer or supplier.

**TABLE 9 Diameter Tolerances—Inch-Pound Values**

NOTE 1—See Table 10 for diameter tolerances—SI values.

Outside Diameter, in.	Wall Thickness, in.				
	0.020 <sup>A</sup> 0.022 0.025 0.028	0.032	0.035	0.042	0.049 and Over
	Diameter Tolerance, Plus and Minus, in.				
Up to 0.500, incl	0.003	0.0025	0.0025	0.0025	0.0025
Over 0.500–0.740, incl	0.004	0.004	0.004	0.0035	0.003
Over 0.740–1.000, incl	0.006	0.006	0.005	0.0045	0.004
Over 1.000–1.250, incl	...	0.009	0.008	0.006	0.0045
Over 1.250–1.375, incl	...	...	...	0.008	0.005
Over 1.375–2.000, incl	...	...	...	...	0.006
Over 2.000–3.125, incl	...	...	...	...	0.0065

<sup>A</sup> Thin wall thicknesses are supplied only in light cold-worked tubes.

**TABLE 10 Diameter Tolerances—SI Values**

NOTE 1—See Table 9 for diameter tolerances—inch-pound values.

Outside Diameter, mm	Wall Thickness, mm				
	0.508 <sup>A</sup> 0.559 0.635 0.711	0.813	0.889	1.07	1.24 and Over
	Diameter Tolerance, Plus and Minus, mm				
Up to 12, incl	0.076	0.064	0.064	0.064	0.064
Over 12–18, incl	0.10	0.10	0.10	0.089	0.076
Over 18–25, incl	0.15	0.15	0.13	0.11	0.10
Over 25–35, incl	...	...	...	0.20	0.13
Over 35–50, incl	...	...	...	...	0.15
Over 50–79	...	...	...	...	0.17

<sup>A</sup> Thin wall thicknesses are supplied only in light cold-worked tubes.

14.2 Wall Thickness Tolerances:

14.2.1 Tubes Ordered to Minimum Wall—No tube at its thinnest point shall be less than the specified wall thickness or greater than the specified wall thickness plus twice the tolerance values shown in Table 11 or Table 12.

14.2.2 Tubes Ordered to Nominal Wall—The maximum plus and minus deviation from the nominal wall at any point shall not exceed the values shown in Table 11 or Table 12.

14.3 Length—The length of the tubes shall not be less than that specified when measured at a temperature of 20 °C, but may exceed the specified value by the amounts given in Table 13 or Table 14.

14.4 Squareness of Cut—The departure from squareness of the end of any tube shall not exceed the values shown in Table 15 or Table 16.

NOTE 2—For the purpose of determining conformance with the dimensional requirements prescribed in this specification, any measured value outside the specified limiting values for any dimension may be cause for rejection.

**15. Workmanship, Finish, and Appearance**

15.1 Roundness, straightness, uniformity of the wall thickness, and inner and outer surface of the tube shall be such as to make it suitable for the intended application. Unless

**TABLE 11 Wall Thickness Tolerances—Inch-Pound Values**

NOTE 1—See Table 12 for SI values.

Wall Thickness, in.	Outside Diameter, in.			
	Over 1/8 to 5/8, incl	Over 5/8 to 1, incl	Over 1 to 2, incl	Over 2 to 3.125, incl
	Wall Thickness Tolerances, Plus and Minus, in.			
0.020 incl, to 0.032	0.003	0.003	...	...
0.032 incl, to 0.035	0.003	0.003	0.004	...
0.035 incl, to 0.058	0.004	0.0045	0.0045	0.005
0.058 incl, to 0.083	0.0045	0.005	0.005	0.0055
0.083 incl, to 0.120	0.005	0.0065	0.0065	0.0065
0.120 incl, to 0.135	0.007	0.007	0.0075	0.008

**TABLE 12 Wall Thickness Tolerances, Plus and Minus—SI Values**

NOTE 1—See Table 11 for inch-pound values.

Wall Thickness, mm	Outside Diameter, mm		
	Over 12 to 25, incl	Over 25 to 50, incl	Over 50 to 80, incl
0.50, incl to 0.80	0.08	...	...
0.80, incl to 0.90	0.08	0.10	...
0.90, incl to 1.5	0.11	0.11	0.13
1.5, incl to 2.1	0.13	0.13	0.14
2.1, incl to 3.0	0.17	0.17	0.17
3.0, incl to 3.4	0.18	0.19	0.20

**TABLE 13 Length Tolerances—Inch-Pound Values**

NOTE 1—See Table 14 for SI values.

Specified length, ft	Tolerance, all Plus, in.
Up to 15	$\frac{3}{32}$
Over 15–20, incl	$\frac{1}{8}$
Over 20–30, incl	$\frac{5}{32}$
Over 30–60, incl	$\frac{3}{8}$
Over 60–100, incl <sup>A</sup>	$\frac{1}{2}$

<sup>A</sup> Condenser tubes in lengths over 100 ft are not in present demand. Tolerance values for these lengths will be developed as experience dictates. Tolerance values for lengths in wall thicknesses of 0.020, incl to 0.032 shall be agreed upon between the manufacturer or supplier and the purchaser.

**TABLE 14 Length Tolerances—SI Values**

NOTE 1—See Table 13 for inch-pound values.

Specified Length, mm	Tolerance, all Plus, mm
Up to 4500	2.4
Over 4500–6000, incl	3.2
Over 6000–10 000, incl	4.0
Over 10 000–18 000, incl	9.5
Over 18 000–30 000, incl <sup>A</sup>	13.0

<sup>A</sup> Condenser tubes in lengths over 30 000 mm are not in present demand. Tolerance values for these lengths will be developed as experience dictates. Tolerance values for lengths in wall thicknesses of 0.5, inclusive to 0.8 shall be agreed upon between the manufacturer or supplier and the purchaser.

**TABLE 15 Squareness of Cut—Inch-Pound Values**

NOTE 1—See Table 16 for SI values.

Tube Outside Diameter, in.	Tolerance, in.
Up to $\frac{5}{8}$ , incl	0.010 in.
Over $\frac{5}{8}$	0.016 in./in. of diameter

**TABLE 16 Squareness of Cut—SI Values**

NOTE 1—See Table 15 for inch-pound values.

Tube Outside Diameter, mm	Tolerance, mm
Up to 16, incl	0.25 mm
Over 16	0.40 mm/mm of diameter

otherwise specified on the purchase order, the cut ends of the tubes shall be deburred by use of a rotating wire wheel or other suitable tool.

15.2 Welded and annealed, fully finished annealed, or stress-relieved tubes shall be clean and smooth but may have a superficial, dull iridescent film on both the inside and the

outside surfaces. All other tubes shall be clean and smooth but may have a superficial film of drawing or other lubricant on the surfaces.

## 16. Sampling

16.1 *Sampling*—The lot size, portion size, and selection of sample pieces shall be as follows:

16.1.1 *Lot Size*—600 tubes or 10 000 lb [4550 kg] or a fraction of either, whichever constitutes the greater weight.

16.1.2 *Portion Size*—Sample pieces from two individual lengths of finished product.

16.2 Samples taken for the purpose of the tests prescribed in the specification shall be selected in a manner that will represent correctly the material furnished and avoid needless destruction of finished material when samples representative of the material are available from other sources.

16.3 *Chemical Analysis*—Samples for chemical analysis shall be taken in accordance with Practice E255. Drillings, millings, and so forth, shall be taken in approximately equal weight from each of the sample pieces selected in accordance with 16.1.2 and combined into one composite sample. The minimum weight of the composite sample that is to be divided into three equal parts shall be 150 g.

16.3.1 Instead of sampling in accordance with Practice E255, the manufacturer shall have the option of determining conformance to chemical composition as follows: Conformance shall be determined by the manufacturer by analyzing samples taken at the time the castings are poured or samples taken from the semi-finished product. If the manufacturer determines the chemical composition of the material during the course of manufacture, he shall not be required to sample and analyze the finished product. The number of samples taken for determination of chemical composition shall be as follows:

16.3.1.1 When samples are taken at the time the castings are poured, at least one sample shall be taken for each group of castings poured simultaneously from the same source of molten metal.

16.3.1.2 When samples are taken from the semi-finished product, a sample shall be taken to represent each 10 000 lb [4550 kg] or fraction thereof, except that not more than one sample shall be required per piece.

16.3.2 Due to the discontinuous nature of the processing of castings into wrought products, it is not practical to identify specific casting analysis with a specific quantity of finished material.

16.3.3 In the event that heat identification or traceability is required, the purchaser shall specify the details desired.

## 17. Number of Tests and Retests

### 17.1 Tests:

17.1.1 *Chemical Analysis*—Chemical composition shall determine in accordance with element mean of the results from at least two replicate analyses of the samples, and the results of each replication must meet the requirements of the product specification.

### 17.1.2 Tension Tests:

17.1.2.1 When tensile strength is specified, two tubes shall be selected from each lot and subjected to the tension test which shall, in case of disagreement, be made in accordance with Test Methods E8/E8M.

### 17.1.3 Other Tests:

17.1.3.1 For tests specified in Sections 9; 11; and 12, specimens shall be taken from each of the pieces selected in accordance with 16.1.

### 17.2 Retests:

17.2.1 When requested by the manufacturer or supplier, a retest shall be permitted when results of test obtained by the purchaser fail to conform to the requirements of the product specification.

17.2.2 The retest shall be as directed in the product specification for the initial test, except the number of test specimens shall be twice that normally required for the specified test.

17.2.3 All test specimens shall conform to the product specification requirement(s) in retest. Failure to conform shall be cause for rejection.

## 18. Specimen Preparation

### 18.1 Chemical Analysis:

18.1.1 Preparation of the analytical test specimen shall be the responsibility of the reporting laboratory.

### 18.2 Grain Size:

18.2.1 Test specimen shall be prepared in accordance with Guide E3.

### 18.3 Tensile Test:

18.3.1 The test specimen shall be of the full section of the tube and shall conform to the requirements of the section titled “Specimens for Pipe and Tube” in Test Methods E8/E8M.

18.3.1.1 When the limitations of the testing machine preclude the use of a full section specimen, specimens conforming to “Tension Test Specimens for Large-Diameter Tubular Products” of Test Methods E8/E8M shall be used.

### 18.4 Expansion (Pin Test):

18.4.1 Test specimen shall conform to the requirements of the Specimen Preparation section of Test Method B153.

### 18.5 Flattening Test:

18.5.1 Test specimen shall conform to the appropriate requirements of the Test Specimen Section of Test Method B968/B968M.

### 18.6 Reverse Bend Test:

18.6.1 A representative tube sample shall be cut to a length that will accommodate the test. The sample is permitted to be annealed when the temper is other than annealed.

18.6.2 The product test specimen shall be cut longitudinally, 90° on each side of the weld, when visible or identifiable.

### 18.7 Mercurous Nitrate Test:

18.7.1 Specimens for the mercurous nitrate test shall be 6 in. [152 mm] in length and shall conform to the requirements of Test Method B154.

### 18.8 Ammonia Vapor Test:

18.9 Specimens for the ammonia vapor test shall be 6 in. [152 mm] in length and shall conform to the requirements of Test Method B858.

## 19. Test Methods

19.1 In cases of disagreement, test methods for chemical analysis shall be subject to agreement between the manufacturer or supplier and the purchaser. The following table is a list of published methods, some of which may no longer be viable, which, along with others not listed, may be used subject to agreement.

Element	Method
Copper 99.75 to 99.99	E53 Electrolytic
Copper 60 to 99.74	E478 Electrolytic
Tin 0.9 to 1.2	E478 Titrimetric
Aluminum 1.8 to 6.5	E478 Titrimetric
Nickel, inc. Cobalt	E478 Gravimetric
Lead 0.05 to 0.10	E478 Atomic Absorption
Iron 0.05 to 1.8	E54
Zinc to 1.0	E478 Atomic Absorption
Zinc 14.0 to 30.0	E478 Titrimetric
Manganese to 1.0	E62
Arsenic 0.02 to 0.5	E62
Antimony 0.02 to 0.1	E62
Phosphorus 0.001 to 0.04	E62
Chromium 0.30 to 0.70	E118

### 19.2 Other Tests:

19.2.1 The product furnished shall conform to specified requirements when subjected to tests in accordance with the following table:

Requirement	ASTM Designation
Grain Size	E112
Tensile strength	E8/E8M
Expansion test	B153
Flattening test	B968/B968M
Reverse bend test	Section 19.2.8
Electromagnetic (eddy-current) test	E243
Hydrostatic test	Section 19.2.10
Pneumatic test	Section 19.2.11

19.2.2 Tension test specimens shall be of the full section of the tube and shall conform to the requirements of the Significance and Use Section of Test Methods E8/E8M.

19.2.3 Whenever tension test results are obtained from both full-size and machined test specimens and they differ, the results obtained from full-size test specimens shall be used to determine conformance to the specification requirements.

19.2.4 Tension test results on material covered by this specification are not seriously affected by variations in speed of testing. A considerable range of testing speed is permissible; however, the range of stressing to the yield strength should not exceed 100 ksi/min [690 MPa/min]. Above the yield strength the movement per minute of the testing machine head under load should not exceed 0.5 in./in. [mm/mm] of gage length (or distance between grips for full-section specimens).

19.2.5 The surface of the test specimen for microscopical examination of grain size shall approximate a radial longitudinal section of the tube.

19.2.6 The surface of the test specimen for microscopical examination of the weld interface shall approximate a transverse section of the tube.

19.2.7 *Flattening Test*—Each test specimen shall be flattened in a press in accordance with Test Method B968/B968M.

19.2.8 *Reverse Bend Test*—The test specimen shall be flattened and bent around a mandrel with a diameter four times the wall thickness, with the mandrel parallel to the length and in contact with the outside surface of the tube. The weld shall be placed at the point of maximum bend.

19.2.9 *Electromagnetic (Eddy-Current) Test:*

19.2.9.1 Either notch-depth or drilled-hole, artificial discontinuity, calibration standards shall be used.

19.2.9.2 The depth of the round bottom traverse notches in the discontinuity, standard used to adjust the sensitivity of the testing unit, are shown in Table 5 or Table 6 with a tolerance of  $\pm 0.0005$  in. ( $\pm 0.013$  mm).

19.2.9.3 The diameters of the drilled holes in the artificial discontinuity, calibration standard used to adjust the sensitivity of the testing unit, are shown in Table 7 or Table 8 and shall not vary by more than  $+ 0.001, - 0.000$  in. [ $+ 0.025, - 0.000$  mm] of the hole diameter specified.

19.2.9.4 The manufacturer shall have the option of using a speed-insensitive, eddy-current unit that is equipped capable of selecting a fraction of the maximum unbalance signal. In such instances, the following percent maximum unbalance signals shall be used:

Standard Tube Size, in.	Maximum-Percent Unbalance Signal Magnitude
Up to $\frac{3}{8}$ , incl	0.2
$\frac{1}{2}$ to 2, incl	0.3
Over 2 to 3, incl	0.4

19.2.9.5 The specimens with discontinuities used to calibrate the testing unit shall be permitted to be placed in the strip from which the tube will be manufactured. These calibration discontinuities will pass through the continuous operations of forming, welding, and eddy-current testing. The testing unit sensitivity required to detect the resultant discontinuities shall be equivalent to or greater than that required to detect the notches or drilled holes.

19.2.9.6 The round-bottom, traverse-notch, calibration discontinuities shall be on the outside tube surface or inside tube surface. The discontinuities, notch or drilled hole, shall be spaced to provide signal resolution adequate for interpretation. Each calibration discontinuity shall be detected by the testing unit.

19.2.9.7 Tubes with discontinuities indicated by the testing unit may, at the option of the manufacturer, be reexamined or retested to determine whether the discontinuity is cause for rejection. Signals that are found to have been caused by minor mechanical damage, soil, or moisture, shall not be cause for rejection of the tubes, provided the tube dimensions are still within prescribed limits and the tube is suitable for its intended application.

19.2.10 *Hydrostatic Test*—Fiber stress shall be determined by the following equation for thin hollow cylinders under tension:

$$P = 2St/(D - 0.8t) \quad (2)$$

where:

$P$  = hydrostatic pressure, psi [MPa];  
 $t$  = thickness of tube wall, in. [mm];  
 $D$  = outside diameter of the tube, in. [mm]; and  
 $S$  = allowable stress of the tube, psi. [MPa].

19.2.10.1 The tube need not be tested at a hydrostatic pressure over 1000 psi [7.0 MPa] unless so specified.

19.2.11 *Pneumatic Test*—Testing shall be such as to permit easy visual detection of leakage, such as a pressure differential method or submerging the tube under water.

## 20. Significance of Numerical Limits

20.1 For purposes of determining compliance with the specified limits for requirements of the properties listed in the following table, an observed value or a calculated value shall be rounded as indicated in accordance with the rounding method of Practice E29.

Property	Rounded Unit for Observed or Calculated Value
Chemical composition	nearest unit in the last righthand place of figures
Tensile strength and yield strength	nearest ksi (Nearest 5 MPa)
Grain size: Up to 0.055 mm, incl, Over 0.055 mm	nearest multiple of 0.005 mm to the nearest 0.010 mm
Expansion:	Nearest 1 %

## 21. Inspection

21.1 The manufacturer or supplier shall inspect and make tests necessary to verify that the furnished product conforms to specification requirements.

21.2 Source inspection of the product by the purchaser may be agreed upon between the manufacturer or supplier and the purchaser as part of the purchase order. In such case, the nature of the facilities needed to satisfy the inspector representing the purchaser shall be included in the agreement. All tests and the inspection shall be conducted so as not to interfere unnecessarily with the operation of the works.

21.3 When mutually agreed upon, the manufacturer or supplier and the purchaser shall conduct the final inspection simultaneously.

## 22. Rejection and Rehearing

22.1 *Rejection:*

22.1.1 Product that fails to conform to the specification requirements, when tested by the purchaser or purchaser's agent, may be rejected.

22.1.2 Rejection shall be reported to the manufacturer or supplier promptly. In addition, a written notification of rejection shall follow.

22.1.3 In case of dissatisfaction with the results of the test upon which rejection is based, the manufacturer or supplier shall have the option to make claim for a rehearing.

22.2 *Rehearing*—As a result of product rejection, the manufacturer or supplier shall have the option to make claim for a retest to be conducted by the manufacturer or supplier and the purchaser. Samples of the rejected product shall be taken in accordance with the product specification and subjected to test by both parties using the test method(s) specified in the product

specification, or, upon agreement of both parties, an independent laboratory may be selected for the test(s) using the test method(s) specified in the product specification.

### 23. Certification

23.1 The purchaser shall be furnished certification that samples representing each lot have been tested and inspected as directed in this specification and requirements have been met.

23.2 DELETED

### 24. Test Reports

24.1 A report of test results shall be furnished.

### 25. Packaging and Package Marking

25.1 *Packaging:*

25.1.1 The product shall be separated by size, composition, and temper and prepared for shipment by common carrier in such a manner as to afford protection from the normal hazards of transportation.

25.2 *Package Marking:*

25.2.1 Each shipping unit shall be legibly marked with the purchase order number, metal or alloy designation, temper, size, shape, gross and net weight, and name of supplier.

25.2.2 When specified in the contract or purchase order, the product specification number shall be shown.

### 26. Keywords

26.1 condenser; copper; copper alloy; copper nickel; evaporator; heat exchanger; welded tube; UNS No. C10800; UNS No. C12200; UNS No. C19400; UNS No. C23000; UNS No. C44300; UNS No. C44400; UNS No. C44500; UNS No. C68700; UNS No. C70400; UNS No. C70600; UNS No. C70620; UNS No. C71000; UNS No. C71500; UNS No. C71520; UNS No. C71640; UNS No. C72200

## SUPPLEMENTARY REQUIREMENTS

The following supplementary requirements shall apply only when specified by the purchaser in the inquiry, contract, or order, for agencies of the U.S. Government.

### S1. Referenced Documents

S1.1 The following documents of the issue in effect on date of material purchase form a part of this specification to the extent referenced herein:

S1.1.1 *ASTM Standard:*

ASTM B900 Practice for Packaging of Copper and Copper Alloy Mill Products for US Government Purchases

*Federal Standards:*

Fed. Std. No. 102 Preservation, Packaging and Packing Levels

Fed. Std. No. 123 Marking for Shipment (Civil Agencies)

Fed. Std. No. 185 Identification Marking of Copper and Copper-Base Alloy Mill Products

S1.1.2 *Military Standard:*

MIL-STD-129 Marking for Shipment and Storage

### S2. Quality Assurance

S2.1 *Responsibility for Inspection:*

S2.1.1 Unless otherwise specified in the contract or purchase order, the manufacturer is responsible for the performance of all inspection and test requirements specified. Except as otherwise specified in the contract or purchase order, the manufacturer may use his own or any other suitable facilities for the performance of the inspection and test requirements

unless disapproved by the purchaser at the time the order is placed. The purchaser shall have the right to perform any of the inspections or tests set forth when such inspections and tests are deemed necessary to assure that the material conforms to prescribed requirements.

### S3. Identification Marking

S3.1 All material shall be properly marked for identification in accordance with Fed. Std. No. 185 except that the ASTM specification number and the alloy number shall be used.

### S4. Preparation for Delivery

S4.1 *Preservation, Packaging, Packing:*

S4.1.1 *Military Agencies*—The material shall be separated by size, composition, grade or class and shall be preserved and packaged, Level A or C, packed, Level A, B, or C as specified in the contract or purchase order, in accordance with the requirements of Practice B900.

S4.1.2 *Civil Agencies*—The requirements of Fed. Std. No. 102 shall be referenced for definitions of the various levels of packaging protection.

S4.2 *Marking:*

S4.2.1 *Military Agencies*—In addition to any special marking required by the contract or purchase order, marking for shipment shall be in accordance with MIL-STD-129.

S4.2.2 *Civil Agencies*—In addition to any special marking required by the contract or purchase order, marking for shipment shall be in accordance with Fed. Std. No. 123.

## APPENDIX

## (Nonmandatory Information)

## X1. DENSITY OF COPPER AND COPPER ALLOYS

X1.1 The densities of the alloys covered by this specification are given in Table X1.1.

TABLE X1.1 Densities

NOTE 1—This information is for reference only.

Copper or Copper Alloy UNS No.	Density, lb/in. <sup>3</sup>	Density, g/cm <sup>3</sup>
C10800, C12200	0.323	8.94
C19400	0.322	8.91
C23000	0.316	8.75
C44300, C44400, C44500	0.308	8.53
C68700	0.301	8.33
C70400	0.323	8.94
C70600, C70620	0.323	8.94
C71000	0.323	8.94
C71500, C71520	0.323	8.94
C71640	0.323	8.94
C72200	0.323	8.94

ASMENORMDOC.COM : Click to view the full PDF of ASME BPVC.II.B (ASME BPVC Section II part B) 2025

INTENTIONALLY LEFT BLANK

# TEST METHOD FOR ULTRASONIC INSPECTION OF ALUMINUM-ALLOY PLATE FOR PRESSURE VESSELS



SB-548



(Identical with ASTM Specification B548-03(2009).)

ASMENORMDOC.COM : Click to view the full PDF of ASME BPVC.II.B (ASME BPVC Section II part B) 2025

# TEST METHOD FOR ULTRASONIC INSPECTION OF ALUMINUM-ALLOY PLATE FOR PRESSURE VESSELS



SB-548



[Identical with ASTM Specification B 548-03(2009).]

## 1. Scope

**1.1** This test method covers pulse-echo ultrasonic inspection of aluminum-alloy plate of thickness equal to or greater than 0.500 in. (12.7 mm) for use in the fabrication of pressure vessels. The ultrasonic test is employed to detect gross internal discontinuities oriented in a direction parallel to the rolled surface such as cracks, ruptures, and laminations, and to provide assurance that only plate that is free from rejectable discontinuities is accepted for delivery.

**1.2** The inspection method and acceptance criteria included in this standard shall be limited to plate of the following aluminum alloys: 1060, 1100, 3003, Alclad 3003, 3004, Alclad 3004, 5050, 5052, 5083, 5086, 5154, 5254, 5454, 5456, 5652, 6061, and Alclad 6061.

**1.3** This test method applies only to ultrasonic tests using pulsed longitudinal waves which are transmitted and received by a search unit containing either a single crystal or a combination of electrically interconnected multiple crystals. Ultrasonic tests employing either the through-transmission or the angle-beam techniques are not included.

**1.4** This test method shall be used when ultrasonic inspection as prescribed herein is required by the contract, purchase order, or referenced plate specification.

**1.5** The values stated in inch-pound units are to be regarded as standard. The values given in parentheses are mathematical conversions to SI units that are provided for information only and are not considered standard.

**1.6** *This standard does not purport to address all of the safety concerns, if any, associated with its use. It is the responsibility of the user of this standard to establish appropriate safety and health practices and determine the applicability of regulatory limitations prior to use.*

## 2. Referenced Documents

**2.1** The following documents of the issue in effect on date of material purchase form a part of this specification to the extent referenced herein:

### 2.2 ASTM Standards:

E114 Practice for Ultrasonic Pulse-Echo Straight-Beam Examination by the Contact Method  
E214 Practice for Immersed Ultrasonic Testing by the Reflection Method Using Pulsed Longitudinal Waves  
E317 Practice for Evaluating Performance Characteristics of Ultrasonic Pulse-Echo Testing Instruments and Systems without the Use of Electronic Measurement Instruments

### 2.3 Other Standards:

ASNT Recommended Practice for Nondestructive Testing Personnel Qualification and Certification—Ultrasonic Testing Method—SNT-TC-1A

## 3. Summary of Method

**3.1** The plate is inspected ultrasonically by scanning one rolled surface with a beam of pulsed longitudinal waves which is oriented in a direction perpendicular to the entry surface of the plate. The ultrasound is transmitted into the plate either by the direct contact, immersion, or liquid-column coupling method. During the scan, an indication representing the first back reflection is observed on the A-scan screen of the test instrument.

**3.2** When the test system sensitivity level is appropriately adjusted, a discontinuity is detected during the scan by noting an isolated indication associated with a loss of the first back reflection indication. The apparent size of the discontinuity is determined by measuring the total area

in the scanned entry surface of the plate where the isolated indication and the loss of back reflection persist. The estimated discontinuity size and location are then compared with suitable acceptance criteria.

NOTE 1 — Additional information describing ultrasonic tests by the direct contact method and by the immersion method is available in Practices E114 and E214.

#### 4. Significance and Use

**4.1** A number of factors such as the condition of the entry and back surfaces of the plate, the inclination of the ultrasonic beam with respect to the entry surface, and the performance characteristics of the test system may cause either a reduction of isolated indications or a substantial loss of back reflection and thereby could seriously impair the reliability of the test procedure outlined in this standard.

**4.2** Accurate evaluations of discontinuity size also may be limited significantly by variations in beam characteristics which exist in most search units. For this reason, discontinuity size as determined by the test procedure outlined in this method is regarded as “apparent” or “estimated” in recognition of the limited quantitative value of the measurement.

**4.3** Because a large number of interacting variables in a test system can adversely influence the results of an ultrasonic test, the actual quantitative effects of detected discontinuities upon the mechanical properties of the inspected plate are difficult to establish. Consequently, this ultrasonic inspection method is not applicable as an exclusive indicator of the ultimate quality and performance of pressure vessels but provides a reliable control of plate quality to avoid failure during the forming process for fabrication of vessels.

#### 5. Apparatus

**5.1 Test Instrument** — Any electronic device that produces pulsed longitudinal waves and displays ultrasonic reflections on an A-scan indicator when used with an appropriate search unit is satisfactory. The instrument shall provide stable, linear amplification of received pulses at a selected test frequency and shall be free from significant interface signal interference at the required sensitivity level.

**5.2 Search Unit** — The search unit recommended for this standard is the flat nonfocusing type, and contains a piezoelectric crystal which generates and receives longitudinal waves at the rated frequency when connected to the test instrument through a suitable coaxial cable. A dual-crystal search unit containing both a transmitting and a receiving crystal in one container may be used provided the test instrument will accommodate two-crystal operation

and the resulting pulse-echo test is equivalent to that obtained with a search unit containing a single-crystal.

**5.2.1** The total effective area of the crystal or combination of crystals in the search unit used for initial scanning shall not be less than 0.4 in.<sup>2</sup> (2.6 cm<sup>2</sup>) nor greater than 3.0 in.<sup>2</sup> (19.4 cm<sup>2</sup>).

**5.2.2** The effective diameter of the round search unit used to evaluate discontinuity size shall not exceed 0.75 in. (19 mm).

NOTE 2 — For control purposes, the performance characteristics of the test instrument and search unit may be established in accordance with procedures outlined in Practice E317.

**5.3 Tank** — For tests by the immersion method, any container is satisfactory that will facilitate the accurate, stable positioning of both the search unit and the plate to be inspected.

**5.4 Scanning Apparatus** — During the inspection procedure, the search unit is supported by any one of the following devices. The scanning apparatus shall permit measurement of both the scan distance and the index distance within ±0.1 in. (±2 mm).

**5.4.1 Manipulator and Bridge** — When a manipulator is used in tests by the immersion method, the manipulator shall adequately support a search tube containing a search unit and shall provide fine adjustment of angle within 1° in two vertical planes that are perpendicular to each other. The bridge shall be of sufficient strength to provide rigid support for the manipulator and shall allow smooth, accurate positioning of the search unit. Special search unit supporting fixtures may be used provided they meet the requirements prescribed for a manipulator and bridge.

**5.4.2 Liquid Coupling Nozzle** — For tests by the liquid-column coupling method, the nozzle is usually positioned manually and shall be capable of containing the couplant while rigidly supporting the search unit with its active surface immersed in the couplant. The couplant distance shall be maintained so that the second couplant reflection is to the right of the first back reflection on the instrument cathode ray tube (CRT). The couplant path shall not vary more than ±¼ in. (6.4 mm) during calibration, initial scanning, and discontinuity evaluation. The recommended minimum inside dimension of the nozzle is 1.0 in. (25 mm) greater than the maximum dimension of the crystal surface in the search unit. Provisions also should be included for adjustment of search unit inclination within 1° in two vertical planes that are perpendicular to each other.

NOTE 3 — Nozzles containing either sealed or unsealed openings may be used for inspecting plate provided the test results obtained with either device are equivalent to those obtained by the immersion method.

**5.4.3 Contact Scanning Unit** — During tests by the contact method, the search unit usually is supported and

positioned manually on the entry surface of the inspected plate. However, special fixtures for contact scanning may be employed provided their use ensures conformance to the requirements in this specification.

**5.5 Couplant** — Clean, deaerated water at room temperature is the recommended couplant for tests either by the immersion method or by the liquid-column coupling technique. Inhibitors or wetting agents or both may be used. For tests by the contact method, the recommended couplant is clean, light-grade oil.

NOTE 4 — Other coupling liquids may be employed for inspecting plate provided their use does not adversely affect test results.

## 6. Personnel Requirements

**6.1** The testing operator performing the ultrasonic examination prescribed in this standard shall be qualified and certified to at least a Level I—Ultrasonic Testing in accordance with the ASNT Recommended Practice SNT-TC-1A.

**6.2** The required documentation supporting qualification and certification of ultrasonic testing operators shall be established by the certifying agency and shall be available upon request by the purchaser.

## 7. Condition of Plate

**7.1** The entry and back surfaces of the inspected plate shall be sufficiently clean, smooth, and flat to maintain a first back reflection amplitude greater than 50% of the initial standardization amplitude while scanning an area in the plate that does not contain significant isolated ultrasonic discontinuities.

**7.2** The inspected plate shall be at room temperature during the test.

## 8. Procedure

**8.1 Preferred Method** — The ultrasonic test may be performed by either the liquid column coupling, the direct contact, or the immersion methods. However, the immersion method is preferred.

**8.1.1** Maintain the couplant distance so that the second couplant reflection is to the right of the first back reflection on the instrument's A-scan display. The couplant path shall not vary more than  $\pm\frac{1}{4}$  in. (6.4 mm) during calibration, initial scanning, and discontinuity evaluation.

**8.2 Test Frequency** — When using any of the three methods listed in 8.1, the recommended test frequency is 5.0 MHz. Other test frequencies between 2.0 MHz and 10.0 MHz may be employed when necessary to minimize possible adverse effects of plate thickness, microstructure,

and test system characteristics upon test results and thereby maintain a clean, easily interpreted A-scan screen pattern throughout the inspection.

**8.3 Sensitivity Standardization** — Standardize the sensitivity level of the test system operating at the selected frequency by adjusting the instrument gain control to obtain a first back reflection amplitude of  $75 \pm 5\%$  of the vertical limit exhibited by the A-scan indicator when the search unit is positioned over an area free from significant discontinuities in the plate to be inspected. During tests by either the immersion method or the liquid column coupling method, adjust the angular alignment of the search unit to obtain a maximum number of back reflections before the final sensitivity level is established.

**8.4 Scanning** — With no further adjustments of the instrument gain controls, locate the search unit over one corner of the plate to be inspected so that the edge of the crystal in the search unit is about 1 in. (25 mm) from either edge of the plate.

**8.4.1** Subsequent to checking the angular alignment of the search unit with respect to the rolled entry surface to ensure a maximum first back reflection, proceed to scan the plate continuously by moving the search unit at a constant scanning rate (see 8.6) from the initial starting position to the opposite edge in a direction perpendicular to the predominant rolling direction of the plate.

**8.4.2** During the scan, note the occurrence of isolated discontinuity indications and monitor the amplitude of the first back reflection by continuously observing the A-scan indicator screen.

NOTE 5 — Auxiliary monitoring devices may be employed in the test system to enhance detection reliability during the scan.

**8.5 Scan Index** — When the initial scan is completed, move the search unit over a predetermined scan index distance in a direction parallel to the predominant rolling direction of the plate and proceed with a second scan along a line parallel to the initial scanning direction while observing the test pattern on the A-scan indicator screen. Calculate the scan index distance as follows:

$$\text{Scan index distance (in.)}, S_i = 0.8 + 0.7 D_s$$

$$\text{Scan index distance (mm)}, S_i = 20 + 0.7 D_s$$

where:

$$D_s = \text{actual crystal diameter.}$$

**8.5.1** Continue the inspection by constantly observing the test pattern on the A-scan indicator while successively scanning the plate at a constant scanning rate in a direction perpendicular to the predominant rolling direction of the plate and indexing the search unit through the index distance calculated in 8.5.

**8.5.2** During the inspection procedure, check the test system sensitivity standardization periodically by noting the amplitude of the first back reflection when the search unit is repositioned over the reference area of the plate and by adjusting the instrument gain control as required to maintain the sensitivity standardization specified previously in 8.3.

**8.6 Scanning Rate** — When the screen pattern on the A-scan indicator is monitored visually by the test operator during the inspection, the scanning rate shall not be greater than 12 in./s (305 mm/s).

NOTE 6 — Scanning rates greater than 12 in./s (305 mm/s) may be employed if auxiliary monitoring apparatus is used to maintain adequate detection reliability.

**8.7 Detection of Discontinuities** — When an isolated ultrasonic indication of amplitude greater than 30% of the A-scan vertical limit is encountered or when the first back reflection indication decreases to an amplitude less than 5% of the vertical limit at any time during the inspection procedure, stop the scan and angulate the search unit to obtain a maximum isolated indication and to determine that the loss of back reflection is not caused by misalignment of the search unit with respect to the plate.

**8.7.1** To ensure that the loss of back reflection is not caused by surface interference, check the condition of both the entry and back surfaces of the plate at the location where a substantial (95% or greater) loss of back reflection occurs.

**8.7.2** Either a maximized isolated ultrasonic indication exhibiting an amplitude greater than 50% of the amplitude of the initial first back reflection used for standardization, or a substantial loss of the first back reflection indication not attributable to either search unit misalignment or surface interference, is an indication of an internal discontinuity.

NOTE 7 — Isolated indications occurring midway between the entry surface indication and the first back reflection may cause a second indication at the location of the first back reflection on the A-scan screen. When this condition is verified by checking the multiple back reflection pattern, a complete loss of the first back reflection can be assumed.

**8.8 Estimation of Discontinuity Size** — Note the location of the search unit where the scan was stopped when either an isolated indication or a loss of back reflection was observed.

**8.8.1** Using a search unit containing a crystal of effective diameter no greater than 0.75 in. (19 mm), make an evaluation scan of an entire 6-in. (152-mm) square area which is centered around the point on the plate entry surface where the scan was discontinued. The recommended index distance for this evaluation is as follows:  $S_i$  (in. or mm) =  $0.7 D_s$ , where  $D_s$  is the actual diameter of the search unit crystal.

**8.8.2** To determine the apparent size of the discontinuity, mark each location corresponding to the center of the search unit on the plate entry surface where a  $95 \pm 5\%$  loss of first back reflection is observed or where the isolated indication exhibits an amplitude equal to  $50 \pm 5\%$  of the amplitude of the initial first back reflection established during the standardization procedure outlined in 8.3.

**8.8.3** Continue to mark the location of the search unit at each point where either or both of the discontinuity conditions specified in paragraph 8.8.2 are observed. The entire discontinuity shall be outlined even if it extends beyond the original 6-in. (152-mm) square evaluation scan area.

**8.8.4** The estimated discontinuity size is the area defined by the boundary consisting of successive marks as established by this procedure.

NOTE 8 — Automatic recording devices may be used to establish the estimated size of a discontinuity provided the recorded results are equivalent to those obtained by the procedure presented in 8.8.

**8.9** When the estimated size of a detected discontinuity is determined, return the search unit to the original stopping position and continue the initial scan to complete the inspection.

## 9. Acceptance Standards

**9.1** Upon completing the inspection procedure, measure the longest dimension of each marked area representing a detected discontinuity. Also, when an engineering drawing showing the part to be fabricated from the plate is supplied, compare the locations of the discontinuities with the dimensions on the drawing.

**9.2** If the longest dimension of the marked area representing a discontinuity causing a complete loss of back reflection (95% or greater) exceeds 1.0 in. (25 mm), the discontinuity is considered to be significant and the plate shall be subject to rejection.

**9.3** If the length of the marked area representing a discontinuity causing an isolated ultrasonic indication without a complete loss of back reflection (95% or greater) exceeds 3.0 in. (76 mm), the discontinuity is considered to be significant and the plate shall be subject to rejection.

**9.4** If each of two marked areas representing two adjacent discontinuities causing isolated ultrasonic indications without a complete loss of back reflection (95% or greater) is longer than 1.0 in., and if they are located within 3.0 in. of each other, the proximity between the two discontinuities is considered to be significant, and the plate shall be subject to rejection.

NOTE 9 — A template containing a 1.0-in. diameter hole and a 3.0-in. diameter hole is a convenient device for rapidly establishing the significance of discontinuities. If the discontinuities described in 9.2 and 9.3

FIG. 1 STAMP FOR IDENTIFYING ACCEPTABLE PLATE

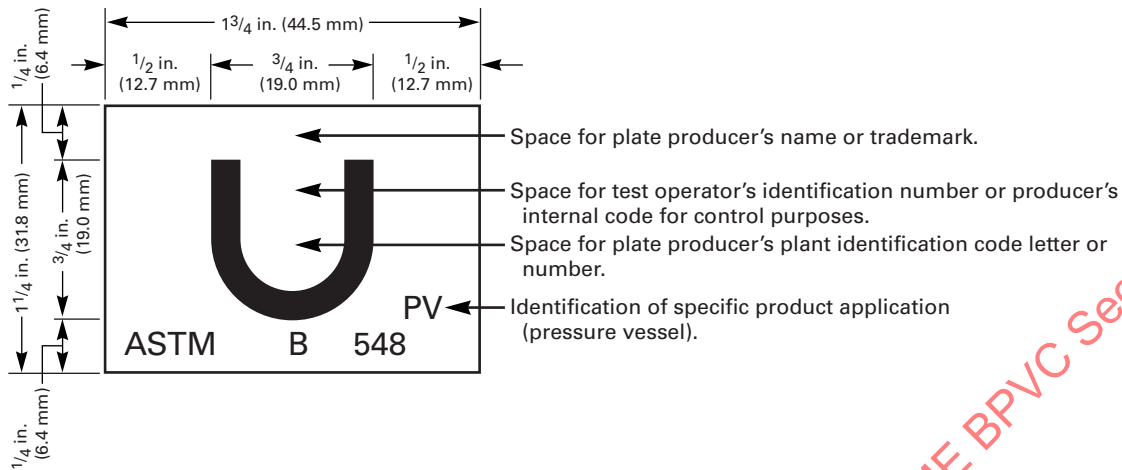

cannot be totally enclosed within either the 1.0-in. diameter circle or the 3.0-in. diameter circle, respectively, then the plate containing such discontinuities shall be subject to rejection. Similarly, if any portions of two adjacent discontinuities greater than 1.0 in. in length as in accordance with 9.4 appear within the 3.0-in. diameter circle, the plate shall be subject to rejection.

**9.5** A plate containing significant discontinuities of rejectable size shall be acceptable if it is established by the purchaser that the discontinuities will be removed from the plate by machining during the subsequent fabrication process.

**9.6** Upon specific consent of the purchaser, a plate with significant discontinuities may be accepted if repaired by welding.

## 10. Report

**10.1** When required by the purchaser, a report shall be prepared and shall include the date of test and a list of parameters including the type (model number) of instrument and search unit, the test method, frequency, and the couplant employed for the inspection.

**10.2** Preparation of a drawing showing the location of all significant discontinuities in the inspected plate is recommended when the ultimate rejection or acceptance of the plate is to be determined by negotiation between the manufacturer and the purchaser.

**10.3** The identification of an acceptable plate is desirable and is recommended. For this purpose, a suitable stamp should be employed to indicate conformance to this ultrasonic standard. The recommended stamp for identifying acceptable plate is shown in Fig. 1.

# SPECIFICATION FOR ZIRCONIUM AND ZIRCONIUM ALLOY BAR AND WIRE



**SB-550/SB-550M**



(Identical with ASTM Specification B550/B550M-07(2019).)

ASMENORMDOC.COM :: Click to view the full PDF of ASME BPVC.II.B (ASME BPVC Section II part B) 2025

# Specification for Zirconium and Zirconium Alloy Bar and Wire

## 1. Scope

1.1 This specification covers three grades of zirconium and zirconium alloy bar and wire.

1.2 Unless a single unit is used, for example corrosion mass gain in  $\text{mg}/\text{dm}^2$ , the values stated in either inch-pound or SI units are to be regarded separately as standard. The values stated in each system are not exact equivalents; therefore each system must be used independently of the other. SI values cannot be mixed with inch-pound values.

1.3 The following precautionary caveat pertains only to the test methods portions of this specification. *This standard does not purport to address all of the safety concerns, if any, associated with its use. It is the responsibility of the user of this standard to establish appropriate safety, health, and environmental practices and determine the applicability of regulatory limitations prior to use.*

1.4 *This international standard was developed in accordance with internationally recognized principles on standardization established in the Decision on Principles for the Development of International Standards, Guides and Recommendations issued by the World Trade Organization Technical Barriers to Trade (TBT) Committee.*

## 2. Referenced Documents

2.1 *ASTM Standards:*

E8 Test Methods for Tension Testing of Metallic Materials [Metric] E0008\_E0008M

E29 Practice for Using Significant Digits in Test Data to Determine Conformance with Specifications

## 3. Terminology

3.1 *Definitions of Terms Specific to This Standard:*

3.1.1 *annealed, n*—denotes material that exhibits a recrystallized grain structure.

3.2 *Lot Definitions:*

3.2.1 *bar and wire, n*—a lot shall consist of a material of the same size, shape, condition, and finish produced from the same ingot or powder blend by the same reduction schedule and the same heat treatment parameters. Unless otherwise agreed between manufacturer and purchaser, a lot shall be limited to the product of an 8 h period for final continuous anneal, or to a single furnace load for final batch anneal.

3.2.2 *Forms:*

3.2.2.1 *bar, n*—a hot rolled, forged, or cold worked semi-finished solid section product whose cross sectional area is equal to or less than  $16 \text{ in.}^2$  [ $10\,323 \text{ mm}^2$ ]; rectangular bar must be less than or equal to 10 in. [ $254 \text{ mm}$ ] in width and greater than 0.1875 in. [ $4.8 \text{ mm}$ ] in thickness.

3.2.2.2 *wire, n*—rounds, flats, or special shapes less than or equal to 0.1875 in. [ $4.8 \text{ mm}$ ] in thickness or major dimension.

## 4. Classification

4.1 The bar or wire is to be furnished in three grades as follows:

4.1.1 *Grade R60702*—Unalloyed zirconium.

4.1.2 *Grade R60704*—Zirconium-tin.

4.1.3 *Grade R60705*—Zirconium-niobium.

## 5. Ordering Information

5.1 Orders for material under this specification should include the following information:

5.1.1 Quantity (weight or number of pieces),

5.1.2 Name of material (zirconium bar or wire) (Table 1),

5.1.3 Grade number (see 4.1),

5.1.4 Standard designation and year of issue, for example ASTM Specification B550/B550M – 07, and

5.1.5 Additions to the specification as required.

NOTE 1—A typical ordering description is as follows: 1000 lb [500 kg] zirconium cold drawn bar, 0.35 in. [ $10 \text{ mm}$ ] in diameter by 10 ft [ $3 \text{ m}$ ] in length, ASTM B550 – 01, Grade R60702.

## 6. Materials and Manufacture

6.1 Bar and wire covered by this specification shall be formed with conventional fabrication methods and equipment found in primary ferrous and nonferrous metal plants.

TABLE 1 Product Sections and Size

Product	Section	Size
Bars:	Hot-finished round, squares, octagons, and hexagons	¼ in. [6.4 mm] and over in diameter or size
	Hot-finished flats	¼ in. [6.4 mm] to 10 in. [250 mm], incl. in width, and ½ in. [3.2 mm] and over in thickness
	Cold-finished rounds, squares, octagons, hexagons, and shapes	Over ½ in. [13 mm] in diameter or size <sup>A</sup>
Wire:	Cold-finished flats	⅜ in. [9.5 mm] and over in width, <sup>B</sup> and ⅛ in. [3.2 mm] and over in thickness <sup>C</sup>
	Cold-finished rounds, squares, octagons, hexagons, and shapes	½ in. [13 mm] and under in diameter or size
	Cold-finished flats	⅛ in. [1.6 mm] to under ⅜ in. [9.5 mm] in width, and 0.010 in. [25 mm] to under ⅜ in. [4.8 mm] in thickness

<sup>A</sup> Sizes ½ in. [13 mm] and under are wire when in coils, and cut wire when finished in straight lengths.

<sup>B</sup> Widths less than ⅜ in. [9.5 mm] and thicknesses less than ⅜ in. [4.8 mm] are generally described as flat wire.

<sup>C</sup> Thickness ⅛ in. [3.2 mm] to under ⅜ in. [4.8 mm] can be cold-rolled strip as well as bar.

TABLE 2 Condition

Form	Condition
Bars	hot finished
	hot finished and annealed
	cold finished
Wire	cold finished and annealed
	cold finished
	cold finished and annealed

6.2 The products covered include the sections and sizes shown in Table 1.

6.3 Bar and wire will be supplied in the conditions prescribed in Table 2.

## 7. Chemical Composition

7.1 The material shall conform to the requirements as to chemical composition prescribed in Table 3.

7.2 The manufacturer's ingot analysis shall be considered the chemical analysis for bar and wire, except for hydrogen and nitrogen, which shall be determined on the finished product.

7.3 When requested by the purchaser and stated in the purchase order, a product analysis for any elements listed in Table 3 shall be made on the finished product.

7.3.1 The manufacturer's analysis shall be considered as verified if the check analysis confirms the manufacturer's reported values within the tolerances prescribed in Table 4.

## 8. Mechanical Properties

8.1 The annealed material shall conform to the requirements for mechanical properties, at room temperature, as prescribed in Table 5. Wire supplied for welding applications shall be furnished with a temper suitable for uniform feeding in semiautomatic or automatic welding equipment.

## 9. Permissible Variations in Dimensions

9.1 Unless otherwise specified, all bar or wire shall conform to the permissible variations in dimensions prescribed in Tables 6-14, as follows:

9.1.1 Table 6, Dimensional Tolerances for Hot-Finished Rounds, Squares, Octagons, and Hexagons.

9.1.2 Table 7, Dimensional Tolerances in Hot-Rolled Flat Bars.

9.1.3 Table 8, Permissible Variations in Sectional Dimensions for Cold-Finished Bars in Rounds, Hexagons, Octagons, and Squares.

9.1.4 Table 9, Permissible Variations in Width and Thickness for Cold-Finished Bars in Flats.

9.1.5 Table 10, Permissible Variations in Sectional Dimensions for Wire.

9.1.6 Table 11, Permissible Variations in Thickness and Width for Cold-Finished Flat Wire.

9.1.7 Table 12, Permissible Variations in Length for Hot-Finished or Cold-Finished Bars.

9.1.8 Table 13, Permissible Variations in Length for Round and Shape, Straightened and Cut Wire, and Exact Length Resheared Wire.

9.1.9 Table 14, Permissible Variations in Straightness for Hot- or Cold-Finished Bars.

## 10. Workmanship, Finish, and Appearance

10.1 Bars in the hot-finished condition which will conform to the tolerances prescribed in Tables 6 and 7, shall be furnished with one of the following finishes as designated on the purchase order:

- 10.1.1 Not descaled,
- 10.1.2 Mechanically descaled,
- 10.1.3 Mechanically descaled and pickled, and
- 10.1.4 Turned (round bars only).

10.2 Bars and wire in cold-finished condition that will conform to the tolerances prescribed in Tables 8-12, shall be furnished with one of the following finishes as designated on the purchase order.

- 10.2.1 Cold drawn or cold rolled, or swaged,
- 10.2.2 Turned (round bars only),
- 10.2.3 Centerless ground (round bars only), and
- 10.2.4 Polished (round bars only).

10.3 Bars or wire shall be free of cracks, seams, slivers, blisters, burrs, and other injurious imperfections in accordance with standards of acceptability agreed upon between the manufacturer and the purchaser.

## 11. Significance of Numerical Limits

11.1 For the purpose of determining compliance with the specified limits for requirements of the properties listed in the

TABLE 3 Chemical Requirements<sup>A</sup>

Element	Composition, %		
	Grades R60702	Grades R60704	Grades R60705
Zirconium + hafnium, min	99.2	97.5	95.5
Hafnium, max	4.5	4.5	4.5
Iron + chromium	0.2 max	0.2 to 0.4	0.2 max
Tin	...	1.0 to 2.0	...
Hydrogen, max	0.005	0.005	0.005
Nitrogen, max	0.025	0.025	0.025
Carbon, max	0.05	0.05	0.05
Niobium	...	...	2.0 to 3.0
Oxygen, max	0.16	0.18	0.18

<sup>A</sup> By agreement between the purchaser and the manufacturer, analysis may be required and limits established for elements and compounds not specified in the table of chemical composition.

TABLE 4 Permissible Variation in Check Analysis Between Different Laboratories

Element	Permissible Variation in Product Analysis, %
Hydrogen	0.002
Nitrogen	0.01
Carbon	0.01
Hafnium	0.1
Iron + chromium	0.025
Tin	0.05
Niobium	0.05
Oxygen	0.02

TABLE 5 Tensile Requirements<sup>A</sup>

	Grades		
	R60702	R60704	R60705
Tensile Strength, min, ksi (MPa)	55 [380]	60 [415]	80 [550]
Yield Strength, min, ksi (MPa)	30 [205]	35 [240]	55 [380]
Elongation in 2 in. or 50 mm min, % <sup>B</sup>	16	14	16

<sup>A</sup> For bar only.

<sup>B</sup> When a sub-size specimen is used, the gage length shall be as specified in Test Methods E8 for the specimen.

TABLE 6 Dimensional Tolerances for Hot-Finished Rounds, Squares, Octagons, and Hexagons

Specified Size, in. [mm]	Variation in Size, in. [mm]		Out of Round, Out of Square, in. [mm]
	Over	Under	
Up–0.500 [13]	+0.030	–0 [+0.75]	0.025 [0.64]
Over 0.500–1.000 [13–25]	+0.050	–0 [+1.3]	0.040 [1]
Over 1.000–2.000 [25–50]	+0.070	–0 [+1.8]	0.060 [1.5]
Over 2.000–4.000 [50–100]	+0.150	–0 [+3.8]	0.080 [2]
Over 4.000–6.000 [100–150]	+0.250	–0 [+6.4]	0.100 [2.5]

following table, an observed value or a calculated value shall be rounded as indicated in accordance with the rounding methods of Practice E29.

Property	Rounded Unit for Observed or Calculated Value
Chemical composition and tolerances (when expressed as decimals)	nearest unit in the last right-hand place of figures of the specified limit
Tensile strength and yield strength	nearest 1000 psi (10 MPa)
Elongation	nearest 1 %

12. Number of Tests and Retests

12.1 One longitudinal tension test shall be made from each lot of bar and rod, see 13.1.

12.2 One chemistry test for hydrogen and nitrogen content shall be made from each lot of finished product, see 13.2.

TABLE 7 Dimensional Tolerances in Hot-Rolled Flat Bars

Thickness, in. [mm]	Variation in Thickness, in. [mm]		Variation in Width, <sup>A</sup> in. [mm]	
	Over	Under	Over	Under
Up–0.150 [3.8]	+0.020	–0 [+0.5]	1/16	–0 [3.2]
Over 0.150–0.250 [3.8–6.3]	+0.030	–0 [+0.75]	3/32	–0 [4.0]
Over 0.250–0.350 [6.3–8.9]	+0.040	–0 [+1.0]	3/16	–0 [4.8]
Over 0.350–0.450 [8.9–11.4]	+0.050	–0 [+1.3]	7/32	–0 [5.6]
Over 0.450–0.550 [11.4–14]	+0.070	–0 [+1.8]	<sup>B</sup>	<sup>B</sup>
Over 0.550–1.500 [14–38]	+0.080	–0 [+2.0]	<sup>B</sup>	<sup>B</sup>
Over 1.500 [38]	<sup>B</sup>	<sup>B</sup>	<sup>B</sup>	<sup>B</sup>

<sup>A</sup> For bars sheared from plate, width tolerances shall be as follows:

<sup>B</sup> Depends on size and quantity ordered.

Specified Thickness, in. [mm]	Width Tolerances, in. [mm]			
	Over		Under	
Over 0.100–0.150	1/16	[1.6]	1/16	[1.6]
Over 0.150–0.250	5/64	[2.0]	5/64	[2.0]
Over 0.250–0.350	3/32	[2.4]	3/32	[2.4]
Over 0.350–0.450	7/64	[2.8]	7/64	[2.8]
Over 0.450–0.550	1/8	[3.2]	1/8	[3.2]
Over 0.550–0.650	5/32	[4.0]	5/32	[4.0]

TABLE 8 Permissible Variations in Sectional Dimensions for Cold-Finished Bars in Rounds, Hexagons, Octagons, and Squares

Specified Size, in. [mm]	Permissible Variation, in. <sup>A</sup> [mm]				
	Over		Under		
	Rounds				
Over 1/2 –1, incl	[13–25]	0.002	[0.05]	0.002	[0.05]
1–1 1/2, excl	[25–38]	0.0025	[0.06]	0.0025	[0.06]
1 1/2–4, incl <sup>B</sup>	[38–100]	0.003	[0.08]	0.003	[0.08]
Hexagons, Octagons, and Squares					
Over 1/2 –1, incl	[13–25]	0		0.004	[0.10]
Over 1–2, excl	[25–50]	0		0.006	[0.15]
Over 2–3, incl	[50–75]	0		0.008	[0.20]
Over 3	[75]	0		0.010	[0.25]

<sup>A</sup> When it is necessary to heat treat or heat treat and pickle after cold finishing, because of special hardness or mechanical property requirements, tolerances are double those shown in the table.

<sup>B</sup> For permissible variations on sizes over 4 in. [100 mm] the manufacturer should be consulted.

12.3 Retests:

12.3.1 If any sample or specimen exhibits obvious surface contamination or improper preparation disqualifying it as a truly representative sample, it shall be discarded and a new sample or specimen substituted.

12.3.2 If the results of any tests of any lot do not conform to the requirements specified, retests shall be made on additional samples from the same lot, each of which shall conform to the requirements specified.

**TABLE 9 Permissible Variations in Width and Thickness for Cold-Finished Bars in Flats**

Width, in. [mm]	Permissible Variations in Width for Thicknesses Given, Over and Under, in. <sup>A</sup> [mm]	
	Width	
	¼ [6.4] and under	Over ¼ [6.4]
¾ –1, incl	0.004 [0.10]	0.002 [0.05]
Over 1–2, incl	0.006 [0.15]	0.003 [0.08]
Over 2–3, incl	0.008 [0.20]	0.004 [0.10]
Over 3–4½, incl <sup>B</sup>	0.010 [0.25]	0.005 [0.13]
Thickness, in. [mm]	Permissible Variations in Thickness Over and Under, in. <sup>A</sup> [mm]	
	Thickness	
	¾ –1, incl	Over 1–2, incl
¾ –1, incl	[3.2–25]	0.002 [0.05]
Over 1–2, incl	[25–50]	0.003 [0.08]
Over 2–3, incl	[50–75]	0.004 [0.10]
Over 3–4½, incl <sup>B</sup>	[75–115]	0.005 [0.13]

<sup>A</sup> When it is necessary to heat treat and pickle after cold finishing, because of hardness or mechanical property requirements, tolerances are double those shown in the table.

<sup>B</sup> For permissible variations on widths and thicknesses over 4½ in. [115 mm] the manufacturer should be consulted.

**TABLE 10 Permissible Variations in Sectional Dimensions for Wire<sup>A</sup>**

Specified Size, in. [mm]	Permissible Variation, in. [mm]	
	Over	Under
Drawn, Centerless Ground, Centerless Ground and Polished Round Wire, and Square Wire <sup>B</sup>		
½ [13]	0.002 [0.05]	0.002 [0.05]
Under ½ –5/16, incl [13–18]	0.0015 [0.04]	0.0015 [0.04]
Under 5/16 –0.044, incl [8–1.1]	0.001 [0.025]	0.001 [0.025]
Under 0.044–0.033, incl [1.1–0.8]	0.0008 [0.020]	0.0008 [0.020]
Under 0.033–0.024, incl [0.8–0.6]	0.0005 [0.013]	0.0005 [0.013]
Under 0.024–0.012, incl [0.6–0.3]	0.0004 [0.010]	0.0004 [0.010]
Under 0.012–0.008, incl [0.3–0.2]	0.0003 [0.008]	0.0003 [0.008]
Under 0.008–0.007, incl [0.2–1.8]	0.0002 [0.005]	0.0002 [0.005]
Under 0.007–0.00476, incl [0.18–0.12]	0.0002 [0.005]	0.0002 [0.005]
Under 0.00476–0.003, incl [0.12–0.08]	0.0001 [0.003]	0.0001 [0.003]
Drawn Wire in Hexagons and Octagons <sup>C</sup>		
½	0	0.004 [0.10]
Under ½ –5/16, incl	0	0.003 [0.08]
Under 5/16 –1/8, incl	0	0.002 [0.05]
Wire for Which the Final Operation is a Surface Treatment to Remove Scale or Drawing Lubricant		
½	0.004 [0.10]	0.004 [0.10]
Under ½ –5/16, incl	0.003 [0.08]	0.003 [0.08]
Under 5/16 –0.044, incl	0.002 [0.05]	0.002 [0.05]
Under 0.044–0.033, incl	0.0013 [0.03]	0.0013 [0.03]
Under 0.033–0.024, incl	0.0008 [0.02]	0.0008 [0.02]

<sup>A</sup> Manufacturers should be consulted for all tolerances for half-round, oval, and half-oval wires.

<sup>B</sup> The maximum out-of-round tolerance for round wire is one half of the total size tolerance shown in the above table.

<sup>C</sup> Dimensions are across flats.

### 13. Test Methods

13.1 *Tension Tests*—The tension test shall be conducted in accordance with Test Methods E8. Determine the yield strength by the offset (0.2 %) method. Determine the tensile properties using a strain rate of 0.003 to 0.007 in./in. [mm/mm]/min through the yield strength. After the yield strength has been exceeded, the cross-head speed may be increased to approximately 0.05 in./in. [mm/mm]/min to failure.

13.2 *Chemical Tests*—The chemical analyses shall be conducted by the standard techniques normally used by the manufacturer.

### 14. Inspection

14.1 The manufacturer shall inspect the material covered by this specification prior to shipment. If so specified in the purchase order, the purchaser or his representative may witness the testing and inspection of the material at the place of manufacture. In such cases the purchaser shall state in his purchase order which tests he desires to witness. The manufacturer shall give ample notice to the purchaser as to the time and place of the designated tests. If the purchaser's representative does not present himself at the time agreed upon for the testing, the manufacturer shall consider the requirement for purchaser's inspection at the place of manufacture to be waived.

14.2 The manufacturer shall afford the inspector representing the purchaser, without charge, all reasonable facilities to satisfy him that the material is being furnished in accordance with this specification. This inspection shall be so conducted as not to interfere unnecessarily with the operation of the works.

### 15. Rejection

15.1 Rejection for failure of the material to meet the requirements of this specification shall be reported to the manufacturer. Unless otherwise specified, rejected material may be returned to the manufacturer at the manufacturer's expense unless the purchaser receives, within three weeks of the notice of rejection, other instructions for disposition.

### 16. Certification

16.1 A producer or supplier shall furnish the purchaser with a certificate that the material was manufactured, sampled, tested, and inspected in accordance with this specification and has been found to meet the requirements. The certificate shall include a report of the test results.

### 17. Referee

17.1 In the event of disagreement between the manufacturer and the purchaser on the conformance of the material to the requirements of this specification or any special test specified by the purchaser, a mutually acceptable referee shall perform the tests in question. The results of the referee's testing shall be used in determining conformance of the material to this specification.

### 18. Product Marking

18.1 Each bundle, box, or coil shall be marked or tagged legibly and conspicuously with the purchase order or contract number, manufacturer's private identification mark, the ASTM designation, the grade, size, ingot number, and gross, net, and tare weights.

### 19. Packaging and Package Marking

19.1 All material shall be boxed, crated, banded on skids, or bundled in such a manner as to assure safe delivery to its destination when properly transported by common carrier.

### 20. Keywords

20.1 bar; wire; zirconium; zirconium alloy

**TABLE 11 Permissible Variations in Thickness and Width for Cold-Finished Flat Wire**

Specified Width, in.	Permissible Variation in Thickness for Given Thickness, Over or Under, in. [mm]			Permissible Variation in Width, in. [mm]	
				Over	Under
	Under 0.029 [0.74]	0.029 [0.75]–0.035 [0.89], excl	0.035 [0.89]– $\frac{3}{16}$ [4.80], incl		
Under $\frac{3}{8}$ [9.5] to $\frac{1}{16}$ [1.6], incl	0.001 [0.025]	0.0015 [0.04]	0.002 [0.05]	0.005 [0.125]	0.005 [0.125]

**TABLE 12 Permissible Variations in Length for Hot-Finished or Cold-Finished Bars**

Specified Sizes of Rounds, Squares, Hexagons, Octagons, and Widths of Flats, in.	Permissible Variation in Length, in. [mm]			
	To 12 ft [3.5 m], incl		Over 12 ft [3.5 m] to 25 ft [7.6], incl	
	Over	Under	Over	Under
To 2, incl [50]	$\frac{1}{2}$ [13]	0	$\frac{3}{4}$ [20]	0
Over 2–4, incl [50–100]	$\frac{3}{4}$ [20]	0	1 [25]	0
Over 4–6, incl [100–150]	1 [25]	0	$1\frac{1}{4}$ [32]	0
Over 6–9, incl [150–225]	$1\frac{1}{4}$ [32]	0	$1\frac{1}{2}$ [38]	0
Over 9–12, incl [225–300]	$1\frac{1}{2}$ [38]	0	2 [50]	0
Machine-Cut After Machine Straightening				
To 3, incl	$\frac{1}{8}$ [3.2]	0	$\frac{3}{16}$ [4.8]	0
Over 3–6, incl	$\frac{3}{16}$ [4.8]	0	$\frac{1}{4}$ [6.4]	0
Over 6–9, incl	$\frac{1}{4}$ [6.4]	0	$\frac{5}{16}$ [8.0]	0
Over 9–12, incl	$\frac{1}{2}$ [13.0]	0	$\frac{1}{2}$ [13.0]	0

**TABLE 13 Permissible Variations in Length for Round and Shape, Straightened and Cut Wire, and Exact Length Resheared Wire**

Diameter, in. [mm]	Length, ft [m]	Permissible Variation, in.	
		Over	Under
0.125 [3.2] and under	Up to 12 [3.5], incl	$\frac{1}{16}$ [1.6]	0
0.125 [3.2] and under	Over 12 [3.5]	$\frac{1}{8}$ [3.2]	0
Over 0.125 [3.2] to 0.500 [13.0], incl	Under 3 [1.0]	$\frac{1}{32}$ [0.8]	0
Over 0.125 [3.2] to 0.500 [13.0], incl	3 to 12, incl [1.0–3.5]	$\frac{1}{16}$ [1.6]	0
Over 0.125 [3.2] to 0.500 [13.0], incl	Over 12 [3.5]	$\frac{1}{8}$ [3.2]	0

**TABLE 14 Permissible Variations in Straightness for Hot- or Cold-Finished Bars<sup>A</sup>**

Bars	Permissible Variation
Hot finished	$\frac{1}{8}$ in. [3.2] in any 5 ft [1.5 m]; but may not exceed $\frac{1}{8}$ [0.4] × (number of feet [meters] in length/5)
Cold finished	$\frac{1}{16}$ in. [1.6] in any 5 ft [1.5 m]; but may not exceed $\frac{1}{16}$ [0.2] × (number of feet [meters] in length/5)

<sup>A</sup> The measurement is taken on the concave side of the bar with a straight edge. Unless otherwise specified, hot-finished or cold-finished bars for machining purposes are furnished machine-straightened to the tolerances specified in the Table.

# SPECIFICATION FOR ZIRCONIUM AND ZIRCONIUM ALLOY STRIP, SHEET, AND PLATE



**SB-551/SB-551M**



(Identical with ASTM Specification B551/B551M-12(2017).)

ASMENORMDOC.COM : Click to view the full PDF of ASME BPVC.II.B (ASME BPVC Section II part B) 2025

# Specification for Zirconium and Zirconium Alloy Strip, Sheet, and Plate

## 1. Scope

1.1 This specification covers five grades of zirconium strip, sheet, and plate.

1.2 Unless a single unit is used, for example corrosion mass gain in  $\text{mg}/\text{dm}^2$ , the values stated in either inch-pound or SI units are to be regarded separately as standard. The values stated in each system are not exact equivalents; therefore each system must be used independently of the other. SI values cannot be mixed with inch-pound values.

1.3 The following precautionary caveat pertains only to the test method portions of this specification: *This standard does not purport to address all of the safety concerns, if any, associated with its use. It is the responsibility of the user of this standard to establish appropriate safety, health, and environmental practices and determine the applicability of regulatory limitations prior to use.*

1.4 *This international standard was developed in accordance with internationally recognized principles on standardization established in the Decision on Principles for the Development of International Standards, Guides and Recommendations issued by the World Trade Organization Technical Barriers to Trade (TBT) Committee.*

## 2. Referenced Documents

### 2.1 ASTM Standards:

E8/E8M Test Methods for Tension Testing of Metallic Materials

E29 Practice for Using Significant Digits in Test Data to Determine Conformance with Specifications

E290 Test Methods for Bend Testing of Material for Ductility

## 3. Terminology

### 3.1 Definitions:

3.1.1 *annealed, n*—denotes material that exhibits a recrystallized grain structure.

### 3.2 Lot Definition:

3.2.1 *lot, n*—a lot shall consist of a material of the same size, shape, condition, and finish produced from the same ingot or powder blend by the same reduction schedule and the same heat treatment parameters. Unless otherwise agreed between manufacturer and purchaser, a lot shall be limited to the product of an 8 h period for final continuous anneal, or to a single furnace load for final batch anneal.

### 3.3 Forms:

3.3.1 *strip, n*—a flat product, may be supplied in coil, less than 6 in. [150 mm] in width and from 0.005 in. [0.13 mm] to 0.188 in. [4.8 mm] in thickness.

3.3.2 *sheet, n*—a flat product 6 in. [150 mm] or more in width and from 0.005 in. [0.13 mm] to 0.188 in. [4.8 mm] in thickness.

3.3.3 *plate, n*—a flat product more than 0.125 in. [3.2 mm] in thickness.

## 4. Classification

4.1 The strip, sheet, or plate is to be furnished in five grades as follows:

4.1.1 *Grade R60700*—Low oxygen zirconium.

4.1.2 *Grade R60702*—Unalloyed zirconium.

4.1.3 *Grade R60704*—Zirconium-tin.

4.1.4 *Grade R60705*—Zirconium-niobium.

4.1.5 *Grade R60706*—Zirconium-niobium.

## 5. Ordering Information

5.1 Orders for material under this specification should include the following information, as applicable:

5.1.1 Standard designation and year of issue,

5.1.2 Quantity (weight or number of pieces),

5.1.3 Lot definition for continuous anneal, if applicable (3.2.1),

5.1.4 Form (3.3) and dimensions,

5.1.5 Grade (4.1),

5.1.6 Metallurgical condition, if not in the recrystallized annealed condition (6.3),

- 5.1.7 Chemical analysis of elements not listed (7.1.4),
- 5.1.8 Product analysis (7.1.3 and 7.3.1),
- 5.1.9 Tensile test temperature (8.1),
- 5.1.10 Material condition and finish (9.1 – 9.5),
- 5.1.11 Workmanship and appearance (11.1 and 11.3),
- 5.1.12 Purchaser inspection (15.1 and 15.2),
- 5.1.13 Rejection and referee (16.2),
- 5.1.14 Product marking, (18.1 and 18.1.1),
- 5.1.15 Packaging and package marking (19.1),
- 5.1.16 Additions to the specification and supplementary requirements, if required, and
- 5.1.17 Additional requirements for explosion cladding, if applicable (Supplementary Requirements S.1).

NOTE 1—A typical ordering description is as follows: 9000-lb [5000 kg] zirconium sheet, 0.098 in. [2.5 mm] by 12 in. [300 mm] by 144 in. [3.5 m], ASTM B551/B551M-07, Grade R60705.

## 6. Materials and Manufacture

6.1 Material covered by this specification shall be made from ingots that are produced by vacuum or plasma arc melting, vacuum electron-beam melting, a combination of these three methods or other melting processes conventionally used for reactive metals. All processes to be done in furnaces usually used for reactive metals.

6.2 The various mill products covered by this specification shall be formed with the conventional extrusion, forging, or rolling equipment normally found in primary ferrous and nonferrous plants.

6.3 The strip, sheet, and plate shall be supplied in the recrystallized annealed condition unless otherwise specified in the purchase order.

## 7. Chemical Composition

7.1 The material covered by this specification shall conform to the chemical composition requirements prescribed in Table 1.

7.1.1 The elements listed in Table 1 are intentional alloy additions or elements which are inherent to the manufacture of sponge, ingot or mill product.

7.1.2 Elements intentionally added to the melt must be identified, analyzed, and reported in the chemical analysis.

7.1.3 Elements other than those listed in Table 1 are deemed to be capable of occurring in the grades listed in Table 1 by and only by way of unregulated or unanalyzed scrap additions to the ingot melt. Therefore, product analysis for elements not listed in Table 1 shall not be required unless specified and shall be considered to be in excess of the intent of this specification.

7.1.4 When agreed upon by producer and purchaser and requested by the purchaser in his written purchase order, chemical analysis shall be completed for specific residual elements not listed in this specification.

7.2 The manufacturer's ingot analysis shall be considered the chemical analysis for strip, sheet, and plate, except for hydrogen and nitrogen, which shall be determined on the finished product.

7.2.1 The ingot shall be sampled in sufficient places along the side wall so that the top sample is within 5 in. [125 mm] of the top face. A minimum of three samples per ingot is required.

7.2.2 These samples shall be analyzed for the alloying and impurity elements given in Table 1.

7.2.3 Alternatively, the manufacturer may sample an intermediate or final size during processing with the same frequency and in the same positions relative to the ingot as specified in 7.2.1 to determine the composition, except for hydrogen and nitrogen, which shall be determined on the finished product.

### 7.3 Check Analysis:

7.3.1 Check analysis is an analysis made by the purchaser or the manufacturer of the metal after it has been processed into finished mill forms, and is either for the purpose of verifying the composition of a heat or lot or to determine variations in the composition within a heat or lot. Acceptance or rejection of a lot of material may be made by the purchaser on the basis of this check analysis. When requested by the purchaser and stated in the purchase order, a product check analysis for any elements listed in Table 1 shall be made on the finished product.

7.3.2 Check analysis limits shall be as specified in Table 2. These limits are the amounts an individual result for a given element may vary under or over the specified limits shown in Table 1.

TABLE 1 Chemical Requirements<sup>A</sup>

Element	Composition, %				
	Grades				
	R60700	R60702	R60704	R60705	R60706
Zirconium + hafnium, min	99.2	99.2	97.5	95.5	95.5
Hafnium, max	4.5	4.5	4.5	4.5	4.5
Iron + chromium	0.2 max	0.2 max	0.2 to 0.4	0.2 max	0.2 max
Tin	...	...	1.0 to 2.0	...	...
Hydrogen, max	0.005	0.005	0.005	0.005	0.005
Nitrogen, max	0.025	0.025	0.025	0.025	0.025
Carbon, max	0.05	0.05	0.05	0.05	0.05
Niobium	...	...	...	2.0 to 3.0	2.0 to 3.0
Oxygen, max	0.10	0.16	0.18	0.18	0.16

<sup>A</sup> By agreement between the purchaser and the manufacturer, analysis may be required and limits established for elements and compounds not specified in the table of chemical composition (see 7.1.1).

**TABLE 2 Permissible Variation in Check Analysis Between Different Laboratories**

Element	Permissible Variation in Product Analysis, %
Hydrogen	0.002
Nitrogen	0.01
Carbon	0.01
Hafnium	0.1
Iron + chromium	0.025
Tin	0.05
Niobium	0.05
Oxygen	0.02

7.3.3 Check analysis tolerances do not broaden the specified heat analysis requirements but cover variations between laboratories in the measurement of chemical content.

7.3.4 The manufacturer shall not ship material that is outside the limits specified in Table 1 for the applicable grade.

**8. Mechanical Properties**

8.1 The material, as represented by the test specimens, shall conform to the tensile properties prescribed in Table 3 for room temperature mechanical properties.

8.2 For strip and sheet, the bend test specimen shall stand being bent at ambient temperature through an angle of 105° without fracture in the outside of the bent portion. The bend shall be made around a mandrel having a radius equal to that shown in Table 3 for the applicable grade. Bend testing shall be performed in accordance with Test Methods E290.

**9. Condition and Finish**

9.1 Sheet, strip, or plate shall be furnished in one of the following conditions as designated on the purchase order:

Form	Condition
Strip	hot-rolled
	hot-rolled, annealed
	cold-rolled
	cold-rolled, annealed
	cold-rolled, annealed, followed by a final light cold-rolled pass, generally on polished rolls
Sheet	hot-rolled
	hot-rolled, annealed
	cold-rolled, annealed
	cold-rolled, annealed, followed by a final light cold-rolled pass, generally on polished rolls
	hot-rolled, annealed

**TABLE 3 Tensile Requirements**

	Grades				
	R60700	R60702	R60704	R60705	R60706
Tensile strength, min, ksi [MPa]	...	55 [380]	60 [415]	80 [550]	74 [510]
Yield strength, min, ksi [MPa]	...	30 [205]	35 [240]	55 [380]	50 [345]
Tensile strength, max, ksi [MPa]	55 [380]	...	...	...	...
Yield strength, max, ksi [MPa]	44 [305]	...	...	...	...
Elongation in 2 in. or 50 mm, min, % <sup>A</sup>	20	16	14	16	14
Bend test radius <sup>B</sup>	5T	5T	5T	3T	2.5T

<sup>A</sup> When a sub-size specimen is used, the gage length shall be as specified in Test Methods E8/E8M for that specimen.

<sup>B</sup> T equals the thickness of the bend test specimen. Bend tests are not applicable to material over 0.187 in. [4.8 mm] in thickness.

9.2 Hot-rolled sheet, strip, or plate shall be furnished with one of the following finishes as designated in the purchase order:

- 9.2.1 Not descaled,
- 9.2.2 Mechanically descaled,
- 9.2.3 Mechanically descaled and pickled,
- 9.2.4 As-ground.

9.3 Cold-rolled sheet or strip shall be furnished with one of the following finishes as designated in the purchase order:

- 9.3.1 Bright cold-rolled,
- 9.3.2 Ground 32 μin. [0.8 μm] rms or better, or
- 9.3.3 Pickled.

9.4 *Hot-Rolled Strip*—The following types of edges can be furnished on hot-rolled strip when specified in the purchase order:

- 9.4.1 Mill edge,
- 9.4.2 Split edge, or
- 9.4.3 Sheared edge.

9.5 *Cold-Rolled Strip*—A slit edge is normally furnished on cold-rolled strip. A machined edge is available for weld preparation when specified in the purchase order.

9.6 *Sheet and Plate*—Both hot- and cold-rolled sheet and plate are furnished with a sheared edge.

**10. Permissible Variations in Dimensions and Weights**

10.1 *Thickness*—The variations in thickness of strip, sheet, and plate are given in the following tables:

- 10.1.1 Hot-rolled strip, Table 4.
- 10.1.2 Cold-rolled strip, Table 5.
- 10.1.3 Hot- and cold-rolled sheet, Table 6.
- 10.1.4 Plate, Table 7.

10.2 *Width*—The variations in width are given in the following tables:

- 10.2.1 Hot-rolled strip, Table 8.
- 10.2.2 Cold-rolled strip, Table 9.
- 10.2.3 Hot- and cold-rolled sheet, Table 10.
- 10.2.4 Plate, Table 11.

10.3 *Length*—The variations in length are given in the following tables:

- 10.3.1 Hot- and cold-rolled strip, Table 12.
- 10.3.2 Hot- and cold-rolled sheet, Table 13.
- 10.3.3 Plate, Table 11.

10.4 *Crown Tolerances*—The variations in crown tolerances are given in the following tables:

- 10.4.1 Hot-rolled strip, Table 14.

**TABLE 4 Permissible Variations in Thickness of Hot-Rolled Zirconium Strip<sup>A</sup>**

Specified Width, in. [mm]	Variation from Specified Thickness for Widths Given, Over and Under, in [mm]	
	0.083–0.118 [2.1–3.0]	Over 0.118–0.188 [3.0–4.78]
To 3½ [90], incl	0.005 [0.13]	0.006 [0.15]
Over 3½ [90] –6 [150], incl	0.006 [0.15]	0.007 [0.18]

<sup>A</sup> Thickness measurements are taken at least ¼ in. [10 mm] from edge.

10.4.2 Cold-rolled strip, Table 15.

10.4.3 Hot-rolled sheet, Table 16.

10.4.4 Cold-rolled sheet, Table 17.

10.5 *Camber Tolerances*—The variations in camber tolerances are given in the following tables.

10.5.1 Hot- and cold-rolled strip, Table 18.

10.5.2 Hot- and cold-rolled sheet, Table 19.

10.5.3 Plate, Table 20.

10.6 *Diameter*—The variation in diameter tolerance for circular plates is given in Table 21.

10.7 *Flatness*—The permissible variation from a flat surface for plate is given in Table 22.

10.8 *Weight*—The actual shipping weight of any one item of an ordered thickness and width in any finish may exceed estimated weight by as much as 10 %.

## 11. Workmanship and Appearance

11.1 Cracks, seams, slivers, blisters, burrs, and other injurious imperfections shall not exceed standards of acceptability agreed upon by the manufacturer and the purchaser.

11.2 The finished strip, sheet, or plate shall be visibly free of oxide, grease, oil, residual lubricants, and other extraneous materials.

11.3 Methods of testing for these defects and standards of acceptability shall be as agreed upon between the manufacturer and the purchaser.

11.4 The manufacturer shall be permitted to remove surface imperfections provided such removal does not reduce the dimensions below the minimum permitted by the tolerances for that dimension.

## 12. Significance of Numerical Limits

12.1 For the purpose of determining compliance with the specified limits for requirements of the properties listed in the following table, an observed value or a calculated value shall be rounded as indicated in accordance with the rounding methods of Practice E29.

Property	Rounded Unit for Observed or Calculated Value
Chemical composition and tolerances (when expressed as decimals)	nearest unit in the last right-hand place of figures of the specified limit
Tensile strength and yield strength	nearest 1000 psi [10 MPa]
Elongation	nearest 1 %

## 13. Number of Tests and Retests

13.1 One longitudinal tension shall be made from each lot (see 14.2).

13.2 One chemistry test for hydrogen and nitrogen content shall be made from each lot of finished product (see 14.1).

13.3 Two bend tests, one in the longitudinal and one in the transverse direction, shall be made from each lot (see 8.2).

### 13.4 Retests:

13.4.1 If any sample or specimen exhibits obvious surface contamination or improper preparation disqualifying it as a truly representative sample, it shall be discarded and a new sample or specimen substituted.

13.4.2 If the results of any chemical or mechanical property test lot are not in conformance with the requirements of this specification, the lot may be retested at the option of the manufacturer. Retests shall be made on double the original number of samples from the same lot. Both retest values shall conform to the requirements specified. These acceptable retest values will become the test values for certification.

13.4.3 If the results for the retest fail to conform to the specification, the material will be rejected in accordance with Section 16. Retesting after failure of initial retests may be done only with the approval of the purchaser.

## 14. Sampling and Test Methods

### 14.1 Sampling:

14.1.1 Samples for chemical and mechanical testing shall be taken from the finished material after all metallurgical processing to determine conformity to this specification. The samples may be taken prior to final inspection and minor surface conditioning by abrasion and pickling shall be representative of the finished product.

14.1.2 Care shall be exercised to ensure that the sample selected for testing is representative of the material and that it is not contaminated by the sampling procedure. If there is any question relating to the sampling technique or the analyses, the methods of sampling and analysis shall be as agreed upon between the purchaser and the manufacturer.

14.1.3 The utmost care must be used in sampling reactive metals for chemical analysis because of their great affinity for elements such as oxygen, nitrogen, and hydrogen. Therefore, in cutting samples for analysis, the operation should be carried out in a dust-free atmosphere. Chips should be collected from clean metal and tools should be clean and sharp. Samples for analysis should be stored in suitable containers.

### 14.2 Test Methods:

#### 14.2.1 Chemistry:

14.2.1.1 Analyses shall be made using the manufacturer's standard methods.

14.2.1.2 The chemical composition enumerated in this specification shall in case of disagreement, be measured by methods mutually agreed upon by the manufacturer and the purchaser.

#### 14.2.2 Tension Tests:

14.2.2.1 The room temperature tensile tests shall be conducted in accordance with Test Methods E8/E8M. The yield strength shall be determined by the offset (0.2 %) method. The

**TABLE 5 Permissible Variations in Thickness of Cold-Rolled Zirconium Strip**

NOTE 1—For thickness under 0.010 in. [0.25 mm] in width to 6 in. [150 mm] a tolerance of ±10 % of the thickness shall apply.

NOTE 2—Thickness measurements shall be taken 3/8 in. [10 mm] in from edge of the strip, except on widths less than 1 in. [2.5 mm] where the tolerances are applicable for measurements at all locations.

Specified Thickness, in. [mm]	Permissible Variations in Thickness, for Widths Given, ± in. [mm]		
	3/16 [4.8] to 1 [25], excl	1 [25] to 3 [75], excl	3 [75] to 6 in. [150], excl
0.188–0.160 [4.78–4.06], incl	0.002 [0.05]	0.003 [0.08]	0.004 [0.10]
0.160–0.100 [4.05–2.52], incl	0.002 [0.05]	0.002 [0.05]	0.003 [0.08]
0.099–0.069 [2.51–1.75], incl	0.002 [0.05]	0.002 [0.05]	0.003 [0.08]
0.068–0.050 [1.74–1.27], incl	0.002 [0.05]	0.002 [0.05]	0.003 [0.08]
0.049–0.040 [1.26–1.01], incl	0.002 [0.05]	0.002 [0.05]	0.0025 [0.07]
0.039–0.035 [0.99–0.90], incl	0.002 [0.05]	0.002 [0.05]	0.0025 [0.06]
0.034–0.029 [0.87–0.73], incl	0.0015 [0.04]	0.0015 [0.04]	0.002 [0.05]
0.028–0.026 [0.72–0.66], incl	0.001 [0.025]	0.0015 [0.04]	0.0015 [0.04]
0.025–0.020 [0.65–0.51], incl	0.001 [0.025]	0.001 [0.025]	0.0015 [0.04]
0.019 [0.50] and under	0.001 [0.025]	0.001 [0.025]	0.001 [0.025]

**TABLE 6 Permissible Variations in Thickness of Hot- and Cold-Rolled Zirconium Sheet<sup>A</sup>**

Specified Thickness, in. [mm]	Hot-Rolled	Cold-Rolled
	Permissible Variations in Thickness, ± in. [mm]	Permissible Variations in Thickness, ± in. [mm]
0.146 to 0.188 [3.70 to 4.76], excl	0.014 [0.35]	0.007 [0.18]
0.131 to 0.145 [3.32 to 3.69]	0.012 [0.30]	0.006 [0.15]
0.115 to 0.130 [2.92 to 3.31]	0.010 [0.25]	0.005 [0.13]
0.099 to 0.114 [2.50 to 2.91]	0.009 [0.23]	0.0045 [0.11]
0.084 to 0.098 [2.13 to 2.49]	0.008 [0.20]	0.004 [0.10]
0.073 to 0.083 [1.85 to 2.12]	0.007 [0.18]	0.0035 [0.09]
0.059 to 0.072 [1.49 to 1.84]	0.006 [0.15]	0.003 [0.08]
0.041 to 0.058 [1.04 to 1.48]	0.005 [0.13]	0.0025 [0.07]
0.027 to 0.040 [0.68 to 1.03]	0.004 [0.10]	0.002 [0.05]
0.017 to 0.026 [0.43 to 0.67]	0.003 [0.08]	0.0015 [0.4]
0.008 to 0.016 [0.20 to 0.42]	0.002 [0.05]	0.001 [0.03]
0.006 to 0.007 [0.14 to 0.19]	0.0015 [0.04]	0.0008 [0.02]
0.005 [0.13] or less	0.001 [0.025]	0.0005 [0.01]

<sup>A</sup> Thickness measurements are taken at least 3/8 in. [10 mm] in from edge. Tolerances do not include crown.

**TABLE 7 Permissible Variations in Thickness of Zirconium Plate**

Specified Thickness, in. [mm]	Width, in. [mm] <sup>A</sup>			
	To 84 [2130], incl	Over 84 [2130] to 120 [3050], incl	Over 120 [3050] to 144 [3660], incl	Over 144 [3660]
	Tolerances Over Specified Thickness, in. [mm] <sup>B</sup>			
0.125 [3.2] to 0.375 [9.5], excl	0.045 [1.14]	0.050 [1.27]	...	...
0.375 [9.5] to 0.75 [19], excl	0.055 [1.40]	0.060 [1.52]	0.075 [1.90]	0.090 [2.29]
0.75 [19] to 1.0 [25], excl	0.060 [1.52]	0.065 [1.65]	0.085 [2.16]	0.100 [2.54]
1.0 [25] to 2.0 [50], excl	0.070 [1.78]	0.075 [1.90]	0.095 [2.41]	0.115 [2.92]
2.0 [50] to 3.0 [75], excl	0.125 [3.18]	0.150 [3.81]	0.175 [4.44]	0.200 [5.08]
3.0 [75] to 4.0 [100], excl	0.175 [4.44]	0.210 [5.33]	0.245 [6.22]	0.280 [7.11]
4.0 [100] to 6.0 [150], excl	0.250 [6.35]	0.300 [7.62]	0.350 [8.89]	0.400 [10.16]
6.0 [150] to 8.0 [200], excl	0.350 [8.89]	0.420 [10.67]	0.490 [12.45]	0.560 [14.22]
8.0 [200] to 10.0 [250], incl	0.450 [11.43]	0.540 [13.72]	0.630 [16.00]	...

<sup>A</sup> Thickness is measured along the longitudinal edges of the plate at least 3/8 in. [10 mm], but not more than 3 in. [75 mm] from the edge.

<sup>B</sup> For circles, the over thickness tolerances in this table apply to the diameter of the circle corresponding to the width ranges shown. For plates of irregular shape, the over thickness tolerances apply to the greatest width corresponding to the width ranges shown. For plates up to 10 in. [250 mm], incl. in thickness, the tolerance under the specified thickness is 0.01 in. [0.25mm].

**TABLE 8 Permissible Variations in Width of Hot-Rolled Zirconium Strip**

Specified Width, in. [mm]	Permissible Variation in Width, in. [mm]					
	Mill Edge		Slit Edge		Sheared Edge	
	+	-	+	-	+	-
3 1/2 [90] and under	1/8 [3.2]	0 [0]	1/32 [0.8]	1/32 [0.8]	1/16 [1.6]	1/16 [1.6]
Over 3 1/2 [90] – 6 [150], incl	3/16 [4.8]	1/8 [3.2]	1/32 [0.8]	1/32 [0.8]	...	0 [0]

TABLE 9 Permissible Variations in Width of Cold-Rolled Zirconium Strip (Slit Edge)

Specified Thickness, in. [mm]	Permissible Variations in Thickness, plus and minus, for Widths Given, in. [mm]	
	Under ½ [12]	½ to 6 [12 to 152], incl
0.188 to 0.161 [4.76 to 4.08], incl	...	0.016 [0.41]
0.160 to 0.100 [4.07 to 2.53], incl	0.010 [0.25]	0.010 [0.25]
0.099 to 0.069 [2.52 to 1.74], incl	0.008 [0.20]	0.008 [0.20]
0.068 [1.73] and under	0.005 [0.13]	0.005 [0.13]

TABLE 10 Permissible Variations in Width of Hot- and Cold-Rolled Zirconium Sheet

Specified Width, in. [mm] for Thickness Under ¾ in. [4.8 mm]	Permissible Variations in Width, in. [mm]
6–24 [150–600], excl	+¼, –0 [+3.2, –0]
24–48 [600–1200], excl	+¼, –0 [+3.2, –0]
48 and over [1200]	+¾, –0 [+4.8, –0]

tensile properties shall be determined using a strain rate of 0.003 to 0.007 in./in./min [mm/mm/min] through the yield strength. After the yield strength has been exceeded, the crosshead speed can be increased to approximately 0.05 in./in./min [mm/mm/min] to produce failure in approximately one additional minute.

14.2.2.2 Small size, 1-in. [25-mm] gage length specimens, proportional to the standard specimen, can be used.

#### 14.2.3 Flatness:

14.2.3.1 Flatness shall be determined in accordance with Eq 1 (see Fig. 1):

$$\text{Flatness, \%} = (H/L) \times 100 \quad (1)$$

where:

- $H$  = maximum vertical distance between a flat reference surface and the lower surface of the sheet, and  
 $L$  = minimum horizontal distance between the highest point on the sheet and the point of contact with a flat reference surface. (Fig. 1 is included to illustrate the method for taking measurements for calculation of sheet flatness; however, a value of  $H$  less than 1/32 in. [0.8 mm] shall not be cause for rejection.)

### 15. Inspection

15.1 The manufacturer shall inspect the material covered by this specification prior to shipment and, on request, shall furnish the purchaser with certificates of test. If so specified in the purchase order, the purchaser or his representative may witness the testing and inspection of the material at the place of manufacture. In such cases the purchaser shall state in his purchase order which tests he desires to witness. The manufacturer shall give ample notice to the purchaser as to the time and place of the designated tests. If the purchaser's representative does not present himself at the time agreed upon for the testing, the manufacturer shall consider the requirement for purchaser's inspection at the place of manufacture to be waived.

15.2 The manufacturer shall afford the inspector representing the purchaser, without charge, all reasonable facilities to satisfy him that the material is being furnished in accordance

with this specification. This inspection shall be so conducted as to not interfere unnecessarily with the operation of the works.

### 16. Rejection and Referee

16.1 Material not conforming to the specification or to authorized modifications shall be subject to rejection by the purchaser.

16.2 Unless otherwise specified, rejected material may be returned to the manufacturer at the manufacturer's expense, unless the purchaser receives, within three weeks of the notice of rejection, other instructions for disposition.

16.3 In the event of disagreement between the manufacturer and the purchaser on the conformance of the material to the requirements of this specification or any special test specified by the purchaser, a mutually acceptable referee shall perform the tests in question. The results of the referee's testing shall be used in determining conformance of the material to this specification.

### 17. Certification

17.1 A producer or supplier shall furnish the purchaser with a certificate that the material was manufactured, sampled, tested, and inspected in accordance with this specification and has been found to meet the requirements. The certificate shall include a report of the test results.

### 18. Product Marking

18.1 *Identification*—Unless otherwise specified, each plate, sheet, and strip shall be marked in the respective location indicated below, with the number of this specification, heat number, manufacturer's identification, and the nominal thickness. The characters shall be not less than 3/8 in. [9.52 mm] in height, shall be applied using a suitable marking fluid, and shall be capable of being removed with a hot alkaline cleaning solution without rubbing. The marking shall have no deleterious effect on the material or its performance. The characters shall be sufficiently stable to withstand ordinary handling.

18.1.1 Plate, flat sheet, and flat strip over 6 in. [150 mm] in width shall be marked in lengthwise rows of characters recurring at intervals not greater than 3 in. [75 mm], the rows being spaced not more than 1 in. [40 mm] apart and alternatively staggered. Heat numbers shall occur at least three times across the width of the material and at intervals not greater than 2 ft [0.6 m] along the length. As an option, when permitted by the purchaser, each plate, sheet, or cut length strip may be marked in at least one corner with the number of this specification, heat number, manufacturer's identification, and the nominal thickness in inches or millimetres as required.

**TABLE 11 Permissible Variations in Width and Length of Rectangular, Sheared Zirconium Plate**

NOTE 1—The permissible variation under the specified width and length is ¼ in. [6.4 mm]

NOTE 2—Rectangular plates over 1 in. [25 mm] in thickness are not commonly sheared, and are machined or otherwise cut to length and width or produced in the size as-rolled, uncropped.

Specified Length, in. [m]	Specified Width, in. [m]	Permissible Variations Over Specified Dimension, for Thickness Given, in. [mm]					
		Under ⅜ in. [9.5 mm]		⅜–⅝ in. [9.5–16 mm], excl		⅝ in. [16 mm] and Over	
		Width	Length	Width	Length	Width	Length
Under 120 [3.0]	Under 60 [1.5]	⅜ [9.5]	½ [13]	⅞ [11]	⅝ [16]	½ [13]	¾ [20]
	60–84 [1.5–2.1], excl	⅞ [11]	⅝ [16]	½ [13]	⅞ [18]	⅝ [16]	⅞ [22]
	84–108 [2.1–2.74], excl	½ [13]	¾ [20]	⅝ [16]	⅞ [22]	¾ [20]	1 [25]
	108 [2.74] or over	⅝ [16]	⅞ [22]	¾ [20]	1 [25]	⅞ [22]	1⅞ [29]
120–240 [3.0–6.0], excl	Under 60 [1.5]	⅜ [9.5]	⅝ [16]	½ [13]	⅞ [22]	⅝ [16]	1 [25]
	60–84 [1.5–2.1], excl	½ [13]	¾ [20]	⅝ [16]	⅞ [22]	¾ [20]	1 [25]
	84–108 [2.1–2.74], excl	⅞ [14]	⅞ [22]	⅞ [18]	1⅞ [24]	1⅞ [21]	1⅞ [29]
	108 [2.74] or over	⅝ [16]	1 [25]	¾ [20]	1⅞ [29]	⅞ [22]	1⅞ [32]
240–360 [6.0–9.0], excl	Under 60 [1.5]	⅜ [9.5]	1 [25]	½ [13]	1⅞ [29]	⅝ [16]	1¼ [32]
	60–84 [1.5–2.1] excl	½ [13]	1 [25]	⅝ [16]	1⅞ [29]	¾ [20]	1¼ [32]
	84–108 [2.1–2.74], excl	⅞ [14]	1 [25]	1⅞ [18]	1⅞ [29]	⅞ [22]	1⅞ [35]
	108 [2.74] or over	1⅞ [18]	1⅞ [29]	⅞ [22]	1¼ [32]	1 [25]	1⅞ [35]
360–480 [9.0–12.0], excl	Under 60 [1.5]	⅞ [11]	1⅞ [29]	½ [13]	1⅞ [32]	⅝ [16]	1½ [38]
	60–84 [1.5–2.1], excl	½ [13]	1¼ [32]	⅝ [16]	1⅞ [35]	¾ [20]	1½ [38]
	84–108 [2.1–2.74], excl	⅞ [14]	1¼ [32]	¾ [20]	1⅞ [35]	⅞ [22]	1½ [38]
	108 [2.74] or over	¾ [20]	1⅞ [35]	⅞ [22]	1½ [38]	1 [25]	1⅞ [41]
480–600 [12.0–15.0], excl	Under 60 [1.5]	⅞ [11]	1¼ [32]	½ [13]	1½ [38]	⅝ [16]	1⅞ [41]
	60–84 [1.5–2.1], excl	½ [13]	1⅞ [35]	⅝ [16]	1½ [38]	¾ [20]	1⅞ [41]
	84–108 [2.1–2.74], excl	⅝ [16]	1⅞ [35]	¾ [20]	1½ [38]	⅞ [22]	1⅞ [41]
	108 [2.74] or over	¾ [20]	1½ [38]	⅞ [22]	1⅞ [41]	1 [25]	1⅞ [45]
600 [15.0] or over	Under 60 [1.5]	½ [13]	1¾ [45]	⅝ [16]	1⅞ [48]	⅝ [16]	1⅞ [48]
	60–84 [1.5–2.1], excl	⅝ [16]	1¾ [45]	¾ [20]	1⅞ [48]	⅞ [22]	1⅞ [48]
	84–108 [2.1–2.74], excl	⅝ [16]	1¾ [45]	¾ [20]	1⅞ [48]	⅞ [22]	1⅞ [48]
	108 [2.74] or over	⅞ [22]	1¾ [45]	1 [25]	2 [50]	1⅞ [29]	2¼ [57]

**TABLE 12 Permissible Variations in Length of Hot- and Cold-Rolled Zirconium Strip**

Specified Length, ft [m]	Permissible Variations in Length, in. [mm]
To 5 [1.5], incl	+⅜, – 0 [+ 9.5, 0]
Over 5–10 [1.5–3], incl	+½, – 0 [+13, –0]
Over 10–20 [3–6.1], incl	+⅝, – 0 [+16, –0]

**TABLE 13 Permissible Variations in Length of Hot- and Cold-Rolled Zirconium Sheet**

Specified Length, ft [m]	Permissible Variations in Length, in. [mm]
To 5 [1.5], incl	+⅜, – 0 [+9.5, –0]
Over 5 [1.5]–10 [3], incl	+½, – 0 [+13, –0]
Over 10 [3]–15 [4.6], incl	+1, –0 [+25, –0]

**TABLE 14 Crown Tolerances for Hot-Rolled Zirconium Strip**

Specified Width, in. [mm]	Permissible Variation in Thickness from Edge to Center of Strip, for Widths Given, in. [mm]
To 3½ [90], incl	0.003 [0.08]
Over 3½–6 [90–150], incl	0.004 [0.10]

18.1.2 Flat strip 6 in. [150 mm] and under in width shall be marked near one end.

**TABLE 15 Crown Tolerances for Cold-Rolled Zirconium Strip**

Specified Thickness, in. [mm]	Tolerance by which the Thickness at Middle of Strip may be Greater than at the Edges, for Width to 6 in. [150 mm], in. [mm]
0.005 [13]–0.010 [25], incl	0.0008 [0.02]
Over 0.010 [25]–0.025 [64], incl	0.001 [0.025]
Over 0.025 [64]–0.065 [1.65], incl	0.0015 [0.04]
Over 0.065 [1.65]–0.188 [4.8], excl	0.002 [0.05]

18.1.3 Coiled sheet and strip shall be marked near the outside end of the coil.

**19. Packaging and Package Marking**

19.1 Unless otherwise specified, material purchased under this specification may be packaged for shipment either by boxing, crating, single boarding, burlapping, or with no protection in accordance with the manufacturer’s standard practice.

19.2 All material shall be packaged in such a manner as to assure safe delivery to its destination when properly transported by any common carrier.

19.3 The package shall be so marked as to indicate the nature of any special handling required.

19.4 Each bundle, box, or coil shall be legibly and conspicuously marked or tagged with the following information:

19.4.1 Purchase order or contract number,

**TABLE 16 Crown Tolerances for Hot-Rolled Zirconium Sheet**

Specified Width, in. [mm]	Permissible Variation in Thickness from Edge to Center of Strip, for Widths Given, in. [mm]
6–12 [150–300], incl	0.004 [0.10]
Over 12–18 [300–460], incl	0.006 [0.15]
Over 18–24 [460–500], excl	0.008 [0.20]

**TABLE 17 Crown Tolerances for Cold-Rolled Zirconium Sheet**

Specified Thickness, in. [mm]	Tolerance by Which the Thickness at Middle of Strip may be Greater than at the Edges, for Widths Given, in. [mm]	
	6 [150] to 12 [300], incl	Over 12 [300] to 24 [600], incl
0.005 [.13]–0.010 [.25], incl	0.001 [.025]	0.0015 [.04]
Over 0.010 [.25]–0.025 [.64], incl	0.0015 [.04]	0.002 [.05]
Over 0.025 [.64]–0.065 [1.65], incl	0.002 [.05]	0.0025 [.06]
Over 0.065 [1.65]– $\frac{3}{16}$ [4.8], excl	0.0025 [.06]	0.003 [.08]

**TABLE 18 Camber Tolerance for Hot- and Cold-Rolled Zirconium Strip<sup>A</sup>**

Specified Width, in. [mm]	Tolerance, per Unit Length of any 8 ft [2.4 m], in. [mm]
To 1½ [38], incl	$\frac{1}{8}$ [3.2]
Over 1½ –6 [38–150], incl	$\frac{3}{32}$ [2.4]

<sup>A</sup> Camber is the greatest deviation of a side edge from a straight line, the measurement being taken on the concave side with a straightedge.

**TABLE 19 Camber Tolerances for Hot- and Cold-Rolled Zirconium Sheet<sup>A</sup>**

Specified Width, in. [mm]	Tolerance per Unit Length of any 8 ft [24 m], in. [mm]
6–36 [600–900], incl	$\frac{1}{8}$ [3.2]
Over 36 [900]	$\frac{3}{32}$ [2.4]

<sup>A</sup> Camber is the greatest deviation of a side edge from a straight line, the measurement being taken on the concave side with a straightedge.

**TABLE 20 Camber Tolerances for Zirconium Plates<sup>A</sup>**

Tolerance:	$\frac{1}{8}$ in. [3.2 mm] × (number of feet of length/5) (number of metres/1.5)
------------	---

<sup>A</sup> Camber is the greatest deviation of a side edge from a straight line. The measurement is taken by placing a straightedge on the concave side and measuring the greatest distance between the plate edge and the straightedge.

19.4.2 Name of material,

19.4.3 Grade,

19.4.4 Size,

19.4.5 Lot, heat, or ingot number,

19.4.6 Condition (see Section 9),

19.4.7 Gross, net and tare weights, and

19.4.8 Standard specification number.

## 20. Keywords

20.1 plate; sheet; strip; zirconium; zirconium alloy

**TABLE 21 Diameter Tolerances for Circular Zirconium Plates**

Specified Diameter, in. [m]	Tolerance Over Specified Diameter for Given Diameter and Thickness (No Tolerance Under), in. [mm]		
	To 3/8 [9.5], incl, in Thickness	3/8 to 5/8 [9.5–16] excl, in Thickness	5/8 [16] and Over in Thickness <sup>A</sup>
To 60 [1.5], excl	1/4 [6.4]	3/8 [9.5]	1/2 [13]
60–84 [1.5–2.1], incl	5/16 [8.0]	7/16 [11]	9/16 [14]
84–108 [2.1–2.8], excl	3/8 [9.5]	1/2 [13]	5/8 [16]
108–130 [2.8–3.3], incl	7/16 [11]	9/16 [14]	11/16 [17.5]

<sup>A</sup> Circular plates over 5/8 in. [16 mm] in thickness are not commonly sheared and are machined or otherwise cut.

**TABLE 22 Permissible Variations From a Flat Surface for Annealed Zirconium Plate—inch [mm]**

NOTE 1—Variations in flatness apply to plates up to 15 ft [4.6 m] in length, or to any 15 ft [4.6 m] of longer plates.

NOTE 2—If the longer dimension is under 36 in. [1 m], the variation is not greater than 1/4 in. [6.4 mm].

NOTE 3—The shorter dimension specified is considered the width and the variation in flatness across the width does not exceed the tabular amount for that width dimension.

NOTE 4—The maximum deviation from a flat surface is measured in accordance with 14.2.3 and Fig. 1.

Specified Thickness, in. [mm]	Permissible Variations in Flatness, for Widths Given, Plus and Minus, in. [mm]								
	48 in. [1.2 m] or Under	48 [1.2 m]–60 [1.5 m], excl	60 [1.5]–72 [1.8 m], excl	72 [1.8]–84 [2.1 m], excl	84 [2.1]–96 [2.4 m], excl	96 [2.4 m]–108 [2.74 m], excl	108 [2.74]–120 [3.05 m], excl	120 [3.05]–144 [3.7 m], excl	144 [3.7 m] and Over
1/8 [3.2]–1/4 [6.4], excl	3/4 [20]	1 1/16 [27]	1 1/4 [32]	1 3/8 [35]	1 5/8 [41]	1 7/8 [41]	...	...	...
1/4 [6.4]–3/8 [9.5], excl	1 1/16 [17.5]	3/4 [20]	1 1/16 [24]	1 1/8 [28.6]	1 3/8 [35]	1 7/16 [36.5]	1 9/16 [40]	1 7/8 [48]	...
3/8 [9.5]–1/2 [13], excl	1/2 [13]	9/16 [14]	1 1/16 [17.5]	3/4 [20]	1 5/16 [24]	1 1/8 [28.6]	1 1/4 [32]	1 7/16 [36.5]	1 3/4 [45]
1/2 [13]–3/4 [20], excl	1/2 [13]	9/16 [14]	5/8 [16]	5/8 [16]	1 3/16 [20.6]	1 1/8 [28.6]	1 1/8 [28.6]	1 1/8 [28.6]	1 3/8 [35]
3/4 [20]–1 [25], excl	1/2 [13]	9/16 [14]	5/8 [16]	5/8 [16]	3/4 [20]	1 3/16 [30]	1 5/16 [24]	1 [25]	1 1/8 [28.6]
1 [25]–1 1/2 [38], excl	1/2 [13]	9/16 [14]	9/16 [14]	9/16 [14]	1 1/16 [17.5]	1 1/16 [17.5]	1 1/16 [17.5]	3/4 [20]	1 [25]
1 1/2 [39]–4 [100], excl	3/16 [4.8]	5/16 [8]	3/8 [9.5]	7/16 [11]	1/2 [13]	9/16 [14]	5/8 [16]	3/4 [20]	7/8 [22]
4 [100]–6 [150], excl	1/4 [6.4]	3/8 [9.5]	1/2 [13]	9/16 [14]	5/8 [16]	3/4 [20]	7/8 [22]	1 [25]	1 1/8 [28.6]

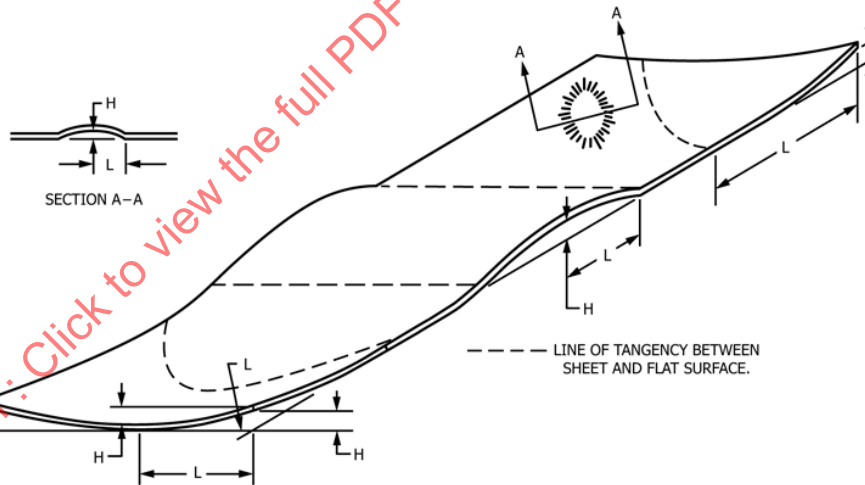

Flatness Deviation, % = (H/L) × 100.

H = maximum distance between flat surface and lower surface of sheet.

L = minimum distance between highest point on sheet and point of contact with flat surface.

## SUPPLEMENTARY REQUIREMENTS

**S.1 Additional Requirements for Material to be Used for Explosion Cladding**

S1.1 These requirements apply exclusively for sheet and plate to be used for explosion cladding.

S1.2 These requirements apply only to Grades R60700 and R60702 and only in thicknesses ranging from 0.078 in. [2 mm] to 0.78 in. [20 mm] inclusive.

S1.3 Additional flatness requirements:

S1.3.1 The permissible variation in flatness for zirconium material grades R60700 and R60702 for explosion cladding applications shall be  $\frac{1}{2}$  that of the limits in Table 22. Localized flatness variations shall not exceed 0.12 in. [3 mm] in 39 in. [1 m], as measured using a straight edge placed (balanced) at any location on the plate surface.

ASMENORMDOC.COM : Click to view the full PDF of ASME BPVC.II.B (ASME BPVC Section II Part B) 2025

ASMENORMDOC.COM : Click to view the full PDF of ASME BPVC.II.B (ASME BPVC Section II part B) 2025

INTENTIONALLY LEFT BLANK

## SPECIFICATION FOR NICKEL ALLOY FORGINGS



**SB-564**



(25)

(Identical with ASTM Specification B564-22 except that certification and test reports have been made mandatory.)

*ASME SB-564 replaces paras. 3.1.5 and 14.1 of ASTM B564 with the following:*

3.1.5 DELETED

14.1 A manufacturer's certification shall be furnished to the purchaser stating that material has been manufactured, tested, and inspected in accordance with this specification, and that the test results on representative samples meet specification requirements. A report of the test results shall be furnished.



Designation: B564 – 22

## Standard Specification for Nickel Alloy Forgings<sup>1</sup>

This standard is issued under the fixed designation B564; the number immediately following the designation indicates the year of original adoption or, in the case of revision, the year of last revision. A number in parentheses indicates the year of last reappraisal. A superscript epsilon ( $\epsilon$ ) indicates an editorial change since the last revision or reappraisal.

*This standard has been approved for use by agencies of the U.S. Department of Defense.*

### 1. Scope\*

1.1 This specification<sup>2</sup> covers forgings of:

Alloy Type	UNS Number(s)
Fe-Ni-Cr-Mo-N	N08367
Low-carbon Cr-Ni-Fe-N	R20033
Low-carbon Ni-Cr-Mo	N06035, N06058, N06059, N06044
Low-carbon Ni-Cr-Mo-Cu	N06200
Low-carbon Ni-Cr-Mo-W	N06686
Low-carbon Ni-Fe-Cr-Mo-Cu	N08031, N08034
Low-carbon Ni-Mo-Cr	N10276, N06022, N10362
Low-carbon Ni-Mo-Cr-Ta	N06210
Ni	N02200
Ni-Co-Cr-Si	N12160
Ni-Cr-Al	N06699
Ni-Cr-Co-Mo	N06617
Ni-Cr-Fe	N06600, N06603, N06690
Ni-Cr-Fe-Al	N06025
Ni-Cr-Fe-Si	N06045
Ni-Cr-Mo-Nb	N06625
Ni-Cr-Mo-Si	N06219
Ni-Cr-Mo-W	N06110
Ni-Cr-W-Mo	N06230
Ni-Cu	N04400
Ni-Fe-Cr	N08120, N08800, N08810, N08811
Ni-Fe-Cr-Mo-Cu	N08825, N08827
Ni-Fe-Cr-W	N06674
Ni-Mo	N10665, N10675, N10629
Ni-Mo-Cr-Fe	N10242, N10624

1.1.1 The nickel-iron-chromium alloys are UNS N08120, UNS N08800, UNS N08810, and UNS N08811. Alloy UNS N08800 is normally employed in service temperatures up to and including 1100 °F (593 °C). Alloys UNS N08810, N08120, and UNS N08811 are normally employed in service temperatures above 1100 °F (593 °C) where resistance to creep and rupture is required, and are annealed to develop controlled grain size for optimum properties in this temperature range.

1.1.2 Nickel-iron-chromium-tungsten alloy UNS N06674 is normally employed in service temperatures above 1100 °F (593 °C) where resistance to creep and rupture is required, and is annealed to develop optimum properties in this temperature range.

1.1.3 Nickel-chromium-molybdenum-columbium (UNS N06625) products are furnished in two grades of different heat-treated conditions:

1.1.3.1 *Grade 1 (Annealed)*—Material is normally employed in service temperatures up to 1100 °F (593 °C).

1.1.3.2 *Grade 2 (Solution annealed)*—Material is normally employed in service temperatures above 1100 °F (593 °C) where resistance to creep and rupture are required.

NOTE 1—Hot-working or reannealing may change properties significantly, depending on working history and temperatures.

1.2 The values stated in inch-pound units are to be regarded as standard. The values given in parentheses are mathematical conversions to SI units that are provided for information only and are not considered standard.

1.3 *This standard does not purport to address all of the safety concerns, if any, associated with its use. It is the responsibility of the user of this standard to become familiar with all hazards including those identified in the appropriate Safety Data Sheet (SDS) for this product/material as provided by the manufacturer, to establish appropriate safety, health, and environmental practices, and determine the applicability of regulatory limitations prior to use.*

1.4 *This international standard was developed in accordance with internationally recognized principles on standardization established in the Decision on Principles for the Development of International Standards, Guides and Recommendations issued by the World Trade Organization Technical Barriers to Trade (TBT) Committee.*

### 2. Referenced Documents

2.1 *ASTM Standards:*<sup>3</sup>

B880 Specification for General Requirements for Chemical Check Analysis Limits for Nickel, Nickel Alloys and Cobalt Alloys

E8/E8M Test Methods for Tension Testing of Metallic Materials

E29 Practice for Using Significant Digits in Test Data to

<sup>1</sup> This specification is under the jurisdiction of ASTM Committee B02 on Nonferrous Metals and Alloys and is the direct responsibility of Subcommittee B02.07 on Refined Nickel and Cobalt and Their Alloys.

Current edition approved April 1, 2022. Published April 2022. Originally approved in 1972. Last previous edition approved in 2019 as B564 – 19. DOI: 10.1520/B0564-22.

<sup>2</sup> For ASME Boiler and Pressure Vessel Code applications see related Specification SB-564 in Section II of that Code.

<sup>3</sup> For referenced ASTM standards, visit the ASTM website, www.astm.org, or contact ASTM Customer Service at service@astm.org. For *Annual Book of ASTM Standards* volume information, refer to the standard's Document Summary page on the ASTM website.

Determine Conformance with Specifications  
 E76 Test Methods for Chemical Analysis of Nickel-Copper Alloys (Withdrawn 2003)<sup>4</sup>  
 E112 Test Methods for Determining Average Grain Size  
 E350 Test Methods for Chemical Analysis of Carbon Steel, Low-Alloy Steel, Silicon Electrical Steel, Ingot Iron, and Wrought Iron  
 E1473 Test Methods for Chemical Analysis of Nickel, Cobalt and High-Temperature Alloys  
 2.2 *Military Standards*:<sup>5</sup>  
 MIL-STD-129 Marking for Shipment and Storage  
 MIL-STD-271 Nondestructive Testing Requirements for Metals

### 3. Ordering Information

3.1 It is the responsibility of the purchaser to specify all requirements that are necessary for material ordered under this specification. Examples of such requirements include, but are not limited to, the following:

- 3.1.1 Alloy (Table 1).
- 3.1.2 Condition (Table 2).
  - 3.1.2.1 Unless otherwise specified, UNS N06625 Grade 1 will be supplied.
- 3.1.3 Quantity (mass or number of pieces).
- 3.1.4 Forging, sketch or drawing.
- 3.1.5 *Certification*—State if certification or a report of test results is required (14.1).
- 3.1.6 *Samples for Product (Check) Analysis*—Whether samples for product (check) analysis should be furnished (see 4.2).
- 3.1.7 *Purchaser Inspection*—If the purchaser wishes to witness tests or inspection of material at the place of manufacture, the purchase order must so state indicating which tests or inspections are to be witnessed (12.1).

### 4. Chemical Composition

4.1 The material shall conform to the composition limits specified in Table 1.

4.2 If a product (check) analysis is performed by the purchaser, the material shall conform to the product (check) analysis variations in accordance with Specification B880.

### 5. Mechanical Properties and Other Requirements

5.1 *Mechanical Properties*—The material shall conform to the mechanical properties specified in Table 2.

5.2 *Grain Size*—Annealed alloys UNS N08810, N08120, and UNS N08811 shall conform to an average grain size of ASTM No. 5 or coarser. Annealed alloy UNS N06674 shall conform to an average grain size of ASTM No. 7 or coarser.

### 6. Dimensions and Permissible Variations

6.1 Dimensions and tolerances shall be as specified on the applicable forging sketch or drawing.

<sup>4</sup> The last approved version of this historical standard is referenced on [www.astm.org](http://www.astm.org).

<sup>5</sup> Available from Standardization Documents Order Desk, DODSSP, Bldg. 4, Section D, 700 Robbins Ave., Philadelphia, PA 19111-5098, <http://www.dodssp.daps.mil>.

### 7. Workmanship, Finish, and Appearance

7.1 The material shall be uniform in quality and condition, sound, and free of injurious imperfections.

### 8. Sampling

#### 8.1 Lot Definition:

8.1.1 A lot for chemical analysis shall consist of one heat.

8.1.2 A lot for mechanical properties and grain size testing shall consist of all material from the same heat, size, finish, condition, and processed at one time.

#### 8.2 Test Material Selection:

8.2.1 *Chemical Analysis*—Representative samples shall be taken during pouring or subsequent processing.

8.2.1.1 Product (check) analysis shall be wholly the responsibility of the purchaser.

8.2.2 *Mechanical Properties and Grain Size*—Samples of the material to provide test specimens for mechanical properties and grain size shall be taken from such locations in each lot as to be representative of that lot.

### 9. Number of Tests

9.1 *Chemical Analysis*—One test per lot.

9.2 *Mechanical Properties*—One test per lot.

9.3 *Grain Size*—For alloys N08810, N08120, UNS N08811, and N06674, one test per lot.

### 10. Specimen Preparation

10.1 The tension test specimen representing each lot shall be taken from a forging or from a test prolongation.

10.2 The axis of the specimen shall be located at any point midway between the center and the surface of solid forgings and at any point midway between the inner and outer surfaces of the wall of hollow forgings, and shall be parallel to the direction of greatest metal flow. Specimens transverse to the direction of flow may be used provided all other requirements of this standard are satisfied.

10.3 The specimens shall be the largest possible round type shown in Test Methods E8/E8M.

### 11. Test Methods

11.1 The chemical composition, mechanical, and other properties of the material as enumerated in this specification shall be determined, in case of disagreement, in accordance with the following methods:

Test	ASTM Designation
Chemical Analysis	E76, E350, E1473
Tension	E8/E8M
Rounding Procedure	E29
Grain Size	E112

11.2 The measurement of average grain size may be carried out by the planimetric method, the comparison method, or the intercept method described in Test Methods E112. In case of dispute, the “referee” method for determining average grain size shall be the planimetric method.

11.3 For purposes of determining compliance with the specified limits for requirements of the properties listed in the

TABLE 1 Chemical Requirements<sup>A</sup>

Element	Composition, %									
	Nickel Alloy	Nickel-Copper Alloy	Low-Carbon Nickel-Molybdenum-Chromium Alloy	Nickel-Chromium-Iron-Aluminum Alloy	Low-Carbon Nickel-Chromium-Molybdenum Alloy	Low-Carbon Nickel-Chromium-Molybdenum Alloy	Nickel-Chromium-Iron-Silicon Alloy	Low-Carbon Nickel-Chromium-Molybdenum Alloy	Low-Carbon Nickel-Chromium-Molybdenum Alloy	Nickel-Chromium-Molybdenum-Tungsten Alloy
	UNS N02200	UNS N04400	UNS N06022	UNS N06025	UNS N06035	UNS N06044	UNS N06045	UNS N06058	UNS N06059	UNS N06110
Nickel	99.0 <sup>B</sup> min	63.0 <sup>B</sup> min	balance <sup>B</sup>	balance	balance <sup>B</sup>	balance	45 min	balance	balance <sup>B</sup>	51.0 <sup>B</sup> min
Copper	0.25	28.0-34.0	...	0.10	0.30	...	0.3	0.50	0.50	0.50
Iron	0.40	2.5	2.0-6.0	8.0-11.0	2.00	0.3 max	21.0-25.0	1.5	1.5	1.0
Manganese	0.35	2.0	0.50	0.15	0.50	0.07-0.30	1.0	0.50	0.5	1.0
Carbon	0.15	0.3	0.015	0.15-0.25	0.050	0.02 max	0.05-0.12	0.010	0.010	0.15
Silicon	0.35	0.5	0.08	0.5	0.60	0.20 max	2.5-3.0	0.10	0.10	1.0
Sulfur	0.01	0.024	0.02	0.01	0.015	0.020 max	0.010	0.010	0.010	0.015
Chromium	...	...	20.0-22.5	24.0-26.0	32.25-34.25	43.5-45.3	26.0-29.0	20.0-23.0	22.0-24.0	28.0-33.0
Aluminum	...	...	...	1.8-2.4	0.40	0.30 max	...	0.40	0.1-0.4	1.0
Titanium	...	...	...	0.1-0.2	...	0.10-0.30	...	...	...	1.0
Columbium (Nb) + Tantalum	...	...	...	...	...	...	...	...	...	1.0
Molybdenum	...	...	12.5-14.5	...	7.60-9.00	0.80-1.20	...	18.5-21.0	15.0-16.5	9.0-12.0
Phosphorus	...	...	0.02	0.02	0.030	0.020 max	0.02	0.015	0.015	0.50
Tungsten	...	...	2.5-3.5	...	0.60	...	...	0.3	...	1.0-4.0
Cobalt	...	...	2.5	...	1.00	...	...	0.3	0.3	...
Vanadium	...	...	0.35	...	0.20	...	...	...	...	...
Nitrogen	...	...	...	...	...	...	...	0.02 - 0.15	...	...
Boron	...	...	...	...	...	...	...	...	...	...
Lanthanum	...	...	...	...	...	...	...	...	...	...
Aluminum + Titanium	...	...	...	...	...	...	...	...	...	...
Nickel + Molybdenum	...	...	...	...	...	...	...	...	...	...
Columbium (Nb)	...	...	...	...	...	...	...	...	...	...
Tantalum	...	...	...	...	...	...	...	...	...	...
Zirconium	...	...	...	0.01-0.10	...	...	...	...	...	...
Cerium	...	...	...	...	...	...	0.03-0.09	...	...	...
Yttrium	...	...	...	0.05-0.12	...	...	...	...	...	...

<sup>A</sup> Maximum unless range or minimum is given. Where ellipses (...) appear in this table there is no requirement and the element need neither be analyzed for nor reported.

<sup>B</sup> Element shall be determined arithmetically by difference.

ASMENORMDOC.COM : Click to view the full PDF of ASME BPVC.II.B (ASME BPVC Section II part B) 2025

TABLE 1 Chemical Requirements<sup>A</sup> (continued)

Element	Composition, %								
	Low-Carbon Nickel-Chromium-Molybdenum-Copper Alloy UNS N06200	Low-Carbon Nickel-Molybdenum-Chromium-Tantalum Alloy UNS N06210	Nickel-Chromium-Molybdenum-Silicon Alloy UNS N06219	Nickel-Chromium-Tungsten-Molybdenum Alloy UNS N06230	Nickel-Chromium-Iron-Aluminum Alloy UNS N06603	Nickel-Chromium-Cobalt-Molybdenum Alloy UNS N06617	Nickel-Chromium-Molybdenum-Columbium Alloy UNS N06625	Nickel-Chromium-Iron Alloy UNS N06600	Nickel-Iron-Chromium-Tungsten Alloy UNS N06674
Nickel	balance <sup>B</sup>	balance <sup>B</sup>	balance <sup>B</sup>	balance <sup>B</sup>	balance <sup>B</sup>	44.5 min	58.0 <sup>B</sup> min	72.0 <sup>B</sup> min	balance <sup>B</sup>
Copper	1.3-1.9	...	0.50	...	0.5	0.5	...	0.5	...
Iron	3.0	1.0	2.0-4.0	3.0	8.0-11.0	3.0	5.0	6.0-10.0	20.0-27.0
Manganese	0.50	0.5	0.50	0.30-1.00	0.15	1.0	0.5	1.0	1.50
Carbon	0.010	0.015	0.05	0.05-0.15	0.20-0.40	0.05-0.15	0.10	0.15	0.10
Silicon	0.08	0.08	0.70-1.10	0.25-0.75	0.5	1.0	0.5	0.5	1.0
Sulfur	0.010	0.02	0.010	0.015	0.010	0.015	0.015	0.015	0.015
Chromium	22.0-24.0	18.0-20.0	18.0-22.0	20.0-24.0	24.0-26.0	20.0-24.0	20.0-23.0	14.0-17.0	21.5-24.5
Aluminum	0.50	...	0.50	0.50	2.4-3.0	0.8-1.5	0.4	...	...
Titanium	...	...	0.50	...	0.01-0.25	0.6	0.4	...	0.05-0.20
Columbium (Nb) + Tantalum	...	...	...	...	...	...	3.15-4.15	...	...
Molybdenum	15.0-17.0	18.0-20.0	7.0-9.0	1.0-3.0	...	8.0-10.0	8.0-10.0	...	...
Phosphorus	0.025	0.02	0.020	0.030	0.02	...	0.015	...	0.030
Tungsten	...	...	...	13.0-15.0	...	...	...	...	6.0-8.0
Cobalt	2.0	1.0	1.0	5.0	...	10.0 min-15.0	...	...	...
Vanadium	...	0.35	...	...	...	...	...	...	...
Nitrogen	...	...	...	...	...	...	...	...	0.02
Boron	...	...	...	0.015	...	0.006	...	...	0.0005-0.006
Lanthanum	...	...	...	0.005-0.050	...	...	...	...	...
Aluminum + Titanium	...	...	...	...	...	...	...	...	...
Nickel + Molybdenum	...	...	...	...	...	...	...	...	...
Columbium (Nb)	...	...	...	...	...	...	...	...	0.10-0.35
Tantalum	...	1.5-2.2	...	...	...	...	...	...	...
Zirconium	...	...	...	...	0.01-0.10	...	...	...	...
Cerium	...	...	...	...	...	...	...	...	...
Yttrium	...	...	...	...	0.01-0.15	...	...	...	...

<sup>A</sup> Maximum unless range or minimum is given. Where ellipses (...) appear in this table there is no requirement and the element need neither be analyzed for nor reported.

<sup>B</sup> Element shall be determined arithmetically by difference.

Click to view the full text of ASME BPVC.II.B (ASME BPVC Section II part B) 2025

TABLE 1 Chemical Requirements<sup>A</sup> (continued)

Element	Composition, %											
	Low-Carbon Nickel-Chromium-Molybdenum-Tungsten Alloy	Nickel-Chromium-Iron Alloy	Nickel-Chromium-Aluminum Alloy	Low-Carbon Iron-Chromium-Molybdenum-Copper Alloy	Low-Carbon Nickel-Iron-Chromium-Molybdenum-Copper Alloy	Nickel-Iron-Chromium Alloy	Iron-Nickel-Chromium-Molybdenum-Nitrogen Alloy	Nickel-Iron-Chromium Alloy	Nickel-Iron-Chromium Alloy	Nickel-Iron-Chromium Alloy	Nickel-Iron-Chromium-Molybdenum-Copper Alloy	Nickel-Iron-Chromium-Molybdenum-Copper Alloy
	UNS N06686	UNS N06690	UNS N06699	UNS N08031	UNS N08034	UNS N08120	UNS N08367	UNS N08800	UNS N08810	UNS N08811	UNS N08825	UNS N08827
Nickel	remainder	58.0 <sup>B</sup> min	remainder	30.0–32.0	33.5–35.0	35.0–39.0	23.50–25.50	30.0–35.0	30.0–35.0	30.0–35.0	38.0–46.0	39.0–43.0
Copper	...	0.5	0.50	1.0–1.4	0.5–1.5	0.50	0.75	0.75	0.75	0.75	1.5–3.0	1.6–2.3
Iron	5.0	7.0–11.0	2.5	balance <sup>B</sup>	balance <sup>B</sup>	balance	balance <sup>B</sup>	39.5 <sup>B</sup> min	39.5 <sup>B</sup> min	39.5 <sup>B</sup> min	22.0 <sup>B</sup> min	balance <sup>B</sup>
Manganese	0.75	0.5	0.50	2.0	1.0–4.0	1.5	2.00	1.5	1.5	1.5	1.0	0.5–0.9
Carbon	0.010	0.05	0.005–0.10	0.015	0.01	0.02–0.10	0.030	0.10	0.05–0.10	0.06–0.10	0.05	0.015
Silicon	0.08	0.5	0.50	0.3	0.1	1.0	1.00	1.0	1.0	1.0	0.5	0.2–0.5
Sulfur	0.02	0.015	0.01	0.010	0.010	0.03	0.030	0.015	0.015	0.015	0.03	0.005
Chromium	19.0–23.0	27.0–31.0	26.0–30.0	26.0–28.0	26.0–27.0	23.0–27.0	20.0–22.0	19.0–23.0	19.0–23.0	19.0–23.0	19.5–23.5	21.0–23.0
Aluminum	...	...	1.9–3.0	...	0.3	0.40	...	0.15–0.60	0.15–0.60	0.15–0.60	0.2	0.06–0.25
Titanium	0.02–0.25	...	0.60	...	...	0.20	...	0.15–0.60	0.15–0.60	0.15–0.60	0.6–1.2	...
Columbium (Nb) + Tantalum	...	...	...	...	...	0.4–0.9	...	...	...	...	...	...
Molybdenum	15.0–17.0	...	...	6.0–7.0	6.0–7.0	2.50	6.00–7.00	...	...	...	2.5–3.5	4.5–6.5
Phosphorus	0.04	...	0.02	0.020	0.020	0.040	0.040	...	...	...	...	...
Tungsten	3.0–4.4	...	...	...	...	2.50	...	...	...	...	...	...
Cobalt	...	...	...	...	...	3.0	...	...	...	...	...	0.5
Vanadium	...	...	...	...	...	...	...	...	...	...	...	...
Nitrogen	...	...	0.05	0.15–0.25	0.10–0.25	0.15–0.30	0.18–0.25	...	...	...	...	0.03
Boron	...	...	0.008	...	...	0.010	...	...	...	...	...	0.002–0.004
Lanthanum	...	...	...	...	...	...	...	...	...	...	...	...
Aluminum + Titanium	...	...	...	...	...	...	...	...	...	0.85–1.20	...	...
Nickel + Molybdenum	...	...	...	...	...	...	...	...	...	...	...	...
Columbium (Nb)	...	...	0.50	...	...	...	...	...	...	...	...	0.15
Tantalum	...	...	...	...	...	...	...	...	...	...	...	...
Zirconium	...	...	0.10	...	...	...	...	...	...	...	...	...
Cerium	...	...	...	...	...	...	...	...	...	...	...	...
Yttrium	...	...	...	...	...	...	...	...	...	...	...	...
Magnesium	...	...	...	...	...	...	...	...	...	...	...	0.006–0.015

<sup>A</sup> Maximum unless range or minimum is given. Where ellipses (...) appear in this table there is no requirement and the element need neither be analyzed for nor reported.

<sup>B</sup> Element shall be determined arithmetically by difference.

ASME NORMDOC.COM Click to view the full PDF of ASME BPVC.II.B (ASME BPVC Section II part B) 2025

TABLE 1 Chemical Requirements<sup>A</sup> (continued)

Element	Composition, %								
	Nickel-Molybdenum-Chromium-Iron Alloy UNS N10242	Low-Carbon Nickel-Molybdenum-Chromium Alloy UNS N10276	Low-Carbon Nickel-Molybdenum-Chromium Alloy UNS N10362	Nickel-Molybdenum-Chromium-Iron Alloy UNS N10624	Nickel-Molybdenum Alloy UNS N10629	Nickel-Molybdenum Alloy UNS N10665	Nickel-Molybdenum Alloy UNS N10675	Nickel-Cobalt-Chromium-Silicon Alloy UNS N12160	Chromium-Nickel-Iron-Nitrogen Alloy UNS R200033
Nickel	balance <sup>B</sup>	balance <sup>B</sup>	balance <sup>B</sup>	balance <sup>B</sup>	balance	balance <sup>B</sup>	65.0 min	balance <sup>B</sup>	30.0–33.0
Copper	...	...	...	0.5	0.5	...	0.20	...	0.30–1.20
Iron	2.0	4.0–7.0	1.25	5.0–8.0	1.0–6.0	2.0	1.0–3.0	3.5	balance <sup>B</sup>
Manganese	0.80	1.0	0.60	1.0	1.5	1.0	3.0	1.5	2.0
Carbon	0.03	0.010	0.010	0.01	0.010	0.02	0.01	0.15	0.015
Silicon	0.80	0.08	0.08	0.10	0.05	0.10	0.10	2.4–3.0	0.50
Sulfur	0.015	0.03	0.010	0.01	0.01	0.03	0.010	0.015	0.01
Chromium	7.0–9.0	14.5–16.5	13.8–15.6	6.0–10.0	0.5–1.5	1.0	1.0–3.0	26.0–30.0	31.0–35.0
Aluminum	0.50	...	0.50	0.5	0.1–0.5	...	0.50	...	...
Titanium	...	...	...	...	...	...	0.20	0.20–0.80	...
Columbium (Nb) + Tantalum	...	...	...	...	...	...	...	...	...
Molybdenum	24.0–26.0	15.0–17.0	21.5–23.0	21.0–25.0	26.0–30.0	26.0–30.0	27.0–32.0	1.0	0.50–2.0
Phosphorus	0.030	0.04	0.025	0.025	0.04	0.04	0.030	0.030	0.02
Tungsten	...	3.0–4.5	...	...	...	...	3.0	1.0	...
Cobalt	1.00	2.5	...	1.0	2.5	1.00	3.0	27.0–33.0	...
Vanadium	...	0.35	...	...	...	...	0.20	...	...
Nitrogen	...	...	...	...	...	...	...	...	0.35–0.60
Boron	0.006	...	...	...	...	...	...	...	...
Lanthanum	...	...	...	...	...	...	...	...	...
Aluminum + Titanium	...	...	...	...	...	...	...	...	...
Nickel + Molybdenum	...	...	...	...	...	...	94.0–98.0	...	...
Columbium (Nb)	...	...	...	...	...	...	0.20	1.0	...
Tantalum	...	...	...	...	...	...	0.20	...	...
Zirconium	...	...	...	...	...	...	0.10	...	...
Cerium	...	...	...	...	...	...	...	...	...
Yttrium	...	...	...	...	...	...	...	...	...

<sup>A</sup> Maximum unless range or minimum is given. Where ellipses (...) appear in this table there is no requirement and the element need neither be analyzed for nor reported.

<sup>B</sup> Element shall be determined arithmetically by difference.

TABLE 2 Mechanical Property Requirements<sup>A</sup>

Material and Condition	Maximum Section Thickness or Diameter, in. (mm)	Tensile Strength, min, ksi (MPa)	Yield Strength, 0.2 % Offset, min, ksi (MPa)	Elongation in 2 in. or 50 mm or 4D, min, %
Iron-nickel-chromium-molybdenum-nitrogen alloy UNS N08367, solution annealed	...	95 (655)	45 (310)	30
Low-carbon chromium-nickel-iron-nitrogen alloy UNS R20033, solution annealed	...	109 (750)	55 (380)	40
Low-carbon nickel-chromium-molybdenum alloy UNS N06035, solution annealed	...	85 (586)	35 (241)	30
Low-carbon nickel-chromium-molybdenum alloy UNS N06044, solution annealed	...	100 (690)	45 (310)	30
Low-carbon nickel-chromium-molybdenum alloy UNS N06058, solution annealed	...	110 (760)	52 (360)	40
Low-carbon nickel-chromium-molybdenum alloy UNS N06059, solution annealed	...	100 (690)	45 (310)	45
Low-carbon nickel-chromium-molybdenum-copper alloy UNS N06200, solution annealed	...	100 (690)	45 (310)	45
Low-carbon nickel-chromium-molybdenum-tungsten alloy UNS N06686, solution annealed	...	100 (690)	45 (310)	45
Low-carbon nickel-iron-chromium-molybdenum-copper alloy UNS N08031, solution annealed	...	94 (650)	40 (276)	40
Low-carbon nickel-iron-chromium-molybdenum-copper alloy UNS N08034, solution annealed	...	94 (650)	40 (280)	40
Low-carbon nickel-chromium-molybdenum alloy UNS N10276, solution annealed	...	100 (690)	41 (283)	40
Low-carbon nickel-chromium-molybdenum alloy UNS N06022, solution annealed	...	100 (690)	45 (310)	45
Low-carbon nickel-molybdenum-chromium alloy UNS N10362, solution annealed	...	105 (725)	45 (310)	40
Low-carbon nickel-molybdenum-chromium-tantalum alloy UNS N06210, solution annealed	...	100 (690)	45 (310)	45
Nickel alloy UNS N02200, annealed	...	55 (380)	15 (105)	40
Nickel-cobalt-chromium-silicon alloy UNS N12160, solution annealed	...	90 (620)	35 (240)	40
Nickel-chromium-aluminum alloy UNS N06699, solution annealed	...	89 (610)	35 (240)	40
Nickel-chromium-cobalt-molybdenum alloy UNS N06617, annealed	...	95 (655)	35 (241)	35
Nickel-chromium-iron alloy UNS N06600, annealed	...	80 (552)	35 (241)	30
Nickel-chromium-iron-aluminum alloy UNS N06603, annealed	...	94 (650)	43 (300)	25
Nickel-chromium-iron alloy UNS N06690, annealed	...	85 (586)	35 (241)	30
Nickel-chromium-iron-aluminum alloy UNS N06025, solution annealed	Up to 4 (102)	98 (680)	39 (270)	30
Nickel-chromium-iron-silicon alloy UNS N06045, solution annealed	Over 4 (102) to 12 (305) incl	84 (580)	39 (270)	15
Nickel-chromium-molybdenum-columbium alloy UNS N06625 grade 1, (annealed) <sup>F</sup>	...	90 (620)	35 (240)	35
Nickel-chromium-molybdenum-columbium alloy UNS N06625 grade 2, (solution annealed) <sup>C</sup>	Up to 4 (102), incl	120 (827)	60 (414)	30
Nickel-chromium-molybdenum-silicon alloy UNS N06219, solution annealed	Over 4 (102) to 10 (254), incl	110 (758)	50 (345)	25
Nickel-chromium-molybdenum-columbium alloy UNS N06625 grade 2, (solution annealed) <sup>C</sup>	All sizes	100 (690)	40 (276)	30
Nickel-chromium-molybdenum-tungsten alloy UNS N06110, annealed	...	96 (660)	39 (270)	50
Nickel-chromium-tungsten-molybdenum alloy UNS N06230, solution annealed <sup>D</sup>	Up to 4 (102), incl	95 (655)	45 (310)	60
Nickel-copper alloy UNS N04400, annealed	Over 4 (102) to 10 (254), incl	90 (621)	40 (276)	50
Nickel-chromium-tungsten-molybdenum alloy UNS N06230, solution annealed <sup>D</sup>	...	110 (758)	45 (310)	40
Nickel-copper alloy UNS N04400, annealed	...	70 (483)	25 (172)	35

ASME NIP 2025 Link to view the full PDF of ASME BPVC.II.B (ASME BPVC Section II part B) 2025

TABLE 2 Continued

Material and Condition	Maximum Section Thickness or Diameter, in. (mm)	Tensile Strength, min, ksi (MPa)	Yield Strength, 0.2 % Offset, min, ksi (MPa)	Elongation in 2 in. or 50 mm or 4D, min, %
Nickel-iron-chromium alloys:				
UNS N08120, solution annealed	...	90 (621)	40 (276)	30
UNS N08800, annealed	...	75 (517)	30 (207)	30
UNS N08810 and UNS N08811, annealed	...	65 (448)	25 (172)	30
Nickel-iron-chromium-molybdenum-copper alloys:				
UNS N08825, annealed	...	85 (586)	35 (241)	30
UNS N08827, annealed	...	85 (586)	35 (241)	30
Nickel-iron-chromium-tungsten alloy UNS N06674, solution annealed <sup>D</sup>	...	86 (590)	34 (235)	30
Nickel-molybdenum alloy UNS N10665, solution annealed	...	110 (760)	51 (350)	40
Nickel-molybdenum alloy UNS N10675, solution annealed	...	110 (760)	51 (350)	40
Nickel-molybdenum alloy UNS N10629, solution annealed	...	110 (760)	51 (350)	40
Nickel-molybdenum-chromium-iron alloy UNS N10242, annealed	...	105 (725)	45 (310)	40
Nickel-molybdenum-chromium-iron alloy UNS N10624, annealed	...	104 (720)	46 (320)	40

<sup>A</sup> Forging quality is furnished to chemical requirements and surface inspection only.

<sup>B</sup> Annealed at 1600 °F (871 °C) minimum.

<sup>C</sup> Solution annealed at 2000 °F (1093 °C) minimum, with or without subsequent stabilization anneal at 1800 °F (982 °C) minimum to increase resistance to sensitization.

<sup>D</sup> Solution annealed at a minimum temperature of 2150 °F (1177 °C) followed by a water quench or rapidly cooled by other means.

following table, an observed value, or a calculated value, shall be rounded as indicated as follows, in accordance with the rounding method of Practice E29:

Test	Rounded Unit for Observed or Calculated Value
Chemical composition	nearest unit in the last right-hand place of figures of the specified limit
Tensile strength, yield strength	nearest 1000 psi (6.9 MPa)
Elongation	nearest 1 %
Grain size:	
0.0024 in. (0.060 mm) or larger	nearest multiple of 0.0002 in. (0.005 mm)
less than 0.0024 in. (0.060 mm)	nearest multiple of 0.0001 in. (0.002 mm)

## 12. Inspection

12.1 Inspection of the material by the purchaser shall be made as agreed upon between the purchaser and the seller as part of the purchase contract.

## 13. Rejection and Reheating

13.1 Material, tested by the purchaser, that fails to conform to the requirements of this specification may be rejected. Rejection should be reported to the producer or supplier

promptly and in writing. In case of dissatisfaction with the results of the test, the producer or supplier may make claim for a reheating.

## 14. Certification

14.1 When specified in the purchase order or contract, a manufacturer's certification shall be furnished to the purchaser stating that material has been manufactured, tested, and inspected in accordance with this specification, and that the test results on representative samples meet specification requirements. When specified in the purchase order or contract, a report of the test results shall be furnished.

## 15. Product Marking

15.1 The material shall be marked legibly with the name of the material, this specification number, the heat number and condition, and such other information as may be defined in the contract or order.

## 16. Keywords

16.1 nickel alloy forgings

## SUPPLEMENTARY REQUIREMENTS

The following supplementary requirements shall apply only when specified by the purchaser in the inquiry, contract, or order, for agencies of the U.S. Government.

### S1. Referenced Documents

S1.1 The following documents of the issue in effect on date of material purchase form a part of this specification to the extent referenced herein.

#### S1.1.1 Federal Standards:

Fed. Std. No. 102 Preservation, Packaging and Packing Levels

Fed. Std. No. 123 Marking for Shipment (Civil Agencies)

Fed. Std. No. 185 Identification Marking of Copper and Copper-Base Alloy Mill Products

#### S1.1.2 Military Standards:

MIL-STD-129 Marking for Shipment and Storage

#### S1.1.3 Military Specification:

MIL-C-3993 Packaging of Copper

MIL-STD-792 Copper-Base Alloy Mill Products

### S2. Chemical Composition

S2.1 UNS alloy N04400 shall conform to the composition limits specified in Table 1 except as specified in Table S2.1.

### S3. Mechanical Properties

S3.1 Mechanical property requirements for UNS alloy N04400 forgings in the hot finished and hot finished/high tensile conditions shall be as specified in Table S3.1.

### S4. Number of Tests

S4.1 One tensile specimen is required for each forging greater than 250 lb in as shipped weight.

### S5. Nondestructive Tests

S5.1 When specified by the purchaser, each piece of each lot shall be inspected. The purchaser shall specify if one or both tests are required.

#### S5.2 Ultrasonic Tests:

##### S5.2.1 General Requirements:

S5.2.1.1 Ultrasonic testing shall be performed in accordance with MIL-STD-271 as modified by the requirements specified herein. Testing shall be done by a longitudinal wave or shear wave technique as specified herein.

S5.2.1.2 Acoustic compatibility between the production material and the calibration standard material shall be within 75 %. If the acoustic compatibility is within 25 %, no gain

compensation is required for the examination. If acoustic compatibility difference is between 25 % and 75 %, a change in the gain or dB controls shall be accomplished to compensate for the differences in acoustic compatibility. This method cannot be used if the ultrasonic noise level exceeds 50 % of the rejection value.

#### S5.2.2 Calibration:

S5.2.2.1 *Shear Wave*—The shear wave test shall be calibrated on two notches, one notch cut into the inside and one into the outside surface. The notches shall be cut axially and shall have a depth of 5 % of the material thickness of ¼ in. (6.4 mm), whichever is less. Notch length shall not exceed 1 in. (25.4 mm). Notches shall be made either in the piece to be examined or in a separate defect-free specimen of the same size (within ± ⅛ in. (3.18 mm)), shape, material, and condition, or acoustically similar material. The position and amplitude of the response from each notch shall be marked on the instrument screen or a transparent overlay, and these marks shall be used as the evaluation reference. Indications that appear between these points shall be evaluated on the basis of a straight line joining the two peak amplitudes.

S5.2.2.2 *Longitudinal Wave*—The longitudinal wave test shall be calibrated on a flat-bottomed reference hole of a given diameter in accordance with Table S5.1 for specified material thickness drilled either into the piece to be tested or into a separate defect-free specimen of the same size (within ± ⅛ in. (3.18 mm)), shape, material, and condition, or acoustically similar material. Holes are to be drilled to midsection and the bottom of the hole shall be parallel to the entrant surface. The ultrasonic test instrument shall be adjusted so that the response from the reference hole shall not be less than 25 % and not more than 75 % of screen height.

S5.2.2.3 *Recalibration*—During quality conformance inspection, any realignment of the search unit that will cause a decrease in the calibrated sensitivity and resolution, or both, or any change in search unit, couplant, instrument settings, or scanning speed from that used for calibration shall require recalibration. Recalibration shall be performed at least once per 8-h shift.

S5.2.3 *Procedure*—Paragraphs S5.2.3.1 through S5.2.3.4 describe the requirements for rod, bar, and simple forged shapes.

S5.2.3.1 *Rod*—Rod shall be testing using the longitudinal wave technique. The scanning path shall be circumferential or helical with the beam directed along a radius of the rod.

S5.2.3.2 *Bar*—Bar shall be tested using the longitudinal wave technique through one side of each pair of parallel sides (thickness and width only).

S5.2.3.3 *Ring and Hollow Round Products*—Rings and other hollow cylindrical products shall be tested using the shear wave method by the contact or immersion technique. The shear wave entrant angle shall be such to ensure reflection from the notch or notches used in calibration. For contact testing, the

TABLE S2.1 Chemical Requirements

Element	Composition Limits, %	
	UNS 04400	
Carbon	0.2 max	
Sulfur	0.015 max	
Aluminum	0.5 max	
Lead	0.006 max	
Tin	0.006 max	
Zinc	0.02 max	
Phosphorous	0.02 max	

TABLE S3.1 Mechanical Properties of UNS N04400 Forgings

Condition and Diameter Between Parallel Surfaces, in. (mm)	Tensile Strength, min, psi (Mpa)	Yield Strength, min, psi (Mpa) (0.2 % offset)	Elongation in 2 in. or 50 mm, or 4D, min, %
Hot Finished - to 12 (305)	80 000 (552)	40 000 (276)	30
Hot Finished - over 12 (305)	75 000 (517)	40 000 (276)	30
Hot Finished/High Tensile - Rounds 3 to 6 (76 to 152) inclusive	95 000 (655)	70 000 (483)	20
Hot Finished/High Tensile - Rounds over 6 to 12 (152 to 305) and hex, squares, and flats 3 to 12 (76 to 305)	85 000 (586)	60 000 (414)	25

TABLE S5.1 Ultrasonic Testing Reference Hole for Rod, Bar, Disc, Pancake Forgings, and Forgings

Material Thickness, in. (mm)	Hole Diameter, in. (mm)
Up to and including 6 (152)	1/8 5(3.18)
Over 6 (152) and including 16 (406)	1/4 (6.4)
Over 16 (406)	As agreed upon

search unit shall be fitted with a wedge or shoe machined to fit the curvature of the piece being inspected. The product also shall be inspected with a longitudinal wave test from the external circumferential and end surfaces.

S5.2.3.4 *Disc or Pancake Forgings*—Disc or pancake forgings shall be inspected with a longitudinal wave technique from both parallel surfaces.

S5.2.4 *Acceptance Criteria:*

S5.2.4.1 *Shear Wave*—Any material that produces indications equal to or larger than the response from the reference notch or higher than the straight line joining the two peak amplitudes shall be rejected.

S5.2.4.2 *Longitudinal Wave*—Any material that produces indications equal to or larger than the response from the reference hole, or that produces a complete loss of back reflection shall be rejected. Material shall be tested using a square, rectangular, or circular transducer having an effective area of one square inch or less, but no dimension shall be smaller than the diameter of the reference hole. In the event of disagreement on the degree of back reflection loss, it shall be determined by the contact method using a 1 to 1½ in. (25.4 to 28.6 mm) diameter transducer or one whose area falls within this range.

S5.2.4.3 *Reference Notch Removal*—If reference notches or flat-bottomed holes are made in the material to be tested, they shall be so located that their subsequent removal will not impair the suitability of the material for its intended use.

S5.3 *Liquid Penetrant Inspection:*

S5.3.1 *Procedure*—Liquid penetrant inspection shall be in accordance with MIL-STD-271.

S5.3.2 *Surface Requirements*—The surface produced by hot working is not suitable for liquid penetrant testing. Therefore, liquid penetrant testing will not be applicable to products ordered with a hot finished surface.

S5.3.3 *Acceptance Criteria*—Linear defects revealed by liquid penetrant inspection shall be explored by grinding or other suitable means. Depth of defects shall not exceed the dimensional tolerance of the material.

## S6. Quality Assurance

S6.1 *Responsibility for Inspection:*

S6.1.1 Unless otherwise specified in the contract or purchase order, the manufacturer is responsible for the performance of all inspections and test requirements specified. Except as otherwise specified in the contract or purchase order, the manufacturer may use his own or any other suitable facilities for the performance of the inspection and test requirements unless disapproved by the purchaser at the time the order is placed. The purchaser shall have the right to perform any of the inspections or tests set forth when such inspections and tests are deemed necessary to ensure that the material conforms to prescribed requirements.

## S7. Identification Marking

S7.1 All material shall be properly marked for identification in accordance with Fed. Std. No. 185 except that the ASTM specification number and the alloy number shall be used. In addition, the method and location of marking shall be in accordance with MIL-STD-792. Forging stock shall be marked with low stress die stamps or vibroetching.

## S8. Preparation for Delivery

S8.1 *Preservation, Packaging, and Packing:*

S8.1.1 *Military Agencies*—The material shall be separated by size, composition, grade, or class, and shall be preserved and packaged level A or C, and packed Level A, B, or C as specified in the contract or purchase order.

S8.1.2 *Civil Agencies*—The requirements of Fed. Std. No. 102 shall be referenced for definitions for the various levels of packaging protection.

S8.2 *Marking:*

S8.2.1 *Military Agencies*—In addition to any special marking required by the contract or purchase order, marking for shipment shall be in accordance with MIL-STD-129.

S8.2.2 *Civil Agencies*—In addition to any special marking required by the contract or purchase order, marking for shipment shall be in accordance with Fed. Std. No. 123.

SUMMARY OF CHANGES

Committee B02 has identified the location of selected changes to this standard since the last issue (B564 – 19) that may impact the use of this standard. (Approved April 1, 2022.)

- (1) Added two different grades for N06625 in base of heat treatment condition in 1.1.3.
- (2) Added mechanical property data to Table 2 for UNS N06625 grade 2 (solution annealed).
- (3) Replaced previous footnote B and added new footnote C to Table 2.

*ASTM International takes no position respecting the validity of any patent rights asserted in connection with any item mentioned in this standard. Users of this standard are expressly advised that determination of the validity of any such patent rights, and the risk of infringement of such rights, are entirely their own responsibility.*

*This standard is subject to revision at any time by the responsible technical committee and must be reviewed every five years and if not revised, either reapproved or withdrawn. Your comments are invited either for revision of this standard or for additional standards and should be addressed to ASTM International Headquarters. Your comments will receive careful consideration at a meeting of the responsible technical committee, which you may attend. If you feel that your comments have not received a fair hearing you should make your views known to the ASTM Committee on Standards, at the address shown below.*

*This standard is copyrighted by ASTM International, 100 Barr Harbor Drive, PO Box C700, West Conshohocken, PA 19428-2959, United States. Individual reprints (single or multiple copies) of this standard may be obtained by contacting ASTM at the above address or at 610-832-9585 (phone), 610-832-9555 (fax), or service@astm.org (e-mail); or through the ASTM website (www.astm.org). Permission rights to photocopy the standard may also be secured from the Copyright Clearance Center, 222 Rosewood Drive, Danvers, MA 01923, Tel: (978) 646-2600; http://www.copyright.com/*

ASME B02.C Section II part B) 2025  
ASME BPVC.II.B-2025  
Click to view the full PDF of ASME BPVC.II.B-2025  
ASME B02.C Section II part B) 2025

# SPECIFICATION FOR UNS N06002, UNS N06230, UNS N12160, AND UNS R30556 ROD



SB-572

(Identical with ASTM Specification B572-06(2011) except that E527 was removed from References, and certification has been made mandatory.)

# Standard Specification for UNS N06002, UNS N06230, UNS N12160, and UNS R30556 Rod

## 1. Scope

1.1 This specification covers alloys UNS N06002, UNS N06230, UNS N12160, and UNS R30556 in the form of rod for heat resisting and general-corrosive service.

1.2 The following products are covered under this specification:

1.2.1 Rods  $\frac{5}{16}$  to  $\frac{3}{4}$  in. (7.94 to 19.05 mm) exclusive in diameter, hot or cold finished, solution-annealed, and pickled or mechanically descaled.

1.2.2 Rods  $\frac{3}{4}$  to  $3\frac{1}{2}$  in. (19.05 to 88.9 mm) inclusive in diameter, hot or cold finished, solution annealed, ground, or turned.

1.3 The values stated in inch-pound units are to be regarded as standard. The values given in parentheses are mathematical conversions to SI units that are provided for information only and are not considered standard.

1.4 *This standard does not purport to address all of the safety concerns, if any, associated with its use. It is the responsibility of the user of this standard to become familiar with all hazards including those identified in the appropriate Material Safety Data Sheet (MSDS) for this product/material as provided by the manufacturer, to establish appropriate safety and health practices, and determine the applicability of regulatory limitations prior to use.*

## 2. Referenced Documents

### 2.1 ASTM Standards:

B880 Specification for General Requirements for Chemical

Check Analysis Limits for Nickel, Nickel Alloys and Cobalt Alloys

E8 Test Methods for Tension Testing of Metallic Materials

E29 Practice for Using Significant Digits in Test Data to Determine Conformance with Specifications

E55 Practice for Sampling Wrought Nonferrous Metals and Alloys for Determination of Chemical Composition

E527 Practice for Numbering Metals and Alloys in the Unified Numbering System (UNS)

E1473 Test Methods for Chemical Analysis of Nickel, Cobalt, and High-Temperature Alloys

## 3. Terminology

### 3.1 Definitions of Terms Specific to This Standard:

3.1.1 *rod, n*—product of round solid section furnished in straight lengths.

## 4. Ordering Information

4.1 It is the responsibility of the purchaser to specify all requirements that are necessary for material ordered under this specification. Examples of such requirements include, but are not limited to the following:

4.1.1 *Alloy*,

4.1.2 *Dimensions*—Nominal diameter and length. The shortest useable multiple length should be specified (Table 1),

4.1.3 *Certification*—State if certification or a report of test results is required (Section 16).

4.1.4 *Purchaser Inspection*—State which tests or inspections are to be witnessed (Section 13), and

4.1.5 *Samples for Product (Check) Analysis*—State whether samples should be furnished (9.2.2).

## 5. Chemical Composition

5.1 The material shall conform to the requirements as to chemical composition prescribed in Table 2.

5.2 If a product (check) analysis is made by the purchaser, the material shall conform to the requirements specified in Table 2 subject to the permissible tolerances in Specification B880.

## 6. Mechanical and Other Requirements

6.1 The mechanical properties of the material at room temperature shall conform to those shown in Table 3.

**TABLE 1 Permissible Variations in Length of Rods**

Random mill lengths	2 to 12 ft (610 to 3660 mm) long with not more than 25 weight % under 4 ft (1.22 m).
Multiple lengths	Furnished in multiples of a specified unit length, within the length limits indicated above. For each multiple, an allowance of 1/4 in. (6.35 mm) shall be made for cutting, unless otherwise specified. At the manufacturer's option, individual specified unit lengths may be furnished.
Nominal lengths	Specified nominal lengths having a range of not less than 2 ft (610 mm) with no short lengths allowed.
Cut lengths	A specified length to which all rods shall be cut with a permissible variation of + 1/8 in. (3.17 mm) – 0.

**TABLE 2 Chemical Requirements**

Element	Composition Limits, %			
	UNS N06002	UNS N06230	UNS N12160	UNS R30556
Nickel	remainder <sup>A</sup>	remainder <sup>A</sup>	remainder <sup>A</sup>	19.0–22.5
Iron	17.0–20.0	3.0 max	3.5 max	remainder <sup>A</sup>
Chromium	20.5–23.0	20.0–24.0	26.0–30.0	21.0–23.0
Cobalt	0.5–2.5	5.0 max	27.0–33.0	16.0–21.0
Molybdenum	8.0–10.0	1.0–3.00	1.0 max	2.5–4.0
Tungsten	0.2–1.0	13.0–15.0	1.0 max	2.0–3.5
Carbon	0.05–0.15	0.05–0.15	0.15 max	0.05–0.15
Silicon	1.00 max	0.25–0.75	2.4–3.0	0.20–0.80
Manganese	1.00 max	0.30–1.00	1.5 max	0.50–2.00
Phosphorus	0.04	0.030 max	0.030 max	0.04 max
Sulfur	0.03	0.015 max	0.015 max	0.015 max
Columbium	...	...	1.0 max	0.30 max
Tantalum	...	...	...	0.30–1.25
Aluminum	...	0.50 max	...	0.10–0.50
Zirconium	...	...	...	0.001–0.10
Lanthanum	...	0.005–0.050	...	0.005–0.10
Nitrogen	...	...	...	0.10–0.30
Boron	...	0.015 max	...	0.02 max
Titanium	...	...	0.20–0.80	...

<sup>A</sup> See 12.1.1.

**TABLE 3 Mechanical Property Requirements**

UNS	Tensile Strength, min, ksi (MPa)	Yield Strength (0.2 % Offset), min, ksi (MPa)	Elongation in 2 in. (50.8mm) or 4D <sup>A</sup> min, %
N06002	95 (660)	35 (240)	35
N06230 <sup>B</sup>	110 (760)	45 (310)	40
N12160 <sup>C</sup>	90 (620)	35 (240)	40
R30556 <sup>D</sup>	100 (690)	45 (310)	40

<sup>A</sup> D refers to the diameter of the tension specimen.

<sup>B</sup> Solution annealed at a temperature between 2200 to 2275°F (1204 to 1246°C) followed by a water quench or rapidly cooled by other means.

<sup>C</sup> Solution annealed at 1950°F (1065°C) minimum.

<sup>D</sup> Solution annealed at 2100°F (1150°C) minimum.

6.2 *Grain Size*—Annealed alloy (UNS N12160) shall conform to an average grain size of ASTM Number 5 or coarser.

## 7. Dimensions, Mass, and Permissible Variations

7.1 *Diameter*—The permissible variations from the specified diameter shall be as prescribed in Table 4.

7.2 *Out-of-Roundness*—The permissible variation in roundness shall be as prescribed in Table 4.

7.3 *Machining Allowances*—When the surfaces of finished material are to be machined, the following allowances are suggested for normal machining operations:

7.3.1 *As-finished* (Annealed and Descaled)—For diameters of 5/16 to 1 1/16 in. (7.94 to 17.46 mm) inclusive, an allowance of 1/16 in. (1.59 mm) on the diameter should be made for finish machining.

### 7.4 Length:

7.4.1 Unless multiple, nominal, or cut lengths are specified, random mill lengths shall be furnished.

7.4.2 The permissible variations in length of multiple, nominal, or cut length rod shall be as prescribed in Table 1. Where rods are ordered in multiple lengths, a 1/4-in. (6.35-mm) length addition shall be allowed for each uncut multiple length.

### 7.5 Ends:

7.5.1 Rods ordered to random or nominal lengths shall be furnished with either cropped or sawed ends.

7.5.2 Rods ordered to cut lengths shall be furnished with square saw cut or machined ends.

7.6 *Weight*—For calculations of mass or weight, the following densities shall be used:

Alloy	lb/in. <sup>3</sup>	Density (g/cm <sup>3</sup> )
N06002	0.297	(8.23)
N06230	0.324	(8.97)
N12160	0.292	(8.08)
R30556	0.297	(8.23)

7.7 *Straightness*—The maximum curvature (depth of chord) shall not exceed 0.050 in. multiplied by the length of the chord in feet (0.04 mm multiplied by the length in centimetres).

## 8. Workmanship, Finish, and Appearance

8.1 The material shall be uniform in quality and condition, smooth, and free of injurious defects.

## 9. Sampling

### 9.1 Lots for Chemical Analysis and Mechanical Testing:

9.1.1 A lot for chemical analysis shall consist of one heat.

9.1.2 A lot of bar for mechanical testing shall be defined as the material from one heat in the same condition and specified diameter.

### 9.2 Sampling for Chemical Analysis:

9.2.1 A representative sample shall be obtained from each heat during pouring or subsequent processing.

9.2.2 Product (check) analysis shall be wholly the responsibility of the purchaser.

9.3 *Sampling for Mechanical Testing*—A representative sample shall be taken from each lot of finished material.

## 10. Number of Tests and Retests

10.1 *Chemical Analysis*, One test per heat.

10.2 *Tension Tests*—One test per lot.

10.3 *Retests*—If the specimen used in the mechanical test of any lot fails to meet the specified requirements, two additional specimens shall be taken from different sample pieces and tested. The results of the tests on both of these specimens shall meet the specified requirements.

TABLE 4 Permissible Variations in Diameter and Out-of-Roundness of Finished Rods

Specified Diameter, in. (mm)	Permissible Variations, in. (mm)		
	Diameter		Out of Roundness, max
	+	-	
	Hot-Finished, Annealed, and Descaled Rods		
5/16 to 7/16 (7.94–11.11), incl	0.012 (0.30)	0.012 (0.30)	0.018 (0.46)
Over 7/16 to 5/8 (11.11–15.87), incl	0.014 (0.36)	0.014 (0.36)	0.020 (0.51)
Over 5/8 to 3/4 (15.87–19.05), excl	0.016 (0.41)	0.016 (0.41)	0.024 (0.61)
	Hot-Finished, Annealed, and Ground or Turned Rods		
3/4 to 3 1/2 (19.05–88.9), incl	0.010 (0.25)	0	0.008 (0.20)

## 11. Specimen Preparation

11.1 Tension test specimens shall be taken from material after final heat treatment and tested in the direction of fabrication.

11.2 Tension test specimens shall be any of the standard or subsized specimens shown in Test Methods E8.

11.3 In the event of disagreement, the referee specimen shall be the largest possible round specimen shown in Test Methods E8.

## 12. Test Methods

12.1 The chemical composition and mechanical properties of the material as enumerated in this specification shall be determined, in case of disagreement, in accordance with the following ASTM methods:

12.1.1 *Chemical Analysis*—Test Methods E1473. For elements not covered by Test Methods E1473, the referee method shall be as agreed upon between the manufacturer and the purchaser. The composition of the remainder element shall be determined arithmetically by difference.

12.1.2 *Tension Test*—Test Methods E8.

12.1.3 *Method of Sampling*—Practice E55.

12.1.4 *Determining Significant Places*—Practice E29.

12.2 For purposes of determining compliance with the limits in this specification, an observed value or a calculated value shall be rounded in accordance with the rounding method of Practice E29:

Requirements	Rounded Unit for Observed or Calculated Value
Chemical composition and tolerance	nearest unit in the last right-hand place of figures of the specified limit
Tensile strength and yield strength	nearest 1000 psi (7 MPa)
Elongation	nearest 1 %

## 13. Inspection

13.1 Inspection of the material shall be made as agreed upon between the manufacturer and the purchaser as part of the purchase contract.

## 14. Rejection and Rehearing

14.1 Material, tested by the purchaser, that fails to conform to the requirements of this specification may be rejected. Rejection should be reported to the producer or supplier promptly and in writing. In case of dissatisfaction with the results of the test, the producer or supplier may make claim for a rehearing.

## 15. Certification

15.1 A manufacturer's certification shall be furnished to the purchaser stating that material has been manufactured, tested, and inspected in accordance with this specification, and that the test results on representative samples meet specification requirements. A report of the test results shall be furnished.

## 16. Product Marking

16.1 Each piece of material 1/2 in. (12.7 mm) and over in diameter shall be marked with this specification number alloy, name of the material, and size of the product.

16.2 Each bundle or shipping container shall be marked with the name of the material; this specification number alloy; the size; gross, tare, and net weight; consignor and consignee address; contract or order number; and such other information as may be defined in the contract or order.

## 17. Keywords

17.1 rod; N06002; N06230; N12160; R30556

**APPENDIX****(Nonmandatory Information)****X1. HEAT TREATMENT**

X1.1 Proper heat treatment during or subsequent to fabrication is necessary for optimum performance, and the manufacturer shall be consulted for details.

ASMENORMDOC.COM : Click to view the full PDF of ASME BPVC.II.B (ASME BPVC Section II part B) 2025

ASMENORMDOC.COM : Click to view the full PDF of ASME BPVC.II.B (ASME BPVC Section II part B) 2025

INTENTIONALLY LEFT BLANK

# SPECIFICATION FOR NICKEL-MOLYBDENUM- CHROMIUM-IRON ALLOYS (UNS N10003, N10242) ROD



SB-573

(Identical with ASTM Specification B573-06(2016) except that certification and test reports have been made mandatory.)

ASMENORMDOC.COM : Click to view the full PDF of ASME BPVC.II.B (ASME BPVC Section II part B) 2025

# Specification for Nickel-Molybdenum-Chromium-Iron Alloys (UNS N10003, N10242) Rod

## 1. Scope

1.1 This specification covers nickel-molybdenum-chromium-iron alloys (UNS N10003 and UNS N10242) rod for use in general corrosive service.

1.2 The following products are covered under this specification:

1.2.1 Rods  $\frac{5}{16}$  to  $\frac{3}{4}$  in. (7.94 to 19.05 mm) excl in diameter, hot or cold finished, annealed, and pickled or mechanically descaled.

1.2.2 Rods  $\frac{3}{4}$  to  $3\frac{1}{2}$  in. (19.05 to 88.9 mm) incl in diameter, hot or cold finished, annealed, ground, or turned.

1.3 The values stated in inch-pound units are to be regarded as standard. The values given in parentheses are mathematical conversions to SI units that are provided for information only and are not considered standard.

1.4 *This standard does not purport to address all of the safety concerns, if any, associated with its use. It is the responsibility of the user of this standard to become familiar with all hazards including those identified in the appropriate Safety Data Sheet (SDS) for this product/material as provided by the manufacturer; to establish appropriate safety and health practices, and determine the applicability of regulatory limitations prior to use.*

## 2. Referenced Documents

### 2.1 ASTM Standards:

B880 Specification for General Requirements for Chemical Check Analysis Limits for Nickel, Nickel Alloys and Cobalt Alloys

E8 Test Methods for Tension Testing of Metallic Materials

E29 Practice for Using Significant Digits in Test Data to Determine Conformance with Specifications

E1473 Test Methods for Chemical Analysis of Nickel, Cobalt and High-Temperature Alloys

## 3. Terminology

### 3.1 Definitions of Terms Specific to This Standard:

3.1.1 *rod, n*—a product of round solid section furnished in straight lengths.

## 4. Ordering Information

4.1 It is the responsibility of the purchaser to specify all requirements that are necessary for the safe and satisfactory performance of material ordered under this specification. Examples of such requirements include but are not limited to the following:

4.1.1 *Dimensions*—Nominal diameter and length. The shortest usable multiple length shall be specified (Table 1).

4.1.2 *Certification*—State if certification or a report of test results is required (Section 15).

4.1.3 *Purchaser Inspection*—State which tests or inspections are to be witnessed (Section 13).

4.1.4 *Samples for Product (Check) Analysis*—State whether samples shall be furnished (9.2.2).

## 5. Chemical Composition

5.1 The material shall conform to the requirements as to chemical composition prescribed in Table 2.

5.2 If a product (check) analysis is made by the purchaser, the material shall conform to the requirements specified in Table 2 subject to the permissible tolerances in Specification B880.

## 6. Mechanical Properties and Other Requirements

6.1 The mechanical properties of the material at room temperature shall conform to those shown in Table 3.

## 7. Dimensions and Permissible Variations

7.1 *Diameter*—The permissible variations from the specified diameter shall be as prescribed in Table 4.

**TABLE 1 Permissible Variations in Length of Rods**

Random mill lengths	2 to 12 ft (610 to 3660 mm) long with not more than 25 weight % under 4 ft (1.22 m).
Multiple lengths	Furnished in multiples of a specified unit length, within the length limits indicated above. For each multiple, an allowance of ¼ in. (6.35 mm) shall be made for cutting, unless otherwise specified. At the manufacturer's option, individual specified unit lengths may be furnished.
Nominal lengths	Specified nominal lengths having a range of not less than 2 ft (610 mm) with no short lengths allowed.
Cut lengths	A specified length to which all rods shall be cut with a permissible variation of + ⅛ in. (3.17 mm) – 0.

**TABLE 2 Chemical Requirements**

Element	Composition, %	
	UNS N10242	UNS N10003
Chromium	7.0-9.0	6.0-8.0
Iron, max	2.0	5.0
Carbon	0.03 max	0.04-0.08
Silicon, max	0.80	1.00
Cobalt, max	1.00	0.20
Manganese, max	0.80	1.00
Tungsten, max	...	0.50
Vanadium, max	...	0.50
Molybdenum	24.0-26.0	15.0-18.0
Phosphorus, max	0.030	0.015
Sulfur, max	0.015	0.020
Aluminum plus titanium, max	...	0.50
Copper, max	0.50	0.35
Boron, max	0.006	0.010
Nickel	remainder	remainder
Aluminum, max	0.50	...

**TABLE 3 Mechanical Property Requirements**

UNS	Tensile Strength, min, ksi (MPa)	Yield Strength (0.2 % Offset), min, ksi (MPa)	Elongation in 2 in. (50.8 mm) or 4D <sup>A</sup> , min, %
N10003	100 000(690)	40 000(280)	35
N10242	105 000(725)	45 000(310)	40

<sup>A</sup> 4D— D refers to the diameter of the tension specimen.

7.2 *Out-of-Roundness*—The permissible variation in roundness shall be as prescribed in Table 4.

7.3 *Machining Allowances*—When the surfaces of finished material are to be machined, the following allowances are suggested for normal machining operations:

7.3.1 *As-finished (Annealed and Descaled)*—For diameters of 5/16 to 1 1/16 in. (7.94 to 17.46 mm) incl, an allowance of 1/16 in. (1.59 mm) on the diameter should be made for finish machining.

#### 7.4 Length:

7.4.1 Unless multiple, nominal, or cut lengths are specified, random mill lengths shall be furnished.

7.4.2 The permissible variations in length of multiple, nominal, or cut length rod shall be as prescribed in Table 1. Where rods are ordered in multiple lengths, ¼ in. (6.35 mm) length addition shall be allowed for each uncut multiple length.

#### 7.5 Ends:

7.5.1 Rods ordered to random or nominal lengths shall be furnished with either cropped or sawed ends.

7.5.2 Rods ordered to cut lengths shall be furnished with square saw cut or machined ends.

7.6 *Weight*—For calculation of mass or weight, the following densities shall be used:

Alloy	lb/in <sup>3</sup>	g/cm <sup>3</sup>
N10003	0.317	8.78
N10242	0.327	9.05

7.7 *Straightness*—The maximum curvature (depth of chord) shall not exceed 0.050 in. multiplied by the length of the chord in feet (0.04 mm multiplied by the length in centimetres).

## 8. Workmanship, Finish, and Appearance

8.1 The material shall be uniform in quality and condition, smooth, and free of injurious imperfections.

## 9. Sampling

9.1 *Lots for Chemical Analysis and Mechanical Testing:*

9.1.1 A lot for chemical analysis shall consist of one heat.

9.1.2 A lot of bar for mechanical testing shall be defined as the material from one heat in the same condition and specified diameter.

9.2 *Sampling for Chemical Analysis:*

9.2.1 A representative sample shall be obtained from each heat during pouring or subsequent processing.

9.2.2 Product (check) analysis shall be wholly the responsibility of the purchaser.

9.3 *Sampling for Mechanical Testing*—A representative sample shall be taken from each lot of finished material.

## 10. Number of Tests and Retests

10.1 *Chemical Analysis*—One test per heat.

10.2 *Tension Tests*—One test per lot.

10.3 *Retests*—If the specimen used in the mechanical test of any lot fails to meet the specified requirements, two additional specimens shall be taken from different sample pieces and tested. The results of the tests on both of these specimens shall meet the specified requirements.

## 11. Specimen Preparation

11.1 Tension test specimens shall be taken from material after final heat-treatment and tested in the direction of fabrication.

11.2 Tension test specimens shall be any of the standard or subsized specimens shown in Test Methods E8.

11.3 In the event of disagreement, the referee specimen shall be the largest possible round specimen shown in Test Methods E8.

## 12. Test Methods

12.1 The chemical composition and mechanical properties of the material as enumerated in this specification shall be determined, in case of disagreement, in accordance with the following ASTM methods:

12.1.1 *Chemical Analysis*—Test Methods E1473.

12.1.2 *Tension Test*—Test Methods E8.

12.1.3 *Determining Significant Places*—Practice E29.

TABLE 4 Permissible Variations in Diameter and Out-of-Roundness of Finished Rods

Specified Diameter, in. (mm)	Permissible Variations, in. (mm)		
	Diameter		Out of Roundness, max
	Plus	Minus	
Hot-Finished, Annealed, and Descaled Rods			
$\frac{5}{16}$ to $\frac{7}{16}$ (7.94 to 11.11), incl	0.012 (0.30)	0.012 (0.30)	0.018 (0.46)
Over $\frac{7}{16}$ to $\frac{5}{8}$ (11.11 to 15.87), incl	0.014 (0.36)	0.014 (0.36)	0.020 (0.51)
Over $\frac{5}{8}$ to $\frac{3}{4}$ (15.87 to 19.05), excl	0.016 (0.41)	0.016 (0.41)	0.024 (0.61)
Hot-Finished, Annealed, and Ground or Turned Rods			
$\frac{3}{4}$ to $3\frac{1}{2}$ (19.05–88.9), incl	0.010 (0.25)	0	0.008 (0.20)

12.2 For purposes of determining compliance with the limits in this specification, an observed value or a calculated value shall be rounded in accordance with the rounding method of Practice E29:

Requirements	Rounded Unit for Observed or Calculated Value
Chemical composition and tolerance	nearest unit in the last right-hand place of figures of the specified limit
Tensile strength and yield strength	nearest 1000 psi (7 MPa)
Elongation	nearest 1 %

### 13. Inspection

13.1 Inspection of the material shall be made as agreed upon between the manufacturer and the purchaser as part of the purchase contract.

### 14. Rejection and Rehearing

14.1 Material tested by the purchaser that fails to conform to the requirements of this specification may be rejected. Rejection should be reported to the producer or supplier promptly and in writing. In case of dissatisfaction with the results of the test, the producer or supplier may make claim for a rehearing.

### 15. Certification

15.1 A manufacturer's certification shall be furnished to the purchaser stating that material has been manufactured, tested, and inspected in accordance with this specification, and that the test results on representative samples meet specification requirements. A report of the test results shall be furnished.

### 16. Product Marking

16.1 Each piece of material  $\frac{1}{2}$  in. (12.7 mm) and over in diameter shall be marked with this specification number, name of the material, and size of the product.

16.2 Each bundle or shipping container shall be marked with the name of the material; this specification number; the size; gross, tare, and net weight; consignor and consignee address; contract or order number; and such other information as may be defined in the contract or order.

### 17. Keywords

17.1 rod; UNS N10003; UNS N10242

## APPENDIX

(Nonmandatory Information)

### X1. HEAT TREATMENT

X1.1 Proper heat treatment during or subsequent to fabrication is necessary for optimum performance, and the manufacturer shall be consulted for details.

**SPECIFICATION FOR LOW-CARBON NICKEL-  
CHROMIUM-MOLYBDENUM, LOW-CARBON NICKEL-  
MOLYBDENUM-CHROMIUM, LOW-CARBON NICKEL-  
MOLYBDENUM-CHROMIUM-TANTALUM,  
LOW-CARBON NICKEL-CHROMIUM-  
MOLYBDENUM-COPPER, AND LOW-CARBON NICKEL-  
CHROMIUM-MOLYBDENUM-TUNGSTEN ALLOY ROD**



**SB-574**

(Identical with ASTM Specification B574-17 except that certification and test reports have been made mandatory.)

# Specification for Low-Carbon Nickel-Chromium-Molybdenum, Low-Carbon Nickel-Molybdenum-Chromium, Low-Carbon Nickel- Molybdenum-Chromium-Tantalum, Low-Carbon Nickel- Chromium-Molybdenum-Copper, and Low-Carbon Nickel- Chromium-Molybdenum-Tungsten Alloy Rod

## 1. Scope

1.1 This specification covers rod of low-carbon nickel-chromium-molybdenum alloys (UNS N10276, N06022, N06035, N06044, N06455, N06058, and N06059), low-carbon nickel-molybdenum-chromium (UNS N10362), low-carbon nickel-molybdenum-chromium-tantalum (UNS N06210), low-carbon nickel-chromium-molybdenum-copper alloy (UNS N06200), and low-carbon nickel-chromium-molybdenum-tungsten (UNS N06686) as shown in Table 1, for use in general corrosive service.

1.2 The following products are covered under this specification:

1.2.1 Rods  $\frac{5}{16}$  to  $\frac{3}{4}$  in. (7.94 to 19.05 mm), exclusive, in diameter, hot or cold finished, solution annealed and pickled, or mechanically descaled.

1.2.2 Rods  $\frac{3}{4}$  to  $3\frac{1}{2}$  in. (19.05 to 88.9 mm), inclusive, in diameter, hot or cold finished, solution annealed, ground or turned.

1.2.3 Rods  $\frac{1}{4}$  to  $3\frac{1}{2}$  in. (6.35 to 88.9 mm), inclusive, in diameter, solution annealed, cold finished, as cold finished, ground or turned (N06059 and N06686 only, see Table 2 and Table 3).

1.3 The values stated in inch-pound units are to be regarded as standard. The values given in parentheses are mathematical conversions to SI units that are provided for information only and are not considered standard.

1.4 *This standard does not purport to address all of the safety concerns, if any, associated with its use. It is the*

*responsibility of the user of this standard to become familiar with all hazards including those identified in the appropriate Safety Data Sheet (SDS) for this product/material as provided by the manufacturer, to establish appropriate safety and health practices, and determine the applicability of regulatory limitations prior to use.*

1.5 *This international standard was developed in accordance with internationally recognized principles on standardization established in the Decision on Principles for the Development of International Standards, Guides and Recommendations issued by the World Trade Organization Technical Barriers to Trade (TBT) Committee.*

## 2. Referenced Documents

### 2.1 ASTM Standards:

B880 Specification for General Requirements for Chemical Check Analysis Limits for Nickel, Nickel Alloys and Cobalt Alloys

E8 Test Methods for Tension Testing of Metallic Materials  
E29 Practice for Using Significant Digits in Test Data to Determine Conformance with Specifications

E55 Practice for Sampling Wrought Nonferrous Metals and Alloys for Determination of Chemical Composition

E527 Practice for Numbering Metals and Alloys in the Unified Numbering System (UNS)

E1473 Test Methods for Chemical Analysis of Nickel, Cobalt and High-Temperature Alloys

## 3. Terminology

### 3.1 Definitions of Terms Specific to This Standard:

3.1.1 *rod, n*—a product of round solid section furnished in straight lengths.

ASME BPVC Section II part B) 2025

ASME BPVC II B (ASME BPVC Section II part B) 2025

ASME BPVC.II.B-2025

867

SB-574

**TABLE 1 Chemical Requirements**

Element	Composition Limits, %										
	Alloy N06035	Alloy N06044	Alloy N10276	Alloy N06022	Alloy N06455	Alloy N06059	Alloy N06058	Alloy N06200	Alloy N10362	Alloy N06210	Alloy N06686
Molybdenum	7.60–9.00	0.80-1.20	15.0–17.0	12.5–14.5	14.0–17.0	15.0–16.5	18.5–21.0	15.0–17.0	21.5-23.0	18.0–20.0	15.0-17.0
Chromium	32.25–34.25	43.5-45.3	14.5–16.5	20.0–22.5	14.0–18.0	22.0–24.0	20.0- 23.0	22.0–24.0	13.8-15.6	18.0–20.0	19.0-23.0
Iron	2.00 max	0.3 max	4.0–7.0	2.0–6.0	3.0 max	1.5, max	1.5, max	3.0 max	1.25 max	1.0 max	5.0 max
Tungsten	0.60 max	...	3.0–4.5	2.5–3.5	...	...	0.3 max	...	...	...	3.0-4.4
Cobalt, max	1.00	...	2.5	2.5	2.0	0.3	0.3 max	2.0 max	...	1.0	...
Carbon, max	0.050	0.02	0.010	0.015	0.015	0.010	0.010	0.010	0.010	0.015	0.010
Silicon, max	0.60	0.20	0.08	0.08	0.08	0.10	0.10	0.08	0.08	0.08	0.08
Manganese, max	0.50	0.07-0.30	1.0	0.50	1.0	0.5	0.5	0.5	0.60	0.5	0.75
Vanadium, max	0.20	...	0.35	0.35	...	...	...	...	...	0.35	...
Phosphorus, max	0.030	0.020	0.04	0.02	0.04	0.015	0.015	0.025	0.025	0.02	0.04
Sulfur, max	0.015	0.020	0.03	0.02	0.03	0.010	0.010	0.010	0.010	0.02	0.02
Titanium	...	0.10-0.30	...	...	0.7 max	...	...	...	...	...	0.02-0.25
Nickel	remainder <sup>A</sup>	Bal	remainder <sup>A</sup>	remainder <sup>A</sup>	remainder <sup>A</sup>	Bal	Bal	remainder <sup>A</sup>	remainder <sup>A</sup>	remainder <sup>A</sup>	remainder <sup>A</sup>
Aluminum	0.40 max	0.30 max	...	...	...	0.1–0.4	0.40 max	0.50 max	0.50 max	...	...
Copper	0.30 max	...	...	...	...	0.50 max	0.50 max	1.3–1.9	...	...	...
Tantalum	...	...	...	...	...	...	...	...	...	1.5–2.2	...
Nitrogen	...	...	...	...	...	...	0.02–0.15	...	...	...	...

<sup>A</sup> See 12.1.1.

**TABLE 2 Permissible Variations in Diameter and Out-of-Roundness of As Cold Finished Rods**

Specified Diameter, in. (mm)	Permissible Variations, in. (mm)		
	Diameter		Out of Roundness, max
	+	-	
1/4 -7/16 (6.35-11.11), incl	0.012 (0.30)	0.012 (0.30)	0.018 (0.46)
Over 7/16 -5/8 (11.11-15.87), incl	0.014 (0.36)	0.014 (0.36)	0.020 (0.51)
Over 5/8 -3/4 (15.87-19.05), excl	0.016 (0.41)	0.016 (0.41)	0.024 (0.61)
3/4 -3 1/2 (19.05-88.9), incl	0.010 (0.25)	0.010 (0.25)	0.010 (0.25)

**TABLE 3 Mechanical Property Requirements for As Cold Finished Rods**

Alloy	Grade	Tensile Strength, min, psi (MPa)	Yield Strength (0.2 % Offset), min, psi (MPa)	Elongation in 2 in. (50.8 mm) or 4D <sup>A</sup> min, %
N06059	1	120 (827)	85 (586)	20
	2	135 (931)	125 (862)	20
	3	160 (1103)	150 (1034)	15
N06686	1	120 (827)	85 (586)	20
	2	135 (931)	125 (862)	20
	3	160 (1103)	150 (1034)	20

<sup>A</sup> D refers to the diameter of the tension specimen.

**TABLE 4 Permissible Variations in Diameter and Out-of-Roundness of Hot or Cold Finished, Solution Annealed Rods**

Specified Diameter, in. (mm)	Permissible Variations, in. (mm)		
	Diameter		Out of Roundness, max
	+	-	
5/16 Hot-Finished, Annealed, and Descaled Rods			
5/16 -7/16 (7.94-11.11), incl	0.012 (0.30)	0.012 (0.30)	0.018 (0.46)
Over 7/16 -5/8 (11.11-15.87), incl	0.014 (0.36)	0.014 (0.36)	0.020 (0.51)
Over 5/8 -3/4 (15.87-19.05), excl	0.016 (0.41)	0.016 (0.41)	0.024 (0.61)
Hot-Finished, Annealed, and Ground or Turned Rods			
3/4 -3 1/2 (19.05-88.9), incl	0.010 (0.25)	0	0.008 (0.20)

**TABLE 5 Mechanical Property Requirements for Hot or Cold Finished, Solution Annealed Rods**

Alloy	Tensile Strength, min, psi (MPa)	Yield Strength (0.2 % Offset), min, psi (MPa)	Elongation in 2 in. (50.8 mm) or 4D <sup>A</sup> min, %
N10276	100 000 (690)	41 000 (283)	40
N06022	100 000 (690)	45 000 (310)	45
N06035	85 000 (586)	35 000 (241)	30
N06044	100 000 (690)	45 000 (310)	30
N06455	100 000 (690)	40 000 (276)	40
N06058	110 000 (760)	52 000 (360)	40
N06059	100 000 (690)	45 000 (310)	45
N06200	100 000 (690)	45 000 (310)	45
N10362	105 000 (725)	45 000 (310)	40
N06686	100 000 (690)	45 000 (310)	45
N06210	100 000 (690)	45 000 (310)	45

<sup>A</sup> D refers to the diameter of the tension specimen.

**4. Ordering Information**

4.1 It is the responsibility of the purchaser to specify all requirements that are necessary for material ordered under this specification. Examples of such requirements include, but are not limited to the following:

4.1.1 *Alloy*—Table 1.

4.1.2 *Dimensions*—Nominal diameter and length. The shortest usable multiple length should be specified (Table 4).

4.1.3 *Certification*—Certification and a report of test results are required (Section 15).

4.1.4 *Purchaser Inspection*—State which tests or inspections are to be witnessed (Section 13).

4.1.5 *Samples for Product (Check) Analysis*—State whether samples should be furnished (9.2.2).

**5. Chemical Composition**

5.1 The material shall conform to the composition limits specified in Table 1.

5.2 If a product (check) analysis is made by the purchaser, the material shall conform to the product (check) analysis variations per Specification B880.

## 6. Mechanical Properties and Other Requirements

6.1 The mechanical properties of the material at room temperature shall conform to those shown in Table 3 and Table 5.

## 7. Dimensions and Permissible Variations

7.1 *Diameter*—The permissible variations from the specified diameter shall be as prescribed in Table 2 and Table 4.

7.2 *Out of Roundness*—The permissible variation in roundness shall be as prescribed in Table 2 and Table 4.

7.3 *Machining Allowances*—When the surfaces of finished material are to be machined, the following allowances are suggested for normal machining operations.

7.3.1 *As-finished (Annealed and Descaled)*—For diameters of  $\frac{5}{16}$  to  $\frac{11}{16}$  in. (7.94 to 17.46 mm) inclusive, an allowance of  $\frac{1}{16}$  in. (1.59 mm) on the diameter should be made for finish machining.

### 7.4 Length:

7.4.1 Unless multiple, nominal, or cut lengths are specified, random mill lengths shall be furnished.

7.4.2 The permissible variations in length of multiple, nominal, or cut length rod shall be as prescribed in Table 6. Where rods are ordered in multiple lengths, a  $\frac{1}{4}$ -in. (6.35-mm) length addition shall be allowed for each uncut multiple length.

### 7.5 Ends:

7.5.1 Rods ordered to random or nominal lengths shall be furnished with either cropped or sawed ends.

7.5.2 Rods ordered to cut lengths shall be furnished with square sawcut or machined ends.

7.6 *Weight*—For calculations of mass or weight, the following densities shall be used:

Alloy	Density	
	lb/in. <sup>3</sup>	g/cm <sup>3</sup>
N10276	0.321	8.87
N06022	0.314	8.69
N06035	0.296	8.18
N06044	0.287	7.97
N06455	0.312	8.64
N06058	0.318	8.80
N06059	0.311	8.60
N06200	0.307	8.50
N10362	0.319	8.83
N06686	0.315	8.73
N06210	0.316	8.76

TABLE 6 Permissible Variations in Length of Rods

Random mill lengths	2 to 12 ft (610 to 3660 mm) long with not more than 25 weight % under 4 ft (1.22 m).
Multiple lengths	Furnished in multiples of a specified unit length, within the length limits indicated above. For each multiple, an allowance of $\frac{1}{4}$ in. (6.35 mm) shall be made for cutting, unless otherwise specified. At the manufacturer's option, individual specified unit lengths may be furnished.
Nominal lengths	Specified nominal lengths having a range of not less than 2 ft (610 mm) with no short lengths allowed.
Cut lengths	A specified length to which all rods shall be cut with a permissible variation of $\pm\frac{1}{8}$ in. (3.17 mm) – 0.

7.7 *Straightness*—The maximum curvature (depth of chord) shall not exceed 0.050 in. multiplied by the length of the chord in feet (0.04 mm multiplied by the length in centimetres).

## 8. Workmanship, Finish, and Appearance

8.1 The material shall be uniform in quality and condition, smooth, and free of injurious imperfections.

## 9. Sampling

### 9.1 Lots for Chemical Analysis and Mechanical Testing:

9.1.1 A lot for chemical analysis shall consist of one heat.

9.1.2 A lot of bar for mechanical testing shall be defined as the material from one heat in the same condition and specified diameter.

### 9.2 Sampling for Chemical Analysis:

9.2.1 A representative sample shall be obtained from each heat during pouring or subsequent processing.

9.2.2 Product (check) analysis shall be wholly the responsibility of the purchaser.

9.3 *Sampling for Mechanical Testing*—A representative sample shall be taken from each lot of finished material.

## 10. Number of Tests and Retests

10.1 *Chemical Analysis*—One test per heat.

10.2 *Tension Tests*—One test per lot.

10.3 *Retests*—If the specimen used in the mechanical test of any lot fails to meet the specified requirements, two additional specimens shall be taken from different sample pieces and tested. The results of the tests on both of these specimens shall meet the specified requirements.

## 11. Specimen Preparation

11.1 Tension test specimens shall be taken from material after final heat-treatment and tested in the direction of fabrication.

11.2 Tension test specimens shall be any of the standard or subsized specimens shown in Test Methods E8.

11.3 In the event of disagreement, the referee specimen shall be the largest possible round specimen shown in Test Methods E8.

## 12. Test Methods

12.1 The chemical composition and mechanical properties of the material as enumerated in this specification shall be determined, in case of disagreement, in accordance with the following ASTM methods:

12.1.1 *Chemical Analysis*—Test Methods E1473, For elements not covered by Test Methods E1473, the referee method shall be as agreed upon between the manufacturer and the purchaser. The nickel composition shall be determined arithmetically by difference.

12.1.2 *Tension Test*—Test Methods E8.

12.1.3 *Method of Sampling*—Practice E55.

12.1.4 *Determining Significant Places*—Practice E29.

12.2 For purposes of determining compliance with the limits in this specification, an observed value or a calculated value shall be rounded in accordance with the rounding method of Practice E29:

Requirements	Rounded Unit for Observed or Calculated Value
Chemical composition and tolerances	nearest unit in the last right-hand place of figures of the specified limit
Tensile strength and yield strength	nearest 1000 psi (7 MPa)
Elongation	nearest 1 %

### 13. Inspection

13.1 Inspection of the material shall be made as agreed upon by the manufacturer and the purchaser as part of the purchase contract.

### 14. Rejection and Rehearing

14.1 Material that fails to conform to the requirements of this specification may be rejected. Rejection should be reported to the producer or supplier promptly and in writing. In case of dissatisfaction with the results of the test, the producer or supplier may make claim for a rehearing.

### 15. Certification

15.1 A manufacturer's certification shall be furnished to the

purchaser stating that material has been manufactured, tested, and inspected in accordance with this specification, and that the test results on representative samples meet specification requirements. A report of the test results shall be furnished.

### 16. Product Marking

16.1 Each piece of material  $\frac{1}{2}$  in. (12.7 mm) and over in diameter shall be marked with the specification number, alloy, heat number, manufacturer's identification, and size. The markings shall have no deleterious effect on the material or its performance and shall be sufficiently stable to withstand normal handling.

16.2 Each bundle or shipping container shall be marked with the name of the material; this specification number; alloy; the size; gross, tare and net weight; consignor and consignee address; contract or order number; and such other information as may be defined in the contract or order.

### 17. Keywords

17.1 N06022; N06035; N06044; N06058; N06059; N06200; N06210; N06455; N06686; N10276; N10362; rod

## APPENDIX

(Nonmandatory Information)

### X1. HEAT TREATMENT

X1.1 Proper heat treatment during or subsequent to fabrication is necessary for optimum performance and the manufacturer shall be consulted for details.

**SPECIFICATION FOR LOW-CARBON NICKEL-  
CHROMIUM-MOLYBDENUM, LOW-CARBON NICKEL-  
CHROMIUM-MOLYBDENUM-COPPER, LOW-CARBON  
NICKEL-CHROMIUM-MOLYBDENUM-TANTALUM,  
LOW-CARBON NICKEL-CHROMIUM-  
MOLYBDENUM-TUNGSTEN, AND LOW-CARBON  
NICKEL-MOLYBDENUM-CHROMIUM ALLOY PLATE,  
SHEET, AND STRIP**



**SB-575**

(Identical with ASTM Specification B575-17 except that certification and test reports have been made mandatory.)

# Specification for Low-Carbon Nickel-Chromium-Molybdenum, Low-Carbon Nickel-Chromium-Molybdenum-Copper, Low-Carbon Nickel- Chromium-Molybdenum-Tantalum, Low-Carbon Nickel- Chromium-Molybdenum-Tungsten, and Low-Carbon Nickel- Molybdenum-Chromium Alloy Plate, Sheet, and Strip

## 1. Scope

1.1 This specification covers plate, sheet, and strip of low-carbon nickel-chromium-molybdenum alloys (UNS N10276, N06022, N06455, N06035, N06044, UNS N06058, UNS N06059), low-carbon nickel-chromium-molybdenum-copper alloy (UNS N06200), low-carbon nickel-molybdenum-chromium (UNS N10362), low-carbon nickel-chromium-molybdenum-tantalum alloy (UNS N06210), and low-carbon nickel-chromium-molybdenum-tungsten alloy (UNS N06686) as shown in Table 1, for use in general corrosive service.

1.2 The following products are covered under this specification:

1.2.1 *Sheet and Strip*—Hot or cold rolled, solution annealed, and descaled unless solution anneal is performed in an atmosphere yielding a bright finish.

1.2.2 *Plate*—Hot or cold rolled, solution annealed, and descaled.

1.3 The values stated in inch-pound units are to be regarded as standard. The values given in parentheses are mathematical conversions to SI units that are provided for information only and are not considered standard.

1.4 *This standard does not purport to address all of the safety concerns, if any, associated with its use. It is the responsibility of the user of this standard to become familiar with all hazards including those identified in the appropriate Safety Data Sheet (SDS) for this product/material as provided*

*by the manufacturer, to establish appropriate safety and health practices, and determine the applicability of regulatory limitations prior to use.*

1.5 *This international standard was developed in accordance with internationally recognized principles on standardization established in the Decision on Principles for the Development of International Standards, Guides and Recommendations issued by the World Trade Organization Technical Barriers to Trade (TBT) Committee.*

## 2. Referenced Documents

### 2.1 ASTM Standards:

B906 Specification for General Requirements for Flat-Rolled Nickel and Nickel Alloys Plate, Sheet, and Strip

E112 Test Methods for Determining Average Grain Size

E140 Hardness Conversion Tables for Metals Relationship Among Brinell Hardness, Vickers Hardness, Rockwell Hardness, Superficial Hardness, Knoop Hardness, Scleroscope Hardness, and Leeb Hardness

E527 Practice for Numbering Metals and Alloys in the Unified Numbering System (UNS)

## 3. Terminology

### 3.1 Definitions of Terms Specific to This Standard:

3.1.1 *cold-rolled plate, n*—material  $\frac{3}{16}$  to  $\frac{3}{8}$  in. (4.76 to 9.52 mm), inclusive, in thickness.

3.1.2 *hot-rolled plate, n*—material  $\frac{3}{16}$  in. (4.76 mm) and over in thickness.

3.1.3 *plate, n*—material  $\frac{3}{16}$  in. (4.76 mm) and over in thickness.

3.1.4 *sheet and strip, n*—material under  $\frac{3}{16}$  in. (4.76 mm) in thickness.

ASME NORMATIVES : Click to view the full PDF of ASME BPVC.II.B

**TABLE 1 Chemical Requirements**

Element	Composition Limits, %										
	Alloy N06035	Alloy N06044	Alloy N10276	Alloy N06022	Alloy N06455	Alloy N06059	Alloy N06058	Alloy N06200	Alloy N06210	Alloy N10362	Alloy N06686
Molybdenum	7.60–9.00	0.80-1.20	15.0–17.0	12.5–14.5	14.0–17.0	15.0–16.5	18.5–21.0	15.0–17.0	18.0–20.0	21.5–23.0	15.0-17.0
Chromium	32.25–34.25	43.5-45.3	14.5–16.5	20.0–22.5	14.0–18.0	22.0–24.0	20.0–23.0	22.0–24.0	18.0–20.0	13.8–15.6	19.0-23.0
Iron	2.00 max	0.3 max	4.0–7.0	2.0–6.0	3.0 max	1.5, max	1.5, max	3.0 max	1.0 max	1.25 max	5.0 max
Tungsten	0.60 max	...	3.0–4.5	2.5–3.5	...	...	0.3 max	...	...	...	3.0-4.4
Cobalt, max	1.00	...	2.5	2.5	2.0	0.3	0.3	2.0 max	1.0	...	...
Carbon, max	0.050	0.02	0.010	0.015	0.015	0.010	0.010	0.010	0.015	0.010	0.010
Silicon, max	0.60	0.20	0.08	0.08	0.08	0.10	0.10	0.08	0.08	0.08	0.08
Manganese, max	0.50	0.07-0.30	1.0	0.50	1.0	0.5	0.5	0.50	0.5	0.60	0.75
Vanadium, max	0.20	...	0.35	0.35	...	...	...	...	0.35	...	...
Phosphorus, max	0.030	0.020	0.04	0.02	0.04	0.015	0.015	0.025	0.02	0.025	0.04
Sulfur, max	0.015	0.020	0.03	0.02	0.03	0.010	0.010	0.010	0.02	0.010	0.02
Titanium	...	0.10-0.30	...	...	0.7 max	...	...	...	...	...	0.02-0.25
Nickel	remainder <sup>A</sup>	Bal	remainder <sup>A</sup>	remainder <sup>A</sup>	remainder <sup>A</sup>	Bal	Bal	remainder <sup>A</sup>	remainder <sup>A</sup>	remainder <sup>A</sup>	remainder <sup>A</sup>
Aluminum	0.40 max	0.30 max	...	...	...	0.1–0.4	0.40 max	0.50 max	...	0.50 max	...
Copper	0.30 max	...	...	...	...	0.50 max	0.50 max	1.3–1.9	...	...	...
Tantalum	...	...	...	...	...	...	...	...	1.5–2.2	...	...
Nitrogen	...	...	...	...	...	...	0.02–0.15	...	...	...	...

<sup>A</sup> Shall be determined arithmetically by difference.

(ASME BPVC Section II part B) 2025

TABLE 2 Mechanical Property Requirements

Alloy	Tensile Strength, min, psi (MPa)	Yield Strength (0.2 % Offset), min, psi (MPa)	Elongation in 2 in. (50.8 mm) or 4D <sup>A</sup> min, %	Rockwell Hardness, <sup>B</sup> max
N10276	100 000 (690)	41 000 (283)	40	100 HRB
N06022	100 000 (690)	45 000 (310)	45	100 HRB
N06455	100 000 (690)	40 000 (276)	40	100 HRB
N06035	85 000 (586)	35 000 (241)	30	100 HRB
N06044	100 000 (690)	45 000 (310)	30	100 HRB
N06058	110 000 (760)	52 000 (360)	40	100 HRB
N06059	100 000 (690)	45 000 (310)	45	100 HRB
N06200	100 000 (690)	45 000 (310)	45	100 HRB
N10362	105 000 (725)	45 000 (310)	40	100 HRB
N06686	100 000 (690)	45 000 (310)	45	100 HRB
N06210	100 000 (690)	45 000 (310)	45	100 HRB

<sup>A</sup> D refers to the diameter of the tension specimen.

<sup>B</sup> Hardness values are shown for information purposes only and are not to be used as a basis of acceptance or rejection. For approximate hardness conversions, see Hardness Conversion Tables E140.

#### 4. General Requirements

4.1 Material furnished to this specification shall conform to the applicable requirements of Specification B906 unless otherwise provided herein.

#### 5. Ordering Information

5.1 It is the responsibility of the purchaser to specify all requirements that are necessary for material ordered under this specification. Examples of such requirements include, but are not limited to the following:

5.1.1 *Alloy*—Table 1,

5.1.2 *Dimensions*—Thickness (in decimals of an inch), width, and length (inch or fractions of an inch),

5.1.3 *Optional Requirement*—Plate; state how plate is to be cut (Specification B906, table titled Permissible Variations in Width and Length of Sheared, Torch-Cut, or Abrasive-Cut Rectangular Plate),

5.1.4 *Certification*—Certification and a report of test results is required (Specification B906, section on Material Test Report and Certification),

5.1.5 *Purchase Inspection*—State which tests or inspections are to be witnessed (Specification B906, section on Inspection), and

5.1.6 *Samples for Product (Check) Analysis*—State whether samples should be furnished (Specification B906, section on Sampling).

#### 6. Chemical Composition

6.1 The material shall conform to the composition limits specified in Table 1.

6.2 If a product (check) analysis is made by the purchaser, the material shall conform to the requirements specified in Table 1 and Specification B906.

#### 7. Mechanical Properties and Other Requirements

7.1 *Tensile Properties*—The material shall conform to the room temperature tensile properties prescribed in Table 2.

7.2 *Hardness*—The hardness values given in Table 2 are informative only.

7.3 *Grain Size for Sheet and Strip*—Sheet and strip shall conform to the grain sizes as illustrated in Plate 1 of Test Methods E112. The requirements shall be as indicated in Table 3.

#### 8. Dimensions, Mass, and Permissible Variations

8.1 *Weight*—For calculations of mass or weight, the following densities shall be used:

Alloy	Density	
	lb/in. <sup>3</sup>	g/cm <sup>3</sup>
N10276	0.321	(8.87)
N06022	0.314	(8.69)
N06455	0.312	(8.64)
N06035	0.296	(8.18)
N06044	0.287	(7.97)
N06058	0.318	(8.80)
N06059	0.311	(8.60)
N06200	0.307	(8.50)
N06210	0.316	(8.76)
N10362	0.319	(8.83)
N06686	0.315	(8.73)

8.2 *Thickness*:

8.2.1 *Plate*—The permissible variations in thickness of plate shall be as prescribed in Specification B906, table titled Permissible Variations in Thickness of Plate.

8.2.2 *Sheet and Strip*—The permissible variations in thickness of sheet and strip shall be as prescribed in Specification B906, table titled Permissible Variations in thickness of Sheet and Strip. The thickness shall be measured with the micrometer spindle  $\frac{3}{8}$  in. (9.525 mm) or more from any edge for material 1 in. (25.4 mm) or over in width and at any place on material under 1 in. (25.4 mm) in width.

8.3 *Width*:

8.3.1 *Plate*—The permissible variations in width of rectangular plates shall be as prescribed in Specification B906, table

TABLE 3 Grain Size for Annealed Sheet

Thickness, in. (mm)	ASTM Micrograin Size Number	Average Grain Diameter, mm (in.)
0.125 (3.175) and under	3.0 or finer	0.127 (0.0050)
Over 0.125 (3.175)	1.5 or finer	0.214 (0.0084)

titled Permissible Variations in Width and Length of Sheared, Torch-Cut, or Abrasive-Cut Rectangular Plate.

8.3.2 *Sheet and Strip*—The permissible variations in width for sheet and strip shall be as prescribed in Specification B906, table titled Permissible Variations in width of Sheet and Strip.

8.4 *Length*:

8.4.1 *Plate*—Permissible variations in the length of rectangular plate shall be as prescribed in Specification B906, table titled Permissible Variations in Width and Length of Sheared, Torch-Cut, or Abrasive-Cut Rectangular Plate.

8.4.2 *Sheet and Strip*—Sheet and strip may be ordered to cut lengths, in which case a variation of  $\frac{1}{8}$  in. (3.175 mm) over the specified length shall be permitted, with a 0 minus tolerance.

8.5 *Straightness*:

8.5.1 The edgewise curvature (depth of chord) of flat sheet, strip, and plate shall not exceed 0.05 in. (1.27 mm) multiplied by the length in feet or 0.04 mm multiplied by the length in centimetres.

8.5.2 Straightness for coiled strip is subject to agreement between the manufacturer and the purchaser.

8.6 *Squareness* (Sheet)—For sheets of all thicknesses and widths of 6 in. (152.4 mm) or more, the angle between adjacent sides shall be  $90 \pm 0.15^\circ$  ( $\frac{1}{16}$  in. in 24 in. of 2.6 mm/m).

8.7 *Flatness*—Plate, sheet, and strip shall be commercially flat.

8.8 *Edges*:

8.8.1 Plates shall have sheared or cut (machined, abrasive cut, powder cut, or inert arc cut) edges, as specified.

8.8.2 Sheet and strip shall have sheared or slit edges.

## 9. Product Marking

9.1 Each plate, sheet, or strip shall be marked on one face with the specification number, alloy, heat number, manufacturer's identification, and size. The markings shall have no deleterious effect on the material or its performance and shall be sufficiently stable to withstand normal handling.

9.2 Each bundle or shipping container shall be marked with the name of the material; this specification number; alloy; the size; gross, tare, and net weight; consignor and consignee address; contract or order number; and such other information as may be defined in the contract or order.

## 10. Keywords

10.1 N06022; N06035; N06044; N06058; N06059; N06200; N06210; N10362; N06455; N06686; N10276; plate; sheet; strip

## APPENDIX

(Nonmandatory Information)

### X1. HEAT TREATMENT

X1.1 Proper heat treatment during or subsequent to fabrication is necessary for optimum performance, and the manufacturer shall be consulted for details.

ASMENORMDOC.COM : Click to view the full PDF of ASME BPVC.II.B (ASME BPVC Section II part B) 2025

INTENTIONALLY LEFT BLANK

# SPECIFICATION FOR NICKEL-CHROMIUM-IRON- MOLYBDENUM-COPPER ALLOY ROD



**SB-581**

(Identical with ASTM Specification B581-02(2008) except that certification and test reports have been made mandatory.)

# Standard Specification for Nickel-Chromium-Iron-Molybdenum-Copper Alloy Rod

## 1. Scope

1.1 This specification covers rod of Ni-Cr-Fe-Mo-Cu alloys (UNS N06007, N06975, N06985, N06030, and N08031) as shown in Tables 1-3, for use in general corrosive service.

1.2 The following products are covered under this specification:

1.2.1 Rods  $\frac{5}{16}$  to  $\frac{3}{4}$  in. (7.94 to 19.05 mm) excl in diameter, hot- or cold-finished, solution annealed and pickled or mechanically descaled.

1.2.2 Rods  $\frac{3}{4}$  to  $3\frac{1}{2}$  in. (19.05 to 88.9 mm) incl in diameter, hot- or cold-finished, solution annealed, ground or turned.

1.3 The values stated in inch-pound units are to be regarded as standard. The values given in parentheses are mathematical conversions to SI units that are provided for information only and are not considered standard.

1.4 *This standard does not purport to address all of the safety concerns, if any, associated with its use. It is the responsibility of the user of this standard to become familiar with all hazards including those identified in the appropriate Material Safety Data Sheet (MSDS) for this product/material as provided by the manufacturer, to establish appropriate safety and health practices, and determine the applicability of regulatory limitations prior to use.*

## 2. Referenced Documents

### 2.1 ASTM Standards:

B880 Specification for General Requirements for Chemical Check Analysis Limits for Nickel, Nickel Alloys and Cobalt Alloys

E8 Test Methods for Tension Testing of Metallic Materials

E29 Practice for Using Significant Digits in Test Data to Determine Conformance with Specifications

E55 Practice for Sampling Wrought Nonferrous Metals and Alloys for Determination of Chemical Composition

E1473 Test Methods for Chemical Analysis of Nickel, Cobalt, and High-Temperature Alloys

## 3. Terminology

### 3.1 Definitions of Terms Specific to This Standard:

3.1.1 *rod, n*—material of round solid section furnished in straight lengths.

## 4. Ordering Information

4.1 It is the responsibility of the purchaser to specify all requirements that are necessary for material ordered under this specification. Examples of such requirements include, but are not limited to the following:

4.1.1 *Alloy*—Table 1.

4.1.2 *Dimensions*—Nominal diameter and length. The shortest useable multiple length shall be specified (Table 4).

4.1.3 DELETED

4.1.4 *Purchaser Inspection*—State which tests or inspections are to be witnessed (Section 14).

4.1.5 *Samples for Product (Check)Analysis*—State whether samples shall be furnished (10.2.2).

## 5. Chemical Composition

5.1 *Heat Analysis*—The material shall conform to the composition limits specified in Table 1.

5.2 *Product (Check)Analysis*—If a product (check) analysis is made by the purchaser, the material shall conform to the requirements specified in Table 1 subject to the permissible tolerances in Specification B880.

## 6. Mechanical and Other Requirements

6.1 The material shall conform to the requirements of Table 2.

## 7. Straightness

7.1 The maximum curvature (depth of cord) shall not exceed 0.050 in. multiplied by the length in feet (0.04 mm multiplied by the length in centimetres).

TABLE 1 Chemical Requirements

Element	Composition Limits, %				
	Alloy N06007	Alloy N06975	Alloy N06985	Alloy N06030	Alloy N08031
Nickel	remainder <sup>A</sup>	47.0–52.0	remainder <sup>A</sup>	remainder <sup>A</sup>	30.0–32.0
Chromium	21.0–23.5	23.0–26.0	21.0–23.5	28.0–31.5	26.0–28.0
Iron	18.0–21.0	remainder <sup>A</sup>	18.0–21.0	13.0–17.0	remainder <sup>A</sup>
Molybdenum	5.5–7.5	5.0–7.0	6.0–8.0	4.0–6.0	30.-7.0
Copper	1.5–2.5	0.70–1.20	1.5–2.5	1.0–2.4	1.0–1.4
Manganese	1.0–2.0	1.0 max	1.0 max	1.5 max	2.0 max
Cobalt, max	2.5	...	5.0 max	5.0 max	...
Carbon, max	0.05	0.03	0.015 max	0.03 max	0.015
Tungsten	1.0 max	...	1.5 max	1.5–4.0	...
Silicon, max	1.0	1.0	1.0 max	0.8 max	0.3
Phosphorus, max	0.04	0.03	0.04 max	0.04 max	0.020
Sulfur, max	0.03	0.03	0.03 max	0.02 max	0.010
Columbium + tantalum	1.75–2.50	...	0.50 max	0.30–1.50	...
Titanium	...	0.7–1.5	...	...	...
Nitrogen	0.15–0.25	...	...	...	...

<sup>A</sup> See 13.1.1.

TABLE 2 Mechanical Property Requirements

Alloy	Specified Diameter, in. (mm)	Tensile Strength min, psi (MPa)	Yield Strength (0.2 % Offset), min, psi (MPa)	Elongation in 2 in. or 50.8 mm or 4D <sup>A</sup> min
N06007	5/16 to 3/4 (7.94 to 19.05), incl	90 000 (621)	35 000 (241)	35
	Over 3/4 to 3 1/2 (19.05 to 88.9), incl	85 000 (586)	30 000 (207)	30
N06975	5/16 to 3 1/2 (7.94 to 88.9), incl	85 000 (586)	32 000 (221)	40
	5/16 to 3/4 (7.9 to 19.05), incl	90 000 (621)	35 000 (241)	45
N06985	Over 3/4 to 3 1/2 (19.05 to 88.9), incl	85 000 (586)	30 000 (207)	35
	...	85 000 (586)	35 000 (241)	30
N06030	...	85 000 (586)	35 000 (241)	30
N08031	All sizes	94 000 (648)	40 000 (276)	40

<sup>A</sup> D refers to the diameter of the tension specimen.

TABLE 3 Permissible Variations in Diameter and Out-of-Roundness of Rods

Specified Diameter, in. (mm)	Permissible Variations, in. (mm)		Out-of-Roundness, max
	Diameter		
Hot-Finished, Annealed, and Descaled Rods			
5/16 to 7/16 (7.94 to 11.11), incl	+ 0.012 (0.305)	- 0.012 (0.305)	0.018 (0.457)
Over 7/16 to 5/8 (11.11 to 15.87), incl	+ 0.014 (0.355)	- 0.014 (0.355)	0.020 (0.508)
Over 5/8 to 3/4 (15.87 to 19.05), excl	+ 0.016 (0.406)	- 0.016 (0.406)	0.024 (0.610)
Hot-Finished, Annealed, and Ground or Turned Rods			
3/4 to 3 1/2 (19.05 to 88.9), incl	+ 0.010 (0.254)	- 0	0.008 (0.203)

## 8. Permissible Variations in Dimensions

8.1 *Diameter*—The permissible variations from the specified diameter and out-of-roundness shall be as prescribed in Table 3.

8.2 *Machining Allowances*—When the surfaces of finished material are to be machined, the following allowances are suggested for normal machining operations:

8.2.1 *As-Finished Rounds (Annealed and Descaled)*—For diameters of 5/16 to 1 1/16 in. (7.94 to 17.46 mm) incl, an allowance of 1/16 in. (1.59 mm) on the diameter should be made for finish machining.

8.3 *Length*—The permissible variations in length of finished rods shall be as prescribed in Table 4. Unless otherwise specified, random mill lengths shall be furnished. Rods ordered to random or nominal lengths shall be furnished with either cropped or saw-cut ends; material ordered to cut lengths shall be furnished with square saw-cut or machined ends. Where

TABLE 4 Permissible Variations in Length of Rods

Random mill lengths	2 to 12 ft (61 to 366 cm) long with not more than 25 weight % under 4 ft (122 cm).
Multiple lengths	Furnished in multiples of a specified unit length, within the length limits indicated above. For each multiple, an allowance of 1/4 in. (6.35 mm) will be made for cutting, unless otherwise specified. At the manufacturer's option, individual specified unit lengths may be furnished.
Nominal lengths	Specified nominal lengths having a range of not less than 2 ft (61 cm) with no short lengths allowed.
Cut lengths	A specified length to which all rods will be cut with a permissible variation of + 1/8 in. (3.17 mm), - 0.

rods are ordered in multiple lengths, a 1/4-in. (6.35-mm) length addition shall be allowed for each uncut multiple length.

8.4 *Weight*—For calculation of mass or weight, the following densities shall be used:

Alloy	Density	
	lb/in. <sup>3</sup>	g/cm <sup>3</sup>
N06007	0.300	8.31
N06975	0.295	8.17
N06985	0.300	8.31
N06030	0.297	8.22
N08031	0.293	8.10

## 9. Workmanship, Finish, and Appearance

9.1 The material shall be uniform in quality and condition, smooth, commercially straight, and free of injurious imperfections.

## 10. Sampling

### 10.1 Lots for Chemical Analysis and Mechanical Testing:

10.1.1 A lot for chemical analysis shall consist of one heat.

10.1.2 A lot of rod for mechanical testing shall be defined as the material from one heat in the same condition and specified thickness.

### 10.2 Sampling for Chemical Analysis:

10.2.1 A representative sample shall be obtained from each lot during pouring or subsequent processing.

10.2.2 Product (check) analysis shall be wholly the responsibility of the purchaser and shall conform to the product (check) analysis variations per Specification B880.

### 10.3 Sampling for Mechanical Testing:

10.3.1 A representative sample shall be taken from each lot of finished material.

## 11. Number of Tests and Retests

11.1 *Chemical Analysis*—One test per lot.

11.2 *Tension Tests*—One test per lot.

11.3 *Retests*—If the specimen used in the mechanical test of any lot fails to meet the specified requirements, two additional specimens shall be taken from different sample pieces and tested. The results of the tests on both of these specimens shall meet the specified requirements.

## 12. Specimen Preparation

12.1 Tension test specimens shall be taken from material after final heat treatment and tested in the direction of fabrication.

12.2 Tension test specimens shall be any of the standard or subsized specimens shown in Test Methods E8.

12.3 In the event of disagreement, the referee specimen shall be the largest possible round specimen shown in Test Methods E8.

## 13. Test Methods and Chemical Analysis

13.1 The chemical composition and mechanical properties of the material as enumerated in this specification shall be

determined, in case of disagreement, in accordance with the following ASTM methods:

13.1.1 *Chemical Analysis*—Test Methods E1473. For elements not covered by Test Methods E1473, the referee method shall be as agreed upon between the manufacturer and purchaser. The composition of the remainder element shall be determined arithmetically by difference.

13.1.2 *Tension Test*—Test Methods E8.

13.1.3 *Method of Sampling*—Practice E55.

13.1.4 *Determining Significant Places*—Practice E29.

13.2 For purposes of determining compliance with the limits in this specification, an observed value or a calculated value shall be rounded in accordance with the rounding method of Practice E29:

Requirements	Rounded Unit for Observed or Calculated Value
Chemical composition and tolerances	nearest unit in the last right-hand place of figures of the specified limit
Tensile strength and yield strength	nearest 1000 psi (7 MPa)
Elongation	nearest 1 %

## 14. Inspection

14.1 Inspection of the material shall be made as agreed upon by the manufacturer and the purchaser as part of the purchase contract.

## 15. Rejection and Rehearing

15.1 Material that fails to conform to the requirements of this specification may be rejected. Rejection should be reported to the producer or supplier promptly and in writing. In case of dissatisfaction with the results of the test, the producer or supplier may make claim for a rehearing.

## 16. Certification

16.1 A manufacturer's certification shall be furnished to the purchaser stating that material has been manufactured, tested, and inspected in accordance with this specification, and that the test results on representative samples meet specification requirements. A report of the test results shall be furnished.

## 17. Product Marking

17.1 Each piece of material ½ in. (12.7 mm) and over in diameter shall be marked with this specification number, name of the material, and size of the product.

17.2 Each bundle or shipping container shall be marked with the name of the material; this specification number; alloy; the size; gross, tare and net weight; consignor and consignee address; contract or other number; or such other information as may be defined in the contract or order.

## 18. Keywords

18.1 rod; N06007; N06975; N06985; N06030; N08031

**APPENDIX****(Nonmandatory Information)****X1. HEAT TREATMENT**

X1.1 Proper heat treatment during or subsequent to fabrication is necessary for optimum performance and the manufacturer shall be consulted for details.

ASMENORMDOC.COM : Click to view the full PDF of ASME BPVC.II.B (ASME BPVC Section II part B) 2025

ASMENORMDOC.COM : Click to view the full PDF of ASME BPVC.II.B (ASME BPVC Section II part B) 2025

INTENTIONALLY LEFT BLANK

# SPECIFICATION FOR NICKEL-CHROMIUM-IRON- MOLYBDENUM-COPPER ALLOY PLATE, SHEET, AND STRIP



**SB-582**

(Identical with ASTM Specification B582-07(2013) except that certification and test reports have been made mandatory by reference to SB-906.)

# Standard Specification for Nickel-Chromium-Iron-Molybdenum-Copper Alloy Plate, Sheet, and Strip

## 1. Scope

1.1 The specification covers plate, sheet, and strip of nickel-chromium-iron-molybdenum-copper alloys (UNS N06007, N06975, N06985, and N06030) as shown in Table 1, for use in general corrosive service.

1.2 The following products are covered under this specification:

1.2.1 *Sheet and Strip*—Hot or cold rolled, solution annealed, and descaled unless solution anneal is performed in an atmosphere yielding a bright finish.

1.2.2 *Plate*—Hot or cold rolled, solution annealed, and descaled.

1.3 The values stated in inch-pound units are to be regarded as the standard. The values given in parentheses are for information only.

1.4 *This standard does not purport to address all of the safety concerns, if any, associated with its use. It is the responsibility of the user of this standard to become familiar with all hazards including those identified in the appropriate Material Safety Data Sheet (MSDS) for this product/material as provided by the manufacturer, to establish appropriate safety and health practices, and determine the applicability of regulatory limitations prior to use.*

## 2. Referenced Documents

### 2.1 ASTM Standards:

B906 Specification for General Requirements for Flat-Rolled Nickel and Nickel Alloys Plate, Sheet, and Strip

## 3. Terminology

### 3.1 Definitions of Terms Specific to This Standard:

3.1.1 *cold-rolled plate, n*—material  $\frac{3}{16}$  to  $\frac{3}{8}$  in. (4.76 to 9.52 mm), inclusive, in thickness.

3.1.2 *hot-rolled plate, n*—material  $\frac{3}{16}$  in. (4.76 mm) and over in thickness.

3.1.3 *plate, n*—material  $\frac{3}{16}$  in. (4.76 mm) and over in thickness.

3.1.4 *sheet and strip, n*—material under  $\frac{3}{16}$  in. (4.76 mm) in thickness.

## 4. General Requirements

4.1 Materials furnished to this specification shall conform to the applicable requirements of Specification B906 unless otherwise provided herein.

## 5. Ordering Information

5.1 It is the responsibility of the purchaser to specify all requirements that are necessary for material ordered under this specification. Examples of such requirements include, but are not limited to, the following:

5.1.1 *Alloy*—Table 1,

5.1.2 *Dimensions*—Thickness (in decimals of an inch), width, and length (inch or fractions of an inch),

5.1.3 *Optional Requirement, Plate*—How the plate is to be cut (see 8.1 and Specification B906, Table A2.3),

5.1.4 DELETED

5.1.5 *Purchaser Inspection*—State which tests or inspections are to be witnessed (Specification B906), and

5.1.6 *Samples for Product (Check) Analysis*—State whether samples should be furnished (Section 6).

## 6. Chemical Composition

6.1 *Heat Analysis*—The material shall conform to the composition limits specified in Table 1.

6.2 *Product (Check) Analysis*—If a product (check) analysis is made by the purchaser, the material shall conform to the requirements specified in Table 1 subject to the permissible tolerances in Specification B906.

TABLE 1 Chemical Requirements

Element	Composition Limits, %			
	Alloy N06007	Alloy N06975	Alloy N06985	Alloy N06030
Nickel	remainder <sup>A</sup>	47.0 to 52.0	remainder <sup>A</sup>	remainder <sup>A</sup>
Chromium	21.0 to 23.5	23.0 to 26.0	21.0 to 23.5	28.0 to 31.5
Iron	18.0 to 21.0	remainder <sup>A</sup>	18.0 to 21.0	13.0 to 17.0
Molybdenum	5.5 to 7.5	5.0 to 7.0	6.0 to 8.0	4.0 to 6.0
Copper	1.5 to 2.5	0.70 to 1.20	1.5 to 2.5	1.0 to 2.4
Manganese	1.0 to 2.0	1.0 max	1.0 max	1.5 max
Cobalt, max	2.5	...	5.0	5.0
Carbon, max	0.05	0.03	0.015	0.03
Tungsten	1.0 max	...	1.5 max	1.5 to 4.0
Silicon, max	1.0	1.0	1.0	0.8
Phosphorus, max	0.04	0.03	0.04	0.04
Sulfur, max	0.03	0.03	0.03	0.02
Columbium + tantalum	1.75 to 2.50	...	0.50 max	0.30 to 1.50
Titanium	...	0.70–1.50	...	...

<sup>A</sup> The composition of the remainder element shall be determined arithmetically by difference.

7. Mechanical Properties and Other Requirements

7.1 *Tensile Properties*—The material shall conform to the mechanical property requirements prescribed in Table 2.

7.2 *Hardness*—The hardness values given in Table 2 are informative only.

8. Edges

8.1 Plates shall have sheared or cut machined, abrasive cut, powder cut, or inert arc cut edges, as specified.

8.2 Sheet and strip shall have sheared or slit edges.

9. Permissible Variations in Dimensions

9.1 *Weight*—For calculation of mass or weight, the following densities shall be used:

Alloy	lb/in. <sup>3</sup>	Density g/cm <sup>3</sup>
N06007	0.300	8.31
N06975	0.295	8.17
N06985	0.300	8.31
N06030	0.297	8.22

9.2 *Thicknesses:*

9.2.1 *Plate*—The permissible variations in thickness of plate shall be as prescribed in Specification B906, Table A2.1.

9.2.2 *Sheet and Strip*—The permissible variations in thickness of sheet and strip shall be as prescribed in Specification B906, Table A2.2. The thickness shall be measured with the micrometer spindle 3/8 in. (9.52 mm) or more from any edge for material 1 in. (25.4 mm) or over in width and at any place on material under 1 in. (25.4 mm) in width.

9.3 *Width:*

TABLE 2 Mechanical Property Requirements

Alloy	Thickness, in. (mm)	Tensile Strength min, psi (MPa)	Yield Strength (0.2 % Offset), min, psi (MPa)	Elongation in 2 in. or 50.8 mm or 4D <sup>A</sup> min, %	Rockwell Hardness, <sup>B</sup> max
Annealed Plate					
N06007	3/16 to 3/4 (4.76 to 19.05), incl	90 000 (621)	35 000 (241)	35	100 HRB
	Over 3/4 to 2 1/2 (19.05 to 63.5), incl	85 000 (586)	30 000 (207)	30	100 HRB
N06975	3/16 to 2 1/2 (4.76 to 63.5), incl	85 000 (586)	32 000 (221)	40	100 HRB
N06985	3/16 to 3/4 (4.76 to 19.05), incl	90 000 (621)	35 000 (241)	45	100 HRB
	Over 3/4 to 2 1/2 (19.05 to 63.5), incl	85 000 (586)	30 000 (207)	35	100 HRB
N06030	...	85 000 (586)	35 000 (241)	30	...
Annealed Sheet					
N06985	Over 0.020 (0.51)	90 000 (621)	35 000 (241)	45	100 HRB
Annealed Sheet and Strip					
N06007	Over 0.020 (0.51)	90 000 (621)	35 000 (241)	40	100 HRB
N06975	Over 0.020 (0.51)	85 000 (586)	32 000 (221)	40	100 HRB
N06030	Over 0.020 (0.51)	85 000 (586)	35 000 (241)	30	...

<sup>A</sup> D refers to the diameter of the tension specimen.

<sup>B</sup> Hardness values are shown for information purposes only and are not to be used as a basis for rejection or acceptance. For approximate hardness conversions, see Specification B906.

9.3.1 *Plate*—The permissible variations in width of rectangular plates shall be as prescribed in Specification B906, Table A2.3.

9.3.2 *Sheet and Strip*—The permissible variations in width for sheet and strip shall be as prescribed in Specification B906, Table A2.4.

9.4 *Length:*

9.4.1 *Plate*—Permissible variations in the length of rectangular plate shall be as prescribed in Specification B906, Table A2.3.

9.4.2 *Sheet and Strip*—Sheet and strip may be ordered to cut lengths, in which case a variation of  $\frac{1}{8}$  in. (3.18 mm) over the specified length shall be permitted, with a 0 minus tolerance.

9.5 *Straightness*—The edgewise curvature (depth of cord) of sheet, strip, and plate shall not exceed 0.05 in./ft (4.2 mm/m).

9.6 *Squareness (Sheet)*—For sheets of all thickness and widths of 6 in. (152.4 mm) or more, the angle between adjacent sides shall be  $90 \pm 0.15^\circ$  ( $\frac{1}{16}$  in. in 24 in. or 2.6 mm/m).

9.7 *Flatness*—Plate, sheet, and strip shall be commercially flat.

## 10. Product Marking and Package Marking

10.1 Each plate, sheet, or strip shall be marked on one face with the specification number, heat number, manufacturer's identification, and size. The markings shall have no deleterious effect on the material or its performance and shall be sufficiently stable to withstand normal handling.

10.2 Each bundle or shipping container shall be marked with the name of the material; this specification number; alloy; the size; gross, tare, and net weight; consignor and consignee address; contract or order number; and such other information as may be defined in the contract or order.

## 11. Keywords

11.1 plate; sheet; strip; N06007; N60975; N06985; N06030

## APPENDIX

(Nonmandatory Information)

### X1. HEAT TREATMENT

X1.1 Proper heat treatment during or subsequent to fabrication is necessary for optimum performance, and the manufacturer shall be consulted for details.

## SPECIFICATION FOR COPPER ALLOY SAND CASTINGS FOR GENERAL APPLICATIONS

**SB-584**

(25)

(Identical with ASTM Specification B584-22 except that certification and test reports have been made mandatory.)

*ASME SB-584 replaces paras. 5.1.5, 5.2.4, 5.2.5, 10.1, 10.3, and 11.2 of ASTM B584 with the following:*

5.1.5 DELETED

5.2.4 DELETED

5.2.5 DELETED

10.1 Castings shall comply with the following:

10.3 Alloys in this specification are generally weldable. Preparation for repair welding shall include inspection to ensure complete removal of the defect. Repairs shall be made utilizing welding procedures qualified in accordance with Section IX of the ASME code and repair welding shall be done by welders or welding operators meeting the qualification requirements of ASME Section IX. The following records shall be maintained:

11.2 For small remelts the lot size shall not exceed 1000 lb (455 kg) of castings and shall consist of all of the metal from a single master heat poured from an individual melting unit or group of melting units operating during the course of one-half shift, not to exceed 5 h.



Designation: B584 – 22

## Standard Specification for Copper Alloy Sand Castings for General Applications<sup>1</sup>

This standard is issued under the fixed designation B584; the number immediately following the designation indicates the year of original adoption or, in the case of revision, the year of last revision. A number in parentheses indicates the year of last reappraisal. A superscript epsilon ( $\epsilon$ ) indicates an editorial change since the last revision or reappraisal.

*This standard has been approved for use by agencies of the U.S. Department of Defense.*

### 1. Scope\*

1.1 This specification covers requirements for copper alloy sand castings for general applications. Nominal compositions of the alloys defined by this specification are shown in Table 1.<sup>2</sup> This is a composite specification replacing former documents as shown in Table 1.

NOTE 1—Other copper alloy castings are included in the following ASTM Specifications: B22/B22M, B61, B62, B66, B67, B148, B176, B271/B271M, B369/B369M, B427, B505/B505M, B763/B763M, B770, and B806.

1.2 Component part castings produced to this specification may be manufactured in advance and supplied from stock. In such cases the manufacturer shall maintain a general quality certification of all castings without specific record or date of casting for a specific casting.

1.3 The values stated in inch-pound units are to be regarded as standard. The values given in parentheses are mathematical conversions to SI units that are provided for information only and are not considered standard.

1.4 *This international standard was developed in accordance with internationally recognized principles on standardization established in the Decision on Principles for the Development of International Standards, Guides and Recommendations issued by the World Trade Organization Technical Barriers to Trade (TBT) Committee.*

### 2. Referenced Documents

#### 2.1 ASTM Standards:<sup>3</sup>

<sup>1</sup> This specification is under the jurisdiction of ASTM Committee B05 on Copper and Copper Alloys and is the direct responsibility of Subcommittee B05.05 on Castings and Ingots for Remelting.

Current edition approved Oct. 1, 2022. Published October 2022. Originally approved in 1973. Last previous edition approved in 2022 as B584 – 14 (2022). DOI: 10.1520/B0584-22.

<sup>2</sup> The UNS system for copper and copper alloys (see Practice E527) is a simple expansion of the former standard designation system accomplished by the addition of a prefix “C” and a suffix “00.” The suffix can be used to accommodate composition variations of the base alloy.

<sup>3</sup> For referenced ASTM standards, visit the ASTM website, [www.astm.org](http://www.astm.org), or contact ASTM Customer Service at [service@astm.org](mailto:service@astm.org). For *Annual Book of ASTM Standards* volume information, refer to the standard’s Document Summary page on the ASTM website.

- B22/B22M Specification for Bronze Castings for Bridges and Turntables
- B61 Specification for Steam or Valve Bronze Castings
- B62 Specification for Composition Bronze or Ounce Metal Castings
- B66 Specification for Bronze Castings for Steam Locomotive Wearing Parts
- B67 Specification for Car and Tender Journal Bearings, Lined
- B148 Specification for Aluminum-Bronze Sand Castings
- B176 Specification for Copper-Alloy Die Castings
- B208 Practice for Preparing Tension Test Specimens for Copper Alloy Sand, Permanent Mold, Centrifugal, and Continuous Castings
- B271/B271M Specification for Copper-Base Alloy Centrifugal Castings
- B369/B369M Specification for Copper-Nickel Alloy Castings
- B427 Specification for Gear Bronze Alloy Castings
- B505/B505M Specification for Copper Alloy Continuous Castings
- B763/B763M Specification for Copper Alloy Sand Castings for Valve Applications
- B770 Specification for Copper-Beryllium Alloy Sand Castings for General Applications
- B806 Specification for Copper Alloy Permanent Mold Castings for General Applications
- B824 Specification for General Requirements for Copper Alloy Castings
- B846 Terminology for Copper and Copper Alloys
- E255 Practice for Sampling Copper and Copper Alloys for the Determination of Chemical Composition
- E527 Practice for Numbering Metals and Alloys in the Unified Numbering System (UNS)

#### 2.2 ASME Code:<sup>4</sup> ASME

<sup>4</sup> Available from American Society of Mechanical Engineers (ASME), ASME International Headquarters, Two Park Ave., New York, NY 10016-5990, <http://www.asme.org>.

TABLE 1 Nominal Compositions

Classification	Copper Alloy UNS No.	Previous Designation	Commercial Designation	Copper	Tin	Lead	Zinc	Nickel	Sulfur	Iron	Aluminum	Manganese	Antimony	Silicon	Niobium	Phosphorus	Bismuth
Leaded red brass	C83450	...	...	88	2½	2	6½	1	...	...	...	...	...	...	...	...	...
Low-lead sulfur tin bronze	C83470	...	...	93	4	...	2	0.5	0.5	...	...	...	...	...	...	...	...
Leaded red brass	C83600	B145-4A	85-5-5-5 or No. 1 composition	85	5	5	5	...	...	...	...	...	...	...	...	...	...
	C83800	B145-4B	commercial red brass, 83-4-6-7	83	4	6	7	...	...	...	...	...	...	...	...	...	...
Low-lead semi-red brass	C84020	...	...	85.5	3	...	9	1.2	0.38	...	...	...	...	...	...	...	...
	C84030	...	...	85.5	3	...	9	1.2	0.38	...	...	...	0.8	...	...	...	...
Leaded semi-red brass	C84400	B145-5A	valve composition, 81-3-7-9	81	3	7	9	...	...	...	...	...	...	...	...	...	...
	C84800	B145-5B	semi-red brass, 76-2½-6½-15	76	2½	6½	15	...	...	...	...	...	...	...	...	...	...
Leaded yellow brass	C85200	B146-6A	high-copper yellow brass	72	1	3	24	...	...	...	...	...	...	...	...	...	...
	C85400	B146-6B	commercial No. 1 yellow brass	67	1	3	29	...	...	...	...	...	...	...	...	...	...
Yellow brass	C85470 <sup>A</sup>	...	...	62.5	2.5	...	34.3	...	...	...	0.5	...	...	...	...	...	...
Leaded yellow brass	C85700	B146-6C	leaded naval brass	61	1	1	37	...	...	...	...	...	...	...	...	...	...
High-strength yellow brass	C86200	B147-8B	high-strength manganese bronze	63	...	...	27	...	...	3	4	3	...	...	...	...	...
	C86300	B147-8C	high-strength manganese bronze	61	...	...	27	...	...	3	6	3	...	...	...	...	...
	C86400	B147-7A	leaded manganese bronze	58	1	1	38	...	...	1	½	½	...	...	...	...	...
	C86400	B 132-A	...	...	...	...	...	...	...	...	...	...	...	...	...	...	...
	C86500	B147-8A	No. 1 manganese bronze	58	...	...	39	...	...	1	1	1	...	...	...	...	...
	C86700	B 132-B	leaded manganese bronze	58	1	1	34	...	...	2	2	2	...	...	...	...	...
Silicon bronze + silicon brass	C87300	B198-12A	silicon bronze	95	...	...	...	...	...	...	...	1	...	4	...	...	...
	C87400	B198-13A	silicon brass	82	...	½	14	...	...	...	...	...	...	3½	...	...	...
	C87500	B198-13B	silicon brass	82	...	...	14	...	...	...	...	...	...	4	...	...	...
	C87600	B198-13C	silicon bronze	91	...	...	5	...	...	...	...	...	...	4	...	...	...
	C87610	B198-12A	silicon bronze	92	...	...	4	...	...	...	...	...	...	4	...	...	...
	C87710	...	silicon bronze	86	...	...	10	...	...	...	...	...	...	4	...	...	...
	C87845 <sup>B</sup>	...	silicon bronze	76	...	...	21.26	...	...	...	...	...	...	2.7	...	...	...
	C87850 <sup>C</sup>	...	silicon brass	76	...	...	20.9	...	...	...	...	...	...	3	...	...	...
Bismuth selenium brass	C89510 <sup>D</sup>	...	sebiloy I	87	5	...	5	...	...	...	...	...	...	...	...	...	1.0
	C89520 <sup>E</sup>	...	sebiloy II	86	5½	...	5	...	...	...	...	...	...	...	...	...	1.9
	C89530 <sup>F</sup>	...	...	86.5	4.7	...	8.0	...	...	...	...	...	...	...	...	...	1.5
	C89535	...	...	86.5	3.0	...	7.0	0.65	...	...	...	...	...	...	...	...	1.4
Bismuth brass	C89537	...	...	85.0	4.5	...	9.0	...	...	...	...	...	...	0.9	...	...	1.7
	C89545 <sup>G</sup>	...	...	69.0	...	...	29.0	0.5	...	...	1.0	...	...	...	0.13	...	0.55
	C89570 <sup>H</sup>	...	...	60.5	0.8	...	36.5	0.32	...	...	0.5	...	...	...	...	...	1.0
	C89720 <sup>I</sup>	...	...	67.5	1	...	29.8	...	...	...	0.5	...	...	0.5	...	...	0.7
Bismuth red brass	C89833	...	bismuth brass	89	5	...	3	...	...	...	...	...	...	...	...	...	2.2
Bismuth bronze	C89836	...	lead-free bronze	89.5	5.5	...	3.0	...	...	...	...	...	...	...	...	...	2
Bismuth brass	C89838	...	...	81.5	2.75	...	15.0	...	...	...	...	...	...	...	...	...	0.55
Bismuth semi-red brass	C89844	...	bismuth brass	84½	...	...	...	...	...	...	...	...	...	...	...	...	...
	C89845	...	...	85.0	4.0	...	7.5	2.0	...	...	...	...	...	...	...	...	1.5
Tin bronze + leaded tin bronze	C90300	B143-1B	modified "G" bronze, 88-8-0-4	88	8	...	4	...	...	...	...	...	...	...	...	...	...
Low-lead tin bronze	C90420	...	...	87.5	8	...	3	...	0.38	...	...	...	...	...	...	...	...
Tin bronze + leaded tin bronze	C90500	B143-1A	"G" bronze, 88-10-0-2	88	10	...	2	...	...	...	...	...	...	...	...	...	...
	C92200	B143-2A	steam or valve bronze-Navy "M"	88	6	1½	4½	...	...	...	...	...	...	...	...	...	...
	C92210	...	...	88	5	2	4	1	...	...	...	...	...	...	...	...	...

TABLE 1 Continued

Classification	Copper Alloy UNS No.	Previous Designation	Commercial Designation	Copper	Tin	Lead	Zinc	Nickel	Sulfur	Iron	Aluminum	Manganese	Antimony	Silicon	Niobium	Phosphorus	Bismuth
High-lead tin bronze	C92300	B143-2B	87-5-1-4, Navy PC	87	8	1	4	...	...	...	...	...	...	...	...	...	...
	C92600	...	87-10-1-2	87	10	1	2	...	...	...	...	...	...	...	...	...	...
	C93200	B144-3B	83-7-7-3	83	7	7	3	...	...	...	...	...	...	...	...	...	...
	C93500	B144-3C	85-5-9-1	85	5	9	1	...	...	...	...	...	...	...	...	...	...
	C93700	B144-3A	80-10-10	80	10	10	...	...	...	...	...	...	...	...	...	...	...
	C93800	B144-3D	78-7-15	78	7	15	...	...	...	...	...	...	...	...	...	...	...
Nickel-tin bronze + leaded nickel-tin bronze	C94300	B144-3E	71-5-24	71	5	24	...	...	...	...	...	...	...	...	...	...	...
	C94700	B 292-A	nickel-tin bronze Grade "A"	88	5	...	2	5	...	...	...	...	...	...	...	...	...
	C94800	B 292-B	leaded nickel-tin bronze Grade "B"	87	5	1	2	5	...	...	...	...	...	...	...	...	...
	C94900	...	leaded nickel-tin bronze Grade "C"	80	5	5	5	5	...	...	...	...	...	...	...	...	...
Spinodal alloy Leaded nickel bronze	C96800	...	...	82	8	...	...	10	...	...	...	...	...	...	0.2	...	...
	C97300	B149-10A	12 % leaded nickel silver	57	2	9	20	12	...	...	...	...	...	...	...	...	...
	C97600	B149-11A	20 % leaded nickel silver	64	4	4	8	20	...	...	...	...	...	...	...	...	...
	C97800	B149-11B	25 % leaded nickel silver	66	5	2	2	25	...	...	...	...	...	...	...	...	...

<sup>A</sup> Phosphorus 0.13.  
<sup>B</sup> Phosphorus 0.04.  
<sup>C</sup> Phosphorus 0.12.  
<sup>D</sup> Selenium 0.5.  
<sup>E</sup> Selenium 0.9.  
<sup>F</sup> Selenium 0.20.  
<sup>G</sup> Phosphorus 0.05.  
<sup>H</sup> Phosphorus 0.1.  
<sup>I</sup> Antimony 0.07, Boron 0.001.

**3. Terminology**

3.1 Definitions of terms relating to copper alloys can be found in Terminology B846.

**4. General Requirements**

4.1 The following sections of Specification B824 form a part of this specification. In the event of a conflict between this specification and Specification B824, the requirements of this specification shall take precedence.

- 4.1.1 Terminology,
- 4.1.2 Other Requirements,
- 4.1.3 Dimensions, Mass, and Permissible Variations,
- 4.1.4 Workmanship, Finish, and Appearance,
- 4.1.5 Sampling,
- 4.1.6 Number of Tests and Retests,
- 4.1.7 Specimen Preparation,
- 4.1.8 Test Methods,
- 4.1.9 Significance of Numerical Limits,
- 4.1.10 Inspection,
- 4.1.11 Rejection and Rehearing,
- 4.1.12 Certification,
- 4.1.13 Test Report,
- 4.1.14 Product Marking,
- 4.1.15 Packaging and Package Marking, and
- 4.1.16 Supplementary Requirements.

**5. Ordering Information**

5.1 Orders for castings under this specification should include the following information:

- 5.1.1 Specification title, number, and year of issue;
- 5.1.2 Quantity of castings;
- 5.1.3 Copper alloy UNS Number (Table 1) and temper (as-cast, heat treated, and so forth);
- 5.1.4 Pattern or drawing number, and condition (as-cast, machined, etc.);
- 5.1.5 ASME Boiler and Pressure Vessel Code compliance (Section 10); and
- 5.1.6 When material is purchased for agencies of the U.S. government, the Supplementary Requirements of Specification B824 may be specified.
- 5.2 The following options are available and should be specified in the purchase order when required:
  - 5.2.1 Chemical analysis of residual elements (7.3),
  - 5.2.2 Pressure test or soundness requirements (Specification B824),
  - 5.2.3 Approval of weld repair or impregnation, or both (Section 9),
  - 5.2.4 Certification (Specification B824),
  - 5.2.5 Foundry test report (Specification B824), B824), and
  - 5.2.7 Product marking (Specification B824).

**6. Manufacture**

6.1 Copper alloy UNS Nos. C94700 and C96800 may be supplied in the heat treated condition to obtain the higher mechanical properties shown in Table 2. Suggested heat treatments for these alloys are given in Table 3. Actual practice may vary by manufacturer.

TABLE 2 Mechanical Requirements

Copper Alloy UNS No.	Tensile Strength, min		Yield Strength, <sup>A</sup> min		Elongation in 2 in. or 50 mm, min, %
	ksi <sup>B</sup>	MPa <sup>C</sup>	ksi <sup>B</sup>	MPa <sup>C</sup>	
C83450	30	207	14	97	25
C83470	28	195	14	97	15
C83600	30	207	14	97	20
C83800	30	207	13	90	20
C84020	38	262	16	110	22
C84030	34	234	16	110	17
C84400	29	200	13	90	18
C84800	28	193	12	83	16
C85200	35	241	12	83	25
C85400	30	207	11	76	20
C85470	50	345	21	150	15
C85700	40	276	14	97	15
C86200	90	621	45	310	18
C86300	110	758	60	414	12
C86400	60	414	20	138	15
C86500	65	448	25	172	20
C86700	80	552	32	221	15
C87300	45	310	18	124	20
C87400	50	345	21	145	18
C87500	60	414	24	165	16
C87600	60	414	30	207	16
C87610	45	310	18	124	20
C87710	47	324	24	165	10
C87845	52	359	18	124	29
C87850	59	407	22	152	16
C89510	26	184	17	120	8
C89520	25	176	17	120	6
C89530	28	195	13 <sup>D</sup>	90 <sup>D</sup>	15
C89535	32	220	16 <sup>D</sup>	110 <sup>D</sup>	15
C89537	14	100	13	90	5
C89545	31	215	10	70	20
C89570	50	350	26	180	10
C89720	30	210	16	110	15
C89833	30	207	14	97	16
C89836	33	229	14	97	20
C89838	28	195	10	70	15
C89844	28	193	13	90	15
C89845	28	195	15	100	15
C90300	40	276	18	124	20
C90420	41	283	22	152	17
C90500	40	276	18	124	20
C92200	34	234	16	110	22
C92210	32	225	15	103	20
C92300	36	248	16	110	18
C92600	40	276	18	124	20
C93200	30	207	14	97	15
C93500	28	193	12	83	15
C93700	30	207	12	83	15
C93800	26	179	14	97	12
C94300	24	165	...	...	10
C94700	45	310	20	138	25
C94700 (HT)	75	517	50	345	5
C94800	40	276	20	138	20
C94900	38	262	15	103	15
C96800	125	862	100 <sup>D</sup>	689 <sup>D</sup>	3
C96800 (HT)	135	931	120 <sup>D</sup>	821 <sup>D</sup>	...
C97300	30	207	15	103	8
C97600	40	276	17	117	10
C97800	50	345	22	152	10

<sup>A</sup> Yield strength shall be determined as the stress producing an elongation under load of 0.5 %, that is, 0.01 in. (0.254 mm) in a gage length of 2 in. or 50 mm.

<sup>B</sup> ksi = 1000 psi.

<sup>C</sup> See Appendix X1.

<sup>D</sup> Yield strength 0.2 %, offset.

6.2 Separately cast test bar coupons representing castings made in copper alloy UNS Nos. C94700HT and C96800HT shall be heat treated with the castings.

TABLE 3 Suggested Heat Treatments

Copper Alloy UNS No.	Solution Treatment (not less than 1 h followed by water quench)	Annealing Treatment (not less than 2 h followed by air cool)
C96800	1500 °F (815 °C)	(Age to develop properties) 660 °F (350 °C) Precipitation hardening (5 h)
C94700	Solution treatment (not less than 2 h followed by water quench) 1425 °F–1475 °F (775 °C–800 °C)	580 °F–620 °F (305 °C–325 °C)

## 7. Chemical Composition

7.1 The castings shall conform to the compositional requirements for named elements as shown in Table 4 for the copper alloy UNS numbers specified in the purchase order.

7.2 These specification limits do not preclude the presence of other elements. Limits may be established and analysis required for unnamed elements agreed upon between manufacturer or supplier and purchaser. Copper or zinc, when zinc is 20 % or greater, may be given as remainder and may be taken as the difference between the sum of all elements analyzed and 100 %. When all named elements in Table 4 are analyzed, their sum shall be as specified in Table 5.

7.3 It is recognized that residual elements may be present in cast copper alloys. Analysis shall be made for residual elements only when specified in the purchase order.

## 8. Mechanical Properties

8.1 Mechanical properties shall be determined from separately cast test bar castings, and shall meet the requirements shown in Table 2.

## 9. Casting Repair

9.1 The castings shall not be weld repaired without approval of the purchaser (5.2.3).

9.2 The castings shall not be impregnated without approval of the purchaser (5.2.3).

## 10. ASME Requirements

10.1 When specified in the purchase order to meet ASME Boiler and Pressure Vessel Code requirements, castings in copper alloy UNS Nos. C92200, C93700, and C97600 shall comply with the following:

10.1.1 Certification requirements of Specification B824.

10.1.2 Foundry test report requirements of Specification B824.

10.1.3 Castings shall be marked with the manufacturer's

factor. In addition, heat numbers or serial numbers that are traceable to heat numbers shall be marked on all pressure-containing castings individually weighing 50 lb (22.7 kg) or more. Pressure-containing castings weighing less than 50 lb (22.7 kg) shall be marked with either the heat number or a serial number that will identify the casting as to the month in which it was poured. Marking shall be in such a position as to not impair the usefulness of the casting.

TABLE 4 Chemical Requirements

Composition, % Max Except as Indicated

Copper Alloy UNS No.	Copper	Tin	Lead	Zinc	Iron	Nickel Incl. Cobalt	Aluminum	Manganese	Silicon	Bismuth	Selenium	Antimony	Sulfur	Phosphorus	Boron	Zirconium	Carbon	Titanium
C83450	87.0–89.0 <sup>A</sup>	2.0–3.5	1.5–3.0	5.5–7.5	0.30	0.75–2.0 <sup>A</sup>	0.005	...	0.005	...	...	0.25	0.08	0.05	...	...	...	...
C83470	90.0–96.0 <sup>A</sup>	3.0–5.0	0.09	1.0–3.0	0.50	1.0	0.01	...	0.01	...	...	0.20	0.20–0.6	0.10 <sup>B</sup>	...	...	...	...
C83600	84.0–86.0 <sup>A</sup>	4.0–6.0	4.0–6.0	4.0–6.0	0.30	1.0 <sup>A</sup>	0.005	...	0.005	...	...	0.25	0.08	0.05	...	...	...	...
C83800	82.0–83.8 <sup>A</sup>	3.3–4.2	5.0–7.0	5.0–8.0	0.30	1.0 <sup>A</sup>	0.005	...	0.005	...	...	0.25	0.08	0.03	...	...	...	...
C84020	82.0–89.0	2.0–4.0	0.09	5.0–14.0	0.40	0.50–2.0	0.005	0.20	0.005	...	...	0.02	0.10–0.65	0.05	0.10	0.10	0.10	0.10
C84030	82.0–89.0	2.0–4.0	0.09	5.0–14.0	0.40	0.50–2.0	0.005	0.20	0.005	...	...	0.10–1.5	0.10–0.65	0.05	0.10	0.10	0.10	0.10
C84400	78.0–82.0 <sup>A</sup>	2.3–3.5	6.0–8.0	7.0–10.0	0.40	1.0 <sup>A</sup>	0.005	...	0.005	...	...	0.25	0.08	0.02	...	...	...	...
C84800	75.0–77.0 <sup>A</sup>	2.0–3.0	5.5–7.0	13.0–17.0	0.40	1.0 <sup>A</sup>	0.005	...	0.005	...	...	0.25	0.08	0.02	...	...	...	...
C85200	70.0–74.0 <sup>A</sup>	0.7–2.0	1.5–3.8	20.0–27.0	0.6	1.0 <sup>A</sup>	0.005	...	0.05	...	...	0.20	0.05	0.02	...	...	...	...
C85400	65.0–70.0 <sup>A</sup>	0.50–1.5	1.5–3.8	24.0–32.0	0.7	1.0 <sup>A</sup>	0.35	...	0.05	...	...	...	...	...	...	...	...	...
C85470	60.0–65.0	1.0–4.0	0.09	Remainder	0.20	...	0.10–1.0	...	...	...	...	...	...	0.02–0.25	...	...	...	...
C85700	58.0–64.0 <sup>A</sup>	0.50–1.5	0.8–1.5	32.0–40.0	0.7	1.0 <sup>A</sup>	0.80	...	0.05	...	...	...	...	...	...	...	...	...
C86200	60.0–66.0 <sup>A</sup>	0.20	0.20	22.0–28.0	2.0–4.0	1.0 <sup>A</sup>	3.0–4.9	2.5–5.0	...	...	...	...	...	...	...	...	...	...
C86300	60.0–66.0 <sup>A</sup>	0.20	0.20	22.0–28.0	2.0–4.0	1.0 <sup>A</sup>	5.0–7.5	2.5–5.0	...	...	...	...	...	...	...	...	...	...
C86400	56.0–62.0 <sup>A</sup>	0.50–1.5	0.50–1.5	34.0–42.0	0.40–2.0	1.0 <sup>A</sup>	0.50–1.5	0.10–1.0	...	...	...	...	...	...	...	...	...	...
C86500	55.0–60.0 <sup>A</sup>	1.0	0.40	36.0–42.0	0.40–2.0	1.0 <sup>A</sup>	0.50–1.5	0.10–1.5	...	...	...	...	...	...	...	...	...	...
C86700	55.0–60.0 <sup>A</sup>	1.5	0.50–1.5	30.0–38.0	1.0–3.0	1.0 <sup>A</sup>	1.0–3.0	1.0–3.5	...	...	...	...	...	...	...	...	...	...
C87300	94.0 min	...	0.09	0.25	0.20	...	...	0.8–1.5	3.5–4.5	...	...	...	...	...	...	...	...	...
C87400	79.0 min	...	1.0	12.0–16.0	...	...	0.80	...	2.5–4.0	...	...	...	...	...	...	...	...	...
C87500	79.0 min	...	0.09	12.0–16.0	...	...	0.50	...	3.0–5.0	...	...	...	...	...	...	...	...	...
C87600	88.0 min	...	0.09	4.0–7.0	0.20	...	...	0.25	3.5–5.5	...	...	...	...	...	...	...	...	...
C87610	90.0 min	...	0.09	3.0–5.0	0.20	...	...	0.25	3.0–5.0	...	...	...	...	...	...	...	...	...
C87710	84.0 min	2.0	0.09	9.0–11.0	0.50	0.25	...	0.80	3.0–5.0	...	...	0.10	...	0.15	...	...	...	...
C87845 <sup>C</sup>	75.0–78.0	0.10	0.02	Remainder	0.10	0.20	0.09	0.10	2.5–2.9	...	...	0.015	...	0.03–0.06	...	...	...	...
				der	0.10	0.20	...	0.10	2.7–3.4	...	...	0.10	...	0.05–0.20	...	...	...	...
				der														
C89537 <sup>D</sup>															0.0020	...	...	...
															0.0020	...	...	...
															0.01 %	...	...	...
C89845	82.5–87.5	3.0–4.0	0.09	6.0–9.0	0.30	1.5–2.5	0.005	...	0.005	2.0–4.0	...	0.25	0.08	0.05	...	...	...	...
C90300	86.0–89.0 <sup>A</sup>	7.5–9.0	0.30	3.0–5.0	0.20	1.0 <sup>A</sup>	0.005	...	0.01	1.0–2.0	...	0.25	...	0.05	...	...	...	...
C90420	86.0–89.0	7.5–8.5	0.09	1.0–5.0	0.40	1.0	0.005	0.20	0.005	...	...	0.20	0.05	0.05	...	...	...	...
C90500	86.0–89.0 <sup>A</sup>	9.0–11.0	0.30	1.0–3.0	0.20	1.0 <sup>A</sup>	0.005	...	0.005	...	...	0.02	0.10–0.65	0.05	0.10	0.10	0.10	0.10
C92200	86.0–90.0 <sup>A</sup>	5.5–6.5	1.0–2.0	3.0–5.0	0.25	1.0 <sup>A</sup>	0.005	...	0.005	...	...	0.20	0.05	0.05	...	...	...	...
C92210	86.0–89.0 <sup>A</sup>	4.5–5.5	1.7–2.5	3.0–4.5	0.25	0.7–1.0 <sup>A</sup>	0.005	...	0.005	...	...	0.25	0.05	0.05	...	...	...	...
C92300	85.0–89.0 <sup>A</sup>	7.5–9.0	0.30–1.0	2.5–5.0	0.25	1.0 <sup>A</sup>	0.005	...	0.005	...	...	0.20	0.05	0.03	...	...	...	...
C92600	86.0–88.5 <sup>A</sup>	9.3–10.5	0.8–1.5	1.3–2.5	0.20	0.7 <sup>A</sup>	0.005	...	0.005	...	...	0.25	0.05	0.05	...	...	...	...

ASME BPVC.II.B (ASME BPVC Section II part B) 2025

TABLE 4 Continued

Composition, % Max Except as Indicated																		
Copper Alloy UNS No.	Copper	Tin	Lead	Zinc	Iron	Nickel Incl. Cobalt	Aluminum	Manganese	Silicon	Bismuth	Selenium	Antimony	Sulfur	Phosphorus	Boron	Zirconium	Carbon	Titanium
C93200	81.0–85.0 <sup>A</sup>	6.3–7.5	6.0–8.0	2.0–4.0	0.20	1.0 <sup>A</sup>	0.005	...	0.005	...	...	0.35	0.08	0.15	...	...	...	...
C93500	83.0–86.0 <sup>A</sup>	4.3–6.0	8.0–10.0	2.0	0.20	1.0 <sup>A</sup>	0.005	...	0.005	...	...	0.30	0.08	0.05	...	...	...	...
C93700	78.0–82.0	9.0–11.0	8.0–11.0	0.8	0.15	0.50 <sup>A</sup>	0.005	...	0.005	...	...	0.50	0.08	0.10 <sup>B</sup>	...	...	...	...
C93800	75.0–79.0	6.3–7.5	13.0–16.0	0.8	0.15	1.0 <sup>A</sup>	0.005	...	0.005	...	...	0.80	0.08	0.05	...	...	...	...
C94300	67.0–72.0	4.5–6.0	23.0–27.0	0.8	0.15	1.0	0.005	...	0.005	...	...	0.80	0.08	0.05	...	...	...	...
C94700	85.0–90.0	4.5–6.0	0.09 <sup>E</sup>	1.0–2.5	0.25	4.5–6.0	0.005	0.20	0.005	...	...	0.15	0.05	0.05	...	...	...	...
C94800	84.0–89.0	4.5–6.0	0.30–1.0	1.0–2.5	0.25	4.5–6.0	0.005	0.20	0.005	...	...	0.15	0.05	0.05	...	...	...	...
C94900	79.0–81.0	4.0–6.0	4.0–6.0	4.0–6.0	0.30	4.0–6.0	0.005	0.10	0.005	...	...	0.25	0.08	0.05	...	...	...	...
C96800 <sup>F</sup>	remainder	7.5–8.5	0.005	1.0	0.50	9.5–10.5	0.10	0.05–0.30	0.05	0.001	...	0.02	0.0025	0.005	...	...	...	...
C97300	53.0–58.0	1.5–3.0	8.0–11.0	17.0–25.0	1.5	11.0–14.0	0.005	0.50	0.15	...	...	0.35	0.08	0.05	...	...	...	...
C97600	63.0–67.0	3.5–4.5	3.0–5.0	3.0–9.0	1.5	19.0–21.5	0.005	1.0	0.15	...	...	0.25	0.08	0.05	...	...	...	...

A

B

C

D Magnesium 0.01–0.10.

E

F

TABLE 5 Sum of All Named Elements Analyzed

Copper Alloy UNS Number	Copper Plus Sum of Named Elements, % Minimum
C83450	99.3
C83470	99.5
C83600	99.3
C83800	99.3
C84020	99.3
C84030	99.3
C84400	99.3
C84800	99.3
C85200	99.1
C85400	98.9
C85470	99.5
C85700	98.7
C86200	99.0
C86300	99.0
C86400	99.0
C86500	99.0
C86700	99.0
C87300	99.5
C87400	99.2
C87500	99.5
C87600	99.5
C87610	99.5
C87710	99.2
C87845	99.5
C87850	99.5
C89510	99.3
C89520	99.3
C89530	99.5
C89535	99.5
C89537	99.5
C89545	99.5
C89570	99.5
C89720	99.5
C89833	99.3
C89836	99.5
C89838	99.5
C89844	99.3
C89845	99.5
C90300	99.4
C90420	99.3
C90500	99.7
C92200	99.3
C92210	99.3
C92300	99.3
C92600	99.3
C93200	99.2
C93500	99.4
C93700	99.0
C93800	98.9
C94300	99.0
C94700	99.3
C94800	99.3
C94900	99.2
C96800	99.5
C97300	99.0
C97600	99.7
C97800	99.6

10.2 The castings shall not be repaired, plugged, welded, or “burned in” unless permission from the purchaser has been previously secured. This will be given only when the defects are such that after the approved repair the usefulness and strength of the castings has not been impaired.

10.3 Alloys in this specification are generally weldable. Preparation for repair welding shall include inspection to ensure complete removal of the defect. Repairs shall be made utilizing welding procedures qualified in accordance with Section IX if the ASME code and repair welding shall be done

by welders or welding operators meeting the qualification

be maintained:

- 10.3.1 A sketch or drawing showing the dimensions, depth, and location of excavations,
- 10.3.2 Postweld heat treatment, when applicable,
- 10.3.3 Weld repair inspection results,
- 10.3.4 Casting identification number,
- 10.3.5 Weld procedure identification number,
- 10.3.6 Welder identification, and

10.3.7 Name of inspector.

## 11. Sampling

11.1 Test bar castings for copper alloy UNS Nos. C86200, C86300, C86400, C86500, and C86700 shall be cast to the form and dimensions shown in Figs. 1 or 2 of Practice B208. Test bar castings for all other alloys listed in this specification shall be cast to the form and dimensions shown in Figs. 2, 3, or 4 of Practice B208.

11.2 When castings are specified to meet the requirements of the ASME Boiler and Pressure Vessel Code, for small remelts the lot size shall not exceed 1000 lb (455 kg) of

castings and shall consist of all of the metal from a single master heat poured from an individual melting unit or group of melting units operating during the course of one-half shift, not to exceed 5 h.

## 12. Test Methods

12.1 Analytical chemical methods are given in Specification B824.

## 13. Keywords

13.1 copper alloy castings; copper-base alloy castings; sand castings

## APPENDIX

### (Nonmandatory Information)

#### X1. METRIC EQUIVALENTS

X1.1 The SI unit for strength properties now shown is in accordance with the International System of Units (SI). The derived SI unit for force is the newton (N), which is defined as that force that when applied to a body having a mass of one kilogram gives it an acceleration of one metre per second squared ( $N = \text{kg}\cdot\text{m}/\text{s}^2$ ). The derived SI unit for pressure or

stress is the newton per square metre ( $\text{N}/\text{m}^2$ ), which has been named the pascal (Pa) by the General Conference on Weights and Measures. Since  $1 \text{ ksi} = 6\,894\,757 \text{ Pa}$ , the metric equivalents are expressed as megapascal (MPa), which is the same as  $\text{MN}/\text{m}^2$  and  $\text{N}/\text{mm}^2$ .

## SUMMARY OF CHANGES

Committee B05 has identified the location of selected changes to this standard since the last issue (B584 – 14 (2022)) that may impact the use of this standard. (Approved Oct. 1, 2022.)

(1) Added UNS Alloy Nos. C89545, C89838, and C89845 to Table 1, Table 2, Table 4, and Table 5.

*ASTM International takes no position respecting the validity of any patent rights asserted in connection with any item mentioned in this standard. Users of this standard are expressly advised that determination of the validity of any such patent rights, and the risk of infringement of such rights, are entirely their own responsibility.*

*This standard is subject to revision at any time by the responsible technical committee and must be reviewed every five years and if not revised, either reapproved or withdrawn. Your comments are invited either for revision of this standard or for additional standards and should be addressed to ASTM International Headquarters. Your comments will receive careful consideration at a meeting of the responsible technical committee, which you may attend. If you feel that your comments have not received a fair hearing you should make your views known to the ASTM Committee on Standards, at the address shown below.*

*This standard is copyrighted by ASTM International, 100 Barr Harbor Drive, PO Box C700, West Conshohocken, PA 19428-2959, United States. Individual reprints (single or multiple copies) of this standard may be obtained by contacting ASTM at the above address or at 610-832-9585 (phone), 610-832-9555 (fax), or service@astm.org (e-mail); or through the ASTM website (www.astm.org). Permission rights to photocopy the standard may also be secured from the Copyright Clearance Center, 222*

ASMENORMDOC.COM : Click to view the full PDF of ASME BPVC.II.B (ASME BPVC Section II part B) 2025

INTENTIONALLY LEFT BLANK

# SPECIFICATION FOR NICKEL-IRON-CHROMIUM- MOLYBDENUM-COLUMBIUM STABILIZED ALLOY (UNS N08700) PLATE, SHEET, AND STRIP



**SB-599**



(Identical with ASTM Specification B599-92<sup>e1</sup>(2014).)

ASMENORMDOC.COM : Click to view the full PDF of ASME BPVC.II.B (ASME BPVC Section II part B) 2025

# SPECIFICATION FOR NICKEL-IRON-CHROMIUM-MOLYBDENUM-COLUMBIUM STABILIZED ALLOY (UNS N08700) PLATE, SHEET, AND STRIP



SB-599

[Identical with ASTM Specification B 599-92<sup>e1</sup>(2014).]

## 1. Scope

**1.1** This specification covers nickel-iron-chromium-molybdenum-columbium stabilized alloy (UNS N08700) plate, sheet, and strip in the solution-annealed condition.

**1.2** The values stated in inch-pound units are to be regarded as the standard.

## 2. Referenced Documents

### 2.1 ASTM Standards:

- A 262 Practices for Detecting Susceptibility to Intergranular Attack in Austenitic Stainless Steels
- E 8 Test Methods of Tension Testing of Metallic Materials
- E 10 Test Method for Brinell Hardness of Metallic Materials
- E 18 Test Methods for Rockwell Hardness and Rockwell Superficial Hardness of Metallic Materials
- E 29 Practice for Using Significant Digits in Test Data to Determine Conformance with Specifications
- E 55 Practice for Sampling Wrought Nonferrous Metals and Alloys for Determination of Chemical Composition
- E 140 Hardness Conversion Tables for Metals (Relationship Between Brinell Hardness, Vickers Hardness, Rockwell Hardness, Rockwell Superficial Hardness, and Knoop Hardness)
- E 350 Test Method for Chemical Analysis of Carbon Steel, Low-Alloy Steel, Silicon Electrical Steel, Ingot Iron, and Wrought Iron
- E 353 Test Methods for Chemical Analysis of Stainless, Heat-Resisting, Maraging, and Other Similar Chromium-Nickel-Iron Alloys

## 3. Terminology

### 3.1 Descriptions of Terms Specific to This Standard:

**3.1.1** The terms plate, sheet, and strip as used in this specification are described as follows:

**3.1.1.1 plate** — material 0.1875 in. (4.76 mm) and over in thickness and over 10 in. (254 mm) in width.

**3.1.1.2 sheet** — material under 0.1875 in. (4.76 mm) in thickness and over 24 in. (610 mm) in width.

**3.1.1.3 strip** — material under 0.1875 in. (4.76 mm) in thickness and under 24 in. (610 mm) in width.

## 4. Ordering Information

**4.1** Orders for material under this specification should include the following information:

- 4.1.1** Quantity (weight or number of pieces).
- 4.1.2** Name of material or UNS N08700.
- 4.1.3** Form (plate, sheet, or strip).
- 4.1.4** Dimensions.
- 4.1.5** Type of edge required (for strip only, see 9.4).
- 4.1.6 Finish** (Section 10) — For sheet ordered with No.4 finish, specify whether one or both sides are to be polished.
- 4.1.7** ASTM designation and year of issue.
- 4.1.8 Corrosion Test** — State if intergranular corrosion test is required (Section 8).
- 4.1.9 Marking** — State if metal die identification is required on plate  $\frac{1}{4}$  in. (6.35 mm) or thicker (Section 17).
- 4.1.10 Certification or Test Reports** — State if certification or test reports are required (Section 16).

## 5. Materials and Manufacture

**5.1 Heat Treatment** — The final heat treatment shall be a solution anneal. Minor cold working such as flattening

TABLE 1  
CHEMICAL REQUIREMENTS

Element	Composition, %
Nickel	24.0–26.0
Iron	remainder <sup>4</sup>
Chromium	19.0–23.0
Molybdenum	4.3–5.0
Columbium	8 × carbon to 0.40
Carbon, max	0.04
Silicon, max	1.00
Manganese, max	2.00
Phosphorus, max	0.040
Sulfur, max	0.030
Copper, max	0.50

<sup>4</sup> Determined arithmetically by difference.

or temper rolling may be performed after the final solution annealing treatment.

NOTE — This recommended solution anneal consists of heating to a minimum temperature of 2000°F (1090°C) and cooling rapidly to room temperature.

## 6. Chemical Composition

**6.1** The material sampled, in accordance with 11.2, shall conform to the composition limits prescribed in Table 1.

**6.2** If a product analysis is subsequently made, the material shall conform to the composition limits with the product analysis variation prescribed in Table 2.

## 7. Mechanical Requirements

**7.1** The material shall conform to the requirements as to the mechanical property prescribed in Table 3.

## 8. Intergranular Corrosion Test

**8.1** All material supplied to this specification shall be capable of passing the intergranular corrosion test, but the test need not be performed on any given lot unless it is specified on the purchase order. If the test is specified, it shall be performed by the manufacturer on specimens taken in the as-shipped condition. Specimens shall be tested in the sensitized condition (1 h at 1250°F (677°C)), and tested in accordance with Practice C of Practices A 262. The corrosion rate shall not exceed 2.5 mils/month (165 mg/dm<sup>2</sup>-day).

## 9. Dimensions and Permissible Variations

**9.1 Sheet** — The material referred to as sheet shall conform to the variations in dimensions prescribed in Tables 4 to 9, inclusive.

TABLE 2  
PRODUCT (CHECK) ANALYSIS

Element	Tolerances Over the Maximum Limit or Under the Minimum Limit, %
Nickel	0.20
Chromium	0.20
Molybdenum	0.10
Columbium	0.05
Carbon	0.01
Silicon	0.05
Manganese	0.04
Phosphorus	0.005
Sulfur	0.005
Copper	0.03

**9.2 Cold-Rolled Strip** — The material referred to as cold-rolled strip shall conform to the permissible variations in dimensions prescribed in Tables 10 to 13, inclusive.

**9.3 Plate** — The material referred to as plate shall conform to the permissible variations in dimensions prescribed in Tables 14 to 19, inclusive.

### 9.4 Edges for Cold-Rolled Strip:

**9.4.1** The various types of edges procurable shall be as follows:

**9.4.1.1 No. 1 Edge** — Rolled edge, contour as specified.

**9.4.1.2 No. 3 Edge** — An edge produced by slitting.

**9.4.1.3 No. 5 Edge** — Approximately square edge produced by rolling or filing, or both, after slitting.

## 10. Workmanship, Finish, and Appearance

**10.1** The material shall be free of injurious imperfections and shall correspond to the designated finish as described as follows:

**10.1.1 Sheet** — The various types of finish procurable on sheet products shall be as follows:

**10.1.1.1 No. 1 Finish** — Hot rolled, annealed, and descaled; produced by hot rolling to specified thicknesses followed by annealing and descaling (see 10.2).

**10.1.1.2 No. 2D Finish** — Dull, cold-rolled finish; produced by cold rolling to the specified thickness, annealing, and descaling. The dull finish results from the descaling and pickling operations.

**10.1.1.3 No. 2B Finish** — Bright, cold-rolled finish; produced by giving a final light cold-rolled pass with polished rolls, to a sheet that has been annealed and descaled.

**10.1.1.4 No. 4 Finish** — General-purpose polished finish. Following initial grinding with coarser abrasives,

TABLE 3  
MECHANICAL PROPERTY REQUIREMENTS

Form	Tensile Strength, min, ksi (MPa)	Yield Strength (0.2 % offset), min, ksi (MPa)	Elongation in 2 in. or 50 mm, or 4D, min, %	Rockwell Hardness (or equivalent) <sup>A</sup>
Sheet	80 (550)	35 (240)	30	75–90 HRB
Strip	80 (550)	35 (240)	30	75–90 HRB
Plate	80 (550)	35 (240)	30	75–90 HRB

<sup>A</sup> Hardness values are shown for information only and shall not constitute a basis for acceptance or rejection as long as the other mechanical properties are met.

TABLE 4  
THICKNESS TOLERANCES FOR HOT-ROLLED AND COLD-ROLLED SHEETS

Specified Thickness, in. (mm)	Tolerance, over and under, in. (mm)
Over 0.145 to less than 0.1875 (3.68 to less than 4.76)	0.014 (0.36)
Over 0.130 to 0.145 (3.30 to 3.68), incl	0.012 (0.30)
Over 0.114 to 0.130 (2.90 to 3.30), incl	0.010 (0.25)
Over 0.098 to 0.114 (2.49 to 2.90), incl	0.009 (0.23)
Over 0.083 to 0.098 (2.11 to 2.49), incl	0.008 (0.20)
Over 0.072 to 0.083 (1.83 to 2.11), incl	0.007 (0.18)
Over 0.058 to 0.072 (1.47 to 1.83), incl	0.006 (0.15)
Over 0.040 to 0.058 (1.02 to 1.47), incl	0.005 (0.13)
Over 0.026 to 0.040 (0.66 to 1.02), incl	0.004 (0.10)
Over 0.016 to 0.026 (0.41 to 0.66), incl	0.003 (0.08)
Over 0.007 to 0.016 (0.18 to 0.41), incl	0.002 (0.05)
Over 0.005 to 0.007 (0.13 to 0.18), incl	0.0015 (0.04)
0.005 (0.13)	0.001 (0.03)

TABLE 5  
WIDTH AND LENGTH TOLERANCES FOR HOT-ROLLED  
AND COLD-ROLLED RESQUARED SHEETS  
(STRETCHER LEVELED FLATNESS)

Specified Dimensions, in. (mm)	Tolerance, in. (mm)	
	Over	Under
For thicknesses under 0.031 (0.79):		
Widths up to 48 (1219), excl	$\frac{1}{16}$ (1.6)	0
Widths 48 (1219) and over	$\frac{1}{8}$ (3.2)	0
Lengths up to 120 (3048), excl	$\frac{1}{16}$ (1.6)	0
Lengths 120 (3048) and over	$\frac{1}{8}$ (3.2)	0
For thicknesses 0.031 (0.79) and over:		
All widths and lengths	$\frac{1}{4}$ (6.4)	0

sheets are generally finished last with abrasives approximately 120 to 150 mesh. Sheets can be produced with one or two sides polished. When polished on one side only, the other side may be rough ground in order to obtain the necessary flatness.

**10.1.1.5 Bright Annealed** — Bright finish produced by cold rolling to thickness, then annealing in a protective atmosphere.

**10.1.2 Strip** — The type of finish procurable on cold-rolled strip shall be as follows:

**10.1.2.1 No. 1 Finish** — Cold rolled to specified thickness, annealed, and pickled (see 10.2). Appearance of this finish is a dull gray.

**10.1.2.2 No. 2 Finish** — Same as No. 1 finish, followed by a final light cold-rolled pass, generally on highly polished rolls.

**10.1.2.3 Bright Annealed** — Bright finish produced by cold rolling to thickness, then annealing in a protective atmosphere.

**10.1.3 Plate** — The types of finish procurable on plates shall be as follows:

**10.1.3.1 Hot- or Cold-Rolled, Annealed** — Scale not removed (see 10.2).

**10.1.3.2 Hot- or Cold-Rolled, Annealed, Descaled** — Scale removed by a blast cleaning or pickling operation (see 10.2).

**10.2 Spot grinding** to remove surface imperfections is permitted for material produced in accordance with 10.1.1.1, 10.1.2.1, 10.1.3.1, and 10.1.3.2, provided such grinding does not reduce the thickness or width at any point beyond the permissible variations in dimensions.

TABLE 6  
WIDTH, LENGTH, AND CAMBER TOLERANCES FOR HOT-ROLLED AND COLD-ROLLED SHEETS NOT RESQUARED

Width Tolerances		
Specified Thickness, in. (mm)	Tolerance for Specified Width, in. (mm)	
	24 to 48 (610 to 1219), excl	48 (1219) and Over
Less than $\frac{3}{16}$ (4.76)	$\frac{1}{16}$ (1.6) over, 0 under	$\frac{1}{8}$ in. (3.2) over, 0 under
Length Tolerances		
Specified Length, ft (mm)	Tolerance, in. (mm)	
	Over	Under
Up to 10 (3050), incl	$\frac{1}{4}$ (6.4)	0 (0)
Over 10 to 20 (3050 to 6100), incl	$\frac{1}{2}$ (12.7)	0 (0)
Camber Tolerances <sup>A</sup>		
Specified Width, in. (mm)	Tolerance per Unit Length of any 8 ft (2440 mm), in. (mm)	
24 to 36 (610 to 914), incl	$\frac{1}{8}$ (3.2)	
Over 36 (914)	$\frac{3}{32}$ (2.4)	

<sup>A</sup> Camber is the greatest deviation of a side edge from a straight line, and measurement is taken by placing an 8-ft (2440-mm) straightedge on the concave side and measuring the greatest distance between the sheet edge and the straightedge.

TABLE 7  
FLATNESS TOLERANCES FOR HOT-ROLLED AND COLD-ROLLED SHEETS

Sheets not Specified to Stretcher Level Standard of Flatness			
Specified Thickness, in. (mm)	Width, in. (mm)	Flatness Tolerance (max Deviation from a Horizontal Flat Surface), in. (mm)	
0.062 (1.57) and over	to 60 (1524), incl	$\frac{1}{2}$ (12.7)	
	over 60 to 72 (1524 to 1829), incl	$\frac{3}{4}$ (19.1)	
Under 0.062 (1.57)	over 72 (1829)	1 (25.4)	
	to 36 (914), incl	$\frac{1}{2}$ (12.7)	
	over 36 to 60 (914 to 1524), incl	$\frac{3}{4}$ (19.1)	
	over 60 (1524)	1 (25.4)	
Sheets Specified to Stretcher Level Standard of Flatness			
Specified Thickness, in. (mm)	Width, in. (mm)	Length, in. (mm)	Flatness Tolerance, in. (mm)
Under $\frac{3}{16}$ (4.76)	to 48 (1219), incl	to 96 (2438), incl	$\frac{1}{8}$ (3.2)
Under $\frac{3}{16}$ (4.76)	to 48 (1219), incl	over 96 (2438)	$\frac{1}{4}$ (6.4)
Under $\frac{3}{16}$ (4.76)	over 48 (1219)	to 96 (2438), incl	$\frac{1}{4}$ (6.4)
Under $\frac{3}{16}$ (4.76)	over 48 (1219)	over 96 (2438)	$\frac{1}{4}$ (6.4)

TABLE 8  
DIAMETER TOLERANCES FOR HOT-ROLLED AND COLD-ROLLED SHEETS, SHEARED CIRCLES

Specified Thickness, in. (mm)	Tolerance Over Specified Diameter (No Tolerance Under), in. (mm)		
	Under 30 (762)	30 to 48 (762 to 1219), incl	Over 48 (1219)
Over 0.097 (2.46)	$\frac{1}{8}$ (3.2)	$\frac{3}{16}$ (4.8)	$\frac{1}{4}$ (6.4)
Over 0.057 to 0.097 (1.45 to 2.46), incl	$\frac{3}{32}$ (2.4)	$\frac{5}{32}$ (4.0)	$\frac{7}{32}$ (5.6)
0.057 (1.45) and under	$\frac{1}{16}$ (1.6)	$\frac{1}{8}$ (3.2)	$\frac{3}{16}$ (4.8)

TABLE 9  
WEIGHT TOLERANCES FOR HOT-ROLLED AND COLD-ROLLED SHEETS

It is not practicable to produce hot-rolled and cold-rolled sheets to exact theoretical weight. Sheets of any one item of a specified thickness and size in any finish may be overweight to the following extent:

- (1) An item of five sheets or less, or an item estimated to weigh 200 lb (90.7 kg) or less, may actually weigh as much as 10% over the theoretical weight.
- (2) An item of more than five sheets and estimated to weigh more than 200 lb (90.7 kg) may actually weigh as much as  $7\frac{1}{2}\%$  over the theoretical weight.
- (3) The underweight variations for sheets are limited by the under thickness tolerances shown in Table 4.

For determining theoretical weight the factor, 42 lb/ft<sup>2</sup> · in. (0.0008 kg/cm<sup>2</sup> · mm) thickness may be used.

## 11. Sampling

**11.1 Lots of Chemical Analysis, Mechanical Testing, and Corrosion Testing:**

**11.1.1** A lot for chemical analysis shall consist of one heat.

**11.1.2 Plate** — A lot of plate for testing and inspection purposes shall consist of the products resulting from the rolling of one heat of material in the same condition and specified thickness, solution annealed by the same practice, but in no case more than 25,000 lb (11,340 kg).

**11.1.3 Sheet and Strip** — A lot of sheet or strip for testing and inspection purposes shall consist of material from one heat in the same form (sheet or strip), condition, finish, and specified thickness, solution annealed by the same practice but in no case more than 25,000 lb (11,340 kg).

**11.2 Sampling for Chemical Analysis:**

**11.2.1** A representative sample shall be taken from each lot during pouring or subsequent processing.

**11.2.2** Product analysis, if performed, shall be wholly the responsibility of the purchaser.

## 11.3 Sampling for Mechanical Tests:

**11.3.1** A sample of the material to provide test specimens for mechanical tests shall be taken from such a location in each lot as to be representative of that lot.

**11.3.2** When samples are to be taken after delivery, the purchaser of material ordered to cut lengths may request on the purchase order additional material of adequate size to provide sample coupons for inspection purposes.

**11.4 Sampling for Corrosion Tests** — A sample for corrosion testing shall be taken from a location chosen to be representative of the lot.

## 12. Number of Tests and Retests

**12.1** In the case of sheet or strip supplied in coil form, two or more tension tests (one from each end of each coil), and one or more hardness tests shall be made on specimens taken from each end of the coil. When material is supplied in flat sheet, flat strip, or plate, one tension and one or more hardness tests shall be made on each 100 or less sheets, strips, or plates of the same lot. When specified, one corrosion test shall be conducted for each lot.

**12.2** If any specimens selected to represent any lot fail to meet any of the test requirements, the material represented by such specimens may be retested. If there is valid reason to believe the result is not representative, the material may be re-annealed and retested.

## 13. Specimen Preparation

**13.1** Tension test specimens from material under  $\frac{1}{2}$  in. (12.7 mm) in thickness shall be of the full thickness of the material and machined to the form and dimensions shown for the sheet-type specimen in Test Methods E 8. Tension test specimens from material  $\frac{1}{2}$  in. (12.7 mm) and over shall be of the full thickness of the material, machined to the form and dimensions shown for the plate-type specimen in Test Methods E 8, or shall be the largest possible round

TABLE 10  
THICKNESS TOLERANCES<sup>A,B,C</sup> FOR COLD-ROLLED STRIP FOR THE THICKNESSES AND WIDTHS GIVEN, OVER AND UNDER

Specified Thickness, in.	Width, in.							
	0.187 to 1, incl	Over 1 to 3, incl	Over 3 to 6, incl	Over 6 to 9, incl	Over 9 to 12, incl	Over 12 to 16, incl	Over 16 to 20, incl	Over 20 to 24, incl
Over 0.160 to less than 0.1875	0.002	0.003	0.004	0.004	0.004	0.005	0.006	0.006
Over 0.099 to 0.160, incl	0.002	0.002	0.003	0.003	0.004	0.004	0.005	0.005
Over 0.068 to 0.099, incl	0.002	0.002	0.003	0.003	0.003	0.004	0.004	0.004
Over 0.049 to 0.068, incl	0.002	0.002	0.003	0.003	0.003	0.003	0.004	0.004
Over 0.039 to 0.049, incl	0.002	0.002	0.0025	0.003	0.003	0.003	0.004	0.004
Over 0.034 to 0.039, incl	0.002	0.002	0.0025	0.0025	0.003	0.003	0.003	0.003
Over 0.028 to 0.034, incl	0.0015	0.0015	0.002	0.002	0.0025	0.0025	0.003	0.003
Over 0.025 to 0.028, incl	0.001	0.0015	0.0015	0.002	0.002	0.002	0.0025	0.003
Over 0.019 to 0.025, incl	0.001	0.001	0.0015	0.0015	0.002	0.002	0.0025	0.0025
Over 0.016 to 0.019, incl	0.001	0.001	0.001	0.0015	0.0015	0.002	0.002	0.002
Over 0.012 to 0.016, incl	0.001	0.001	0.001	0.001	0.0015	0.0015	0.002	0.002
Over 0.011 to 0.012, incl	0.001	0.001	0.001	0.001	0.0015	0.0015	0.0015	0.0015
Over 0.010 to 0.011, incl	0.001	0.001	0.001	0.001	0.001	0.0015	0.0015	0.0015
0.010	0.001	0.001	0.001	0.001	0.001	0.001	0.0015	0.0015

Specified Thickness, mm	Width, mm							
	4.76 to 25.4, incl	Over 25.4 to 76.2, incl	Over 76.2 to 152.4, incl	Over 152.4 to 228.6, incl	Over 228.6 to 304.8, incl	Over 304.8 to 406.4, incl	Over 406.4 to 508, incl	Over 508 to 609.6, incl
Over 4.06 to less than 4.75	0.05	0.08	0.10	0.10	0.10	0.13	0.15	0.15
Over 2.51 to 4.06, incl	0.05	0.05	0.08	0.08	0.10	0.10	0.13	0.13
Over 1.73 to 2.51, incl	0.05	0.05	0.08	0.08	0.08	0.10	0.10	0.10
Over 1.24 to 1.73, incl	0.05	0.05	0.08	0.08	0.08	0.08	0.10	0.10
Over 0.99 to 1.24, incl	0.05	0.05	0.06	0.08	0.08	0.08	0.10	0.10
Over 0.86 to 0.99, incl	0.05	0.05	0.06	0.06	0.08	0.08	0.08	0.08
Over 0.71 to 0.86, incl	0.04	0.04	0.05	0.05	0.06	0.06	0.08	0.08
Over 0.64 to 0.71, incl	0.02	0.04	0.04	0.05	0.05	0.05	0.06	0.08
Over 0.48 to 0.64, incl	0.02	0.02	0.04	0.04	0.05	0.05	0.06	0.06
Over 0.41 to 0.48, incl	0.02	0.02	0.02	0.04	0.04	0.05	0.05	0.05
Over 0.30 to 0.41, incl	0.02	0.02	0.02	0.02	0.04	0.04	0.05	0.05
Over 0.28 to 0.30, incl	0.02	0.02	0.02	0.02	0.04	0.04	0.04	0.04
Over 0.25 to 0.28, incl	0.02	0.02	0.02	0.02	0.02	0.04	0.04	0.04
0.25	0.02	0.02	0.02	0.02	0.02	0.02	0.04	0.04

<sup>A</sup> For thicknesses under 0.010 to 0.005 in. (0.254 to 0.127 mm), incl, in widths up to and including 16 in. (406 mm), a tolerance of  $\pm 10\%$  of the thickness applies. For thicknesses under 0.010 to 0.005 in. (0.254 to 0.127 mm), incl, in widths over 16 to 24 in. (406 to 610 mm), excl, a tolerance of  $\pm 15\%$  of the thickness applies. For thickness tolerances on thicknesses under 0.005 in. (0.127 mm) in widths up to 24 in. (610 mm), excl, the producer should be consulted.

<sup>B</sup> Thickness measurements are taken  $\frac{3}{8}$  in. (9.5 mm) in from the edge of the strip, except that on widths less than 1 in. (25.4 mm) the tolerances are applicable for measurements at all locations.

<sup>C</sup> The tolerances in this table do not include crown tolerances

TABLE 11  
CROWN TOLERANCES FOR COLD-ROLLED STRIP

Specified Thickness, in. (mm)	Additional Thickness, at Middle of Strip Over That Shown in Table 10 for Edge Measurement, for Widths and Thicknesses Given, in. (mm)		
	Width, in. (mm)		
	To 5 (127), incl	Over 5 to 12 (127 to 305), incl	Over 12 to 24 (305 to 610), excl
0.005 to 0.010 (0.127 to 0.254), incl	0.0075 (0.19)	0.001 (0.02)	0.0015 (0.04)
Over 0.010 to 0.025 (0.254 to 0.635), incl	0.001 (0.02)	0.0015 (0.04)	0.002 (0.05)
Over 0.025 to 0.065 (0.635 to 1.65), incl	0.0015 (0.04)	0.002 (0.05)	0.0025 (0.06)
Over 0.065 to 0.1875 (1.65 to 4.76), excl	0.002 (0.05)	0.0025 (0.06)	0.003 (0.08)

specimen shown in Test Methods E 8. Tension test specimens shall be taken from material after final heat treatment and shall be selected in the transverse direction unless prohibited by width.

**13.2** Corrosion test specimens shall be prepared so that at least one major surface represents the as-supplied surface, with only light surface grinding permitted on this surface.

#### 14. Test Methods

**14.1** Determine the chemical composition and properties of the material as enumerated in this specification, in case of disagreement, in accordance with the following methods:

Test	ASTM Designations
Chemical analysis	E 350, E 353 <sup>A,B</sup>
Tension	E 8
Brinell hardness	E 10
Rockwell hardness	E 18
Hardness conversion	E 140
Rounding procedure	E 29
Method of sampling for product analysis	E 55
Intergranular corrosion test	A 262, Practice C

<sup>A</sup> Iron shall be determined arithmetically by difference.

<sup>B</sup> Test Methods E 350 are to be used only for elements not covered by Test Methods E 353.

**14.2** For purpose of determining compliance with the limits in this specification, an observed value or a calculated value shall be rounded as indicated in accordance with the rounding method of Practice E 29.

Requirements	Rounded Unit for Observed or Calculated Value
Chemical composition hardness and tolerance (when expressed in decimals)	Nearest unit in the last right-hand place of figures of the specified limit
Tensile strength and yield strength	nearest 1000 psi (7 MPa)
Elongation	nearest 1%

#### 15. Rejection and Rehearing

**15.1** Material that fails to conform to the requirements of this specification may be rejected. Rejection should be reported to the producer or supplier promptly and in writing. In case of dissatisfaction with the results of the test, the producer or supplier may make claim for a rehearing.

#### 16. Certification

**16.1** When specified in the purchase order or contract, a manufacturer's certification shall be furnished to the purchaser stating that material has been manufactured, tested, and inspected in accordance with this specification, and that the test results on representative samples meet specification requirements. When specified in the purchase order or contract, a report of the test results shall be furnished.

#### 17. Product Marking

**17.1** Each piece (plate, sheet, strip, or coil) shall be marked legibly with the specification number, UNS number, heat number, and the name of the manufacturer. When specified, marking shall be by die stamping on plates  $\frac{1}{4}$  in. (6.35 mm) or thicker.

TABLE 12  
WIDTH TOLERANCES FOR COLD-ROLLED STRIP ON EDGE NOS. 1, 5, and 3

Edge Nos. 1 and 5				
Specified Edge No.	Width, in.	Thickness, in.	Width Tolerance for Thickness and Width Given, in.	
			Over	Under
1 and 5	$\frac{9}{32}$ and under	$\frac{1}{16}$ and under	0.005	0.005
1 and 5	over $\frac{9}{32}$ to $\frac{3}{4}$ , incl	$\frac{3}{32}$ and under	0.005	0.005
1 and 5	over $\frac{3}{4}$ to 5, incl	$\frac{1}{8}$ and under	0.005	0.005
5	over 5 to 9, incl	$\frac{1}{8}$ to 0.008, incl	0.010	0.010
5	over 9 to 20, incl	0.105 to 0.015	0.010	0.010
5	over 20 to $23\frac{15}{16}$ , incl	0.080 to 0.023	0.015	0.015

Edge No. 3						
Specified Thickness, in.	Width Tolerance for Thickness and Width Given, Over and Under, in.					
	Under $\frac{1}{2}$ to $\frac{3}{16}$ , incl	$\frac{1}{2}$ to 6, incl	Over 6 to 9, incl	Over 9 to 12, incl	Over 12 to 21, incl	Over 21 to 24, incl
Under 0.1875 to 0.161, incl	...	0.016	0.020	0.020	0.031	0.031
0.160 to 0.100, incl	0.010	0.010	0.016	0.016	0.020	0.020
0.099 to 0.069, incl	0.008	0.008	0.010	0.010	0.016	0.020
0.068 and under	0.005	0.005	0.005	0.010	0.016	0.020

Edge Nos. 1 and 5				
Specified Edge No.	Width, mm	Thickness, mm	Width Tolerance for Thickness and Width Given, mm	
			Over	Under
1 and 5	7.1 and under	1.6 and under	0.13	0.13
1 and 5	Over 7.1 to 19.0, incl	2.4 and under	0.13	0.13
1 and 5	Over 19.0 to 127	3.2 and under	0.13	0.13
5	Over 127 to 229	3.2 to 0.203, incl	0.25	0.25
5	Over 229 to 508	2.7 to 0.381, incl	0.25	0.25
5	Over 508 to 608	2.0 to 0.584, incl	0.38	0.38

Edge No. 3						
Specified Thickness, mm	Width Tolerance for Thickness and Width Given, Over and Under, mm					
	Under 12.7 to 4.76, incl	12.7 to 152, incl	Over 152 to 229, incl	Over 229 to 305, incl	Over 305 to 533, incl	Over 533 to 610, excl
Under 4.76 to 4.09, incl	...	0.41	0.51	0.51	0.79	0.79
4.06 to 2.54, incl	0.25	0.25	0.41	0.41	0.51	0.51
2.51 to 1.75, incl	0.20	0.20	0.25	0.25	0.41	0.51
1.73 and under	0.13	0.13	0.13	0.25	0.41	0.51

TABLE 13  
LENGTH AND CAMBER<sup>A</sup> TOLERANCES FOR COLD-ROLLED STRIP

Length Tolerances	
Specified Length, ft (mm)	Tolerance Over Specified Length (No Under Tolerance), in. (mm)
To 5 (1524), incl	$\frac{3}{8}$ (9.5)
Over 5 to 10 (1520 to 3050), incl	$\frac{1}{2}$ (12.7)
Over 10 to 20 (3050 to 6100), incl	$\frac{5}{8}$ (15.9)
Camber Tolerances	
Specified Width, in. (mm)	Tolerance per Unit Length of any 8 ft (2440 mm), in. (mm)
To $1\frac{1}{2}$ (38.1), incl	$\frac{1}{2}$ (12.7)
Over $1\frac{1}{2}$ to 24 (38.1 to 610), excl	$\frac{1}{4}$ (6.4)

<sup>A</sup> Camber is the deviation of a side edge from a straight line, and measurement is taken by placing an 8-ft straightedge on the concave side and measuring the greatest distance between the strip edge and the straightedge.

TABLE 14  
THICKNESS<sup>A</sup> TOLERANCES ON PLATES<sup>B,C</sup>

Specified Thickness, in. (mm)	Width, in. (mm) Tolerance Over Specified Thickness, in. (mm)			
	To 84 (2134), incl	Over 84 to 120 (2134 to 3048), incl	Over 120 to 144 (3048 to 3658), incl	Over 144 (3658)
$\frac{3}{16}$ to $\frac{3}{8}$ (4.76 to 9.53), excl	0.046 (1.17)	0.050 (1.27)		
$\frac{3}{8}$ to $\frac{3}{4}$ (9.53 to 19.05), excl	0.054 (1.37)	0.058 (1.47)	0.075 (1.91)	0.090 (2.29)
$\frac{3}{4}$ to 1 (19.05 to 25.4), excl	0.060 (1.52)	0.064 (1.63)	0.083 (2.11)	0.100 (2.54)
1 to 2 (25.4 to 50.8), incl	0.070 (1.78)	0.074 (1.88)	0.095 (2.41)	0.115 (2.92)

<sup>A</sup> Thickness is measured along the longitudinal edges of the plate at least  $\frac{3}{8}$  in. (9.53 mm), but not more than 3 in. (76.20 mm), from the edge.

<sup>B</sup> For circles, the above over-thickness tolerances apply to the diameter of the circle corresponding to the width ranges shown. For plates of irregular shape, the above over-thickness tolerances apply to the greatest width corresponding to the width ranges shown.

<sup>C</sup> For plates up to 2 in. (50.8 mm), incl, in thickness, the tolerance under specified thickness is 0.01 in. (0.254 mm).

TABLE 15  
WIDTH AND LENGTH TOLERANCES FOR PLATES<sup>A,B</sup>

		Tolerance Over Specified Width and Length for Given Width, Length, and Thickness, in.					
Width, in.	Length, in.	Under 3/8 in.		3/8 to 1/2, incl, in Thickness		Over 1/2 in Thickness	
		Width	Length	Width	Length	Width	Length
48 and under	144 and under	1/8	3/16	3/16	1/4	5/16	3/8
Over 48 to 60, incl		3/16	1/4	1/4	3/16	3/8	7/16
Over 60 to 84, incl		1/4	5/16	5/16	3/8	7/16	1/2
Over 84 to 108, incl		5/16	3/8	3/8	7/16	1/2	9/16
Over 108		3/8	7/16	7/16	1/2	5/8	11/16
48 and under	over 144 to 240	3/16	3/8	1/4	1/2	5/16	5/8
Over 48 to 60, incl		1/4	7/16	5/16	5/8	3/8	3/4
Over 60 to 84, incl		3/8	1/2	7/16	11/16	7/8	3/4
Over 84 to 108, incl		7/16	9/16	1/2	3/4	7/8	7/8
Over 108		1/2	5/8	5/8	7/8	11/16	1
48 and under	over 240 to 360	1/4	1/2	5/16	5/8	3/8	3/4
Over 48 to 60, incl		5/16	5/8	3/8	3/4	1/2	3/4
Over 60 to 84, incl		7/16	11/16	1/2	3/4	5/8	7/8
Over 84 to 108, incl		9/16	3/4	5/8	7/8	3/4	1
Over 108		5/8	7/8	11/16	1	7/8	1
60 and under	over 360 to 480	7/16	1 1/8	1 1/2	1 1/4	5/8	1 3/8
Over 60 to 84, incl		1/2	1 1/4	5/8	1 3/8	3/4	1 1/2
Over 84 to 108, incl		9/16	1 1/4	3/4	1 3/8	7/8	1 1/2
Over 108		3/4	1 3/8	7/8	1 1/2	1	1 5/8
60 and under	over 480 to 600	7/16	1 1/4	1 1/2	1 1/2	5/8	1 5/8
Over 60 to 84, incl		1/2	1 3/8	5/8	1 1/2	3/4	1 5/8
Over 84 to 108, incl		5/8	1 3/8	1	1 1/2	7/8	1 5/8
Over 108		3/4	1 1/2	7/8	1 5/8	1	1 3/4
60 and under	over 600	1/2	1 3/4	5/8	1 7/8	3/4	1 7/8
Over 60 to 84, incl		5/8	1 3/4	3/4	1 7/8	7/8	1 7/8
Over 84 to 108, incl		5/8	1 3/4	3/4	1 7/8	7/8	1 7/8
Over 108		7/8	1 3/4	1	2	1 1/8	2 1/4

		Tolerance Over Specified Width and Length for Given Width, Length, and Thickness, mm					
Width, mm	Length, mm	Under 9.5 mm		9.5 to 12.7 mm incl, in Thickness		Over 12.7 mm in Thickness	
		Width	Length	Width	Length	Width	Length
1219 mm and under	3658 and under	3.2	4.8	4.8	6.4	7.9	9.5
Over 1219 to 1524, incl		4.8	6.4	6.4	7.9	9.5	11.1
Over 1524 to 2134, incl		6.4	7.9	7.9	9.5	11.1	12.7
Over 2134 to 2743, incl		7.9	9.5	9.5	11.1	12.7	14.3
Over 2743		9.5	11.1	11.1	12.7	15.9	17.5
1219 mm and under	over 3658 to 6096	4.8	9.5	6.4	12.7	7.9	15.9
Over 1219 to 1524, incl		6.4	11.1	7.9	15.9	9.5	19.1
Over 1524 to 2134, incl		9.5	12.7	11.1	17.5	12.7	19.1
Over 2134 to 2743, incl		11.1	14.3	12.7	19.1	15.9	22.2
Over 2743		12.7	15.9	15.9	22.2	17.5	25.4
1219 mm and under	over 6096 to 9144	6.4	12.7	7.9	15.9	9.5	19.1
Over 1219 to 1524, incl		7.9	15.9	9.5	19.1	12.7	19.1
Over 1524 to 2134, incl		11.1	17.5	12.7	19.1	15.9	22.2
Over 2134 to 2743, incl		14.3	19.1	15.9	22.2	19.1	25.4
Over 2743		15.9	22.2	17.5	25.4	22.2	25.4
1524 mm and under	over 9144 to 12 192	11.1	28.6	12.7	31.8	15.9	34.9
Over 1524 to 2134, incl		12.7	31.8	15.9	34.9	19.1	38.1
Over 2134 to 2743, incl		14.3	31.8	19.1	34.9	22.2	38.1
Over 2743		19.1	34.9	22.2	38.1	25.4	41.3
1524 mm and under	over 12 192 to 15 240	11.1	31.8	12.7	38.1	19.1	41.3
Over 1524 to 2134, incl		12.7	34.9	15.9	38.1	22.2	41.3
Over 2134 to 2743, incl		15.9	34.9	19.1	38.1	22.2	41.3
Over 2743		19.1	38.1	22.2	41.3	25.4	44.5
1524 mm and under	over 15 240	12.7	44.5	15.9	47.6	19.1	47.6
Over 1524 to 2134, incl		15.9	44.5	19.1	47.6	22.2	47.6
Over 2134 to 2743, incl		15.9	44.5	19.1	47.6	22.2	47.6
Over 2743		22.2	44.5	25.4	50.8	28.6	57.2

<sup>A</sup> The tolerance under specified width and length is 1/4 in. (6.35 mm).

<sup>B</sup> Rectangular plates over 1 in. (25.4 mm) in thickness are not commonly sheared and are machined or otherwise cut to length and width or produced in the size as rolled, uncropped.

**TABLE 16  
CAMBER TOLERANCE FOR PLATES**

Maximum camber<sup>4</sup> = 1/8 in. (3.2 mm) in any 5 ft (1524 mm)

<sup>4</sup> Camber is the deviation of a side edge from a straight line, and measurement is taken by placing a 5-ft (1524-mm) straight-edge on the concave side and measuring the greatest distance between the plate and the straightedge.

**TABLE 17  
DIAMETER TOLERANCES FOR CIRCULAR PLATES**

Specified Diameter, in. (mm)	Tolerance over Specified Diameter for Given Diameter and Thickness (No Under Tolerance), in. (mm)		
	Thickness		
	To 0.375 (9.53), excl	0.375 to 0.625 (9.53 to 15.88), excl	0.625 (15.88) and over
To 60 (1524), excl	1/4 (6.4)	3/8 (9.5)	1/2 (12.7)
60 to 84 (1524 to 2134), excl	5/16 (7.9)	7/16 (11.1)	9/16 (14.3)
84 to 108 (2134 to 2743), excl	3/8 (9.5)	1/2 (12.7)	5/8 (15.9)
108 to 130 (2743 to 3302), excl	7/16 (11.1)	9/16 (14.3)	11/16 (17.5)

TABLE 18  
FLATNESS TOLERANCES FOR PLATES

Flatness Tolerance (Deviation from a Flat Horizontal Surface) for Thickness and Width Given, in.									
Specified Thickness, in.	Width, in.								
	48 and Under	Over 48 to 60, excl	60 to 72, excl	72 to 84, excl	84 to 96, excl	96 to 108, excl	108 to 120, excl	120 to 144, excl	144 and Over
$\frac{3}{16}$ to $\frac{1}{4}$ , excl	$\frac{3}{4}$	$1\frac{1}{16}$	$1\frac{1}{4}$	$1\frac{3}{8}$	$1\frac{5}{8}$	$1\frac{5}{8}$	$1\frac{7}{8}$	2	...
$\frac{1}{4}$ to $\frac{3}{8}$ , excl	$1\frac{1}{16}$	$\frac{3}{4}$	$1\frac{15}{16}$	$1\frac{1}{8}$	$1\frac{3}{8}$	$1\frac{7}{16}$	$1\frac{9}{16}$	$1\frac{7}{8}$	...
$\frac{3}{8}$ to $\frac{1}{2}$ , excl	$\frac{1}{2}$	$\frac{9}{16}$	$1\frac{11}{16}$	$\frac{3}{4}$	$1\frac{15}{16}$	$1\frac{1}{8}$	$1\frac{1}{4}$	$1\frac{7}{16}$	$1\frac{3}{4}$
$\frac{1}{2}$ to $\frac{3}{4}$ , excl	$\frac{1}{2}$	$\frac{9}{16}$	$\frac{5}{8}$	$\frac{5}{8}$	$\frac{3}{16}$	$1\frac{1}{8}$	$1\frac{1}{8}$	$1\frac{1}{8}$	$1\frac{3}{8}$
$\frac{3}{4}$ to 1, excl	$\frac{1}{2}$	$\frac{9}{16}$	$\frac{5}{8}$	$\frac{5}{8}$	$\frac{3}{4}$	$\frac{3}{16}$	$1\frac{15}{16}$	1	$1\frac{1}{8}$
1 to $1\frac{1}{2}$ , excl	$\frac{1}{2}$	$\frac{9}{16}$	$\frac{9}{16}$	$\frac{9}{16}$	$1\frac{11}{16}$	$1\frac{11}{16}$	$1\frac{11}{16}$	$\frac{3}{4}$	1
$1\frac{1}{2}$ to 4, excl	$\frac{3}{16}$	$\frac{5}{16}$	$\frac{3}{8}$	$\frac{7}{16}$	$\frac{1}{2}$	$\frac{9}{16}$	$\frac{5}{8}$	$\frac{3}{4}$	$\frac{7}{8}$
4 to 6, excl	$\frac{1}{4}$	$\frac{3}{8}$	$\frac{1}{2}$	$\frac{9}{16}$	$\frac{5}{8}$	$\frac{3}{4}$	$\frac{7}{8}$	1	$1\frac{1}{8}$

Flatness Tolerance (Deviation from a Flat Horizontal Surface) for Thickness and Width Given, mm									
Specified Thickness, mm	Width, mm								
	1219 and Under	Over 1219 to 1524, excl	1524 to 1829, excl	1829 to 2134, excl	2134 to 2438, excl	2438 to 2743, excl	2743 to 3048, excl	3048 to 3658, excl	3658 and Over
4.76 to 6.35, excl	19.1	27.0	31.8	34.9	41.3	41.3	47.6	50.8	
6.35 to 9.53, excl	17.5	19.1	23.8	28.6	34.9	36.5	39.7	47.6	
9.53 to 12.7, excl	12.7	14.3	17.5	19.1	23.8	28.6	31.8	36.5	44.5
12.7 to 19.05, excl	12.7	14.3	15.9	15.9	20.6	28.6	28.6	28.6	34.9
19.05 to 25.4, excl	12.7	14.3	15.9	15.9	19.1	20.6	23.8	25.4	28.6
25.4 to 38.1, excl	12.7	14.3	14.3	14.3	17.5	17.5	17.5	19.1	25.4
38.1 to 102, excl	4.8	7.9	9.5	11.1	12.7	14.3	15.9	19.1	22.2
102 to 152, excl	6.4	9.5	12.7	14.3	15.9	19.1	22.2	25.4	28.6

TABLE 19  
RECOMMENDED PLATE FLAME-CUTTING  
TOLERANCES TO CLEANUP IN MACHINING

Specified Thickness, in. (mm)	Machining Allowance per Edge, in. (mm)
2 (51) and under	$\frac{1}{4}$ (6.4)
Over 2 to 3 (51 to 76), incl	$\frac{3}{8}$ (9.5)
Over 3 to 6 (76 to 152), incl	$\frac{1}{2}$ (12.7)

TABLE 20  
ABRASIVE-CUTTING WIDTH AND LENGTH TOLERANCES

Specified Thickness, in. (mm)	Tolerance Over <sup>4</sup> Specified Width and Length, in. (mm)	
	Width	Length
Up to $1\frac{1}{4}$ (32)	$\frac{1}{8}$ (3.2)	$\frac{1}{8}$ (3.2)
Over $1\frac{1}{4}$ to $2\frac{3}{4}$ (32 to 70)	$\frac{3}{16}$ (4.8)	$\frac{3}{16}$ (4.8)

<sup>4</sup> The tolerance under the specified width and length is  $\frac{1}{8}$  in. (3.2 mm).

ASMEENORMDOC.COM : Click to view the full PDF of ASME BPVC.II.B (ASME BPVC Section II part B) 2025

# SPECIFICATION FOR WELDED NICKEL AND NICKEL-COBALT ALLOY PIPE



**SB-619/SB-619M**

(Identical with ASTM Specification B619/B619M-17 except certification and test reports have been made mandatory per SB-775.)

ASMENORMDOC.COM : Click to view the full PDF of ASME BPVC.II.B (ASME BPVC Section II part B) 2025

# Specification for Welded Nickel and Nickel-Cobalt Alloy Pipe

## 1. Scope

1.1 This specification covers welded pipe of nickel and nickel-cobalt alloys (UNS N10001; UNS N10242; UNS N10665; UNS N12160; UNS N10624; UNS N10629; UNS N10675; UNS N10276; UNS N06455; UNS N06007; UNS N06975; UNS N08320; UNS N06002; UNS N06022; UNS N06035; UNS N06044; UNS N06058; UNS N06059; UNS N06200; UNS N10362; UNS N06985; UNS N06030; UNS R30556; UNS N08031; UNS N06230; UNS N06686; UNS N06210; and UNS R20033) as shown in Table 1.

1.2 This specification covers pipe in Schedules 5S, 10S, 40S, and 80S through 8-in. nominal pipe size and larger as set forth in ANSI B36.19 (see Table 2).

1.3 Two classes of pipe are covered as follows:

1.3.1 *Class I*—As welded and solution annealed or welded and sized and solution annealed.

1.3.2 *Class II*—Welded, cold worked, and solution annealed.

1.4 All pipe shall be furnished in the solution annealed and descaled condition. When atmosphere control is used, descaling is not necessary.

1.5 The values stated in either SI units or inch-pound units are to be regarded separately as standard. The values stated in each system may not be exact equivalents; therefore, each system shall be used independently of the other. Combining values from the two systems may result in non-conformance with the standard.

1.6 *This standard does not purport to address all of the safety concerns, if any, associated with its use. It is the responsibility of the user of this standard to become familiar with all hazards including those identified in the appropriate Safety Data Sheet (SDS) for this product/material as provided*

*by the manufacturer, to establish appropriate safety and health practices, and determine the applicability of regulatory limitations prior to use.*

1.7 *This international standard was developed in accordance with internationally recognized principles on standardization established in the Decision on Principles for the Development of International Standards, Guides and Recommendations issued by the World Trade Organization Technical Barriers to Trade (TBT) Committee.*

## 2. Referenced Documents

### 2.1 ASTM Standards:

B775 Specification for General Requirements for Nickel and Nickel Alloy Welded Pipe

B899 Terminology Relating to Non-ferrous Metals and Alloys

E527 Practice for Numbering Metals and Alloys in the Unified Numbering System (UNS)

### 2.2 ANSI Standards:

B36.19 Stainless Steel Pipe

B2.1 Pipe Threads

### 2.3 ASME Boiler and Pressure Vessel Code

Section IX Welding and Brazing Qualifications

## 3. Terminology

3.1 For definitions of terms used in this standard refer to Terminology B899.

## 4. General Requirement

4.1 Material furnished under this specification shall conform to the applicable requirements of Specification B775 unless otherwise provided herein.

## 5. Ordering Information

5.1 It is the responsibility of the purchaser to specify all requirements that are necessary for material ordered under this

TABLE 1 Chemical Requirements

	Composition Limits, %																								
	Ni	Cr	Mo	Fe	W	C	Si max	Co	Mn	V	P max	S max	Ti	Cu	Cb (Nb) +Ta	Al	Zr	La	N	B	Cb (Nb)	Ta	Ni+ Mo	Mg	
Ni-Mo Alloys N10001	remainder <sup>A</sup>	1.0 max 30.0	26.0- 30.0	4.0-6.0	...	0.05 max	1.0	2.5 max	1.0 max	0.2- 0.4	0.04	0.03	...	...	...										
N10665	remainder <sup>A</sup>	1.0 max 30.0	26.0- 30.0	2.0 max	...	0.02 max	0.10	1.0 max	1.0 max	...	0.04	0.03	...	...	...										
N10675	65.0 min	1.0- 3.0	27.0- 32.0	1.0-3.0	3.0 max	0.01 max	0.10	3.0 max	3.0 max	0.20 max	0.030	0.010	0.20 max	0.20 max	...	0.50	0.10 max	...	...	...	0.20 max	0.20 max	94.0- 98.0		
N10629	remainder <sup>A</sup>	0.5- 1.5	26.0- 30.0	1.0-6.0	...	0.01 max	0.05	2.5 max	1.5 max	...	0.04	0.01	...	0.5 max	...	0.1- 0.5	...	...	...	...	...	...	...	...	
N10624	remainder <sup>A</sup>	6.0- 10.0	21.0- 25.0	5.0-8.0	...	0.01 max	0.10	1.0 max	1.0 max	...	0.025	0.01	...	0.5 max	...	...	...	...	...	...	...	...	...	...	
Ni-Mo-Cr-Fe Alloy N10242	remainder <sup>A</sup>	7.0- 9.0	24.0- 26.0	2.0 max		0.03 max	0.80	1.00 max	0.80 max		0.030	0.015		0.50 max		0.50 max					0.006 max				
Low C Ni- Cr-Mo Alloys N10276	remainder <sup>A</sup>	14.5- 16.5	15.0- 17.0	4.0-7.0	3.0- 4.5	0.010 max	0.08	2.5 max	1.0 max	0.35 max	0.04	0.03	...	...	...										
N06022	remainder <sup>A</sup>	20.0- 22.5	12.5- 14.5	2.0-6.0	2.5- 3.5	0.015 max	0.08	2.5 max	0.5 max	0.35 max	0.02	0.02	...	...	...										
N06035	remainder <sup>A</sup>	32.25- 34.25	7.60- 9.00	2.00 max	0.60 max	0.050 max	0.60	1.00 max	0.50 max	0.20 max	0.030	0.015	...	0.30 max	...	0.40 max									
N06044	balance	43.5- 45.3	0.80- 1.20	0.3 max	...	0.02 max	0.20	...	0.07- 0.30	...	0.020	0.020	0.10- 0.30	...	...	0.30 max									...
N06058	balance	20.0- 23.0	18.5- 21.0	1.5 max	0.3 max	0.010 max	0.10	0.3 max	0.50 max	...	0.015	0.010	...	0.50 max	...	0.40 max				0.02- 0.15					
N06059	balance	22.0- 24.0	15.0- 16.5	1.5 max	...	0.010 max	0.10	0.3 max	0.5 max	...	0.015	0.010	...	0.50 max	...	0.1- 0.4									
N06455	remainder <sup>A</sup>	14.0- 18.0	14.0- 17.0	3.0 max	...	0.015 max	0.08	2.0 max	1.0 max	...	0.04	0.03	0.70 max	...	...										
Ni-Cr-Fe- Mo-Cu Alloys																									
N06007	remainder <sup>A</sup>	21.0- 23.5	5.5- 7.5	18.0-21.0	1.0 max	0.05 max	1.0	2.5 max	1.0- 2.0	...	0.04	0.03	...	1.5- 2.5	1.75- 2.5										
N06975	47.0-52.0	23.0- 26.0	5.0- 7.0	remainder	...	0.03 max	1.0	...	1.0 max	...	0.03	0.03	0.70- 1.50	0.70- 1.20	...										
N06985	remainder <sup>A</sup>	21.0- 23.5	6.0- 8.0	18.0-21.0	1.5 max	0.015 max	1.0	5.0 max	1.0 max	...	0.04	0.03	...	1.5- 2.5	0.50 max										
N06030	remainder <sup>A</sup>	28.0- 31.5	4.0- 6.0	13.0-17.0	1.5- 4.0	0.03 max	0.8	5.0 max	1.5 max	...	0.04	0.02	...	1.0- 2.4	0.30- 1.50										
Ni-Fe-Cr-Mo Alloys																									
N08320	25.0-27.0	21.0- 23.0	4.0- 6.0	remainder	...	0.05 max	1.0	...	2.5 max	...	0.04	0.03	4xC min	...	...										
Ni-Cr-Mo-Fe Alloy N06002	remainder <sup>A</sup>	20.5- 23.0	8.0- 10.0	17.0-20.0	0.20- 1.0	0.05- 0.15	1.0	0.5- 2.5	1.0 max	...	0.04	0.03	...	...	...										
Ni-Fe-Cr-Co Alloy R30556	19.0-22.5	21.0- 23.0	2.5- 4.0	remainder	2.0- 3.5	0.05- 0.15	0.20- 0.80	16.0- 21.0	0.50- 2.00	...	0.04	0.015	...	...	...	0.10- 0.50	0.001- 0.10	0.005- 0.10	0.10- 0.30	0.02 max	0.30 max	0.3- 1.25			

ASMENORMDOC.COM · Click to view the full PDF of ASME BPVC.II.B (ASME BPVC Section II Part B) 2025

TABLE 1 Continued

Composition Limits, %																								
	Ni	Cr	Mo	Fe	W	C	Si max	Co	Mn	V	P max	S max	Ti	Cu	Cb (Nb) +Ta	Al	Zr	La	N	B	Cb (Nb)	Ta	Ni+ Mo	Mg
Ni-Cr-W-Mo Alloy N06230	remainder <sup>4</sup>	20.0-24.0	1.0-3.0	3.0 max	13.0-15.0	0.05-0.15	0.25-0.75	5.0 max	0.30-1.00	...	0.03	0.015	...	...	...	0.50 max	...	0.005-0.050	...	0.015 max	...	...	...	...
Low C-Ni-Cr-Mo-Cu Alloy N06200	remainder <sup>4</sup>	22.0-24.0	15.0-17.0	3.0 max	...	0.010 max	0.08	2.0 max	0.50 max	...	0.025	0.010	...	1.3-1.9	...	0.50 max	...	...	...	...	...	...	...	...
Low-C-Ni-Mo-Cr Alloy N10362	remainder <sup>4</sup>	13.8-15.6	21.5-23.0	1.25 max	...	0.010 max	0.08	...	0.60 max	...	0.025	0.010	...	...	...	0.50 max	...	...	...	...	...	...	...	...
Low C-Ni-Fe-Cr-Mo-Cu Alloy N08031	30.0-32.0	26.0-28.0	6.0-7.0	balance	...	0.015 max	0.3	...	2.0 max	...	0.020	0.010	...	1.0-1.4	...	...	...	...	0.15-0.25	...	...	...	...	...
Low C-Ni-Cr-Mo-W Alloy N06686	remainder <sup>4</sup>	19.0-23.0	15.0-17.0	5.0 max	3.0-4.4	0.010 max	0.08	...	0.75 max	...	0.04	0.02	0.02-0.25	...	...	...	...	...	...	...	...	...	...	...
Ni-Co-Cr-Si Alloy N12160	remainder <sup>4</sup>	26.0-30.0	1.0 max	3.5 max	1.0 max	0.15 max	2.4-3.0	27.0-33.0	1.5 max	...	0.030	0.015	0.20-0.80	...	...	...	...	...	...	...	1.0 max	...	...	...
Cr-Ni-Fe-N Alloy R20033	30.0-33.0	31.0-35.0	0.50-2.0	balance	...	0.015 max	0.50†	...	2.0 max	...	0.02	0.01	...	0.3-1.20	...	...	...	...	0.35-0.60	...	...	...	...	...
Low C-Ni-Mo-Cr-Ta Alloy N06210	remainder <sup>4</sup>	18.0-20.0	18.0-20.0	1.0 max	...	0.015 max	0.08	1.0 max	0.5	0.35 max	0.02	0.02	...	...	...	...	...	...	...	...	...	1.5-2.2	...	...

<sup>4</sup> The composition of the remainder shall be determined arithmetically by difference.

ASME NORMDOC.COM Click to view the full PDF of ASME BPVC.II.B (ASME BPVC Section II part B) 2025

TABLE 2 Dimensions of Welded Pipe

NOTE 1—The following table is a partial reprint of Table 1 of ANSI B36.19.

NOTE 2—The decimal thickness listed for the respective pipe sizes represents their nominal or average wall dimensions.

Nominal Pipe Size,	Outside Diameter		Nominal Wall Thickness							
			Schedule 5S <sup>A</sup>		Schedule 10S <sup>A</sup>		Schedule 40S		Schedule 80S	
			in.	[mm]	in.	[mm]	in.	[mm]	in.	[mm]
1/8	0.405	10.29	...	...	0.049	1.24	0.068	1.73		
1/4	0.540	13.72	...	...	0.065	1.65	0.088	2.24		
3/8	0.675	17.15	...	...	0.065	1.65	0.091	2.31		
1/2	0.840	21.34	0.065	1.65	0.083	2.11	0.109	2.77		
3/4	1.050	26.67	0.065	1.65	0.083	2.11	0.113	2.87		
1.0	1.315	33.41	0.065	1.65	0.109	2.77	0.133	3.38		
1 1/4	1.660	42.16	0.065	1.65	0.109	2.77	0.140	3.56		
1 1/2	1.900	48.26	0.065	1.65	0.109	2.77	0.145	3.68		
2	2.375	60.33	0.065	1.65	0.109	2.77	0.154	3.91	0.218	5.54
2 1/2	2.875	73.03	0.083	2.11	0.120	3.05	0.203	5.16	0.276	7.01
3	3.500	88.90	0.083	2.11	0.120	3.05	0.216	5.33		
3 1/2	4.000	101.60	0.083	2.11	0.120	3.05	0.226	5.74		
4	4.500	114.30	0.083	2.11	0.120	3.05	0.237	6.02		
5	5.563	141.30	0.109	2.77	0.134	3.40	0.258	6.55		
6	6.625	168.28	0.109	2.77	0.134	3.40	0.280	7.11		
8	8.625	219.18	0.109	2.77	0.148	3.76	0.322	8.18		

<sup>A</sup> Schedules 5S and 10S wall thicknesses do not permit threading in accordance with ANSI B2.1-1960.

specification. Examples of such requirements include, but are not limited to the following:

- 5.1.1 *Alloy* (Table 1),
- 5.1.2 *Class* (see 1.3),
- 5.1.3 *Quantity* (feet or number of lengths),
- 5.1.4 *Size* (nominal size or outside diameter and schedule number or average wall thickness),
- 5.1.5 *Length*—Specify cut length or random,
- 5.1.6 *Certification*—Certification and a report of test results is required (SB-775),
- 5.1.7 *Purchaser Inspection*—State which tests or inspections are to be witnessed,
- 5.1.8 *Ends*—Plain ends cut and deburred will be furnished, unless otherwise specified, and
- 5.1.9 *Samples for Product (Check) Analysis*—State whether samples shall be furnished.

## 6. Materials and Manufacture

6.1 The pipe shall be made from flat-rolled alloy by an automatic welding process with no addition of filler metal.

6.2 Subsequent to welding and prior to final heat treatment, Class II pipes shall be cold worked either in both weld and base metal or in weld metal only. The method of cold working may be specified by the purchaser.

## 7. Chemical Composition

7.1 The material shall conform to the composition limits specified in Table 1.

7.2 If a product (check) analysis is made by the purchaser, the material shall conform to the requirements specified in Table 1 subject to the permissible tolerances in Specification B775.

## 8. Mechanical Properties and Other Requirements

8.1 *Tension Test*—The tensile properties of the material at room temperature shall conform to those shown in Table 3.

8.1.1 One tension test shall be made on each lot of pipe.

8.2 *Flattening Test*—One flattening test shall be made on a specimen from one end of one pipe from each lot.

### 8.3 Transverse Guided Bend Test:

8.3.1 At the option of the pipe manufacturer, the transverse guided bend test may be substituted in lieu of the flattening test. Two bend specimens shall be taken transversely from pipe or the test specimens may be taken from a test plate of the same material and heat as pipe, which is attached to the end of the cylinder and welded as a prolongation of the pipe longitudinal seam. Except as provided in 8.3.2, one shall be subjected to a face guided bend and a second to a root guided bend test. One specimen shall be bent with the inside surface of the pipe against the plunger and the other with the outside surface of the pipe against the plunger. Guided bend test specimens shall be prepared and tested in accordance with Section IX, Part QW 160 of the ASME Boiler and Pressure Vessel Code and shall be one of the types shown in QW462.2 and QW462.3 of that code.

8.3.2 For specified wall thicknesses 3/8 in. [9.5 mm] and over, but less than 3/4 in. [19 mm] side bend tests may be made instead of the face and root bend tests. For specified wall thicknesses 3/4 in. [19 mm] and over, both specimens shall be subjected to the side bend tests. Side bend specimens shall be bent so that one of the side surfaces becomes the convex surface of the bend specimen.

8.3.3 The bend test shall be acceptable if no cracks or other defects exceeding 1/8 in. [3 mm] in any direction be present in the weld metal or between the weld and the pipe or plate metal after bending. Cracks which originate along the edges of the specimen during testing, and are less than 1/4 in. [6.5 mm] measured in any direction shall not be considered.

8.4 *Hydrostatic or Nondestructive Electric Test*—Each pipe shall be subjected to either the hydrostatic or the nondestructive electric test at the manufacturer's option.

TABLE 3 Mechanical Properties of Pipe

Alloy	Tensile Strength, min, ksi [MPa]	Yield Strength (0.2 % Offset), min, ksi [MPa]	Elongation in 2 in. [50.8 mm] or 4D, <sup>A</sup> min, %
<b>Ni-Mo Alloys</b>			
alloy N10001	100 [690]	45 [310]	40
alloy N10665	110 [760]	51 [350]	40
alloy N10675	110 [760]	51 [350]	40
alloy N10629	110 [760]	51 [350]	40
alloy N10624	104 [720]	46 [320]	40
<b>Ni-Mo-Cr-Fe Alloy</b>			
alloy N10242	105 [725]	45 [310]	40
<b>Low C Ni-Cr-Mo Alloys</b>			
alloy N10276	100 [690]	41 [283]	40
alloy N06022	100 [690]	45 [310]	45
alloy N06035	85 [586]	35 [241]	30
alloy N06044	90 [620]	45 [310]	20
alloy N06455	100 [690]	40 [276]	40
<b>Ni-Cr-Fe-Mo-Cu Alloys</b>			
alloy N06007	90 [621]	35 [241]	35
alloy N06975	85 [586]	32 [221]	40
alloy N06985	90 [621]	35 [241]	45
alloy N06030	85 [586]	35 [241]	30
Ni-Fe-Cr-Mo Alloy (N08320)	75 [517]	28 [193]	35
Ni-Cr-Mo-Fe Alloy (N06002)	100 [690]	40 [276]	35
Ni-Fe-Cr-Co Alloy (R30556)	100 [690]	45 [310]	40
Ni-Cr-W-Mo Alloy (N06230) <sup>B</sup>	110 [760]	45 [310]	40
<b>Low C-Ni-Cr-Mo Alloys</b>			
alloy N06058	110 [760]	52 [360]	40
alloy N06059	100 [690]	45 [310]	45
Low C-Ni-Cr-Mo-Cu Alloy (N06200)	100 [690]	45 [310]	45
Low C-Ni-Mo-Cr Alloy (N10362)	105 [725]	45 [310]	40
Ni-Fe-Cr-Mo-Cu Low Carbon Alloy (N08031)	94 [650]	40 [276]	40
Low C Ni-Cr-Mo-W Alloy (N06686)	100 [690]	45 [310]	45
Ni-Co-Cr-Si alloy (N12160)	90 [620]	35 [240]	40
Cr-Ni-Fe-N Low Carbon Alloy (R20033)	109 [750]	55 [380]	40
Low C Ni-Cr-Mo-Ta Alloy (N06210)	100 [690]	45 [310]	45

<sup>A</sup> D refers to the diameter of the tension specimen.

<sup>B</sup> Solution annealed at a temperature between 2200 to 2275°F [1204 to 1246°C] followed by a water quench or rapidly cooled by other means.

9. Dimensions and Permissible Variations

9.1 Wall Thickness—Variations in wall thickness shall not exceed the specified nominal wall thickness by more than ±12½ %, except as follows:

9.1.1 If weld beads are present on the inner surface of the pipe, they shall not exceed the wall thickness of the pipe by more than 20 % or 0.050 in. [1.27 mm], whichever is less, of the specified nominal wall thickness for Class I pipe, and 5 % or 0.005 in. [0.127 mm], whichever is less, of the specified nominal wall thickness for Class II pipe.

TABLE 4 Permissible Variations in Outside Diameter

Nominal Pipe Size, in.	Permissible Variation in Outside Diameter <sup>A</sup>			
	in.		mm	
¼ [10.29]	+0.002	-0.006	+0.05	-0.15
¼ [13.72]	+0.003	-0.008	+0.08	-0.20
⅜ [17.15]	+0.004	-0.008	+0.08	-0.20
½ [21.34]	+0.004	-0.010	+0.10	-0.25
¾ [26.67]	+0.005	-0.012	+0.13	-0.30
1 [33.41]	+0.005	-0.012	+0.13	-0.30
1¼ [42.16]	+0.005	-0.012	+0.13	-0.30
1½ [48.26]	+0.008	-0.015	+0.20	-0.38
2 [60.22]	+0.010	-0.016	+0.25	-0.41
2½ [73.03]	+0.010	-0.016	+0.25	-0.41
3 [88.90]	+0.012	-0.018	+0.30	-0.46
3½ [101.60]	+0.012	-0.018	+0.30	-0.46
4 [114.30]	+0.014	-0.020	+0.36	-0.51
5 [141.30]	+0.063	0.031	+1.60	-0.79
6 [168.28]	+0.063	0.031	+1.60	-0.79
8 [219.18]	+0.063	0.031	+1.60	-0.79

<sup>A</sup> The permissible variations in the above table apply to individual measurements, including out of roundness (ovality).

9.1.2 Sunken welds in Class I pipe shall not be deeper than 15 % of the specified nominal wall thickness and never deeper than 0.030 in. [0.79 mm]. Class II pipe shall not have sunken welds.

9.2 Outside Diameter—The permissible variations in outside diameter shall not exceed the limits prescribed in Table 4, except as provided for in 9.1.2.

9.3 For pipe diameters greater than shown in Table 4, permissible variations in dimensions at any point in a length of pipe shall not exceed the following:

9.3.1 Outside Diameter—Based on circumferential measurement, ±0.5 % of the nominal outside diameter.

9.3.2 Out-of-Roundness—Differences between major and minor outside diameters, 1.0 % of the specified outside diameter.

9.3.2.1 For thin-wall pipe, defined as pipe having a wall thickness of 3 % or less of the outside diameter, the difference in the extreme outside readings (ovality) in any one cross section shall not exceed 1.5 % of the specified outside diameter.

9.3.3 Alignment (Camber)—Using a 10 ft. [3 m] straight-edge placed so that both ends are in contact with the pipe, the camber shall not be more than ¼ in. [3.17 mm].

10. Keywords

10.1 UNS N06002; UNS N06007; UNS N06022; UNS N06030; UNS N06035; UNS N06044; UNS N06058; UNS N06059; UNS N06200; UNS N10362; UNS N06210; UNS N06230; UNS N06455; UNS N06975; UNS N06985; UNS N08031; UNS N08320; UNS N10001; UNS N10242; UNS N10276; UNS N10624; UNS N10629; UNS N10665; UNS N10675; UNS R30556; welded pipe

**APPENDIX****(Nonmandatory Information)****X1. HEAT TREATMENT**

X1.1 Proper heat treatment during or subsequent to fabrication is necessary for optimum performance, and the manufacturer shall be consulted for details.

ASMENORMDOC.COM : Click to view the full PDF of ASME BPVC.II.B (ASME BPVC Section II part B) 2025

ASMENORMDOC.COM : Click to view the full PDF of ASME BPVC.II.B (ASME BPVC Section II part B) 2025

INTENTIONALLY LEFT BLANK



# Standard Specification for Nickel-Iron-Chromium-Molybdenum Alloy (UNS N08320) Plate, Sheet, and Strip

## 1. Scope

1.1 This specification covers rolled nickel-iron-chromium-molybdenum alloy (UNS N08320) plate, sheet, and strip, for use in general corrosive service.

1.2 The following products are covered under this specification:

1.2.1 *Sheet and Strip*—Hot or cold rolled, solution annealed, and descaled unless solution anneal is performed in an atmosphere yielding a bright finish.

1.2.2 *Plate*—Hot rolled, solution annealed, and descaled.

1.3 The values stated in inch-pound units are to be regarded as standard. The values given in parentheses are mathematical conversions to SI units that are provided for information only and are not considered standard.

1.4 *This standard does not purport to address all of the safety concerns, if any, associated with its use. It is the responsibility of the user of this standard to become familiar with all hazards including those identified in the appropriate Material Safety Data Sheet (MSDS) for this product/material as provided by the manufacturer, to establish appropriate safety and health practices, and determine the applicability of regulatory limitations prior to use.*

## 2. Referenced Documents

### 2.1 ASTM Standards:

B906 Specification for General Requirements for Flat-Rolled Nickel and Nickel Alloys Plate, Sheet, and Strip  
E140 Hardness Conversion Tables for Metals Relationship Among Brinell Hardness, Vickers Hardness, Rockwell Hardness, Superficial Hardness, Knoop Hardness, and Scleroscope Hardness

## 3. Terminology

### 3.1 Definitions of Terms Specific to This Standard:

3.1.1 *plate, n*—material  $\frac{3}{16}$  in. (4.76 mm) and over in thickness.

3.1.2 *sheet and strip, n*—material under  $\frac{3}{16}$  in. (4.76 mm) in thickness.

## 4. General Requirements

4.1 Material furnished under this specification shall conform to the applicable requirements of Specification B906 unless otherwise provided herein.

## 5. Ordering Information

5.1 It is the responsibility of the purchaser to specify all requirements that are necessary for the safe and satisfactory performance of material ordered under this specification. Examples of such requirements include, but are not limited to, the following:

5.1.1 *Dimensions*—Thickness (in decimals of an inch), width, and length (inch or fraction of an inch).

5.1.2 *Certification*—Certification and a report of test results are required (Specification B906, Section 21).

### 5.1.3 *Optional Requirement:*

5.1.3.1 *Plate*—State how plate is to be cut (Specification B906, Table A2.3).

5.1.4 *Purchase Inspection*—State which tests or inspections are to be witnessed (Specification B906, Section 18).

5.1.5 *Samples for Product (Check) Analysis*—State whether samples should be furnished (Specification B906, Section 7.2.2).

## 6. Chemical Composition

6.1 The material shall conform to the composition limits specified in Table 1.

6.2 If a product (check) analysis is made by the purchaser, the material shall conform to the requirements specified in Table 1 and Specification B906.

TABLE 1 Chemical Requirements

Element	Composition Limits, %
Nickel	25.0–27.0
Iron	remainder <sup>A</sup>
Chromium	21.0–23.0
Molybdenum	4.0–6.0
Manganese, max	2.5
Carbon, max	0.05
Titanium, min	4 × carbon
Silicon, max	1.00
Phosphorus, max	0.04
Sulfur, max	0.03

<sup>A</sup> See Specification B906.

## 7. Mechanical Properties and Other Requirements

7.1 *Tensile Properties*—The material shall conform to the room temperature tensile properties prescribed in Table 2.

7.2 *Hardness*—The hardness values given in Table 2 are informative only.

## 8. Dimensions, Mass, and Permissible Variations

8.1 *Weight*—The material covered by this specification shall be assumed to weigh 0.291 lb/in.<sup>3</sup> (8.05 g/cm<sup>3</sup>).

8.2 *Thickness*:

8.2.1 *Sheet and Strip*—The thickness shall be measured with the micrometer spindle  $\frac{3}{8}$  in. (9.525 mm) or more from any edge for material 1 in. (25.4 mm) or over in width and at any place on material under 1 in. in width.

TABLE 2 Mechanical Property Requirements

Tensile Strength min, psi (MPa)	Yield Strength (0.2 % Offset) min, psi (MPa)	Elongation in 2 in. (50.8 mm) or 4D <sup>A</sup> min, %	Rockwell Hardness, <sup>B</sup> max
75 000 (517)	28 000 (193)	35	95 HRB

<sup>A</sup> D refers to the diameter of the tension specimen.

<sup>B</sup> Hardness values are shown for information purposes only and are not to be used as a basis for rejection or acceptance. For approximate hardness conversions, see Hardness Conversion Tables E140.

8.3 *Length*:

8.3.1 *Sheet and Strip*: Sheet and strip may be ordered to cut lengths, in which case a variation of  $\frac{1}{8}$  in. (3.175 mm) over the specified length shall be permitted with a zero minus tolerance.

8.4 *Straightness*:

8.4.1 The edgewise curvature (depth of cord) of flat sheet, strip, and plate shall not exceed 0.05 in. multiplied by the length in feet or 0.04 mm multiplied by the length in centimeters.

8.4.2 Straightness for coiled strip is subject to agreement between the manufacturer and the purchaser.

8.5 *Squareness* (Sheet)—For sheets of all thicknesses and widths of 6 in. (152.4 mm) or more, the angle between adjacent sides shall be  $90 \pm 0.15$  deg ( $\frac{1}{16}$  in./24 in. or 2.6 mm/m).

8.6 *Flatness*—Plate, sheet, and strip shall be commercially flat.

8.7 *Edges*:

8.7.1 Plate shall have sheared or abrasive cut or plasma-torch-cut edges as specified.

8.7.2 Sheet and strip shall have sheared or slit edges.

## 9. Certification

9.1 A manufacturer's certification shall be furnished to the purchaser stating that the material has been manufactured, tested, and inspected in accordance with this specification, and that the test results on representative samples meet specification requirements. A report of the test results shall be furnished.

## 10. Product Marking

10.1 Each plate, sheet, or strip shall be marked on one face with the specification number, alloy, heat number, manufacturer's identification, and size. The markings shall have no deleterious effect on the material or its performance and shall be sufficiently stable to withstand normal handling.

10.2 Each bundle or shipping container shall be marked with the name of the material; this specification number; alloy; the size; gross, tare, and net weight; consignor and consignee address; contract or order number; and such other information as may be defined in the contract or order.

## 11. Keywords

11.1 plate; sheet; strip; N08320

## APPENDIX

### (Nonmandatory Information)

#### X1. HEAT TREATMENT

X1.1 Proper heat treatment during or subsequent to fabrication is necessary for optimum performance, and the manufacturer shall be consulted for details.

ASMENORMDOC.COM : Click to view the full PDF of ASME BPVC.II.B (ASME BPVC Section II part B) 2025

INTENTIONALLY LEFT BLANK

# SPECIFICATION FOR NICKEL-IRON- CHROMIUM-MOLYBDENUM ALLOY (UNS N08320) ROD



SB-621

(Identical with ASTM Specification B621-02(2011) except that certification and test reports have been made mandatory.)

# Standard Specification for Nickel-Iron-Chromium-Molybdenum Alloy (UNS N08320) Rod

## 1. Scope

1.1 This specification covers nickel-iron chromium-molybdenum alloy (UNS N08320) rod for use in general corrosive service.

1.2 The following products are covered under this specification:

1.2.1 Rods  $\frac{5}{16}$  to  $\frac{3}{4}$  in. (7.94 to 19.05 mm) excl in diameter, hot or cold finished, solution annealed and pickled or mechanically descaled.

1.2.2 Rods  $\frac{3}{4}$  to  $3\frac{1}{2}$  in. (19.05 to 88.9 mm) incl in diameter, hot or cold finished, solution annealed, ground or turned.

1.3 The values stated in inch-pound units are to be regarded as the standard. The values given in parentheses are for information only.

1.4 *This standard does not purport to address all of the safety concerns, if any, associated with its use. It is the responsibility of the user of this standard to become familiar with all hazards including those identified in the appropriate Material Safety Data Sheet (MSDS) for this product/material as provided by the manufacturer, to establish appropriate safety and health practices, and determine the applicability of regulatory limitations prior to use.*

## 2. Referenced Documents

### 2.1 ASTM Standards:

B880 Specification for General Requirements for Chemical Check Analysis Limits for Nickel, Nickel Alloys and Cobalt Alloys

E8 Test Methods for Tension Testing of Metallic Materials

E29 Practice for Using Significant Digits in Test Data to Determine Conformance with Specifications

E527 Practice for Numbering Metals and Alloys in the Unified Numbering System (UNS)

E1473 Test Methods for Chemical Analysis of Nickel, Cobalt, and High-Temperature Alloys

## 3. Terminology

### 3.1 Definitions of Terms Specific to This Standard:

3.1.1 *rod, n*—a product of round solid section furnished in straight lengths.

## 4. Ordering Information

4.1 It is the responsibility of the purchaser to specify all requirements that are necessary for material ordered under this specification. Examples of such requirements include but are not limited to the following:

4.1.1 *Dimensions*—Nominal diameter and length. The shortest useable multiple length shall be specified (Table 1).

4.1.2 DELETED

4.1.3 *Purchaser Inspection*—State which tests or inspections are to be witnessed (Section 13).

4.1.4 *Samples for Product (Check) Analysis*—State whether samples shall be furnished (9.2.2).

## 5. Chemical Composition

5.1 The material shall conform to the composition limits specified in Table 2.

5.2 If a product (check) analysis is made by the purchaser, the material shall conform to the requirements specified in Table 2 subject to the permissible tolerances in Specification B880.

## 6. Mechanical Properties and Other Requirements

6.1 The mechanical properties of the material at room temperature shall conform to those shown in Table 3.

## 7. Dimensions, Mass and Permissible Variations

7.1 *Diameter*—The permissible variations from the specified diameter shall be as prescribed in Table 4.

**TABLE 1 Permissible Variations in Length of Rods**

Random mill lengths	2 to 12 ft (610 to 3660 mm) long with not more than 25 weight % under 4 ft (1.22 m).
Multiple lengths	Furnished in multiples of a specified unit length, within the length limits indicated above. For each multiple, an allowance of $\frac{1}{4}$ in. (6.35 mm) shall be made for cutting, unless otherwise specified. At the manufacturer's option, individual specified unit lengths may be furnished.
Nominal lengths	Specified nominal lengths having a range of not less than 2 ft (610 mm) with no short lengths allowed.
Cut lengths	A specified length to which all rods shall be cut with a permissible variation of $+\frac{1}{8}$ in. (3.17 mm) - 0.

**TABLE 2 Chemical Requirements**

Element	Composition Limits, %
Nickel	25.0–27.0
Iron	remainder <sup>A</sup>
Chromium	21.0–23.0
Molybdenum	4.0–6.0
Manganese, max	2.5
Carbon, max	0.05
Titanium, min	4 × carbon
Silicon, max	1.00
Phosphorus, max	0.04
Sulfur, max	0.03

<sup>A</sup> See 12.1.1.**TABLE 3 Mechanical Property Requirements**

Tensile Strength, min, psi (MPa)	Yield Strength (0.2 % Offset), min, psi (MPa)	Elongation in 2 in. (50.8) or 4D <sup>A</sup> , min, %
75 000 (517)	28 000 (193)	35

<sup>A</sup> D refers to the diameter of the tension specimen.

7.2 *Out of Roundness*—The permissible variation in roundness shall be as prescribed in Table 4.

7.3 *Matching Allowances*—When the surfaces of finished material are to be machined, the following allowances are suggested for normal machining operations:

7.3.1 *As-finished (Annealed and Descaled)*—For diameters of  $\frac{5}{16}$  to  $\frac{11}{16}$  in. (7.94 to 17.46 mm) incl, an allowance of  $\frac{1}{16}$  in. (1.59 mm) on the diameter should be made for finish machining.

7.4 *Length*:

7.4.1 Unless multiple, nominal, or cut lengths are specified, random mill lengths shall be furnished.

7.4.2 The permissible variations in length of multiple, nominal, or cut length rod shall be as prescribed in Table 1. Where rods are ordered in multiple lengths, an additional  $\frac{1}{4}$  in. (6.35 mm) in length shall be allowed for each uncut multiple length.

7.5 *Ends*:

7.5.1 Rods ordered to random or nominal lengths shall be furnished with either cropped or sawed ends.

7.5.2 Rods ordered to cut lengths shall be furnished with square saw cut or machined ends.

7.6 *Weight*—The material covered by this specification shall be assumed to weigh 0.291 lb/in.<sup>3</sup> (8.05 g/cm<sup>3</sup>).

7.7 *Straightness*—The maximum curvature (depth of cord) shall not exceed 0.050 in. multiplied by the length of the cord in feet (0.04 mm multiplied by the length in centimetres).

## 8. Workmanship, Finish, and Appearance

8.1 The material shall be uniform in quality and condition, smooth, and free of injurious imperfections.

## 9. Sampling

9.1 *Lots for Chemical Analysis and Mechanical Testing*:

9.1.1 A lot for chemical analysis shall consist of one heat.

9.1.2 A lot of bar for mechanical testing shall be defined as the material from one heat in the same condition and specified diameter.

9.2 *Sampling for Chemical Analysis*:

9.2.1 A representative sample shall be obtained from each heat during pouring or subsequent processing.

9.2.2 Product (check) analysis shall be wholly the responsibility of the purchaser.

9.3 *Sampling for Mechanical Testing*:

9.3.1 A representative sample shall be taken from each lot of finished material.

## 10. Number of Tests and Retests

10.1 *Chemical Analysis*—One test per heat.

10.2 *Tension Tests*—One test per lot.

10.3 *Retests*—If the specimen used in the mechanical test of any lot fails to meet the specified requirements, two additional specimens shall be taken from different sample pieces and tested. The results of the tests on both of these specimens shall meet the specified requirements.

## 11. Specimen Preparation

11.1 Tension test specimens shall be taken from material after final heat-treatment and tested in the direction of fabrication.

11.2 Tension test specimens shall be any of the standard or subsized specimens shown in Test Methods E8.

11.3 In the event of a disagreement, the referee specimen shall be the largest possible round specimen shown in Test Methods E8.

## 12. Test Methods

12.1 The chemical composition and mechanical properties of the material as enumerated in this specification shall be determined, in case of disagreement, in accordance with the following ASTM methods:

12.1.1 *Chemical Analysis*—Test Methods E1473.

12.1.2 *Tension Test*—Test Methods E8.

12.1.3 *Determining Significant Places*—Practice E29.

12.2 For purposes of determining compliance with the limits in this specification, an observed value or a calculated value shall be rounded in accordance with the rounding method of Practice E29:

**TABLE 4 Permissible Variations in Diameter and Out-of-Roundness of Finished Rods**

Specified Diameter, in. (mm)	Permissible Variations, in. (mm)		
	Diameter		Out of Roundness, max
	Plus	Minus	
Hot-Finished, Annealed, and Descaled Rods			
5/16 to 7/16 (7.94–11.11), incl	0.012 (0.30)	0.012 (0.30)	0.018 (0.46)
Over 7/16 to 5/8 (11.11–15.87), incl	0.014 (0.36)	0.014 (0.36)	0.020 (0.51)
Over 5/8 to 3/4 (15.87–19.05), excl	0.016 (0.41)	0.016 (0.41)	0.024 (0.61)
Hot-Finished, Annealed, and Ground or Turned Rods			
3/4 to 3 1/2 (19.05–88.9), incl	0.010 (0.25)	0	0.008 (0.20)

Requirements	Rounded Unit for Observed or Calculated Value
Chemical composition and tolerance	nearest unit in the last right-hand place of figures of the specified limit
Tensile strength and yield strength	nearest 1000 psi (7 MPa)
Elongation	nearest 1 %

**13. Inspection**

13.1 Inspection of the material shall be made as agreed upon by the manufacturer and the purchaser as part of the purchase contract.

**14. Rejection and Rehearing**

14.1 Material tested by the purchaser that fails to conform to the requirements of this specification may be rejected. Rejection should be reported to the producer or supplier promptly and in writing. In case of dissatisfaction with the results of the test, the producer or supplier may make claim for a rehearing.

**15. Certification**

15.1 A manufacturer’s certification shall be furnished to the

purchaser stating that material has been manufactured, tested, and inspected in accordance with this specification, and that the test results on representative samples meet specification requirements. A report of the test results shall be furnished.

**16. Product Marking**

16.1 Each piece of material 1/2 in. (12.7 mm) or over in diameter shall be marked with the specification number, alloy, heat number, manufacturer’s identification, and size. The markings shall have no deleterious effect on the material or its performance and shall be sufficiently stable to withstand normal handling.

16.2 Each bundle or shipping container shall be marked with the name of the material; this specification number; alloy; the size; gross, tare, and net weight; consignor and consignee address; contract or order number; and such other information as may be defined in the contract or order.

**17. Keywords**

17.1 rod; UNS N08320

**APPENDIX**

(Nonmandatory Information)

**X1. HEAT TREATMENT**

X1.1 Proper heat treatment during or subsequent to fabrication is necessary for optimum performance, and the manu-

facturer shall be consulted for details.

# SPECIFICATION FOR SEAMLESS NICKEL AND NICKEL-COBALT ALLOY PIPE AND TUBE



**SB-622**

(Identical with ASTM Specification B622-17b except that certification and test reports have been made mandatory and "Remainder" element defined in Table 1.)

# Specification for Seamless Nickel and Nickel-Cobalt Alloy Pipe and Tube

## 1. Scope

1.1 This specification covers seamless pipe and tube of nickel and nickel-cobalt alloys (UNS N10001, UNS N10242, UNS N10665, UNS N12160, UNS N10675, UNS N10276, UNS N06455, UNS N06007, UNS N08320, UNS N06975, UNS N06002, UNS N06985, UNS N06022, UNS N06035, UNS N06044, UNS N08135, UNS N06255, UNS N06058, UNS N06059, UNS N06200, UNS N10362, UNS N06030, UNS N08031, UNS N08034, UNS R30556, UNS N08535, UNS N06250, UNS N06060, UNS N06230, UNS N06686, UNS N10629, UNS N06210, UNS N10624, and UNS R20033) as shown in Table 1.

1.2 Pipe and tube shall be supplied in the solution annealed and descaled condition. When atmosphere control is used, descaling is not necessary.

1.3 This specification is limited to tubes up to and including 3.5 in. (88.9 mm) outside diameter.

1.4 The values stated in inch-pound units are to be regarded as standard. The values given in parentheses are mathematical conversions to SI units that are provided for information only and are not considered standard.

1.5 *This standard does not purport to address all of the safety concerns, if any, associated with its use. It is the responsibility of the user of this standard to become familiar with all hazards including those identified in the appropriate Safety Data Sheet (SDS) for this product/material as provided by the manufacturer, to establish appropriate safety, health, and environmental practices, and determine the applicability of regulatory limitations prior to use.*

1.6 *This international standard was developed in accordance with internationally recognized principles on standardization established in the Decision on Principles for the Development of International Standards, Guides and Recommendations issued by the World Trade Organization Technical Barriers to Trade (TBT) Committee.*

## 2. Referenced Documents

### 2.1 ASTM Standards:

B829 Specification for General Requirements for Nickel and Nickel Alloys Seamless Pipe and Tube  
E8 Test Methods for Tension Testing of Metallic Materials  
E527 Practice for Numbering Metals and Alloys in the Unified Numbering System (UNS)

## 3. Terminology

### 3.1 Definitions:

3.1.1 *average diameter, n*—the average of the maximum and minimum outside diameters, or the maximum and minimum inside diameters, as determined at any cross section of the tube.

3.1.2 *pipe, n*—seamless tube conforming to the particular dimensions commercially known as standard pipe sizes (Appendix X2).

3.1.3 *tube, n*—a hollow product of round or any other cross section having a continuous periphery.

## 4. General Requirements

4.1 Material furnished under this specification shall conform to the applicable requirements of Specification B829 unless otherwise provided herein.

## 5. Ordering Information

5.1 It is the responsibility of the purchaser to specify all requirements that are necessary for the material ordered under this specification. Examples of such requirements include, but are not limited to the following:

5.1.1 *Alloy* (Table 1).

5.1.2 *Dimensions*:

5.1.2.1 *Tube*—Outside diameter, minimum or average wall thickness, and length.

5.1.2.2 *Pipe*—Standard pipe size and schedule (Appendix X2).

TABLE 1 Chemical Requirements

		Composition Limits, %																						
	Ni	Cr	Mo	Fe	W	C	Si max	Co	Mn	V	P max	S max	Ti	Cu	Cb (Nb) +Ta	Al	Zr	La	N	B	Cb (Nb)	Ta	Ni+ Mo	Mg
Ni-Mo Alloys																								
N10001	remainder A	1.0 max	26.0- 30.0	4.0-6.0	...	0.05 max	1.0	2.5 max	1.0 max	0.2- 0.4	0.04	0.03	...	...	...									
N10665	remainder A	1.0 max	26.0- 30.0	2.0 max	...	0.02 max	0.10	1.0 max	1.0 max	...	0.04	0.03	...	...	...									
N10675	65.0 min	1.0- 3.0	27.0- 32.0	1.0-3.0	3.0 max	0.01 max	0.10	3.0 max	3.0 max	0.20 max	0.030	0.010	0.20 max	0.20 max	...	0.50 max	0.10 max	...	...	...	0.20 max	0.20 max	94.0- 98.0	
N10629	remainder A	0.5- 1.5	26.0- 30.0	1.0-6.0	...	0.01 max	0.05	2.5 max	1.5 max	...	0.04	0.01	...	0.5 max	...	0.1- 0.5	...	...	...	...	...	...	...	...
N10624	remainder A	6.0- 10.0	21.0- 25.0	5.0-8.0	...	0.01 max	0.10	1.0 max	1.0 max	...	0.025	0.01	...	0.5 max	...	...	...	...	...	...	...	...	...	...
Ni-Mo-Cr-Fe Alloy																								
N10242	remainder A	7.0- 9.0	24.0- 26.0	2.0 max		0.03 max	0.80	1.00 max	0.80 max		0.030	0.015		0.50 max		0.50 max					0.006 max			
Low C Ni-Cr-Mo Alloys																								
N10276	remainder A	14.5- 16.5	15.0- 17.0	4.0-7.0	3.0- 4.5	0.010 max	0.08	2.5 max	1.0 max	0.35 max	0.04	0.03	...	...	...									
N06022	remainder A	20.0- 22.5	12.5- 14.5	2.0-6.0	2.5- 3.5	0.015 max	0.08	2.5 max	0.50 max	0.35 max	0.02	0.02	...	...	...									
N06035	remainder A	32.25- 34.25	7.60- 9.00	2.00 max	0.60 max	0.050 max	0.60	1.00 max	0.50 max	0.20 max	0.030	0.015	...	0.30 max	...	0.40 max	...	...	...	...	...	...	...	...
N06044	balance	43.5- 45.3	0.80- 1.20	0.3 max	...	0.02 max	0.20	...	0.07- 0.30	...	0.020	0.020	0.10- 0.30	...	...	0.30 max	...	...	...	...	...	...	...	...
N06058	balance	20.0- 23.0	18.5- 21.0	1.5 max	0.3 max	0.010 max	0.10	0.3 max	0.50 max	...	0.015	0.010	...	0.50 max	...	0.40 max	...	...	0.02- 0.15	...	...	...	...	...
N06059	balance	22.0- 24.0	15.0- 16.5	1.5 max	...	0.010 max	0.10	0.3 max	0.5 max	...	0.015	0.010	...	0.50 max	...	0.1- 0.4	...	...	...	...	...	...	...	...
N06455	remainder A	14.0- 18.0	14.0- 17.0	3.0 max	...	0.015 max	0.08	2.0 max	1.0 max	...	0.04	0.03	0.70 max	...	...									
Ni-Cr-Fe-Mo-Cu Alloys																								
N06007	remainder A	21.0- 23.5	5.5- 7.5	18.0-21.0	1.0 max	0.05 max	1.0	2.5 max	1.0- 2.0	...	0.04	0.03	...	1.5- 2.5	1.75- 2.5									
N06975	47.0-52.0	23.0- 26.0	5.0- 7.0	remainder A	...	0.03 max	1.0	...	1.0 max	...	0.03	0.03	0.70- 1.50	0.70- 1.20	...									
N06985	remainder A	21.0- 23.5	6.0- 8.0	18.0-21.0	1.5 max	0.015 max	1.0	5.0 max	1.0 max	...	0.04	0.03	...	1.5- 2.5	0.50 max									
N06030	remainder A	28.0- 31.5	4.0- 6.0	13.0-17.0	1.5- 4.0	0.03 max	0.8	5.0 max	1.5 max	...	0.04	0.02	...	1.0- 2.4	0.30- 1.50									
N06255	47.0-52.0	23.0- 26.0	6.0- 9.0	remainder A	3.0 max	0.03 max	1.0	...	1.0 max	...	0.03	0.03	0.69 max	1.2 max	...									
N06250	50.0-54.0	20.0- 23.0	10.1- 12.0	remainder A	0.25- 1.25	0.020 max	0.09	...	1.00 max	...	0.030	0.005	...	0.25- 1.25	...									
Ni-Fe-Cr-Mo Alloys																								
N08320	25.0-27.0	21.0- 23.0	4.0- 6.0	remainder A	...	0.05 max	1.0	...	2.5 max	...	0.04	0.03	4xC min	...	...									
N08135	33.0-38.0	20.5- 23.5	4.0- 5.0	remainder A	0.20- 0.80	0.030 max	0.75	...	1.00 max	...	0.03	0.03	...	...	...									
N06002	remainder A	20.5- 23.0	8.0- 10.0	17.0-20.0	0.20- 1.0	0.05- 0.15	1.0	0.5- 2.5	1.0 max	...	0.04	0.03	...	...	...									

TABLE 1 Continued

Composition Limits, %

	Ni	Cr	Mo	Fe	W	C	Si max	Co	Mn	V	P max	S max	Ti	Cu	Cb (Nb) +Ta	Al	Zr	La	N	B	Cb (Nb)	Ta	Ni+ Mo	Mg	
N06060	54.0–60.0	19.0- 22.0	12.0- 14.0	remainder A	0.25- 1.25	0.03 max	0.50	...	1.50 max	...	0.030 max	0.005 max	...	0.25- 1.25	0.50- 1.25										
Ni-Fe-Cr-Co Alloy R30556	19.0-22.5	21.0- 23.0	2.5- 4.0	remainder A	2.0- 3.5	0.05- 0.15	0.20- 0.80	16.0- 21.0	0.50- 2.00	...	0.04	0.015	...	...	...	0.10- 0.50	0.001- 0.10	0.005- 0.10	0.10- 0.30	0.02 max	0.30 max	0.3- 1.25			
Ni-Cr-W-Mo Alloys N06230	remainder A	20.0- 24.0	1.0- 3.0	3.0 max	13.0- 15.0	0.05- 0.15	0.25- 0.75	5.0 max	0.30- 1.00	...	0.03	0.015	...	...	...	0.50 max	...	0.005- 0.050	...	0.015 max	...	...			
Low C-Ni- Cr-Mo-Cu Alloy N06200	remainder A	22.0- 24.0	15.0- 17.0	3.0 max	...	0.010 max	0.08	2.0 max	0.50 max	...	0.025	0.010	...	1.3- 1.9	...	0.50 max	...	...	...	...	...	...			
Low C-Ni- Mo-Cr Alloy N10362	remainder A	13.8- 15.6	21.5- 23.0	1.25 max	...	0.010 max	0.08	...	0.60 max	...	0.025	0.010	...	...	...	0.50 max	...	...	...	...	...	...			
Low C-Ni- Fe-Cr- Mo-Cu Alloys N08031	30.0-32.0	26.0- 28.0	6.0- 7.0	balance	...	0.015 max	0.3	...	2.0 max	...	0.020	0.010	...	1.0- 1.4	...	...	...	...	0.15- 0.25	...	...	...			
N08034	33.5-35.0	26.0- 27.0	6.0- 7.0	balance	...	0.01 max	0.1	...	1.0- 4.0	...	0.020	0.010	...	0.5- 1.5	...	0.3 max	...	...	0.10- 0.25	...	...	...			
N08535	29.0-36.5	24.0- 27.0	2.5- 4.0	remainder A	...	0.03 max	0.50	...	1.0 max	...	0.03	0.03	...	1.50 max	...	...	...	...	...	...	...	...			
Low C-Ni- Cr-Mo-W Alloy N06686	remainder A	19.0- 23.0	15.0- 17.0	5.0 max	3.0- 4.4	0.010 max	0.08	...	0.75 max	...	0.04	0.02	0.02- 0.25	...	...	...	...	...	...	...	...	...			
Ni-Co-Cr-Si Alloy N12160	remainder A	26.0- 30.0	1.0 max	3.5 max	1.0 max	0.15 max	2.4- 3.0	27.0- 33.0	1.5 max	...	0.030	0.015	0.20- 0.80	...	...	...	...	...	...	...	1.0 max	...	...		
Cr-Ni-Fe-N Alloy R20033	30.0-33.0	31.0- 35.0	0.50- 2.0	balance	...	0.015 max	0.50	...	2.0 max	...	0.02	0.01	...	0.3- 1.20	...	...	...	...	0.35- 0.60	...	...	...			
Low C-Ni- Mo-Cr-Ta Alloy N06210	remainder A	18.0- 20.0	18.0- 20.0	1.0 max	...	0.015 max	0.08	1.0 max	0.5 max	0.35 max	0.02	0.02	...	...	...	...	...	...	...	...	...	1.5- 2.2			

<sup>A</sup> The composition of the remainder element shall be determined by the arithmetic difference.

ASME BPVC.II.B (ASME BPVC Section II part B) 2025

5.1.3 *Ends*—Plain ends cut and deburred will be furnished.

5.1.4 DELETED

5.1.5 *Samples for Check Analysis*—State whether samples for check analysis should be furnished.

5.1.6 *Purchaser Inspection*—If the purchaser wishes to witness tests or inspection of material at the place of manufacture, the purchase order must so state, indicating which tests or inspections are to be witnessed (Section 14).

## 6. Chemical Composition

6.1 The material shall conform to the composition limits specified in Table 1.

6.2 If a product (check) analysis is made by the purchaser, the material shall conform to the requirements specified in Table 1 subject to the permissible tolerances in accordance with Specification B829.

## 7. Mechanical Properties

7.1 The mechanical properties of the material at room temperature shall conform to those shown in Table 2.

## 8. Hydrostatic Test or Non-Destructive Electric Test

8.1 Each pipe or tube shall be tested by the manufacturer by either hydrostatic or a non-destructive electric test in accordance with Specification B829. Hydrostatic testing at a pressure greater than 1000 psi may be performed upon agreement between the purchaser and manufacturer or at the option of the manufacturer provided that the allowable fiber stress per Specification B829 is not exceeded.

TABLE 2 Mechanical Properties of Pipe and Tube

Alloy	Tensile Strength, min, ksi (MPa)	Yield Strength (0.2 % Offset) min, ksi (MPa)	Elongation in 2 in. (50.8 mm) or 4D, <sup>A</sup> min, %
<b>Ni-Mo</b>			
UNS N10001	100 (690)	45 (310)	40
UNS N10665	110 (760)	51 (350)	40
UNS N10675	110 (760)	51 (350)	40
UNS N10629	110 (760)	51 (350)	40
UNS N10624	104 (720)	46 (320)	40
<b>Ni-Mo-Cr-Fe</b>			
UNS N10242	105 (725)	45 (310)	40
<b>Low C Ni-Cr-Mo</b>			
UNS N10276	100 (690)	41 (283)	40
UNS N06022	100 (690)	45 (310)	45
UNS N06035	85 (586)	35 (241)	30
UNS N06044	100 (690)	45 (310)	30
UNS N06455	100 (690)	40 (276)	40
<b>Ni-Cr-Fe-Mo-Cu</b>			
UNS N06007	90 (621)	35 (241)	35
UNS N06975	85 (586)	32 (221)	40
UNS N06985	90 (621)	35 (241)	40
UNS N06030	85 (586)	35 (241)	30
UNS N06255	85 (586)	32 (221)	40
UNS N06250	90 (621)	35 (241)	40
<b>Ni-Fe-Cr-Mo</b>			
UNS N08320	75 (517)	28 (193)	35
UNS N08135	73 (503)	31 (214)	40
<b>Ni-Cr-Mo-Fe</b>			
UNS N06002	100 (690)	40 (276)	35
UNS N06060	90 (621)	35 (241)	40
Ni-Fe-Cr	100 (690)	45 (310)	40
<b>Co-R30556</b>			
<b>Ni-Cr-W-Mo</b>			
UNS N06230 <sup>B</sup>	110 (760)	45 (310)	40
<b>Low C-Ni-Cr-Mo</b>			
UNS N06058	110 (760)	52 (360)	40
UNS N06059	100 (690)	45 (310)	45
<b>Low C-Ni-Cr-Mo-Cu</b>			
UNS N06200	100 (690)	45 (310)	45
<b>Low C-Ni-Mo-Cr</b>			
UNS N10362	105 (725)	45 (310)	40
<b>Ni-Fe-Cr-Mo-Cu low carbon</b>			
UNS N08031	94 (650)	40 (276)	40
UNS N08034	94 (650)	40 (280)	40
UNS N08535	73 (503)	31 (214)	40
<b>Low C Ni-Cr-Mo-W</b>			
UNS N06686	100 (690)	45 (310)	45
<b>Ni-Co-Cr-Si</b>			
UNS N12160	90 (620)	35 (240)	40
<b>low carbon Cr-Ni-Fe-N</b>			
UNS R20033	109 (750)	55 (380)	40
<b>Low carbon Ni-Mo-Cr-Ta</b>			
UNS N06210	100 (690)	45 (310)	45

<sup>A</sup> D refers to the diameter of the tension specimen.

<sup>B</sup> Solution annealed at a minimum temperature of 2200°F (1204°C) followed by a water quench or rapidly cooled by other means.

## 9. Weight

9.1 For calculation of mass or weight, the following densities shall be used:

Alloy	Density	
	lb/in. <sup>3</sup>	g/cm <sup>3</sup>
Nickel-molybdenum:		
UNS N10001	0.334	9.24
UNS N10242	0.327	9.05
UNS N10665	0.333	9.22
UNS N10675	0.333	9.22
UNS N10629	0.333	9.22
UNS N10624	0.322	8.9
Low carbon nickel-chromium-molybdenum:		
UNS N10276	0.321	8.87
UNS N06022	0.314	8.69
UNS N06035	0.296	8.18
UNS N06044	0.287	7.97
UNS N06455	0.312	8.64
Nickel-chromium-iron-molybdenum-copper:		
UNS N06007	0.300	8.31
UNS N06975	0.295	8.17
UNS N06985	0.300	8.31
UNS N06030	0.297	8.22
UNS N06255	0.299	8.29
UNS N06250	0.307	8.58
Nickel-iron-chromium-molybdenum:		
UNS N08320	0.291	8.05
UNS N08135	0.292	8.10
Nickel-chromium-molybdenum-iron:		
UNS N06002	0.297	8.23
UNS N06060	0.315	8.71
Nickel-iron-chromium-cobalt:		
UNS R30556	0.297	8.23
Nickel-chromium-tungsten-molybdenum:		
UNS N06230	0.324	8.97
Low carbon nickel-chromium-molybdenum:		
UNS N06058	0.318	8.80
UNS N06059	0.311	8.6
UNS N06200	0.307	8.50
Low carbon nickel-molybdenum-chromium:		
UNS N10362	0.319	8.83
Low carbon nickel-iron-chromium-molybdenum-copper:		
UNS N08031	0.29	8.1
UNS N08034	0.293	8.10
UNS N08535	0.291	8.07
Low carbon nickel-chromium-molybdenum-tungsten:		
UNS N06686	0.315	8.73
Nickel-cobalt-chromium-silicon:		
UNS N12160	0.292	8.08
Low carbon chromium-nickel-iron-nitrogen:		
UNS R20033	0.29	8.1
Low carbon nickel-molybdenum-chromium-tantalum:		
UNS N06210	0.316	8.76

## 10. Sampling

10.1 *Lots for Chemical Analysis and Mechanical Testing are as defined in Specification B829.*

### 10.2 Sampling of Chemical Analysis:

10.2.1 A representative sample shall be taken from each lot during pouring or subsequent processing.

10.2.2 Product (check) analysis shall be wholly the responsibility of the purchaser.

### 10.3 Sampling for Mechanical Testing:

10.3.1 A representative sample shall be taken from each lot of finished material.

## 11. Number of Tests and Retests

11.1 *Chemical Analysis*—One test per lot.

11.2 *Tension Test*—One test per lot.

11.3 *Retests*—If the specimen used in the mechanical test of any lot fails to meet the specified requirements, two additional specimens shall be taken from different sample pieces and tested. The results of the tests on both of these specimens shall meet the specified requirements.

## 12. Specimen Preparation

12.1 Tension test specimens shall be taken from material after final heat treatment and tested in the direction of fabrication.

12.2 Whenever possible, all pipe and tube shall be tested in full tubular size. When testing in full tubular size is not possible, longitudinal strip specimens, or the largest possible round specimen prepared in accordance with Test Methods E8, shall be used.

## 13. Test Methods

13.1 The chemical composition and mechanical properties of the material as enumerated in this specification shall be determined in accordance with the methods in Specification B829.

## 14. Inspection

14.1 Inspection of the material shall be in accordance with this specification and agreements between the manufacturer and the purchaser as part of the purchase contract.

## 15. Certification

15.1 A manufacturer's certification shall be furnished to the purchaser stating that material has been manufactured, tested and inspected in accordance with this specification, and that the test results on representative samples meet specification requirements. A report of the test results shall be furnished.

## 16. Keywords

16.1 seamless pipe; seamless tube; UNS N06002; UNS N06007; UNS N06022; UNS N06030; UNS N06035; UNS N06044; UNS N06058; UNS N06059; UNS N06060; UNS N06200; UNS N06210; UNS N06230; UNS N06250; UNS N06255; UNS N10362; UNS N06455; UNS N06686; UNS N06975; UNS N06985; UNS N08031; UNS N08034; UNS N08135; UNS N08320; UNS N08535; UNS N10001; UNS N10242; UNS N10276; UNS N10624; UNS N10629; UNS N10665; UNS N10675; UNS N12160; UNS R20033; UNS R30556

## APPENDIXES

## (Nonmandatory Information)

## X1. HEAT TREATMENT

X1.1 Proper heat treatment during or subsequent to fabrication is necessary for optimum performance and the manufacturer shall be consulted for details.

## X2. PIPE SCHEDULES

TABLE X2.1 Pipe Schedules<sup>A</sup>

Nominal Pipe Size, in.	Outside Diameter	Nominal Wall Thickness		
		Schedule No. 10	Schedule No. 40	Schedule No. 80
		Inches		
¼	0.540	0.065	0.088	...
⅜	0.675	0.065	0.091	0.126
½	0.840	0.083	0.109	0.147
¾	1.050	0.083	0.113	0.154
1	1.315	0.109	0.133	0.179
1¼	1.660	0.109	0.140	0.191
1½	1.900	0.109	0.145	0.200
2	2.375	0.109	0.154	0.218
2½	2.875	0.120	0.203	0.276
3	3.500	0.120	0.216	0.300
		Millimetres		
¼	13.72	1.65	2.24	...
⅜	17.14	1.65	2.31	3.20
½	21.34	2.11	2.77	3.73
¾	26.67	2.11	2.87	3.91
1	33.40	2.77	3.38	4.55
1¼	42.16	2.77	3.56	4.85
1½	48.26	2.77	3.68	5.08
2	60.32	2.77	3.91	5.54
2½	73.02	3.05	5.16	7.04
3	88.90	3.05	5.49	7.62

<sup>A</sup> The pipe schedules shown conform with standards adopted by the American National Standards Institute.

X2.1 The schedules listed in Table X2.1 are regularly available. This table is published for information only.

ASMENORMDOC.COM : Click to view the full PDF of ASME BPVC.II.B (ASME BPVC Section II part B) 2025

INTENTIONALLY LEFT BLANK

# SPECIFICATION FOR UNS N08925, UNS N08031, UNS N08034, UNS N08932, UNS N08926, UNS N08354, UNS N08830, AND UNS R20033 PLATE, SHEET, AND STRIP



SB-625



(25)

(Identical with ASTM Specification B625-17 except that certification and test reports have been made mandatory, and heat treatment requirements for UNS N08354 have been added.)

ASME SB-625 replaces 5.1.9 of ASTM B625, adds paras. 6 and 6.1, and redesignates former paras. 6 through 9.1 as 7 through 10.1, as follows:

5.1.9 Certification or test reports—Certification and test reports are required, and

## 6. Material and Manufacture

6.1 UNS N08354 shall be furnished in the solution annealed condition at a temperature range from 1975°F to 2155°F (1080°C to 1180°C) followed by rapid cooling in air or water.

## 7. Chemical Composition

7.1 The material shall conform to the composition limits specified in Table 1. One test per lot is required as defined in Specification B906.

7.2 If a product analysis is made by the purchaser, the material shall conform to the product (check) analysis variations in Specification B906.

## 8. Mechanical Properties and Other Requirements

8.1 *Tensile and Hardness Requirements*—The material shall conform to the mechanical property requirements specified in Table 2. One test per lot is required as defined in Specification B906.

## 9. Dimensions and Permissible Variations

9.1 *Sheet*—The material shall be furnished in accordance with the dimensional requirements established in Specification B906.

**10. Keywords**

10.1 UNS N08031; UNS N08034; UNS N08925; UNS N08926; UNS N08932; UNS N08354; UNS N08830; UNS R20033;  
plate; sheet; strip

ASMENORMDOC.COM : Click to view the full PDF of ASME BPVC.II.B (ASME BPVC Section II part B) 2025



Designation: B625 – 17

## Standard Specification for UNS N08925, UNS N08031, UNS N08034, UNS N08932, UNS N08926, UNS N08354, UNS N08830, and UNS R20033 Plate, Sheet, and Strip<sup>1</sup>

This standard is issued under the fixed designation B625; the number immediately following the designation indicates the year of original adoption or, in the case of revision, the year of last revision. A number in parentheses indicates the year of last reapproval. A superscript epsilon ( $\epsilon$ ) indicates an editorial change since the last revision or reapproval.

### 1. Scope\*

1.1 This specification covers alloys UNS N08925, UNS N08031, UNS N08034, UNS N08932, UNS N08926, UNS N08354, UNS N08830, and UNS R20033 plate, sheet, and strip in the annealed temper.

1.2 ASTM International has adopted definitions whereby some grades, such as UNS N08904, previously in this specification were recognized as stainless steels, because those grades have iron as the largest element by mass percent. Such grades are under the oversight of ASTM Committee A01 and its subcommittees. The products of N08904 previously covered in this specification are now covered by Specifications A240/A240M and A480/A480M.

1.3 The values stated in inch-pound units are to be regarded as standard. The values given in parentheses are mathematical conversions to SI units that are provided for information only and are not considered standard.

1.4 *This standard does not purport to address all of the safety concerns, if any, associated with its use. It is the responsibility of the user of this standard to become familiar with all hazards including those identified in the appropriate Safety Data Sheet (SDS) for this product/material as provided by the manufacturer, to establish appropriate safety, health and environmental practices, and determine the applicability of regulatory limitations prior to use.*

1.5 *This international standard was developed in accordance with internationally recognized principles on standardization established in the Decision on Principles for the Development of International Standards, Guides and Recommendations issued by the World Trade Organization Technical Barriers to Trade (TBT) Committee.*

<sup>1</sup>This specification is under the jurisdiction of ASTM Committee B02 on Nonferrous Metals and Alloys and is the direct responsibility of Subcommittee B02.07 on Refined Nickel and Cobalt and Their Alloys.

Current edition approved July 1, 2017. Published August 2017. Originally approved in 1977. Last previous edition approved in 2014 as B625 – 14. DOI: 10.1520/B0625-17.

### 2. Referenced Documents

#### 2.1 ASTM Standards:

- A240/A240M Specification for Chromium and Chromium-Nickel Stainless Steel Plate, Sheet, and Strip for Pressure Vessels and for General Applications
- A480/A480M Specification for General Requirements for Flat-Rolled Stainless and Heat-Resisting Steel Plate, Sheet, and Strip
- B906 Specification for General Requirements for Flat-Rolled Nickel and Nickel Alloys Plate, Sheet, and Strip
- E527 Practice for Numbering Metals and Alloys in the Unified Numbering System (UNS)

### 3. Terminology

#### 3.1 Definitions of Terms Specific to This Standard:

- 3.1.1 *plate, n*—material  $\frac{3}{16}$  in. (4.76 mm) and over in thickness and over 10 in. (254 mm) in width.
- 3.1.2 *sheet, n*—material under  $\frac{3}{16}$  in. (4.76 mm) in thickness and 24 in. (609.6 mm) and over in width. Material under  $\frac{3}{16}$  in. (4.75 mm) in thickness and in all widths with No. 4 finish.
- 3.1.3 *strip, n*—material under  $\frac{3}{16}$  in. (4.76 mm) in thickness and under 24 in. (609.6 mm) in width.

### 4. General Requirements

4.1 Material furnished in accordance with this specification shall conform to the applicable requirements of the current edition of Specification B906 unless otherwise provided herein.

### 5. Ordering Information

5.1 Orders for material under this specification shall include the following information:

- 5.1.1 Quantity (weight or number of pieces),
- 5.1.2 Alloy name or UNS number,
- 5.1.3 Form, plate, sheet or strip,

<sup>2</sup>For referenced ASTM standards, visit the ASTM website, www.astm.org, or contact ASTM Customer Service at service@astm.org. For *Annual Book of ASTM Standards* volume information, refer to the standard's Document Summary page on the ASTM website.

\*A Summary of Changes section appears at the end of this standard

TABLE 1 Chemical Requirements<sup>A</sup>

Elements	UNS N08925	UNS N08932	UNS N08354	UNS N08034	UNS N08031	UNS N08926	UNS N08830	UNS R20033
Carbon	0.020	0.020	0.030	0.01	0.015	0.020	0.015	0.015
Manganese	1.00	2.00	1.00	1.0-4.0	2.0	2.00	3.0-6.0	2.0
Phosphorus	0.045	0.025	0.030	0.020	0.020	0.03	0.035	0.02
Sulfur	0.030	0.010	0.010	0.010	0.010	0.01	0.010	0.01
Silicon	0.50	0.40	1.00	0.1	0.3	0.5	1.00	0.50
Nickel	24.00-26.00	24.0-26.0	34.0-36.0	33.5-35.0	30.0-32.0	24.00-26.00	29.0-34.0	30.0-33.0
Chromium	19.00-21.00	24.0-26.0	22.0-24.0	26.0-27.0	26.0-28.0	19.00-21.00	20.0-24.0	31.0-35.0
Molybdenum	6.0-7.0	4.5-6.5	7.0-8.0	6.0-7.0	6.0-7.0	6.0-7.0	4.5-6.5	0.50-2.0
Copper	0.8-1.5	1.0-2.0	...	0.5-1.5	1.0-1.4	0.5-1.5	0.50-2.00	0.30-1.20
Cobalt	...	...	...	...	...	...	0.50-3.5	...
Tungsten	...	...	...	...	...	...	0.20-1.80	...
Nitrogen	0.10-0.20	0.15-0.25	0.17-0.24	0.10-0.25	0.15-0.25	0.15-0.25	0.20-0.55	0.35-0.60
Iron	balance	balance	balance	balance	balance	balance	balance	balance
Aluminum	...	...	...	0.3	...	...	...	...

<sup>A</sup> Maximum %, unless range or minimum is indicated.

TABLE 2 Mechanical Property Requirements

Alloy	Form	Tensile Strength, min, ksi (MPa)	Yield Strength (0.2 % offset), min, psi (MPa)	Elongation in 2 in. or 50.8 mm, or 4D, min, %
UNS N08925	sheet	87 (600)	43 000 (295)	40
	strip	87 (600)	43 000 (295)	40
	plate	87 (600)	43 000 (295)	40
UNS N08932	plate	87 (600)	44 000 (305)	40
UNS N08031	sheet	94 (650)	40 000 (276)	40
	strip	94 (650)	40 000 (276)	40
	plate	94 (650)	40 000 (276)	40
UNS N08034	sheet	94 (650)	40 000 (280)	40
	strip	94 (650)	40 000 (280)	40
	plate	94 (650)	40 000 (280)	40
UNS N08926	sheet	94 (650)	43 000 (295)	35
	strip	94 (650)	43 000 (295)	35
	plate	94 (650)	43 000 (295)	35
UNS N08354	sheet	93 (640)	43 000 (295)	40
	strip	93 (640)	43 000 (295)	40
	plate	93 (640)	43 000 (295)	40
UNS N08830	sheet	110 (760)	55 000 (380)	40
	strip	110 (760)	55 000 (380)	40
	plate	110 (760)	55 000 (380)	40
UNS R20033	sheet	109 (750)	55 000 (380)	40
	strip	109 (750)	55 000 (380)	40
	plate	109 (750)	55 000 (380)	40

5.1.4 Dimensions,

5.1.5 Type edge required, for strip only (see Specification B906),

5.1.6 Finish (see Specification B906)—For sheet with No. 4 finish, specify whether one or both sides are to be polished,

5.1.7 ASTM designation,

5.1.8 Additions to the specification or special requirements,

5.1.9 Certification or test reports—State if certification or test reports are required, and

5.1.10 Source inspection—State if inspection is required.

**6. Chemical Composition**

6.1 The material shall conform to the composition limits specified in Table 1. One test per lot is required as defined in Specification B906.

6.2 If a product analysis is made by the purchaser, the material shall conform to the product (check) analysis variations in Specification B906.

**7. Mechanical Properties and Other Requirements**

7.1 *Tensile and Hardness Requirements*—The material shall conform to the mechanical property requirements specified in Table 2. One test per lot is required as defined in Specification B906.

**8. Dimensions and Permissible Variations**

8.1 *Sheet*—The material shall be furnished in accordance with the dimensional requirements established in Specification B906.

**9. Keywords**

9.1 UNS N08031; UNS N08034; UNS N08925; UNS N08926; UNS N08932; UNS N08354; UNS N08830; UNS R20033; plate; sheet; strip

## SUMMARY OF CHANGES

Committee B02 has identified the location of selected changes to this standard since the last issue (B625-14) that may impact the use of this standard. (Approved July 1, 2017.)

- |  |   |
|--|---|
| (1) Changed the title to include new alloy.          | (4) Added Mechanical property data to Table 2 for UNS N08034. |
| (2) Added new alloy UNS N08034 to scope (Section 1). | (5) Added UNS N08034 to Keywords in Section 9.                |
| (3) Added chemistry data for UNS N08034 to Table 1.  |   |

*ASTM International takes no position respecting the validity of any patent rights asserted in connection with any item mentioned in this standard. Users of this standard are expressly advised that determination of the validity of any such patent rights, and the risk of infringement of such rights, are entirely their own responsibility.*

*This standard is subject to revision at any time by the responsible technical committee and must be reviewed every five years and if not revised, either reapproved or withdrawn. Your comments are invited either for revision of this standard or for additional standards and should be addressed to ASTM International Headquarters. Your comments will receive careful consideration at a meeting of the responsible technical committee, which you may attend. If you feel that your comments have not received a fair hearing you should make your views known to the ASTM Committee on Standards, at the address shown below.*

*This standard is copyrighted by ASTM International, 100 Barr Harbor Drive, PO Box C700, West Conshohocken, PA 19428-2959, United States. Individual reprints (single or multiple copies) of this standard may be obtained by contacting ASTM at the above address or at 610-832-9585 (phone), 610-832-9555 (fax), or service@astm.org (e-mail); or through the ASTM website (www.astm.org). Permission rights to photocopy the standard may also be secured from the Copyright Clearance Center, 222 Rosewood Drive, Danvers, MA 01923, Tel: (978) 646-2600; <http://www.copyright.com/>*

ASMENORMDOC.COM : Click to view the full PDF of ASME BPVC.II.B (ASME BPVC Section II part B) 2025

INTENTIONALLY LEFT BLANK

# SPECIFICATION FOR WELDED NICKEL AND NICKEL-COBALT ALLOY TUBE



**SB-626**

(Identical with ASTM Specification B626-17 except certification and test reports have been made mandatory per para. 5.1.6 and in SB-751.)

## Specification for Welded Nickel and Nickel-Cobalt Alloy Tube

### 1. Scope

1.1 This specification covers welded tubes made from the nickel and nickel-cobalt alloys (UNS N10001, UNS N10242, UNS N10665, UNS N12160, UNS N10629, UNS N10624, UNS N10675, UNS N10276, UNS N06455, UNS N06007, UNS N06975, UNS N08320, UNS N06985, UNS N06002, UNS N06022, UNS N06030, UNS N06035, UNS N06044, UNS N06058, UNS N06059, UNS N06200, UNS N06617, UNS N10362, UNS N06210, UNS N08031, UNS R30556, UNS N06230, UNS N06686, and UNS R20033) listed in Table 1 intended for heat exchanger and condenser tubes and tubes for general corrosive service for heat-resisting applications.

1.2 This specification covers tube  $\frac{1}{8}$  to  $3\frac{1}{2}$  in. (3.2 to 88.9 mm) in outside diameter and 0.015 to 0.148 in. (0.41 to 3.7 mm) inclusive, in wall thickness.

1.3 The values stated in inch-pound units are to be regarded as standard. The values given in parentheses are mathematical conversions to SI units that are provided for information only and are not considered standard.

1.4 *This standard does not purport to address all of the safety concerns, if any, associated with its use. It is the responsibility of the user of this standard to become familiar with all hazards including those identified in the appropriate Safety Data Sheet (SDS) for this product/material as provided by the manufacturer, to establish appropriate safety and health practices, and determine the applicability of regulatory limitations prior to use.*

1.5 *This international standard was developed in accordance with internationally recognized principles on standardization established in the Decision on Principles for the Development of International Standards, Guides and Recommendations issued by the World Trade Organization Technical Barriers to Trade (TBT) Committee.*

### 2. Referenced Documents

#### 2.1 ASTM Standards:

B751 Specification for General Requirements for Nickel and Nickel Alloy Welded Tube  
E527 Practice for Numbering Metals and Alloys in the Unified Numbering System (UNS)

### 3. General Requirements

3.1 Material furnished in accordance with this specification shall conform to the applicable requirements of the current edition of Specification B751 unless otherwise provided herein.

### 4. Classification

4.1 Five classes of tube are covered as follows:

4.1.1 *Class IA*—Welded, sized, solution annealed, and non-destructively tested in accordance with 4.2.1.

4.1.2 *Class IB*—Welded, sized, and solution annealed.

4.1.3 *Class IIA*—Welded, cold worked, solution annealed, and nondestructively tested in accordance with 4.2.1.

4.1.4 *Class IIB*—Welded, cold worked, and solution annealed.

4.1.5 *Class III*—Welded, cold worked, solution annealed, and nondestructively tested in accordance with 4.2.2.

#### 4.2 Nondestructive Tests:

4.2.1 *Class IA and Class IIA Tubes*—Each finished tube shall be subjected to the hydrostatic test, the pneumatic test, or the eddy current test at the manufacturer's option.

4.2.2 *Class III Tubes*—Each finished tube shall be subjected to the pneumatic test and the eddy current test. Tubes larger than  $1\frac{1}{2}$  in. (38.1 mm) in outside diameter may be subjected to the hydrostatic test in lieu of the pneumatic test at the manufacturer's option.

### 5. Ordering Information

5.1 It is the responsibility of the purchaser to specify all requirements that are necessary for material ordered under this

TABLE 1 Chemical Requirements

	Composition Limits, %																								
	Ni	Cr	Mo	Fe	W	C	Si max	Co	Mn	V	P max	S max	Ti	Cu	Cb (Nb) +Ta	Al	Zr	La	N	B	Cb (Nb)	Ta	Ni+ Mo	Mg	
Ni-Mo Alloys N10001	remainder	1.0 max	26.0- 30.0	4.0-6.0	...	0.05 max	1.0	2.5	1.0	0.2- 0.4	0.04	0.03	...	...	...										
N10665	remainder	1.0 max	26.0- 30.0	2.0 max	...	0.02 max	0.10	1.0	1.0	...	0.04	0.03	...	...	...										
N10675	65.0 min	1.0- 3.0	27.0- 32.0	1.0-3.0	3.0 max	0.01 max	0.10	3.0	3.0	0.20 max	0.030	0.010	0.20 max	0.20 max	...	0.50 max	0.10 max	...	...	...	0.20 max	0.20 max	94.0- 98.0		
N10629	remainder	0.5- 1.5	26.0- 30.0	1.0-6.0	...	0.01 max	0.05	2.5	1.5	...	0.04	0.01	...	0.5 max	...	0.1- 0.5	...	...	...	...	...	...	...	...	
N10624	remainder	6.0- 10.0	21.0- 25.0	5.0-8.0	...	0.01 max	0.10	1.0	1.0	...	0.025	0.01	...	0.5 max	...	...	...	...	...	...	...	...	...	...	
Ni-Mo-Cr-Fe Alloy N10242	remainder	7.0- 9.0	24.0- 26.0	2.0 max	...	0.03 max	0.80	1.00 max	0.80 max	...	0.030	0.015	...	0.50 max	...	0.50 max	...	...	...	...	0.006 max	...	...	...	
Low C Ni- Cr-Mo Alloys N10276	remainder	14.5- 16.5	15.0- 17.0	4.0-7.0	3.0- 4.5	0.010 max	0.08	2.5 max	1.0 max	0.35 max	0.04	0.03	...	...	...										
N06022	remainder	20.0- 22.5	12.5- 14.5	2.0-6.0	2.5- 3.5	0.015 max	0.08	2.5 max	0.5 max	0.35 max	0.02	0.02	...	...	...										
N06035	remainder	32.25- 34.25	7.60- 9.00	2.00 max	0.60 max	0.050 max	0.60	1.00 max	0.50 max	0.20 max	0.030	0.015	...	0.30 max	...	0.40 max	...	...	...	...	...	...	...	...	
N06044	balance	43.5- 45.3	0.80- 1.20	0.3 max	...	0.02 max	0.20	...	0.07- 0.30	...	0.020	0.020	0.10- 0.30	...	...	0.30 max	...	...	...	...	...	...	...	...	
N06058	balance	20.0- 23.0	18.5- 21.0	1.5 max	0.3 max	0.010 max	0.10	0.3 max	0.50 max	...	0.015	0.010	...	0.50 max	...	0.40 max	...	...	0.02- 0.15	...	...	...	...	...	
N06059	balance	22.0- 24.0	15.0- 16.5	1.5 max	...	0.010 max	0.10	0.3 max	0.5 max	...	0.015	0.010	...	0.50 max	...	0.1- 0.4	...	...	...	...	...	...	...	...	
N06455	remainder	14.0- 18.0	14.0- 17.0	3.0 max	...	0.015 max	0.08	2.0 max	1.0 max	...	0.04	0.03	0.70 max	...	...	...	...	...	...	...	...	...	...	...	
Ni-Cr-Fe- Mo-Cu Alloys N06007	remainder	21.0- 23.5	5.5- 7.5	18.0-21.0	1.0 max	0.05 max	1.0	2.5 max	1.0- 2.0	...	0.04	0.03	...	1.5- 2.5	1.75- 2.5	...	...	...	...	...	...	...	...	...	
N06975	47.0-52.0	23.0- 26.0	5.0- 7.0	remainder	...	0.03 max	1.0	...	1.0 max	...	0.03	0.03	0.70- 1.50	0.70- 1.20	...	...	...	...	...	...	...	...	...	...	
N06985	remainder	21.0- 23.5	6.0- 8.0	18.0-21.0	1.5 max	0.015 max	1.0	5.0 max	1.0 max	...	0.04	0.03	...	1.5- 2.5	0.50 max	...	...	...	...	...	...	...	...	...	
N06030	remainder	28.0- 31.5	4.0- 6.0	13.0-17.0	1.5- 4.0	0.03 max	0.8	5.0 max	1.5 max	...	0.04	0.02	...	1.0- 2.4	0.30- 1.50	...	...	...	...	...	...	...	...	...	
Ni-Fe-Cr-Mo Alloys N08320	25.0-27.0	21.0- 23.0	4.0- 6.0	remainder	...	0.05 max	1.0	...	2.5 max	...	0.04	0.03	4xC min	...	...	...	...	...	...	...	...	...	...	...	
Ni-Cr-Mo-Fe Alloy N06002	remainder	20.5- 23.0	8.0- 10.0	17.0-20.0	0.20- 1.0	0.05- 0.15	1.0	0.5- 2.5	1.0 max	...	0.04	0.03	...	...	...	...	...	...	...	...	...	...	...	...	
Ni-Fe-Cr-Co Alloy R30556	19.0-22.5	21.0- 23.0	2.5- 4.0	remainder	2.0- 3.5	0.05- 0.15	0.20- 0.80	16.0- 21.0	0.50- 2.00	...	0.04	0.015	...	...	...	0.10- 0.50	0.001- 0.10	0.005- 0.10	0.10- 0.30	0.02 max	0.30 max	0.3- 1.25	...	...	

ASME BPVC.II.B (ASME BPVC Section II part B) 2025

TABLE 1 Continued

	Composition Limits, %																							
	Ni	Cr	Mo	Fe	W	C	Si max	Co	Mn	V	P max	S max	Ti	Cu	Cb (Nb) +Ta	Al	Zr	La	N	B	Cb (Nb)	Ta	Ni+ Mo	Mg
Ni-Cr-W-Mo Alloy N06230	remainder	20.0-24.0	1.0-3.0	3.0 max	13.0-15.0	0.05-0.15	0.25-0.75	5.0 max	0.30-1.00	...	0.03	0.015	...	...	...	0.50 max	...	0.005-0.050	...	0.015 max	...	...	...	...
Low C-Ni-Cr-Mo-Cu Alloy N06200	remainder	22.0-24.0	15.0-17.0	3.0 max	...	0.010 max	0.08	2.0 max	0.50 max	...	0.025	0.010	...	1.3-1.9	...	0.50 max	...	...	...	...	...	...	...	...
Ni-Cr-Co-Mo Alloys N06617	44.5 min	20.0-24.0	8.0-10.0	3.0 max	...	0.05-0.15	1.0	10.0-15.0	1.0 max	...	...	0.015	0.6 max	0.5 max	...	0.8-1.5	...	...	...	0.006	...	...	...	...
Low C-Ni-Mo-Cr Alloy N10362	remainder	13.8-15.6	21.5-23.0	1.25 max	...	0.010 max	0.08	...	0.60 max	...	0.025	0.010	...	...	...	0.50 max	...	...	...	...	...	...	...	...
Low C-Ni-Fe-Cr-Mo-Cu Alloy N08031	30.0-32.0	26.0-28.0	6.0-7.0	balance	...	0.015 max	0.3	...	2.0 max	...	0.020	0.010	...	1.0-1.4	...	...	...	...	0.15-0.25	...	...	...	...	...
Low C-Ni-Cr-Mo-W Alloy N06686	remainder	19.0-23.0	15.0-17.0	5.0 max	3.0-4.4	0.010 max	0.08	...	0.75 max	...	0.04	0.02	0.02-0.25	...	...	...	...	...	...	...	...	...	...	...
Ni-Co-Cr-Si Alloy N12160	remainder	26.0-30.0	1.0 max	3.5 max	1.0 max	0.15 max	2.4-3.0	27.0-33.0	1.5 max	...	0.030	0.015	0.20-0.80	...	...	...	...	...	...	...	1.0 max	...	...	...
Cr-Ni-Fe-N Alloy R20033	30.0-33.0	31.0-35.0	0.50-2.0	balance	...	0.015 max	0.50	...	2.0 max	...	0.02	0.01	...	0.3-1.20	...	...	...	...	0.35-0.60	...	...	...	...	...
Low C-Ni-Mo-Cr-Ta Alloy N06210	remainder	18.0-20.0	18.0-20.0	1.0 max	...	0.015 max	0.08	1.0 max	0.5	0.35 max	0.02	0.02	...	...	...	...	...	...	...	...	...	1.5-2.2	...	...

ASME NORMDOC.COM · Click to view the full PDF of ASME BPVC.II.B (ASME BPVC Section II part B) 2025

specification. Examples of such requirements include, but are not limited to the following:

- 5.1.1 *Alloy* (Table 1),
- 5.1.2 *Class* (see 4),
- 5.1.3 *Quantity* (feet or number of lengths),
- 5.1.4 *Size* (outside diameter and average wall thickness),
- 5.1.5 *Length* (cut or random),
- 5.1.6 *Certification*—Certification and a report of test results are required (SB-571),
- 5.1.7 *Purchaser Inspection*—State which tests or inspections are to be witnessed,
- 5.1.8 *Ends*—Plain ends cut and deburred will be furnished, unless otherwise specified, and
- 5.1.9 *Samples for Product (Check) Analysis*—State whether samples shall be furnished.

## 6. Materials and Manufacture

6.1 The tubes shall be made from flat-rolled alloy by an automatic welding process with no addition of filler metal.

6.2 Subsequent to welding and prior to final heat treatment, Class II and Class III tubes shall be cold worked either in both weld and base metal or in weld metal only. The method and amount of cold working may be specified by the purchaser. When cold drawn, the purchaser may specify the minimum amount of reduction in cross-sectional area or wall thickness, or both.

6.3 All tubes shall be furnished in the solution annealed and descaled condition. When atmosphere control is used, descaling is not necessary.

## 7. Chemical Composition

7.1 The material shall conform to the requirements for chemical composition prescribed in Table 1. One test is required for each lot as defined in Specification B751.

7.2 If a product (check) analysis is performed by the purchaser, the material shall conform to the requirements specified in Table 1 subject to permissible variations specified in Specification B751.

## 8. Mechanical Properties and Other Requirements

8.1 *Mechanical Properties*—The material shall conform to the mechanical properties prescribed in Table 2. One test is required for each lot as defined in Specification B751.

8.2 *Flattening Test Requirements:*

8.2.1 Evidence of laminated or unsound material or of incomplete weld that is revealed during the entire flattening test shall be cause for rejection.

8.2.2 Surface imperfections in the test specimens before flattening, but revealed during the flattening test, shall be judged in accordance with the finish requirements.

8.2.3 Superficial ruptures resulting from surface imperfections shall not be cause for rejection.

8.2.4 One test is required for each lot as defined in Specification B751.

8.3 *Flange Test Requirements:*

TABLE 2 Mechanical Properties

Alloy	Tensile Strength, min, ksi (MPa)	Yield Strength (0.2 Offset) min, ksi (MPa)	Elongation in 2 in. (50.8 mm) or 4D <sup>A</sup> , min, %
Ni-Mo			
UNS N10001	100 (690)	45 (310)	40
UNS N10665	110 (760)	51 (350)	40
UNS N10675	110 (760)	51 (350)	40
UNS N10629	110 (760)	51 (350)	40
UNS N10624	104 (720)	46 (320)	40
Ni-Mo-Cr-Fe			
UNS N10242	105 (725)	45 (310)	40
Low C Ni-Cr-Mo			
UNS N10276	100 (690)	41 (283)	40
UNS N06022	100 (690)	45 (310)	45
UNS N06035	85 (586)	35 (241)	30
UNS N06044	90 (620)	45 (310)	20
UNS N06455	100 (690)	40 (276)	40
Ni-Cr-Fe-Mo-Cu			
UNS N06007	90 (621)	35 (241)	35
UNS N06975	85 (586)	32 (221)	40
UNS N06985	90 (621)	35 (241)	45
UNS N06030	85 (586)	35 (241)	30
Ni-Fe-Cr-Mo			
UNS N08320	75 (517)	28 (193)	35
Ni-Cr-Mo-Fe			
UNS N06002	100 (690)	40 (276)	35
Ni-Fe-Cr-Co			
UNS N06056	100 (690)	45 (310)	40
Ni-Cr-W-Mo			
UNS N06230 <sup>B</sup>	110 (760)	45 (310)	40
Low C-Ni-Cr-Mo			
UNS N06058	110 (760)	52 (360)	40
UNS N06059	100 (690)	45 (310)	45
Low C-Ni-Cr-Mo-Cu			
UNS N06200	100 (690)	45 (310)	45
Ni-Cr-Co-Mo			
UNS N06617	95 (665)	35 (240)	35
Low C-Ni-Mo-Cr			
UNS N10362	105 (725)	45 (310)	40
Low-carbon Ni-Fe-Cr-Mo-Cu			
UNS N08031	94 (650)	40 (276)	40
Low C-Ni-Cr-Mo-W			
UNS N06686	100 (690)	45 (310)	45
Ni-Co-Cr-Si			
UNS N12160	90 (620)	35 (240)	40
Low Carbon Cr-Ni-Fe-N			
UNS R20033	109 (750)	55 (380)	40
Low-C Ni-Mo-Cr-Ta			
UNS N06210	100 (690)	45 (310)	45

<sup>A</sup> D refers to the diameter of the tension specimen.

<sup>B</sup> Solution annealed at a minimum temperature of 2200°F (1204°C) followed by a water quench or rapidly cooled by other means.

8.3.1 Flange test specimens shall show no cracking or flaws. Superficial ruptures resulting from surface imperfections shall not be cause for rejection.

8.3.2 For tube less than 0.093 in. (2.36 mm) in inside diameter and tube having a wall thickness equal to or greater than the inside diameter, the flange test shall not be required.

8.3.3 One test is required for each lot as defined in Specification B751.

8.4 *Hydrostatic Test*—When tested by the manufacturer, each tube shall be subjected to the hydrostatic test per Specification B751.

8.5 *Pneumatic Test*—When tested by the manufacturer, each tube shall be subjected to the pneumatic test per Specification B751.

8.6 *Eddy Current Test*—When tested by the manufacturer, each tube shall be subjected to an electromagnetic (eddy current) test per Specification B751.

**9. Keywords**

9.1 UNS N10001; UNS N10242; UNS N10665; UNS N12160; UNS N10629; UNS N10624; UNS N10675; UNS

N10276; UNS N06455; UNS N06007; UNS N06975; UNS N08320; UNS N06985; UNS N06002; UNS N06022; UNS N06030; UNS N06035; UNS N06044; UNS N06058; UNS N06059; UNS N06200; UNS N06617; UNS N10362; UNS N06210; UNS N08031; UNS N06230; UNS N06686; UNS R30556; UNS R20033; welded tube

ASMENORMDOC.COM : Click to view the full PDF of ASME BPVC.II.B (ASME BPVC Section II part B) 2025

**SPECIFICATION FOR PRECIPITATION-HARDENING AND  
COLD WORKED NICKEL ALLOY BARS, FORGINGS, AND  
FORGING STOCK FOR MODERATE OR  
HIGH-TEMPERATURE SERVICE**



**SB-637**

(Identical with ASTM Specification B637-18 except certification and test reports have been made mandatory.)

# Specification for Precipitation-Hardening and Cold Worked Nickel Alloy Bars, Forgings, and Forging Stock for Moderate or High Temperature Service

## 1. Scope

1.1 This specification covers hot- and cold-worked precipitation-hardenable nickel alloy rod, bar, forgings, and forging stock for moderate or high temperature service (Table 1).

1.2 The values stated in inch-pound units are to be regarded as standard. The values given in parentheses are mathematical conversions to SI units that are provided for information only and are not considered standard.

1.3 *This standard does not purport to address all of the safety concerns, if any, associated with its use. It is the responsibility of the user of this standard to become familiar with all hazards including those identified in the appropriate Safety Data Sheet (SDS) for this product/material as provided by the manufacturer, to establish appropriate safety, health, and environmental practices, and determine the applicability of regulatory limitations prior to use.*

1.4 *This international standard was developed in accordance with internationally recognized principles on standardization established in the Decision on Principles for the Development of International Standards, Guides and Recommendations issued by the World Trade Organization Technical Barriers to Trade (TBT) Committee.*

## 2. Referenced Documents

### 2.1 ASTM Standards:

- B880 Specification for General Requirements for Chemical Check Analysis Limits for Nickel, Nickel Alloys and Cobalt Alloys
- E8/E8M Test Methods for Tension Testing of Metallic Materials
- E29 Practice for Using Significant Digits in Test Data to Determine Conformance with Specifications
- E139 Test Methods for Conducting Creep, Creep-Rupture, and Stress-Rupture Tests of Metallic Materials
- E140 Hardness Conversion Tables for Metals Relationship Among Brinell Hardness, Vickers Hardness, Rockwell Hardness, Superficial Hardness, Knoop Hardness, Scleroscope Hardness, and Leeb Hardness
- E1473 Test Methods for Chemical Analysis of Nickel, Cobalt and High-Temperature Alloys

## 3. Terminology

### 3.1 Definitions:

- 3.1.1 *bar, n*—material of rectangular (flats), hexagonal, octagonal, or square solid section in straight lengths.
- 3.1.2 *rod, n*—material of round solid section furnished in straight lengths.

## 4. Ordering Information

4.1 It is the responsibility of the purchaser to specify all requirements that are necessary for material ordered under this specification. Examples of such requirements include, but are not limited to, the following:

- 4.1.1 Alloy (Table 1).
- 4.1.2 Condition (temper or cold worked) (Tables 2 and 3 and 6.1).
- 4.1.3 *Shape*—Rod or bar (round, rectangle, square, hexagon, octagon).
  - 4.1.3.1 Forging (sketch or drawing).
- 4.1.4 *Dimensions*, including length.
- 4.1.5 Quantity (mass or number of pieces).
- 4.1.6 *Forging Stock*—Specify if material is stock for re-forging.
- 4.1.7 Finish.
- 4.1.8 DELETED

TABLE 1 Chemical Requirements

Element	Composition Limits, %							
	UNS N07022	UNS N07208	UNS N07252 (Formerly Grade 689)	UNS N07001 (Formerly Grade 685)	UNS N07500 (Formerly Grade 684)	UNS N07740	UNS N07750 (Formerly Grade 688)	UNS N07718 (Formerly Grade 718)
Carbon	0.010 max	0.04–0.08	0.10–0.20	0.03–0.10	0.15 max	0.005–0.08	0.08 max	0.08 max
Manganese	0.5 max	0.3 max	0.50 max	1.00 max	0.75 max	1.00 max	1.00 max	0.35 max
Silicon	0.08 max	0.15 max	0.50 max	0.75 max	0.75 max	1.00 max	0.50 max	0.35 max
Phosphorus	0.025 max	0.015 max	0.015 max	0.030 max	0.015 max	0.030 max	...	0.015 max
Sulfur	0.015 max	0.015 max	0.015 max	0.030 max	0.015 max	0.030 max	0.01 max	0.015 max
Chromium	20.0–21.4	18.5–20.5	18.00–20.00	18.00–21.00	15.00–20.00	23.50–25.50	14.00–17.00	17.0–21.0
Cobalt	1.0 max	9.0–11.0	9.00–11.00	12.00–15.00	13.00–20.00	15.00–22.00	1.00 max <sup>A</sup>	1.0 max <sup>A</sup>
Molybdenum	15.5–17.4	8.0–9.0	9.00–10.50	3.50–5.00	3.00–5.00	2.00 max	...	2.80–3.30
Columbium (Nb) + tantalum	...	...	...	...	...	...	0.70–1.20	4.75–5.50
Titanium	...	1.90–2.30	2.25–2.75	2.75–3.25	2.50–3.25	0.50–2.50	2.25–2.75	0.65–1.15
Aluminum	0.5 max	1.38–1.65	0.75–1.25	1.20–1.60	2.50–3.25	0.20–2.00	0.40–1.00	0.20–0.80
Zirconium	...	0.020 max	...	0.02–0.12	...	...	...	...
Boron	0.006 max	0.003–0.010	0.003–0.01	0.003–0.01	0.003–0.01	0.0008–0.006	...	0.006 max
Iron	1.8 max	1.5 max	5.00 max	2.00 max	4.00 max	5.00–9.00	...	remainder <sup>B</sup>
Copper	0.5 max	0.1 max	...	0.50 max	0.15 max	0.50 max	0.50 max	0.30 max
Nickel	remainder <sup>B</sup>	remainder <sup>B</sup>	remainder <sup>B</sup>	remainder <sup>B</sup>	remainder <sup>B</sup>	remainder <sup>B</sup>	70.00 min	50.0–55.0
Tantalum	0.2 max	0.1 max	...	...	...	...	...	...
Columbium (Niobium)	...	0.2 max	...	...	...	0.50–2.50	...	...
Tungsten	0.8 max	0.5 max	...	...	...	...	...	...
	UNS N07080 (Formerly Grade 80A)	UNS N07752	UNS N09925	UNS N07725				
Carbon	0.10 max	0.020–0.060	0.03 max	0.03 max				
Manganese	1.00 max	1.00 max	1.0 max	0.35 max				
Silicon	1.00 max	0.50 max	0.5 max	0.20 max				
Phosphorus	...	0.008 max	0.03 max	0.015 max				
Sulfur	0.015 max	0.003 max	0.03 max	0.010 max				
Chromium	18.00–21.00	14.50–17.00	19.5–22.5	19.00–22.50				
Cobalt	...	0.050 max	...	...				
Molybdenum	...	...	2.5–3.5	7.00–9.50				
Columbium (Nb) + tantalum	...	0.70–1.20	0.5 max (Nb only)	2.75–4.00				
Titanium	1.80–2.70	2.25–2.75	1.9–2.40	1.00–1.70				
Aluminum	0.50–1.80	0.40–1.00	0.1–0.5	0.35 max				
Boron	...	0.007 max	...	...				
Iron	3.00 max	5.00–9.00	22.0 min	remainder <sup>B</sup>				
Copper	...	0.50 max	1.5–3.0	...				
Zirconium	...	0.050 max	...	...				
Vanadium	...	0.10 max	...	...				
Nickel	remainder <sup>B</sup>	70.0 min	42.0–46.0	55.0–59.0				

<sup>A</sup> If determined.

<sup>B</sup> The element shall be determined arithmetically by difference.

4.1.9 *Samples for Product (Check) Analysis*—Whether samples for product (check) analysis shall be furnished (9.2).

4.1.10 *Purchaser Inspection*—If the purchaser wishes to witness tests or inspection of material at the place of manufacture, the purchase order must so state indicating which tests or inspections are to be witnessed (Section 13).

## 5. Chemical Composition

5.1 The material shall conform to the requirements as to chemical composition prescribed in Table 1.

5.2 If a product (check) analysis is performed by the purchaser, the material shall conform to the product (check) analysis variations prescribed in Specification B880.

## 6. Mechanical Properties

6.1 Unless otherwise specified, the material shall be supplied in the cold worked or solution treated condition, suitable for subsequent age hardening.

6.2 The cold worked or solution treated material shall be capable of meeting the mechanical property requirements of Table 3, and the stress rupture requirements of Table 4 (except alloys UNS N07022, N09925 and N07725), following the precipitation hardening treatment described in Table 2.

6.3 When the material is to be supplied in the cold worked or solution treated plus aged condition, the requirements of Table 3 and Table 4 (except alloys UNS N07022, N09925 and N07725) shall apply, with the precipitation hardening treatment of Table 2, or as agreed upon between the purchaser and the manufacturer as part of the purchase contract.

## 7. Dimensions and Permissible Variations

7.1 *Diameter, Thickness, or Width*—The permissible variations from the specified dimensions of cold-worked rod and bar shall be as prescribed in Table 5, and of hot-worked rod and bar as prescribed in Table 6.

TABLE 2 Heat Treatment<sup>A</sup>

Alloy	Recommended Annealing Treatment	Recommended Solution Treatment	Recommended Stabilizing Treatment	Precipitation Hardening Treatment
N07022 <sup>B</sup> Type 1A or 1B	...	1800 to 2100°F (982 to 1149°C), hold ½ h/in., 5 minutes minimum, rapid air cool or water quench	...	
N07022 <sup>C</sup> Type 2	...	1800 to 2100°F (982 to 1149°C), hold ½ h/in., 5 minutes minimum, rapid air cool or water quench	...	1125 ± 25°F (605 ± 14°C), hold 10 h, air cool <sup>B</sup>
N07022 Type 3	...	1800 to 2100°F (982 to 1149°C), hold ½ h/in., 5 minutes minimum, rapid air cool or water quench	...	1300 ± 25°F (705 ± 14°C), hold 16 h, furnace cool to 1125 ± 25°F (605 ± 14°C), hold 32 h, air cool
N07208	...	2000 to 2125°F (1093 to 1163°C), hold ½ h/in., 5 to 10 minutes minimum, water quench or rapid air cool	...	1850 ± 25°F (1010 ± 14°C), hold 2 h, air cool, followed by 1450 ± 25°F (788 ± 14°C), hold 8 h, air cool
N07252	...	1950 ± 25°F (1066 ± 14°C), hold 4 h, air cool	...	1400 ± 25°F (760 ± 14°C), hold 15 h, air cool or furnace cool
N07001	...	1825 to 1900°F (996 to 1038°C), hold 4 h, oil or water quench	1550 ± 25°F (843 ± 14°C), hold 4 h, air cool	1400 ± 25°F (760 ± 14°C), hold 16 h, air cool or furnace cool
N07500	2150 ± 25°F (1177 ± 14°C), hold 2 h, air cool (bars only)	1975 ± 25°F (1080 ± 14°C), hold 4 h, air cool	1550 ± 25°F (843 ± 14°C), hold 24 h, air cool	1400 ± 25°F (760 ± 14°C), hold 16 h, air cool or furnace cool
N07740	...	2010°F (1100°C) minimum, hold 1 h per in. of thickness with ½ h minimum hold, water quench or rapid air cool	...	1400 to 1500°F (760 to 815°C), hold 4 h minimum for up to 2 in. thickness + additional ½ h per each additional in. of thickness, air cool
N07750 Type 1 (Service above 1100°F) (593°C)	...	2100 ± 25°F (1149 ± 14°C), hold 2 to 4 h, air cool	1550 ± 25°F (843 ± 14°C), hold 24 h, air cool	1300 ± 25°F (704 ± 14°C), hold 20 h, air cool or furnace cool
N07750 Type 2 (Service up to 1100°F) (593°C)	...	1800 ± 25°F (982 ± 14°C), hold ½ h min, cool at rate equivalent to air cool or faster	...	1350 ± 25°F (732 ± 14°C), hold 8 h, furnace cool to 1150 ± 25°F (621 ± 14°C), hold until total precipitation heat treatment has reached 18 h, air cool
N07750 Type 3	...	1975 – 2050°F (1079 – 1121°C), hold 1 to 2 h, air cool	...	1300 ± 25°F (704 ± 14°C), hold 20 h, + 4 – 0 h, air cool
N07752 Type 1	...	1975 ± 25°F (1080 ± 14°C), hold 1 to 2 h, cool by water or oil quenching	...	1320 ± 25°F (715 ± 14°C), hold 20 h, +2, –0 h, air cool
N07752 Type 2	...	1975 ± 25°F (1080 ± 14°C), hold 1 to 2 h, cool by water or oil quenching	...	1400 ± 25°F (760 ± 14°C), hold 100 h, +4, –0 h, air cool
N07718	...	1700 to 1850°F (924 to 1010°C), hold ½ h min, cool at rate equivalent to air cool or faster	...	1325 ± 25°F (718 ± 14°C), hold at temperature for 8 h, furnace cool to 1150 ± 25°F (621 ± 14°C), hold until total precipitation heat treatment time has reached 18 h, air cool

ASME BPVC.II.B-2025 Section II part B) 2025  
 Click to view the full PDF of ASME BPVC.II.B (ASME BPVC Section II part B) 2025

TABLE 2 Continued

Alloy	Recommended Annealing Treatment	Recommended Solution Treatment	Recommended Stabilizing Treatment	Precipitation Hardening Treatment
N07080	...	1950 ± 25°F (1066 ± 14°C), hold 8 h, air cool	1560 ± 25°F (849 ± 14°C), hold 24 h, air cool	1290 ± 25°F (699 ± 14°C), hold 16 h, air cool
N07725	...	1900 ± 25°F (1038 ± 14°C), hold ½ min, and 4 h max, cool at rate equivalent to air cool	...	1350 ± 25°F (732 ± 14°C), hold at temperature for 5 to 8½ h, furnace cool to 1150 ± 25°F (621 ± 14°C), hold at temperature for 5 to 8½ h, air cool or faster
N09925	...	1825 to 1875°F (996 to 1024°C), hold ½ min, and 4 h max, cool at rate equivalent to air cool or faster	...	1365 ± 25°F (740 ± 14°C), hold at temperature for 6 to 9 h, furnace cool to 1150 ± 25°F (621 ± 14°C), hold until total precipitation heat treatment time has reached 18 h, air cool or faster

<sup>A</sup> The purchaser shall designate on the purchase order or inquiry any partial stage of heat treatment required on material to be shipped.

<sup>B</sup> For solution treated + cold worked material only, when specified.

<sup>C</sup> For solution treated + cold worked + precipitation hardened material only, when specified.

7.1.1 *Out of Round*—Cold-worked and hot-worked rod, all sizes, in straight lengths, shall not be out-of-round by more than one half the total permissible variations in diameter shown in Table 5 and Table 6, except for hot-worked rod ½ in. (12.7 mm) and under, which may be out-of-round by the total permissible variations in diameter shown in Table 6.

7.1.2 *Corners*—Cold-worked bar shall have practically exact angles and sharp corners.

7.1.3 *Cut Lengths*—A specified length to which all rod and bar will be cut with a permissible variation of + ⅛ in. (3.18 mm), –0 for sizes 8 in. (203 mm) and less in diameter or the distance between parallel surfaces. For larger sizes, the permissible variation shall be + ¼ in. (6.35 mm), –0.

7.1.4 *Straightness for Cold-Worked and Hot-Worked Rod and Bar*—The maximum curvature (depth of chord) shall not exceed 0.050 in. multiplied by the length in feet (0.04 mm multiplied by the length in centimetres). Material under ½ in. (12.7 mm) in diameter or the distance between parallel surfaces shall be reasonably straight and free of sharp bends and kinks.

7.1.5 For forgings, dimensions and tolerances shall be as specified on the order, sketch, or drawing.

7.1.6 Dimensions and tolerances for forging stock shall be as agreed upon between the purchaser and the manufacturer.

## 8. Workmanship, Finish, and Appearance

8.1 The material shall be uniform in quality and condition, smooth, commercially straight or flat, and free of injurious imperfections.

## 9. Sampling

9.1 *Lot*—Definition:

9.1.1 A lot for chemical analysis shall consist of one heat.

9.1.2 *Mechanical Properties*—A lot for tension, hardness, and stress-rupture testing shall consist of all material from the same heat, nominal diameter or thickness, or forging size, and condition (temper).

9.1.2.1 For forging stock, a lot shall consist of one heat.

9.1.2.2 Where material cannot be identified by heat, a lot shall consist of not more than 500 lb (227 kg) of material in the same size and condition (temper).

9.2 *Test Material Selection:*

9.2.1 *Chemical Analysis*—Representative samples shall be taken during pouring or subsequent processing.

9.2.1.1 *Product (Check) Analysis* shall be wholly the responsibility of the purchaser.

9.2.2 *Mechanical Properties*—Samples of the material to provide test specimens for mechanical properties shall be taken from such locations in each lot as to be representative of that lot.

## 10. Number of Tests

10.1 *Chemical Analysis*—One test per lot.

10.2 *Tension*—One test per lot.

10.3 *Hardness*—One test per lot.

10.4 *Stress-Rupture*—One test per lot.

## 11. Specimen Preparation

11.1 *Rod and Bar:*

11.1.1 Tension test specimens shall be taken from material in the final condition (temper) and tested in the direction of fabrication.

11.1.2 All rod and bar shall be tested in full cross-section size when possible. When a full cross-section size test cannot be performed, the largest possible round specimen shown in Test Methods E8/E8M shall be used. Longitudinal strip specimens shall be prepared in accordance with Test Methods E8/E8M for rectangular bar up to ½ in. (12.7 mm), inclusive, in thickness, which are too wide to be pulled full size.

11.1.3 Forging stock test specimens shall be taken from a forged-down coupon or a sample taken directly from stock.

11.2 *Forgings:*

TABLE 3 Tensile and Hardness Requirements<sup>A</sup>

Alloy	Heat Treatment	Tensile Strength, min, psi (MPa)	Yield Strength (0.2 % offset), min, psi (MPa)	Elongation in 2 in. (50 mm) or 4D, min, %	Reduction of Area, min, %	Brinell or (Rockwell C) Hardness
N07022 Type 1A	solution + cold worked	160 000 (1103)	150 000 (1034)	17	50	382 max (42 Rc max)
N07022 Type 1B	solution + cold worked	185 000 (1276)	180 000 (1240)	13	30	425 max (46 Rc max)
N07022 Type 2	solution + cold worked + precipitation harden	178 000 (1227)	160 000 (1103)	15	24	479 max (50 Rc max)
N07022 Type 3	solution + precipitation harden	145 000 (1000)	80 000 (552)	15	14	228 min (20 Rc min)
N07208	solution + precipitation harden	150 000 (1034)	90 000 (620)	20	14	250 min (24 Rc min)
N07252	solution + precipitation harden	160 000 (1100)	90 000 (620)	20	18	310 min (34 Rc min)
N07001	solution + stabilize + precipitation harden	160 000 (1100)	110 000 (760)	15 <sup>B</sup>	18 <sup>B</sup>	310 min (34 Rc min)
N07500 (rod and bar)	anneal + solution + stabilize + precipitation harden	175 000 (120)	105 000 (725)	15	15	310 min (34 Rc min)
N07740	solution + precipitation harden	150 000 (1035)	90 000 (620)	20	18	...
N07500 (forgings)	solution + stabilize + precipitation harden	170 000 (1170)	100 000 (690)	20	18	310 min (34 Rc min)
N07750 Type 1	solution at 2100°F (1149°C) + stabilize + precipitation harden	140 000 (965)	90 000 (620)	8	...	262 min (26 Rc min)
N07750 Type 2 <sup>C</sup>	solution at 1800°F (982°C) + precipitation harden	170 000 (1170)	115 000 (790)	18	18	302 to 363 (32-40 Rc)
N07750 Type 2 <sup>D</sup>	solution at 1800°F (982°C) + precipitation harden	170 000 (1170)	115 000 (790)	15 (10) <sup>E</sup>	15 (12) <sup>E</sup>	302 to 363 (32-40 Rc)
N07750 Type 3	solution anneal at 2000°F (1093°C) + precipitation harden	160 000 (1103), min 185 000 (1276), max	100 000 (689), min 130 000 (896), max	20	20	267 to 363, Bm (27-40, Rc)
N07752 Type 1	solution anneal at 1975°F (1080°C) + precipitation harden	160 000 (1103), min 185 000 (1276), max	100 000 (689), min 130 000 (896), max	20	20	267 to 363, Ba (27-40, Rc)
N07752 Type 2	solution anneal at 1975°F (1080°C) + precipitation harden	140 000 (965)	85 000 (585)	20	20	...
N07718	solution + precipitation harden	185 000 (1275)	150 000 (1034)	12 (6) <sup>E</sup>	15 (8) <sup>E</sup>	331 min (36 Rc min)
N07080	solution + stabilize + precipitation harden	135 000 (930)	90 000 (620)	20	...	...
N07725	solution + precipitation harden	150 000 (1034)	120 000 (827)	20	35	393 max (43, Rc max)
N09925 <sup>F</sup>	solution + precipitation harden	140 000 (965)	105 000 (724)	18	25	346 max (38, Rc max)
N09925 <sup>G</sup>	solution + precipitation harden	140 000 (965)	110 000 (758)	18	25	346 max (38, Rc max)

<sup>A</sup> The supplier shall demonstrate that the material will meet fully heat-treated properties after full heat treatment in accordance with Table 2.

<sup>B</sup> Forgings.

<sup>C</sup> Up to 2.50 in. (63.5 mm), exclusive.

<sup>D</sup> 2.50 to 4.00 in. (63.5 to 101.6 mm), exclusive.

<sup>E</sup> These values apply for tension specimens machined tangentially from near the center of large disk forgings over 50 in.<sup>2</sup> (3225.8 mm<sup>2</sup>) in cross section or radially from rings 3 in. (76.2 mm) or more in thickness.

<sup>F</sup> Cold worked, solution annealed and aged, 0.625 in. (15.9 mm) to 3 in. (76.2 mm), inclusive.

<sup>G</sup> Hot worked, solution annealed and aged, 1 in. (25.4 mm) or over.

11.2.1 The tension test specimen representing each lot shall be taken from a forging or from a test prolongation.

11.2.2 The axis of the specimen shall be located at any point midway between the center and the surface of solid forgings and at any point midway between the inner and outer surfaces of the wall of hollow forgings, and shall be parallel to the direction of greatest metal flow.

11.2.3 The specimens shall be the largest possible round-type shown in Test Methods E8/E8M.

11.3 Stress-rupture specimens shall be the same as tension specimens except modified as necessary for stress-rupture testing in accordance with Test Methods E139.

12. Test Methods

12.1 Determine the chemical composition and mechanical and other properties of the material as enumerated in this specification, in case of disagreement, in accordance with the following methods:

**TABLE 4 Stress-Rupture Requirements<sup>A</sup>**

Alloy	Heat Treatment	Test Temperature, °F (°C)	Stress, psi (MPa) <sup>B</sup>	Minimum Hours	Elongation in 2 in. or 50 mm (or 4D), min, %
N07208	solution + precipitation harden	1700 (927)	13 000 (89)	50	10
N07252	solution + precipitation harden	1500 (816)	30 000 (205)	100	10
N07001	solution + stabilize + precipitation harden	1500 (816)	33 000 (230)	100	5
N07500 (rod and bar)	anneal + solution + stabilize + precipitation harden	1500 (816)	38 000 (260)	100	5
N07740 <sup>A</sup>	solution + precipitation harden	1472 (800)	41 700 (288)	23	5
N07500 (forgings)	solution + stabilize + precipitation harden	1500 (816)	38 000 (260)	100	5
N07750 Type 1	solution at 2100°F (1149°C) + stabilize + precipitation harden	1350 (732)	45 000 (310)	100	5 (311 hours exceed 136)
N07718	solution + precipitation harden	1200 (649)	100 000 (690)	23	5
N07080	solution + stabilize + precipitation harden	1400 (760)	47 000 (325)	23	3.5
N09925 <sup>A</sup>	solution + precipitation harden	...	...	...	...
N07725 <sup>A</sup>	solution + precipitation harden	...	...	...	...

<sup>A</sup> The supplier shall demonstrate that the material will meet fully heat-treated properties after full heat treatment in accordance with Table 2. Stress rupture is not required for alloys N09925 and N07725.

<sup>B</sup> Test specimens meeting minimum requirements may be overloaded to produce rupture in a reasonable and practical time period.

**TABLE 5 Permissible Variations in Diameter or Distance Between Parallel Surfaces of Cold-Worked Rods and Bars**

Specified Dimension, in. (mm) <sup>A</sup>	Permissible Variations from Specified Dimension, in. (mm)	
	Plus	Minus
<b>Rods:</b>		
1/16 to 3/16 (1.59 to 4.76), excl	0	0.002 (0.051)
3/16 to 1/2 (4.76 to 12.70), excl	0	0.003 (0.076)
1/2 to 15/16 (12.70 to 23.81), incl	0.001 (0.025)	0.002 (0.051)
Over 15/16 to 1 1/16 (23.81 to 49.2), incl	0.0015 (0.038)	0.003 (0.076)
Over 1 1/16 to 2 1/2 (49.2 to 63.5), incl	0.002 (0.051)	0.004 (0.102)
<b>Bars:</b>		
1/16 to 3/16 (1.59 to 4.76), excl	0	0.002 (0.051)
3/16 to 1/2 (4.76 to 12.7), excl	0	0.003 (0.076)

<sup>A</sup> Dimensions apply to the diameter of rods, to the distance between parallel surfaces of hexagonal, octagonal, and square bar, and separately to width and thickness of rectangular bar.

**TABLE 6 Permissible Variations in Diameter or Distance Between Parallel Surfaces of Hot-Worked Rods and Bars**

Specified Dimension, in. (mm) <sup>A</sup>	Permissible Variations from Specified Dimension, in. (mm)	
	+	-
<b>Rod and bar, hot-finished:</b>		
1 (25.4) and under	0.016 (0.406)	0.016 (0.406)
Over 1 to 2 (25.4 to 50.8), incl	0.031 (0.787)	0.016 (0.406)
Over 2 to 4 (50.8 to 101.6), incl	0.047 (1.19)	0.031 (0.787)
Over 4 (101.6)	0.125 (3.18)	0.063 (1.60)
<b>Rod, hot-finished and rough-turned or ground:</b>		
Under 1 (25)	0.005 (0.13)	0.005 (0.13)
1 (25) and over	0.031 (0.79)	0

<sup>A</sup> Dimensions apply to the diameter of rods, to the distance between parallel surfaces of hexagonal, octagonal, and square bar, and separately to width and thickness of rectangular bar.

Test	ASTM Designation
Chemical Analysis	E1473
Tension	E8/E8M
Rounding Procedure	E29
Stress-rupture	E139
Hardness Conversion	E140

12.2 For purposes of determining compliance with the specified limits for requirements of the properties listed in the following table, an observed value or a calculated value shall be rounded in accordance with the rounding method of Practice E29.

Test	Rounded Unit for Observed Or Calculated Value
Chemical composition, tolerances (when expressed in decimals), and hardness	Nearest unit in the last right-hand place of figures of the specified limit. If two choices are possible, as when the digits dropped are exactly a 5 or a 5 followed only by zeros, choose the one ending in an even digit, with zero defined as an even digit.
Tensile strength and yield strength	Nearest 1000 psi (6.9 MPa)
Elongation	Nearest 1 %
Rupture life	1 h

**13. Inspection**

13.1 Inspection of the material shall be made as agreed upon between the manufacturer and the purchaser as part of the purchase contract.

**14. Rejection and Rehearing**

14.1 Material, tested by the purchaser, that fails to conform to the requirements of this specification may be rejected. Rejection should be reported to the producer or supplier promptly and in writing. In case of dissatisfaction with the results of the test, the producer or supplier may make claim for a rehearing.

**15. Certification**

15.1 A producer’s or supplier’s certification shall be furnished to the purchaser that the material was manufactured, sampled, tested, and inspected in accordance with this specification and has been found to meet the requirements. A report of the test results shall be furnished.

**16. Product Marking**

16.1 Each bundle or shipping container shall be marked with the name of the material; condition (temper); this specification number; the size; gross, tare, and net weight; consignor and consignee address; contract or order number; or such other information as may be defined in the contract or order.

**17. Keywords**

17.1 bar; billet; forging; N07001; N07022; N07208; N07080; N07252; N07500; N07740; N07718; N07725; N07750; N07752; N09925

ASME BPVC Section II part B) 2025  
 Click to view the full PDF of ASME BPVC.II.B

**SPECIFICATION FOR Ni-Fe-Cr-Mo-Cu-N LOW-CARBON ALLOYS (UNS N08925, UNS N08031, UNS N08034, UNS N08354, AND UNS N08926), AND Cr-Ni-Fe-N LOW-CARBON ALLOY (UNS R20033) BAR AND WIRE, AND Ni-Cr-Fe-Mo-N ALLOY (UNS N08936) WIRE**



**SB-649**



(25)

(Identical with ASTM Specification B649-17 except that certification has been made mandatory; and paras. 4.1.8 and 5.2 and Table 2, Footnote A have been deleted, and heat treatment requirements for UNS N08354 have been added.)

*ASME SB-649 replaces 4.1.8, 5.1 Note 1, and 5.2 of ASTM B649 and adds 5.3 as follows:*

4.1.8 DELETED

5.1 *Heat Treatment*—With the exception of UNS N08936, the material shall be supplied in the solution-treated condition except as noted in 5.2. UNS N08936 shall be supplied in the cold drawn condition.

NOTE 1—The recommended heat treatment shall consist of heating to a temperature of 2010 to 2100°F (1100 to 1150°C), followed by water quenching for UNS N08925, UNS N08031, UNS N08034, and UNS N08926, or 2010 to 2150°F (1100 to 1180°C) followed by water quenching or fast air cool for UNS R20033.

5.2 DELETED

5.3 For UNS N08354, the heat treatment shall consist of heating to a temperature of 1975°F to 2155°F (1080°C to 1180°C), followed by rapid cooling in air or water.

*ASME SB-649, Table 2 replaces Note A of ASTM B649, Table 2 with the following:*

<sup>4</sup>DELETED

*ASME SB-649 replaces 16.1 and 16.2 of ASTM B649 with the following:*

16.1 A manufacturer's certification that the material was manufactured and tested in accordance with this specification shall be furnished at the time of shipment.

16.2 A copy of the test results shall be furnished at the time of shipment.

ASMENORMDOC.COM : Click to view the full PDF of ASME BPVC.II.B (ASME BPVC Section II part B) 2025



Designation: B649 – 17

## Standard Specification for Ni-Fe-Cr-Mo-Cu-N Low-Carbon Alloys (UNS N08925, UNS N08031, UNS N08034, UNS N08354, and UNS N08926), and Cr-Ni-Fe-N Low-Carbon Alloy (UNS R20033) Bar and Wire, and Ni-Cr-Fe-Mo-N Alloy (UNS N08936) Wire<sup>1</sup>

This standard is issued under the fixed designation B649; the number immediately following the designation indicates the year of original adoption or, in the case of revision, the year of last revision. A number in parentheses indicates the year of last reapproval. A superscript epsilon ( $\epsilon$ ) indicates an editorial change since the last revision or reapproval.

### 1. Scope\*

1.1 This specification covers nickel-iron-chromium-molybdenum-copper-nitrogen alloys (UNS N08925, UNS N08031, UNS N08034, UNS N08354, and UNS N08926), and chromium-nickel-iron-nitrogen low-carbon alloy (UNS R20033) bar and wire, and nickel-chromium-iron-molybdenum-nitrogen alloy (UNS N08936) wire.

1.2 ASTM International has adopted definitions whereby some grades, such as UNS N08904,<sup>2</sup> previously in this specification were recognized as stainless steels, because those grades have iron as the largest element by mass percent. Such grades are under the oversight of ASTM Committee A01 and its subcommittees. The products of N08904 previously covered in this specification are now covered by Specifications A479/A479M and A484/A484M.

1.3 The values stated in inch-pound units are to be regarded as standard. The values given in parentheses are mathematical conversions to SI units that are provided for information only and are not considered standard.

1.4 *This standard does not purport to address all of the safety concerns, if any, associated with its use. It is the responsibility of the user of this standard to become familiar with all hazards including those identified in the appropriate Safety Data Sheet (SDS) for this product/material as provided by the manufacturer, to establish appropriate safety, health and environmental practices, and determine the applicability of regulatory limitations prior to use.*

1.5 *This international standard was developed in accordance with internationally recognized principles on standardization established in the Decision on Principles for the Development of International Standards, Guides and Recom-*

<sup>1</sup> This specification is under the jurisdiction of ASTM Committee B02 on Nonferrous Metals and Alloys and is the direct responsibility of Subcommittee B02.07 on Refined Nickel and Cobalt and Their Alloys.

Current edition approved July 1, 2017. Published August 2017. Originally approved in 1981. Last previous edition approved in 2016 as B649 – 06 (2016). DOI: 10.1520/B0649-17.

<sup>2</sup> New designation established in accordance with Practice E527 and SAE J1086, Practice for Numbering Metals and Alloys (UNS).

*mendations issued by the World Trade Organization Technical Barriers to Trade (TBT) Committee.*

### 2. Referenced Documents

#### 2.1 ASTM Standards:<sup>3</sup>

A479/A479M Specification for Stainless Steel Bars and Shapes for Use in Boilers and Other Pressure Vessels

A484/A484M Specification for General Requirements for Stainless Steel Bars, Billets, and Forgings

B880 Specification for General Requirements for Chemical Check Analysis Limits for Nickel, Nickel Alloys and Cobalt Alloys

E8 Test Methods for Tension Testing of Metallic Materials

E29 Practice for Using Significant Digits in Test Data to Determine Conformance with Specifications

E55 Practice for Sampling Wrought Nonferrous Metals and Alloys for Determination of Chemical Composition

E527 Practice for Numbering Metals and Alloys in the Unified Numbering System (UNS)

E1473 Test Methods for Chemical Analysis of Nickel, Cobalt and High-Temperature Alloys

### 3. Terminology

#### 3.1 Definitions of Terms Specific to This Standard:

3.1.1 bars, *n*—hot-finished rounds, squares, octagons, and hexagons: ¼ in. (6.35 mm) and over in diameter or size. Hot-finished flats: ¼ in. to 10 in. (254 mm) inclusive in width, ⅛ in. (3.18 mm) and over in thickness. Cold-finished rounds, squares, octagons, hexagons, and shapes: over ½ in. (12.70 mm) in diameter or size. Cold-finished flats: ⅜ in. (9.52 mm) and over in width (see 3.1.1.1) and ⅛ in. and over in thickness (see 3.1.1.2).

3.1.1.1 Discussion—Widths less than ⅜ in. (9.52 mm) and thicknesses less than ⅜ in. (4.76 mm) are described generally as flat wire.

<sup>3</sup> For referenced ASTM standards, visit the ASTM website, www.astm.org, or contact ASTM Customer Service at service@astm.org. For *Annual Book of ASTM Standards* volume information, refer to the standard's Document Summary page on the ASTM website.

3.1.1.2 *Discussion*—Thickness 1/8 in. to under 3/16 in. (3.18 mm to under 4.76 mm) can be cold-rolled strip as well as bar.

3.1.2 *wire, n*—cold-finished only: round, square, octagon, hexagon, and shape wire, 1/2 in. (12.70 mm) and under in diameter or size. Cold-finished only: flat wire, 3/16 in. to under 3/8 in. (4.76 mm to under 9.52 mm) in width, 0.010 to under 3/16 in. (0.25 to under 4.76 mm) in thickness.

**4. Ordering Information**

4.1 It is the responsibility of the purchaser to specify all requirements that are necessary for material ordered to this specification. Examples of such requirements include, but are not limited to, the following:

- 4.1.1 Quantity (weight or number of pieces),
- 4.1.2 Alloy name or UNS number,
- 4.1.3 Form (bar or wire),
- 4.1.4 Dimensions,
- 4.1.5 Finish (Section 9),
- 4.1.6 ASTM designation and year of issue,
- 4.1.7 Exceptions to the specification or special requirements, and
- 4.1.8 Certification (Section 16). State if certification is required.

**5. Materials and Manufacture**

5.1 *Heat Treatment*—With the exception of UNS N08936, the material shall be supplied in the solution-treated condition except as noted in 5.2. UNS N08936 shall be supplied in the cold drawn condition.

NOTE 1—The recommended heat treatment shall consist of heating to a temperature of 2010 to 2100°F (1100 to 1150°C) followed by water quenching for UNS N08925, UNS N08031, UNS N08034, 1975 to 2150°F (1080 to 1180°C) followed by water quenching or fast air cool for UNS N08354, and UNS N08926, or 2010 to 2150°F (1100 to 1180°C) followed by water quenching or fast air cool for UNS R20033.

5.2 The heat treatment shall be waived for forging quality material.

**6. Chemical Composition**

6.1 The material sampled in accordance with 10.2 shall conform to the requirements as to chemical composition prescribed in Table 1.

6.2 *Product Analysis*—Product analysis may be made by the purchaser to verify the identity of the finished material representing each heat or lot. Such analysis may be made by any of the commonly accepted methods that will positively identify the material.

6.2.1 If a product analysis is made, the material shall conform to the product check analysis variation per Specification B880.

**7. Mechanical and Other Requirements**

7.1 *Tensile Requirements*—The material shall conform to the requirements as to the mechanical property prescribed in Table 2.

**8. Dimensions, Weight, and Permissible Variations**

8.1 *Bar*—The material referred to as bar shall conform to the variations in dimensions prescribed in Tables 3-11 inclusive, as applicable.

8.2 *Wire*—The material referred to as wire shall conform to the permissible variations in dimensions prescribed in Tables 12-16 inclusive, as applicable.

**9. Workmanship, Finish, and Appearance**

9.1 The material shall be uniform in quality and condition, smooth, commercially straight or flat, and free of injurious defects.

9.2 Bars in the hot-finished condition may be furnished with one of the following finishes:

- 9.2.1 Scale not removed,
- 9.2.2 Pickled or descaled, or
- 9.2.3 Turned (rounds only).

9.3 Bars in the cold-finished condition may be furnished with one of the following finishes:

- 9.3.1 Cold-drawn,
- 9.3.2 Centerless ground (rounds only), or
- 9.3.3 Polished (rounds only).

9.4 Wire in the cold-finished condition may be furnished with one of the following finishes:

- 9.4.1 Cold-drawn,
- 9.4.2 Centerless ground (rounds only),
- 9.4.3 Polished (rounds only), or

**TABLE 1 Chemical Requirements**

Element	UNS N08936	UNS N08925	UNS N08031	UNS N08034	UNS N08354	UNS N08926	UNS R20033
Carbon, max	0.020	0.020	0.015	0.01	0.030	0.020	0.015
Manganese <sup>A</sup>	4.00–6.00	1.00	2.0	1.0-4.0	1.00	2.00	2.0
Phosphorus, max	0.025	0.045	0.020	0.020	0.030	0.03	0.02
Sulfur, max	0.010	0.030	0.010	0.010	0.010	0.01	0.01
Silicon, max	0.50	0.50	0.3	0.1	1.00	0.5	0.50
Nickel	33.00–35.00	24.00–26.00	30.0–32.0	33.5-35.0	34.0–36.0	24.00–26.00	30.0–33.0
Chromium	26.00–28.00	19.00–21.00	26.0–28.0	26.0-27.0	22.0–24.0	19.00–21.00	31.0–35.0
Molybdenum	5.00–6.00	6.0–7.0	6.0–7.0	6.0-7.0	7.0–8.0	6.0–7.0	0.50–2.0
Copper	0.50	0.8–1.5	1.0–1.4	0.5-1.5	...	0.5–1.5	0.30–1.20
Nitrogen	0.30–0.50	0.1–0.2	0.15–0.25	0.10-0.25	0.17–0.24	0.15–0.25	0.35–0.60
Iron	balance	balance	balance	balance	balance	balance	balance
Aluminum	...	...	...	0.3	...	...	...

<sup>A</sup> Maximum %, unless range or minimum is indicated.

**TABLE 2 Mechanical Property Requirements<sup>A</sup>**

Alloy	Cold Finished and Hot Finished Annealed, <sup>B</sup> All Sizes Except Where Noted			Forging Quality, All Sizes
	Tensile Strength, min, psi (MPa) <sup>C</sup>	Yield Strength min, psi (MPa) <sup>C</sup>	Elongation in 2 in. (50.8 mm), min, %	
UNS N08925	87 000 (600)	43 000 (300)	40	<sup>A</sup>
UNS N08031	94 000 (650)	40 000 (270)	40	<sup>A</sup>
UNS N08034	94 000 (650)	40 000 (280)	40	<sup>A</sup>
UNS N08926	94 000 (650)	43 000 (295)	35	<sup>A</sup>
UNS N08354	93 000 (640)	43 000 (295)	40	<sup>A</sup>
UNS R20033	109 000 (750)	55 000 (380)	40	<sup>A</sup>
UNS N08936				
Up to 0.063 in. (1.60 mm) dia., incl.	280 000 (1931)	240 000 (1655)	...	...
Over 0.063 in. (1.60 mm) dia.	250 000 (1724)	220 000 (1517)	...	...

<sup>A</sup> No tensile properties are required on forging quality.

<sup>B</sup> UNS N08936 shall be supplied in the cold drawn condition only.

<sup>C</sup> For cold finished and annealed wire only, tensile strength 90 000 to 120 000 psi (620 to 830 MPa).

#### 9.4.4 Pickled.

### 10. Sampling

#### 10.1 Lots for Chemical Analysis and Mechanical Testing:

10.1.1 A lot for chemical analysis shall consist of one heat.

10.1.2 A lot for testing and inspection purposes shall consist of material from one heat of the same condition (temper), finish, and cross section, and in no case more than 30 000 lb (13 600 kg) in mass.

NOTE 2—Where material cannot be identified by heat, a lot shall consist of not more than 500 lb (227 kg) of material in the same thickness and condition, except that for pieces weighing over 500 lb, only one specimen shall be taken.

#### 10.2 Sampling for Chemical Analysis:

10.2.1 A representative sample shall be taken from each heat during pouring or subsequent processing.

10.2.2 If the manufacturer determines that the material meets the chemical requirements during pouring or subsequent processing, he shall not be required to sample and analyze the finished product.

10.2.3 Product analysis, if performed, shall be wholly the responsibility of the purchaser.

#### 10.3 Sampling for Mechanical Tests:

10.3.1 A sample of the material to provide test specimens for mechanical tests shall be taken from such a location in each lot as to be representative of that lot.

10.3.2 When samples are to be taken after delivery, the purchaser of material ordered to cut lengths may request on the purchase order additional material of adequate size to provide sample coupons for inspection purposes.

### 11. Number of Tests

11.1 One chemical analysis shall be made on each lot in accordance with 10.1.1.

11.2 One tension test shall be made on each lot in accordance with 10.1.2.

11.2.1 If any specimens selected to represent any heat fail to meet any of the test requirements, the material represented by such specimens may be reheat-treated and resubmitted for test.

### 12. Specimen Preparation

12.1 Tension test specimens shall be taken from material after final heat treatment and shall be selected in the longitudinal direction. The tension test specimens shall conform to the appropriate sections of Test Methods E8.

### 13. Test Methods

13.1 The chemical composition and mechanical properties of the material as enumerated in this specification shall, in case of disagreement, be determined in accordance with the following methods:

Test	ASTM Designations
Chemical analysis	E1473 <sup>A</sup>
Tension	E8
Rounding procedure	E29
Method of sampling	E55

<sup>A</sup> Iron shall be determined arithmetically by difference.

13.2 For purposes of determining compliance with the limits in this specification, an observed value or a calculated value shall be rounded as indicated in accordance with the rounding method of Practice E29.

Requirements	Rounded Unit for Observed or Calculated Value
Chemical composition (when expressed in decimals)	nearest unit in the last right-hand place of figures of the specified limit
Tensile strength and yield strength	nearest 1000 psi (7 MPa)
Elongation	nearest 1 %

### 14. Inspection

14.1 Inspection of the material by the purchaser shall be made as agreed upon between the purchaser and the seller as part of and set forth in the purchase contract.

### 15. Rejection and Rehearing

15.1 Material that fails to conform to the requirements of this specification may be rejected. Rejection should be reported to the producer or supplier promptly and in writing. In case of dissatisfaction with the results of the test, the producer or supplier may make claim for a rehearing.

### 16. Certification

16.1 If required by the purchaser in the contract or purchase order, a manufacturer's certification that the material was manufactured and tested in accordance with this specification shall be furnished at the time of shipment.

16.2 If required by the purchaser in the contract or purchase order, a copy of the test results shall be furnished at the time of shipment.

### 17. Packaging and Package Marking

17.1 *Marking*—Each bundle or box shall be tagged properly with metal tags showing heat number, grade, condition, specification number, and size to assure proper identification.

TABLE 3 Permissible Variations in Size of Hot-Finished Round and Square Bars

	Permissible Variations from Specified Size, in. (mm)		Out-of-Round <sup>A</sup> or Out-of-Square, <sup>B</sup> in. (mm)
	Over	Under	
1/4 (6.35) to 5/16 (7.94), incl. <sup>C,D</sup>	E	E	E
Over 5/16 (7.94) to 7/16 (11.11), incl. <sup>C,D</sup>	0.006 (0.15)	0.006 (0.15)	0.009 (0.23)
Over 7/16 (11.11) to 5/8 (15.88), incl. <sup>C,D</sup>	0.007 (0.18)	0.007 (0.18)	0.010 (0.25)
Over 5/8 (15.88) to 7/8 (22.22), incl	0.008 (0.20)	0.008 (0.20)	0.012 (0.30)
Over 7/8 (22.22) to 1 (25.40), incl	0.009 (0.23)	0.009 (0.23)	0.013 (0.33)
Over 1 (25.40) to 1 1/8 (28.58), incl.	0.010 (0.25)	0.010 (0.25)	0.015 (0.38)
Over 1 1/8 (28.58) to 1 1/4 (31.75), incl	0.011 (0.28)	0.011 (0.28)	0.016 (0.41)
Over 1 1/4 (31.75) to 1 3/8 (34.92), incl	0.012 (0.30)	0.012 (0.30)	0.018 (0.46)
Over 1 3/8 (34.92) to 1 1/2 (38.10), incl	0.014 (0.36)	0.014 (0.36)	0.021 (0.53)
Over 1 1/2 (38.10) to 2 (50.80), incl	1/64 (0.40)	1/64 (0.40)	0.023 (0.58)
Over 2 (50.80) to 2 1/2 (63.50), incl	1/32 (0.79)	0	0.023 (0.58)
Over 2 1/2 (63.50) to 3 1/2 (88.90), incl	3/64 (1.19)	0	0.035 (0.89)
Over 3 1/2 (88.90) to 4 1/2 (114.30), incl	1/16 (1.59)	0	0.046 (1.17)
Over 4 1/2 (114.30) to 5 1/2 (139.70), incl	5/64 (1.98)	0	0.058 (1.47)
Over 5 1/2 (139.70) to 6 1/2 (165.10), incl	1/8 (3.18)	0	0.070 (1.78)
Over 6 1/2 (165.10) to 8 (203.20), incl	5/32 (3.97)	0	0.085 (2.18)

<sup>A</sup> Out-of-round is the difference between the maximum and minimum diameters of the bar, measured at the same cross section.

<sup>B</sup> Out-of-square section is the difference in the two dimensions at the same cross section of a square bar, each dimension being the distance between opposite faces.

<sup>C</sup> Size tolerances have not been evolved for rounds in the size range from 1/4 to 5/16 in. (6.35 to 7.94 mm), incl. Size tolerances have not been evolved for round sections in the size range from 1/4 (6.35 mm) to approximately 5/8 in. (15.88 mm) in diameter which are produced on rod mills in coils.

<sup>D</sup> Squares in this size are not produced as hot-rolled products.

<sup>E</sup> Variations in size of coiled product made on rod mills are greater than size tolerances for product made on bar mills.

TABLE 4 Permissible Variations in Size of Hot-Finished Hexagonal and Octagonal Bars

Specified Sizes Measured Between Opposite Sides, in. (mm)	Permissible Variations from Specified Size, in. (mm)		Maximum Difference in 3 Measurements for Hexagons only, in. (mm)
	Over	Under	
1/4 (6.35) to 1/2 (12.70), incl	0.007 (0.18)	0.007 (0.18)	0.011 (0.28)
Over 1/2 (12.70) to 1 (25.40), incl	0.010 (0.25)	0.010 (0.25)	0.015 (0.38)
Over 1 (25.40) to 1 1/2 (38.10), incl	0.021 (0.53)	0.021 (0.53)	0.025 (0.64)
Over 1 1/2 (38.10) to 2 (50.80), incl	1/32 (0.79)	1/32 (0.79)	1/32 (0.79)
Over 2 (50.80) to 2 1/2 (63.50), incl.	3/64 (1.19)	3/64 (1.19)	3/64 (1.19)
Over 2 1/2 (63.50) to 3 1/2 (88.90), incl	1/16 (1.59)	1/16 (1.59)	1/16 (1.59)

TABLE 5 Permissible Variations in Thickness and Width for Hot-Finished Flat Bars

Specified Width, in. (mm)	Permissible Variations in Thickness for Thicknesses Given, in. (mm)					
	1/8 (3.18) to 1/2 (12.70), incl		Over 1/2 (12.70) to 1 (25.40), incl		Over 1 (25.40) to 2 (50.80), incl	
	Over	Under	Over	Under	Over	Under
To 1 (25.40), incl	0.008 (0.20)	0.008 (0.20)	0.010 (0.25)	0.010 (0.25)	...	...
Over 1 (25.40) to 2 (50.80), incl	0.012 (0.30)	0.012 (0.30)	0.015 (0.38)	0.015 (0.38)	0.031 (0.79)	0.031 (0.79)
Over 2 (50.80) to 4 (101.60), incl	0.015 (0.38)	0.015 (0.38)	0.020 (0.51)	0.020 (0.51)	0.031 (0.79)	0.031 (0.79)
Over 4 (101.60) to 6 (152.40), incl	0.015 (0.38)	0.015 (0.38)	0.020 (0.51)	0.020 (0.51)	0.031 (0.79)	0.031 (0.79)
Over 6 (152.40) to 8 (203.20), incl	0.016 (0.41)	0.016 (0.41)	0.025 (0.64)	0.025 (0.64)	0.031 (0.79)	0.031 (0.79)
Over 8 (203.20) to 10 (254.00), incl	0.021 (0.53)	0.021 (0.53)	0.031 (0.79)	0.031 (0.79)	0.031 (0.79)	0.031 (0.79)
	Over 2 (50.80) to 4 (101.60), incl		Over 4 (101.60) to 6 (152.40), incl		Over 6 (152.40) to 8 (203.20), incl	
	Over	Under	Over	Under	Over	Under
To 1 (25.40), incl	...	...	...	...	...	...
Over 1 (25.40) to 2 (50.80), incl	...	...	...	...	...	...
Over 2 (50.80) to 4 (101.60), incl	0.062 (1.57)	0.031 (0.79)	...	...	...	...
Over 4 (101.60) to 6 (152.40), incl	0.062 (1.57)	0.031 (0.79)	0.093 (2.36)	0.062 (1.57)	...	...
Over 6 (152.40) to 8 (203.20), incl	0.062 (1.57)	0.031 (0.79)	0.093 (2.36)	0.062 (1.57)	0.125 (3.18)	0.156 (3.96)
Over 8 (203.20) to 10 (254.00), incl	0.062 (1.57)	0.031 (0.79)	0.093 (2.36)	0.062 (1.57)	0.125 (3.18)	0.156 (3.96)
Specified Width, in. (mm)	Permissible Variations in Width, in. (mm)					
	Over			Under		
To 1 (25.40), incl	0.015 (0.38)			0.015 (0.38)		
Over 1 (25.40) to 2 (50.80), incl	0.031 (0.79)			0.031 (0.79)		
Over 2 (50.80) to 4 (101.60), incl	0.062 (1.57)			0.031 (0.79)		
Over 4 (101.60) to 6 (152.40), incl	0.093 (2.36)			0.062 (1.57)		
Over 6 (152.40) to 8 (203.20), incl	0.125 (3.18)			0.156 (3.96)		
Over 8 (203.20) to 10 (254.00), incl	0.156 (3.96)			0.187 (4.75)		

17.1.1 Large diameter bars may be line marked showing heat number, grade, condition, specification number, and size at the manufacturer's discretion.

17.2 Packaging—Bars or wire shall be bundled or boxed in such a manner as to assure safe delivery to their destination when properly transported by any common carrier.

**TABLE 6 Permissible Variations in Size of Cold-Finished Round Bars**

Specified Size, in. (mm)	Permissible Variations from Specified Size, in. (mm) <sup>A,B</sup>	
	Over	Under
Over ½ (12.70) to 1 (25.40), excl	0.002 (0.05)	0.002 (0.05)
1 (25.40) to 1½ (38.10), excl	0.0025 (0.06)	0.0025 (0.06)
1½ (38.10) to 4 (101.60), incl <sup>C</sup>	0.003 (0.08)	0.003 (0.08)

<sup>A</sup> Unless otherwise specified, size tolerances are over and under as shown in the above table. When required, however, they may be specified all over and nothing under, or all under and nothing over, or any combination of over and under, if the total spread in size tolerance for a specified size is not less than the total spread shown in the table.

<sup>B</sup> When it is necessary to heat treat or heat treat and pickle after cold finishing, size tolerances are double those shown in the table.

<sup>C</sup> Cold-finished bars over 4 in. (101.60 mm) in diameter are produced; size tolerances for such bars have not been evolved.

**TABLE 7 Permissible Variations in Size of Cold-Finished Hexagonal, Octagonal, and Square Bars**

Specified Size, in. (mm)	Permissible Variations from Specified Size, in. (mm) <sup>A</sup>	
	Over	Under
Over ½ (12.70) to 1 (25.40), incl	0	0.004 (0.10)
Over 1 (25.40) to 2 (50.80), incl	0	0.006 (0.15)
Over 2 (50.80) to 3 (76.20), incl	0	0.008 (0.20)
Over 3 (76.20)	0	0.010 (0.25)

<sup>A</sup> When it is necessary to heat treat or heat treat and pickle after cold finishing, size tolerances are double those shown in the table.

## 18. Keywords

18.1 UNS N08031; UNS N08034; UNS N08925; UNS N08926; UNS N08354; UNS N08936; UNS R20033; bar; wire

**TABLE 8 Permissible Variations in Width and Thickness of Cold-Finished Flat Bars**

Width, in. (mm)	Permissible Variations in Width, over and under, in. (mm) <sup>A</sup>	
	For Thicknesses ¼ (6.35) and Under	For Thicknesses Over ¼ (6.35)
¾ (9.52) to 1 (25.40), incl	0.004 (0.10)	0.002 (0.05)
Over 1 (25.40) to 2 (50.80), incl	0.006 (0.15)	0.003 (0.08)
Over 2 (50.80) to 3 (76.20), incl	0.008 (0.20)	0.004 (0.10)
Over 3 (76.20) to 4½ (114.30), incl	0.010 (0.25)	0.005 (0.13)

Thickness, in. (mm)	Permissible Variations in Thickness, over and under, in. (mm) <sup>A</sup>	
	For Thicknesses ¼ (6.35) and Under	For Thicknesses Over ¼ (6.35)
¾ (9.52) to 1 (25.40), incl	0.002 (0.05)	0.002 (0.05)
Over 1 (25.40) to 2 (50.80), incl	0.003 (0.08)	0.003 (0.08)
Over 2 (50.80) to 3 (76.20), incl	0.004 (0.10)	0.004 (0.10)
Over 3 (76.20) to 4½ (114.30), incl <sup>B</sup>	0.005 (0.13)	0.005 (0.13)

<sup>A</sup> When it is necessary to heat treat and pickle after cold finishing, size tolerances are double those shown in the table.

<sup>B</sup> Cold-finished flat bars over 4½ in. (114.30 mm) wide or thick are produced; width and thickness tolerances for such bars have not been evolved.

**TABLE 9 Permissible Variations in Length of Hot-Finished or Cold-Finished Bars**

NOTE 1—The order should specify random lengths or specific lengths. When random lengths are ordered, the length tolerance is not less than 24 in. (609.60 mm). When specific lengths are ordered, Table 9 or Table 10 shall apply.

Specified Size of Rounds, Squares, Hexagons, and Octagons, and Widths of Flats, <sup>A</sup> in. (mm)	Permissible Variations in Length, in. (mm)			
	For Lengths Up to 12 ft (3658 mm), incl		For Lengths Over 12 ft (3658 mm) to 25 ft (7620 mm), incl	
	Over	Under	Over	Under
To 2 (50.80), incl	½ (12.70)	0	¾ (19.05)	0
Over 2 (50.80) to 4 (101.60), incl	¾ (19.05)	0	1 (25.40)	0
Over 4 (101.60) to 6 (152.40), incl	1 (25.40)	0	1¼ (31.75)	0
Over 6 (152.40) to 9 (228.60), incl	1¼ (31.75)	0	1½ (38.10)	0
Over 9 (228.60) to 12 (304.80), incl	1½ (38.10)	0	2 (50.80)	0

<sup>A</sup> The maximum width of bar flats is 10 in. (254.00 mm).

**TABLE 10 Permissible Variations in Length of Hot-Finished or Cold-Finished Bars Machine Cut After Machine Straightening**

NOTE 1—The order should specify random lengths or specific lengths. When random lengths are ordered, the length tolerance is not less than 24 in. (609.60 mm). When specific lengths are ordered, Table 9 or Table 10 shall apply.

Specified Size of Rounds, Squares, Hexagons, and Octagons, and Widths of Flats, <sup>A</sup> in. (mm)	Permissible Variations in Length, in. (mm)			
	For Lengths Up to 12 ft (3658 mm), incl		For Lengths Over 12 ft (3658 mm) to 25 ft (7620 mm), incl	
	Over	Under	Over	Under
To 3 (76.20), incl	⅛ (3.18)	0	⅜ (9.53)	0
Over 3 (76.20) to 6 (152.40), incl	¼ (6.35)	0	½ (12.70)	0
Over 6 (152.40) to 9 (228.60), incl	⅜ (9.53)	0	⅝ (15.88)	0
Over 9 (228.60) to 12 (304.80), incl	½ (12.70)	0	¾ (19.05)	0

<sup>A</sup> The maximum width of bar flats is 10 in. (254.00 mm).

**TABLE 11 Permissible Variations in Straightness of Machine Straightened Hot-Finished or Cold-Finished Bars**

Measurement is taken on the concave side of the bar with a straightedge. Unless otherwise specified, hot-finished or cold-finished bars for machining purposes are furnished machine straightened to the following tolerances:  
 Hot finished:  
 ⅛ in. (3.18 mm) in any 5 ft (1524 mm), but may not exceed ⅛ in. (3.18 mm) × (length in feet (mm))/(5 ft (1524 mm))  
 Cold finished:  
 ¼ in. (1.59 mm) in any 5 ft (1524 mm), but may not exceed ¼ in. (1.59 mm) × (length in feet (mm))/(5 ft (1524 mm))

**TABLE 12 Diameter and Out-of-Round Tolerances for Round Wire (Drawn, Polished, Centerless Ground, Centerless Ground and Polished)<sup>A,B,C</sup>**

Specified Diameter, in. (mm)	Diameter Tolerance, in. (mm)	
	Over	Under
0.5000 (12.70)	0.002 (0.05)	0.002 (0.05)
Under 0.5000 (12.70) to 0.3125 (7.94), incl	0.0015 (0.04)	0.0015 (0.04)
Under 0.3125 (7.94) to 0.0440 (1.12), incl	0.001 (0.03)	0.001 (0.03)
Under 0.0440 (1.12) to 0.0330 (0.84), incl.	0.0008 (0.02)	0.0008 (0.02)
Under 0.0330 (0.84) to 0.0240 (0.61), incl.	0.0005 (0.013)	0.0005 (0.013)
Under 0.0240 (0.61) to 0.0120 (0.30), incl.	0.0004 (0.010)	0.0004 (0.010)
Under 0.0120 (0.30) to 0.0080 (0.20), incl.	0.0003 (0.008)	0.0003 (0.008)
Under 0.0080 (0.20) to 0.0048 (0.12), incl.	0.0002 (0.005)	0.0002 (0.005)
Under 0.0048 (0.12) to 0.0030 (0.08), incl.	0.0001 (0.003)	0.0001 (0.003)

<sup>A</sup> Diameter tolerances are over and under as given in this table. Also, round wire can be produced to tolerances all over and nothing under, or all under and nothing over, or any combination over and under, if the total spread in diameter tolerances for a specified diameter is not less than the total spread given in this table.

<sup>B</sup> The maximum out-of-round tolerance for round wire is one half of the total size tolerance given in this table.

<sup>C</sup> When it is necessary to heat treat after cold finishing because of special mechanical property requirements, tolerances are commonly double those shown.

**TABLE 13 Size Tolerances for Drawn Wire in Hexagons, Octagons, and Squares**

Specified Size, <sup>A</sup> in. (mm)	Size Tolerance, in. (mm)	
	Over	Under
½ (12.70)	0	0.004 (0.10)
Under ½ (12.70) to ⅜ (9.53), incl	0	0.003 (0.08)
Under ⅜ (9.53) to ¼ (6.35), incl	0	0.002 (0.05)

<sup>A</sup> Distance across flats.

**TABLE 14 Length Tolerances for Round and Shape, Straightened and Cut Wire, Exact Length Resheared Wire**

Diameter, in. (mm)	Length, ft (mm)	Tolerance, in. (mm)	
		Over	Under
0.125 (3.18) and under	Up to 12 (3658), incl	¼ in. (6.35)	0
0.125 (3.18) and under	Over 12 (3658)	⅛ (3.18)	0
Over 0.125 (3.18) to 0.500 (12.70), incl	Under 3 (914)	⅜ (9.53)	0
Over 0.125 (3.18) to 0.500 (12.70), incl	3 (914) to 12 (3658), incl	¼ in. (6.35)	0
Over 0.125 (3.18) to 0.500 (12.70), incl	Over 12 (3658)	⅛ (3.18)	0

**TABLE 15 Size Tolerances for Wire for Which the Final Operation is a Surface Treatment for the Purpose of Removing Scale or Drawing Lubricant**

Specified Size, in. (mm)	Tolerance, in. (mm)	
	Over	Under
1/2 (12.70)	0.004 (0.10)	0.004 (0.10)
Under 1/2 (12.70) to 5/16 (7.94), incl	0.003 (0.08)	0.003 (0.08)
Under 5/16 (7.94) to 0.044 (1.12), incl	0.002 (0.05)	0.002 (0.05)
Under 0.044 (1.12) to 0.033 (0.84), incl	0.0013 (0.03)	0.0013 (0.03)
Under 0.033 (0.84) to 0.024 (0.61), incl	0.0008 (0.02)	0.0008 (0.02)

**TABLE 16 Thickness and Width Tolerances for Cold-Finished Flat Wire**

Specified Width, in. (mm)	Thickness Tolerance, in. (mm), over or under, for Given Thicknesses, in. (mm)			Width Tolerance, in. (mm)	
	Under	0.029 (0.74) to 0.035 (0.89), excl	0.035 (0.89) to 3/16 (4.76), excl	Over	Under
Under 3/16 (9.52) to 1/16 (1.59), incl	0.001 (0.03)	0.0015 (0.04)	0.002 (0.05)	0.005 (0.13)	0.005 (0.13)

### SUMMARY OF CHANGES

Committee B02 has identified the location of selected changes to this standard since the last issue (B649-06(2016)) that may impact the use of this standard. (Approved July 1, 2017.)

- (1) Added UNS N08034 to title of specification.
- (2) Added new alloy UNS N08034 to scope (Section 1).
- (3) Added heat treatment data to Section 5.1 Note 1 for UNS N08034.
- (4) Added chemistry data for UNS N08034 to Table 1; includes removing "max" after Manganese and replacing with Footnote A.
- (5) Added Mechanical property data to Table 2 for UNS N08034 including Footnote A for "forging quality."
- (6) Added UNS N08034 to Keywords in Section 18.

*ASTM International takes no position respecting the validity of any patent rights asserted in connection with any item mentioned in this standard. Users of this standard are expressly advised that determination of the validity of any such patent rights, and the risk of infringement of such rights, are entirely their own responsibility.*

*This standard is subject to revision at any time by the responsible technical committee and must be reviewed every five years and if not revised, either reapproved or withdrawn. Your comments are invited either for revision of this standard or for additional standards and should be addressed to ASTM International Headquarters. Your comments will receive careful consideration at a meeting of the responsible technical committee, which you may attend. If you feel that your comments have not received a fair hearing you should make your views known to the ASTM Committee on Standards, at the address shown below.*

*This standard is copyrighted by ASTM International, 100 Barr Harbor Drive, PO Box C700, West Conshohocken, PA 19428-2959, United States. Individual reprints (single or multiple copies) of this standard may be obtained by contacting ASTM at the above address or at 610-832-9585 (phone), 610-832-9555 (fax), or service@astm.org (e-mail); or through the ASTM website (www.astm.org). Permission rights to photocopy the standard may also be secured from the Copyright Clearance Center, 222 Rosewood Drive, Danvers, MA 01923, Tel: (978) 646-2600; http://www.copyright.com/*

ASMENORMDOC.COM : Click to view the full PDF of ASME BPVC.II.B (ASME BPVC Section II part B) 2025

INTENTIONALLY LEFT BLANK

# SPECIFICATION FOR SEAMLESS AND WELDED ZIRCONIUM AND ZIRCONIUM ALLOY WELDING FITTINGS



**SB-653/SB-653M**

(Identical with ASTM Specification B653/B653M-11(2020) except for the addition of para. 6.2.3 and Supplementary Requirement S4.)

ASME NORMDOC.COM : Click to view the full PDF of ASME BPVC.II.B (ASME BPVC Section II part B) 2025

# Specification for Seamless and Welded Zirconium and Zirconium Alloy Welding Fittings

## 1. Scope

1.1 This specification covers fittings, factory made from three grades of zirconium and zirconium alloys. The term welding fittings applies to butt-welding parts such as 45 and 90° elbows, 180° returns, caps, tees, reducers, lap-joint stub ends, and other types.

1.2 The values stated in either inch-pound units or SI units are to be regarded separately as the standard. Within the text, the SI units are shown in brackets. The values stated in each system are not exact equivalents; therefore, each system must be used independently of the other. Combining values from the two systems may result in nonconformance with the specification.

1.3 *This standard does not purport to address all of the safety concerns, if any, associated with its use. It is the responsibility of the user of this standard to establish appropriate safety, health, and environmental practices and determine the applicability of regulatory limitations prior to use.*

1.4 *This international standard was developed in accordance with internationally recognized principles on standardization established in the Decision on Principles for the Development of International Standards, Guides and Recommendations issued by the World Trade Organization Technical Barriers to Trade (TBT) Committee.*

## 2. Referenced Documents

### 2.1 ASTM Standards:

B493 Specification for Zirconium and Zirconium Alloy Forgings

B523/B523M Specification for Seamless and Welded Zirconium and Zirconium Alloy Tubes

B550/B550M Specification for Zirconium and Zirconium Alloy Bar and Wire

B551/B551M Specification for Zirconium and Zirconium Alloy Strip, Sheet, and Plate

B614 Practice for Descaling and Cleaning Zirconium and Zirconium Alloy Surfaces

B658/B658M Specification for Seamless and Welded Zirconium and Zirconium Alloy Pipe

### 2.2 ANSI Standards:

B16.9 Wrought Steel Butt-Welding Fittings

B36.19 Stainless Steel Pipe

2.3 *Manufacturers' Standardization Society of the Valve and Fittings Industry Standards*

SP-25 Standard Marking System for Valves, Fittings, Flanges, and Unions

SP-43 Standard Practice for Light Weight Stainless Steel Fittings

### 2.4 American Society of Mechanical Engineers:

ASME Boiler and Pressure Vessel Code, Sections VIII and IX

## 3. Terminology

### 3.1 Lot Definitions:

3.1.1 *weld fittings, n*—definition is to be mutually agreed upon between manufacturer and the purchaser.

## 4. Classification

4.1 The fittings are furnished in three grades as follows:

4.1.1 *Grade R60702 (PZ 2)*—Unalloyed zirconium.

4.1.2 *Grade R60704 (PZ 4)*—Zirconium-tin.

4.1.3 *Grade R60705 (PZ 5)*—Zirconium-niobium.

## 5. Ordering Information

5.1 Orders for materials under this specification shall include the following information:

5.1.1 Quantity,

- 5.1.2 Name of material (zirconium fittings),  
 5.1.3 Grade number (see 4.1),  
 5.1.4 ASTM designation and year of issue,  
 5.1.5 Hydrostatic test requirements (see 10.2),  
 5.1.6 Inspection requirements (see 11.1),  
 5.1.7 Finish (see Section 9), and  
 5.1.8 Additions to the specification and supplementary requirements, if required.

NOTE 1—A typical ordering description is as follows: 15 pieces, zirconium, 4-in. [100 mm], Schedule 40, 90° long radius elbows, descaled, ASTM B653 – 01, Grade R60702. Supplementary Requirement S3, Stress Relief Heat Treatment.

## 6. Materials and Manufacture

6.1 Forging, forming, or shaping operations may be performed by hammering, pressing, piercing, extruding, upsetting, rolling, bending, fusion welding, machining, or by a combination of these operations. The forming procedure shall be so applied that it will not produce injurious defects in the fittings.

6.2 Fittings containing welded seams or other joints made by welding shall comply with the following provisions:

6.2.1 Welded by welders, welding operators, and welding procedures qualified under the provisions of Section IX of the ASME Boiler and Pressure Vessel Code.

6.2.2 Filler metal, when used, shall be the same grade as the base metal.

6.2.3 Supplementary Requirement S4 is mandatory.

6.2.4 All welds on grade R60705 shall be stress relief annealed within 14 days after welding to prevent delayed hydride cracking, in accordance with Supplementary Requirements Section S3, Stress Relief Heat Treatment.

## 7. Chemical Composition

7.1 The material shall conform to the requirements as to chemical composition prescribed in Table 1.

## 8. Tensile Requirements

8.1 The material shall conform to the requirements as to the tensile properties prescribed in Table 1.

## 9. Workmanship, Finish, and Appearance

9.1 For fittings covered by ANSI B16.9 or MSS SP-43, or for fittings to be used with pipe ordered to ANSI B36.19, the sizes, shapes, and dimensions of the fittings shall be as specified in those standards.

9.2 The fittings shall be free of injurious external and internal imperfections of a nature that will interfere with the purpose for which the fittings are intended. Minor defects may

be removed by grinding, providing the wall thickness is not decreased to less than the minimum thickness, and further provided that the ground-out area shall be faired out.

## 10. Hydrostatic Tests

10.1 All fittings shall be capable of withstanding without failure, leakage, or impairment of their serviceability, a test pressure prescribed in the applicable standards in Table 1 for the pipe or tubing with which the fitting is planned to be used.

10.2 Hydrostatic tests shall be performed when required by the purchase order.

## 11. Inspection

11.1 The manufacturer shall inspect the material covered by this specification prior to shipment. If so specified in the purchase order, the purchaser or his representative may witness the testing and inspection of the material at the place of manufacture. In such cases, the purchaser shall state in his purchase order which tests he desires to witness. The manufacturer shall give ample notice to the purchaser as to the time and place of the designated tests. If the purchaser's representative does not present himself at the time agreed upon for the testing, the manufacturer shall consider the requirement for the purchaser's inspection at the place of manufacture to be waived.

11.2 The manufacturer shall afford the inspector representing the purchaser, without charge, all reasonable facilities to satisfy him that the material is being furnished in accordance with this specification. This inspection shall be so conducted as not to interfere unnecessarily with the operation of the works.

## 12. Rejection

12.1 Rejection for failure of the material to meet the requirements of this specification shall be reported to the manufacturer. Unless otherwise specified, rejected material may be returned to the manufacturer at the manufacturer's expense, unless the purchaser receives, within three weeks of the notice of rejection, other instructions for disposition.

## 13. Certification

13.1 A producer or supplier shall furnish the purchaser with a certificate that the material was manufactured, sampled, tested, and inspected in accordance with this specification and has been found to meet the requirements. The certificate shall include a report of the test results.

TABLE 1 Permissible Raw Materials

Grade <sup>a</sup>	Product and ASTM Designation				
	Pipe	Tube	Plate	Bar	Forging
PZ 2 (R60702)	B658/B658M Grade R60702	B523/B523M Grade R60702	B551/B551M Grade R60702	B550/B550M Grade R60702	B493 Grade R60702
PZ 4 (R60704)	B658/B658M Grade R60704	B523/B523M Grade R60704	B551/B551M Grade R60704	B550/B550M Grade R60704	B493 Grade R60704
PZ 5 (R60705)	B658/B658M Grade R60705	B523/B523M Grade R60705	B551/B551M Grade R60705	B550/B550M Grade R60705	B493 Grade R60705

<sup>a</sup> When fittings are of welded construction, the symbol shown shall be supplemented by the letter "W."

13.2 All material incorporated within the fitting shall be identified and shall be in accordance with the applicable standards in Table 1.

#### 14. Referee

14.1 In the event of disagreement between the manufacturer and the purchaser on the conformance of the material to the requirements of this specification or any special test specified by the purchaser, a mutually acceptable referee shall perform the tests in question. The results of the referee's testing shall be used in determining conformance of the material to this specification.

#### 15. Product Marking

15.1 Unless otherwise specified, the manufacturer's name or trademark, the schedule number, material, and size shall be stamped (see Note 2), stenciled, electroetched, or otherwise suitably marked on each fitting. In addition, each fitting shall

be marked with the identification grade symbol and suffix for the respective specification listed in Table 1. On wall thicknesses thinner than Schedule 40S, no stamps or other indented markings shall be used. When the size does not permit complete marking, identification marks may be omitted in the sequence shown in MSS SP-25.

NOTE 2—When steel stamps are used, they should be applied prior to heat treatment and care should be taken so that the marking is not deep enough to cause cracks or to reduce the wall thickness of the fitting below the minimum allowed.

#### 16. Packaging and Package Marking

16.1 The fittings shall be packaged suitably in such a manner as to assure safe delivery to its destination when properly transported by common carrier.

#### 17. Keywords

17.1 fitting; pipe; zirconium; zirconium alloy

### SUPPLEMENTARY REQUIREMENTS

Supplementary requirements shall not be considered unless specified in the order, in which event the test shall be made by the manufacturer at the purchaser's expense.

#### S1. Surface Inspection

S1.1 Liquid penetrant inspection may be performed on all outside-diameter surfaces of the fittings and inside-diameter surfaces where practicable. Acceptance shall be in accordance with Appendix 8, Section VIII of the ASME Boiler and Pressure Vessel Code.

#### S2. Radiographic Inspections of Welds

S2.1 Radiographic inspection may be performed on all weldments of the fittings in accordance with paragraph UW-51, Section VIII, of the ASME Boiler and Pressure Vessel Code.

#### S3. Stress-Relief Heat Treatment

S3.1 The stress-relieving treatment shall consist of holding the fitting at a minimum temperature of 1100°F [600°C] for not less than 30 min per inch [25 mm] of the maximum thickness in a nonreducing atmosphere.

S3.2 The minimum time at this temperature is 15 min. All stress-relieved parts shall be cleaned subsequently and shall be free of oxide scale contamination (see Practice B614).

#### S4. Fittings Manufactured for ASME Construction

S4.1 All fittings welded with filler metal intended for applications under the rules of Section VIII, Division 1 of the ASME Boiler and Pressure Vessel Code shall conform to the following: Manufacturer of such products are limited to manufacturers holding the appropriate ASME Certificate of Authorization and Code Certification Mark. In addition to conforming to this specification, the manufacturer shall meet all applicable requirements of Section VIII, Division 1 of the Code. The materials used to fabricate the fitting shall conform to ASME SB Specifications. The product shall be subject to all applicable requirements of Section VIII, Division 1 of the Code, including welding, heat treatment, nondestructive examination, authorized inspections at point of manufacture, and application of the Code Certification Mark.

The applicable ASME Partial Data Report Form signed by an Authorized Inspector and a certified mill test report shall be furnished for each lot of fittings. The term "lot" applies to all fittings of the same mill heat of material, size, and wall thickness, which are heat treated, if applicable, in one furnace charge. Each fitting shall be marked in such a manner to identify each such piece with the "lot" and the certified mill test report.

# SPECIFICATION FOR SEAMLESS AND WELDED ZIRCONIUM AND ZIRCONIUM ALLOY PIPE



**SB-658/SB-658M**

(Identical with ASTM Specification B658/B658M-11(2020) except for the addition of para. 6.2.3 and Supplementary Requirement S1.)

ASMENORMDOC.COM : Click to view the full PDF of ASME BPVC.II.B (ASME BPVC Section II part B) 2025

# Specification for Seamless and Welded Zirconium and Zirconium Alloy Pipe

## 1. Scope

1.1 This specification covers three grades of seamless and welded zirconium pipe.

1.2 Unless a single unit is used, for example corrosion mass gain in  $\text{mg}/\text{dm}^2$ , the values stated in either inch-pound or SI units are to be regarded separately as standard. The values stated in each system are not exact equivalents; therefore each system must be used independently of the other. SI values cannot be mixed with inch-pound values.

1.3 *The following precautionary caveat pertains only to the test methods portions of this specification: This standard does not purport to address all of the safety concerns, if any, associated with its use. It is the responsibility of the user of this standard to establish appropriate safety, health, and environmental practices and determine the applicability of regulatory limitations prior to use.*

1.4 *This international standard was developed in accordance with internationally recognized principles on standardization established in the Decision on Principles for the Development of International Standards, Guides and Recommendations issued by the World Trade Organization Technical Barriers to Trade (TBT) Committee.*

## 2. Referenced Documents

### 2.1 ASTM Standards:

- B614 Practice for Descaling and Cleaning Zirconium and Zirconium Alloy Surfaces
- E8/E8M Test Methods for Tension Testing of Metallic Materials
- E29 Practice for Using Significant Digits in Test Data to Determine Conformance with Specifications
- E2626 Guide for Spectrometric Analysis of Reactive and Refractory Metals (Withdrawn 2017)

### 2.2 ANSI Standard:

- B36.19 Stainless Steel Pipe

### 2.3 ASME Standard:

- ASME Boiler and Pressure Vessel Code, Section VIII
- ASME Boiler and Pressure Vessel Code, Section IX

## 3. Terminology

### 3.1 Definitions of Terms Specific to This Standard:

3.1.1 *annealed, n*—for purposes of this specification “annealed” denotes material that exhibits a recrystallized grain structure.

### 3.2 Lot Definitions:

3.2.1 *pipe, n*—a lot shall consist of a material of the same size, shape, condition, and finish produced from the same ingot or powder blend by the same reduction schedule and the same heat treatment parameters. Unless otherwise agreed between manufacturer and purchaser, a lot shall be limited to the product of an 8 h period for final continuous anneal, or to a single furnace load for final batch anneal.

## 4. Classification

4.1 The pipe is furnished in three grades as follows:

- 4.1.1 *Grade R60702*—Unalloyed zirconium.
- 4.1.2 *Grade R60704*—Zirconium-tin alloy.
- 4.1.3 *Grade R60705*—Zirconium-niobium alloy.

## 5. Ordering Information

5.1 Orders for materials under this specification should include the following information:

- 5.1.1 Quantity (weight or total length),
- 5.1.2 Name of material (zirconium pipe),
- 5.1.3 Grade number (see 4.1),
- 5.1.4 Nominal pipe size and schedule (Table X1.1),
- 5.1.5 Lengths (random or specified cut lengths),
- 5.1.6 Method of manufacture (Section 6),
- 5.1.7 Workmanship and quality level requirements (Section 10),
- 5.1.8 ASTM designation and year of issue, and
- 5.1.9 Additions to the specification and supplementary requirements, if required. See 7.3, 14.1, 15.1, and 18.1 for additional optional requirements for the purchase order.

NOTE 1—A typical ordering description is as follows: 240-ft [70-mm] zirconium pipe, seamless, descaled 3.0-in. [75-mm] Schedule 40 by 12-ft [3-m] lengths, ASTM B658/B658M - 05, Grade R60702.

TABLE 1 Chemical Requirements<sup>A</sup>

Element	Composition, %		
	UNS Grade Designation		
	R60702	R60704	R60705
Zirconium + hafnium, min	99.2	97.5	95.5
Hafnium, max	4.5	4.5	4.5
Iron + chromium	0.2 max	0.2 to 0.4	0.2 max
Tin	...	1.0 to 2.0	...
Hydrogen, max	0.005	0.005	0.005
Nitrogen, max	0.025	0.025	0.025
Carbon, max	0.05	0.05	0.05
Niobium	...	...	2.0 to 3.0
Oxygen, max	0.16	0.18	0.18

<sup>A</sup> By agreement between the purchaser and the manufacturer, analysis may be required and limits established for elements and compounds not specified in the table of chemical compositions.

TABLE 2 Permissible Variation in Check Analysis Between Different Laboratories

Element	Permissible Variation in Product Analysis, %
Hydrogen	0.002
Nitrogen	0.01
Carbon	0.01
Hafnium	0.1
Iron + chromium	0.025
Tin	0.05
Niobium	0.05
Oxygen	0.02

TABLE 3 Tensile Requirements

	UNS Grade Designations		
	R60702	R60704	R60705
Tensile strength, min, ksi [MPa]	55 [380]	60 [415]	80 [550]
Yield strength, min, ksi [MPa]	30 [205]	35 [240]	55 [380]
Elongation in 2 in. or 50 mm, min, % <sup>A</sup>	16	14	16

<sup>A</sup> When a sub-size specimen is used, the gauge length shall be as specified in Test Methods E8/E8M for that specimen.

## 6. Materials and Manufacture

6.1 Seamless pipe shall be made from any seamless method that will yield a product meeting this specification.

6.2 Pipe containing welded seams or other joints made by welding shall comply with the following provisions:

6.2.1 Welded by welders, welding operators, and welding procedures qualified under the provisions of Section IX of the ASME Boiler and Pressure Vessel Code.

6.2.2 Filler metal, when used, shall be the same grade as the base metal.

6.2.3 Supplementary Requirement S1 is mandatory.

6.2.4 Welds in grade R60705 shall be stress relief annealed within 14 days after welding to prevent delayed hydride cracking. The heat treatment shall be as follows:

6.2.4.1 The stress-relieving treatment shall consist of holding the pipe at a minimum temperature of 1100°F [600°C] for not less than 30 min per inch [25 mm] of the maximum thickness in a nonreducing atmosphere. The minimum time at this temperature is 15 min. All stress-relieved parts shall be cleaned subsequently and shall be free of oxide scale contamination (see Practice B614).

6.3 The pipe shall be furnished in the annealed or stress-relieved condition.

## 7. Chemical Composition

7.1 The material shall conform to the requirements as to chemical composition prescribed in Table 1.

7.2 The manufacturer's ingot analysis shall be considered the chemical analysis for piping, except for hydrogen and nitrogen, which shall be determined on the finished product.

7.3 When requested by the purchaser and stated in the purchase order, a product analysis for any elements listed in Table 1 shall be made on the finished product.

7.3.1 The manufacturer's analysis shall be considered as verified if the check analysis confirms the manufacturer's reported values within the tolerances prescribed in Table 2.

## 8. Tensile Requirements

8.1 The material, as represented by the test specimens, shall conform to the tensile properties prescribed in Table 3.

## 9. Permissible Variations in Dimensions

9.1 *Diametric*—Any point (cross section) along the length of the pipe, the variations in outside diameters shall not exceed those prescribed in Table 4.

9.1.1 The tolerances on the outside diameter include ovality except as provided for in 9.1.2.

9.1.2 Thin-wall pipe usually develops significant ovality (out-of-roundness) during final annealing, straightening, or both. Thin-wall pipe is defined as having a wall thickness of 3 % or less of the outside diameter. The diameter tolerances of Table 4 are not sufficient to provide for additional ovality

**TABLE 4 Permissible Variations in Diameter<sup>A</sup>**

Nominal Outside Diameter, (NPS) <sup>B</sup> in. [mm]	Permissible Variations in Outside Diameter, in. [mm]	
	Over	Under
1/8 to 1 1/2 [3.2 to 40], incl	1/64 [.4]	1/32 [.8]
Over 1 1/2 to 4 [40 to 100], incl	1/32 [.8]	1/32 [.8]
Over 4 to 8 [100 to 200], incl	1/16 [1.6]	1/32 [.8]
Over 8 to 12 [200 to 305], incl	3/32 [2.4]	1/32 [.8]

<sup>A</sup> For seamless pipe only. Tolerances on welded pipe shall be as agreed upon between the manufacturer and the purchaser.

<sup>B</sup> NPS = nominal pipe size.

expected in thin-wall pipe and are applicable only to the mean of the extreme (maximum and minimum) outside diameter readings in any one cross section. However, for thin-wall pipe the difference in extreme outside diameter readings (ovality) in any one cross section shall not exceed 1.5 % of the specified outside diameter.

**9.2 Thickness**—The variation in thickness at any point shall not be more than  $\pm 12.5$  % of the nominal wall thickness specified.

### 9.3 Length:

9.3.1 Pipe shall be furnished in lengths as specified in the purchase order. No pipe shall be under the specified length and not more than 1/4 in. [6.4 mm] over that specified.

9.3.2 For pipe ordered to random lengths, the lengths and variations shall be agreed upon between the manufacturer and the purchaser.

**NOTE 2**—A system of standard pipe sizes approved by the American National Standards Institute as ANSI B36.19, reproduced as Table X1.1, shall apply, pending the development of similar standards for zirconium.

## 10. Workmanship, Finish, and Appearance

10.1 The finished pipe shall be reasonably straight, shall have smooth ends, free of burrs, and shall be free of cracks, seams, blisters, and other injurious imperfections in accordance with standards of acceptability agreed upon between the manufacturer and the purchaser. Minor defects may be removed provided the dimensional tolerances in accordance with Section 9 are not exceeded. Unless otherwise specified, the pipe shall be furnished free of scale.

## 11. Significance of Numerical Limits

11.1 For the purpose of determining compliance with the specified limits for requirements of the properties listed in the following table, an observed value or a calculated value shall be rounded as indicated in accordance with the rounding methods of Practice E29.

Property	Rounded Unit for Observed or Calculated Value
Chemical composition and tolerances (when expressed as decimals)	Nearest unit in the last right-hand place of figures of the specified limit
Tensile strength and yield strength	Nearest 1000 psi [10 MPa]
Elongation	Nearest 1 %

## 12. Number of Tests and Retests

12.1 One longitudinal tension test shall be made from each lot, see 13.1.

12.2 One chemistry test for hydrogen and nitrogen content shall be made from each lot of finished product, see 13.3.

12.3 A hydrostatic proof test shall be performed on each length of pipe, see 13.2.

### 12.4 Retests:

12.4.1 If any sample or specimen exhibits obvious surface contamination or improper preparation disqualifying it as a truly representative sample, it shall be discarded and a new sample or specimen substituted.

12.4.2 If the results of any tests of any lot do not conform to the requirements specified, retests shall be made on additional pipe of double the original number from the same lot, each of which shall conform to the requirements specified.

12.4.3 Retesting after failure of initial retests may be done only with the approval of the purchaser.

## 13. Test Methods

13.1 **Tension Tests**—Conduct the tension test in accordance with Test Methods E8/E8M. Determine the yield strength by the offset (0.2 %) method. Determine the tensile properties using a strain rate of 0.003 to 0.007 in./in. [mm/mm]/min through the yield strength. After the yield strength has been exceeded, the cross-head speed may be increased to approximately 0.05 in./in. [mm/mm]/min to failure.

13.2 **Hydrostatic Tests**—Prior to dimensional checks, upsetting, swaging, expanding, or other forming operations, test each pipe 1/8 in. [3.2 mm] and larger in outside diameter, and with wall thickness of 0.015 in. [0.4 mm] and over to a hydrostatic pressure sufficient to produce a fiber stress of three fourths of the minimum yield strength of the pipe, provided that the test pressure does not exceed 5000 psi [35 MPa]. Determine the test pressure as follows:

$$P = 2St/D \quad (1)$$

where:

$P$  = hydrostatic test pressure, psi [MPa],  
 $S$  = allowable fiber stress of three fourths of the minimum yield strength (Table 2), psi [MPa],  
 $t$  = average wall thickness of the pipe, in. [mm], and  
 $D$  = nominal diameter of the pipe, in. [mm].

13.3 **Chemical Tests**—Conduct the chemical analysis by the standard techniques normally used by the manufacturer. Guide E2626 may be used as a guide for chemical analysis techniques.

13.4 When specified in the purchase order, all butt welds shall be 100 % radiographed or x-rayed per ASME Code Section VIII, paragraph UW-51.

## 14. Inspection

14.1 The manufacturer shall inspect the material covered by this specification prior to shipment. If so specified in the purchase order, the purchaser or his representative may witness the testing and inspection of the material at the place of manufacture. In such cases, the purchaser shall state in his purchase order which tests he desires to witness. The manufacturer shall give ample notice to the purchaser as to the time

and place of the designated tests. If the purchaser's representative does not present himself at the time agreed upon for the testing, the manufacturer shall consider the requirement for the purchaser's inspection at the place of manufacture to be waived.

14.2 The manufacturer shall afford the inspector representing the purchaser, without charge, all reasonable facilities to satisfy him that the material is being furnished in accordance with this specification. This inspection shall be so conducted as not to interfere unnecessarily with the operation of the works.

### 15. Rejection

15.1 Rejection for failure of the material to meet the requirements of this specification shall be reported to the manufacturer. Unless otherwise specified, rejected material may be returned to the manufacturer at the manufacturer's expense, unless the purchaser receives, within three weeks of the notice of rejection, other instructions for disposition.

### 16. Certification

16.1 A producer or supplier shall furnish the purchaser with a certificate that the material was manufactured, sampled, tested, and inspected in accordance with this specification and has been found to meet the requirements. The certificate shall include a report of the test results.

### 17. Referee

17.1 In the event of disagreement between the manufacturer and the purchaser on the conformance of the material to the requirements of this specification or any special test specified by the purchaser, a mutually acceptable referee shall perform the tests in question. The results of the referee's testing shall be used in determining conformance of the material to this specification.

### 18. Product Marking

18.1 Unless otherwise specified, each length of pipe  $\frac{3}{8}$  in. [9.5 mm] nominal diameter and larger, manufactured in accordance with this specification, shall be marked legibly, either by stenciling, stamping, or rolling, with the manufacturer's private identifying mark, the ASTM designation, the grade, and heat number. On smaller than  $\frac{3}{8}$ -in. [9.5-mm] nominal diameter pipe that is bundled, the same information may be stamped legibly on a metal tag securely attached to each bundle.

### 19. Packaging and Package Marking

19.1 Pipe shall be packaged suitably in such a manner as to assure safe delivery to its destination when properly transported by common carrier.

### 20. Keywords

20.1 pipe; zirconium; zirconium alloy

## SUPPLEMENTARY REQUIREMENT

### S1. Pipe Produced for Use in ASME BPV Code Construction, Section VIII

S1.1 All pipe welded with filler metal intended for applications under the rules of the appropriate division of Section VIII of the ASME Boiler and Pressure Vessel Code shall conform to the following: Manufacturer of such products are limited to manufacturers holding the appropriate ASME Certificate of Authorization and Certification Mark. In addition to conforming to this specification, the manufacturer shall meet all applicable requirements of Section VIII. The plate used to fabricate the pipe shall conform to ASME SB-551/SB-551M. The product shall be subject to all applicable requirements of Section VIII including welding, heat treatment, nondestructive examination, authorized inspection at point of manufacture, and application of the Certification Mark. The applicable ASME Partial Data Report Form signed by an Authorized Inspector and a certified mill test report shall be furnished for each lot of pipe.

For pipe that is not heat treated or is heat treated in a continuous furnace, a lot shall consist of each 200 ft (61 m) or fraction thereof of all pipe if of the same mill heat treat and wall thickness subjected to the same heat treatment. For pipe that is heat treated in a batch-type furnace that is controlled within a 50°F range and is equipped with recording pyrometers so that the heating records are available, a lot may be defined the same as for continuous furnaces. Each length of pipe shall be marked in such a manner to identify each such piece with the "lot" and the certified mill test report.



# PRACTICE FOR IDENTIFICATION MARKING OF ALUMINUM AND MAGNESIUM PRODUCTS



**SB-666/SB-666M**



(Identical with ASTM Specification B666/B666M-15.)

ASME BPVC.II.B (ASME BPVC Section II part B) 2025  
ASMENORMDOC.COM : Click to view the full PDF of ASME BPVC.II.B (ASME BPVC Section II part B) 2025

# Practice for Identification Marking of Aluminum and Magnesium Products

## 1. Scope

1.1 This practice establishes the physical item marking requirements for identification purposes for aluminum and magnesium products. Package marking for shipment and inspection acceptance is not within the scope of this standard.

1.2 The values stated in either SI units or inch-pound units are to be regarded separately as standard. The values stated in each system may not be exact equivalents; therefore, each system shall be used independently of the other. Combining values from the two systems may result in non-conformance with the standard.

1.3 *This standard does not purport to address all of the safety concerns, if any, associated with its use. It is the responsibility of the user of this standard to establish appropriate safety and health practices and determine the applicability of regulatory limitations prior to use.*

## 2. Referenced Documents

2.1 The following documents of the issue in effect on the date of material purchase form a part of this specification to the extent referenced herein:

### 2.2 ASTM Standards:

B361 Specification for Factory-Made Wrought Aluminum and Aluminum-Alloy Welding Fittings

B404/B404M Specification for Aluminum and Aluminum-Alloy Seamless Condenser and Heat-Exchanger Tubes with Integral Fins (Withdrawn 2006)

B547/B547M Specification for Aluminum and Aluminum-Alloy Formed and Arc-Welded Round Tube

B881 Terminology Relating to Aluminum- and Magnesium-Alloy Products

### 2.3 ANSI Standards:

H35.1/H35.1(M) Alloy and Temper Designation Systems for Aluminum

### 2.4 Military Standards:

MIL-STD-409 Alloy Nomenclature and Temper Designation System for Magnesium Base Alloys

## 3. Terminology

3.1 *Definitions*—Refer to Terminology B881 for definitions of product terms used in this specification.

### 3.2 Definitions of Terms Specific to This Standard:

#### 3.2.1 Marking:

3.2.2 *spot marking*—marking the identification only once on the product.

3.2.3 *continuous marking*—recurring marking of the identification in intervals not greater than 40 in. [1000 mm] throughout the length of the product.

3.2.4 *perimeter marking*—marking continuously the identification in one or two rows adjacent to the four edges of the product.

3.2.5 *tagging*—attaching tags bearing the required identification markings to coils, bundles, or containers of items which are too small to mark or whose configuration preclude marking otherwise.

## 4. Basic Marking Requirements and Application

4.1 When this practice is required by the material specification or specified in the contract or purchase order, wrought aluminum and magnesium mill products shall be marked for identification purposes only with the following information on the product or on tags attached to the product:

4.1.1 *Name or Registered Trademark of the Company*, which performs the final processing or finishing operation such as rolling, stretching, thermal treatment, etc., prior to marketing the product;

NOTE 1—The company that performs nothing more than a simple shearing or sawing operation may be excluded from marking the product with its name.

4.1.2 *Alloy and Temper of the Product*—Designations shall be in accordance with ANSI H35.1/H35.1M for aluminum and MIL-STD-409 for magnesium;

4.1.3 *Basic Number of the Specification to which the Product was Produced*—The basic number does not include the revision indicator;

4.1.4 *Specified (Ordered) Dimensions of the Following Products:*

4.1.4.1 *Sheet and Plate*—Thickness in inches [millimetres],

4.1.4.2 *Coiled Wire and Spooled Wire*—Diameter in inches [millimetres],

4.1.4.3 *Tube:*

(1) *Straight Lengths*—Outside diameter and wall thickness, in inches [millimetres],

(2) *Coiled*—Wall thickness, in inches [millimetres],

4.1.4.4 *Pipe*—Nominal pipe size and ANSI schedule number;

4.1.5 Lot number shall be included in the product marking. The definition of lot shall be that as defined in the material specification.

4.1.6 For magnesium products, the applicable lot number shall be marked on each piece in at least one location.

4.1.7 When required by the material specification, the word “seamless” on certain tube or pipe.

NOTE 2—The requirements specified in 4.1 are minimum; marking systems that involve additional information shall be as agreed upon between the producer and the purchaser.

4.2 When this practice is required by the material specification or specified in the contract or purchase order, marking of cast aluminum products shall be in accordance with Section 6.

4.3 Product marking shall be such that it shall not rub off or be otherwise obliterated by contact arising from normal handling, exposure to the elements, shipment, and storage. The height of the characters shall be commensurate with the size of the product being marked; for example, not less than 0.375 in. [9 mm] for flat sheet and plate, not less than 0.250 in. [6 mm] for hand forgings and not less than 0.125 in. [3 mm] for tubular products. Legibility of all markings shall be such as required for ready readability and the required permanency of identification.

4.4 Product marking shall be accomplished in a manner that will not adversely affect the subsequent fabrication of the material, or produce stresses that would be deleterious to the functioning of the finished product. Marking on the product shall be with marking fluid applied by printing, stamping, or stenciling. Ghost images of the characters may remain upon the removal of marking applied. Impression stamping is considered detrimental and shall not be used except on ingot, castings, forging, and certain tube products, or when required by prior agreement between the producer and purchaser.

## 5. Marking of Wrought Aluminum and Magnesium Mill Products

5.1 When this practice is required by the material specification or specified in the contract or purchase order, wrought aluminum and magnesium mill products shall be marked as follows:

5.1.1 *Lot Number, All Products*—Spot marking the product.

5.1.2 *Coiled Sheet*—Spot marking in one or more rows near the outside end as shown in Fig. 1 [Fig. 1M].

5.1.3 *Flat Sheet and Plate:*

5.1.3.1 Flat sheet less than 0.012 in. [up through 0.30 mm] (for O temper, less than 0.020 in. [up through 0.50 mm]) in thickness—Spot marking near one end,

5.1.3.2 Plate and flat sheet 0.012 in. and over [over 0.30 mm] (for O temper, 0.020 in. and over [over 0.50 mm]) in thickness and less than 6 in. [up through 150 mm] wide—Continuous marking in one row,

5.1.3.3 Plate up through 0.375 in. [10 mm] and flat sheet 0.012 in. and over [over 0.30 mm] (for O temper, 0.020 in. and over [over 0.50 mm]) in thickness, 6 through 60 in. [over 150 through 1500 mm] in width, and 36 through 200 in. [over 1000 through 5000 mm] in length—Continuous marking in rows running the direction of rolling on 6 in. [150 mm] centers across the width on one surface as shown in Fig. 2 [Fig. 2M] and Fig. 3 [Fig. 3M]. Using the marking pattern of Fig. 2 [Fig. 2M], every third row shall contain the producer’s name or trademark and the ordered thickness. The other two rows shall each contain the alloy and temper and the specification number, and shall be staggered. Using the marking pattern of Fig. 3 [Fig. 3M], there are two alternating rows. One row shall contain the producer’s name or trademark and the ordered thickness, and the alternating row shall contain the alloy and temper and the specification number. Both the marking patterns shown in Fig. 2 [Fig. 2M] and Fig. 3 [Fig. 3M] provide the same information and either can be used.

5.1.3.4 Plate over 0.375 in. [10 mm] in thickness, flat sheet and plate over 60 in. [1500 mm] in width or over 200 in. [5000

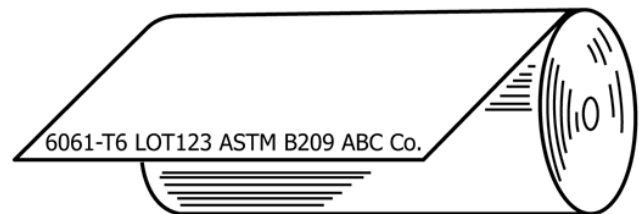
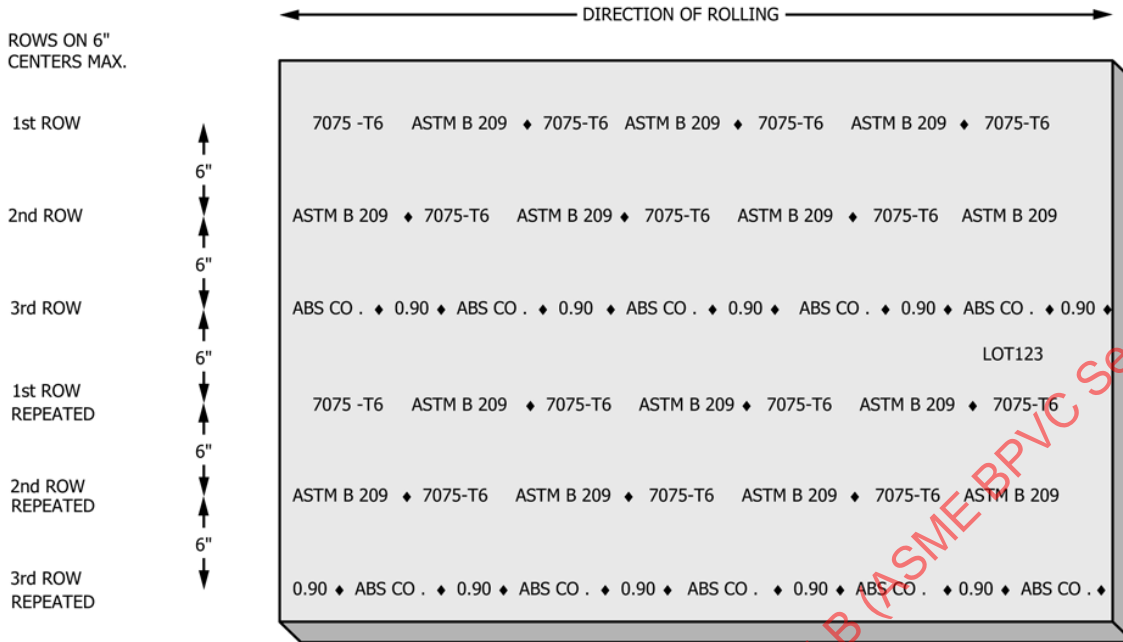

Fig. 1 Spot Marking for Coiled Sheet

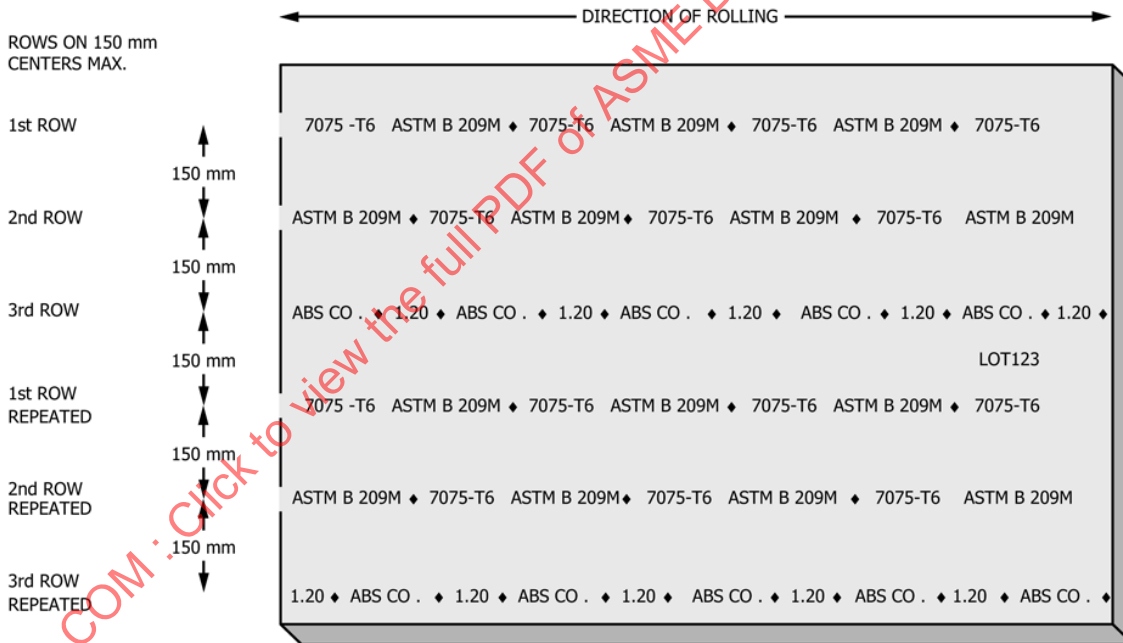

FIG. 1 M Spot Marking for Coiled Sheet



NOTE 1—Marking pattern is three staggered rows: two rows contain alloy, temper, and specification number, and every third row contains producer’s name and ordered thickness. Figure shows spot marking of the lot number.

FIG 2 Continuous Marking for Plate Through 0.375 in. and Flat Sheet 0.012 in. and over (for O Temper, 0.020 in. and over) in Thickness, 6 Through 60 in. in Width, and 36 Through 200 in. in Length



NOTE 1—Marking pattern is three staggered rows: two rows contain alloy, temper, and specification number, and every third row contains producer’s name and ordered thickness. Figure shows spot marking of the lot number.

FIG. 2 M Continuous Marking for Plate Through 10 mm and Flat Sheet over 0.30 mm (for O Temper, over 0.50 mm) in Thickness, over 150 Through 1500 mm in Width, and 1000 Through 5000 mm in Length

mm] in length—Same marking as 5.1.3.3 or perimeter marking on one surface. When perimeter marking of two rows is chosen, one row shall contain the producer’s name or trade-

mark and the ordered thickness, and the second row shall contain alloy and temper, and the specification number as shown in Fig. 4 [Fig. 4M].

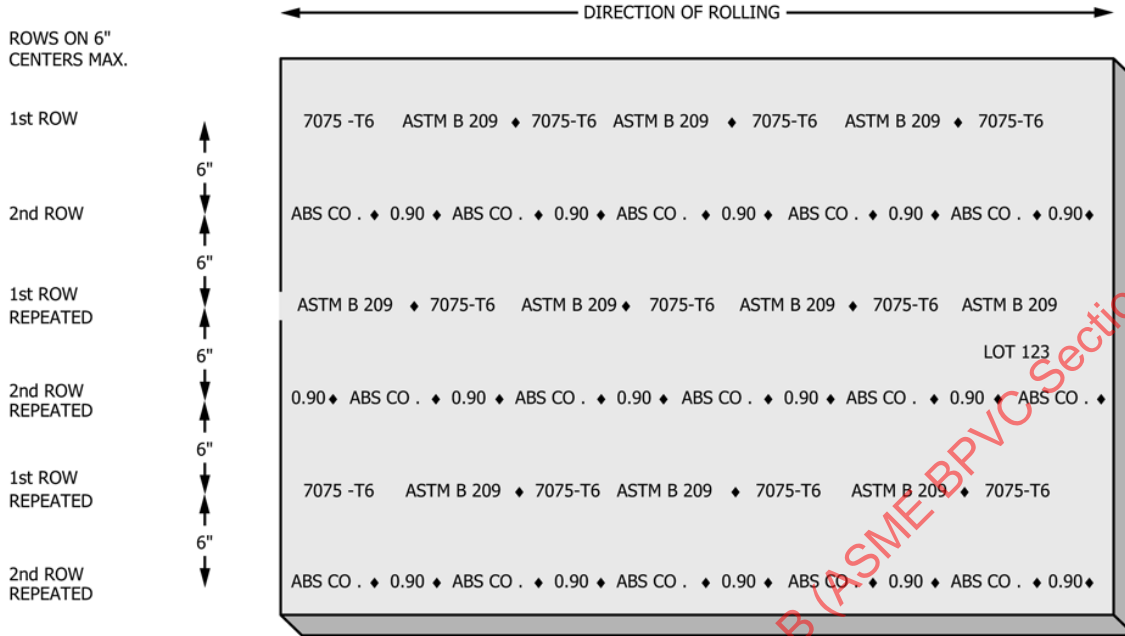

NOTE 1—Marking pattern is two alternating rows: one row contains alloy, temper, and specification number, and the alternating row contains the producer's name and ordered thickness. Figure shows spot marking of the lot number.

FIG 3 Continuous Marking for Plate Through 0.375 in. and Flat Sheet 0.012 in. and over (for O Temper, 0.020 in. and over) in Thickness, 6 Through 60 in. in Width, and 36 Through 200 in. in Length.

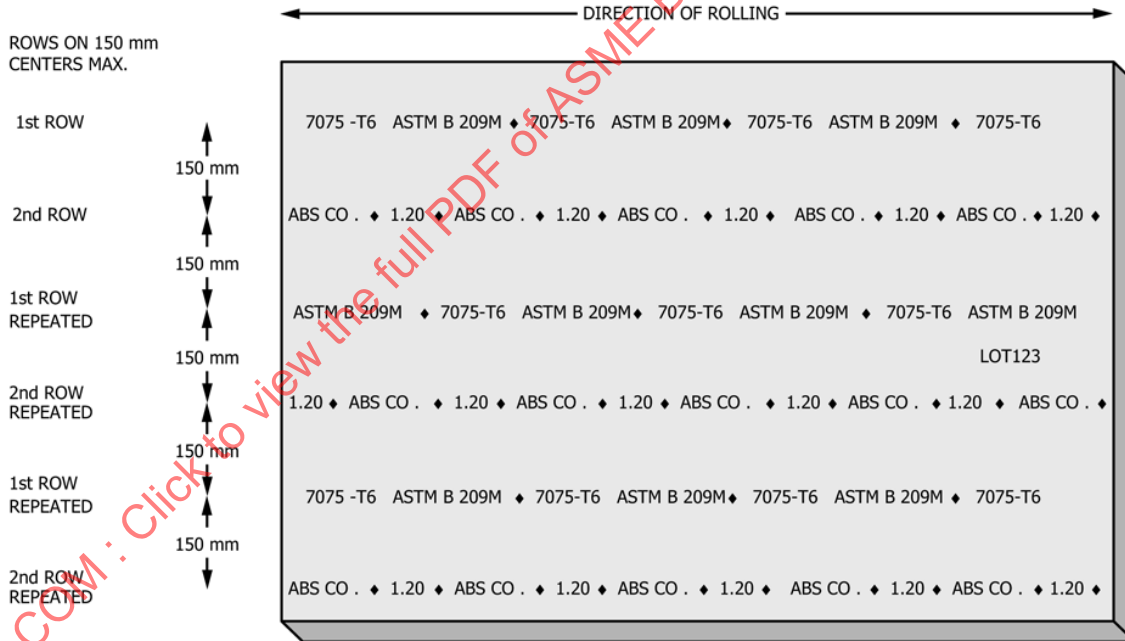

NOTE 1—Marking pattern is two alternating rows: one row contains alloy, temper, and specification number, and the alternating row contains the producer's name and ordered thickness. Figure shows spot marking of the lot number.

FIG. 3 M Continuous Marking for Plate Through 10 mm and Flat Sheet over 0.30 mm (for O Temper, over 0.50 mm) in Thickness, over 150 Through 1500 mm in Width, and 1000 Through 5000 mm in Length.

NOTE 3—If perimeter marking is applied to a full piece as produced but partial sheets or plates are supplied, an arrow shall be applied near one corner of each partial sheet or plate indicating the direction of rolling.

5.1.4 Circles:



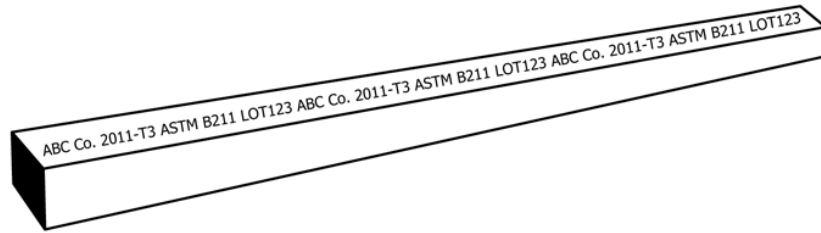

FIG 5 Continuous Marking for Rod, Bar, Profiles, and Tube in Straight Lengths

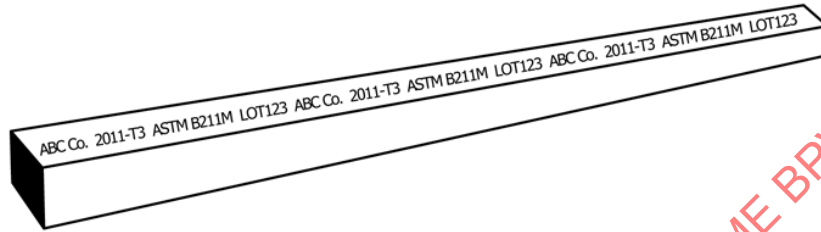

FIG. 5 M Continuous Marking for Rod, Bar, Profiles, and Tube in Straight Lengths



FIG 6 Spot Marking for Structural Profiles

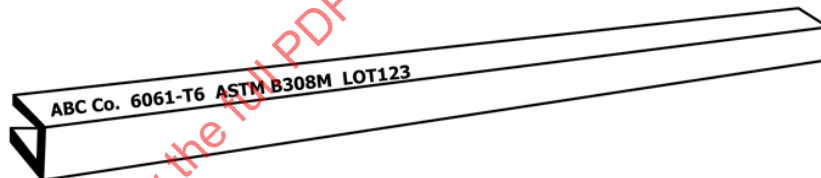

FIG. 6 M Spot Marking for Structural Profiles

## 6. Marking of Cast Aluminum Products

6.1 *Castings*—Marking shall be that as specified by the applicable material specification or as agreed upon between the producer and the purchaser.

### 6.2 *Remelt Ingot for Castings:*

6.2.1 *Marking of Aluminum Ingot*—The producer's name or trademark (see 4.1.1), alloy designation (see 4.1.2) and cast number shall be impression-stamped or otherwise permanently marked on each ingot or if strapped together, not less than four ingots in each bundle, two in the top layer and two in the bottom layer. Specification number shall not be required to be marked on this product.

6.2.2 *Marking of Magnesium Ingot*—The producer's name or trademark (see 4.1.1), alloy designation (see 4.1.2), and cast number shall be impression-stamped or otherwise permanently

marked on each ingot or bundle, if strapped together. Specification number shall not be required to be marked on this product.

6.3 *Ingot or Billet for Fabricating*—When specified in the contract or purchase order, marking shall include the producer's name or trademark, alloy and cast number. Specification data shall not be required to be marked on these products.

## 7. Marking of Unalloyed Aluminum and Magnesium Ingot

7.1 When specified in the contract or purchase order, unalloyed aluminum ingot shall be marked as follows:

7.1.1 Producer's name, logo, or trademark,

7.1.2 Production location either permanently cast in, impression stamped, or otherwise marked,

7.1.3 Metal grade or aluminum designation impression stamped or otherwise marked with legible characters, and

7.1.4 Cast number, or other identification, by convention which allows traceability of specific ingot to a specific chemical composition.

7.2 When specified in the contract or purchase order, unalloyed magnesium ingot shall be permanently marked on each ingot, pig, billet, or pallet as follows:

7.2.1 Producer's name or trademark,

7.2.2 Cast number, or other identification by convention which allows traceability of the product to a specific chemical composition.

## 8. Marking of Special Products

8.1 When specified in the contract or purchase order, marking of special products that are not covered in this

specification shall be in accordance with that specified by the applicable material specification.

8.2 Special products that are to be marked in accordance with requirements in the applicable material specification are welding fittings (Specification B361); condenser and heat exchanger tubes with integral fins (Specifications B404/B404M); and formed and arc-welded round tube (Specification B547/B547M).

## 9. Keywords

9.1 aluminum products; identification markings; magnesium products

ASMENORMDOC.COM : Click to view the full PDF of ASME BPVC.II.B (ASME BPVC Section II part B) 2025

# SPECIFICATION FOR UNS N08028 SEAMLESS TUBES



**SB-668**

(Identical with ASTM Specification B668-99 except that certification has been made mandatory.)

ASMENORMDOC.COM : Click to view the full PDF of ASME BPVC.II.B (ASME BPVC Section II part B) 2025

# SPECIFICATION FOR UNS N08028 SEAMLESS TUBES



SB-668

(Identical with ASTM Specification B 668-99 except that certification has been made mandatory.)

## 1. Scope

**1.1** This specification covers UNS N08028 seamless cold-finished tubes intended for general corrosive service. The general requirements are covered in Specification B 829.

**1.2** The values stated in inch-pound units are to be regarded as the standard. The values given in parentheses are for information only.

## 2. Referenced Documents

### 2.1 ASTM Standard:

B 829 Specification for General Requirements for Nickel and Nickel Alloy Seamless Pipe and Tube

## 3. General Requirement

**3.1** Material furnished under this specification shall conform to the applicable requirements of Specification B 829 unless otherwise provided herein.

## 4. Ordering Information

**4.1** Orders for material under this specification shall include the following information:

**4.1.1** Alloy name or UNS number,

**4.1.2** ASTM designation and year of issue,

**4.1.3 Dimensions** — Outside diameter, minimum or average wall thickness (in inches or millimetres, not gage number), and length (specific or random),

**4.1.4** Quantity (feet or metres, or number of pieces),

**4.1.5** Optional requirements,

**4.1.6 Certification** — Certification is required (Section 9),

**4.1.7 Samples for Product (Check) Analysis** — State whether samples for product (check) analysis should be furnished, and

TABLE 1  
CHEMICAL REQUIREMENTS

Element	Composition, %
Carbon, max	0.030
Silicon, max	1.0
Manganese, max	2.50
Phosphorus, max	0.030
Sulfur, max	0.030
Chromium	26.0–28.0
Nickel	30.0–34.0
Molybdenum	3.0–4.0
Copper	0.6–1.4
Iron	Remainder <sup>4</sup>

<sup>4</sup> Determined arithmetically by difference.

**4.1.8 Purchaser Inspection** — If the purchaser wishes to witness tests or inspection of material at the place of manufacture, the purchase order must so state, indicating which tests or inspections are to be witnessed.

## 5. Material and Manufacture

**5.1** Tubes shall be made by the seamless process and shall be cold finished.

**5.2** Tubes shall be furnished in the solution-annealed condition.

NOTE 1 — The recommended heat treatment shall consist of heating the material to a temperature of 1975 to 2100°F (1080 to 1150°C) with subsequent quenching in water or rapidly cooling by other means.

**5.3** The scale shall be removed by suitable means. When bright annealed, scale removal operations are not necessary.

## 6. Chemical Composition

**6.1** The material shall conform to the requirement prescribed in Table 1.

TABLE 2  
TENSILE REQUIREMENTS

Tensile Strength, min, ksi (MPa)	Yield Strength, 0.2% Offset, min, ksi (MPa)	Elongation in 2 in. (50.8 mm) or 4 <i>D</i> , min, %
73 (500)	31 (214)	40

TABLE 3  
PERMISSIBLE VARIATIONS IN OUTSIDE DIAMETER AND WALL THICKNESS

Specified Outside Diameter, in. (mm)	Wall Thickness, %					
	Outside Diameter, in. (mm)		Average		Minimum Wall	
	+	-	+	-	+	-
Up to $\frac{5}{8}$ (15.9) excl	0.005 (0.13)	0.005 (0.13)	15.0	15.0	30.0	0
$\frac{5}{8}$ to $1\frac{1}{2}$ (15.9 to 38.1), incl	0.0075 (0.19)	0.0075 (0.19)	10.0	10.0	20.0	0
Over $1\frac{1}{2}$ to $3\frac{1}{2}$ (38.1 to 88.9), incl	0.010 (0.25)	0.010 (0.25)	10.0	10.0	22.0	0
Over $3\frac{1}{2}$ to $4\frac{1}{2}$ (88.9 to 114.3), incl	0.015 (0.38)	0.015 (0.38)	10.0	10.0	22.0	0
Over $4\frac{1}{2}$ to 5 (114.3 to 127), incl	0.020 (0.51)	0.020 (0.51)	12.5	12.5	22.0	0
Over 5 to 8 (127 to 203.2) incl	0.030 (0.76)	0.030 (0.76)	12.5	12.5	25.0	0

**6.1.1** A chemical analysis shall be made on each lot of material as described in Specification B 829.

**6.2** If a product (check) analysis is performed by the purchaser, the material shall conform to Table 1 subject to the product (check) analysis variations prescribed in Specification B 829.

## 7. Mechanical and Other Requirements

**7.1** The material shall conform to the mechanical properties prescribed in Table 2. One test is required for each lot, as defined in Specification B 829.

**7.1.1** One tension test shall be made on each lot of tubes.

**7.2 Flaring Test** — One flaring test shall be made on a specimen from one end of one tube from each lot of finished tubes.

### 7.3 Hydrostatic Test or Nondestructive Test:

**7.3.1** Each tube shall be subjected to either the hydrostatic test or the nondestructive electric test at the manufacturer's option. The purchaser may specify which test is to be used.

## 8. Dimensions and Permissible Variations

**8.1 Outside Diameter and Wall Thickness** — The permissible variations in the outside diameter and wall thickness of the tube shall not exceed those prescribed in Table 3.

## 9. Certification

**9.1** A manufacturer's certification shall be furnished to the purchaser stating that the material has been manufactured, tested, and inspected in accordance with this specification, and that the test results on representative samples meet specification requirements. A report of the test results shall be furnished.

## 10. Keywords

**10.1** seamless tube; UNS N08028

ASMENORMDOC.COM : Click to view the full PDF of ASME BPVC.II.B (ASME BPVC Section II part B) 2025

INTENTIONALLY LEFT BLANK

**SPECIFICATION FOR NICKEL-IRON-CHROMIUM-  
MOLYBDENUM-COLUMBIUM STABILIZED ALLOY (UNS  
N08700) BAR AND WIRE**



**SB-672**



(Identical with ASTM Specification B672-95.)

ASMENORMDOC.COM : Click to view the full PDF of ASME BPVC.II.B (ASME BPVC Section II part B) 2025

# SPECIFICATION FOR NICKEL-IRON-CHROMIUM-MOLYBDENUM-COLUMBIUM STABILIZED ALLOY (UNS N08700) BAR AND WIRE



SB-672



(Identical with ASTM Specification B 672-95)

## 1. Scope

**1.1** This specification covers nickel-iron-chromium-molybdenum-columbium stabilized alloy (UNS N08700) bar and wire.

**1.2** The values stated in inch-pound units are to be regarded as the standard.

## 2. Referenced Documents

### 2.1 ASTM Standards

A 262 Practices for Detecting Susceptibility to Intergranular Attack in Austenitic Stainless Steels  
E 8 Test Methods for Tension Testing of Metallic Materials  
E 29 Practice for Using Significant Digits in Test Data to Determine Conformance With Specifications  
E 38 Methods for Chemical Analysis of Nickel-Chromium and Nickel-Chromium-Iron Alloys  
E 55 Practice for Sampling Wrought Nonferrous Metals and Alloys for Determination of Chemical Composition  
E 353 Test Methods for Chemical Analysis of Stainless, Heat Resisting, Maraging, and Other Similar Chromium-Nickel-Iron Alloys

## 3. Terminology

### 3.1 Descriptions of Terms Specific to This Standard

**3.1.1** The terms bar and wire as used in this specification are described as follows:

**3.1.1.1 bars** — hot-finished rounds, squares, octagons, and hexagons:  $\frac{1}{4}$  in. (6.35 mm) and over in diameter or size. Hot-finished flats:  $\frac{1}{4}$  in. to 10 in. (254 mm), inclusive, in width,  $\frac{1}{8}$  in. (3.18 mm) and over in thickness. Cold-finished rounds, squares, octagons, hexagons, and shapes: over  $\frac{1}{2}$  in. (12.7 mm) in diameter or size. Cold-finished flats:  $\frac{3}{8}$  in. (9.52 mm) and over in width (see

3.1.1.1),  $\frac{1}{8}$  in. and over in thickness (see 3.1.1.2).

(1) Widths less than 0.375 in. (9.52 mm) and thicknesses less than 0.187 in. (4.75 mm) are generally described as flat wire.

(2) Thicknesses 0.125 in. to under 0.187 in. (3.18 mm to under 4.76 mm) can be cold-rolled strip as well as bar.

**3.1.1.2 wire** — Cold-finished only: round, square, octagon, hexagon, and shape wire,  $\frac{1}{2}$  in. and under in diameter or size. Cold-finished only: flat wire,  $\frac{3}{16}$  in. (4.76 mm) to under 0.375 in. (9.52 mm) in width, 0.010 in. (0.254 mm) to under  $\frac{3}{16}$  in. thickness.

## 4. Ordering Information

**4.1** Orders for material under this specification shall include the following information:

**4.1.1** quantity (weight or number of pieces);

**4.1.2** name of material or UNS N08700;

**4.1.3** form (bar or wire);

**4.1.4** dimensions;

**4.1.5** finish;

**4.1.6** ASTM designation and year of issue;

**4.1.7 Corrosion Test**— State if intergranular corrosion test is required (Supplementary Requirements); and

**4.1.8 Certification or Test Reports**— State if certification or test reports are required (Section 14).

NOTE 1 — A typical ordering description is as follows: 200 bars, UNS N08700, 1 in. (25.4 mm) round by 10 to 14 ft (3.0 to 4.3 m), centerless ground, ASTM 672 dated \_\_\_\_\_.

## 5. Materials and Manufacture

**5.1 Heat Treatment** — The final heat treatment shall be a solution anneal. Straightening or cold finishing, or both,

TABLE 1  
CHEMICAL REQUIREMENTS

Element	Composition, %
Nickel	24.0 to 26.0
Iron	Remainder [Note (1)]
Chromium	19.0 to 23.0
Molybdenum	4.3 to 5.0
Columbium	8 × carbon to 0.40
Carbon, max	0.04
Silicon, max	1.00
Manganese, max	2.00
Phosphorus, max	0.040
Sulfur, max	0.030
Copper, max	0.50

NOTE:

(1) Determined arithmetically by difference.

TABLE 2  
PRODUCT (CHECK) ANALYSIS

Element	Tolerances Over the Max Limit or Under the Min. Limit, %
Nickel	0.20
Chromium	0.20
Molybdenum	0.10
Columbium	0.05
Carbon	0.01
Silicon	0.05
Manganese	0.04
Phosphorus	0.005
Sulfur	0.005
Copper	0.03

may be performed after the final solution annealing operation. Cold drawing to more than a minor sizing reduction (preferred maximum 5% in area) after final solution annealing is not recommended.

NOTE 2 — The recommended solution anneal consists of heating to a minimum temperature of 2,000°F (1,090°C) and cooling rapidly to room temperature.

## 6. Chemical Composition

**6.1** Heat analysis, on samples in accordance with 11.2, shall conform to the requirements as to chemical composition prescribed in Table 1.

**6.2** If a product analysis is performed by the purchaser, the material shall conform to the composition limits within the product analysis variation prescribed in Table 2.

## 7. Mechanical Requirements

**7.1** The material shall conform to the requirements as to the mechanical property prescribed in Table 3.

## 8. Dimensions and Permissible Variations

**8.1 Bar** — Bars shall conform to the variations in dimensions prescribed in Tables 4 to 12, inclusive, as applicable.

**8.2 Wire** — Wire shall conform to the permissible variations in dimensions prescribed in Tables 13 to 17, inclusive, as applicable.

## 9. Workmanship, Finish, and Appearance

**9.1** The product shall be uniform in quality and condition, smooth, commercially straight or flat, and free of injurious imperfections.

## 10. Sampling

### 10.1 Lot — Definition

**10.1.1** A lot for chemical analysis shall consist of one heat.

**10.1.2** A lot for mechanical properties or corrosion testing (Supplementary Requirement S1) shall consist of all material from a heat and cross-sectional size, heat treated by the same practice.

### 10.2 Test Material Selection

**10.2.1 Chemical Analysis** — A representative sample from each lot shall be taken during pouring or subsequent processing.

**10.2.1.1 Product (Check) Analysis** shall be wholly the responsibility of the purchaser.

**10.2.2 Mechanical Properties and Corrosion Test** (Supplementary Requirement S1) — Samples of the material to provide test specimens shall be taken from such locations in each lot as to be representative of that lot.

## 11. Number of Tests

**11.1 Chemical Analysis** — one test per lot

**11.2 Mechanical Properties and Corrosion Test** — (Supplementary Requirement S1) — one test per lot

## 12. Test Methods

**12.1** Determine the chemical composition, mechanical properties, and corrosion resistance of the material as enumerated in this specification, in case of disagreement, in accordance with the following methods:

Test	ASTM Designation
Corrosion test (Supplementary Requirement S1)	A 262, Practice C
Chemical analysis	E 38, E 353 <sup>A,B</sup>
Tension	E 8
Rounding procedure	E 29
Method of sampling for product analysis	E 55

<sup>A</sup> Iron shall be determined arithmetically by difference.

<sup>B</sup> Methods E 38 is to be used only for elements not covered in Test Methods E 353.

TABLE 3  
MECHANICAL PROPERTY REQUIREMENTS

Condition	Material Dimensions, in.	Test Direction	Tensile Strength, Min., ksi (MPa)	Yield Strength (0.2 % Offset), Min., ksi (MPa)	Elongation in 2 in. or 50.8 mm, or 4D, Min., %	Reduction of Area, Min., %
Annealed, hot-finished or cold-finished	All	Longitudinal	80 (550)	35 (240)	30.0	50.0
Annealed, hot-finished or cold-finished	Widths, 3 and over [Note (1)]	Transverse	80 (550)	35 (240)	25.0	40.0

NOTE:

(1) If the material diameter or width is over 3 in. (76.2 mm), material may be tensile tested in the transverse direction.

TABLE 4  
PERMISSIBLE VARIATIONS IN SIZE OF HOT-ROLLED ROUND AND SQUARE BARS

	Permissible Variations From Specified Size, in. (mm)		Out-of-Round [Note (1)] or Out-of-Square [Note (2)], in. (mm)
	Over	Under	
0.250 (6.35) to 0.312 (7.94) incl [Notes (3), (4)]	[Note (5)]	[Note (5)]	[Note (5)]
Over 0.312 (7.94) to 0.438 (11.11) incl [Notes (3), (4)]	0.006 (0.15)	0.006 (0.15)	0.009 (0.23)
Over 0.438 (11.11) to 0.625 (15.88) incl [Notes (3), (4)]	0.007 (0.18)	0.007 (0.18)	0.010 (0.25)
Over 0.625 (15.88) to 0.875 (22.22) incl	0.008 (0.20)	0.008 (0.20)	0.012 (0.30)
Over 0.875 (22.22) to 1.000 (25.40) incl	0.009 (0.23)	0.009 (0.23)	0.013 (0.33)
Over 1.000 (25.40) to 1.125 (28.58) incl	0.010 (0.25)	0.010 (0.25)	0.015 (0.38)
Over 1.125 (28.58) to 1.250 (31.75) incl	0.011 (0.28)	0.011 (0.28)	0.016 (0.41)
Over 1.250 (31.75) to 1.375 (34.92) incl	0.012 (0.30)	0.012 (0.30)	0.018 (0.46)
Over 1.375 (34.92) to 1.500 (38.10) incl	0.014 (0.36)	0.014 (0.36)	0.021 (0.53)
Over 1.500 (38.10) to 2.000 (50.80) incl	0.016 (0.40)	0.016 (0.40)	0.023 (0.58)
Over 2.000 (50.80) to 2.500 (63.50) incl	0.031 (0.79)	0	0.023 (0.58)
Over 2.500 (63.50) to 3.500 (88.90) incl	0.047 (1.19)	0	0.035 (0.89)
Over 3.500 (88.90) to 4.500 (114.30) incl	0.063 (1.59)	0	0.046 (1.17)
Over 4.500 (114.30) to 5.500 (139.70) incl	0.078 (1.98)	0	0.058 (1.47)
Over 5.500 (139.70) to 6.500 (165.10) incl	0.125 (3.18)	0	0.070 (1.78)
Over 6.500 (165.10) to 8.000 (203.20) incl	0.156 (3.97)	0	0.085 (2.18)

NOTES:

- (1) Out-of-round is the difference between the minimum diameters of the bar, measured at the same cross section.
- (2) Out-of-square section is the difference in the two dimensions at the same section of a square bar, each dimension being the distance between opposite faces.
- (3) Size tolerances have not been evolved for rounds in the size range of 0.250 to 0.312 in. (6.35 to 7.94 mm), inclusive. Size tolerances have not been evolved for round sections in the size range of 0.250 in. to approximately 0.625 in. (15.88 mm) in diameter which are produced on rod mills in coils.
- (4) Variations in size of coiled product made on rod mills are greater than size tolerances for product made on bar mills.
- (5) Squares in this size are not produced as hot-rolled products.

**TABLE 5**  
**PERMISSIBLE VARIATIONS IN SIZE OF HOT-ROLLED HEXAGONAL AND OCTAGONAL BARS**

Specified Sizes Measured Between Opposite Sides, in. (mm)	Permissible Variations From Specified Size, in. (mm)		Max Difference in 3 Measurements for Hexagons Only, in. (mm)
	Over	Under	
0.250 (6.35) to 0.500 (12.70) incl	0.007 (0.18)	0.007 (0.18)	0.011 (0.28)
Over 0.500 (12.70) to 1.000 (25.40) incl	0.010 (0.25)	0.010 (0.25)	0.015 (0.38)
Over 1.000 (25.40) to 1.500 (38.10) incl	0.021 (0.53)	0.021 (0.53)	0.025 (0.64)
Over 1.500 (38.10) to 2.000 (50.80) incl	0.031 (0.79)	0.031 (0.79)	0.031 (0.79)
Over 2.000 (50.80) to 2.500 (63.50) incl	0.047 (1.19)	0.047 (1.19)	0.047 (1.19)
Over 2.500 (63.50) to 3.500 (88.90) incl	0.063 (1.59)	0.063 (1.59)	0.063 (1.59)

**TABLE 6**  
**PERMISSIBLE VARIATIONS IN THICKNESS AND WIDTH FOR HOT-ROLLED FLAT BARS**

Specified Width, in. (mm)	Permissible Variations in Thickness for Thickness Given, in. (mm)					
	0.125 (3.18) to 0.500 (12.70) Incl		Over 0.500 (12.70) to 1.000 (25.40) Incl		Over 1.000 (25.40) to 2.000 (50.80) Incl	
	Over	Under	Over	Under	Over	Under
To 1.000 (25.40) incl	0.008 (0.20)	0.008 (0.20)	0.010 (0.25)	0.010 (0.25)		
Over 1.000 (25.40) to 2.000 (50.80) incl	0.012 (0.30)	0.012 (0.30)	0.015 (0.38)	0.015 (0.38)	0.031 (0.79)	0.031 (0.79)
Over 2.000 (50.80) to 4.000 (101.60) incl	0.015 (0.38)	0.015 (0.38)	0.020 (0.51)	0.020 (0.51)	0.031 (0.79)	0.031 (0.79)
Over 4.000 (101.60) to 6.000 (152.40) incl	0.015 (0.38)	0.015 (0.38)	0.020 (0.51)	0.020 (0.51)	0.031 (0.79)	0.031 (0.79)
Over 6.000 (152.40) to 8.000 (203.20) incl	0.016 (0.41)	0.016 (0.41)	0.025 (0.41)	0.025 (0.41)	0.031 (0.79)	0.031 (0.79)
Over 8.000 (203.20) to 10.000 (254.00) incl	0.021 (0.53)	0.021 (0.53)	0.031 (0.79)	0.031 (0.79)	0.031 (0.79)	0.031 (0.79)
	Over 2.000 (50.80) to 4.000 (101.60) Incl		Over 4.000 (101.60) to 5.000 (152.40) Incl		Over 6.000 (152.40) to 8.000 (203.20) Incl	
	Over	Under	Over	Under	Over	Under
To 1.000 (25.40) incl	...	...	...	...	...	...
Over 1.000 (25.40) to 2.000 (50.80) incl	...	...	...	...	...	...
Over 2.000 (50.80) to 4.000 (101.60) incl	0.062 (1.57)	0.031 (0.79)	...	...	...	...
Over 4.000 (101.60) to 6.000 (152.40) incl	0.062 (1.57)	0.031 (0.79)	0.093 (2.36)	0.062 (1.57)	...	...
Over 6.000 (152.40) to 8.000 (203.20) incl	0.062 (1.57)	0.031 (0.79)	0.093 (2.36)	0.062 (1.57)	0.125 (3.18)	0.156 (3.96)
Over 8.000 (203.20) to 10.000 (254.00) incl	0.062 (1.57)	0.031 (0.79)	0.093 (2.36)	0.062 (1.57)	0.125 (3.18)	0.156 (3.96)
Specified Width, in. (mm)	Permissible Variations in width, in. (mm)					
	Over		Under			
To 1.000 (25.40) incl	0.015 (0.38)		0.015 (0.38)			
Over 1.000 (25.40) to 2.000 (50.80) incl	0.031 (0.79)		0.031 (0.79)			
Over 2.000 (50.80) to 4.000 (101.60) incl	0.062 (1.57)		0.031 (0.79)			
Over 4.000 (101.60) to 6.000 (152.40) incl	0.093 (2.36)		0.062 (1.57)			
Over 6.000 (152.40) to 8.000 (203.20) incl	0.125 (3.18)		0.156 (3.96)			
Over 8.000 (203.20) to 10.000 (254.00) incl	0.156 (3.96)		0.187 (4.75)			

TABLE 7  
PERMISSIBLE VARIATIONS IN SIZE OF COLD-FINISHED ROUND BARS

Specified Size, in. (mm)	Permissible Variations From Specified Size, in. (mm) [Notes (1), (2)]	
	Over	Under
Over 0.500 (12.70) to 1.000 (25.40) excl	0.002 (0.05)	0.002 (0.05)
1.000 (25.40) to 1.500 (38.10) excl	0.0025 (0.06)	0.0025 (0.06)
1.500 (38.10) to 4.000 (101.60) incl [Note (3)]	0.003 (0.08)	0.003 (0.08)

## NOTES:

- (1) Unless otherwise specified, size tolerances are over and under as shown in Table 7. When required, however, they may be specified all over and nothing under, or all under and nothing over, or any combination of over and under, if the total spread in size tolerance for a specified size is not less than the total spread shown in the Table.
- (2) When it is necessary to heat treat or heat treat and pickle after cold finishing, size tolerances are double those shown in the Table.
- (3) Cold-finished bars over 4 in. (101.60 mm) in diameter are produced; size tolerances for such bars have not been evolved.

TABLE 8  
PERMISSIBLE VARIATIONS IN SIZE OF COLD-FINISHED HEXAGONAL, OCTAGONAL, AND SQUARE BARS

Specified Size, in. (mm)	Permissible Variations From Specified Size, in. (mm) [Note (1)]	
	Over	Under
Over 0.500 (12.70) to 1.000 (25.40) incl	0	0.004 (0.10)
Over 1.000 (25.40) to 2.000 (50.80) incl	0	0.006 (0.15)
Over 2.000 (50.80) to 3.000 (76.20) incl	0	0.008 (0.20)
Over 3.000 (76.20)	0	0.010 (0.25)

## NOTE:

- (1) When it is necessary to heat treat or heat treat and pickle after cold finishing, size tolerances are double those shown in the Table.

### 13. Rejection and Reheating

**13.1** Material that fails to conform to the requirements of this specification may be rejected. Rejection should be reported to the producer or supplier promptly and in writing. In case of dissatisfaction with the results of the test, the producer or supplier may make claim for a reheating.

### 14. Certification

**14.1** When specified in the purchase order or contract, a manufacturer's certification shall be furnished to the purchaser stating that material has been manufactured, tested, and inspected in accordance with this specification, and that

TABLE 9  
PERMISSIBLE VARIATIONS IN WIDTH AND THICKNESS OF COLD-FINISHED FLAT BARS

Width, in. (mm)	Permissible Variations in Width, Over and Under, in. (mm) [Note (1)]	
	For Thicknesses 0.250 (6.35) and Under	For Thickness Over 0.250 (6.35)
0.375 (9.52) to 1.000 (25.40) incl	0.004 (0.10)	0.002 (0.05)
Over 1.000 (25.40) to 2.000 (50.80) incl	0.006 (0.15)	0.003 (0.08)
Over 2.000 (50.80) to 3.000 (76.20) incl	0.008 (0.20)	0.004 (0.10)
Over 3.000 (76.20) to 4.500 (114.30) incl	0.010 (0.25)	0.005 (0.13)

Thickness, in. (mm)	Permissible Variations in Thickness, Over and Under, in. (mm) [Note (1)]
0.125 (3.18) to 1.000 (25.40) incl	0.002 (0.05)
Over 1.000 (25.40) to 2.000 (50.80) incl	0.003 (0.08)
Over 2.000 (50.80) to 3.000 (76.20) incl	0.04 (0.10)
Over 3.000 (76.20) to 4.500 (114.30) incl [Note (2)]	0.005 (0.13)

## NOTES:

- (1) When it is necessary to heat treat and pickle after cold finishing, size tolerances are double those shown in the Table.
- (2) Cold-finished flat bars over 4.500 in. (114.30 mm) wide or thick are produced; width and thickness tolerances for such bars have not been evolved.

the test results on representative samples meet specification requirements. When specified in the purchase order or contract, a report of the test results shall be furnished.

### 15. Product Marking

**15.1** Each bundle, box, or bar shall be properly tagged with metal tags showing heat number, UNS number, condition, specification number, and size to assure proper identification.

### 16. Packaging and Package Marking

**16.1** Bars or wire shall be bundled or boxed in such a manner as to assure safe delivery to their destination when properly transported by any common carrier.

### 17. Keywords

**17.1** bar; nickel-iron-chromium-molybdenum-columbium; UNS N08700; wire

TABLE 10  
PERMISSIBLE VARIATIONS IN LENGTH OF HOT-FINISHED OR COLD-FINISHED BARS

Specified Size of Rounds, Squares, Hexagons, and Octagons and Widths of Flats, in. (mm)	Permissible Variations in Length, in. (mm)			
	For Lengths Up to 12 ft (3,658 mm) Incl		For Lengths Over 12 ft (3,658 mm) to 25 ft (7,620 mm) Incl	
	Over	Under	Over	Under
To 2.000 (50.80) incl	0.500 (12.7)	0	0.750 (19.1)	0
Over 2.000 (50.80) to 4.000 (101.60) incl	0.750 (19.0)	0	1.000 (25.4)	0
Over 4.000 (101.60) to 6.000 (152.40) incl	1.000 (25.4)	0	1.250 (31.8)	0
Over 6.000 (152.40) to 9.000 (228.60) incl	1.250 (31.8)	0	1.500 (38.1)	0
Over 9.000 (228.60) to 12.000 (304.8) incl	1.500 (38.1)	0	2.000 (50.8)	0

GENERAL NOTE: The order should specify random lengths. When random lengths are ordered, the length tolerance is not less than 24 in. (609.60 mm). When specified lengths are ordered, Table 10 or Table 11 shall apply.

NOTE:

(1) The maximum width of bar flats is 10 in. (254.00 mm).

TABLE 11  
PERMISSIBLE VARIATIONS IN LENGTH OF HOT-FINISHED OR COLD-FINISHED BARS MACHINE CUT AFTER  
MACHINE STRAIGHTENING

Specified Size of Rounds, Squares, Hexagons, and Octagons and Widths of Flats, [Note (1)]	For Lengths Up to 12 ft (3,658 mm) Incl		For Lengths Over 12 (3,658 mm) to 25 ft (7,620 mm) Incl	
	Over	Under	Over	Under
	To 3.000 (76.20) incl	0.125 (3.2)	0	0.063 (4.8)
Over 3.000 (76.20) to 6.000 (152.40) incl	0.063 (4.8)	0	0.250 (6.4)	0
Over 6.000 (152.40) to 9.000 (228.60) incl	0.250 (6.4)	0	0.188 (7.9)	0
Over 9.000 (228.60) to 12.000 (304.80) incl	0.500 (12.7)	0	0.500 (12.7)	0

GENERAL NOTE: The order should specify random lengths or specific lengths. When random lengths are ordered, the length tolerance is not less than 24 in. (609.60 mm). When specific lengths are ordered, Table 10 or Table 11 shall apply.

NOTE:

(1) The maximum width of bar flats is 10 in. (254.00 mm).

TABLE 12  
PERMISSIBLE VARIATIONS IN STRAIGHTNESS OF  
MACHINE STRAIGHTENED HOT-FINISHED OR COLD-  
FINISHED BARS

Measurement is taken on the concave side of the bar with a straightedge. Unless otherwise specified, hot-finished or cold-finished bars for machining purposes are furnished machine straightened to the following tolerances:

Hot finished:

0.125 in. (3.2 mm) in any 5 ft (1,524 mm), but may not exceed  
0.125 in. x [length in feet (mm)]/[5 ft (1,524 mm)]

Cold finish:

0.063 in. (1.6 mm) in any 5 ft (1,524 mm), but may not exceed  
0.063 in. x [length in feet (mm)]/[5 ft (1,524 mm)]

## SUPPLEMENTARY REQUIREMENTS

The following supplementary requirement may be made a requirement when the purchaser specifies it to be applicable.

### S1. Intergranular Corrosion Test

**S1.1** Material shall pass an intergranular corrosion test. Specimens taken in the as-supplied condition, sensitized 1 h at 1,250°F (677°C), and tested in accordance with Practice C of Practices A 262 shall exhibit a corrosion rate equal to or less than 2.5 mils/month (165 mg/dm<sup>2</sup>·day).

ASMENORMDOC.COM : Click to view the full PDF of ASME BPVC.II.B (ASME BPVC Section II part B) 2025

# SPECIFICATION FOR UNS N08925, UNS N08354, AND UNS N08926 WELDED PIPE



**SB-673**

(Identical with ASTM Specification B673-05(2016) except that certification and test reports have been made mandatory.)

ASMENORMDOC.COM : Click to view the full PDF of ASME BPVC.II.B (ASME BPVC Section II part B) 2025

# Specification for UNS N08925, UNS N08354, and UNS N08926 Welded Pipe

## 1. Scope

1.1 This specification covers UNS N08925, UNS N08354, and UNS N08926 welded pipe for general corrosion applications.

1.2 This specification covers pipe sizes in schedules shown in Table 1.

1.3 ASTM International has adopted definitions whereby some grades, such as UNS N08904, previously in this specification were recognized as stainless steels, because those grades have iron as the largest element by mass percent. Such grades are under the oversight of ASTM Committee A01 and its subcommittees. The products of N08904 previously covered in this specification are now covered by Specification A312/A312M.

1.4 The values stated in inch-pound units are to be regarded as standard. The values given in parentheses are mathematical conversions to SI units that are provided for information only and are not considered standard.

1.5 *This standard does not purport to address all of the safety concerns, if any, associated with its use. It is the responsibility of the user of this standard to become familiar with all hazards including those identified in the appropriate Safety Data Sheet (SDS) for this product/material as provided by the manufacturer, to establish appropriate safety and health practices, and determine the applicability of regulatory limitations prior to use.*

## 2. Referenced Documents

### 2.1 ASTM Standards:

A312/A312M Specification for Seamless, Welded, and Heavily Cold Worked Austenitic Stainless Steel Pipes

B775 Specification for General Requirements for Nickel and Nickel Alloy Welded Pipe

E527 Practice for Numbering Metals and Alloys in the Unified Numbering System (UNS)

### 2.2 ANSI Standards:

B2.1 Pipe Threads

B31.10 Power Piping

B36.10 Welded and Seamless Wrought Steel Pipe

B36.19 Stainless Steel Pipe

## 3. Classification

3.1 *Class 1*—Welded, cold worked, solution treated, and nondestructively tested in accordance with 8.3.1.

3.2 *Class 2*—Welded, cold worked, solution treated, and nondestructively tested in accordance with 8.3.2.

3.3 *Class 3*—As welded, solution treated, and nondestructively tested in accordance with 8.3.1.

## 4. General Requirement

4.1 Material furnished under this specification shall conform to the applicable requirements of Specification B775 unless otherwise provided herein.

## 5. Ordering Information

5.1 Orders for material under this specification should include the following information:

5.1.1 Alloy name or UNS number,

5.1.2 *Class*,

5.1.3 *Quantity* (feet or number of lengths),

5.1.4 *Size* (nominal size or outside diameter and schedule number or average wall thickness),

5.1.5 *Length*—Specify cut length or random,

5.1.6 *Certification*—Certification and a report of test results are required,

5.1.7 *Purchaser Inspection*—State which tests or inspections are to be witnessed,

5.1.8 *Ends*—Plain ends cut and deburred will be furnished, unless otherwise specified, and

5.1.9 *Samples for Product (Check) Analysis*—State whether samples shall be furnished.

TABLE 1 Dimensions of Welded Pipe

NOTE 1—The following table is a partial reprint of Table 1 of ANSI B36.19.

NOTE 2—The decimal thicknesses listed for the respective pipe sizes represent their nominal wall dimensions.

NOTE 3—1 in. = 25.4 mm.

Nominal Pipe Size, in.	Outside Diameter		Nominal Wall Thickness, in.									
			Schedule	5S <sup>A</sup>	Schedule	10S <sup>A</sup>	Schedule	40S	Schedule	80S	Schedule	160S
1/8	0.405	10.29	...	...	0.049	1.25	0.068	1.73	0.095	2.41	...	...
1/4	0.540	13.72	...	...	0.065	1.65	0.088	2.24	0.119	3.02	...	...
3/8	0.675	17.15	...	...	0.065	1.65	0.091	2.31	0.126	3.20	...	...
1/2	0.840	21.34	0.065	1.65	0.083	2.11	0.109	2.77	0.147	3.73	0.187	4.75
3/4	1.050	26.67	0.065	1.65	0.083	2.11	0.113	2.87	0.154	3.91	0.218	5.54
1	1.315	33.40	0.065	1.65	0.109	2.77	0.133	3.38	0.179	4.46	0.250	6.35
1 1/4	1.660	42.16	0.065	1.65	0.109	2.77	0.140	3.56	0.191	4.85	0.250	6.35
1 1/2	1.900	48.26	0.065	1.65	0.109	2.77	0.145	3.68	0.200	5.08	0.281	7.14
2	2.375	60.33	0.065	1.65	0.109	2.77	0.154	3.91	0.218	5.54	0.343	8.71
2 1/2	2.875	73.03	0.083	2.11	0.120	3.05	0.203	5.16	0.276	7.01	0.375	9.52
3	3.500	88.90	0.083	2.11	0.120	3.05	0.216	5.49	0.300	7.62	0.438	11.12
3 1/2	4.000	101.60	0.083	2.11	0.120	3.05	0.226	5.74	0.318	8.08	...	...
4	4.500	114.30	0.083	2.11	0.120	3.05	0.237	6.02	0.337	8.56	0.581	13.41
5	5.563	141.30	0.109	2.77	0.134	3.40	0.258	6.55	0.375	9.52	0.625	15.88
6	6.625	168.30	0.109	2.77	0.134	3.40	0.280	7.11	0.432	10.97	0.718	18.24
8	8.625	219.07	0.109	2.77	0.148	3.76	0.322	8.18	0.500	12.70	0.906	23.01
10	10.750	273.05	0.134	3.40	0.165	4.19	0.365	9.27	0.500 <sup>B</sup>	12.70 <sup>B</sup>	1.125	28.58
12	12.75	323.85	0.156	3.96	0.180	4.57	0.375	9.52	0.500 <sup>B</sup>	12.70 <sup>B</sup>	1.312	33.32
14	14.00	355.60	0.156 <sup>C</sup>	3.96	0.188	4.78	0.375	9.52	0.500	12.70	...	...
16	16.00	406.40	0.165 <sup>C</sup>	4.19	0.188	4.78	0.375	9.52	0.500	12.70	...	...
18	18.00	457.20	0.165 <sup>C</sup>	4.19	0.188	4.78	0.375	9.52	0.500	12.70	...	...
20	20.00	508.00	0.188 <sup>C</sup>	4.78	0.218 <sup>C</sup>	5.54	0.375	9.52	0.500	12.70	...	...
22	22.00	558.80	0.188 <sup>C</sup>	4.78	0.218 <sup>C</sup>	5.54	0.375	9.52	0.500	12.70	...	...
24	24.00	609.60	0.218 <sup>C</sup>	5.54	0.250	6.35	0.375	9.52	0.500	12.70	...	...
30	30.00	762.00	0.250 <sup>C</sup>	6.35	0.312	7.92	0.375	9.52	0.500	12.70	...	...

<sup>A</sup> Schedule 5S and 10S wall thicknesses do not permit threading in accordance with ANSI B2.1.

<sup>B</sup> These do not conform to ANSI B31.10.

<sup>C</sup> These do not conform to ANSI for Welded and Seamless Wrought Steel Pipe (ANSI B36.10).

6. Materials and Manufacture

6.1 Pipe shall be made from flat-rolled alloy by an automatic welding process with no addition of filler metal. Subsequent to welding and before final solution treatment, Class 1 and Class 2 material shall be cold worked either in both weld and base metal or in weld metal only.

NOTE 1—The recommended heat treatment shall consist of heating to a temperature of 1975 to 2150°F (1080 to 1180°C) for UNS N08354, or 2010 to 2100°F (1100 to 1150°C) for UNS N08925 and UNS N08926, followed by quenching in water or rapid cooling by other means.

6.2 Pipe shall be furnished with oxide removed. When solution treatment is performed in a protective atmosphere, descaling is not necessary.

NOTE 2—Pipe produced with the addition of filler metal is available. The manufacturer must be consulted for applicable requirements.

7. Chemical Composition

7.1 The material shall conform to the requirements as to chemical composition prescribed in Table 2.

7.2 If a product (check) analysis is performed by the purchaser, the material shall conform to the product (check) analysis variations prescribed in Specification B775.

8. Mechanical Properties and Other Requirements

8.1 Tension Test—The tensile properties of the material at room temperature shall conform to those shown in Table 3.

TABLE 2 Chemical Requirements

Element	UNS N08925	UN N08354	UNS N08926
Carbon, max	0.020	0.030	0.020
Manganese, max	1.0	1.00	2.00
Phosphorus, max	0.045	0.030	0.03
Sulfur, max	0.030	0.010	0.01
Silicon, max	0.50	1.00	0.5
Nickel	24.0 to 26.0	34.0 to 36.0	24.00 to 26.00
Chromium	19.0 to 21.0	22.0 to 24.0	19.00 to 21.00
Molybdenum	6.0 to 7.0	7.0 to 8.0	6.0 to 7.0
Copper	0.8 to 1.5	...	0.5 to 1.5
Nitrogen	0.1 to 0.2	0.17 to 0.24	0.15 to 0.25
Iron <sup>A</sup>	balance	balance	balance

<sup>A</sup> Iron shall be determined arithmetically by difference.

TABLE 3 Mechanical Properties

Alloy	Temper	Tensile Strength, min, ksi(MPa)	Yield Strength, 0.2 % offset, min, ksi†(MPa)	Elongation in 2 in. or 50 mm, (or 4D), min, %
UNS N08925	solution annealed	87 (600)	43 (300)	40
UNS N08354	solution annealed	93 (640)	43 (295)	40
UNS N08926	solution annealed	94 (650)	43 (295)	35

8.1.1 One tension test shall be made on each lot of pipe.

8.2 Flattening Test—One flattening test shall be made on a specimen from one end of one pipe from each lot.

### 8.3 *Nondestructive Tests:*

8.3.1 *Class 1 and Class 3*—Each piece in each lot shall be subjected to one of the following four tests: hydrostatic, pneumatic (air underwater), eddy-current, or ultrasonic.

8.3.2 *Class 2*—Each piece in each lot shall be subjected to a leak test and an electric test as follows:

8.3.2.1 *Leak Test*—Hydrostatic or pneumatic (air underwater).

8.3.2.2 *Electric Test*—Eddy-current or ultrasonic.

8.3.3 The manufacturer shall have the option to test Class 1 or Class 2 and select the nondestructive test methods, if not specified by the purchaser.

## 9. Dimensions and Permissible Variations

9.1 The outside diameter and nominal wall thickness shall not exceed the permissible variations prescribed in Specification B775.

## 10. Keywords

10.1 UNS N08925; UNS N08354; UNS N08926; welded pipe

ASMENORMDOC.COM : Click to view the full PDF of ASME BPVC.II.B (ASME BPVC Section II part B) 2025

# SPECIFICATION FOR UNS N08925, UNS N08354, AND UNS N08926 WELDED TUBE



SB-674

(Identical with ASTM Specification B674-05 except for editorial changes in paras. 4.1 and 7.1. Certification and test reports made mandatory by reference to SB-751.)

ASMENORMDOC.COM : Click to view the full PDF of ASME BPVC.II.B (ASME BPVC Section II part B) 2025

# Standard Specification for UNS N08925, UNS N08354, and UNS N08926 Welded Tube

## 1. Scope

1.1 This specification covers UNS N08925, UNS N08354, and UNS N08926 welded tube for general corrosion applications.

1.2 This specification covers outside diameter and nominal wall tube.

1.2.1 The tube sizes covered by this specification are 1/8 to 5 in. (3.2 to 127 mm) in outside diameter and 0.015 to 0.320 in. (0.38 to 8.13 mm), inclusive, in wall thickness.

1.3 ASTM International has adopted definitions whereby some grades, such as UNS N08904, previously in this specification were recognized as stainless steels, because those grades have iron as the largest element by mass percent. Such grades are under the oversight of ASTM Committee A01 and its subcommittees. The products of N08904 previously covered in this specification are now covered by Specification A249/A249M.

1.4 The values stated in inch-pound units are to be regarded as standard. The values given in parentheses are mathematical conversions to SI units that are provided for information only and are not considered standard.

1.5 *This standard does not purport to address all of the safety concerns, if any, associated with its use. It is the responsibility of the user of this standard to become familiar with all hazards including those identified in the appropriate Material Safety Data Sheet (MSDS) for this product/material as provided by the manufacturer, to establish appropriate safety and health practices, and determine the applicability of regulatory limitations prior to use.*

## 2. Referenced Documents

2.1 *ASTM Standards:*

A249/A249M Specification for Welded Austenitic Steel Boiler, Superheater, Heat-Exchanger, and Condenser Tubes

B751 Specification for General Requirements for Nickel and Nickel Alloy Welded Tube

E527 Practice for Numbering Metals and Alloys in the Unified Numbering System (UNS)

## 3. Ordering Information

3.1 Orders for material to this specification should include the following information:

3.1.1 Quantity (feet or number of lengths),

3.1.2 UNS number,

3.1.3 Size (outside diameter, minimum or average wall thickness),

3.1.4 Length (random or specific),

3.1.5 Class, and

3.1.6 ASTM designation.

3.1.7 *Product Analysis*—State if required.

3.1.8 DELETED

3.1.9 *Purchaser Inspection*—State which tests or inspections are to be witnessed, if any (see Tables 1 and 2).

## 4. Materials and Manufacture

4.1 Tube shall be made from flat-rolled alloy by an automatic welding process with no addition of filler metal. Subsequent to welding and prior to final annealing, the material shall be cold-worked in either the weld metal only or both weld and base metal.

NOTE 1—The recommended heat treatment shall consist of heating to a temperature of 1975 to 2150°F (1080 to 1180°C) for UNS N08354 or 2010 to 2100°F (1100 to 1150°C) for UNS N08925 and UNS N08926, followed by quenching in water or rapid cooling by other means.

4.2 Tube shall be furnished with oxide removed. When bright annealing is used, descaling is not necessary.

## 5. Chemical Composition

5.1 The material shall conform to the composition limits specified in Table 1. One test is required for each lot as defined in Specification SB-751.

TABLE 1 Chemical Requirements

Element			
	UNS N08925	UNS N08354	UNS N08926
Carbon, max	0.020	0.030	0.020
Manganese, max	1.00	1.00	2.00
Phosphorus, max	0.045	0.030	0.03
Sulfur, max	0.030	0.010	0.01
Silicon, max	0.50	1.00	0.5
Nickel	24.0 to 26.0	34.0 to 36.0	24.00 to 26.00
Chromium	19.0 to 21.0	22.0 to 24.0	19.00 to 21.00
Molybdenum	6.0 to 7.0	7.0 to 8.0	6.0 to 7.0
Copper	0.8 to 1.5	...	0.5 to 1.5
Nitrogen	0.1 to 0.2	0.17 to 0.24	0.15 to 0.25
Iron	balance	balance	balance

TABLE 2 Mechanical Properties

Alloy	Temper	Tensile Strength, min, psi (MPa)	Yield Strength, 0.2 % offset, min, psi (MPa)	Elongation in 2 in. or 50 mm (or 4D), min, %
UNS N08925	solution annealed	87 (600)	43 (295)	40
UNS N08354	solution annealed	93 (640)	43 (295)	40
UNS N08926	solution annealed	94 (650)	43 (295)	35

5.2 If a product analysis is performed, it shall meet the chemistry limits prescribed in Table 1, subject to the analysis tolerances of Specification SB-751.

## 6. Mechanical and Other Properties

6.1 *Mechanical Properties*—The material shall conform to the mechanical property requirements specified in Table 2. One test is required for each lot as defined in Specification SB-751.

6.2 *Flattening Test*—A flattening test shall be made on each end of one tube per lot. Superficial ruptures resulting from surface imperfections shall not be cause for rejection.

6.3 *Flange Test*—A flange test shall be made on each end of one tube per lot.

6.4 *Nondestructive Test Requirements:*

6.4.1 *Class 1*—Each piece in each lot shall be subject to one of the following four tests: hydrostatic, pneumatic (air under-water), eddy current, or ultrasonic.

6.4.2 *Class 2*—Each piece in each lot shall be subjected to a leak test and an electric test as follows:

6.4.2.1 *Leak Test*—Hydrostatic or pneumatic (air under-water).

6.4.2.2 *Electric Test*—Eddy current or ultrasonic.

6.5 The manufacturer shall have the option to test to Class 1 or 2 and select the nondestructive test methods, if not specified by the purchaser.

## 7. General Requirements

7.1 Material furnished under this specification shall conform to the applicable requirements of the current edition of Specification SB-751 unless otherwise provided herein.

## 8. Keywords

8.1 UNS N08925; UNS N08354; UNS N08926; welded tube

ASMENORMDOC.COM : Click to view the full PDF of ASME BPVC.II.B (ASME BPVC Section II part B) 2025

INTENTIONALLY LEFT BLANK

## SPECIFICATION FOR UNS N08367 WELDED PIPE



SB-675

(Identical with ASTM Specification B675-02(2013) except certification is mandatory.)

ASMENORMDOC.COM : Click to view the full PDF of ASME BPVC.II.B (ASME BPVC Section II part B) 2025

# SPECIFICATION FOR UNS N08367 WELDED PIPE



SB-675

[Identical with ASTM Specification B 675-02(2013) except certification is mandatory.]

## 1. Scope

**1.1** This specification covers UNS N08367 welded pipe for general corrosion applications.

**1.2** Specification B 775 lists the dimensions of welded stainless steel pipe as shown in ANSI B36.19. Pipe having other dimensions may be furnished provided such pipe complies with all other requirements of this specification.

**1.3** The values stated in inch-pound units are to be regarded as the standard. The values given in parentheses are for information only.

**1.4** *This standard does not purport to address all of the safety concerns, if any, associated with its use. It is the responsibility of the user of this standard to become familiar with all hazards including those identified in the appropriate Material Safety Data Sheet for this product/material as provided by the manufacturer, to establish appropriate safety and health practices, and determine the applicability of regulatory limitations prior to use.*

## 2. Referenced Documents

### 2.1 ASTM Standards:

- B 775 Specification for General Requirements for Nickel and Nickel Alloy Welded Pipe
- B 899 Terminology Relating to Non-ferrous Metals and Alloys

## 3. Terminology

**3.1** Terms defined in Terminology B 899 shall apply unless otherwise defined in this standard.

## 4. General Requirement

**4.1** Material furnished in accordance with this specification shall conform to the applicable requirements of the current edition of Specification B 775 unless otherwise provided herein.

## 5. Classification

**5.1 Class 1** — Welded, cold worked, solution treated, and each piece of each lot subjected to one of the following four tests: hydrostatic, pneumatic (air underwater), eddy current, or ultrasonic.

**5.2 Class 2** — Welded, cold worked, solution treated, and each piece of each lot leak tested (hydrostatic or pneumatic) plus electric tested (eddy current or ultrasonic).

## 6. Ordering Information

**6.1** It is the responsibility of the purchaser to specify all requirements that are necessary for material ordered under this specification. Examples of such requirements include, but are not limited to, the following:

- 6.1.1** Alloy name or UNS number,
- 6.1.2** ASTM designation and year of issue,
- 6.1.3** Dimensions:
  - 6.1.3.1** Pipe size,
  - 6.1.3.2** Length (specific or random),
- 6.1.4** Class (see Section 5),
- 6.1.5** Quantity (feet or number of pieces),
- 6.1.6** *Certification* — Certification is required,
- 6.1.7** *Samples for Product (Check) Analysis* — State whether samples for product (check) analysis should be furnished, and

**6.1.8** *Purchaser Inspection* — If the purchaser wishes to witness tests or inspection of material at the place of manufacture, the purchase order must so state indicating which tests or inspections are to be witnessed.

## 7. Material and Manufacture

**7.1** Pipe shall be made from flat-rolled alloy by an automatic welding process with no addition of filler metal. Subsequent to welding and prior to final solution treatment,

Class 1 and Class 2 material shall be cold worked either in both weld and base metal or in weld metal only.

NOTE 1 — The recommended heat treatment shall consist of heating to a minimum temperature of 2025°F (1105°C) for UNS N08367 and quenching in water or rapidly cooling by other means.

**7.2** Pipe shall be furnished with oxide removed. When solution treatment is performed in a protective atmosphere, descaling is not necessary.

## 8. Chemical Composition

**8.1** The material shall conform to the requirements as to chemical composition prescribed in Table 1. One test is required for each lot as defined in Specification B 775.

**8.2** If a product (check) analysis is performed by the purchaser, the material shall conform to the product (check) analysis variations specified in Specification B 775.

## 9. Mechanical Properties and Other Requirements

**9.1 Mechanical Properties** — The material shall conform to the mechanical properties prescribed in Table 2. One test is required for each lot as defined in Specification B 775.

### 9.2 Flattening Test Requirements:

**9.2.1** Flattening test specimens shall show no cracks or breaks on the inside, outside, or end surfaces during the first step of the test.

**9.2.2** Evidence of laminated or unsound material or of incomplete weld that is revealed during the entire flattening test shall be cause for rejection.

**9.2.3** Surface imperfections not evident in the test specimens before flattening, but revealed during the first step of the flattening test, shall be judged in accordance with the finish requirements.

**9.2.4** Superficial ruptures resulting from surface imperfections shall not be cause for rejection.

TABLE 1  
CHEMICAL REQUIREMENTS

Element	Composition Limits, %, N08367
Carbon	0.030 max
Manganese	2.00 max
Phosphorus	0.040 max
Sulfur	0.030 max
Silicon	1.00 max
Chromium	20.00–22.00
Nickel	23.50–25.50
Molybdenum	6.00–7.00
Nitrogen	0.18–0.25
Iron <sup>4</sup>	balance
Copper	0.75 max

<sup>4</sup> Iron shall be determined arithmetically by difference.

TABLE 2  
MECHANICAL PROPERTIES

Type	Gage	Tensile Strength, min, ksi (MPa)	Yield Strength, (0.2% Offset), min, ksi (MPa)	Elongation in 2 in. or 50 mm (or 4D), min, %
N08367	≤ <sup>3</sup> / <sub>16</sub>	100 (690)	45 (310)	30
	> <sup>3</sup> / <sub>16</sub>	95 (655)	45 (310)	30

### 9.3 Nondestructive Test Requirements:

**9.3.1** Pipe shall be subjected to a pressure test or nondestructive electric test in accordance with Specification B 775.

## 10. Keywords

**10.1** UNS N08367; welded pipe